

OPERATION & MAINTENANCE MANUAL

CK1200G



APPLICABLE : From GK05-04001

BOOK CODE : S2GK04101ZE13

(C) Printed in Japan 2014.02

	TABLE OF CONTENTS	
	IMPORTANT INFORMATION	
1.	SAFETY	1
2.	OPERATION	2
3.	LOAD SAFETY DEVICE	3
4.	ASSEMBLY/DISASSEMBLY OF MAIN MACHINERY	4
5.	ASSEMBLY/DISASSEMBLY OF CRANE ATTACHMENT	5
6.	WIRE ROPE	6
7.	MAINTENANCE	7
8.	REFERENCE MATERIALS	8
9.	ELECTRIC SYSTEM SCHEMATIC	9

IMPORTANT INFORMATION

1. SAFETY

1.1	SAFETY INFORMATION	1-1
1.2	EXPLANATION OF WARNING LABELS IN THE MACHINE	1-2
1.2.1	HANDLING OF WARNING LABELS IN THE MACHINE	1-2
1.2.2	LABEL LAYOUT	1-3
1.3	SAFE OPERATING PRACTICES FOR MOBILE CRANES	1-20
1.4	SAFETY AT INSPECTION AND MAINTENANCE WORK	1-43
1.5	SAFETY DURING ASSEMBLY AND DISASSEMBLY WORK	1-46
1.6	CAUTIONS IN HANDLING OIL AND PAINT	1-47
1.7	SAFETY EQUIPMENT (OPTION)	1-48

2. OPERATION

2.1	TERMINOLOGY OF MACHINE EACH PART	2-1
2.2	LOCATIONS AND TERMS OF OPERATING CONTROLS	2-3
2.2.1	HANDING LEVER AND PEDAL	2-4
2.2.2	OPERATING SWITCHES	2-11
2.2.3	VARIOUS SETTING OF MONITOR	2-39
2.2.4	WIND SPEED SENSOR INSTALLATION (OPTION)	2-49
2.2.5	AIR CONDITIONER	2-50
2.2.6	AM/FM RADIO	2-56
2.2.7	1WAY CALL (TRANSMITTER)	2-64
2.2.8	CAMERA MONITOR (OPTION)	2-65
2.3	CRANE OPERATION	2-68
2.3.1	ADJUSTING THE OPERATOR'S SEAT	2-68
2.3.2	GETTING ON OR OFF THE OPERATOR SEAT	2-70
2.3.3	STARTING AND STOPPING THE ENGINE	2-71
2.3.4	AUTO IDLE STOP FUNCTION	2-85
2.3.5	FUNCTION LOCK LEVER	2-88
2.3.6	PROPELLING OPERATION	2-89
2.3.7	SWINGING OPERATION	2-92
2.3.8	BOOM RAISING/LOWERING OPERATION	2-95
2.3.9	HOOK RAISING/LOWERING OPERATION	2-99
2.4	FREE FALL OPERATION (OPTION)	2-107
2.5	CLAMSHELL OPERATION	2-114
2.5.1	PREPARATION WORK	2-115
2.5.2	CLAMSHELL WORK	2-119
2.6	HANDLING OF HYDRAULIC TAGLINE (OPTION)	2-120
2.7	HANDLING OF VIBRO HAMMER	2-123
2.8	HANDLING OF REEVING WINCH (OPTION)	2-126

2.8.1	PREPARATION BEFORE HANDLING REEVING WINCH.....	2-127
2.8.2	HANDLING PROCEDURE OF REEVING WINCH.....	2-129
2.9	OPERATION IN WEATHER CHANGE AND SPECIAL CIRCUMSTANCE.....	2-134
2.9.1	CAUTION AGAINST WIND.....	2-134
2.9.2	CAUTION AGAINST ELECTRIC SHOCK.....	2-145
2.9.3	CAUTION AGAINST RADIO WAVE INTERFERENCE.....	2-147
2.9.4	CAUTION AGAINST LIGHTNING.....	2-148
2.9.5	COUNTERMEASURE AGAINST EARTHQUAKE.....	2-149

3. LOAD SAFETY DEVICE

3.1	ARRANGEMENT OF EQUIPMENTS.....	3-3
3.2	TYPES AND FUNCTIONS OF EQUIPMENT.....	3-7
3.3	CONNECTING PROCEDURE OF WIRING.....	3-14
3.3.1	CRANE ATTACHMENT.....	3-14
3.4	FUNCTION OF MONITOR.....	3-21
3.5	OPERATING PROCEDURE OF MONITOR.....	3-22
3.5.1	SETTING OF CRANE CONFIGURATION.....	3-27
3.5.2	SELECTION OF MAIN LIFTING / AUXILIARY LIFTING.....	3-35
3.5.3	SETTING OF WORK AREA LIMIT VALUE.....	3-36
3.6	SWING LIMITATION DEVICE (OPTION).....	3-41
3.7	FUNCTION OF GROUND INCLINE INDICATOR (OPTION).....	3-51
3.8	LOAD HISTORY (DATA LOGGER).....	3-52
3.9	ALARMING AND AUTO-STOP.....	3-53
3.9.1	CONTENT OF ALARM AND AUTO-STOP.....	3-53
3.9.2	CONTENT OF AUTO-STOP.....	3-54
3.9.3	RELEASING AUTO-STOP.....	3-56
3.10	INSPECTION.....	3-62
3.10.1	INSPECTION PROCEDURE WHEN RAISING THE BOOM AFTER THE ATTACHMENT ASSEMBLY WORK IS COMPLETED.....	3-62
3.10.2	INSPECTION AFTER ERECTING ATTACHMENT.....	3-64
3.11	CAUTIONS IN HANDLING LOAD SAFETY DEVICE.....	3-66
3.12	ERROR CODE AND MESSAGE.....	3-67
3.13	MESSAGE TABLE.....	3-78
3.14	CHECKING PROCEDURE OF LOAD SAFETY DEVICE.....	3-84

4. ASSEMBLY/DISASSEMBLY OF MAIN MACHINERY

4.1	SWING AND PROPEL STABILITY.....	4-1
4.2	ASSEMBLY OF MAIN MACHINERY.....	4-3
4.2.1	UNLOADING MAIN MACHINERY FROM TRAILER.....	4-7
4.2.2	CRAWLER INSTALLATION.....	4-24
4.2.3	CAB STEP EXTENSION.....	4-39

4.2.4	CARBODY WEIGHT INSTALLATION	4-40
4.2.5	ASSEMBLING THE COUNTERWEIGHTS (USING SELF REMOVAL DEVICE)	4-46
4.2.6	REMOVING THE HOOK BLOCK FROM THE BOOM BASE	4-49
4.2.7	SETTING THE COUNTERWEIGHT LINK	4-50
4.2.8	INSTALLATION OF COUNTERWEIGHTS TO MACHINE (USING SELF REMOVAL DEVICE)	4-51
4.3	DISASSEMBLY OF MAIN MACHINERY	4-61
4.3.1	REMOVE THE COUNTERWEIGHTS FROM THE MACHINE (USING SELF REMOVAL DEVICE)	4-63
4.3.2	INSTALLATION OF THE HOOK BLOCK TO THE BOOM BASE	4-69
4.3.3	DISASSEMBLY OF THE COUNTERWEIGHT (USING SELF REMOVAL DEVICE)	4-70
4.3.4	CARBODY WEIGHT REMOVAL	4-74
4.3.5	CRAWLER REMOVAL	4-78
4.3.6	MAIN MACHINERY LOADING ONTO TRAILER	4-93
4.3.7	STOWING CAB STEP	4-107
4.4	TRANSPORTATION	4-108
4.4.1	CAUTION WHEN TRANSPORTING THE BASE MACHINE	4-109
4.5	LIFTING OF WHOLE MAIN MACHINERY	4-110
4.5.1	UPPER STRUCTURE (WITH CARBODY) LIFTING PROCEDURES	4-111
4.5.2	LOADING/UNLOADING THE MACHINE FROM/ONTO A TRAILER	4-112
4.5.3	INSTALLATION OF CRAWLER	4-113
4.5.4	INSTALLATION OF GANTRY TO SWING FRAME	4-113
4.6	ASSEMBLY OF BOOM BASE	4-116
4.6.1	BOOM BASE INSTALLATION	4-117
4.6.2	BACKSTOP INSTALLATION	4-119
4.6.3	UPPER SPREADER INSTALLATION	4-120
4.6.4	REEVING BOOM HOIST WIRE ROPE	4-121
4.6.5	INSTALLATION OF BOOM HOIST WIRE ROPE TO THE DRUM	4-123
4.6.6	REEVING HOOK HOIST WIRE ROPE	4-124
4.7	DISASSEMBLY OF BOOM BASE	4-125
4.7.1	WINDING UP OF BOOM HOIST ROPE	4-125
4.7.2	UPPER SPREADER REMOVAL	4-127
4.7.3	BACKSTOP REMOVAL	4-128
4.7.4	REMOVAL OF BOOM BASE	4-130
4.8	EXTENDING/RETRACTING THE CRAWLERS	4-132
4.8.1	EXTENDING THE CRAWLER	4-132
4.8.2	RETRACTING THE CRAWLER	4-141

5. ASSEMBLY/DISASSEMBLY OF CRANE ATTACHMENT

5.1	ASSEMBLING THE ATTACHMENT	5-5
5.1.1	ARRANGEMENT OF BOOM/JIB/GUY LINE	5-6
5.1.2	INSTALLING THE BOOM TIP	5-13
5.1.3	INSTALLATION OF THE BASIC GUY LINE.....	5-14
5.1.4	CONNECTING THE BOOM INSERT	5-16
5.1.5	INSTALLING THE CABLE ROLLERS.....	5-27
5.1.6	CONNECTING THE BOOM GUY LINES.....	5-28
5.1.7	CAUTION FOR CANTILEVER	5-30
5.1.8	FRONT DRUM WIRE ROPE REEVING.....	5-31
5.1.9	ASSEMBLING THE JIB.....	5-36
5.1.10	REEVING OF REAR DRUM WIRE ROPE	5-40
5.1.11	INSTALLING THE AUXILIARY SHEAVE.....	5-43
5.1.12	REEVING THE REAR DRUM WIRE ROPE TO THE AUXILIARY SHEAVE.....	5-44
5.1.13	FUNCTION CHECK OF EACH LIMIT SWITCH.....	5-46
5.2	ERECTING THE ATTACHMENT	5-47
5.2.1	CONFIRMATION BEFORE ERECTING THE ATTACHMENT	5-47
5.2.2	ERECTING THE ATTACHMENT	5-48
5.3	LOWERING THE ATTACHMENT	5-51
5.3.1	LOWERING THE ATTACHMENT	5-52
5.4	DISASSEMBLING THE ATTACHMENT	5-53
5.4.1	TREATMENT OF OVERHOIST LIMIT SWITCH WIRING.....	5-53
5.4.2	WINDING UP THE FRONT/REAR DRUM WIRE ROPES.....	5-56
5.4.3	DISASSEMBLING THE JIB.....	5-58
5.4.4	REMOVING THE AUXILIARY SHEAVE.....	5-60
5.4.5	REMOVING THE BOOM GUY LINE	5-61
5.4.6	REMOVING THE CABLE ROLLER.....	5-63
5.4.7	DISASSEMBLING THE BOOM.....	5-64
5.5	CAUTION WHEN TRANSPORTING BOOM.....	5-67

6. WIRE ROPE

6.1	HANDLING OF WIRE ROPE.....	6-1
6.1.1	SPECIFICATION OF WIRE ROPE	6-2
6.1.2	WIRE ROPE LENGTH.....	6-6
6.1.3	CAUTIONS IN HANDLING WIRE ROPE.....	6-8
6.1.4	WINDING WIRE ROPE TO THE DRUM.....	6-9
6.1.5	WINDING PROCEDURE OF WIRE ROPE TO DRUM.....	6-10
6.1.6	CORRECTING METHOD OF ENTANGLED WIRE ROPE.....	6-13
6.1.7	ROPE SOCKET INSTALLATION.....	6-16
6.1.8	REPLACEMENT STANDARDS FOR WIRE ROPE.....	6-17

7. MAINTENANCE

7.1	INSPECTION INTERVAL.....	7-9
7.1.1	INSPECTION POINT.....	7-9
7.1.2	GREASING (WATER SUPPLY) POINT.....	7-12
7.2	INSPECTION.....	7-15
7.2.1	INSPECTION OF UPPER MACHINERY.....	7-15
7.2.2	INSPECTION OF LOWER MACHINERY.....	7-22
7.2.3	INSPECTION OF ATTACHMENT.....	7-24
7.2.4	INSPECTION METHOD OF EACH POINT.....	7-26
7.3	OIL/GREASE SUPPLY AND WATER SUPPLY.....	7-50
7.3.1	UPPER LUBRICATION (INCL. WATER SUPPLY).....	7-54
7.3.2	LOWER LUBRICATION.....	7-58
7.3.3	ATTACHMENT LUBRICATION.....	7-60
7.3.4	INSPECTION, GREASING (WATER SUPPLY) ON EACH POINT.....	7-62
7.4	CLEANING/WASHING/CHANGING FILTER ELEMENT AND STRAINER.....	7-82
7.5	BATTERY INSPECTION.....	7-101
7.6	LOCATION AND USE OF FUSE.....	7-106
7.7	OPERATION UNDER SEVERE CONDITIONS.....	7-108
7.8	HANDLING OF DIESEL PARTICULATE FILTER.....	7-112
7.9	MACHINE STORAGE.....	7-115
7.10	TIGHTENING TORQUE VALUES.....	7-116
7.11	PERIODICAL REPLACING SECURITY PARTS.....	7-120
7.12	ADJUSTMENT.....	7-123
7.12.1	ADJUSTMENT OF FRONT, REAR, THIRD DRUM LOCKS.....	7-123
7.12.2	ADJUSTMENT OF BOOM DRUM LOCK.....	7-124
7.12.3	CRAWLER SHOES ADJUSTMENT.....	7-126
7.13	CONSUMABLE PARTS LIST.....	7-127
7.14	MEASURES REQUIRED FOR FRONT, REAR WINCH MONITORING.....	7-133
7.14.1	THEORETICAL SERVICE LIFE.....	7-133
7.14.2	USED PROPORTION OF THEORETICAL SERVICE LIFE.....	7-134
7.14.3	EXAMPLE.....	7-139

8. REFERENCE MATERIALS

8.1	SPECIFICATION.....	8-1
8.1.1	OUTER DIMENSION.....	8-2
8.1.2	CRANE SPECIFICATION, PERFORMANCE.....	8-3
8.1.3	CRANE WORKING RANGES.....	8-4
8.2	DIMENSION, WEIGHT OF EACH COMPONENT.....	8-7
8.2.1	BASE MACHINE.....	8-7
8.2.2	COUNTERWEIGHT.....	8-9
8.2.3	ATTACHMENT.....	8-11

8.3	CLAMSHELL RATED LOADS (OPTION).....	8-14
8.4	SWING AND PROPEL STABILITY	8-17
8.5	PROPEL ALLOWABLE SLOPE ANGLE.....	8-19
8.5.1	CRANE ATTACHMENT INSTALLED : BOOM INSERT CONFIGURATION.....	8-19
8.6	LOW GANTRY POSITION	8-26
8.7	SAFETY DEVICE LIST (OPTION).....	8-27

9. ELECTRIC SYSTEM SCHEMATIC

IMPORTANT INFORMATION

Thank you for your purchasing KOBELCO crawler crane.

Full-hydraulically operated crawler crane is manufactured based on our many years of experience and expertise.

This manual describes the important information about the Model CK1200G.

Before operating the machine, be sure to thoroughly read this manual to use the machine safely and efficiently.

⚠ WARNING

Do not operate or maintain this machine until you read this manual and understand the instructions.

Improper operation or maintenance of this machine may cause accidents and could result in serious injury or loss of life.

Always keep this manual in the operators cab. If it is missing or damaged, place an order to a KOBELCO authorize distributor for a replacement.

If the machine is to be sold to others, hand over this manual together.

If you have any questions, please consult your KOBELCO authorize distributor.

This machine's specification is based on Mobile crane ASME B30.5.

As for class of utilization related to crane life, this crane is classified as [A1] of ISO 4301/2, FEM 1.001.

If there is any doubt if this crane conforms to the standard or regulation of your country, contact KOBELCO or your nearest KOBELCO authorized distributor.

MACHINE SERIAL NUMBER AND HOUR METER

When you order repair parts and when you need repair or service of the machine, always inform us the machine serial number stamped on the name plate and the total number of hours indicated on the hour meter which is located in the gauge.

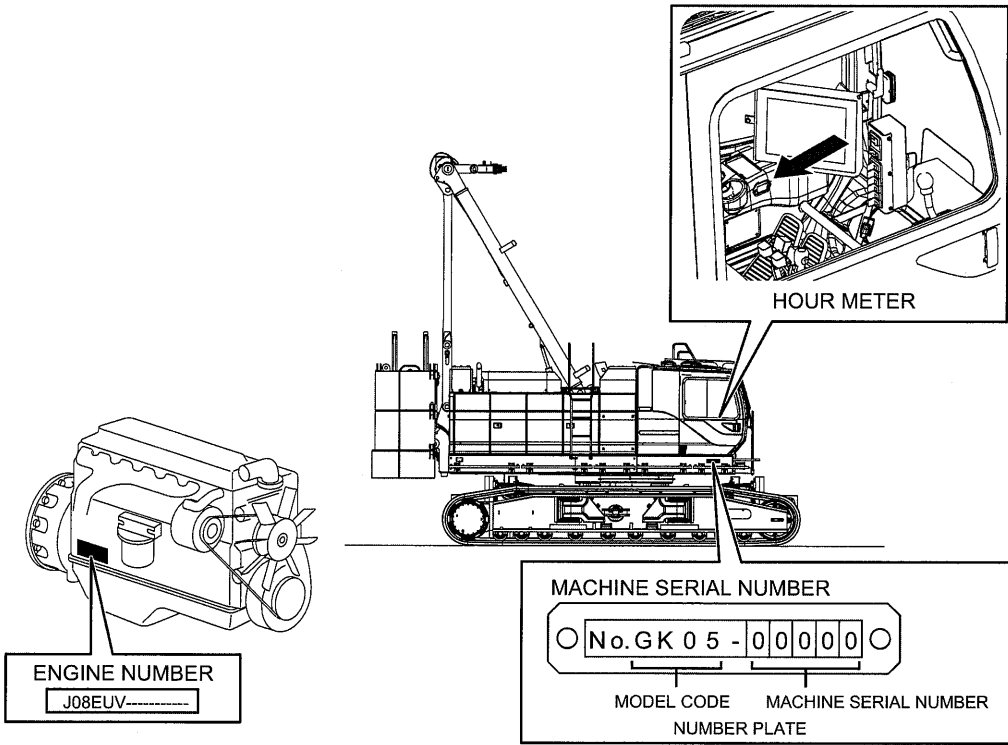

MACHINE MODEL	CK1200G	MACHINE SERIAL No.	GK05-	ENGINE No.	J08EUV-
---------------	---------	--------------------	-------	------------	---------

WARRANTY

The terms under which this machine is guaranteed are clearly defined in the accompanying WARRANTY. Trouble and damage occurred during the terms of guarantee shall be repaired at no cost to the purchaser according to the warrant description if the trouble or damage is recognized to be our responsibility. However, if you use the machine contrary to the instructions of this manual, the WARRANTY does not cover any damage to the machine.

REPAIR PARTS

When servicing and repairing the machine, be sure to use genuine parts in order to make the machine performance display sufficiently.

Since the important security parts are prepared to ensure safety and to protect the machine from an serious accident, be sure to replace them on every specified period of time.

MACHINE DIRECTION

FRONT, REAR, LEFT AND RIGHT

In this manual, idler wheel side is called "FRONT" of the lower machinery and "FRONT, REAR, LEFT AND RIGHT" of the upper machinery are called based on the operator's view when he sits down on the operator's seat and facing front.

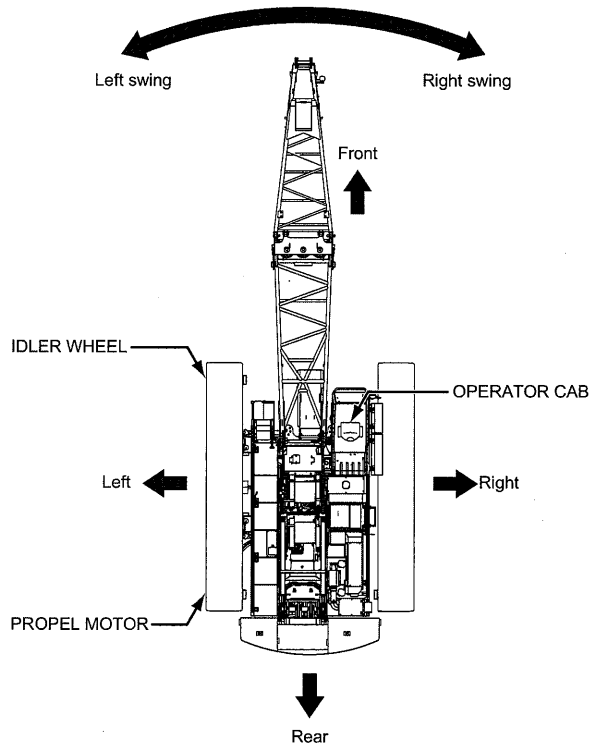

1. SAFETY

1.1	SAFETY INFORMATION	1-1
1.2	EXPLANATION OF WARNING LABELS IN THE MACHINE	1-2
1.2.1	HANDLING OF WARNING LABELS IN THE MACHINE.....	1-2
1.2.2	LABEL LAYOUT.....	1-3
1.3	SAFE OPERATING PRACTICES FOR MOBILE CRANES.....	1-20
1.4	SAFETY AT INSPECTION AND MAINTENANCE WORK	1-43
1.5	SAFETY DURING ASSEMBLY AND DISASSEMBLY WORK	1-46
1.6	CAUTIONS IN HANDLING OIL AND PAINT	1-47
1.7	SAFETY EQUIPMENT (OPTION).....	1-48

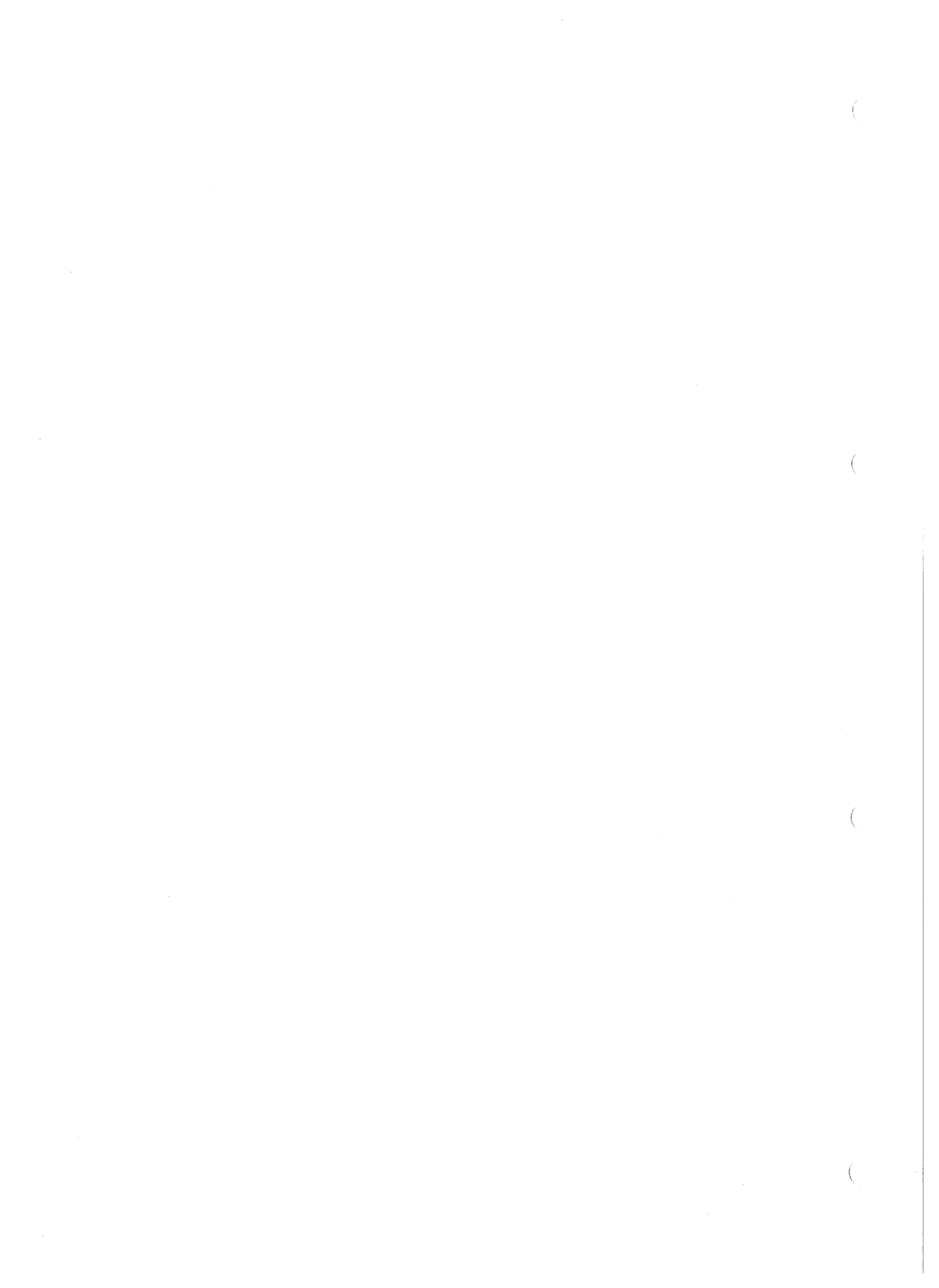

1. SAFETY

1.1 SAFETY INFORMATION

Most accidents, which occur during operation, are due to neglect of precautionary measures and safety rules. Sufficient care should be taken to avoid these accidents.

Erroneous operation, lubrication or maintenance services are very dangerous and may cause injury or death of personnel.

Thus, precautionary measures, or notes, written in this manual should be read and understood by personnel before starting each task.

Operation, inspection, and maintenance should be carefully carried out, and safety must be given the first priority.

Messages of safety are indicated with caution marks.

The safety information contained in this manual is intended only general safety information.

Messages of safety appear in this manual and on the machine.

All messages of safety are identified by the words "DANGER", "WARNING" and "CAUTION".

These words mean the following:



Indicates an imminently hazardous situation which, if not avoided, will result in a loss of life or serious injuries.



Indicates a potentially hazardous situation which, if not avoided, could result in a loss of life or serious injuries.



Indicates a potentially hazardous situation which, if not avoided, may result in a minor or moderate injuries.

It may also be used to alert against possible damage to the machine and its components.

Note

Supplementary explanation.

It is very difficult for us to forecast every danger that may occur during operation.

However, safety can be ensured by operating this machine according to methods recommended by KOBELCO.

While operating machine, be sure to perform work with great care, so as to not damage the machine, or let accidents occur.

Please continue studying this manual until proper operation is completely understood.

1.2 EXPLANATION OF WARNING LABELS IN THE MACHINE

Since the warning labels are installed in the machine and indicated with the three stages in the same way as the warning description, confirm the positions and contents of all warning labels first.

Put them to the practical use to secure safety when operating, checking and performing maintenance.

1.2.1 HANDLING OF WARNING LABELS IN THE MACHINE

1. When the warning label is damaged or stained, order it to the designated service shop.
2. Do not remove the warning labels.
3. When the surface of the warning label is soiled and difficult to be seen, wipe it cleanly.

1.2.2 LABEL LAYOUT

* Numbers in the drawings correspond with those in the label explanation detail after P.1-11.

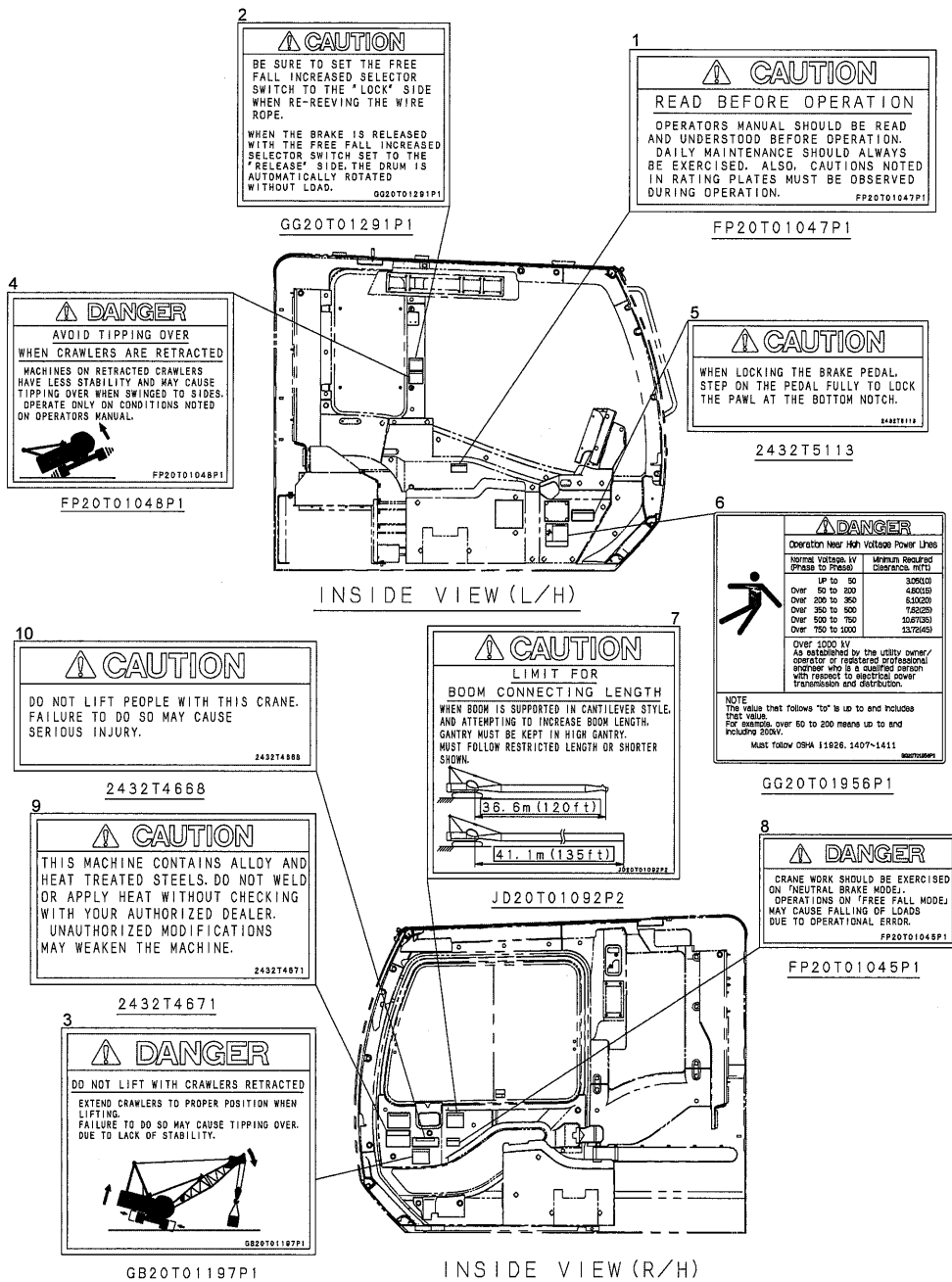

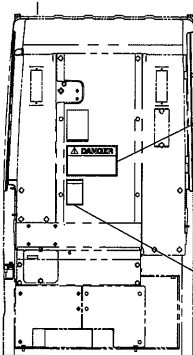

CAB INSIDE VIEW
(REAR)

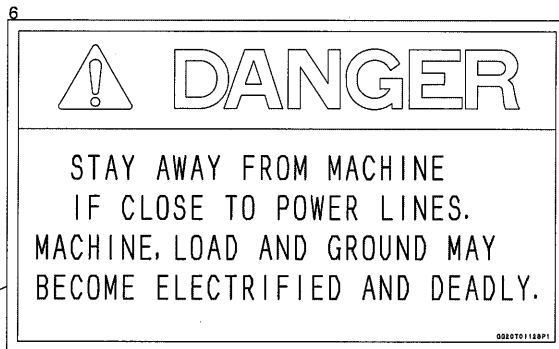

GG20T01128P1

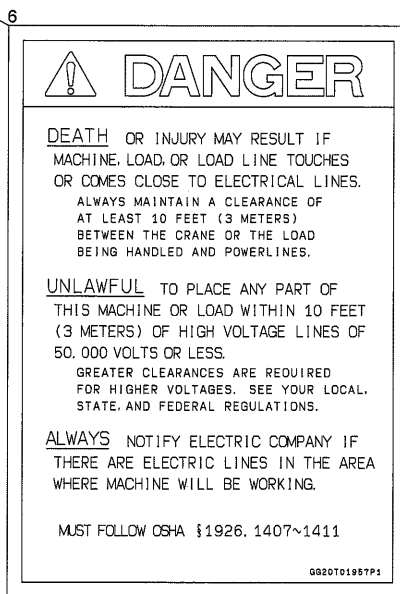

GG20T01957P1

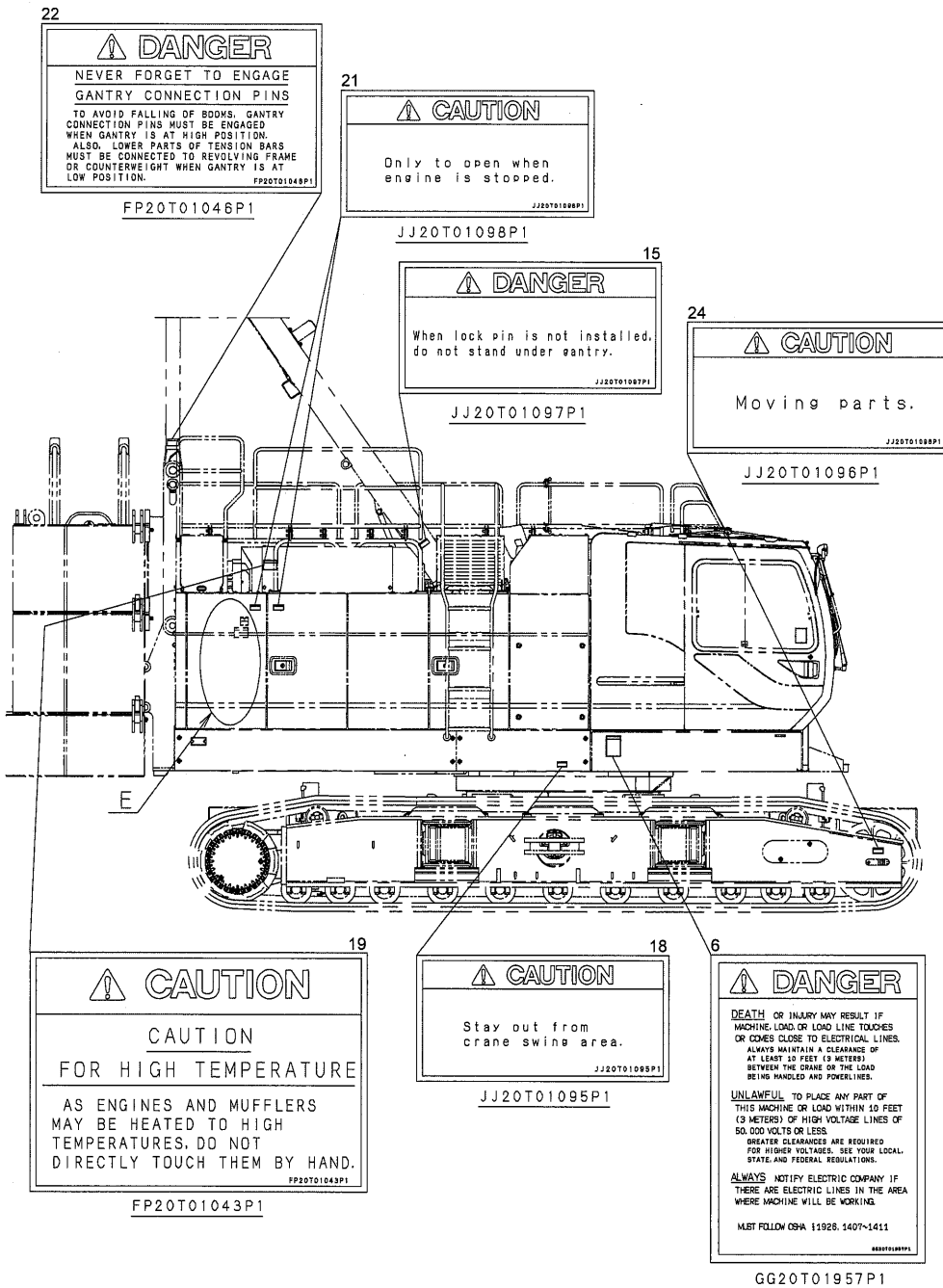

⚠ DANGER
 NEVER FORGET TO ENGAGE
 GANTRY CONNECTION PINS
 TO AVOID FALLING OF BOOMS, GANTRY
 CONNECTION PINS MUST BE ENGAGED
 WHEN GANTRY IS AT HIGH POSITION.
 ALSO, LOWER PARTS OF TENSION BARS
 MUST BE CONNECTED TO REVOLVING FRAME
 OR COUNTERWEIGHT WHEN GANTRY IS AT
 LOW POSITION.
 FP20T01046P1

FP20T01046P1

⚠ CAUTION
 Only to open when
 engine is stopped.
 JJ20T01098P1

JJ20T01098P1

⚠ DANGER
 When lock pin is not installed,
 do not stand under gantry.
 JJ20T01097P1

JJ20T01097P1

⚠ CAUTION
 Moving parts.
 JJ20T01096P1

JJ20T01096P1

⚠ CAUTION
 CAUTION
 FOR HIGH TEMPERATURE
 AS ENGINES AND MUFFLERS
 MAY BE HEATED TO HIGH
 TEMPERATURES, DO NOT
 DIRECTLY TOUCH THEM BY HAND.
 FP20T01043P1

FP20T01043P1

⚠ CAUTION
 Stay out from
 crane swing area.
 JJ20T01095P1

JJ20T01095P1

⚠ DANGER
 DEATH OR INJURY MAY RESULT IF
 MACHINE, LOAD OR LOAD LINE TOUCHES
 OR COMES CLOSE TO ELECTRICAL LINES.
 ALWAYS MAINTAIN A CLEARANCE OF
 AT LEAST 10 FEET (3 METERS)
 BETWEEN THE CRANE OR THE LOAD
 BEING HANDLED AND POWER LINES.
 UNLAWFUL TO PLACE ANY PART OF
 THIS MACHINE OR LOAD WITHIN 10 FEET
 (3 METERS) OF HIGH VOLTAGE LINES OF
 50,000 VOLTS OR LESS.
 GREATER CLEARANCES ARE REQUIRED
 FOR HIGHER VOLTAGES. SEE YOUR LOCAL,
 STATE, AND FEDERAL REGULATIONS.
 ALWAYS NOTIFY ELECTRIC COMPANY IF
 THERE ARE ELECTRICAL LINES IN THE AREA
 WHERE MACHINE WILL BE WORKING.
 MEET FOLLOW OSHA 11928, 1407-1411
 GG20T01957P1

GG20T01957P1

6

⚠ DANGER

STAY AWAY FROM MACHINE
IF CLOSE TO POWER LINES.
MACHINE, LOAD AND GROUND MAY
BECOME ELECTRIFIED AND DEADLY.

GG20T01128P1

22

⚠ DANGER

NEVER FORGET TO ENGAGE
GANTRY CONNECTION PINS

TO AVOID FALLING OF BOOMS, GANTRY
CONNECTION PINS MUST BE ENGAGED
WHEN GANTRY IS AT HIGH POSITION.
ALSO, LOWER PARTS OF TENSION BARS
MUST BE CONNECTED TO REVOLVING FRAME
OR COUNTERWEIGHT WHEN GANTRY IS AT
LOW POSITION.

FP20T01046P1

15

⚠ DANGER

When lock pin is not installed,
do not stand under gantry.

JJ20T01097P1

24

⚠ CAUTION

Moving parts.

JJ20T01096P1

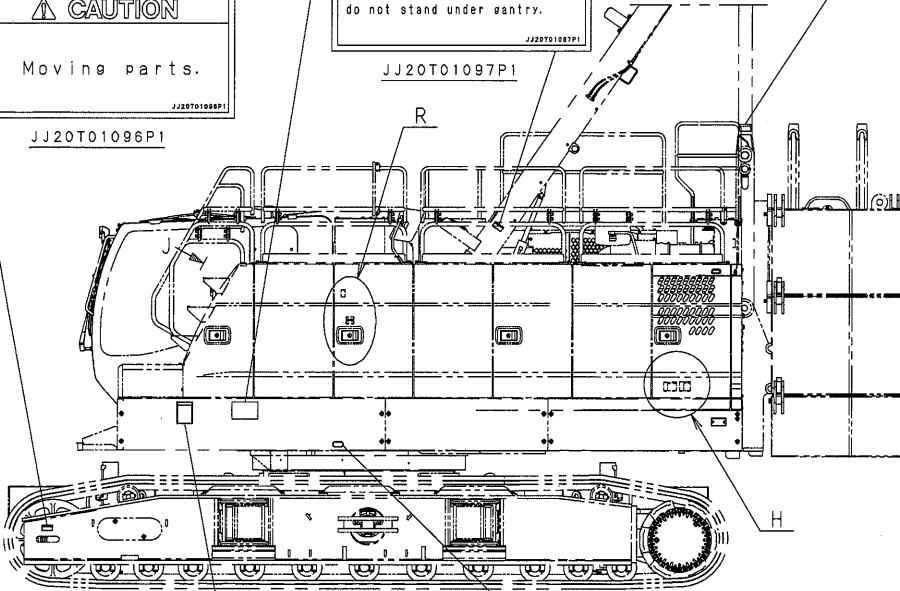

6

⚠ DANGER

DEATH OR INJURY MAY RESULT IF
MACHINE, LOAD, OR LOAD LINE TOUCHES
OR COMES CLOSE TO ELECTRICAL LINES.
ALWAYS MAINTAIN A CLEARANCE OF
AT LEAST 10 FEET (3 METERS)
BETWEEN THE CRANE OR THE LOAD
BEING HANDLED AND POWER LINES.

UNLAWFUL TO PLACE ANY PART OF
THIS MACHINE OR LOAD WITHIN 10 FEET
(3 METERS) OF HIGH VOLTAGE LINES OF
50,000 VOLTS OR LESS.
GREATER CLEARANCES ARE REQUIRED
FOR HIGHER VOLTAGES. SEE YOUR LOCAL
STATE, AND FEDERAL REGULATIONS.

ALWAYS NOTIFY ELECTRIC COMPANY IF
THERE ARE ELECTRIC LINES IN THE AREA
WHERE MACHINE WILL BE WORKING.

MUST FOLLOW OSHA 11926, 1407-1411

GG20T01957P1

18

⚠ CAUTION

Stay out from
crane swing area.

JJ20T01095P1

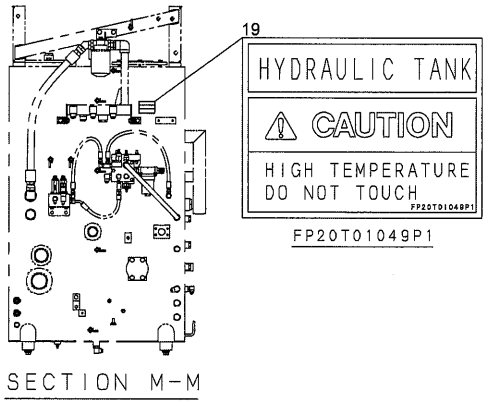
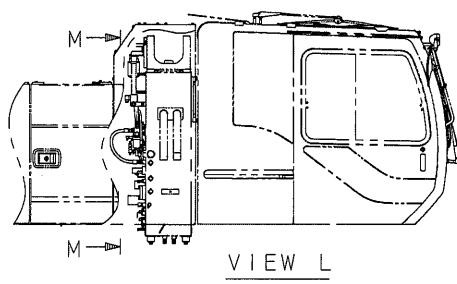
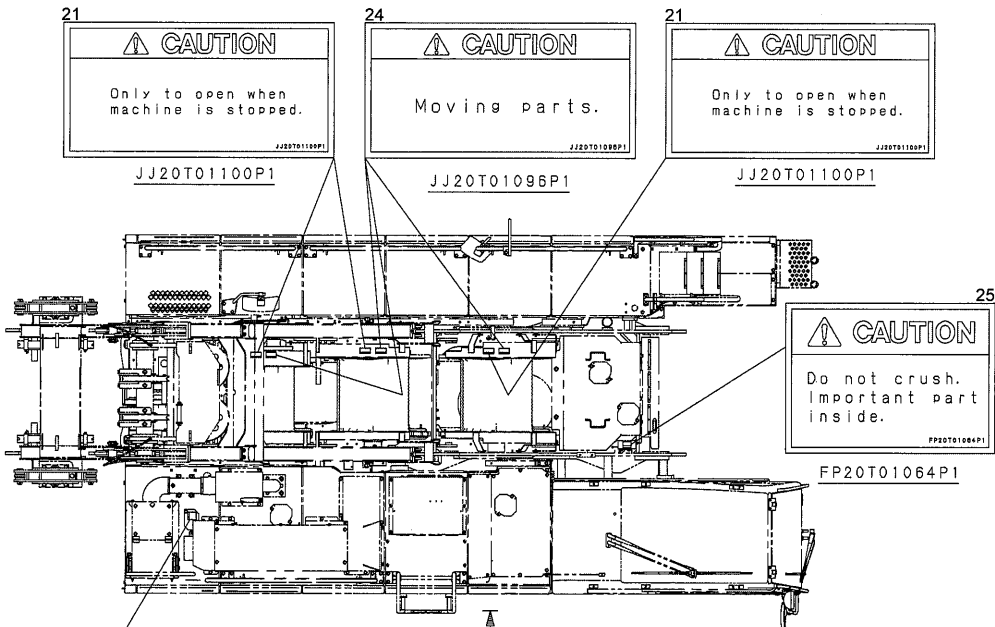

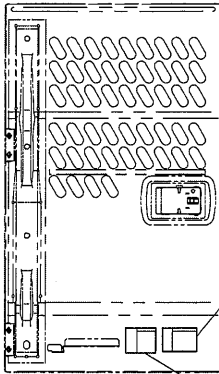

DETAIL H
(BATTERY)

11

	WARNING
	<p>PREVENT BATTERY EXPLOSION</p> <ul style="list-style-type: none"> Batteries give off hydrogen gases that can explode and cause personal injury. Keep sparks, open flames and cigarettes away from batteries. Keep metallic articles away from batteries. Keep all ventilation caps tightly secured. Never check charge by placing metal articles across battery terminals. Leave battery box open to improve ventilation when charging. <p>YN20T01001P1</p>

YN20T01001P1

11

	WARNING
	<p>AVOID ACID BURNS</p> <ul style="list-style-type: none"> Electrolyte is an acid and can cause injury or blindness if it contacts skin or eyes. Wear eye protection and protective clothing when handling or servicing batteries. If electrolyte contacts skin or eyes, flush affected areas immediately with clean water and seek medical attention immediately. <p>YN20T01017P1</p>

YN20T01017P1

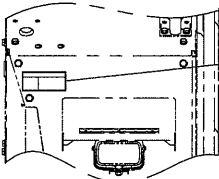

VIEW J

17

	WARNING
	<p>WALKING ON GUARDS MAY CAUSE STUMBLING AT PROJECTED ITEMS AND SLIPPING BY OIL, WATER, OR GREASE.</p> <p>PROTECTOR SHOULD BE EMPLOYED WHEN WALKING FOR MAINTENANCE JOBS, TO AVOID TIPPING OVER AND FALLING DOWN FROM THE MACHINE.</p> <p>FP20T01051P1</p>

FP20T01051P1

14

FUEL TANK
CAUTION
ULTRA LOW SULFUR FUEL ONLY
GG20T01809P1

GG20T01809P1

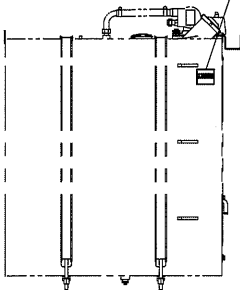

DETAIL R
(FUEL TANK)

23

	WARNING
	<p>Rotating parts can cause personal injury.</p> <p>Keep away from fan and belt when engine is running.</p> <p>Stop engine before servicing.</p> <p>YN20T01009P1</p>

YN20T01009P1

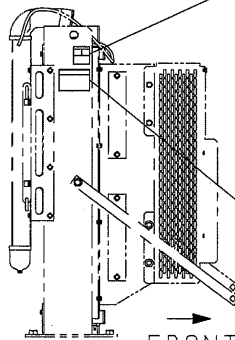

FRONT

DETAIL E
(RADIATOR)

19

CAUTION
CAUTION
FOR HIGH TEMPERATURE
AS ENGINES AND MUFFLERS MAY BE HEATED TO HIGH TEMPERATURES, DO NOT DIRECTLY TOUCH THEM BY HAND.
FP20T01043P1

FP20T01043P1

12

⚠ WARNING

AVOID EXPLOSION WHEN HANDLING ACCUMULATOR

THIS CASE IS CHARGED WITH HIGH PRESSURE NITROGEN GAS. NEVER ATTEMPT TO WELD, GAS-CUT, PUT ON FIRE, NOR DISASSEMBLE THE CASE TO AVOID EXPLOSION.

FP20T01042P1

FP20T01042P1

13

ACCUMULATOR

CHARGING GAS PRESSURE.

3.4~3.7 Mpa
(35 ~38 Kg/cm²)

GG20T01079P1

GG20T01079P1

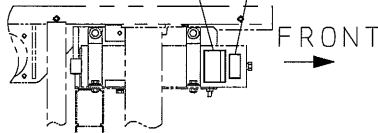

ACCUMULATOR

16

⚠ DANGER

Do not stand on or under the counterweight during counterweight is moved by installing or removing. Failure to observe this precaution may result in serious injury or the loss of life.

JJ20T01326P1

JJ20T01326P1

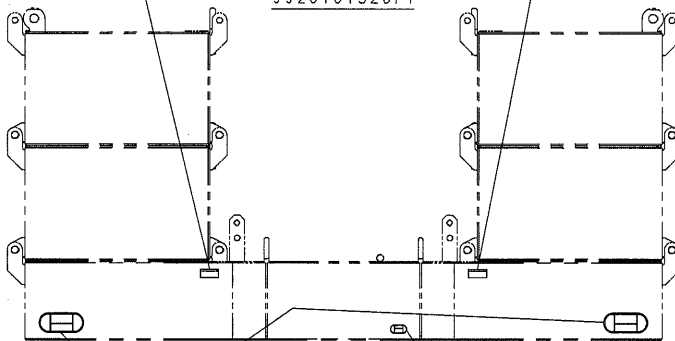

REAR VIEW

18

⚠ DANGER

KEEP CLEAR OF SWING AREA

YN20T01003P2

YN20T01003P2

18

⚠ DANGER

KEEP CLEAR OF SWING AREA

GG20T01557P1

GG20T01557P1

27

CAUTION

CAUTION FOR USING SPREADER GUIDES

TO AVOID DAMAGE TO SPREADER GUIDES, PLACE THE GUIDES TO STORING POSITION, AFTER SPREADER IS CONNECTED TO LOWER BOOM.

TO AVOID NIPPING OF HANDS OR FINGERS, AT FIRST THE GUIDES SHOULD BE HELD BY HANDS AND PINS DISENGAGED, AND THEN SHOULD BE PLACED IN STORING POSITION.

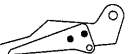
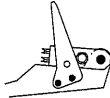
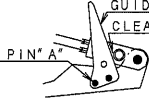
STORING POSITION WORKING POSITION DISASSEMBLING OF PIN "A"
(BOOM DISASSEMBLING / ASSEMBLING)

FP20T01012P1

FP20T01012P1

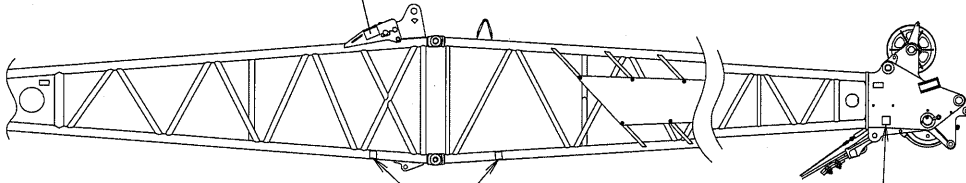

26

DANGER

DO NOT ENTER UNDER BOOM

TO AVOID SERIOUS INJURY CAUSED BY FALLING OF BOOM, DO NOT ENTER UNDER BOOM WHILE DISASSEMBLING/ASSEMBLING OF BOOM.





FP20T01013P1

FP20T01013P1

28

CAUTION

CORRECT WRONG

GG20T01561P1

Install the rope socket in the correct direction. Otherwise, the rope socket or the wire rope may interfere with the boom, causing damage to the boom or cut of the wire rope.

GG20T01561P1

26

DANGER

DO NOT ENTER UNDER BOOM

TO AVOID SERIOUS INJURY CAUSED BY FALLING OF BOOM, DO NOT ENTER UNDER BOOM WHILE DISASSEMBLING/ASSEMBLING OF BOOM.



FP20T01013P1

FP20T01013P1

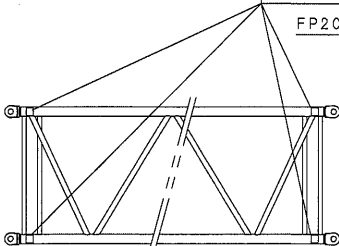

BOOM INSERT

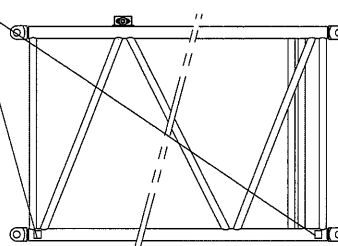

BOOM INSERT

1. Ensure to read the operators manual before operation / handling / assembly / disassembly / transportation / inspection / maintenance of the machine.

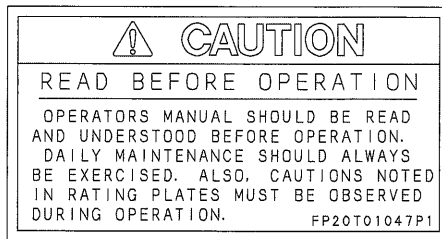

FP20T01047P1

2. If the free fall speed select switch is in speed increase side and the brake is released and the drum may rotate automatically to lowering side even without lifting load and wire rope may be paid out to lower the hook and rough spooling may be caused.
 When paying out the wire rope from the drum, ensure to set the free fall select switch to normal side.

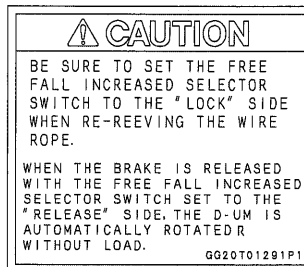

GG20T01291P1

3. The crane may turn over during work based on machine condition.
 Install the proper amount of the counterweight and secure them to make proper machine configuration.

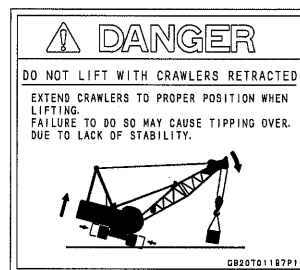

GB20T01197P1

4. If machine swings or is assembled / disassembled with crawler retracted, main machinery may turn over to rear side.
 Read the operator's manual carefully and set the crane to the proper configuration.

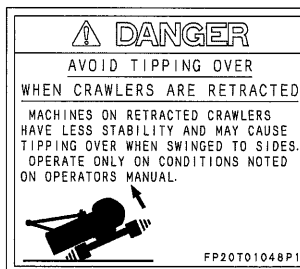

FP20T01048P1

5. If the brake pedal lock is not completely engaged, lifting load or hook may be lowered unexpectedly and is very dangerous.
 When locking the brake pedal, press the brake pedal fully and confirm that the pedal is locked completely.

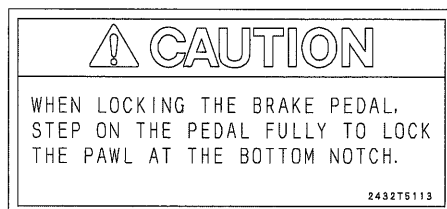

2432T5113

6. During crane work if the boom comes too close to the tower or power lines, electric shock may hit the crane.

Keep the boom away from the tower or power lines for safety.

 **DANGER**

STAY AWAY FROM MACHINE
IF CLOSE TO POWER LINES.
MACHINE, LOAD AND GROUND MAY
BECOME ELECTRIFIED AND DEADLY.

GG20T01128P1

GG20T01128P1



DANGER

Operation Near High Voltage Power Lines

Normal Voltage, kV (Phase to Phase)	Minimum Required Clearance, m(ft)
UP to 50	3.05(10)
Over 50 to 200	4.60(15)
Over 200 to 350	6.10(20)
Over 350 to 500	7.62(25)
Over 500 to 750	10.67(35)
Over 750 to 1000	13.72(45)

Over 1000 kV
As established by the utility owner/
operator or registered professional
engineer who is a qualified person
with respect to electrical power
transmission and distribution.

NOTE
The value that follows "to" is up to and includes
that value.
For example, over 50 to 200 means up to and
including 200kV.

Must follow OSHA §1926.1407~1411

GG20T01956P1

GG20T01956P1

 **DANGER**

DEATH OR INJURY MAY RESULT IF
MACHINE, LOAD, OR LOAD LINE TOUCHES
OR COMES CLOSE TO ELECTRICAL LINES.
ALWAYS MAINTAIN A CLEARANCE OF
AT LEAST 10 FEET (3 METERS)
BETWEEN THE CRANE OR THE LOAD
BEING HANDLED AND POWERLINES.

UNLAWFUL TO PLACE ANY PART OF
THIS MACHINE OR LOAD WITHIN 10 FEET
(3 METERS) OF HIGH VOLTAGE LINES OF
50,000 VOLTS OR LESS.
GREATER CLEARANCES ARE REQUIRED
FOR HIGHER VOLTAGES. SEE YOUR LOCAL,
STATE, AND FEDERAL REGULATIONS.

ALWAYS NOTIFY ELECTRIC COMPANY IF
THERE ARE ELECTRIC LINES IN THE AREA
WHERE MACHINE WILL BE WORKING.

MUST FOLLOW OSHA §1926.1407~1411

GG20T01957P1

GG20T01957P1

- 7. When the boom is assembled, disassembled, boom self erection / self lowering or crane work with the low gantry, the gantry or boom may be damaged and may fall off.
Raise the gantry to the proper position for work.

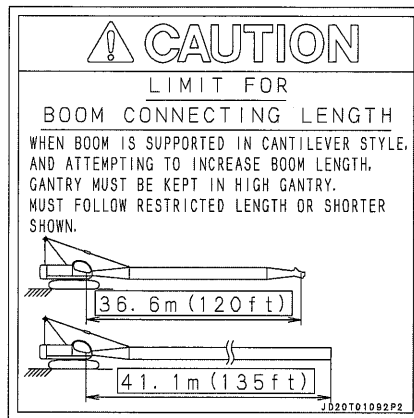

JD20T01092P2

- 8. Free fall work of load may cause dropping the load by mishandling.
Use power lowering of load in the crane work. (Even on neutral free side, power lowering is possible by turning the lever to lowering side.)

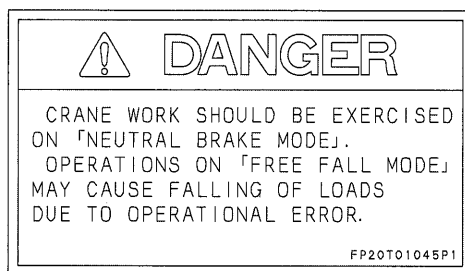

FP20T01045P1

- 9. This machine contains alloy and heat treated steels.
Do not weld or apply heat without checking with your authorized dealer.
Unauthorized modifications may weaken the machine.

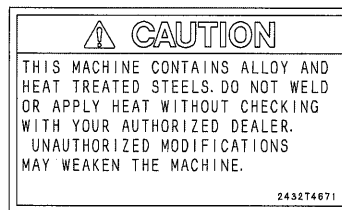

2432T4671

- 10. Do not lift people with this crane.
Failure to do so may cause serious injury.

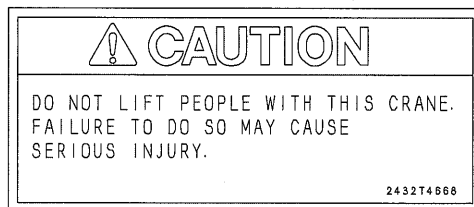

2432T4668

11. Wrong handling of battery may cause burns, blindness or explosion by inflammation.

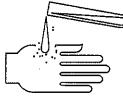
	⚠ WARNING
	<p>AVOID ACID BURNS</p> <ul style="list-style-type: none"> · Electrolyte is an acid and can cause injury or blindness if it contacts skin or eyes. · Wear eye protection and protective clothing when handling or servicing batteries. · If electrolyte contacts skin or eyes, flush affected areas immediately with clean water and seek medical attention immediately. <p style="text-align: right; font-size: small;">YN20T01017P1</p>

YN20T01017P1

	⚠ WARNING
	<p>PREVENT BATTERY EXPLOSION</p> <ul style="list-style-type: none"> · Batteries give off hydrogen gases that can explode and cause personal injury. · Keep sparks, open flames and cigarettes away from batteries. · Keep metallic articles away from batteries. · Keep all ventilation caps tightly secured. · Never check charge by placing metal articles across battery terminals. · Leave battery box open to improve ventilation when charging. <p style="text-align: right; font-size: small;">YN20T01001P1</p>

YN20T01001P1

12. If accumulator is handled in wrong way, burns, loss of eyesight, explosion may be caused.
 Take extra care in handling accumulator.
 (Do not weld, flame cut, dispose or disassemble.)

⚠ WARNING
<p>AVOID EXPLOSION WHEN HANDLING ACCUMULATOR</p> <p>THIS CASE IS CHARGED WITH HIGH PRESSURE NITROGEN GAS. NEVER ATTEMPT TO WELD, GAS-CUT, PUT ON FIRE, NOR DISASSEMBLE THE CASE TO AVOID EXPLOSION.</p> <p style="text-align: right; font-size: x-small;">FP20T01042P1</p>

FP20T01042P1

13. The accumulator is charged with high pressure nitrogen gas.
 Charge the nitrogen gas within the specified pressure.

<p>ACCUMULATOR</p> <p>CHARGING GAS PRESSURE.</p> <hr/> <p>3.4 ~ 3.7 Mpa (35 ~ 38 Kg/cm²)</p> <p style="text-align: right; font-size: x-small;">GG20T01079P1</p>

GG20T01079P1

14. Using the fuel other than the specified diesel fuel may cause engine failure, fire or explosion. Ensure to use the diesel fuel in the fuel tank. Use ultra low sulfur diesel fuel only. (S50 : sulfur content lower than 50 ppm)

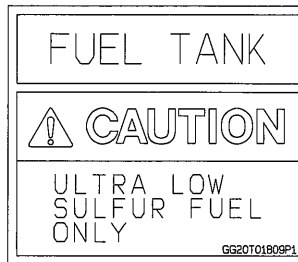

GG20T01809P1

15. After raising the gantry, ensure to insert the gantry fixing pin. Otherwise the gantry may come off and the boom may drop off.

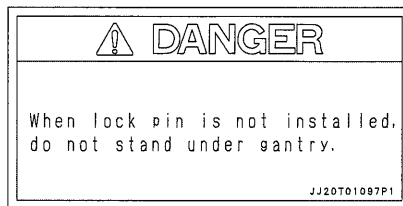

JJ20T01097P1

16. Handling the counterweight in wrong way is very dangerous. Never allow any person to enter under the lifting counterweight.

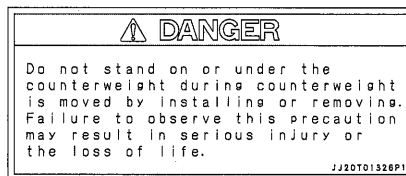

JJ20T01326P1

17. When working on the upper surface of the guard, person may fall off the upper surface of the guard. During high place work on the upper surface of the guard, do not come close to the guard side face to prevent falling off. During work on the upper surface of the guard, ensure to wear safety belt and hook the safety belt on the upper machinery and firmly stand on the guard.



FP20T01051P1

18. While the upper machinery is swinging, person may be crushed with the upper machinery. Never allow anybody to enter the swing range.

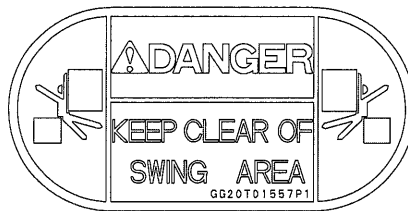

GG20T01557P1



YN20T01003P2

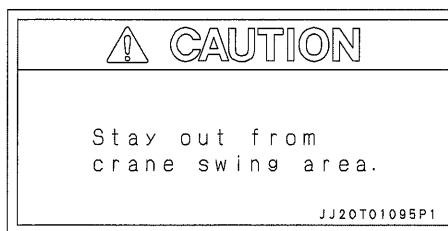

JJ20T01095P1

19. During engine running or straight after the engine is stopped, hydraulic oil tank, engine and muffler are hot.

Touching them may cause burns.

Do not touch the hot area.

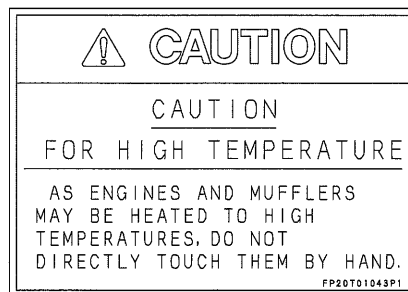

FP20T01043P1

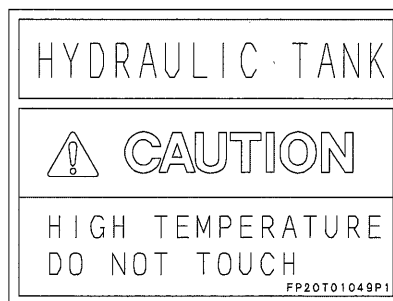

FP20T01049P1

20. During engine running or right after the engine is stopped, inside of the radiator becomes high pressure and hot.
 Person may get burns by hot water blow out when taking off the radiator cap.
 Take extra care of opening or closing of the radiator cap.

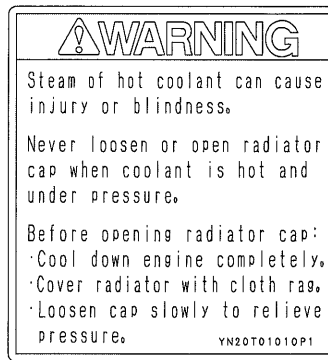

YN20T01010P1

21. When inspection or work is done by removing the drum flange cover, serious injuries may be caused if the drum rotates unexpectedly.
 Stop the crane and then remove the drum cover.

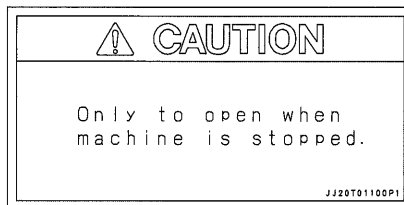

JJ20T01100P1

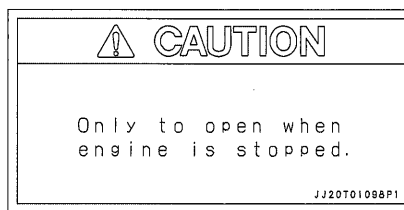

JJ20T01098P1

22. When the machine is transported with the low gantry, connect the tension bar to the revolving frame or counterweight.

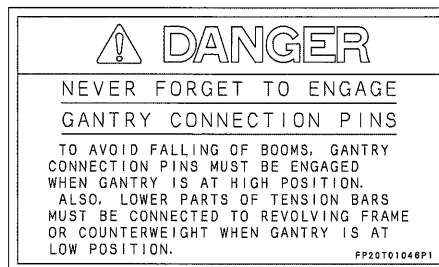

FP20T01046P1

23. When working on the engine area for inspection and maintenance, person may be entangled with the fan belt and may get injured if the engine is running.
Stop the engine when inspection or maintenance work is done.

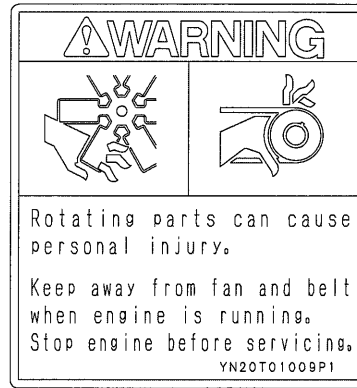

YN20T01009P1

24. There are some moving parts nearby.

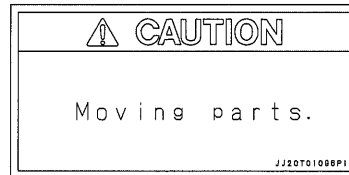

JJ20T01088P1

25. This is a connector cover of electrical wiring of safety device.
Do not step on and crush.

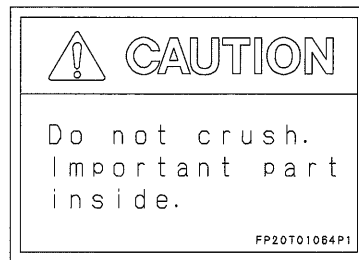

FP20T01064P1

26. Taking wrong procedure in boom assembly or disassembly may cause boom falling off and person may get injured.
Do not allow any person to enter the inside or under the boom during assembly or disassembly.

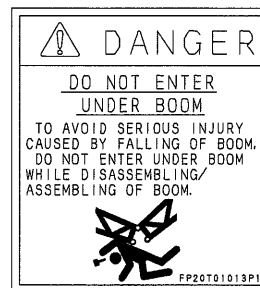

FP20T01013P1

27. Taking wrong method in using the spreader guide installed on the boom base may damage the spreader guide.

Set the spreader guide to the stowed position except when the upper spreader is connected is connected to the boom base.

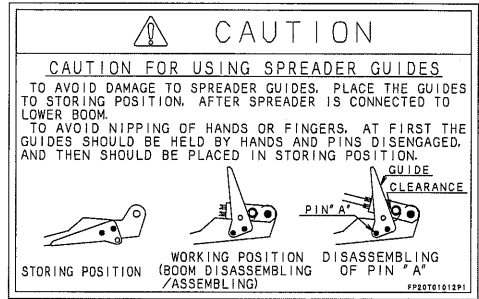

FP20T01012P1

28. Taking the wrong installing direction when the rope sockets are installed to the boom tip and jib tip, may damage the boom or may break the wire rope.

Install the rope socket in the proper direction.

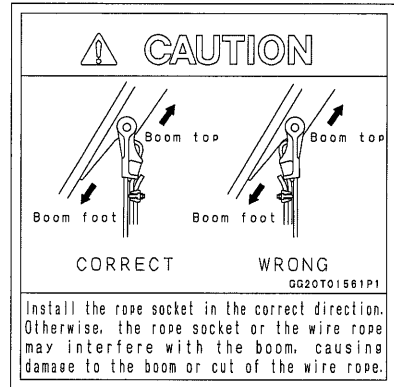

GG20T01561P1

CAUTION LABEL

- Keep the caution label in good condition to read.
- Whenever they become dirty, wash them with water or detergent.
- Whenever they are damaged or missed, replace them with the new and same ones.

1.3 SAFE OPERATING PRACTICES FOR MOBILE CRANES

INTRODUCTION

Because cranes have the ability to lift heavy loads to great heights, they also have a potential for accidents if safe operating practices are not followed.

This book will help you prevent accidents that could result in a injury, death, or property damage.

General safe practices for working on machinery must be followed as well as the safe operating practices recommended here.

OPERATOR'S RESPONSIBILITY

The operator is the best safety feature in any crane. Safety must always be the operator's most important concern.

He must refuse to operate when he knows it is unsafe and consult his supervisor when safety is in doubt.

He must read and understand the Operator's Manual and see that the machine is in proper order before operating.

He must understand how to read the rating plate and know that his machine can safely lift each load before attempting to lift it.

He must never lift a load without knowing the length of the boom, the weight of the load, and the load radius or boom angle.

Never attempt to operate the crane at conditions exceeding those shown on the rating chart.

Such operation can cause tipping or structural failure of the crane that can result in a damage, injury, or loss of life.

He must be alert, physically fit, and free from the influences of alcohol, drugs, or medications that might affect his eyesight, hearing, reactions, judgment.

He must see that unnecessary people, equipment, and material are kept out of the work area.

The area around the machine should be properly barricaded.

When an operator's vision is restricted or when operating in hazardous places such as near electrical power lines or around people, a signalman must be used.

Because the operator is not always in the best position to judge distances and can not see all parts of the job site, a signalman may also be necessary at other times.

Operators must understand standard crane signals and take signals only from designated signalmen.

SIGNALMAN'S RESPONSIBILITY

The primary duty of a signalman is to assist the operator in safe and efficient operation.

Operators depend on designated signalmen to assist them in making movements without endangering people or property.

Signalmen must have a clear understanding of the work to be done so that they can safely coordinate each job with operators and other crew members.

Signalmen must place themselves where they can be clearly seen and where they can safely observe the entire operation.

Standard crane signals must be used unless other methods of signaling, such as two way radios or flags have been agreed upon.

CREW MEMBER'S RESPONSIBILITY

Any unsafe condition or practice must be corrected or reported to the job supervisor.

Everyone who works around the crane, including riggers and oilers, must obey all warning signs and watch out for his own safety and the safety of others.

Crew members setting up machines or handling loads are expected to know proper machine erection and rigging procedures.

Watch for hazards during operations and alert the operator and signalmen of dangers such as power lines, the unexpected presence of people, other equipment or unstable ground conditions.

MANAGEMENT'S RESPONSIBILITY

See that operators are trained, competent, physically fit and, if required, licensed.

Good vision is required, as are good judgment, coordination and mental ability.

Any person who lacks any of these qualities must not be allowed to operate a crane.

Signalmen must have good vision and sound judgment, know standard crane signals and be able to give signals clearly.

They must have enough experience to be able to recognize hazards and signal the operator to avoid them.

Riggers must be trained to determine weights and distances and to select proper lifting tackle.

Rigging is a complex subject far beyond the scope of this manual.

It is management's responsibility to employ qualified riggers.

Crew members must be given specific safety responsibilities and instructed to report any unsafe conditions to their supervisors.

PLANNING THE JOB

Most accidents can be avoided by careful job planning. The person in charge must have a clear understanding of the work to be done and equipment capabilities.

He must consider all dangers at the job site, develop a plan to do the job safely, and then explain the plan to all concerned.

Factors such as these should be considered :

- What crew members are needed and what responsibilities will they be given?
- What is the weight of the load to be lifted, the lift radius, boom angle, and the rated capacity of the crane?
- How will the signalmen communicate with the operator?
- What equipment is required to do the job safely?
Is a crane the best equipment for the job?
- How can the equipment be safely transported to the job site?
- Are there gas lines, electrical power lines or structures that must be moved or avoided?
- Is the surface strong enough to support the machine and load?
- How will loads be rigged?
- What special safety precautions must be taken if a crane must travel with a suspended load or if more than one crane is needed to lift a load?
- Are unusual weather conditions such as winds or extreme cold expected?
- What steps will be taken to keep unnecessary people and equipment safely away from the work area?
- How can the crane be positioned to use the shortest boom and radius possible?
- Is "OFF LIMIT" sign posted in the swing radius area?

OPERATOR'S CHECK LIST

The operator must make a safety check before starting to work each day to see that the machine is in proper order.

Some things to check are :

- Check the machine log book to see that periodic maintenance and inspections have been performed and all necessary repairs made.
- Check the operation of the boom hoist kickout, boom angle indicator, back up alarms, and other safety devices.
- Carefully inspect load bearing parts such as wire rope, (load lines, boom hoist cable, suspension lines), boom, outriggers, hooks, and rigging.
- Inspect the crane for any missing bolts, nuts or pins and any cracked or broken components.
- Be sure no unauthorized field modifications have been made, such as counterweights increased or decreased and booms that have been improperly repaired.
- Check for fuel and hydraulic oil leaks.
- After starting the engine, check all gauges for proper readings.
- Test all controls for proper operation.
- Check brakes and clutches.
Test load brakes by lifting a load a few inches off the ground and holding it.

OPERATING PRECAUTIONS

The following recommendations represent our experience in regard to the most likely causes of personal injuries and damage to equipment. Careful observance of the following recommendations will prevent the majority of common accidents.

1. Mistakes in calculating lifting capacity can cause accidents.

Several factors must be considered including :

- (1) Load radius (the distance between the center of the crane rotation to the center of the load). Note that the radius will increase when the load is lifted.
- (2) Weight of the load, hook, and rigging.
- (3) Boom length, jib, parts of line, and operating area (side, rear).

Use the next lower rated capacity when working at boom length or radii between the figures on the rating chart.

It is dangerous to guess the capacity for boom length or radii between those listed on the rating plate.

Trying to lift a load without knowing whether it is within the rated capacity while expecting the crane to start to tip to warn of an overload is very dangerous and should never be done. Cranes may suddenly tip over or collapse.

Always operate within the rated capacity.

The operator must reduce the load under adverse field conditions until, in his judgment, the machine can safely handle the lift.

(See Operating Precautions #3, 10, 16, 19, 27, and 28.)

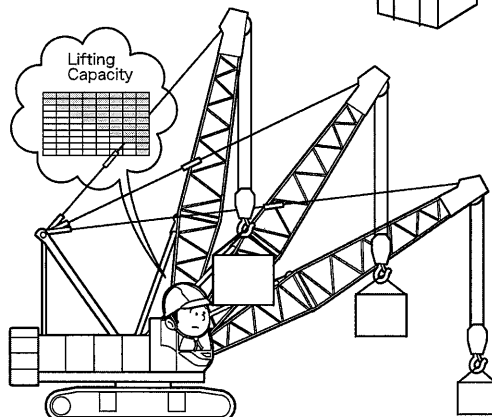
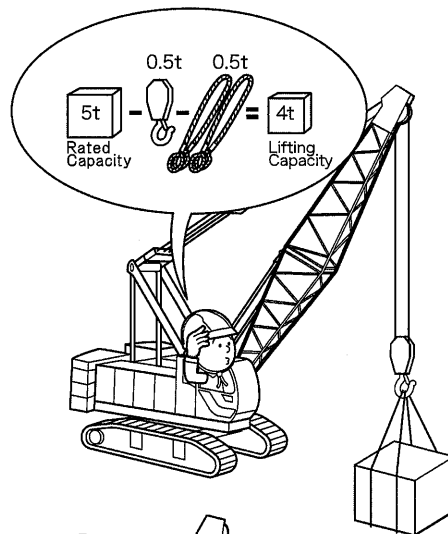
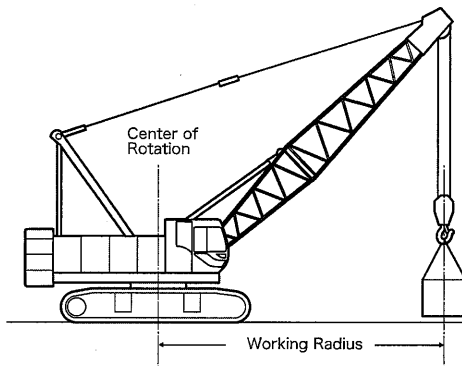

2. Cranes may tip over or collapse if the operating surface cannot support their weight.

Timber mats, steel plates or concrete rafts may be needed under crawlers to distribute the load under the crane so that the bearing strength of the ground is not exceeded.

Determine the load bearing capacity of the ground or other surface on which machines will be operating.

Be sure cranes are adequately supported.

Avoid soft or unstable ground, sand, areas with high water tables, and partially frozen ground.

When machines are working near trenches, the trenches should be shored or sloped to prevent cave-ins or slides.

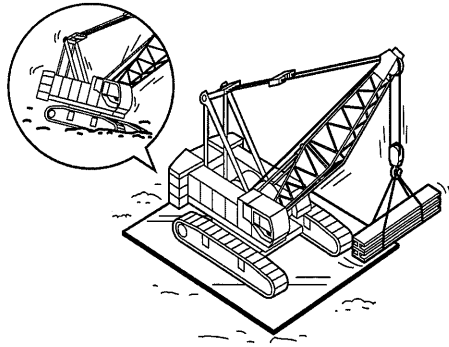

3. The rated capacity of a crane is determined with the crane leveled within ± 0.5 degrees of grade (1 foot drop or rise in 100 foot distance).

Out of level more than ± 0.5 degrees will drastically reduce the lifting capacity.

Be sure cranes are level.

4. People can be crushed by the scissors-like action of the upper rotating on the lower.

Stay away from rotating cranes.

Erect barricades to keep people away.

Take the time to determine that these areas are clear before swinging.

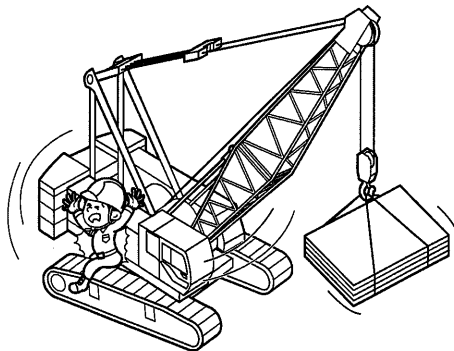

5. People can be crushed by the rear (counterweight) of the machine if there is not enough room for it to swing. Position machines so that people cannot be trapped between the counterweight and other obstructions.



6. Many people have been injured when riding crane hooks or loads. They have no control over how they are handled and no protection from impacts or falls. Small mistakes can be fatal.

Never permit anyone to ride loads, slings, hooks, etc., for any reason.

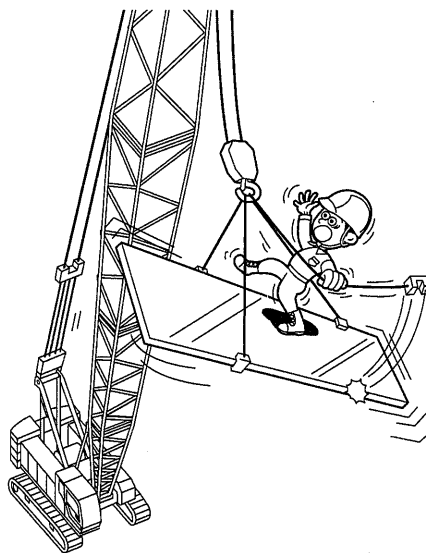

7. Power electrical lines have killed or serious injured people working around cranes and excavators.

These accidents can be avoided by following a few simple rules.

Always determine whether there are power lines in the area before starting any job, assembly and disassembly.

OSHA regulations require at least 3.05 meter (10 feet) of clearance from lines carrying 50,000 volts or less.

Greater clearances are required for lines with higher voltages.

Some states require greater clearances than OSHA.

Safety requires that you stay as far as possible from power lines and never violate minimum clearances.

Always take these precautions if power lines are present.

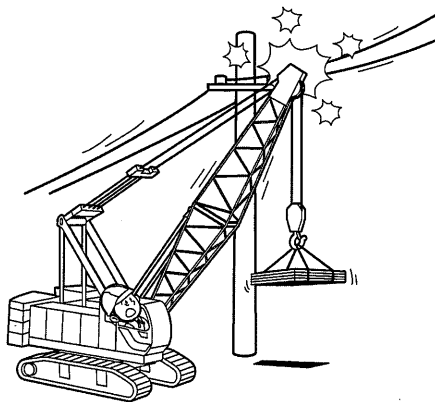

- (1) Hold a job site meeting and make all people concerned aware of work procedure.
- (2) For tagline work, ensure to use nonconductive type tagline rope.
- (3) Ensure to use swing angle limiter (if available).
- (4) Ensure to use visual signs such as an elevated warning line or barricade.
- (5) Ensure to use boom angle and work radius limiter.
- (6) Notify the electrical power company before beginning work.
- (7) You and the power company must take specific precautions.
 These may include locating cranes and materials away from electrical power lines, de-energizing and grounding lines, rerouting lines, removing barricading lines, and insulating lines with rubber sleeves.
- (8) Use a signalman to maintain a safe distance between any part of the machine or load and electrical power lines.
 The operator is not in the best position to judge distances.
- (9) Warn people to stay away from the machine and load at all times.
 If the load must be guided into place, ask the power company about special precautions such as insulated poles or hot sticks.
- (10) Slow down.
 Give yourself time to react to problems and to double check the distance between electrical power lines and any part of the machine or load.

Operation near high voltage power lines		
	Normal voltage, kV (Phase to Phase)	Minimum required clearance, m (ft)
	UP to 50	3.05 (10)
Over	50 to 200	4.60 (15)
Over	200 to 350	6.10 (20)
Over	350 to 500	7.62 (25)
Over	500 to 750	10.67 (35)
Over	750 to 1000	13.72 (45)
Over 1000 kV As established by the utility owner/operator or registered professional engineer who is a qualified person with respect to electrical power transmission and distribution.		
NOTE The value that follows "to" is up to and includes that value. For example, over 50 to 200 means up to and including 200 kV.		

Operation in transit with no load and boom or mast lowered.		
	Normal voltage, kV (Phase to Phase)	Minimum required clearance, m (ft)
Over	UP to 0.75	1.22 (4)
Over	0.75 to 50	1.83 (6)
Over	50 to 345	3.05 (10)
Over	345 to 750	4.87 (16)
Over	750 to 1000	6.10 (20)
(Extracted from ASME/ANSI Standard B30.5-2004) SAFE MAINTENANCE PRACTICES		

Required clearances for operation near high voltage power lines

Careful planning and supervision offer better protection than any known hardware.

Insulated boom cages, proximity warning devices, and insulating links have limitations and can fail without warning.

Insulated boom cages and links only protect part of the crane and can break down electrically if contaminated with dust and water.

Operation of proximity warning devices can be affected by different arrangements of power lines, the movement of trucks, materials, and the crane itself, and other influences.

Relying on any of these devices could be dangerous because users may think they are providing protection when in fact they are not.

If any part of the crane or rigging contacts a high voltage line, the safest procedure for the operator is to stay at his post until the contact is cleared, or the power has been shut off.

Do not allow anyone on the ground to touch the machine.

If the operator must leave the machine, he should jump off, rather than climb off.

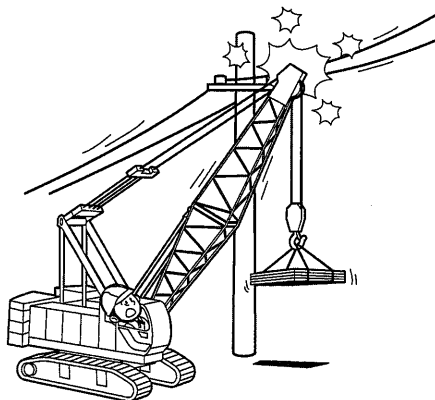

8. The load line can break if the hook block contacts the end of the boom.

This is called "two blocking".

Two blocking, for example, can be caused by hoisting the hook into the end of the boom or lowering the boom without paying out load line.

Two blocking can pull jibs and lattice booms over backwards or cause structural damage at boom or jib points.

Always keep space between the hook block and boom point.

Lower the hook when lowering the boom.

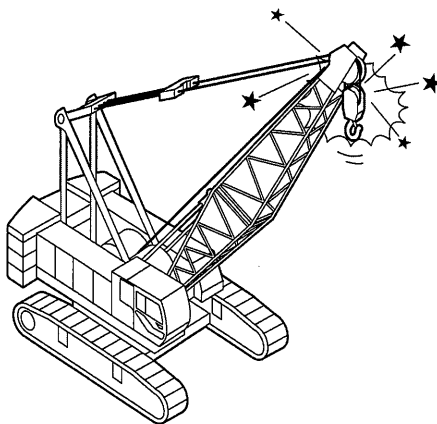

9. People can be injured if the hook, boom, load or outriggers are moved when personnel are nearby.

Make sure everyone is clear before moving the hook, boom, load or outriggers.

Do not move loads over people.

Do not allow the load to bump or catch on anything.

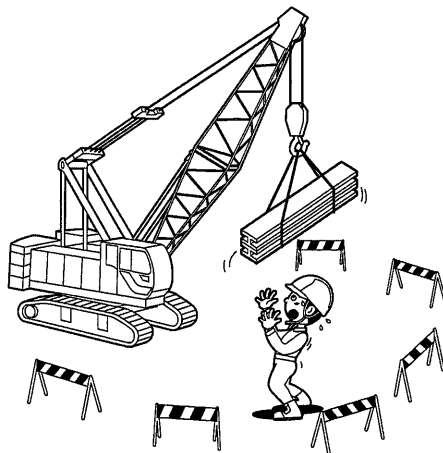

1

10. Rapid swings or sudden starts and stops can cause the hook and attached load to swing out of control.

Always start and stop movements smoothly and swing at speeds that will keep the load under control.

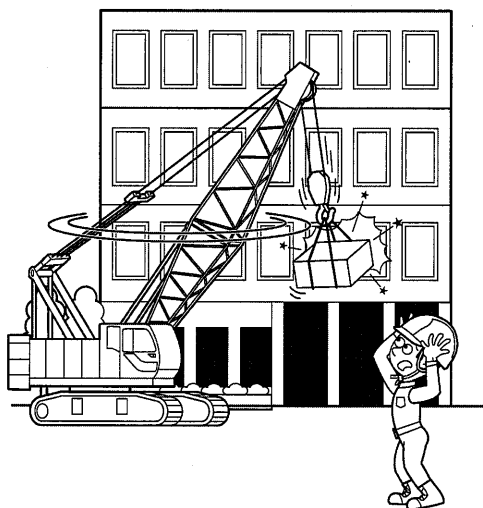

11. Dirty windows, darkness, bright sunlight, fog, rain and other conditions can make it difficult for the operator to see.

Keep windows clean.

Do not operate if you cannot see clearly enough to operate safely. Replace cracked or broken glass as soon as possible.

There are several specific safety signs on your machine.

Their exact location and description of the hazard are reviewed in this section.

Please take the time to familiarize yourself with these safety signs.

Make sure that you can read all safety signs. Clean or replace these if you cannot read the words or see the pictures.

When cleaning the labels use a cloth, water and soap.

Do not use solvent, gasoline, etc.

You must replace a label if it is damaged, missing or cannot be read.

If a label is on a part that is replaced, make sure a new label is installed on the replaced part.

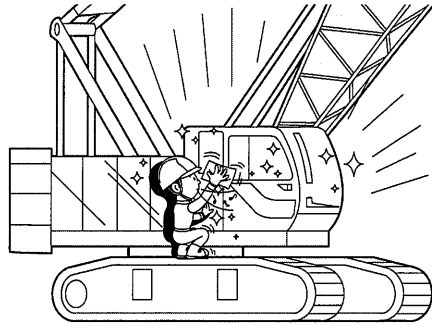

12. Even light winds can blow loads out of control, collapse booms, or tip cranes. Winds aloft can be much stronger than at ground level.

Do not lift loads if winds create a hazard. Lower the boom if necessary.

Moderate winds may create a hazard for long booms or loads with large surface areas.

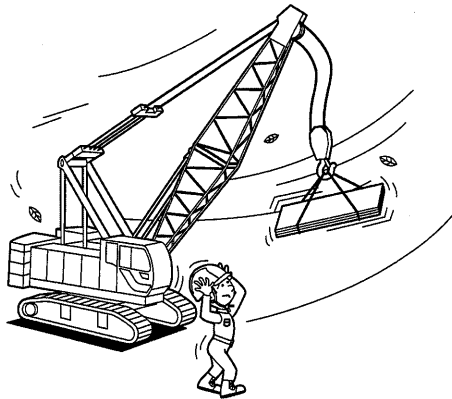

13. Carelessness in getting on and off equipment can result in a serious injuries.

Always wait until the machine has stopped.

Do not jump on or off.

Always use both hands and make sure you have good footing.

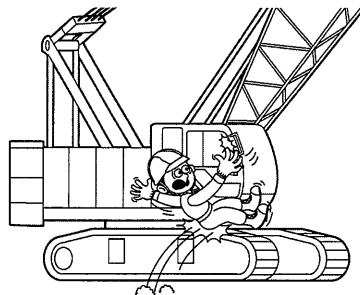

1

14. Slippery floors and steps, tools, trash, or other loose items can cause falls.

Keep the machine clean and dry.

15. Damaged crane booms may collapse.

Lattice type booms will be weakened by damaged chords, bent or missing lacings, or cracked welds. Inspect the crane boom daily for damage.

Do not use damaged booms.

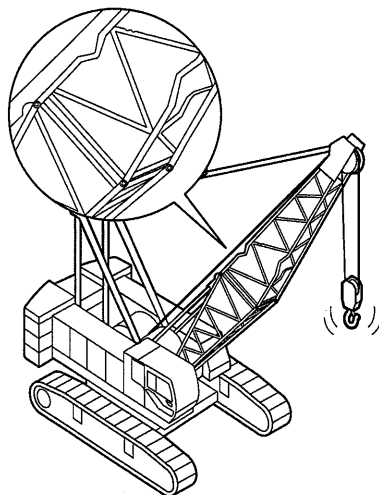

CAUTION

Due to the high strength steels used in booms and jibs, special repair procedures are required.

Consult your local authorized KOBELCO authorize distributor for instructions.

16. Crane booms can collapse if side loaded (pulled sideways).

Typical causes of side loading are rapid starts and stops while swinging, dragging a load sideways, winds, or lifting when the crane is not level.

Take care to avoid side loading.



17. If the load strikes the boom or the boom hits a building or other object, the boom may collapse. Never let the load or any other object contact the boom.

18. Boom suspension lines will stretch when the load is lifted and contract when the load is released. At high boom angles this may be enough to pull the boom backwards over the crane or collapse the boom stops.

When releasing loads be sure the boom never tightens against the backstops. Release loads slowly booming out if necessary while releasing.

19. The load will swing out of control if it is not directly beneath the boom point when lifted. This can side load the boom and may cause the crane to tip or collapse.

Always place the boom point directly above the load when lifting. Make certain all personnel stand clear of the load as it is lifted.

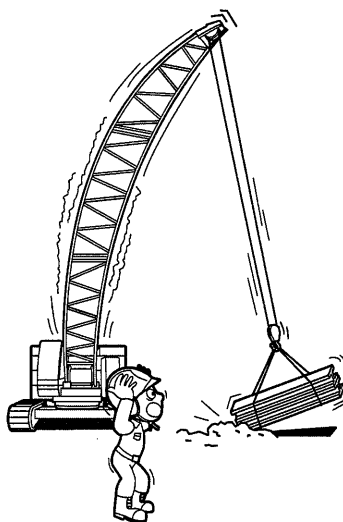

20. Trying to lift a load which is stuck, frozen or attached to something else may result in a tipping, boom collapse or other damage. Be sure that loads are free before lifting.

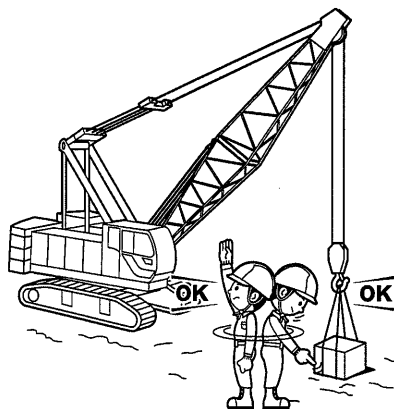

21. If there is not enough wire rope on the drum the rope can snap loose.

Keep at least 3 full turns of wire rope on drums when operating.

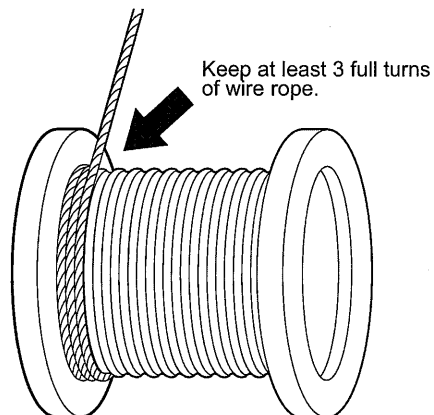

22. If foot brake pedals and locks are equipped on the crane, always keep your feet on the pedals while foot pedal brake locks are in use.

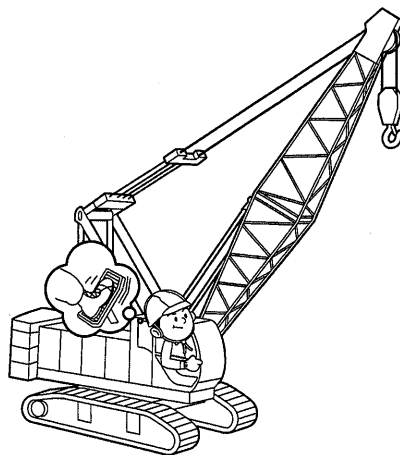

23. Trying to repair or adjust equipment with a suspended hook or load or with the boom raised could release machinery and let it move unexpectedly. Always lower the load to the ground and the boom onto proper cribbing before doing maintenance or repair work.

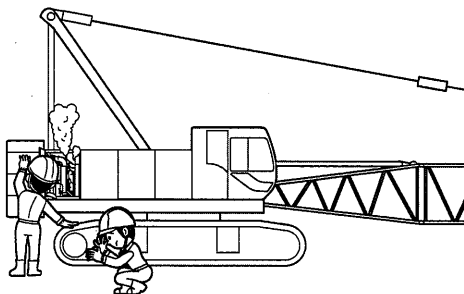

24. Pressure in hydraulic systems can be retained for long periods of time.
If not properly released before maintenance people attempt to work on the hydraulic systems, this pressure can let machinery move or cause hot oil and hose ends to shoot out at high speed.
Release system pressure before attempting to make adjustment or repairs.

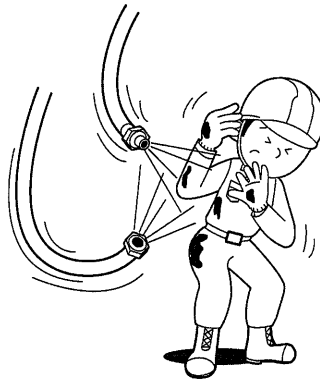

25. Pin-connected booms and jibs may fall if not properly supported when removing pins.
Make sure both ends of each boom and jib section are supported and the boom suspension lines completely slacked off before removing pins.
Never stand on, inside, or under booms or jibs during assembly or disassembly.

26. As with all heavy equipment, care must be taken when cranes are driven (traveled), whether on or off the job site.
Watch for people, electrical power lines, low or narrow clearances, bridge or road load limits, and steep hills or uneven terrain.
Use a signalman in close quarters.
Know the height, width and weight of your machine.
Set swing brake or lock before traveling.

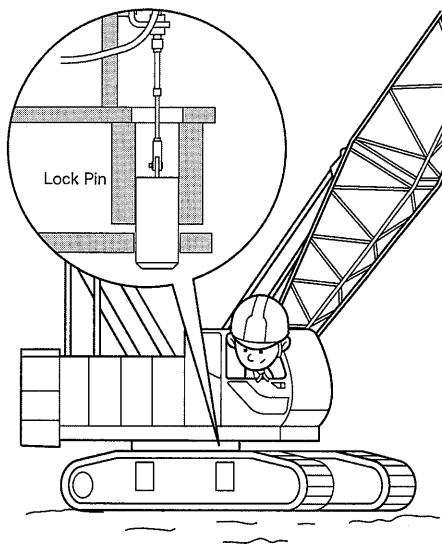

27. Load ratings for cranes are based on the machine being level and operated properly so that dynamic effects of operation do not increase the loadings on the crane.

Traveling a crane with a long boom or with a load suspended involves special hazards including the increased possibility of side loading or tipping.

Because of the many variables involved in pick and carry operations, the user must evaluate conditions and take appropriate precautions such as these :

- Follow the travel precautions listed in rule 26.
- Check the rating plate for limitations.
- Position the boom in line with the direction of travel.
- Reduce the maximum load while traveling to reflect operating conditions.
The safe load will vary depending on speed, crane, and other conditions.
- Travel slowly and avoid sudden stops and starts.
- Do not steer.
Otherwise a lifting load may swing and lateral load would be applied on the boom and would be dangerous.
- Avoid backing away from the load.
This could increase the radius and cause the machine to tip over.
- Use tag lines to keep loads under control.
- Keep the load close to the ground.
- Use the shortest boom possible.

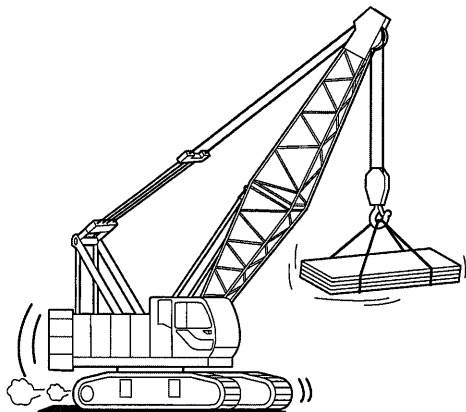

28. Using two or more cranes to lift a load involves many hazards not normally encountered in single crane lifts.

Multi-crane lifts must be carefully engineered, keeping the following points in mind.

- Since the load is not freely suspended, careful engineering studies must be made to ensure that the load carried by each machine is less than its rated capacity.
- Make sure slings are arranged to divide the load as planned.
- Review the lifting plan with operators, signalmen and other crew members before beginning the lift.
- Carefully coordinate crane movements through every stage of the lift.
- Avoid boom side loading (see #16).

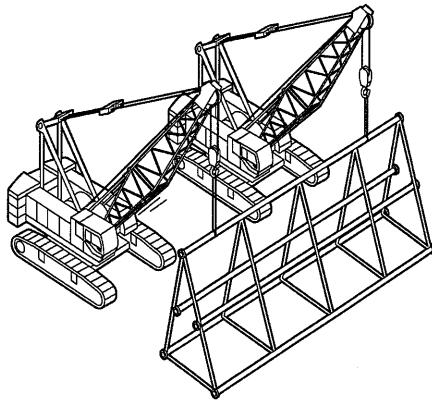

29. Leaving a machine unattended can be very dangerous.

Before leaving his seat, the operator must take the following steps to prevent his machine from moving :

- Since the load is not freely suspended, careful engineering studies must be made to ensure that the load carried by each machine is less than its rated capacity.
- Lower the load or bucket to the ground.
Lower the boom when necessary.
- Set the swing brake or lock.
- Set all drum locks.
- Set parking brakes.
- Set propel brakes or locks on crawler machines.
- Disengage the engine clutch or shut off the engine.
- Place the function lock lever in the shut down position.

30. The operator or person in charge should see that :

- Loads are well secured before being lifted.
- Slings are not kinked or damaged.
- The load is well balanced, and the hook block is adequate for the load to be lifted.
- Slings are properly arranged on the hook.
- Sudden stops and starts are avoided.
- The hoist line is vertical before starting the lift.
- The crane hook is equipped with a properly functioning retainer latch.
- Crane loads, grapples, or buckets do not pass over the heads of workmen nor in any way endanger their safety.

All loose objects must be removed from the load.

Non-operating personnel should be warned, or told to leave the immediate area, when making crane lifts.

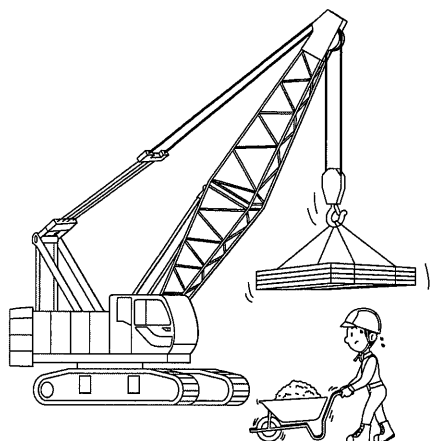
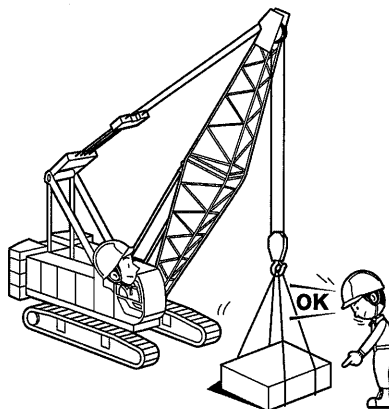

31. Always replace protective guards and panels before operating the machine whenever they become dirty or damaged.

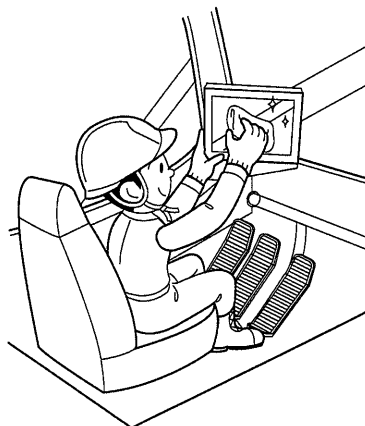

32. Never wear loose clothing rings or other objects which may become entangled in the moving machinery.

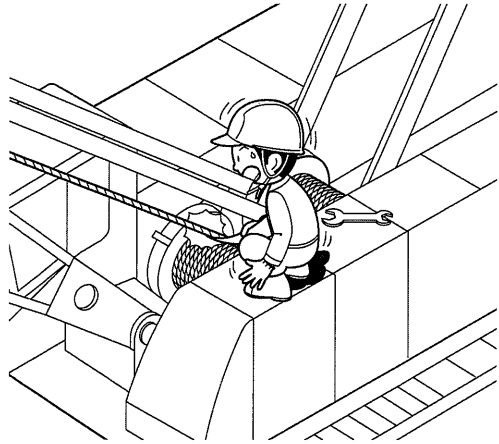

33. The operator should test the winch brakes when a load is first lifted, and when the load is only a few inches above its starting position, to assure the ability of the brakes to hold the load while it is aloft.

34. When refueling, be careful not to smoke. Stop the engine, and keep metal funnels in contact with the fuel tank filler pipe to prevent static electrical sparks from igniting the fuel. Turn off cab heater (if equipped) while refueling, and avoid refueling near an open flame.

WARNING

Make sure to use light oil.
(However, replenish the fuel which matches the regional conditions in cold climates.)
If the fuel other than the specified type is used or gasoline, kerosene and alcohol group fuels are supplied or used after mixing them, it may cause malfunction due to the sliding defect on the fuel sliding section in the injection pump and/or in the injector, or it may adversely affect the engine and result in a damages.
Check that the fuel is the specified product when fueling to your vehicle.
If a wrong product was supplied, thoroughly drain it.
If the engine is started with the wrong fuel filled, it is very dangerous because it may cause fire disaster or damage to the engine.

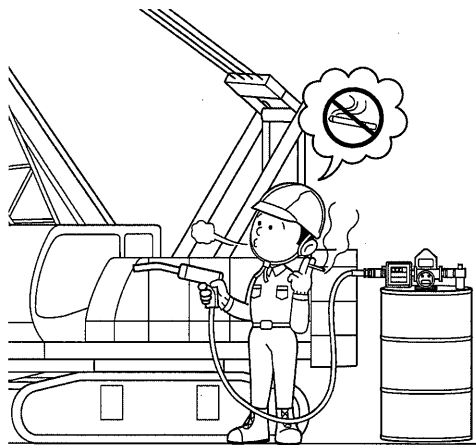

35. If an overheated condition necessitates an engine shutdown, use extreme care when checking the radiator, if possible, wait for radiator to cool.
Use a heavy cloth and gloves to protect yourself while slowly loosening the cap.
Wait until the sound and fluid flow stops.
Then remove the cap.
36. Be careful where you park your machine.
Do not leave it where there is a chance of a bank caving in on it, or in a low spot where heavy rains may wash out the footing.
37. When leaving the crane unattended, always remove keys and lock all cab doors to prevent unauthorized person from tampering with the machine and possibly injuring themselves or others.
38. Other operating precautions
 - Do not perform lifting work with the crawler retracted.
 - Never work in over load condition.
 - Avoid free fall work as much as possible.
 - Be careful of slipping on slope road.
 - Do not use the main and aux. hook simultaneously from the boom point.
 - Take slow speed in landing of load on the ground.

MEASURES FOR RADIO TRANSMITTERS

When working in the vicinity of a transmitting antenna for a broadcasting station, the boom could act as a large antenna, and could become electrified.

High voltage of electricity may be generated at the hook end, and the hook could become heated.

If this happens, do not touch the hook.

Electrical shock, or burning could result.

Ground personnel should be warned to stay away from the machine.

MEASURES FOR LIGHTNING

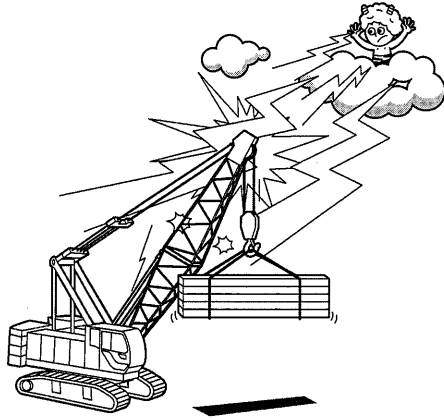

1. When lightning storms are generated and lightning bolts are anticipated, immediately take the following steps :
 - (1) Stop the work, and lower the load onto the ground.
When the boom (or tower) can be lowered, lower it onto the ground.
 - (2) Engage the brakes and locks (winch and swing) and stop the engine.
Turn off the power source of the load safety device and main switch.
 - (3) Advise all personnel to stay away from the surrounding area of the machine.

2. If a lightning strike occurs check the machine before operating it.
 - (1) Check for burns and damage.
 - (2) Check the electrical devices and load safety device for performance.
 - (3) Check each function for abnormality.

MEASURES FOR EARTHQUAKE



1. When earthquakes occur, immediately take the following step :
 - (1) Stop the work, and lower the load and hook onto the ground.
When the boom (or tower) can be lowered, lower it onto the ground.
 - (2) Engage the brakes and locks (winch and swing), stop the engine, and turn off the electrical power of the main switch and load safety device.
 - (3) Advise all personnel to stay away from the surrounding area of the machine.

2. After the earthquake is over, check the machine before operating.
 - (1) Check each function for performance.
 - (2) Check the electrical devices and load safety device for performance.

1.4 SAFETY AT INSPECTION AND MAINTENANCE WORK

- Stop the engine during inspection and maintenance work.
- Do not weld other object to the boom since it may cause weakening the boom strength.
(Prohibiting modification)

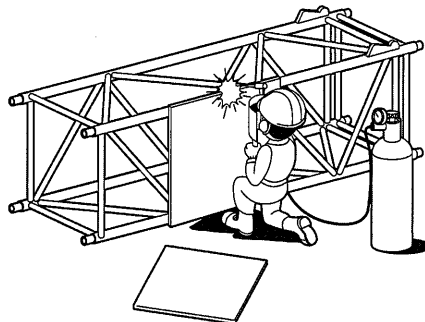

- Do not bring fire close during battery handling.



- Disconnect the battery cables during inspection and maintenance of electrical system.

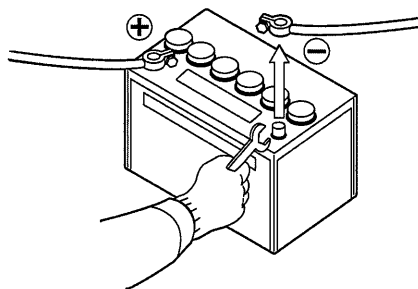

- When removing the radiator cap straight after engine stop, take extra care about internal high pressure and high temperature. Slowly remove the radiator cap after the coolant temperature becomes lowered to release pressure.



- Machine parts are hot straight after engine stop. Do not touch them.
- Perform the inspection and maintenance work specified by law.

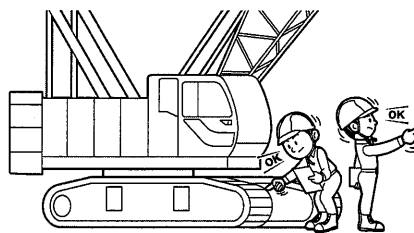

- Keep machine always in order, tidy and clean.

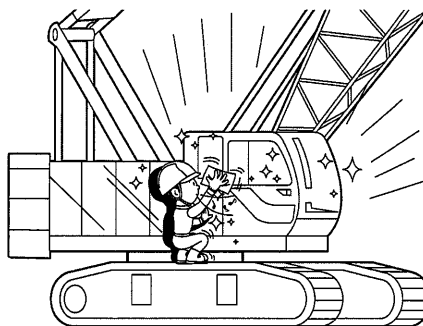

- Whenever any fault is found, repair immediately.

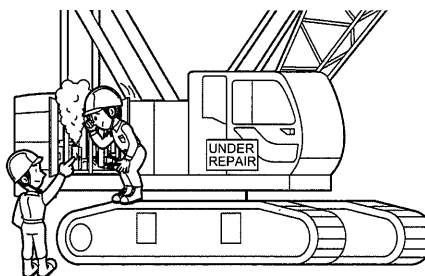

- Ensure to use genuine wire rope, guy line or oil.

CAUTION

Warranty is voided if the failure is caused by use of parts and components other than KOBELCO genuine parts.



1

- Do not use fuel other than specified one.

WARNING

Use ultra low sulfur diesel fuel only (S50 : sulfur content lower than 50 ppm).
If fuel other than specified one is used, adverse affect may be caused to the engine or diesel particulate filter and white smoke or failure may be resulted.

- Use recommended engine oil.

CAUTION

In order to keep good function of the diesel particulate filter, it is recommended to use the specified brand (recommended) engine oil.

1.5 SAFETY DURING ASSEMBLY AND DISASSEMBLY WORK

- Ensure to wear safety belt and other protective gear during high place work.

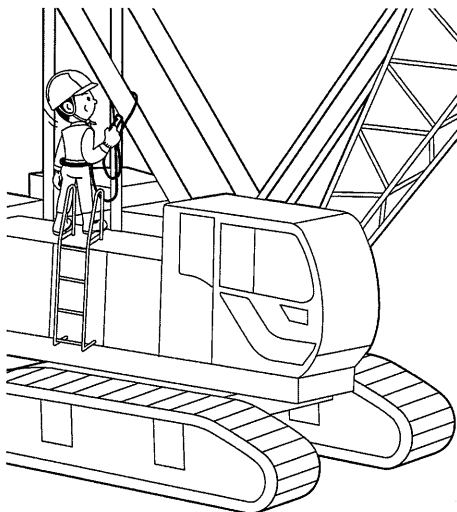

- Ensure to secure the machine to the trailer firmly during transportation. Strictly observe the road traffic regulation on dimension and weight during transportation.
- Do not cause overloading on the trailer.

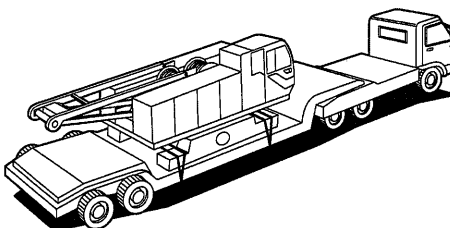

1.6 CAUTIONS IN HANDLING OIL AND PAINT

CAUTIONS IN HANDLING LUBRICATING OIL AND GREASE

1. Oil draining while they are hot may cause burns and is dangerous.
Drain them after cool down.
2. Getting them into eyes may cause inflammation.
Wear safety glasses etc in handling to prevent getting into eyes.
3. Getting them touched on skin may cause inflammation.
Wear protective gloves etc in handling to prevent them touching on skin.
4. Do not drink.
(Drinking them may cause diarrhea or vomiting.)
Keep them away from children to reach.

CAUTIONS IN HANDLING PAINT

1. Do not handle in the place with fire.
2. Handling place should be equipped with the localized exhaust system.
3. During painting and drying, exhaust system should work to prevent sucking steam.
4. During handling them, take care not to let them touch on the skin.
Wear organic gas mask, supplied-air respirator, safety glasses, protective gloves, hood, long sleeve work shirt, scarf etc as required.
5. If spilled, wipe off with cloths after scattering sands.
Paint adhered cloths, paint dregs or spray dust should be handled by soaking in the water.
6. After handling, wash your face, your hand, rinse your mouth and nasal well.
7. If paint adheres to your skin, wash out with soapy water. If painful or injured, see the doctor.
If painful or injured, see the doctor.
8. If paint get into your eyes, wash your eyes with much water and see the doctor as soon as possible.
9. If you feel bad by sucking steam or gas, stay calm in clean-air place and see the doctor as required.
10. In case of fire, use CO₂ gas or foam fire extinguisher.
11. Keep them with complete sealing and at the specified place where children can not reach.
12. Dispose them as industrial wastes.
13. Do not use for purpose other than specified (such as glue sniffing).

1.7 SAFETY EQUIPMENT (OPTION)

This machine is equipped with the following safety equipment as option.

For the detail of the safety equipment (option), refer to the article 8 "REFERENCE MATERIALS".

2. OPERATION

2.1	TERMINOLOGY OF MACHINE EACH PART	2-1
2.2	LOCATIONS AND TERMS OF OPERATING CONTROLS	2-3
2.2.1	HANDING LEVER AND PEDAL	2-4
2.2.2	OPERATING SWITCHES	2-11
2.2.3	VARIOUS SETTING OF MONITOR	2-39
2.2.4	WIND SPEED SENSOR INSTALLATION (OPTION)	2-49
2.2.5	AIR CONDITIONER	2-50
2.2.6	AM/FM RADIO	2-56
2.2.7	1WAY CALL (TRANSMITTER)	2-64
2.2.8	CAMERA MONITOR (OPTION)	2-65
2.3	CRANE OPERATION	2-68
2.3.1	ADJUSTING THE OPERATOR'S SEAT	2-68
2.3.2	GETTING ON OR OFF THE OPERATOR SEAT	2-70
2.3.3	STARTING AND STOPPING THE ENGINE	2-71
2.3.4	AUTO IDLE STOP FUNCTION	2-85
2.3.5	FUNCTION LOCK LEVER	2-88
2.3.6	PROPELLING OPERATION	2-89
2.3.7	SWINGING OPERATION	2-92
2.3.8	BOOM RAISING/LOWERING OPERATION	2-95
2.3.9	HOOK RAISING/LOWERING OPERATION	2-99
2.4	FREE FALL OPERATION (OPTION)	2-107
2.5	CLAMSHELL OPERATION	2-114
2.5.1	PREPARATION WORK	2-115
2.5.2	CLAMSHELL WORK	2-119
2.6	HANDLING OF HYDRAULIC TAGLINE (OPTION)	2-120
2.7	HANDLING OF VIBRO HAMMER	2-123
2.8	HANDLING OF REEVING WINCH (OPTION)	2-126
2.8.1	PREPARATION BEFORE HANDLING REEVING WINCH	2-127
2.8.2	HANDLING PROCEDURE OF REEVING WINCH	2-129
2.9	OPERATION IN WEATHER CHANGE AND SPECIAL CIRCUMSTANCE	2-134
2.9.1	CAUTION AGAINST WIND	2-134
2.9.2	CAUTION AGAINST ELECTRIC SHOCK	2-145
2.9.3	CAUTION AGAINST RADIO WAVE INTERFERENCE	2-147
2.9.4	CAUTION AGAINST LIGHTNING	2-148
2.9.5	COUNTERMEASURE AGAINST EARTHQUAKE	2-149

2. OPERATION

2.1 TERMINOLOGY OF MACHINE EACH PART

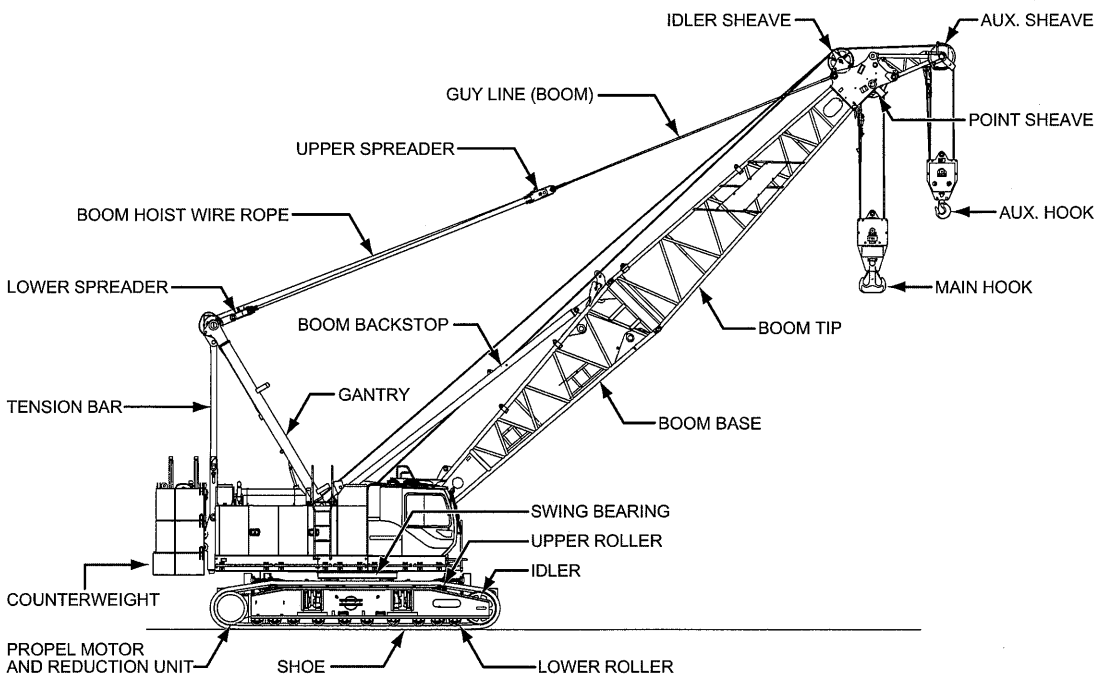

2

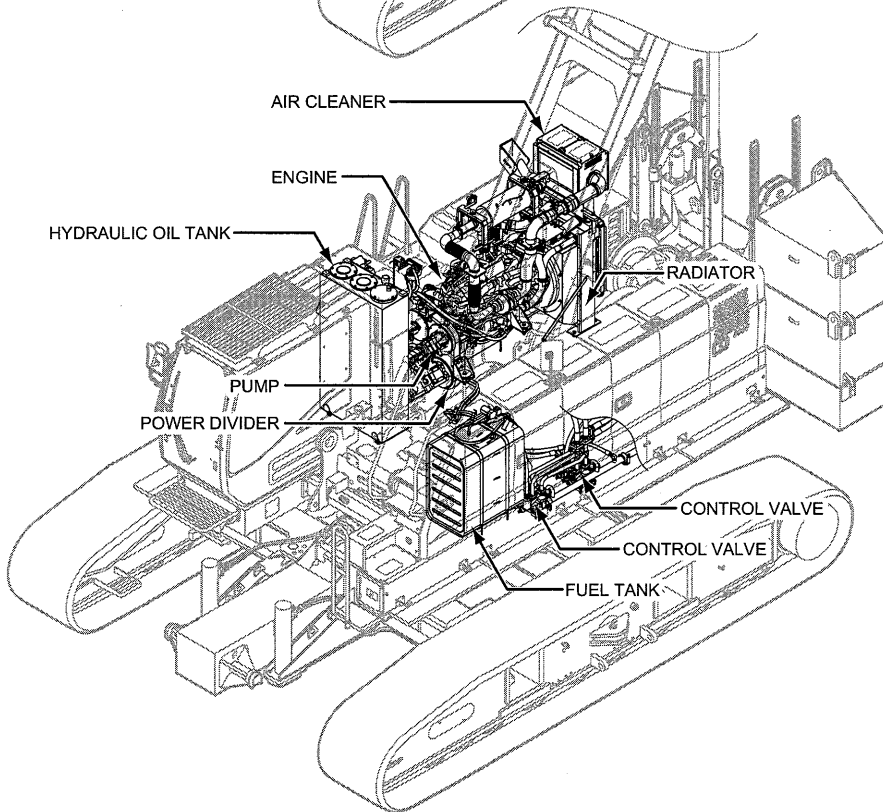
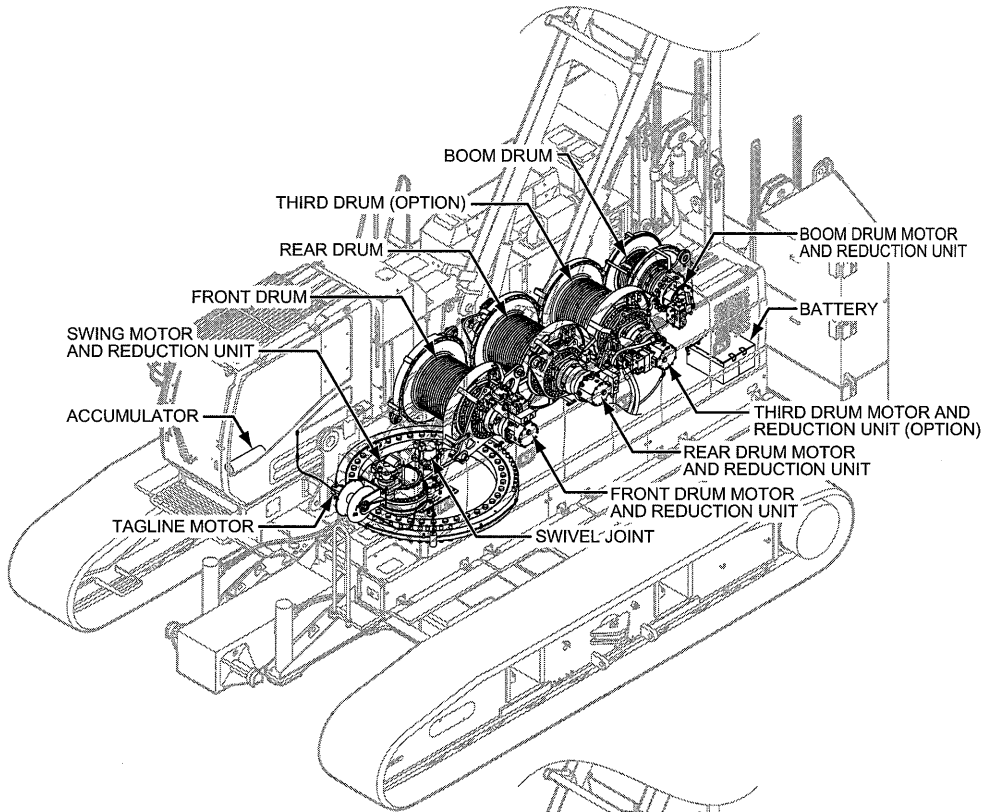

2.2 LOCATIONS AND TERMS OF OPERATING CONTROLS

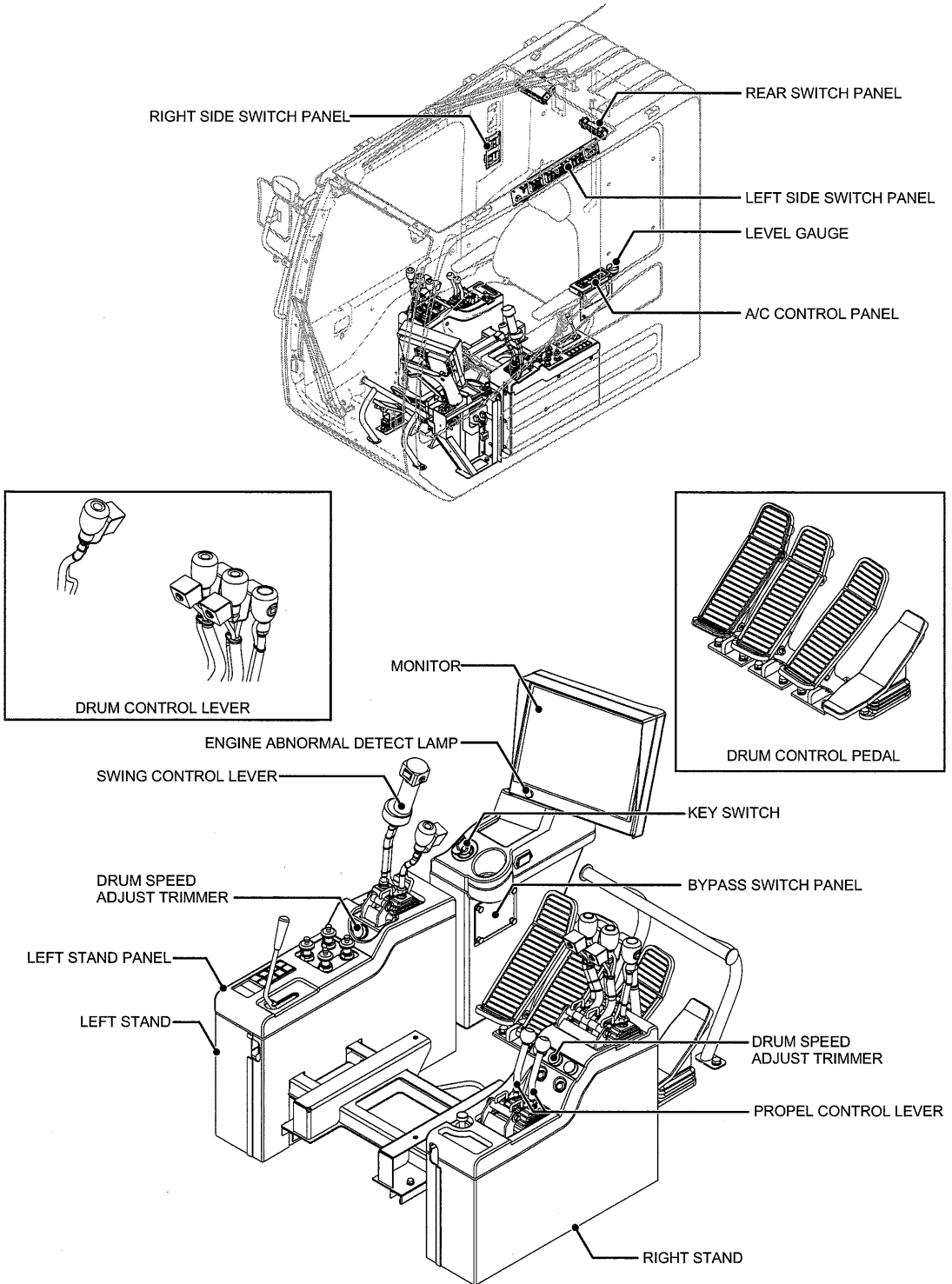

2.2.1 HANDING LEVER AND PEDAL

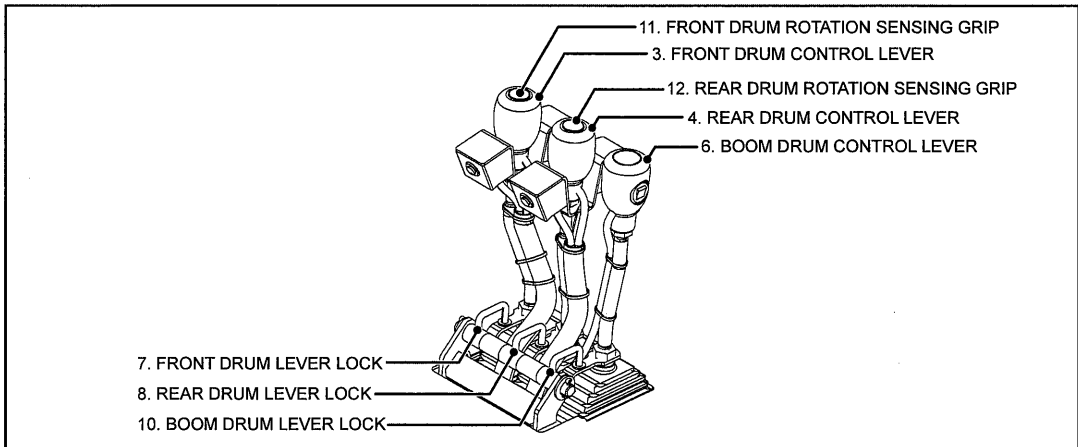
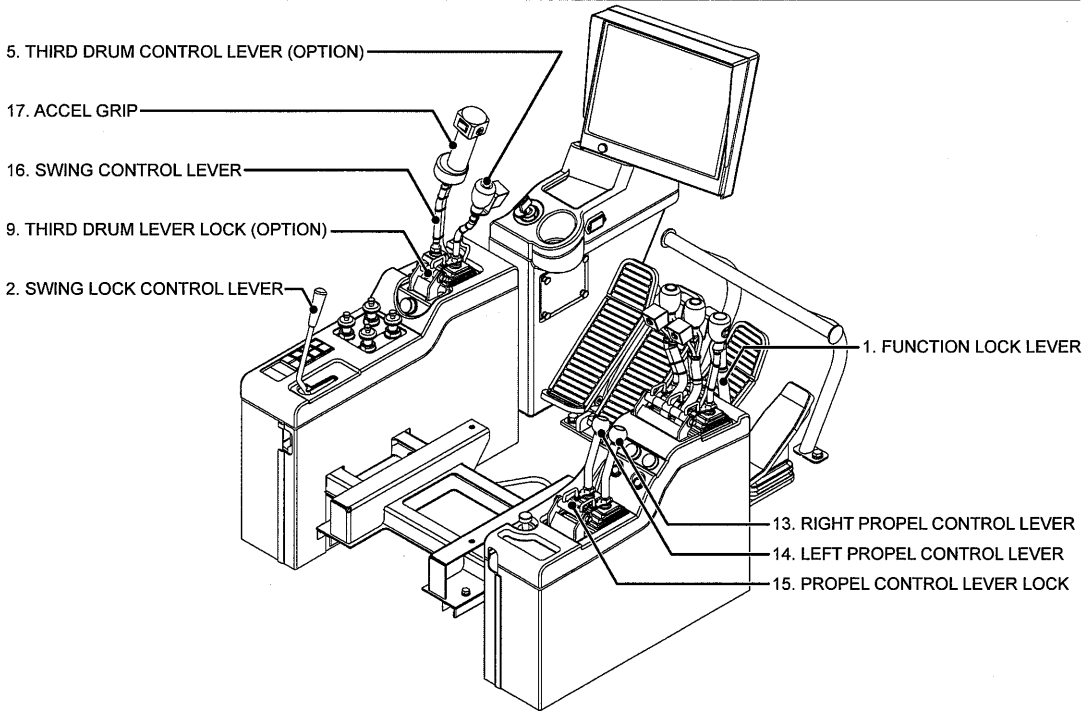
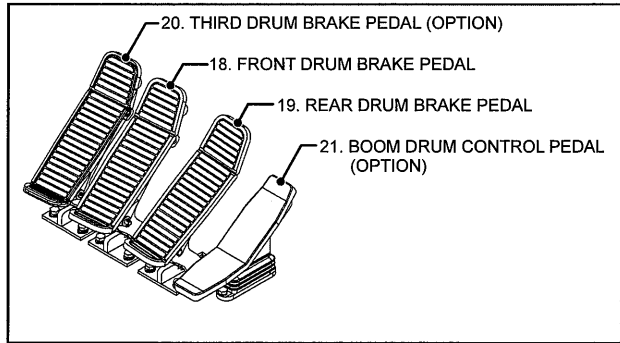
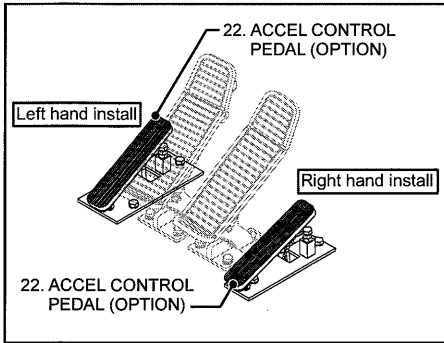

This article explains levers and pedals in the operator's cab.

Refer to the article "CRANE OPERATION" for the explanation of control based on actual work.

1. FUNCTION LOCK LEVER

Function lock lever is provided as safety device to prevent unexpected machine movement even operator's body touches the control lever during getting to or from the operator's seat.

- **Lock position :**
Hook raising, boom raising, propel and swing motion becomes non operational.
- **Work position :**
Hook raising, boom raising, propel and swing motion becomes operational.

Turn the function lock lever to "WORK" position when the machine is operated.

Whenever leaving from the operator's seat, ensure to stop the engine and turn the function lock lever to "LOCK" position.

Ensure to turn the function lock lever to "LOCK" position at work completion or at transportation of machine.

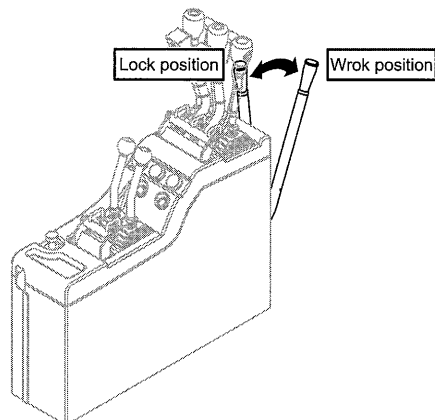

2

2. SWING LOCK CONTROL LEVER

This lever is to insert the lock pin from the upper machinery to the pin catch on the lower machinery to secure the upper machinery or release the pin to make upper machinery swing freely.

Ensure to insert the swing lock pin at the work completion or at the transportation.

- **Lever lock position :**
Upper machinery secured.
- **Lever release position :**
Upper machinery released.

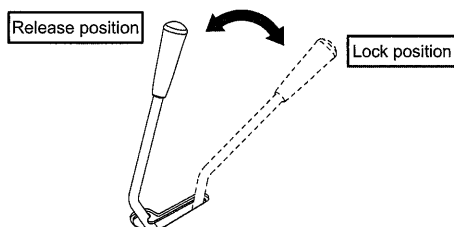

DRUM CONTROL LEVER

- 3. FRONT DRUM CONTROL LEVER
- 4. REAR DRUM CONTROL LEVER
- 5. THIRD DRUM CONTROL LEVER (OPTION)
- 6. BOOM DRUM CONTROL LEVER

These levers are to start, control and stop the front, rear third and boom drum.

Each lever drives and controls the drum such as pulling backward to raise, neutral and pushing forward to lower.

Each lever is held at the position due to detent.

* Detent : Function to prevent lever returning.

- 7. FRONT DRUM LEVER LOCK
- 8. REAR DRUM LEVER LOCK
- 9. THIRD DRUM LEVER LOCK (OPTION)
- 10. BOOM DRUM LEVER LOCK

Engage each lever lock with the lever at neutral position to prevent unexpected movement of lever by touching the operator's body.

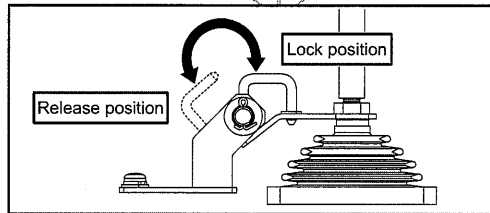
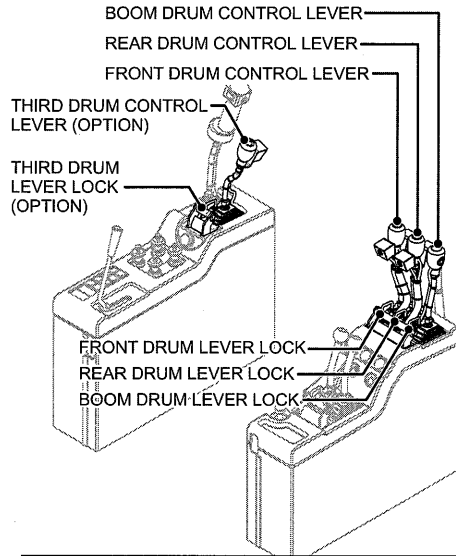
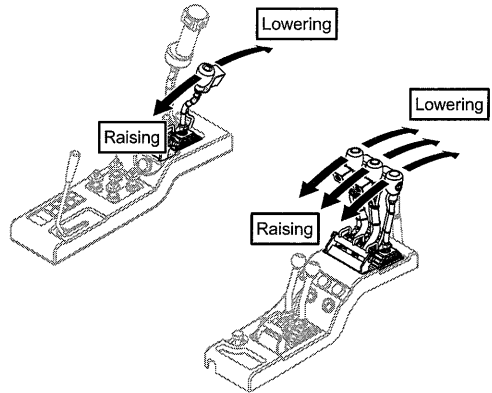

- 11. FRONT DRUM ROTATION SENSING GRIP
- 12. REAR DRUM ROTATION SENSING GRIP

When the drum rotation sensing switch is turned to "ON", operator can sense the front and rear drum rotation by top movable portion of the front and rear drum control lever.

The drum sensing is provided to sense the start and condition of the drum rotation on the top face of the lever grip. High speed rotation or free fall of the drum may not be sensed.

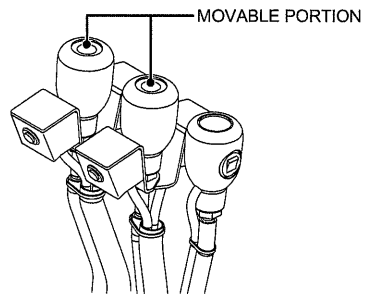

PROPEL CONTROL LEVER

13. RIGHT PROPEL CONTROL LEVER

14. LEFT PROPEL CONTROL LEVER

These lever are to drive, control and stop propel forward or propel backward.

Furthermore, pivot turn, spin turn or normal turn can be done for direction change.

Each lever drives and controls the propel motor such as pushing forward for forward propel, neutral and pulling backward for backward propel.

Special attention is required since the lever moving direction has to be reversed based on the direction of the lower machinery against the upper.

15. PROPEL CONTROL LEVER LOCK

Engage each lever lock with the lever at neutral position to prevent unexpected movement of lever by touching the operator's body.

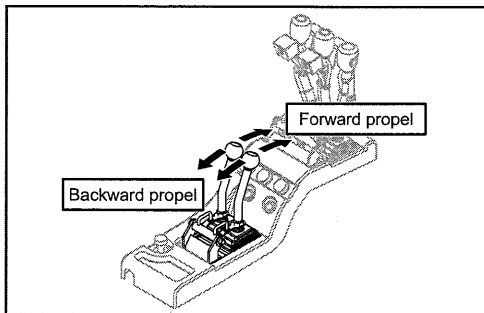

2

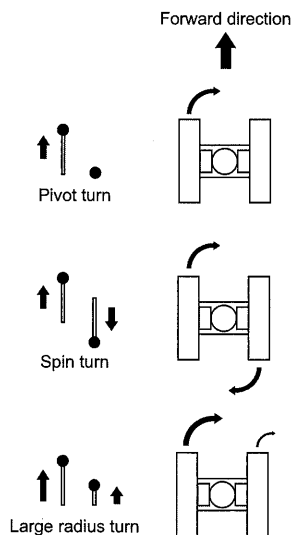
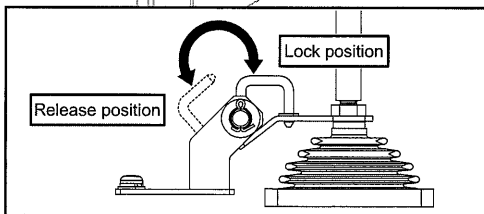
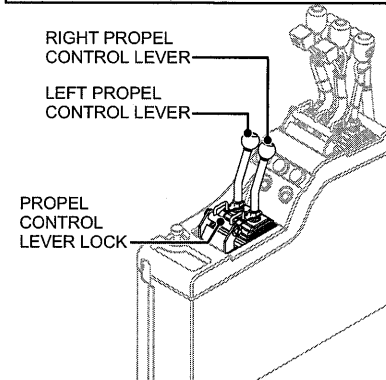

SWING CONTROL LEVER

16. SWING CONTROL LEVER

This lever is to start, control and stop the left and right swing motion of the upper machinery.

Pulling the lever backward is to swing right and pushing lever forward is to swing left and the lever returns to neutral automatically.

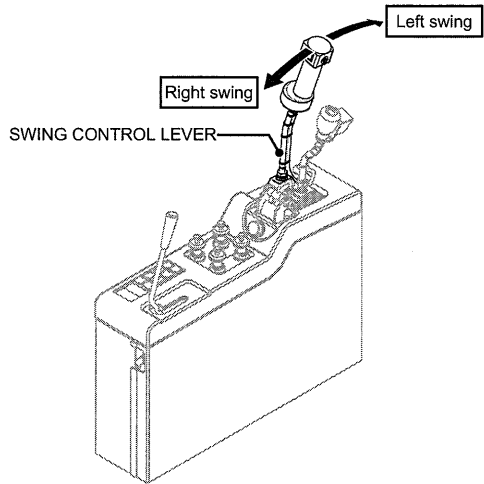

17. ACCEL GRIP

The engine speed adjustment is done with the accel grip installed on the swing lever.

Accel grip has 120 degrees control range and can be set to any position.

- **Counterclockwise (left turn) :**
Speed increase
- **Clockwise (right turn) :**
Speed decrease

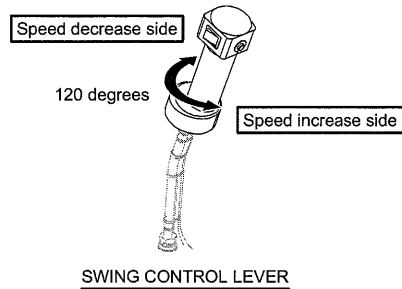

BRAKE PEDAL FOR FREE FALL

18. FRONT DRUM BRAKE PEDAL
19. REAR DRUM BRAKE PEDAL
20. THIRD DRUM BRAKE PEDAL (OPTION)

These are brake pedal of each drum to make free falling and stop falling of hook and the lifting load.

Make free fall, brake or stop while pressing the brake pedal.

In order to hold the hook or lifting load during the free fall operation, press the brake pedal to engage the pedal lock.

Pressing the brake pedal during raising or power lowering operation does not engage the brake.

Only during free fall operation, brake is engaged.

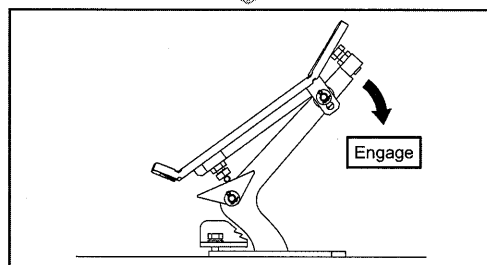
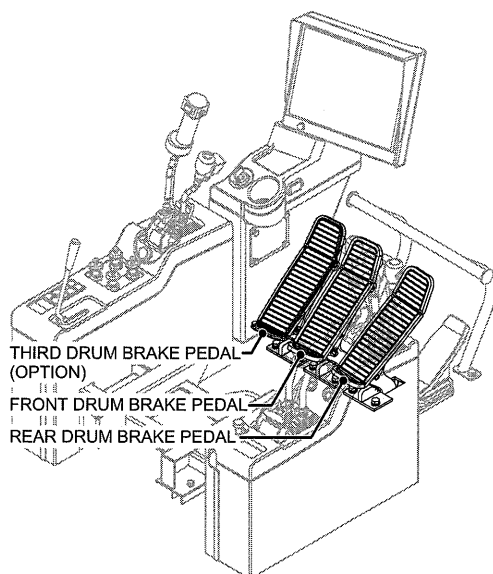

CONTROL PEDAL

21. BOOM DRUM CONTROL PEDAL (OPTION)

This pedal can control the boom drum instead of the boom hoist control lever.

The boom rises up with the control pedal pushed toward near side and the boom lowers with the control pedal pushed far side.

The pedal returns automatically.

As for the boom drum control lever and boom drum control pedal, whichever is used first over-rides the other.

Condition to install

- **Right hand installation :**
In case of no accel pedal.
- **Left hand installation :**
In case of no third drum brake pedal.

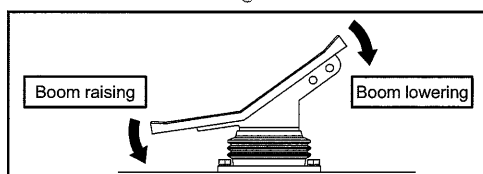
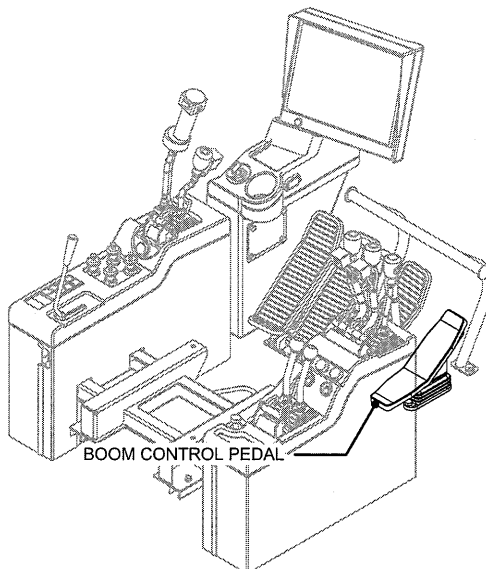

22. ACCEL CONTROL PEDAL (OPTION)

During work using swing lever, the accel control pedal can be used instead of the accel grip control.

Pressing the control lever to far side increase the speed and the pedal returns automatically.

As for the accel grip and the accel control pedal, whichever is used first to speed increase side over-rides the others.

Condition to install

- **Left/right installation :**
In case of no third/boom pedal.
- **Right installation :**
In case of no boom drum pedal.
- **Left installation :**
In case of no third drum pedal.

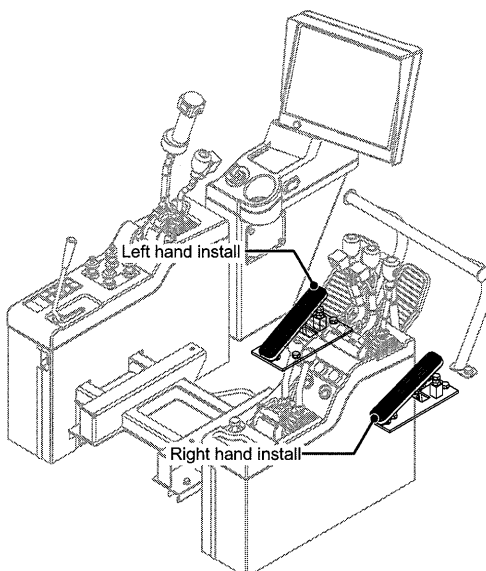

ACCEL CONTROL PEDAL (OPTION)

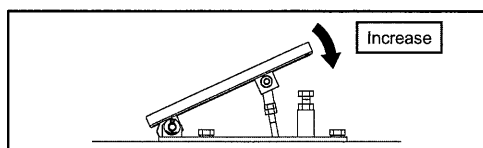

2.2.2 OPERATING SWITCHES

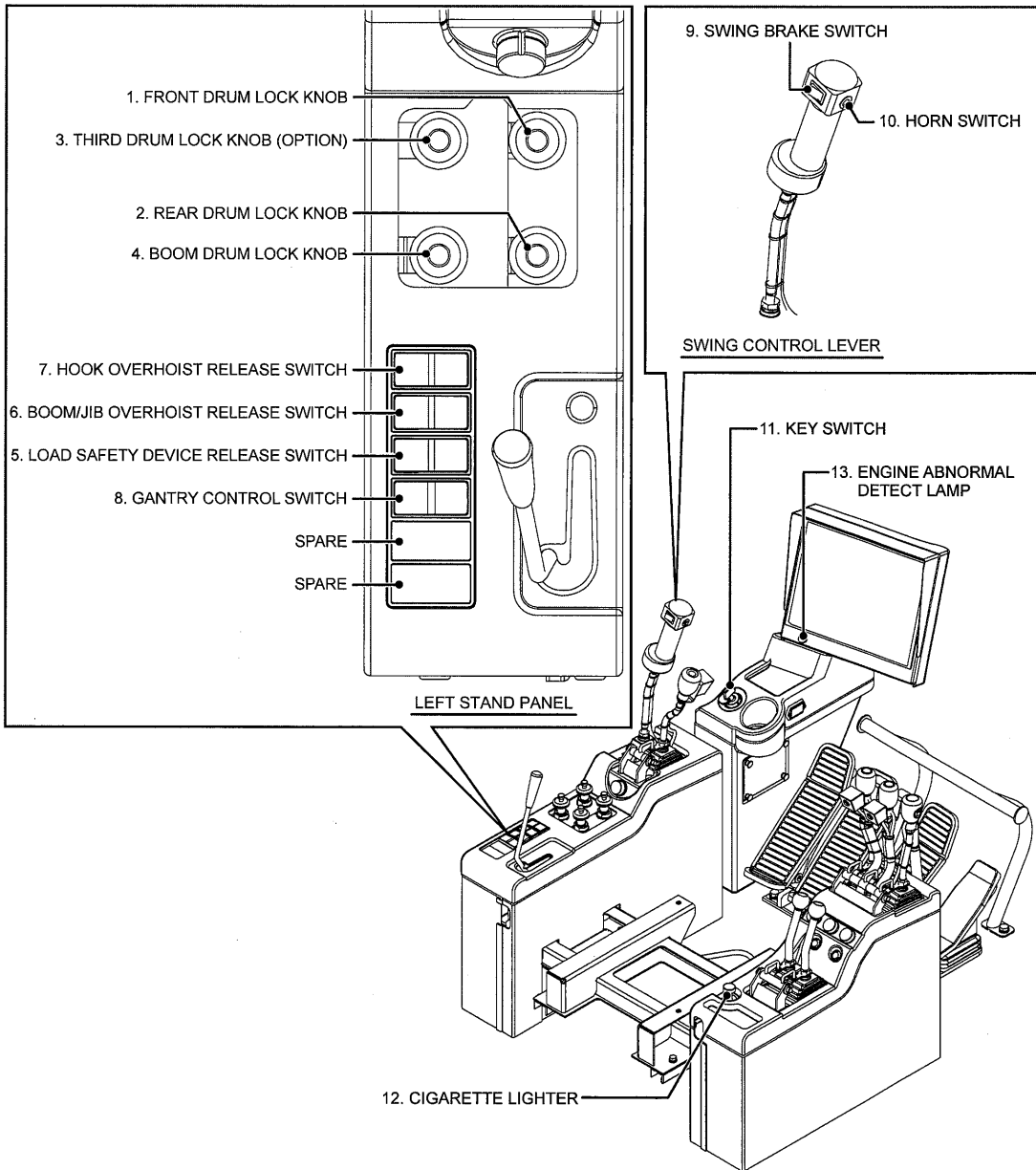

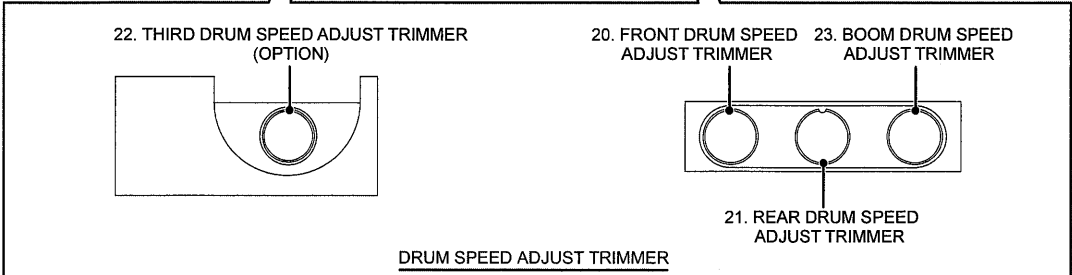
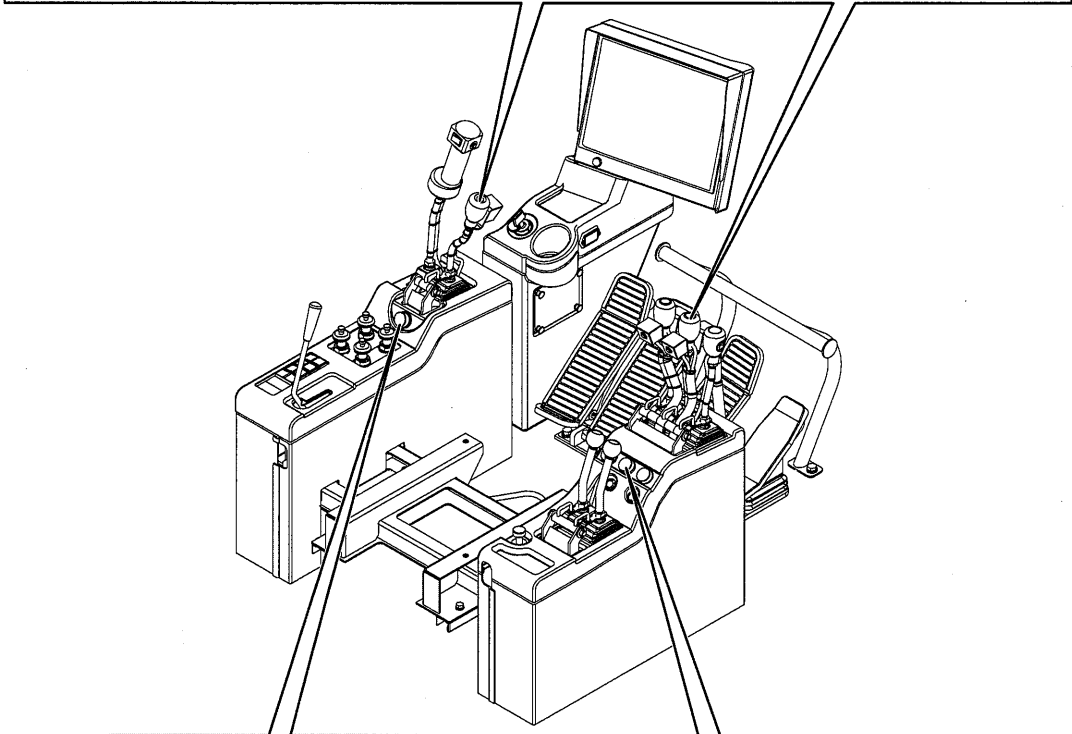
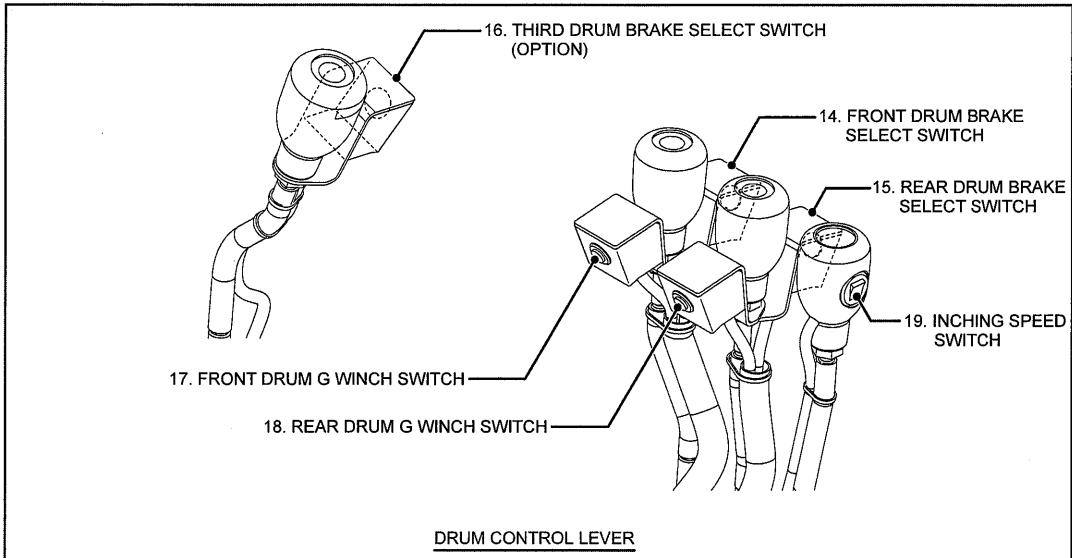

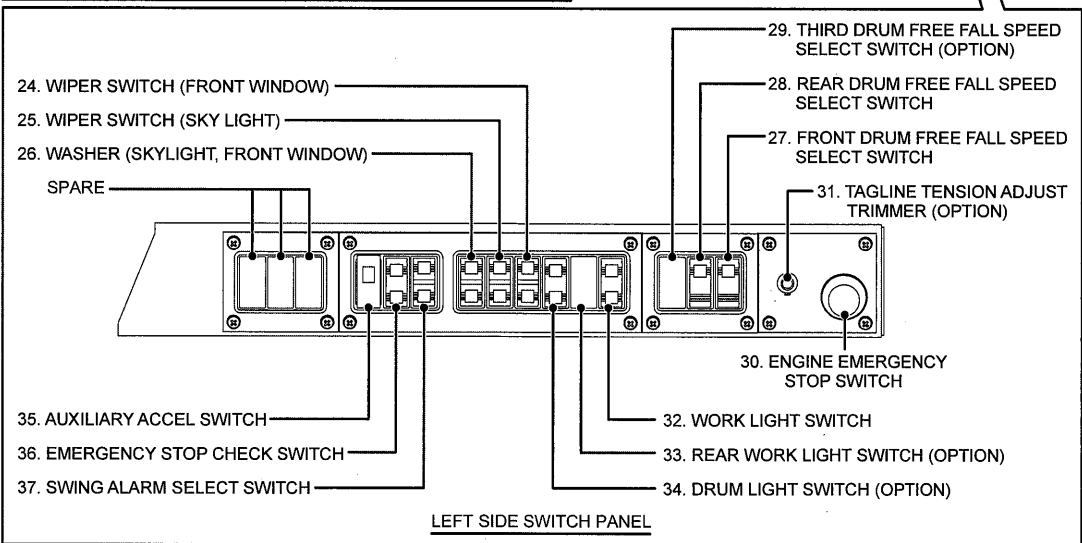
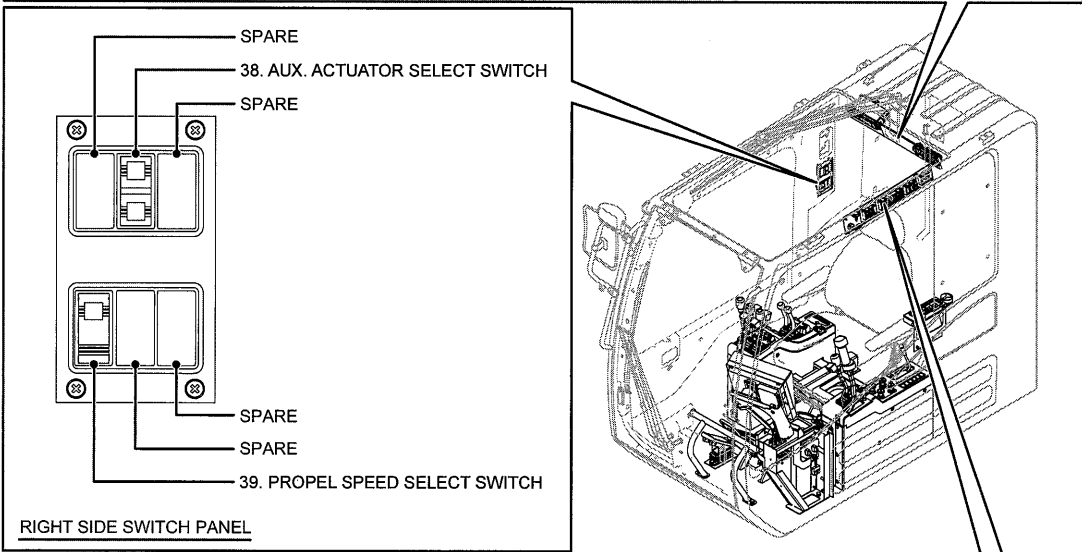
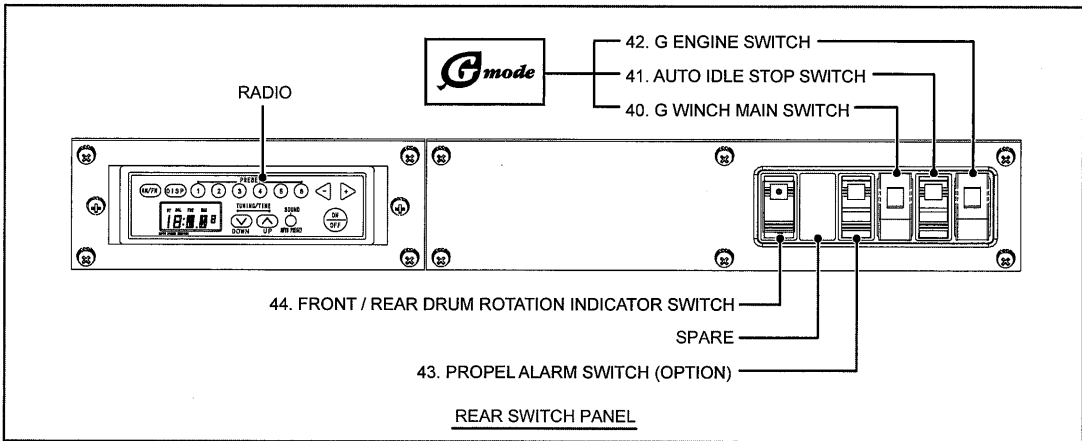

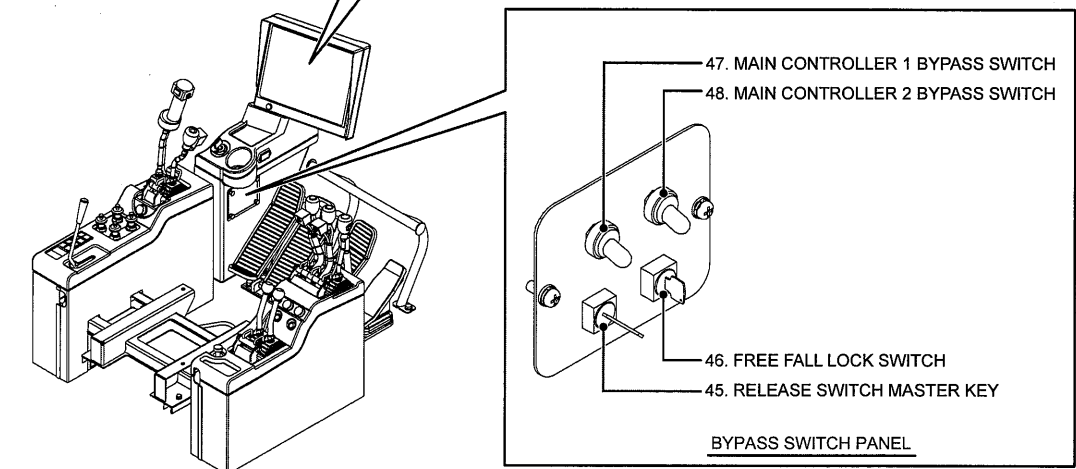
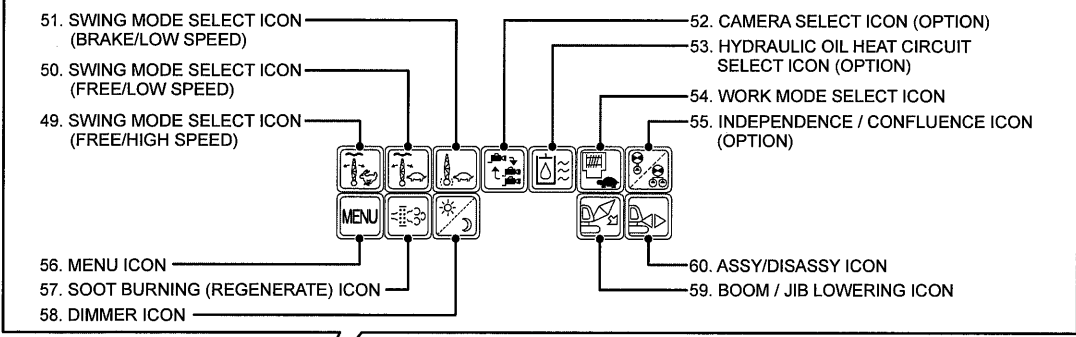
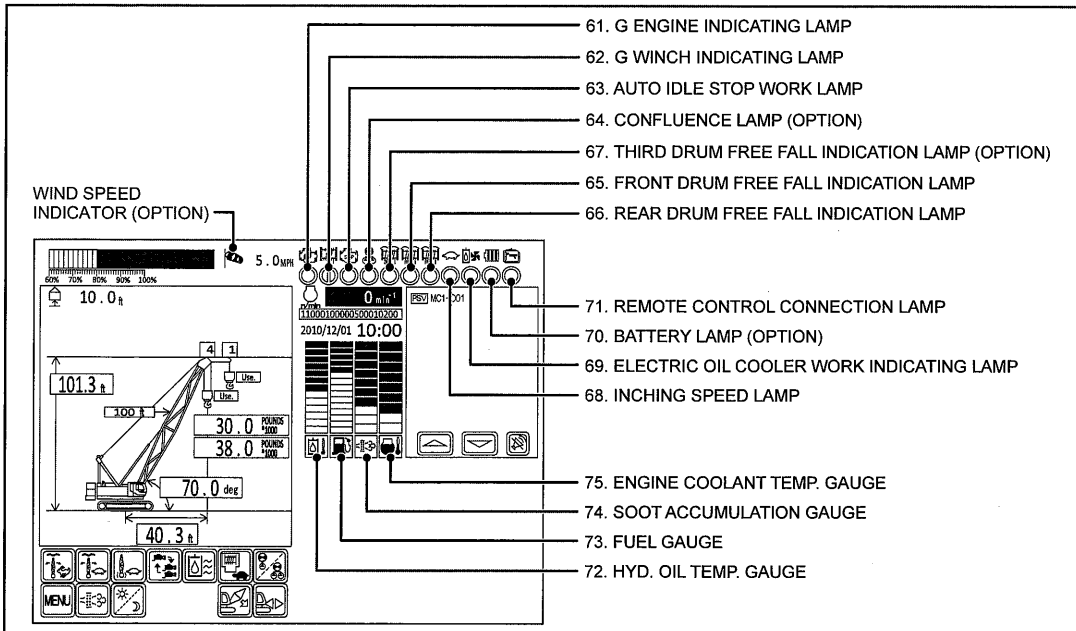

Each switch is explained here.

Refer to the article "CRANE OPERATION" for the explanation of control based on actual work.



LEFT SIDE PANEL

1. **FRONT DRUM LOCK KNOB**
2. **REAR DRUM LOCK KNOB**
3. **THIRD DRUM LOCK KNOB (OPTION)**
4. **BOOM DRUM LOCK KNOB**

Engage the drum lock by pulling up the drum lock knob when the drum is not used for long time.

To release, push the knob while pushing the button on the knob top.

These knobs are to lock the drum to for safety during lowering the lifting load or boom.

 (Lock)	Pull up the knob to engage the drum lock.
 (Release)	Push down the knob to disengage the drum lock.

Stopping the engine issues alarm sound to expedite drum lock for 4 seconds.

⚠ DANGER

Do not engage the drum lock while the hook is being lowered.

Do not control the hook to lowering side while the drum lock is engaged.

Drum and drum lock may be damaged.

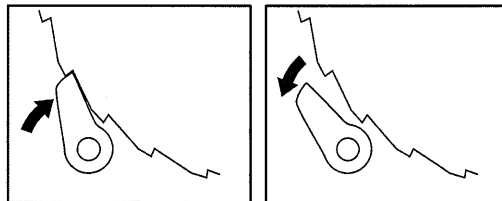
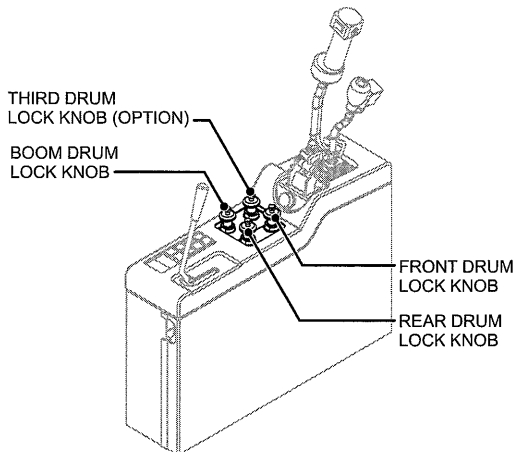

5. LOAD SAFETY DEVICE RELEASE SWITCH

If the lifting work has to be continued after the load safety device stops the operation by some reason, this switch release the auto stop function.

- **Release**

Only during the time when this switch is turned to release side, auto stop function of the load safety device can be released.

The switch can automatically return when the switch is hand released.

This switch is functional only when "45. RELEASE SWITCH MASTER KEY" is turned to release side.

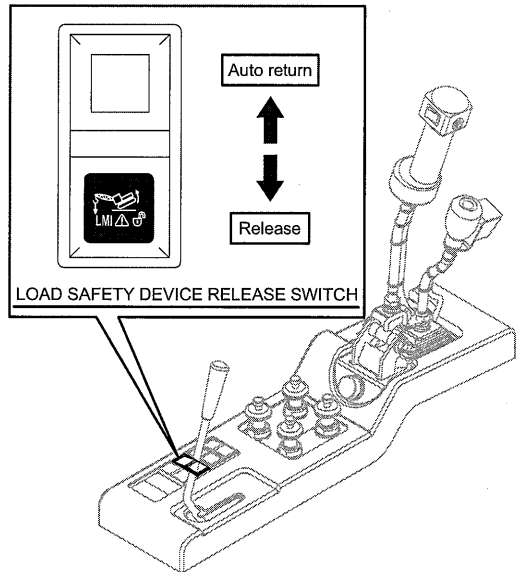

6. BOOM/JIB OVERHOIST RELEASE SWITCH

If the boom/jib lifting work has to be continued after the boom/jib overhoist device stops the operation by some reason, this switch release the auto stop function.

- **Release**

Only during the time when this switch is turned to release side, auto stop function of the boom/jib over hoist device can be released.

The switch can automatically return when the switch is hand released.

This switch is functional only when "45. RELEASE SWITCH MASTER KEY" is turned to release side.

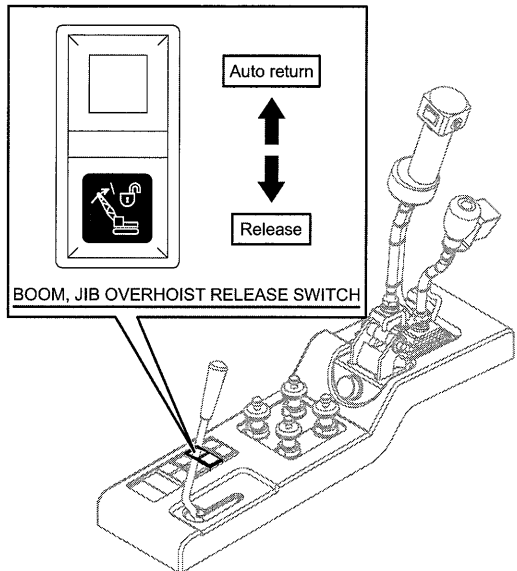

7. HOOK OVERHOIST RELEASE SWITCH

If the hook has to be continued lifting after the hook over-hoist preventive device stops the operation by some reason, this switch release the auto stop function.

- **Release**

Only during the time when this switch is turned to release side, auto stop function of the hook over-preventive device can be released.

The switch can automatically return when the switch is hand released.

This switch is functional only when "45. RELEASE SWITCH MASTER KEY" is turned to release side.

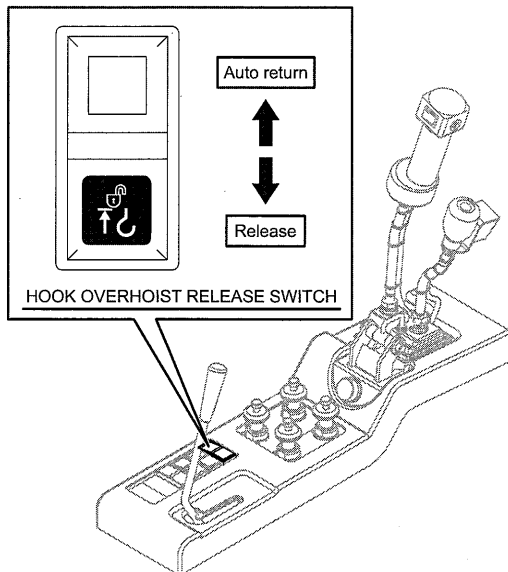

2

8. GANTRY CONTROL SWITCH

This switch is to control the gantry raising or lowering motion.

- **Raise** : The gantry rises up.
- **Lower** : The gantry lowers.
- **Neutral** : The gantry is held.

Switch returns automatically when hand is released.

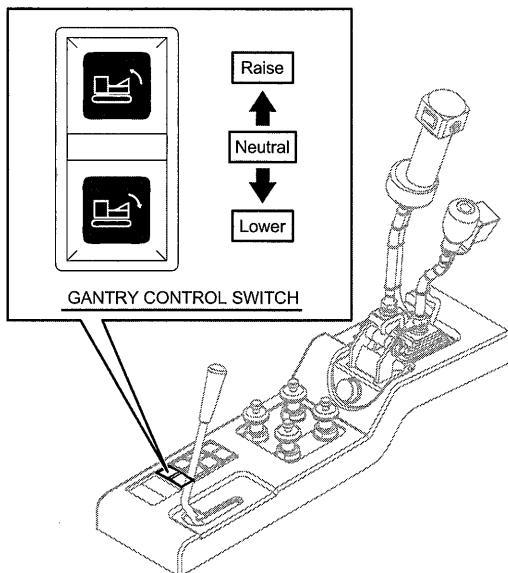

CAUTION

When the gantry is raised or lowered, make sure that there is no persons around the gantry area and observe the raising or lowering condition of the gantry.

SWING CONTROL LEVER

9. SWING BRAKE SWITCH

This is a brake to hold the upper machinery stationary and not to swing.

- **Engage** : Swing brake is engaged.
- **Disengage** : Swing brake is disengaged.

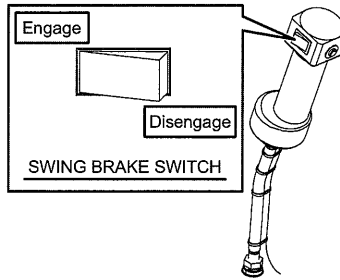

SWING CONTROL LEVER

CAUTION

Do not use the swing brake to stop the upper machinery during swing motion.

This would cause large burden to the boom and swing unit and is very dangerous.

Apply the swing brake after the upper machinery is completely stopped.

Due to the wind or ground slope main machinery may start swing unexpectedly.

Take extra care when disengaging the swing brake.

If the engine is started with the swing brake disengaged or if the function lock lever is turned to lock position with the swing brake disengaged, the swing brake is kept engaged.

In such case, turn the swing brake to "ENGAGE" side once and then turn to "DISENGAGE" side.

Failure to observe this precaution may result in a serious injuries or loss of life.

10. HORN SWITCH

This switch issues horn sound at the engine start or swing to alarm for personnel. While the switch is being pushed, the horn sounds.

The switch returns to neutral when hand is released.

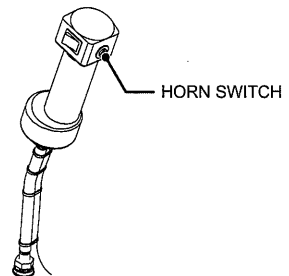

SWING CONTROL LEVER

OTHERS

11. KEY SWITCH

This switch is to start, stop the engine and connect its accessory circuit.

- **OFF :**
Engine shut off position.
(Key insert position. Take out position.)
- **ACC :**
Accessory ON position.
- **ON :**
Engine running position.
- **START :**
Engine start position.

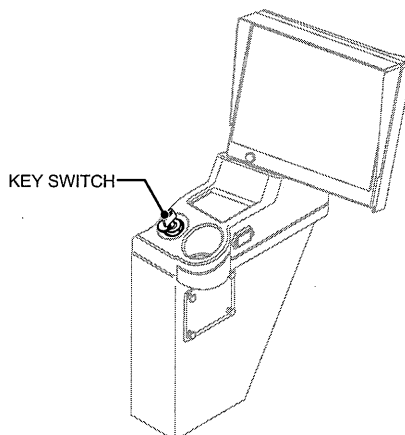

2

Note

There is no glow preheat switch but engine control unit (ECU) automatically preheat as required. During preheating, the monitor in the operator cab indicates  icon.

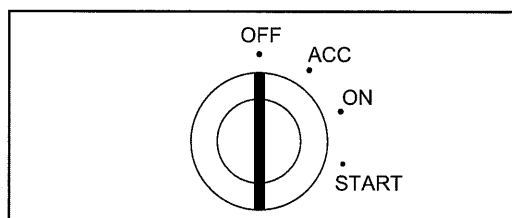

CAUTION

When starting the engine, make sure that the function lock lever is in lock position and each control lever is in neutral position.

12. CIGARETTE LIGHTER

When pushed in, lighter is held at its position and when heated red, it is popped out. Pull out for use.

CAUTION

If the lighter knob does not pop up within 30 seconds after it is pushed in, pull it out.

If keep pushed in, wiring may be damaged and may cause fire.

CIGARETTE LIGHTER

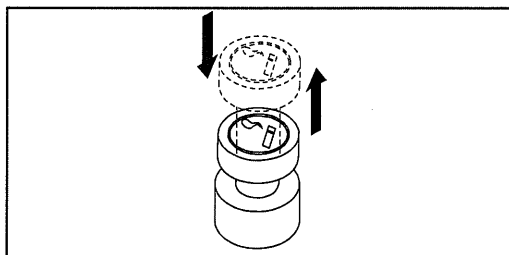
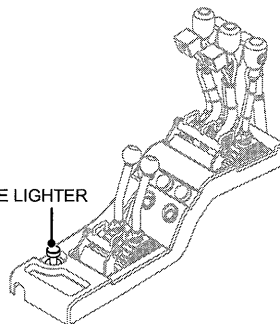

13. ENGINE ABNORMAL DETECT LAMP

This lamp lights up when the engine control unit (ECU) detects engine abnormal.

Normally (in case of no abnormal) it lights up when the engine stops but goes out when engine starts.

ENGINE ABNORMAL
DETECT LAMP

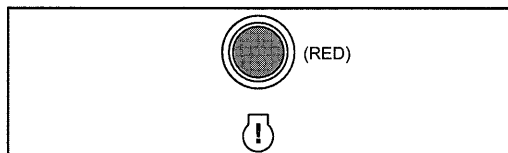
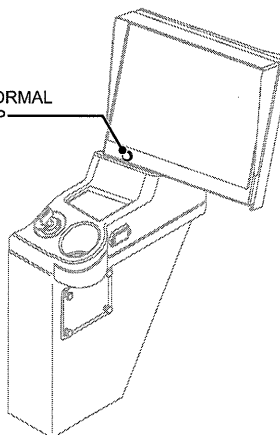

HOIST CONTROL LEVER

- 14. FRONT DRUM BRAKE SELECT SWITCH**
- 15. REAR DRUM BRAKE SELECT SWITCH**
- 16. THIRD DRUM BRAKE SELECT SWITCH (OPTION)**

These switches are to select the required mode in the free fall or neutral brake.

As for the detail of free fall operation, refer to the article "2.4 FREE FALL OPERATION (OPTION)".

- (1) Free fall mode

Turns the free fall lock switch to release side and push the switch while pressing the brake pedal fully will make free fall mode.

At the same time, free fall indication lamp lights up to advise free fall mode. (Brake turns into brake pedal control.)

- (2) Neutral brake mode

Pushing the switch again while pressing the brake pedal fully turns into the neutral brake mode.

At the same time free fall indicating lamp goes off. (Brake turns into auto brake.)

For safety it certainly turns to neutral brake mode immediately after the engine start.

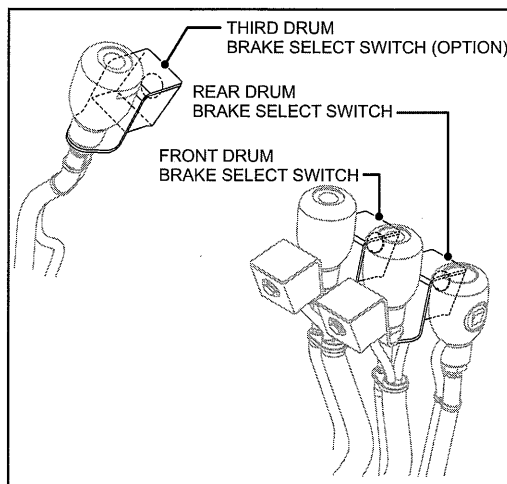

2

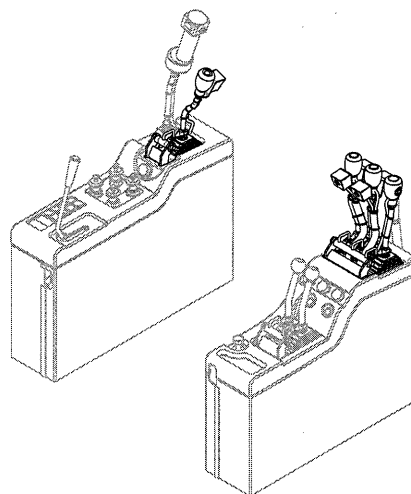

- 17. FRONT DRUM G WINCH SWITCH**
- 18. REAR DRUM G WINCH SWITCH**

By turning "40. G WINCH MAIN SWITCH" ON and pushing this switch makes maximum speed raising or lowering of each winch possible.

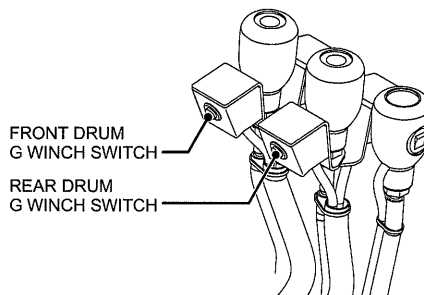

19. INCHING SPEED SWITCH

This switch is to make each motion speed of front drum, rear drum, boom drum and propel to inching speed. (Inching operation)

- **Inching speed :**
Motion speed of the front drum, rear drum, boom drum and propel becomes 1/4 of the normal speed.
- **Normal speed :**
This is the normal motion speed.

Selection of swing speed is done with swing mode select switch.

INCHING SPEED SWITCH

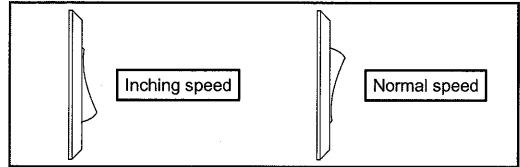
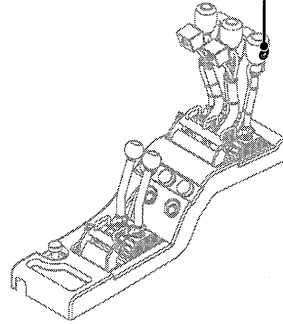

- 20. FRONT DRUM SPEED ADJUST TRIMMER
- 21. REAR DRUM SPEED ADJUST TRIMMER
- 22. THIRD DRUM SPEED ADJUST TRIMMER (OPTION)
- 23. BOOM DRUM SPEED ADJUST TRIMMER

This trimmer adjusts the drum speed separately to the drum speed control by the control lever. (This makes synchronous speed adjusting with other drum possible.)

- **High (right turn) :**
Drum speed is increased.
- **Low (left turn) :**
Drum speed is decreased.

THIRD DRUM SPEED CONTROL TRIMMER (OPTION)

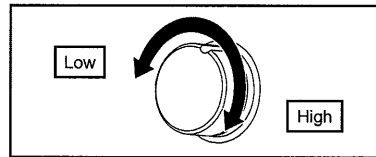
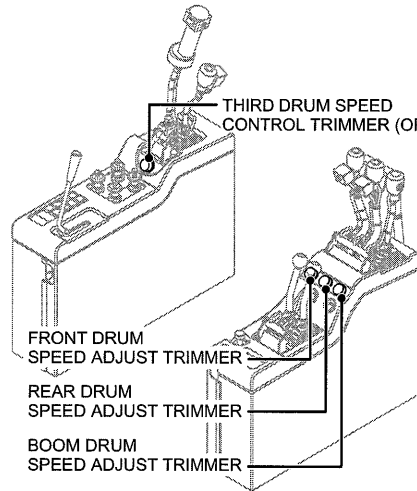

LEFT SIDE SWITCH PANEL

24. WIPER SWITCH (FRONT WINDOW)

25. WIPER SWITCH (SKY LIGHT)

	Continuous operation
INT	Intermittent operation

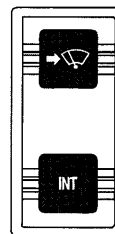

Continuous



Intermittent

2

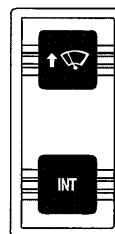



Continuous



Intermittent

26. WASHER (SKYLIGHT, FRONT WINDOW)

	Washer liquid comes out to sky light.
	Washer liquid comes out to front window.

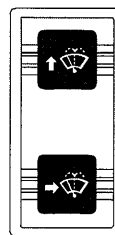

Sky light



Front window

Note

Check the fluid level periodically and refill if required.

Refer to the article 7 "UPPER LUBRICATION (INCL. WATER SUPPLY)" for the location of the washer tank.

- 27. FRONT DRUM FREE FALL SPEED SELECT SWITCH
- 28. REAR DRUM FREE FALL SPEED SELECT SWITCH
- 29. THIRD DRUM FREE FALL SPEED SELECT SWITCH (OPTION)

In order to make free fall of the hook or load effective while the temperature is low, free fall speed can be selected on each drum.

After "53. HYDRAULIC OIL HEAT CIRCUIT SELECT ICON (OPTION)" is turned to ON, and when the hyd. oil temperature becomes warm, turn the speed select switch to "speed increase".

Lowering characteristics of free fall is improved.

- **Speed increase :**
Free fall speed is increased.
This is suitable for light weight free falling work when ambient temperature is low at winter time.
- **Normal :**
Free fall speed is normal.
This is suitable for normal load free fall work.

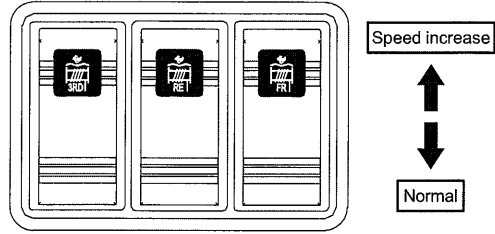

CAUTION

Do not use this switch when the heavy weight free fall work is being done.

Do not release the brake pedal when the hook is grounded with SPEED INCREASE.

The drum rotates automatically to lowering direction and the drum wire rope would be rough-spoiled.

30. ENGINE EMERGENCY STOP SWITCH

Push this switch to stop the engine in emergency. The switch is held at the pushed position.

Turn the switch to right to return to the original position.

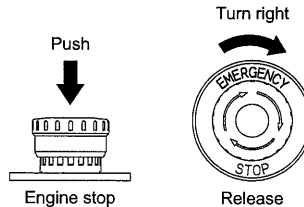

Note

The engine will not start when the switch is being pushed in.

31. TAGLINE TENSION ADJUST TRIMMER (OPTION)

This trimmer is to adjust the tagline rope tension.

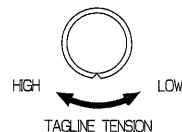

- **High (right turn) :**
Tagline rope tension becomes high.
- **Low (left turn) :**
Tagline rope tension becomes low.

When the tagline is not in use, set the trimmer to "LOW" side.

The drum speed adjustment can not be done with the adjusting trimmer.

32. WORK LIGHT SWITCH

33. REAR WORK LIGHT SWITCH (OPTION)

- **ON :** Light becomes ON.
- **OFF :** Light becomes OFF.

CAUTION

Ensure to turn the work light switch "OFF" when the work is completed.

Failure to turn the switch off may cause battery discharged.

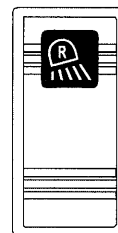
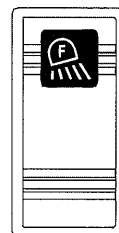

34. DRUM LIGHT SWITCH (OPTION)

This switch is for drum rope winding condition checking light.

- **ON :** The light is ON.
- **OFF :** The light is OFF.

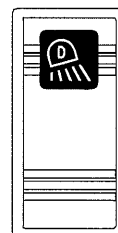

35. AUXILIARY ACCEL SWITCH

This switch is used when engine speed adjustment can not be done due to failure of accel grip.

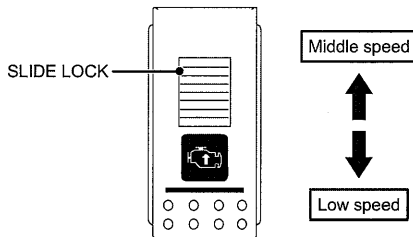

- **Middle speed :**
Engine speed becomes approx. 1,500 min⁻¹ (1,500 rpm).
- **Low speed :**
Engine speed becomes approx. 800 min⁻¹ (800 rpm).

CAUTION

Do not use the auxiliary accel switch when the accel grip is normal.

- * This switch is equipped with the slide lock.
This switch can be operated only when the slide lock is slid to upper side.

36. EMERGENCY STOP CHECK SWITCH

This switch can check the auto-stop function of the boom and jib.

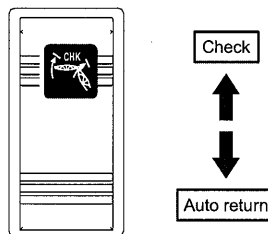

- **Check :**
Check of the auto-stop function can be done.
Raising or lowering of the boom, raising of the jib or lowering of the hook can not be done.

Switch returns automatically when hand is freed.



37. SWING ALARM SELECT SWITCH

This switch is to select swing alarm.

 (Alarm light buzzer)	Buzzer sounds and swing flasher goes ON and OFF.
 (Alarm)	Swing flasher goes ON and OFF.
OFF	Nothing occurs.

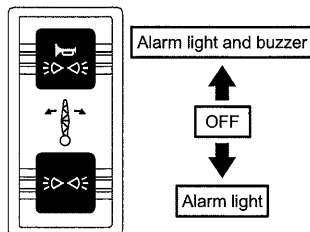

RIGHT SIDE SWITCH PANEL**38. AUX. ACTUATOR SELECT SWITCH**

- **ON :**
Reeving winch (option) control can be done.
- **OFF :**
Gantry, tagline (option) control can be done.

Normally use OFF position.

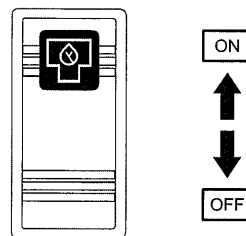

2

39. PROPEL SPEED SELECT SWITCH

- **High speed :**
Propel speed is fast.
- **Low speed :**
Propel speed is slow.

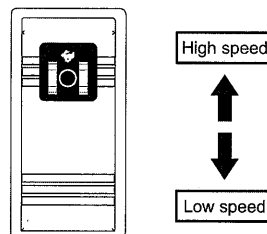
**⚠ CAUTION**

Do not change the switch during propelling. It may cause deflected propel.

REAR SWITCH PANEL

40. G WINCH MAIN SWITCH

This is the main switch to use G winch.
G winch is a function to realize maximum line speed with low engine speed at no load condition.

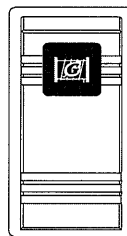

ON



OFF

41. AUTO IDLE STOP SWITCH

- **ON :**
Auto idle stop function becomes effective.
When auto idle stop conditions are filled, countdown is indicated on the monitor and engine stops at count zero.
- **OFF :**
Auto idle function becomes ineffective.
Even when other auto idle stop conditions are filled, count down does not start.

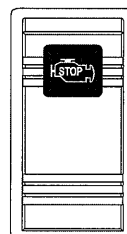

ON



OFF

42. G ENGINE SWITCH

G ENGINE is a function to obtain maximum line speed under no load with maximum engine speed being restricted.

- **ON : G ENGINE**
Max. engine speed becomes approx. 1,725 min⁻¹ (1,725 rpm) and G ENGINE operation becomes possible.
But in case of heavy load lifting, lifting speed becomes lower than power mode.
- **OFF : POWER MODE**
Max. engine speed becomes approx. 2,100 min⁻¹ (2,100 rpm) and lifting speed decrease is smaller than G ENGINE and is suitable for heavy load lifting.

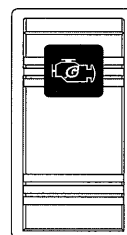

ON



OFF

43. PROPEL ALARM SWITCH (OPTION)

This is to select the propel alarm.

- **ON : Buzzer voice alarm is issued.**
- **OFF : Nothing occurs.**

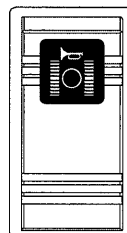

ON



OFF

44. FRONT / REAR DRUM ROTATION INDICATOR SWITCH

This select switch is to select the grip for sensing the drum start and rotating condition.

- **ON :**
The grip top movable point moves based on drum speed.
- **OFF :**
Nothing occurs.

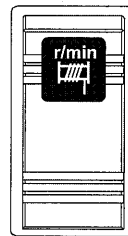

2

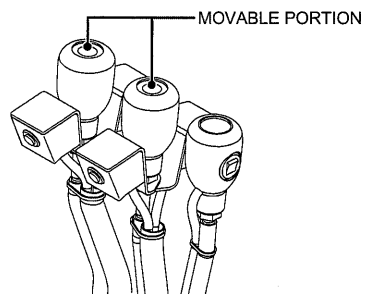

BYPASS SWITCH PANEL

45. RELEASE SWITCH MASTER KEY

This is the master key to lock releasing the load safety device, boom over-hoist and hook over-hoist for safety.

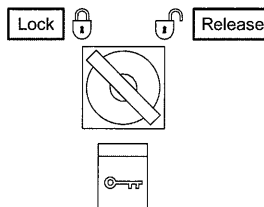

- **Lock**

Release of the auto-stop functions of the load safety device, boom over-hoist and hook over-hoist can not be done.

- **Release**

When the key is turned to release side, the auto-stop function of the load safety device, boom over-hoist and hook over-hoist become possible.

The key can be pulled out at "LOCK" side.



During work, the key must be kept and be controlled by work responsible person.

46. FREE FALL LOCK SWITCH

This is the master key to lock the free fall operation during the work or at the place where the free fall is prohibited for safety.

- **Lock**

Free fall of the front, rear and third drum becomes impossible.

- **Release**

When the key is turned to "RELEASE" side, free fall of the front, rear and third drum becomes possible.

When the switch is in "LOCK" side, free fall can not be done even when the brake select switch is turned to "FREE FALL" side.

The key can be pulled out at the "LOCK" position.

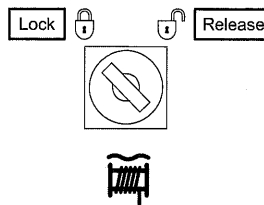

2

CAUTION

During work the key must be kept and be controlled by work responsible person.

47. MAIN CONTROLLER 1 BYPASS SWITCH**48. MAIN CONTROLLER 2 BYPASS SWITCH**

- **MAIN CONTROLLER 1 BYPASS SWITCH**

When the main controller 1 failed, swing control becomes possible.

- **MAIN CONTROLLER 2 BYPASS SWITCH**

When the main controller 2 failed, each of front drum, rear drum, third drum and boom hoist control becomes possible.

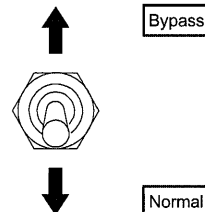

CAUTION

Do not use these switches for other than emergency evacuation work due to failure of controller.

ICON IN THE MONITOR

- 49. **SWING MODE SELECT ICON (FREE/HIGH SPEED)**
- 50. **SWING MODE SELECT ICON (FREE/LOW SPEED)**
- 51. **SWING MODE SELECT ICON (BRAKE/LOW SPEED)**

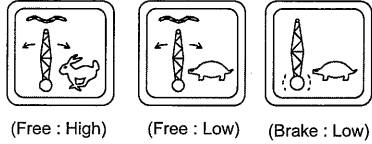

This icon is to select the swing control and swing speed based on work contents.
 This icon is displayed on the monitor and touching it can select the swing mode.
 The selected mode icon is displayed in green.

* Push for more than 1 second.

FREE/HIGH SPEED, FREE/LOW SPEED

With the lever neutral mode becomes swing free.
 Select the swing speed based on the work.

BRAKE/LOW SPEED

With the lever neutral, swing brake is engaged.
 (Hydraulic brake)

- **Each mode and its work content**
 - (1) Free/high speed
Crane, lifting magnet and clamshell work.
 - (2) Free/low speed
Long boom crane work.
 - (3) Brake/low speed
Long boom crane work.

At the long boom crane work, if the select icon is kept to brake/low speed side, operation is easy but hydraulic control is being applied to reduce swing stop shock and swing power is lowered and swing speed becomes slow.

LOW SPEED

At high idling about 50% of high speed.
 At low idling about 70% of high speed.



Mode change must be done when the swing brake switch on the accel grip to ENGAGE and the engine speed is low.

Never change the mode during swing operation.

52. CAMERA SELECT ICON (OPTION)

This icon is to select camera indication/non indication or to select camera when multiple cameras are indicated.

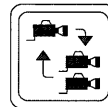

- * Press for more than 1 second.

53. HYDRAULIC OIL HEAT CIRCUIT SELECT ICON (OPTION)

This select icon is to make free fall of the hook or load effective by heating up the hyd. oil while the temperature is low.

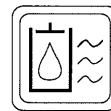

- * Press for more than 1 second.

- **ON :**

The device to heat up the hydraulic oil is actuated.

Even with the icon ON, when the hyd. oil temperature becomes about 50°C (122°F) the device becomes OFF and ON when cooled down to 40°C (104°F).

Use this icon at winter time or morning time.

The icon turns to green when turned ON.

- **OFF :**

The heating device does not work.

Note

This device heats up the hydraulic oil tank by relieving the portion of hydraulic oil.

54. WORK MODE SELECT ICON

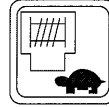

This select icon is to perform the work smoothly based on work content.

- * Press for more than 1 second.
- **High speed :**
Normal work
(Auto variable position)
- **Low speed :**
Special work
(Front and rear drum are low speed fixed position)
The icon turns to green when low speed is selected.

Select "LOW SPEED" when synchronization of front and rear drum speed is difficult for heavy load such as clamshell.

- * Press for more than 1 second.

55. INDEPENDENCE / CONFLUENCE ICON (OPTION)

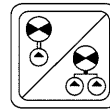

- **ON : Confluence mode**
This is the suitable mode for heavy work such as bucket work or clamshell work.
- **OFF : Independence mode**
This is the mode which has less operation interference when the front drum, the rear drum and the boom hoist drum are operating.
This is suitable for fine control operation.

- * Push for more than 1 second.

56. MENU ICON



This icon is used to indicate select item list.

57. SOOT BURNING (REGENERATE) ICON

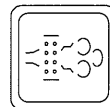

This icon is used to burn accumulated soot in the muffler filter.

- * Press for more than 1 second.

58. DIMMER ICON

This icon is used to change the display brightness.

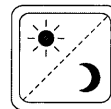

- * Press for more than 1 second.

59. BOOM / JIB LOWERING ICON

This icon is used to lower the boom or jib to the area out of the work area.

This icon becomes indicated only when the boom, jib stops at the low limit angle.



- * Press for more than 1 second.

60. ASSY/DISASSY ICON

This icon is used to select assy/disassy mode or work mode.

This icon becomes indicated when the mode select becomes possible.

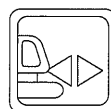

- * Press for more than 1 second.

61. G ENGINE INDICATING LAMP

This lamp lights up when G ENGINE is selected.
(When "42. G ENGINE SWITCH" is turned ON.)

**62. G WINCH INDICATING LAMP**

These lamps on both sides turn ON to yellow when "40. G WINCH MAIN SWITCH" is turned ON.

When front drum side is set to G winch mode, left side changes from yellow to green.

When rear drum side is set to G winch mode, right side changes from yellow to green.

**63. AUTO IDLE STOP WORK LAMP**

This lamp lights up when engine is topped due to auto idle stop function.

Refer to "2.3.4 AUTO IDLE STOP FUNCTION".



64. CONFLUENCE LAMP (OPTION)

This lamp lights up when the confluence circuit is selected.

(When "55. INDEPENDENCE / CONFLUENCE ICON (OPTION)" is turned ON)



65. FRONT DRUM FREE FALL INDICATION LAMP

66. REAR DRUM FREE FALL INDICATION LAMP

67. THIRD DRUM FREE FALL INDICATION LAMP (OPTION)

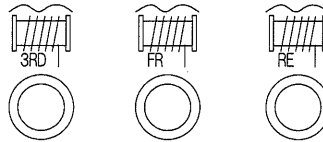

This lamp lights up when drum becomes free fall mode.

68. INCHING SPEED LAMP

This lamp lights up when "19. INCHING SPEED SWITCH" is turned to "Inching speed" side.

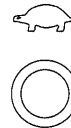

69. ELECTRIC OIL COOLER WORK INDICATING LAMP

This lamp lights up when the electric oil cooler is working.



70. BATTERY LAMP (OPTION)

This lamp indicates the level of auto-idling stop possible or not based on battery charging condition.



Green :

Auto-idle stop possible

Yellow :

Auto-idle stop possible (for short time)

Red :

Auto-idle stop not possible

71. REMOTE CONTROL CONNECTION LAMP

This lamp lights up when the remote control box for translifter is connected to the main machinery.



72. HYD. OIL TEMP. GAUGE

This indicates hydraulic oil temperature.

Scale is divided by 5°C (41°F) pitch.

The highest division indicates higher than 115°C (239°F) and the lowest division indicates lower than 50°C (122°F).

The gauge color change from white to red at higher than 80°C (176°F).

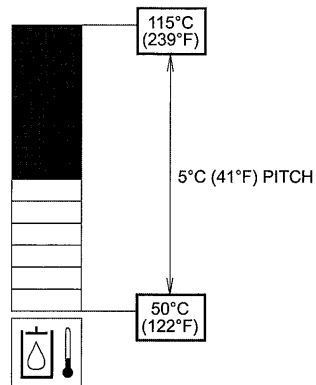

2

73. FUEL GAUGE

This indicates fuel level. Scale is divided into 15.

The highest division indicates 355 ltr. (93.7 gal) and the lowest division indicates less than 44 ltr. (11.6 gal).

The gauge color changes from white to red at lowest two blocks.

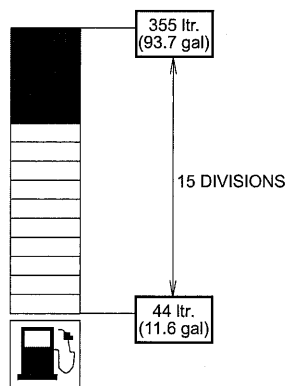
**74. SOOT ACCUMULATION GAUGE**

This gauge indicates guide post of soot accumulated in the diesel particulate filter.

The gauge color changes from white to yellow at higher than 3 blocks, from yellow to orange at higher than 5 blocks and to red at 10 blocks.



75. ENGINE COOLANT TEMP. GAUGE

This indicates engine cooling water temperature. Scale is divided by 5°C (41°F) pitch.

The highest division indicates higher than 115°C (239°F) and the lowest division indicates lower than 70°C (158°F).

The gauge color changes from white to red at higher than 105°C (221°F).

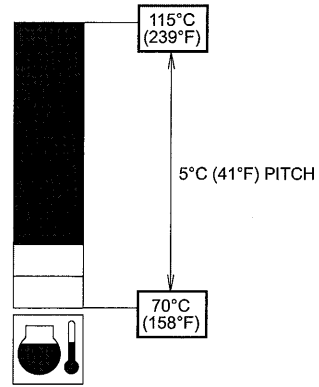

2.2.3 VARIOUS SETTING OF MONITOR

Screen setting, option setting etc are possible.

Press  icon.

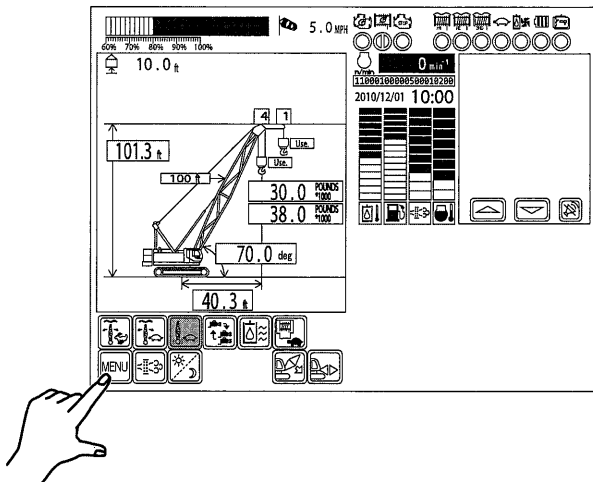

Press  in the indicated menu.

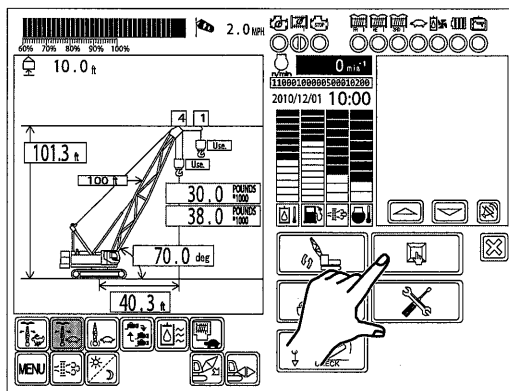

List of setting items are indicated.

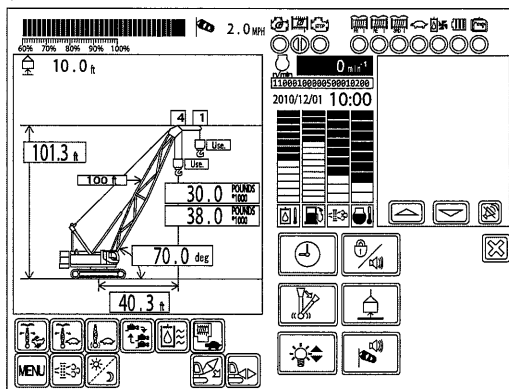

1. Time setting

(1) Press  in the indicated menu.

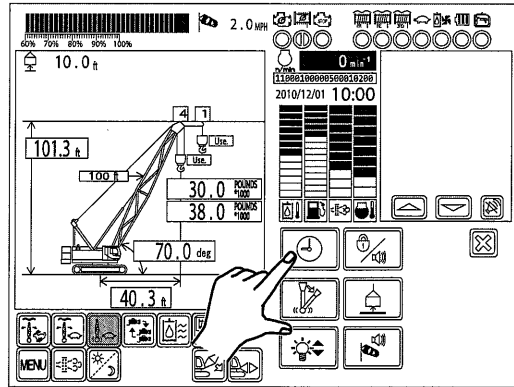

(2) Current set year, month, day, time and minute are indicated.
Press the item required to change.

(A) Pressed item is highlighted.

(B) Under this condition, input numbers with the right side number pad.
If there is other area to change, input numbers with the same procedure.

(C) After input, press .

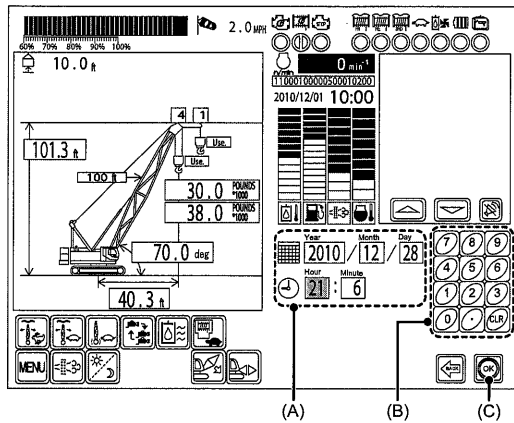

(3) This is to complete setting.

2. Setting of lever detent force (holding force)



Set the mid point detent force (1st speed detent).

Set the detent force based on requirement.

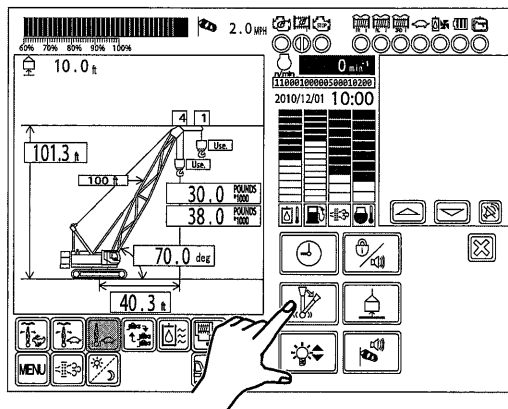
(1) Press  in the menu.



2

(2) Change the number with  or .

Number can be changed between 0 and 150.
The detent force becomes larger as number becomes higher.

(A) Setting of front drum.

- Press (a)

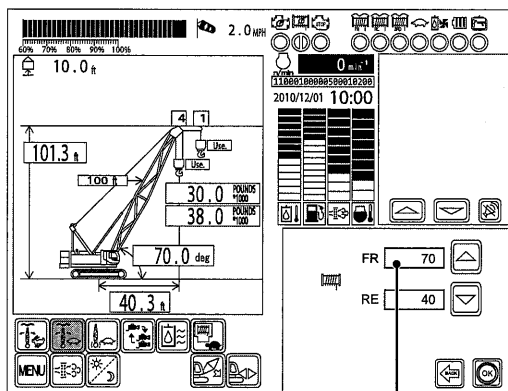

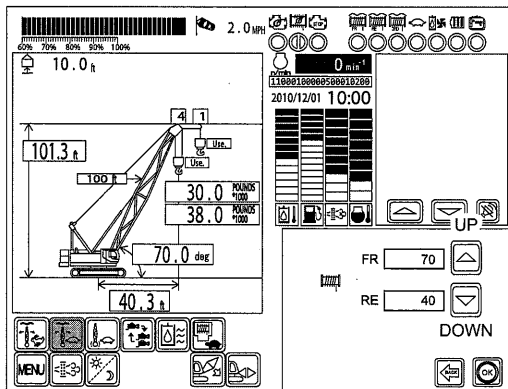

(a)

- Change the number with  or .



(B) Setting of rear drum.

- Press (b).
- Change the number with  or .
- When changing number is completed, press .

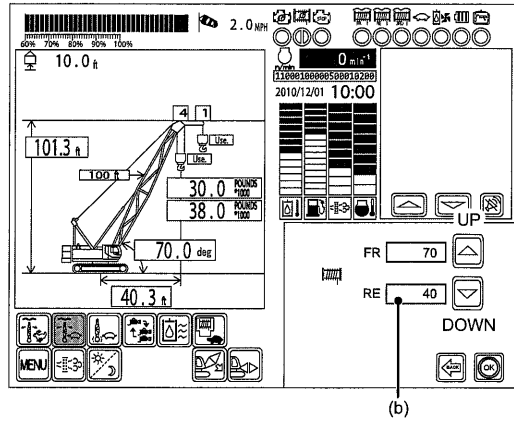

3. Setting of wind speed warning (option)

In case of wind speed sensor is equipped, set the wind speed data to issue warning.

- (1) Press  in the menu.

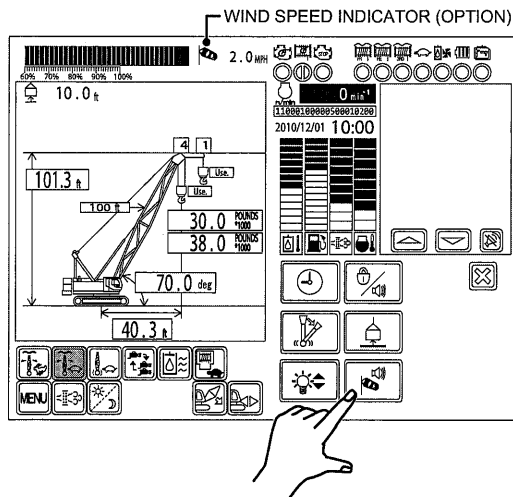

- (A) Pressed item is highlighted.
 (B) Under this condition, input numbers with the right side number pad.
 (C) After input, press .

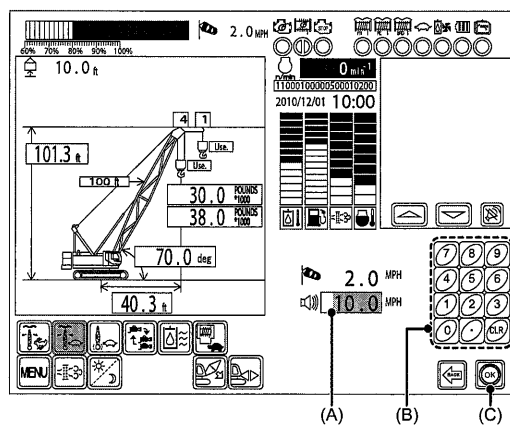

- (2) This is to complete setting.
 When the wind speed exceeds the set value, wind speed indication turns to red color and buzzer sound is issued.

4. Setting of drum rope layer

To use load height meter properly, adjustment of drum rope layer becomes required whenever the drum is turned idling for attachment assembly or disassembly.

If the adjustment is not enough, height indication would not vary or indicated value would become out of order.

Ensure to adjust.

Each adjustment is required on front drum and rear drum.

The same procedure is applied for both.

Front drum adjustment is explained here as an example.

- (1) Lift up or lower the main hook and stop the hook when the wire rope changes its layer
- (2) Press  in the menu.

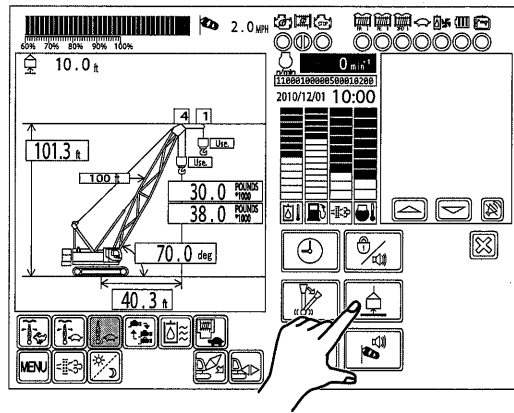

- (A) Pressing the number portion on FR (front drum) side makes it highlighted.
- (B) Under this condition, input numbers with the right side number pad.
In case of border between 4th or 5th layer For example, input "5".
- (C) After input, press .

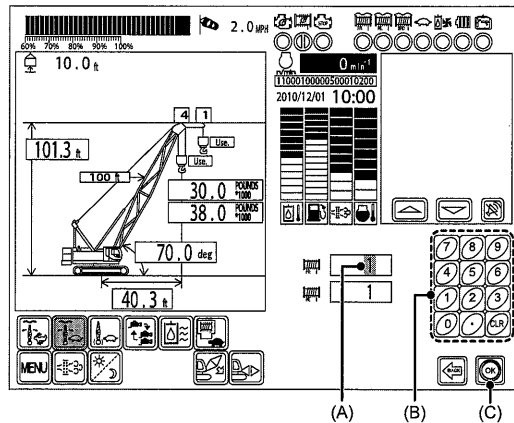

- Layer number can be checked by measuring distance from drum flange step and the wire rope.

Refer to the figure below.

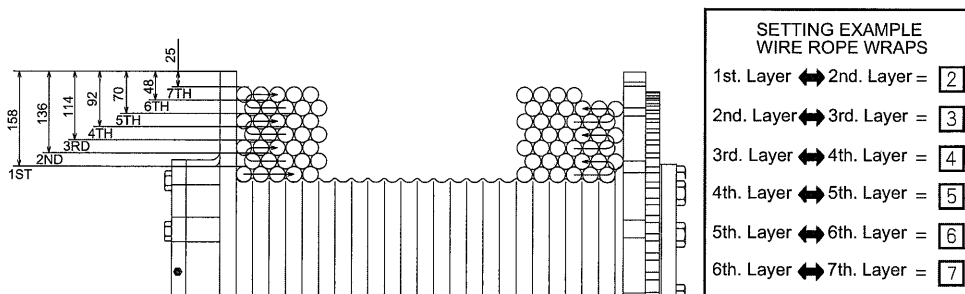

- (3) This is to complete the setting.

“6. Handling of the height meter” check to see that the height indication varies as per setting following the handling method of the height meter.

If there is any abnormality in height indication, the sensor gap adjustment may not be correct.

Perform the gap adjustment of the proximity sensor.

If abnormality still exists, receive the inspection by KOBELCO service shop.

5. Brightness setting of LCD

Adjust the monitor brightness.

- (1) Press  in the menu.

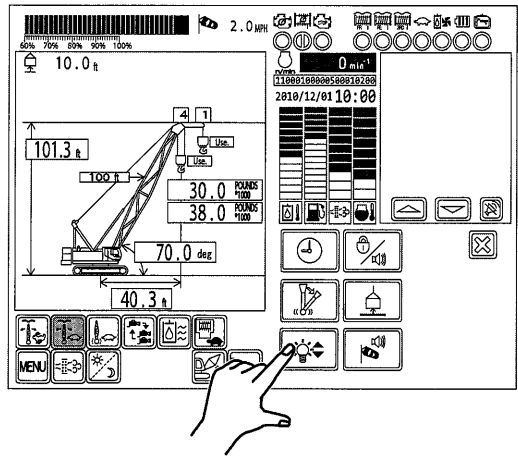

- (2) 8 step adjustment is possible.

- (A) By pressing the bar area, brightness varies.
The brightness becomes higher as bar goes toward right (longer bar).
- (B) When the desired brightness is selected, press .

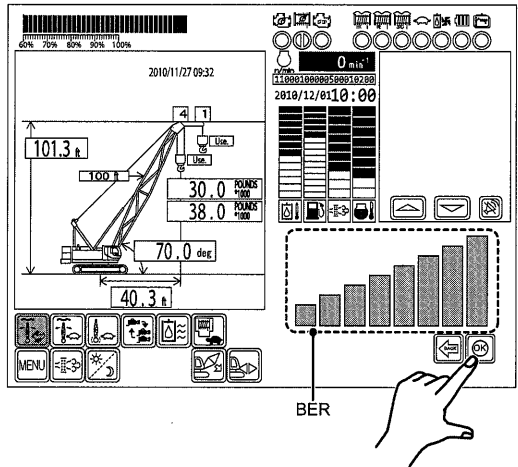

- (3) This is to complete the setting.

6. Handling of the height meter

- (1) Select the hook to be used.
Press the figure area of the hook to be used.
Selected hook is indicated dark and non selected hook is indicated light.
- (2) Check to see that the indicated number of part line of the hoist rope matches with actual condition.
- (3) Move the hook to a certain height and press the height indicating area.
Height value is rest and "0.0 m" is indicated.
- (4) If height with winch raising, lowering, boom or jib raising/lowering is higher than zero rest height, plus indication appears and minus indication appears when lower.

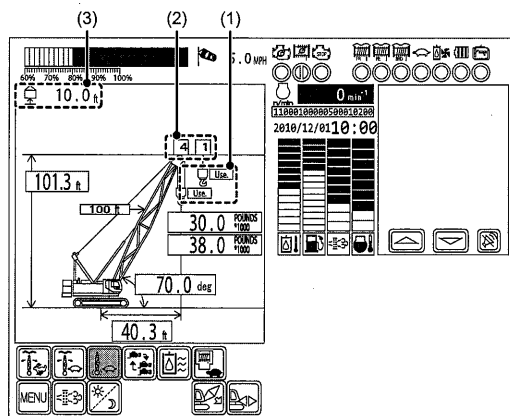

7. Handling of the bypass switch when touch panel of the monitor dose not functioning

In case of abnormal phenomenon occurs on the monitor as no functioning of touch panel at the boot up, the crane operation becomes possible by the following bypass processing.

- (1) Remove a fuse F17 (5A) for not applying the power to the monitor.
- (2) Start the engine.
- (3) The main controller 2 bypass switch is to be turned ON once and immediately after turned OFF.
- (4) Confirm each levers are ready for operation after the function lock lever is shifted to work side.
- (5) If not obtain the crane operation after the step (4) above has been carried out, repeat step (3) again and reconfirm of the readiness for operation.

⚠ CAUTION

This process is to be made only at emergency case.

No any indication on the display panel.

Evacuate from the situation carefully.

Contact to the authorized KOBELCO distributor as soon as evacuation has been made.

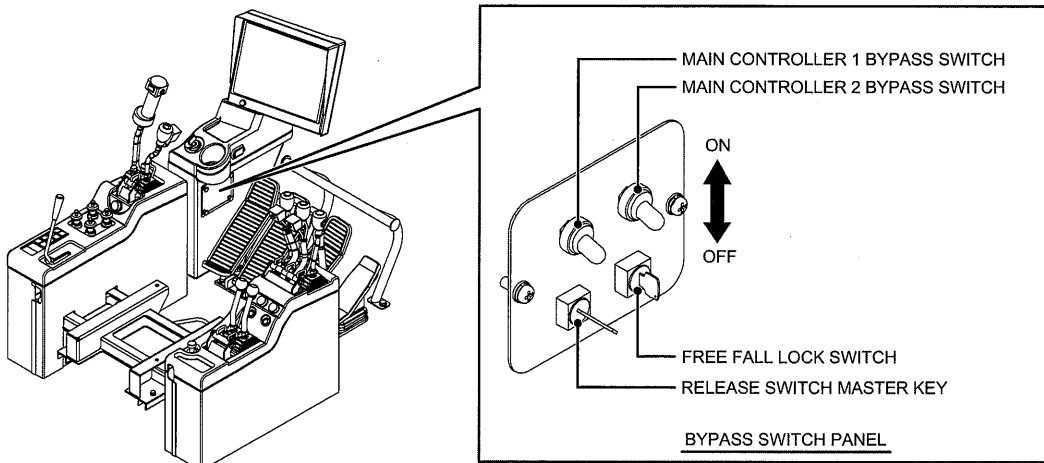

2.2.4 WIND SPEED SENSOR INSTALLATION (OPTION)

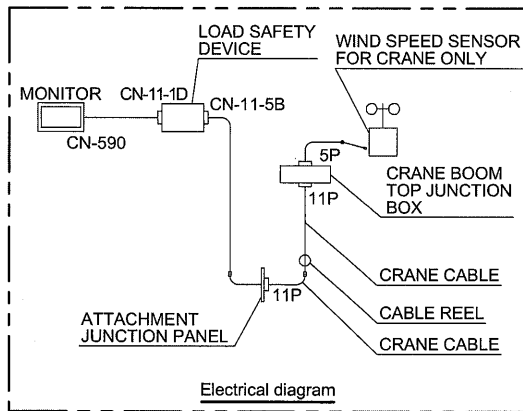
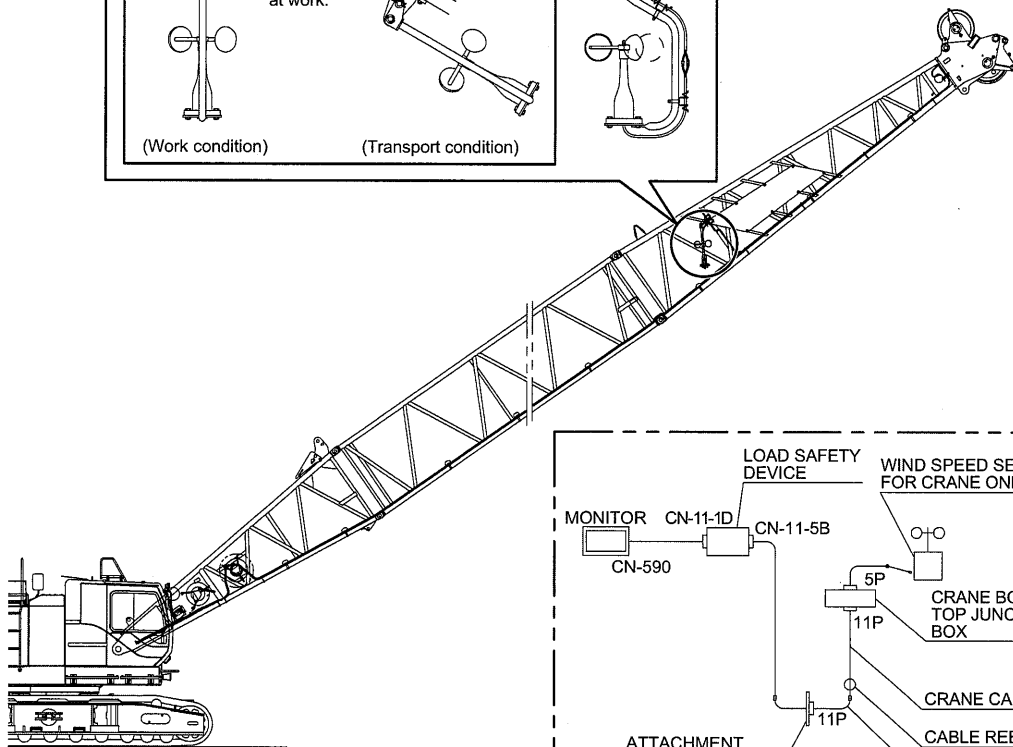
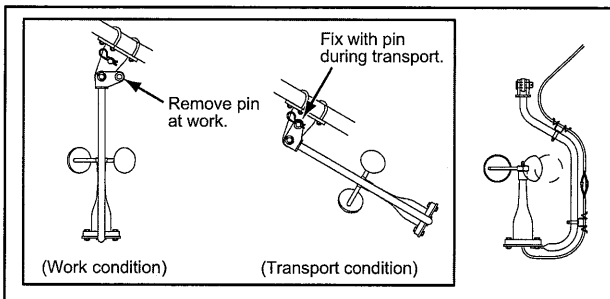

2.2.5 AIR CONDITIONER

NAME OF THE AIR CONDITIONER PARTS

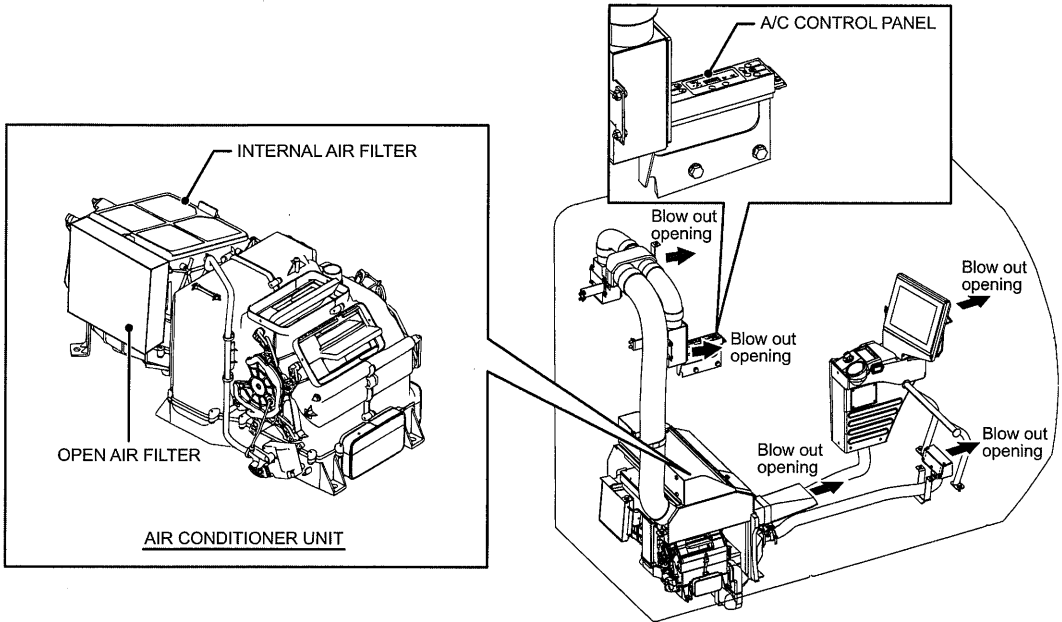

NAME OF THE CONTROL PANEL

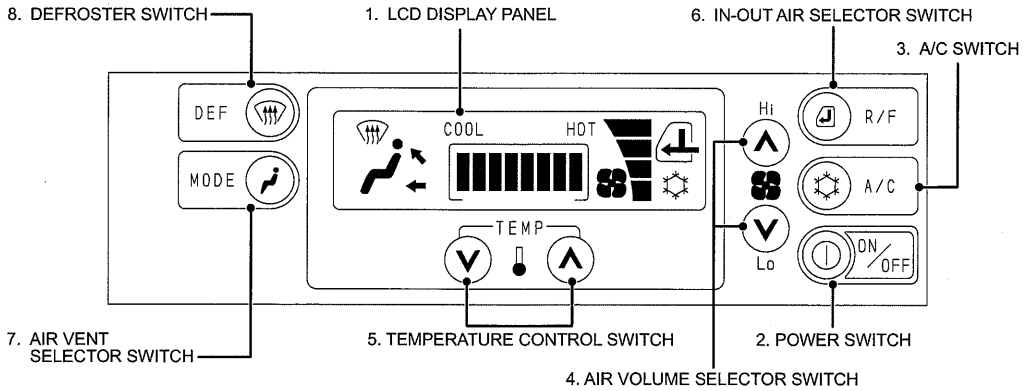

FUNCTION OF EACH CONTROL

1. LCD DISPLAY PANEL

Air volume setting etc. is displayed.

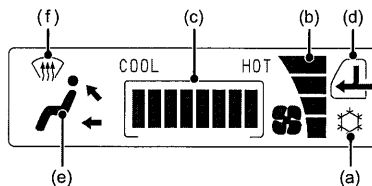

2. POWER SWITCH (ON/OFF SWITCH)

It turns ON or OFF the air conditioner.

When this switch is pushed at the first time, the air conditioner starts on factory set mode.

When this switch is pushed, air conditioner starts with previous set mode.



3. A/C SWITCH (AIR CONDITIONER SWITCH)

Every time when this switch is pushed, the air compressor alternates ON/OFF.

When the air conditioner is ON, ⚙️ lights up on the LCD display (a).

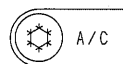

4. AIR VOLUME SELECTOR SWITCH (FAN SWITCH)

Air volume can be changed by pushing this switch when air conditioner is running.



⬆️	Increase air volume.
⬇️	Decrease air volume.

Set air volume is displayed on the LCD display (b)

LCD display				
Air volume	Low	Medium	High	Max. high

**5. TEMPERATURE CONTROL SWITCH
(AIR CONDITIONER TEMP. SET)**

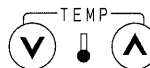

Pushing this switch changes temperature setting when the air conditioner is running.

	Rises temperature (blowing air temp.)
	Lowers temperature (blowing air temp.)

Set temperature is displayed on LCD display (c).



**6. IN-OUT AIR SELECTOR SWITCH
(R/F SWITCH)**



Every time when this switch is pushed, internal air / open air alternate.

Setting is displayed on LCD display (d).

	Internal air circulation
	Out air take in

**7. AIR VENT SELECTOR SWITCH
(MODE SWITCH)**



Every time when this switch is pushed, blow out opening changes on in sequence.

Setting is displayed on LCD display (e).

LCD display			
Blow out opening	Vent	Bi level	Foot
Blow out direction	Upper rear	Upper rear and foot	foot*

* Air blows from defroster also.

**8. DEFROSTER SWITCH
(DEF SWITCH)**



Every time when this switch is pushed, blow out opening changes to defroster.

is displayed on LCD display (f).

Blow out opening	Defroster
Blow out direction	Front windows*

* Air blows from foot also.





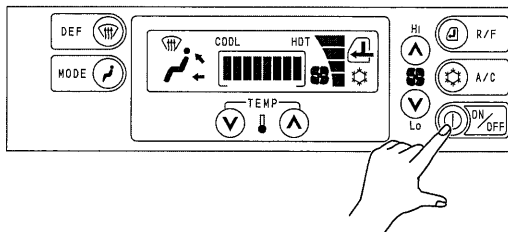

AIR CONDITIONER CONTROL

1. To start or stop air conditioner :

Push  (ON/OFF switch).







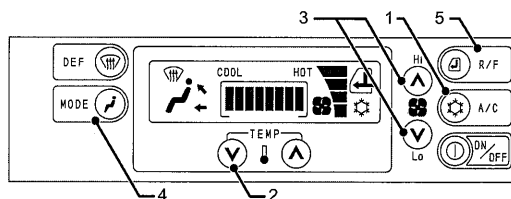

2. To cool :

- (1) Push  (A/C switch).
 - (2) Push  (Temperature control switch) to indicate  temperature display.
 - (3) Push the air volume selector switch for required air volume setting.
 - (4) Push  (Air vent selector switch) for  (Vent) position.
(Vent position is recommended in this case.)
 - (5) By pushing  (In-out air selector switch), set the selector to  (Internal air circulation).
(Recommended position in this case)
- If the A/C cools down too low, adjust the temp. or air volume by (2), (3).



-  (A/C switch) is not pushed, the A/C does not cool but only air flows.
- While defrosting the windows, do not set the temperature too low.
- Cold air may make windows foggy from outside and it may disturb the operator's view.





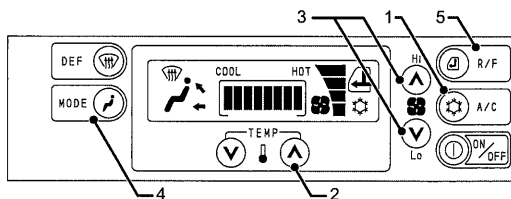

3. To warm :

- (1) Push  (A/C switch).
 - (2) Push  (Temperature control switch) to indicate  temperature display.
 - (3) Push the air volume selector switch for required air volume setting.
 - (4) Push  (Air vent selector switch) for  (Foot) position.
(Foot position is recommended in this case.)
 - (5) By pushing  (In-out air selector switch) set the selector to  (Internal air circulation).
(Recommended position in this case)
- If the A/C warms up too high, adjust the temp. or air volume by (2), (3).





- If  (A/C switch) is pushed, the A/C operates on dry air warming.
- If blow out opening is set to "FOOT", air bows from defroster also.



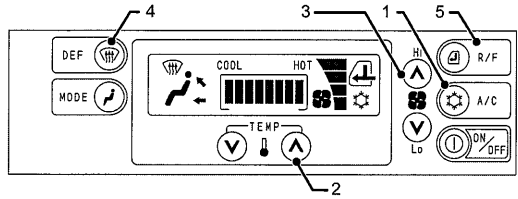

4. To defrost on the windows :

- (1) Push  (A/C switch).
- (2) Push  (Temperature control switch) to indicate  temperature display.
- (3) Push the air volume selector switch for "MAX, HIGH" air volume.
- (4) Push  (Defroster switch) to change the blow out opening to  (Defroster) position.
- (5) By pushing  (In-out air selector switch) set the selector to  (Internal air circulation).





- By pushing  (Air vent selector switch) blow out opening return to previous our before  (Defroster switch) is pushed.
- When blow out opening is set to "DEFROSTER", small amount of air comes out from foot also.

5. To defog on the windows :

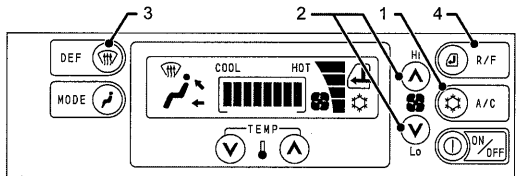
- (1) Push  (A/C switch).
- (2) Push the air volume selector switch for required air volume setting.
- (3) Push  (Defroster switch) to change the blow out opening to  (Defroster) position.
- (4) By pushing  (In-out air selector switch) set the selector to  (Air take in).



- If quick defogging is required, set the air volume to "MAX, HIGH" by (2).
- By pushing  (Air vent selector switch) blow out opening return to previous our before  (Defroster switch) is pushed.
- When blow out opening is set to "DEFROSTER", small amount of air comes out from foot also.

This page is blank for editing convenience.

2.2.6 AM/FM RADIO

SWITCH NAME

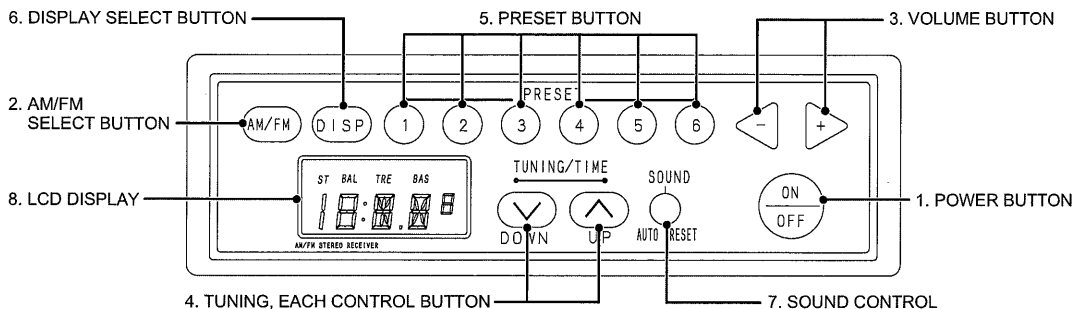

FUNCTION OF EACH AREA

1. POWER BUTTON

Turn radio ON/OFF.



2. AM/FM SELECT BUTTON

Select band.
(AM/FM1/FM2)



3. VOLUME BUTTON

Control volume.



4. TUNING, EACH CONTROL BUTTON

Select frequency, control step for sound control, adjust time.

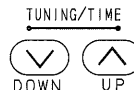

5. PRESET BUTTON

Call preset frequency and register.



6. DISPLAY SELECT BUTTON

Select display. (frequency/time)



7. SOUND CONTROL

Control sound. (balance/bass/treble)



8. LCD DISPLAY

Display frequency, clock.

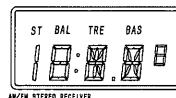

LCD DISPLAY

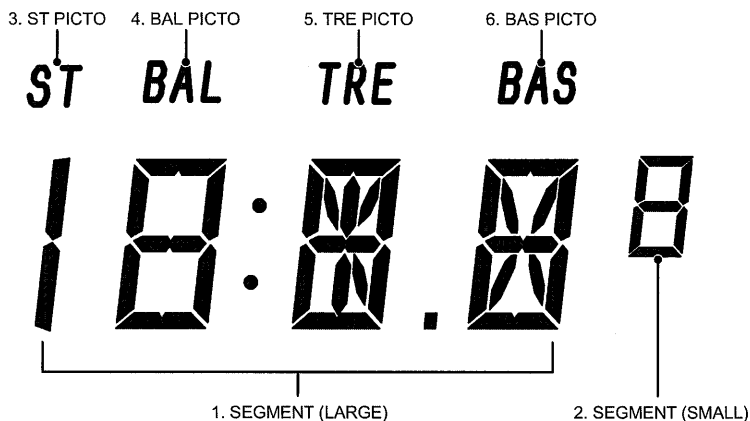

2

1. SEGMENT (LARGE)

To display band name, frequency, time, word/number.

**2. SEGMENT (SMALL)**

To display frequency for FM 50 kHz step system.

**3. ST PICTO**

Lights up when stereo is received at FM1/FM2.

**4. BAL PICTO**

Lights up when balance is controlled at sound control.

**5. TRE PICTO**

Lights up when treble is controlled at sound control.

**6. BAS PICTO**

Lights up when bass is controlled at sound control.



FUNCTION AND DISPLAY

Function and LCD display of this machine is explained here.

1. Normal condition

From OFF condition, by pressing "POWER" button the radio turns ON and receives presently selected frequency.

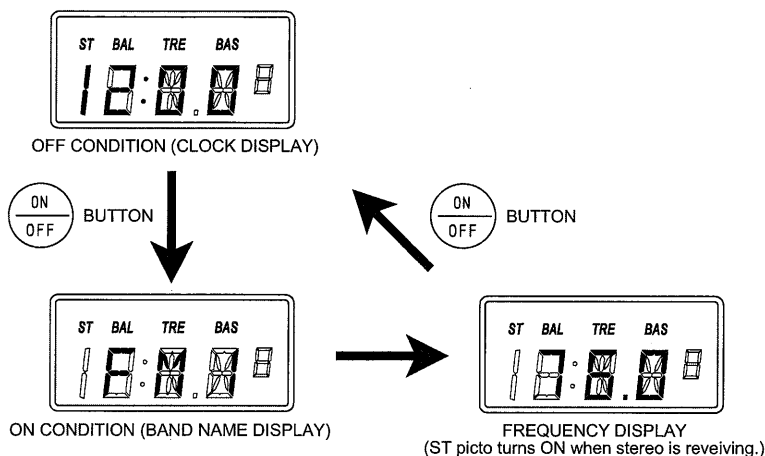

Under this condition, by pressing "DISPLAY SELECT" button (frequency/clock), frequency display and clock display alternates.

(When display is changed from clock display → frequency display, band name is displayed for 1.5 seconds and then changed to frequency displayed.)

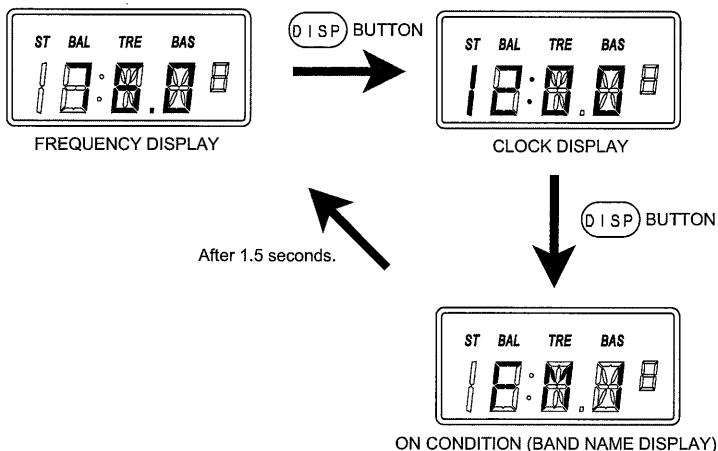

2. Band select

From normal condition by pressing AM/FM select button, band is changed.

After band is selected, radio receives the last selected frequency of the band.

Selecting sequence is FM1 → FM2 → AM → FM1.

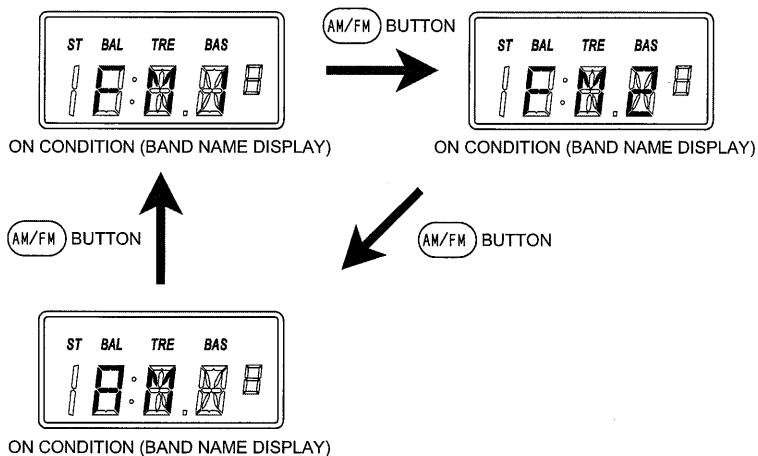

3. Frequency control (1 step up or 1 step down)

From normal condition, by pressing "UP" side of Tuning, various control button, frequency goes 1 step up.

By pressing "DOWN" side, frequency goes 1 step down.

(At FM receiving, frequency is controlled by 0.1 MHz per 1 step and at AM receiving, by 9 kHz per 1 step.)

• When selected band is FM1, FM2.

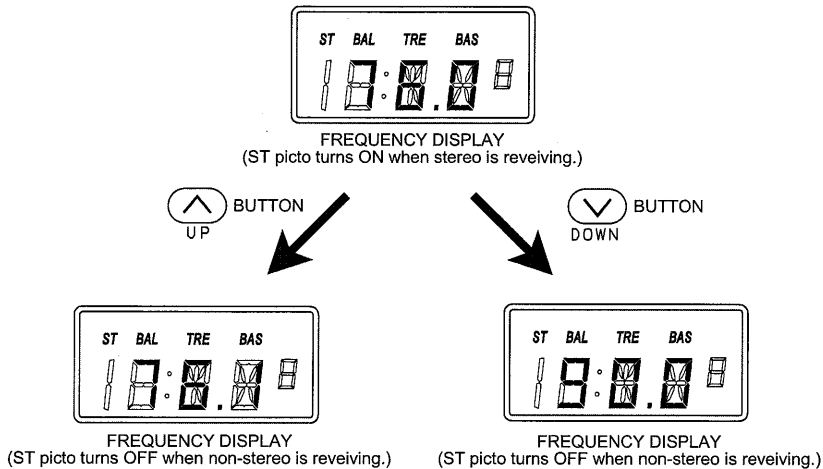

• When selected band is AM.

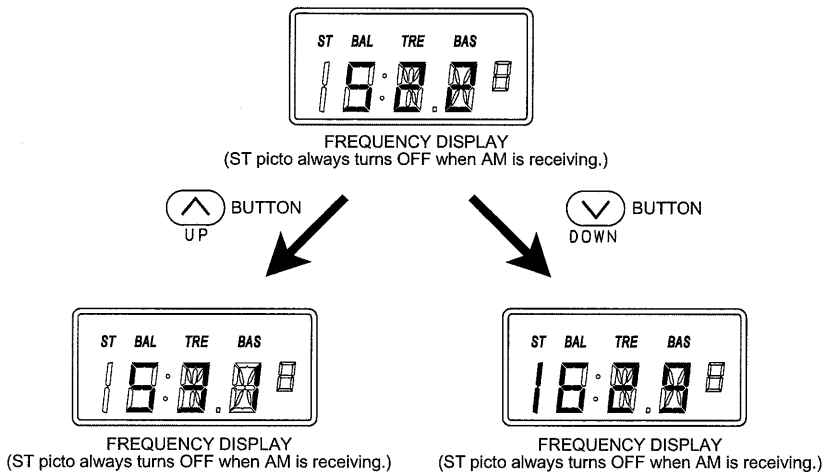

4. Frequency control (auto seek)

From normal condition, by press-holding "UP" side of "TUNING VARIOUS CONTROL" button, frequency goes up by 1 step for continuously.

By press-holding "DOWN" side, frequency goes down by 1 step for continuously.

By searching for good receiving frequency, auto seeking function stops and radio turns to receiving condition.

• Example when selected band is FM1.

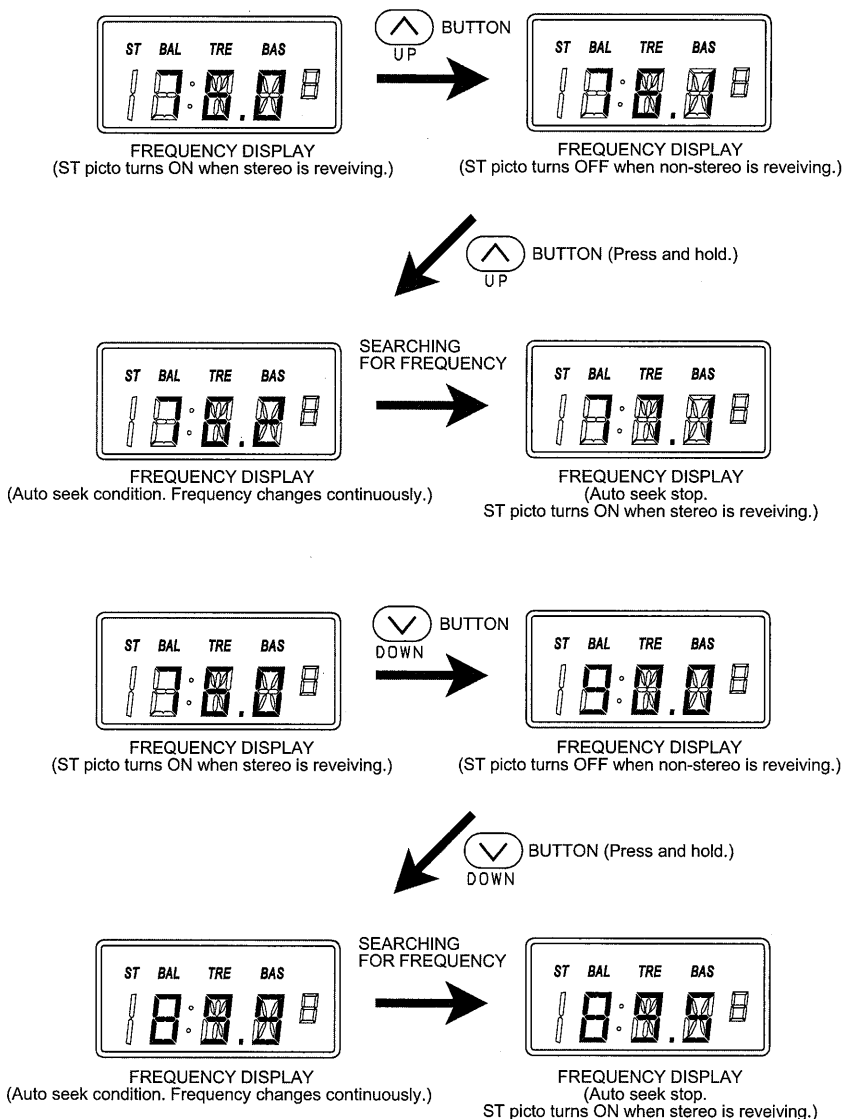

5. Frequency control (auto preset)

From normal condition, by press-holding Sound control button good receiving frequency is automatically detected and memorized to the preset memory 1 to 6 (auto-preset function).

During auto preset, auto preset display as shown below is displayed ("A" display changes a certain interval) and this display ends with 2 beep sounds and preset 1 memorized frequency is received.

• Example when selected band is FM1.

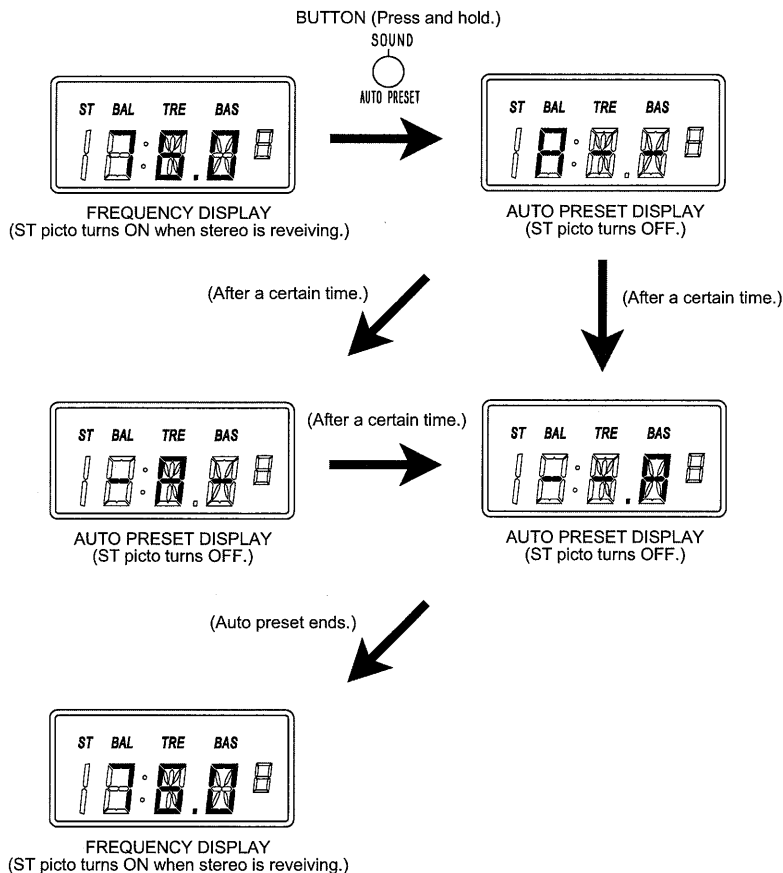

6. Preset call

From normal condition, by pressing preset button (1 to 6), memorized frequency on preset No. is called and received.

- **Example when selected band is FM1
(76.0 MHz is pre-memorized in preset No.1).**

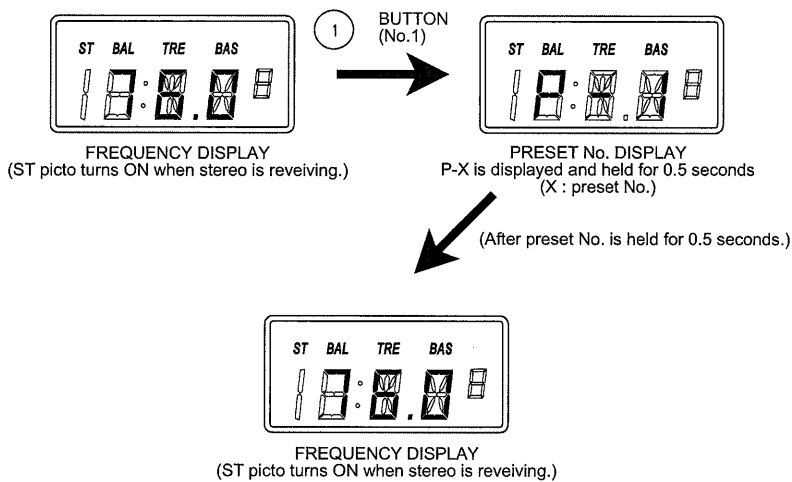

2.2.7 1WAY CALL (TRANSMITTER)

1. Configuration of 1way call

The 1way call comprises the amplifier, microphone, and external speaker.

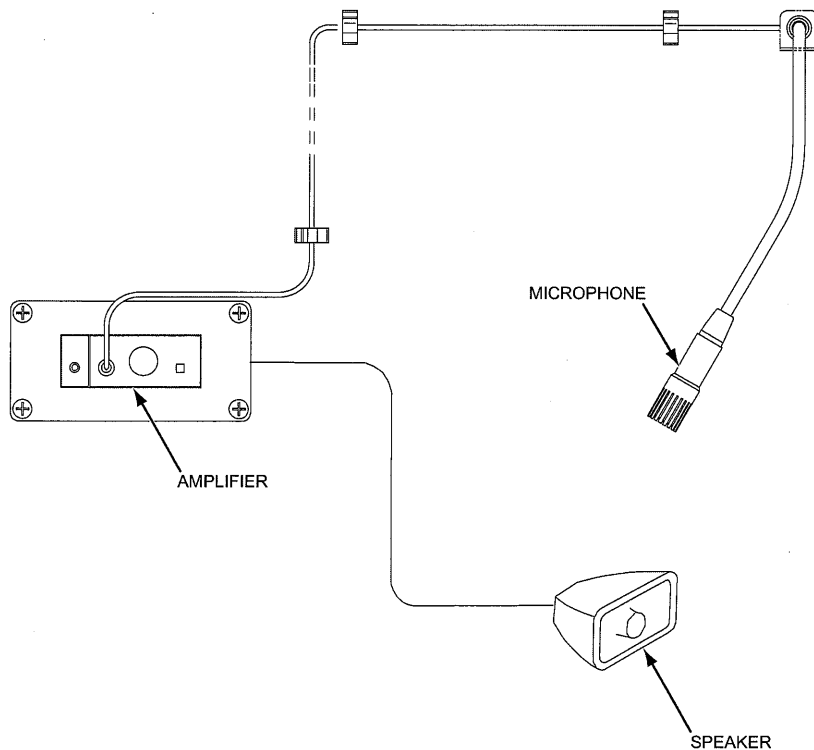

2. Operation instruction

- (1) Set the power switch to the "ON" position.
- (2) The operator's voice can be transmitted through the outside speaker by talking to the microphone.
- (3) The volume of the speaker can be adjusted with the volume adjuster.

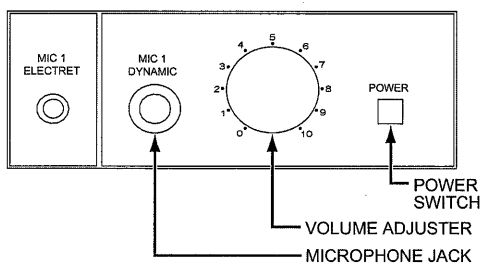

2.2.8 CAMERA MONITOR (OPTION)

It can check each drum wire rope winding condition or rear area of main machinery in the operator's cab.

The camera monitor can check the following location.

- (A) Front drum
 - Rear drum
 - Third drum (Option)
- (B) Boom hoist drum
- (C) Rear of main machinery

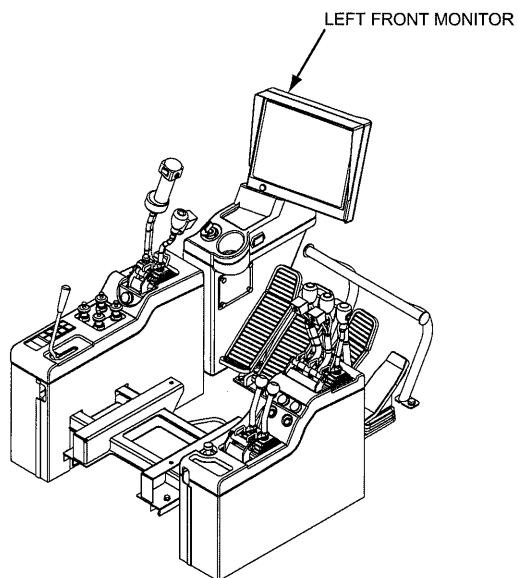

By camera monitor, individually equipped location (A), (B), (C) can be viewed by selecting the screen.

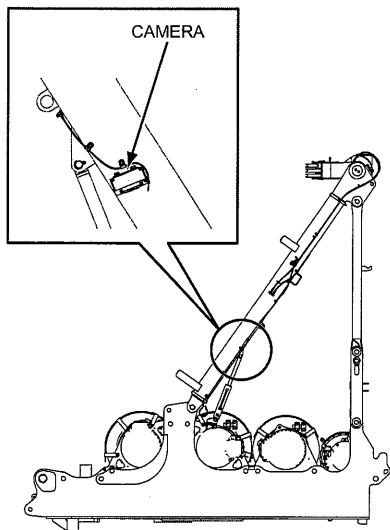

(A) location

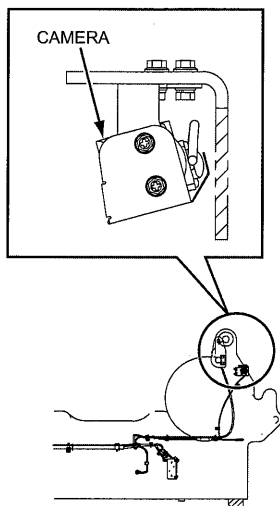

(B) location

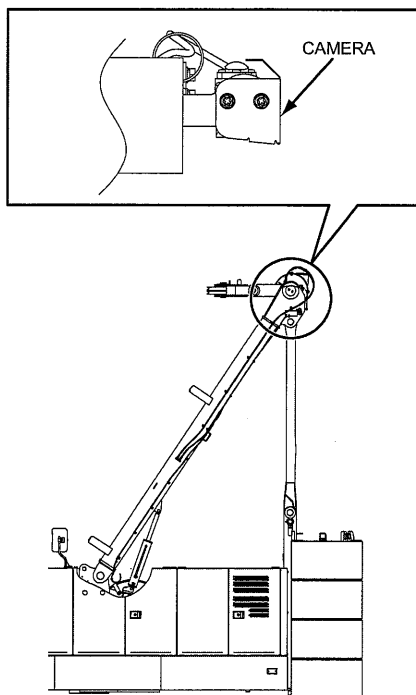

(C) location

Image indicating of monitor camera

Push the camera select icon in the monitor.
Camera image is indicated on right lower of the monitor.

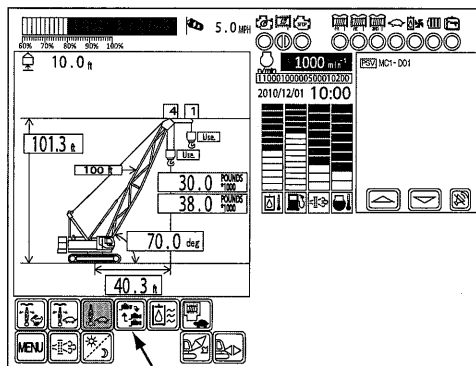

CAMERA SELECT ICON

Selection of camera

Maximum 4 cameras can be connected.
When more than 2 cameras are connected,
camera can be selected in order by touching
the camera image indicating area.
Select the required camera.

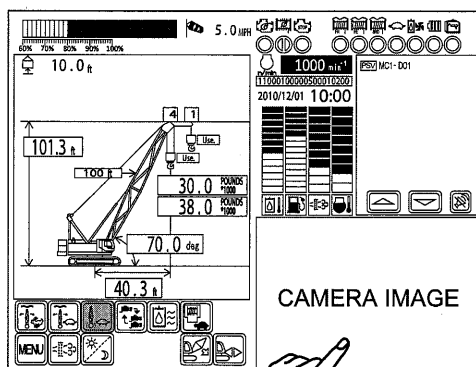

CAMERA IMAGE

Change of camera indicating position

When the machine inclination (option) or swing
angle are indicated on right lower area of
monitor, camera image can be indicated on right
upper of the monitor.

When the camera image is indicated on right
lower, pushing the camera select icon can
change the image indicating position to right
upper.

By pushing the camera select again, separate
camera images can be indicated.

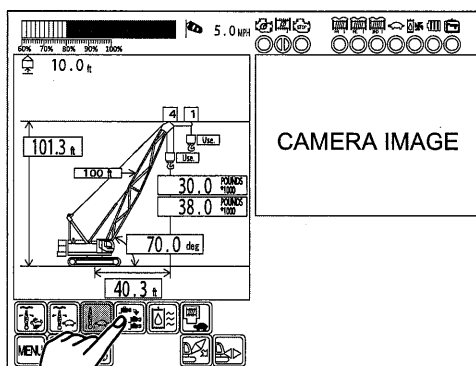

CAMERA IMAGE

2.3 CRANE OPERATION

2.3.1 ADJUSTING THE OPERATOR'S SEAT

CAUTION

Adjust the operator seat to the position where the brake pedal can be firmly depressed.

During the seat adjustment, stop the engine and be sure not to move the control lever. If the control lever moves, return it to the neutral position.

NAME OF EACH MOVABLE PORTION

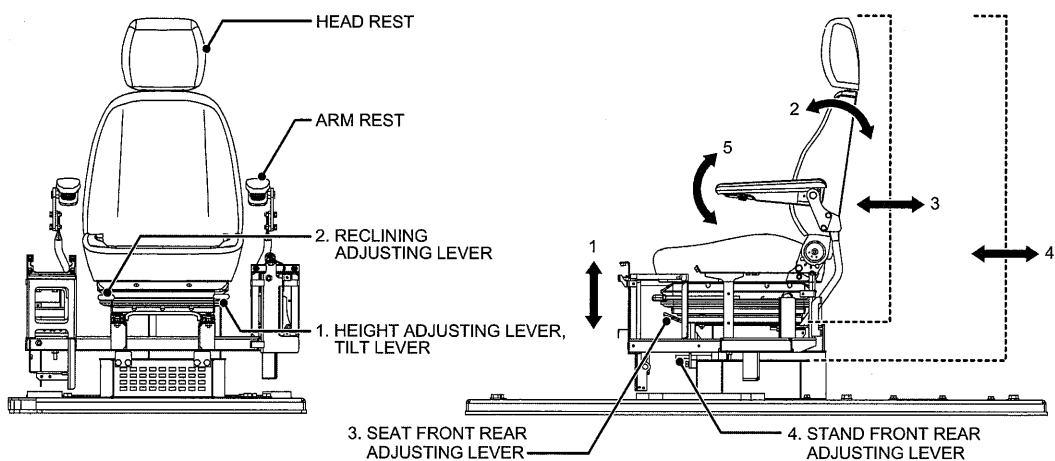

ADJUSTING OF EACH AREA

1. HEIGHT ADJUST, TILT LEVER

- (1) When the lever is pulled up, rear portion of the seat tilts up or down. (Tilt on 5 steps)
- (2) When the lever is pushed down, front area of seat tilt up or down. (Tilt on 5 steps)
- (3) Seat height adjustment can be done by tilting of seat front and rear alternately.

2. RECLINING ADJUSTING LEVER

Adjust the seat back to the required angle by pulling up the lever.

After adjusting, release the lever to fix.

3. SEAT FRONT AND REAR ADJUSTING LEVER

Lift the lever up and move the seat by sliding back and forth.

After adjusting to the required position, release the handle and make sure that the seat is firmly locked.

(Adjusting range : 160 mm [6-5/16 inch])

4. STAND FRONT AND REAR ADJUSTING LEVER

Lift the lever up and move the whole seat and control stand sliding back and forth.

(Adjusting range : 60 mm [2-3/8 inch])

5. ARM REST

The arm rest can be lifted up toward rear.

In addition, by turning the lower control dial by hand, arm rest angle at normal position can be fine-adjusted up or down.

2.3.2 GETTING ON OR OFF THE OPERATOR SEAT

Use the under cab deck step to get on or off the operator seat.

CAUTION

Take extra care not to have your hand caught during opening or closing the operator's cab door. Take extra care not fall off from the step during getting on or off the operator's cab door.

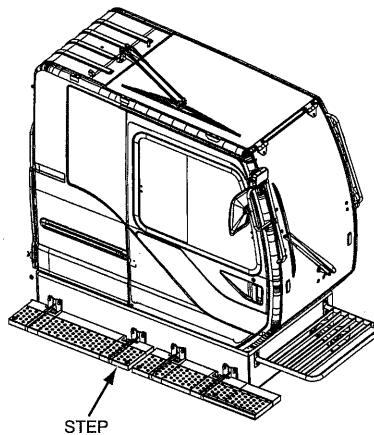

2.3.3 STARTING AND STOPPING THE ENGINE

1. Starting the engine

Before starting the engine, set the control levers and switches as follows :

(1) Front drum, rear drum, third drum (option), boom hoist, swing and propel control lever	Neutral
(2) Function lock lever	Lock position
(3) Swing brake switch	Engaging side
(4) Front drum, rear drum, boom drum and third drum (option) lock knob	Lock side
(5) Front drum, rear drum and third drum (option) brake pedals Release switch master key, free fall lock switch	Lock position

WARNING

Ensure to set all the control levers to neutral position before starting the engine to prevent unexpected movement of machinery when the engine is started.

Even if each control lever of front drum, rear drum, third drum (option) is not in neutral position, engine can start.

However each motion can not work without returning the control lever to neutral position once.

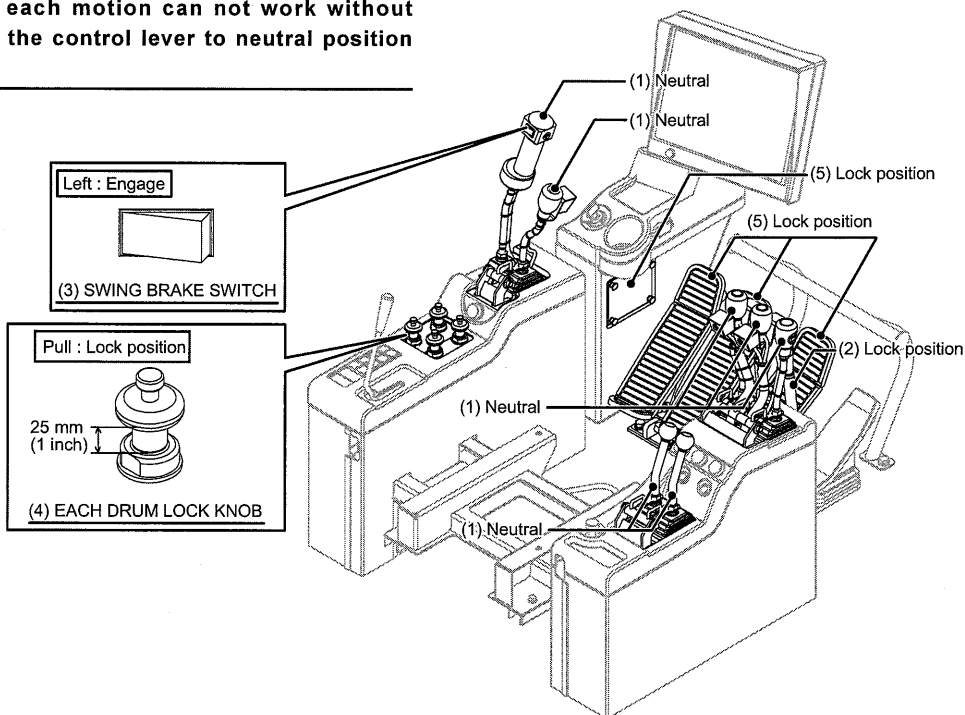

WARNING

Sound the signal horn to warn the surrounding personnel before starting the engine.
Failure to observe this precaution may result in a serious injury or loss of life.

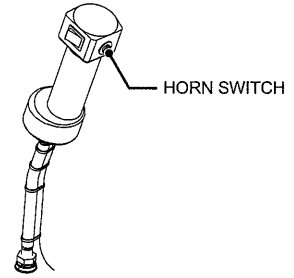

SWING CONTROL LEVER

- (1) Turn the key switch 2 steps to the right (ON position).
Confirm that the engine abnormal detect lamp lights up at this time.
Confirm that the engine emergency stop switch is released.

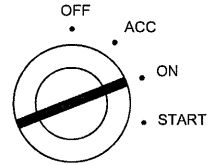

KEY SWITCH

KEY SWITCH

OFF	Engine shut off position
ACC	Accessory ON position
ON	Engine run position
START	Engine start position

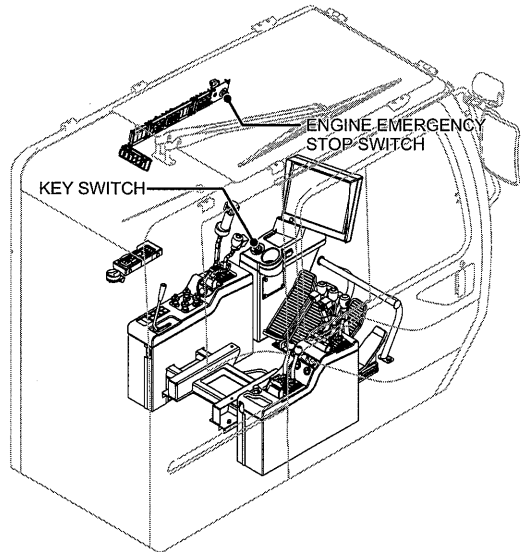

- (2) By turning the key switch one step more to the right ("START" position), the engine starts.
After the engine starts, immediately release the key.
The key returns to the ON position automatically.

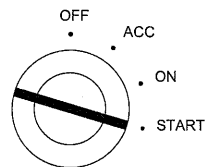

CAUTION

Do not allow the starter to run more than 15 seconds continuously.
If the engine does not start within 15 seconds, release the key and wait for more than 20 seconds, then start the engine again.

- (3) After the engine starts, immediately check the monitor for abnormality.
If there is any abnormality, stop the engine immediately and seek for the cause.

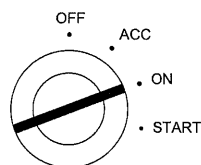

- (4) To adjust the engine speed, use the accelerator grip.
If the engine speed adjustment becomes impossible by the accel grip due to accelerator failure, use the auxiliary accel switch.

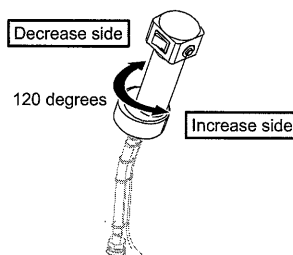

SWING CONTROL LEVER

CAUTION

Do not operate auxiliary accelerator when the system works properly.
If auxiliary accel switch is used when the accel grip is normal, engine speed adjustment can not be done with the accel grip.

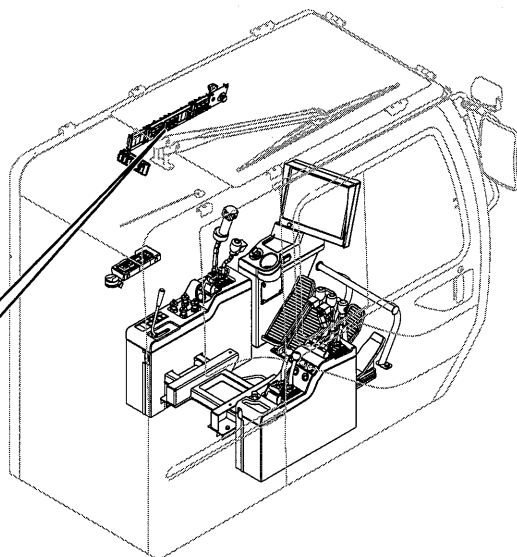
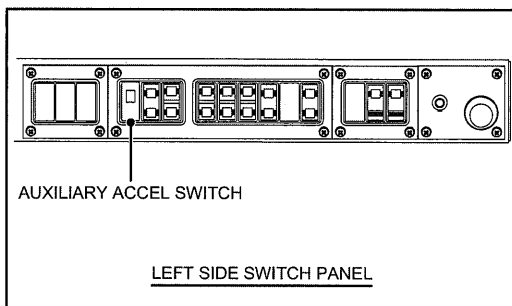

2. Engine warming operation

Allow the engine to run at less than middle engine speed ($1,000 \text{ min}^{-1}$ [1,000 rpm]) for 5 to 10 minutes with no load.

Extend the warm-up time to 10 to 20 minutes in a cold area with the same speed.

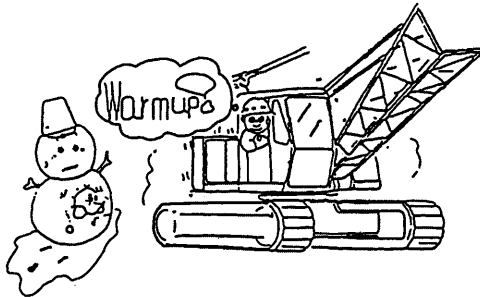

CAUTION

If the crane is operated without warming up the engine, the engine and the hydraulic components will be worn out earlier than usual or will be damaged.

3. Engine abnormal

When engine abnormal occurs, the engine control unit (ECU) detects it and engine abnormal detect lamp (red) lights up on the monitor.

Immediately turn the key switch to OFF to stop the engine and contact the KOBELCO service shop.

If the engine must be stopped urgently, push the engine emergency stop switch.

The switch is held at the pushed position and return to original position when turned right.

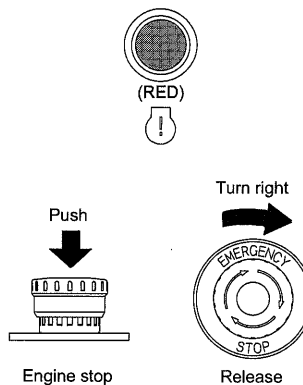

4. Shutting off the engine

Before stopping the engine, set the control levers and switches as follows :

(A) Front drum, rear drum, third drum (option), boom hoist, swing and propel control lever	Neutral
(B) Function lock lever	Lock position
(C) Swing brake switch	Engaging side
(D) Front drum, rear drum and third drum (option), boom drum lock knob	Lock side
(E) Front drum, rear drum and third drum (option) drum brake pedals	Lock position

2

- (1) Allow the engine to run at low speed for approx. 5 minutes with no load before shutting off the engine.
- (2) Turn the key switch to the OFF position. After the engine is stopped, the power will be cut after awhile.

During this period, message will be indicated on the monitor urging to engage the drum lock. If the emergency solenoid becomes actuated, the power will be cut after about 90 seconds.

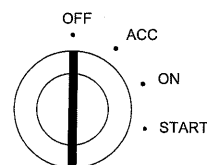

5. Soot burning (regeneration)

When the soot are accumulated to higher than certain level in the diesel particulate filter, the regeneration mode becomes actuated and burn the soot by raising the exhaust gas temperature. There are the following modes in soot burning (regenerating).

(1) Refresh mode

Since non-combusted fuel is accumulated in DPF unit when low idling or light load work continues for long time, automatic refreshing occurs. (This is not regeneration)

(2) Auto regeneration mode

Burning (regenerating) the soot occurs automatically and the crane operation can be done even during auto-regeneration.

(3) Manual regeneration mode

Burning (regenerating) the soot occurs manually and the crane operation is not possible during the regenerating process.

 CAUTION

When the soot accumulation gauge icon starts blinking gray and yellow (explained later) automatically, the load valve is working to raise the exhaust gas temperature.

The blinking occurs when the refresh mode or the auto regeneration mode is on.

In such case, avoid starting or stopping the engine as much as possible.

Once the load valve is stopped, fuel so far used to raise the exhaust temperature becomes wasted and parts deterioration may be resulted.

(A) Refresh mode

Procedure

- When low idling or light load work continues for long time, refreshing of DPF starts.
- Refresh mode functions regardless of the soot accumulation amount.
- When this mode is started, engine speed is increased to $1,000 \text{ min}^{-1}$ (1,000 rpm) and the load valve actuates.

2

CAUTION

Under refresh mode and the engine speed exceed $1,100 \text{ min}^{-1}$ (1,100 rpm), this mode is cancelled.

Since refresh again needs a few minutes to keep that condition, once it is cancelled, it must be started again.

When the refreshing is started, keep that condition as long as possible and do not stop the engine or cancel the refreshing.

CAUTION

When non combusted fuel is accumulated, white smoke may come out of exhaust port and may cause deterioration of DPF unit.

- When the soot accumulation gauge icon becomes off (gray color), refresh is completed.

CAUTION

Refresh is completed in about 5 minutes.

(B) Auto regeneration mode

Procedure

- When certain amount of soot is accumulated, auto regeneration starts.
(When soot gauge is approx. between 3rd to 4th block)

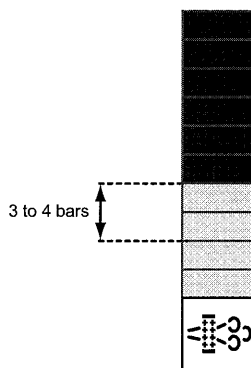

- Auto regeneration is actuated when control lever is not used and soot burning (regenerating) starts automatically.

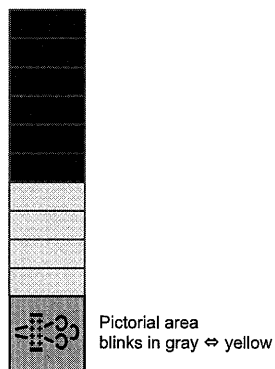

CAUTION

In the auto regeneration mode, engine idling speed may raise (Max. 900 min⁻¹ [900 rpm]). Load valve condition is displayed and buzzer sound is issued to call for caution. Furthermore, auto-regeneration mode and approx. period are displayed, in the monitor.

- Crane operation is possible during auto regeneration.

CAUTION

During auto-regeneration, increasing the engine speed may cause louder engine noise. This is because of the regeneration required control is functioning and is normal.

- When the soot accumulation gauge icon becomes off (gray color), the auto regeneration is completed.

CAUTION

Auto regeneration will be completed in about 5 to 10 minutes. (It varies depending on the volume of soot accumulation.)

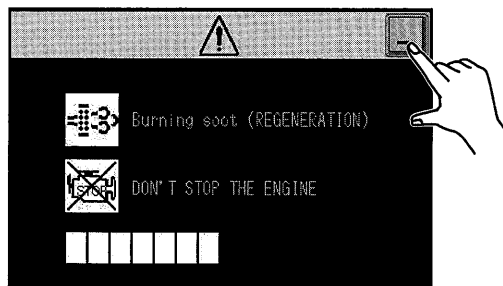

2

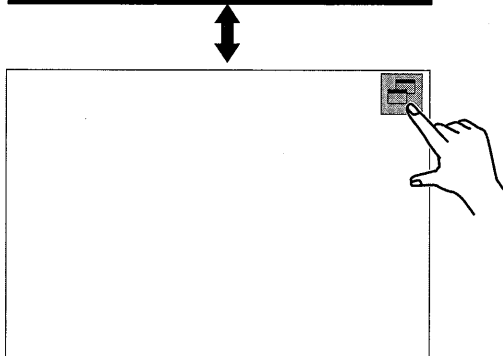

Warning screen can be minimized or maximized by touching the icon right above.

Cancel

- During auto regeneration, when the cancel icon is indicated, the auto regeneration can be cancelled by pressing the cancel icon.

CAUTION

**When cancelled, soot burning (regenerating) is not completed.
The soot accumulation gauge will be reset.**

- After the cancellation, when the control lever becomes non operational, auto regeneration mode starts again.
- Cancel button is displayed by changing the setting.
Display the setting change screen with  icon and select ON or OFF.

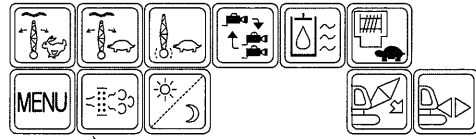

CANCEL ICON

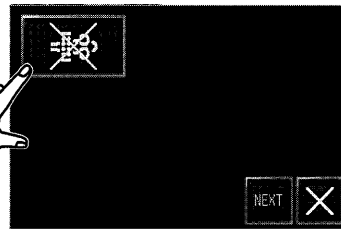
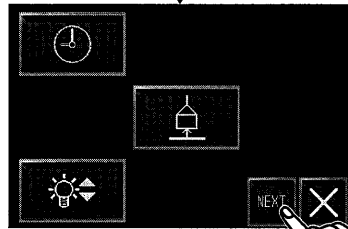
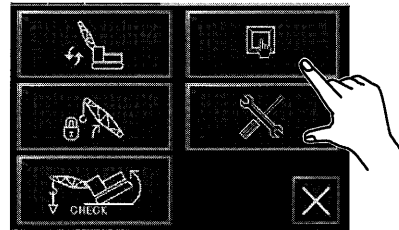
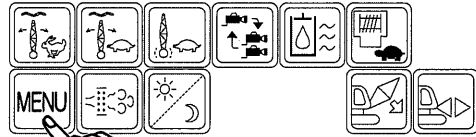

Press and hold for 1second or longer.
ON: Display of cancel icon
OFF: Non display of cancel icon

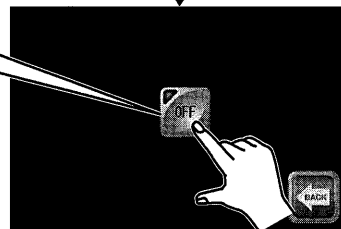

(C) Manual regeneration mode

Procedure

- When the soot accumulation gauge becomes in the range of 5 to 8 bars a, request for manual regeneration pops up in main monitor as pop-up.

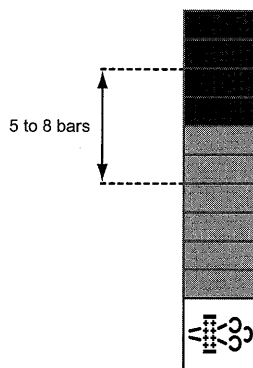

2

- Reduce the engine rpm to idle and press the soot burning (regenerating) icon.

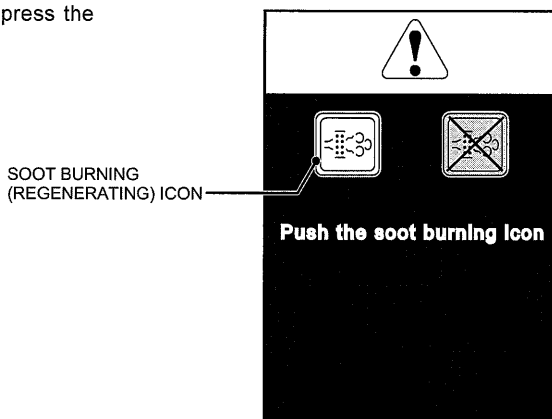

- Manual regeneration becomes actuated and soot burning (regenerating) will start.

Note

During the manual regeneration mode, engine rpm becomes fixed to 1,000 min⁻¹ (1,000 rpm) and the load valve becomes actuated.

In this mode, soot accumulation gauge icon blinks gray and yellow alternately and time gauge becomes displayed on right lower of the screen to show that the regeneration is on.

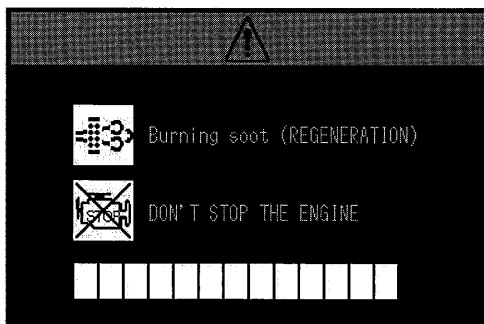

- During manual regeneration process, lever control will not be actuated.
- When the idling speed returns to original and soot accumulation gauge icon turns off and the soot accumulation gauge is reset, manual the regeneration is completed.

Note

Manual regeneration will be completed in about 15 to 20 minutes. (It varies depending on volume of soot accumulation.)

Since soot burning (regeneration) raises the temperature in the diesel particulate filter to a certain level, the process will be completed faster if the temperature in the diesel particulate filter is higher.

Soot burning (regeneration) will complete earlier right after crane work than when engine is cold.

When the engine is cold, soot burning (regeneration) actuates only after warming the engine. Therefore it may take longer than 20 minutes.

Cancel

- When the manual regeneration request screen is indicated but responding to the request is not possible, cancellation can be selected.

Note

Selecting the cancel option has limitations.
When the soot accumulation gauge reaches 8 bars, cancel icon will not be indicated.
Perform regeneration at early stage.

CAUTION

When cancelled, soot burning (regenerating) is not completed.
The soot accumulation gauge will not be reset.

- When machine operation becomes necessary even during manual regeneration process it can be suspended by pressing cancel icon.

Note

Selecting the cancel option has limitations.
When the soot accumulation gauge reaches 8 bars, cancel icon will not be indicated.
Halt operation and wait until completed.

CAUTION

When cancelled, soot burning (regenerating) is not completed.
The soot accumulation gauge will not be reset.

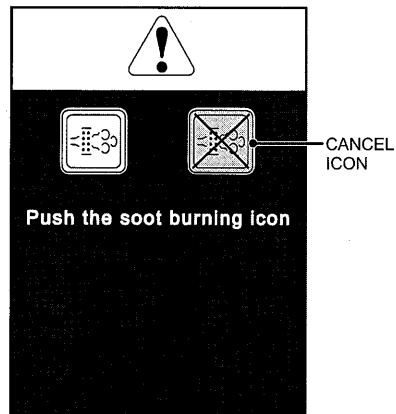

2

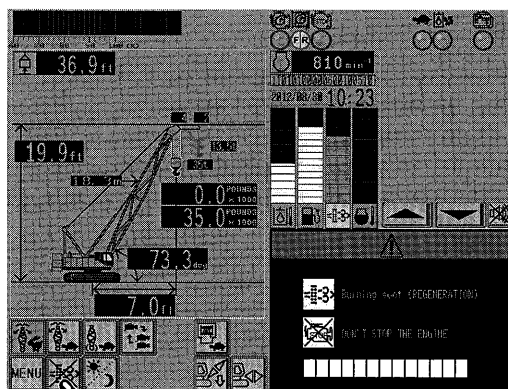

- After cancelled, request screen will not be indicated until gauge bar is become increased by one more bar.
However, since regeneration is always possible, press soot burning (regenerating) icon indicated in main monitor whenever an opportunity is given.

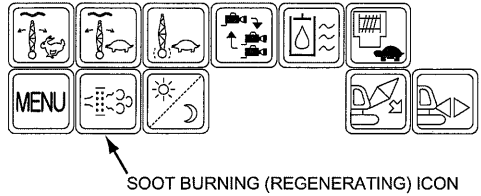

CAUTION

When no action taken for a long time after the manual regeneration request screen is indicated and accumulation gauge reaches 9 bars, a forced soot regeneration will occur to prevent failure of the diesel particulate filter.
Halt operation and wait until the regeneration is completed.

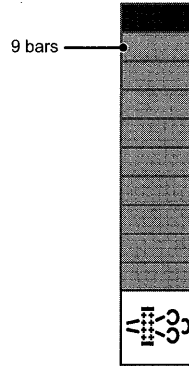

CAUTION

When the soot accumulation gauge reaches 10 bars, the diesel particulate filter could malfunction and error would be indicated in the main monitor.
Contact the nearest KOBELCO service shop and request of replacing the diesel particulate filter and error reset.

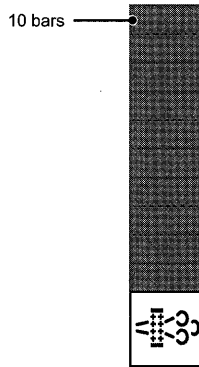

CAUTION

Do not wash the engine area with high pressure water.
During engine running (specially during the diesel particulate filter is under burning (regeneration) work, if the high pressure water hit the diesel throttle etc. water may enter into the engine and may cause damage to the engine.

2.3.4 AUTO IDLE STOP FUNCTION

This function is designed to stop the engine while no operation of the crane is mode to conserve fuel.

When the "AUTO IDLE STOP SWITCH" is ON, a table showing the auto idle stop conditions is displayed on the main monitor.

- * If the machine has an error, this table will not be displayed, since the priority is given to display the error message.

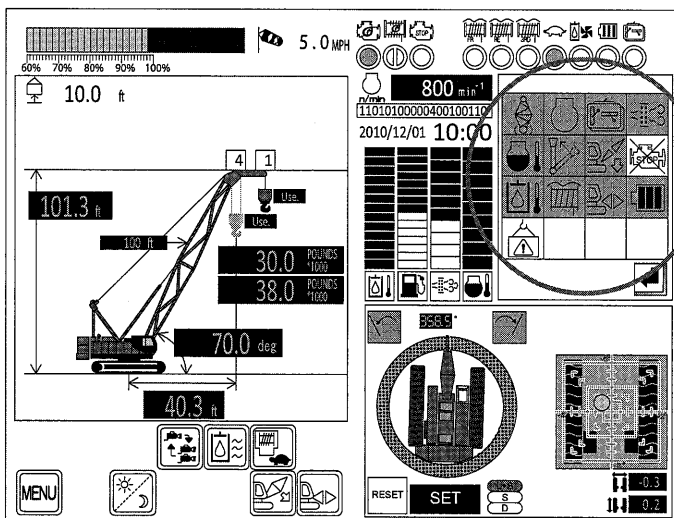
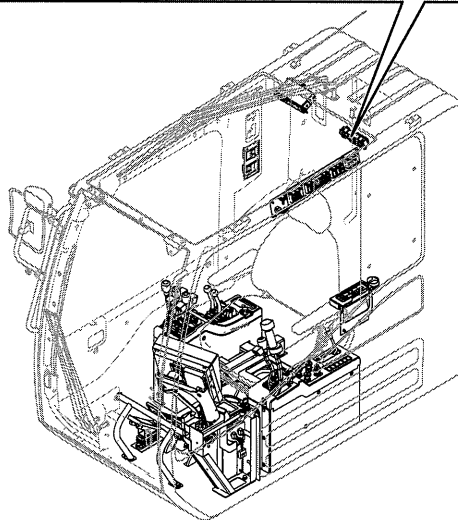
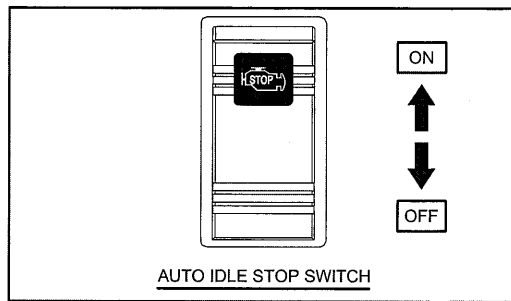













Explanations of the conditions

Required conditions are described as below.

When the requirements are met, the applicable conditions light up in green color.

When all of the conditions are satisfied, the countdown begins.

(1)		Swing brake	The swing brake is ON.
(2)		Engine rotational speed	The engine rotational speed is 760 to 840 min ⁻¹ (760 to 840 rpm).
(3)		Remote control	Remote control for translifter self installation and removal device shall not be connected yet.
(4)		DPF regeneration	DPF regeneration is not in progress.
(5)		Engine coolant temperature	The engine coolant temperature is within the specified range.
(6)		Control lever	All control levers are in the neutral position.
(7)		Self stowing mode	LMI shall not be in the self stowing mode.
(8)		AIS cancel	At least 5 min is passed after the "AIS CANCEL" icon is pressed.
(9)		Hydraulic oil temperature	The hydraulic oil temperature is within the specified range.
(10)		Winch mode	All winches are neutral brake mode.
(11)		Assy/disassy mode	LMI shall not be in the assembly/disassembly mode.
(12)		Battery	The battery residual shall be above the specified level.
(13)		Lifting load	The lifting load is lower than the specified.

* However this condition does not need to become to start the countdown.
(May require longer time)

When the conditions are satisfied, the countdown message shown is displayed.

When the numeric value displayed reaches zero, the engine is stopped.

When the icon (a) is pressed, the engine can be stopped, even if the countdown is on the way.

When the icon (b) is pressed, the countdown is cancelled.

When this icon is pressed, the subsequent countdown does not start for 5 min.

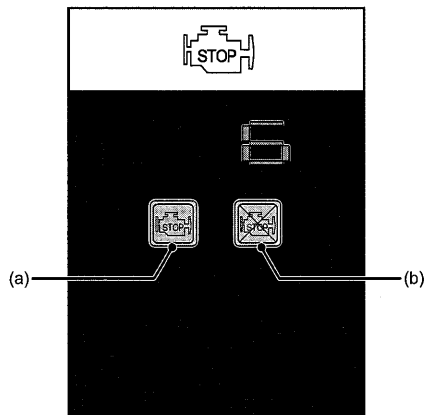

When the engine is stopped by the auto idle stop function, the engine can be restarted by turning the accelerator grip.

Turn the accelerator grip by approx. 1/4, then put it back in the low idle position.

- * Restart with the key switch is also possible.

Note

During auto idle stop of the engine, the battery power is used.

When you leave the operator's seat, be sure to turn OFF the key and take all safety measure.

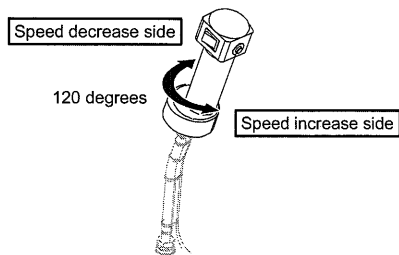

SWING CONTROL LEVER

2.3.5 FUNCTION LOCK LEVER

When operating the machine, place the function lock lever in the "WORK" position.

When leaving the operator's seat, be sure to place this lever in the "LOCK" position.

When this lever is placed in the "LOCK" position, the machine is not operated even if any control lever is operated accidentally.

Ensure to place the function lock lever to "LOCK" position after the work is completed and during transportation.

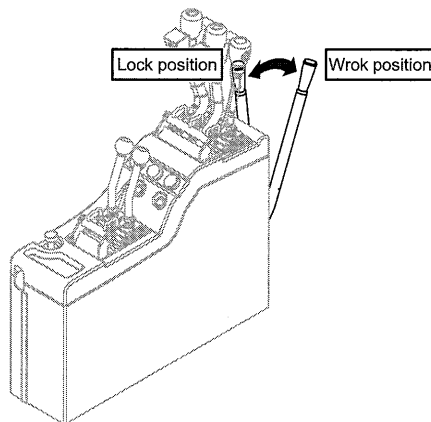

Note

If the function lock lever is set to the "LOCK" position while any of front drum, rear drum boom hoist drum and propel control lever is operated, rotation of the drum or propel is stopped.

Under this condition, even if the function lock lever is returned to "WORK" position, no motion becomes operational.

After the control lever is returned to the neutral position, the control becomes possible again.

! DANGER

Do not set the function lock lever to the "LOCK" position during operation.

Otherwise, all the operation functions are suddenly stopped, causing extreme danger.

Failure to observe this precaution may result in a serious injury or loss of life.

2.3.6 PROPELLING OPERATION

⚠ WARNING

Strictly observe the following before propel.
Confirm that people and obstacles are kept out of the propelling area.

Sound the horn to warn the surrounding people.
Be especially careful, when the boom is long, boom angle is high, ground is uneven, or when a load is lifted.

For stability of swinging and traveling, refer to the article 8 "STABILITY IN SWING, PROPEL".

Use a signal person to direct operation.

Failure to observe this precaution may result in a serious injury or loss of life.

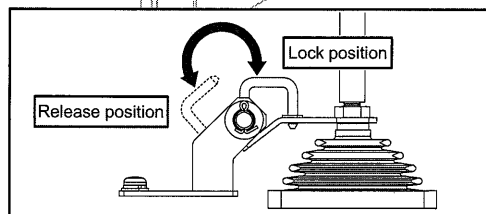
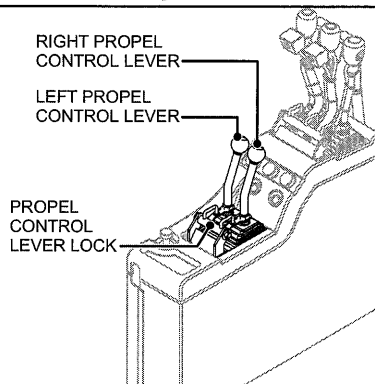
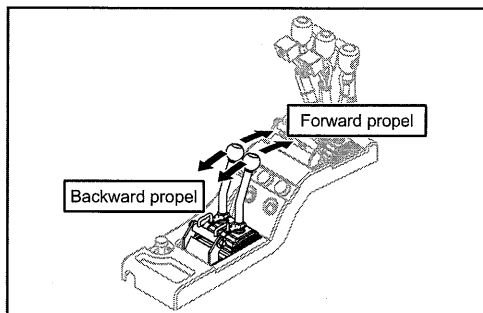

Propel speed is regulated by turning the accelerator grip, and by proportionally pushing and pulling the propel control levers.

High and low propel speed is regulated by operating the propel speed selector switch.

- **High speed**
Use this speed on good ground conditions.
- **Low speed**
Use this speed when a tractive force is required on bad ground conditions.

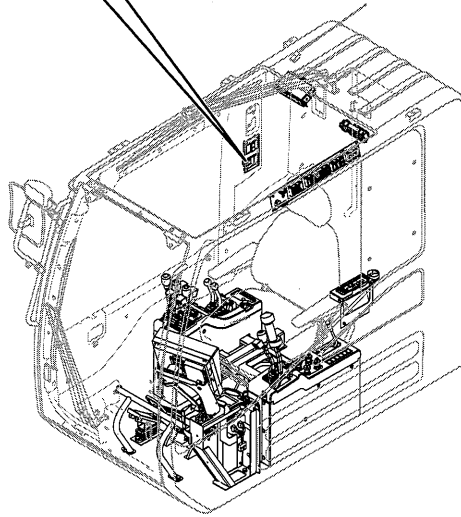
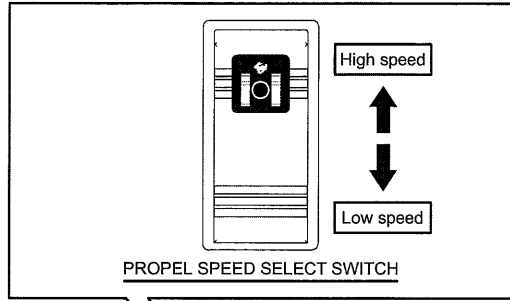

When the propel speed selector switch is placed in the High speed position, pivot turn and spin turn due to large propel resistance cannot be operated.

Turn the switch to Low speed position for pivot turn and spin turn.

Since the machine may propel partially on a rough terrain, adjust propel speed by the stroke of the propel control levers.

In order to identify front and rear of the lower machinery, the crawler shoes have "△" marks.

Propelling forward is propelling toward the idler side, and propelling backward is propelling toward the propel motor side.

When the cab positions to the propel motor side, use caution with propelling operation in reverse only.

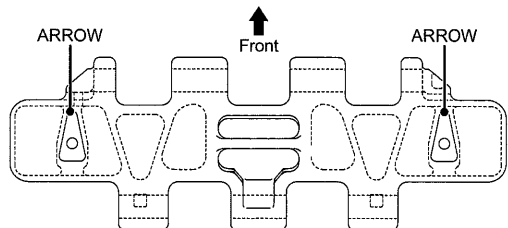
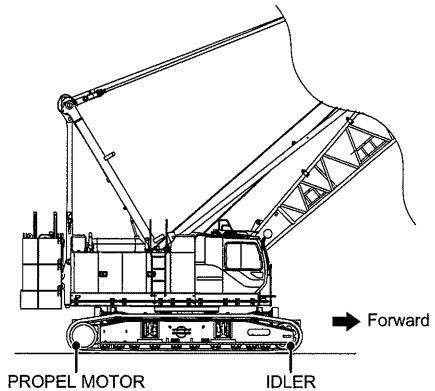

1. Release the propel control lever lock.
2. Select High or Low speed by propel speed select switch based on the propel work.
3. It is possible for the machine to perform propelling forward/backward and pivot turn/spin turn/large radius turn by operating the right and left propel control levers.
4. Engage the control lever lock when you do not want to propel the machine.

WARNING

Do not perform sudden starts/stops/operation of the machine. Failure to observe this warning may result in a serious accidents.

If the front or rear drum is operated while propelling the machine, it may cause danger because the propel speed and/or the direction.

To perform these simultaneous operation, slow down the propel speed and slowly operate the drum.

CAUTION

When the machine has propel on a slope, improve the stop condition before propelling so that the machine will be able to propel safety.

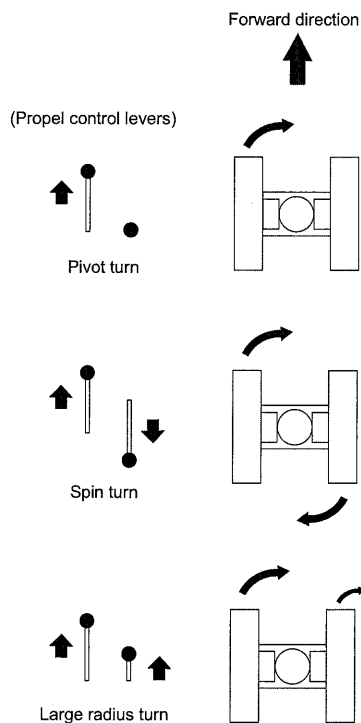

2.3.7 SWINGING OPERATION



Before starting any swing operations, ensure the area in the swing path of the hook and/or load, and the tail swing area, is clear of all obstructions and personnel.

Sound signal horn to warn personnel.

For stability of swinging and traveling, refer to the article 8 "STABILITY IN SWING, PROPEL".

Failure to observe this precaution may result in a serious injury or loss of life.

Swing speed is regulated by turning the accelerator grip, and by proportionally pushing and pulling the swing control lever.

1. According to working conditions, select the alarm with the swing alarm selector switch.

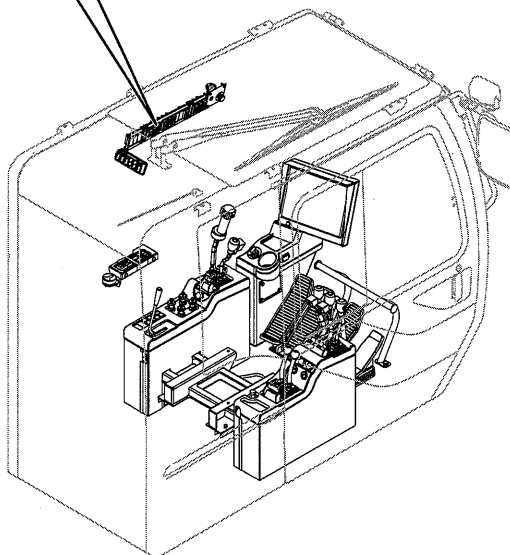
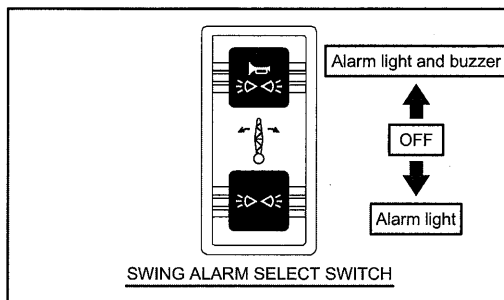

- Select free (high/low) speed or brake (low) by swing mode select switch based on work content.

At the brake mode (low) or free (low), swing max. speed becomes lowered.

WARNING

When the brake mode is selected, do not return the swing control lever to the neutral position too quickly in order to avoid shocks to the machine and booms or load swing.

Failure to observe this precaution may result in a serious accident.

EACH MODE AND WORK CONTENT

FREE : HIGH SPEED	Crane, lifting magnet, clamshell work
FREE : LOW SPEED	Long boom crane work
BRAKE : LOW SPEED	Long boom crane work

- Release the swing lock pin and swing brake.

CAUTION

Since the upper machinery may swing naturally due to the wind or ground inclination, pay attention when releasing the swing brake.

Engaging the swing lock pin or swing brake during machine swing may result in attachment damage or machine turn over.

When engine is started while the swing brake is released, or function lock lever is turned from "LOCK" position to "WORK" position, swing brake keeps engaged position.

In such case, turns the swing brake switch to engaged position once and then to released position to release the swing brake.

If the function lock lever is in "LOCK" position, swing brake is engaged regardless of swing brake switch position.

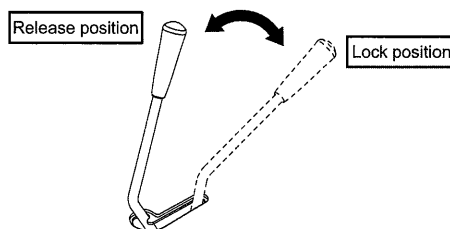
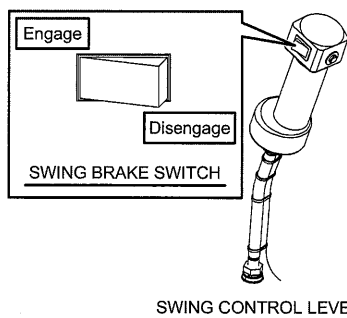
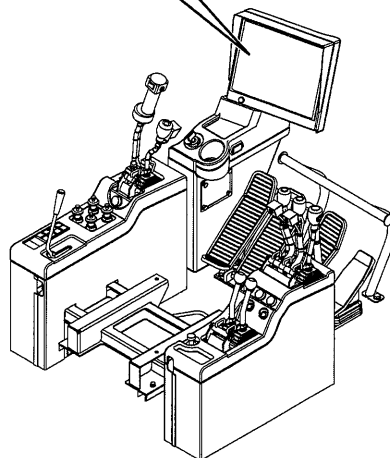
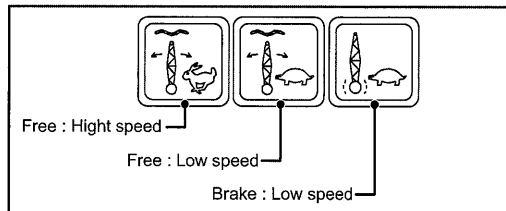

4. Push the swing control lever forward to swing the upper to the left and pull the lever backward to swing the upper to the right.

To stop the swing motion

- **Free mode**
Slowly move the lever in the counter direction.
- **Brake mode**
Slowly return the lever to the neutral position.

In case of strong wind or on the slope, the upper machinery may start swinging by itself.

Therefore engage the swing brake.

For long time stop, engage the swing lock pin.

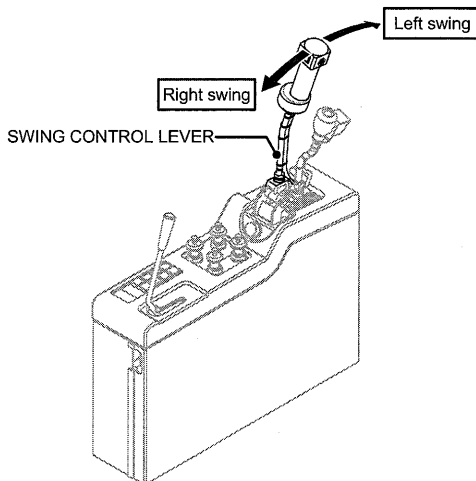

CAUTION

Do not use the swing parking brake for the purpose of stopping the swing motion.

Always check to ensure that the load is hanging free and directly under the boom tip before swinging.

Failure to observe this precaution may result in a serious injury or loss of life.

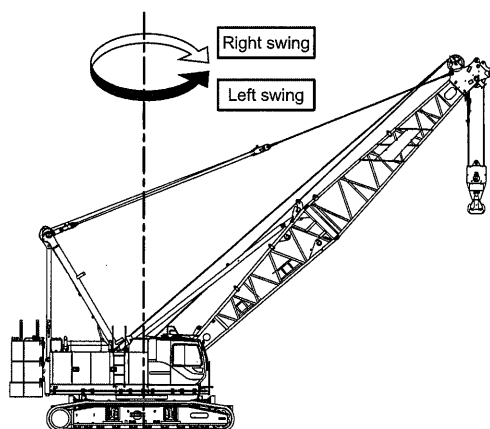

5. When pausing operations, set the machine straight ahead, and then, engage the swing lock.

CAUTION

The position of the upper machinery for swing lock pin is used only if straight over front or over rear against the lower machinery.

Do not apply the swing lock at the other than the positions mentioned above.

2.3.8 BOOM RAISING/LOWERING OPERATION



Before operating the boom, ensure that the area above and beneath the boom is clear of all obstacles and personnel.

Failure to observe this precaution may result in a serious injury or loss of life.

Speed of boom hoist can be adjusted by turning the accelerator grip and pressing or pulling up the boom control lever and the maximum speed of boom up and down motion can be also adjusted by operating the drum speed adjusting trimmer.

1. Release the drum lock by pushing the boom hoist drum lock knob.

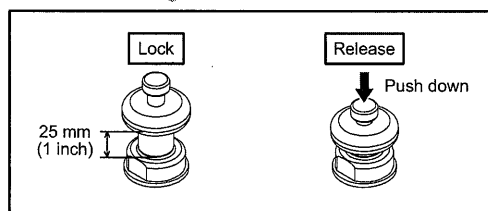
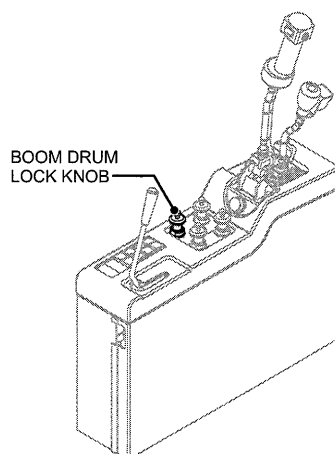

2. Boom raising/boom lowering

Push the boom drum control lever forward to lower the boom, and pull the lever backward to raise the boom.

When the boom is not lowered by operating the boom drum control lever to the boom lowering side, it is possible that the drum lock pawl is engaged in the ratchet of the drum.

In this case, move the boom drum control lever to the boom raising side slightly, then move the lever to the lowering side again.

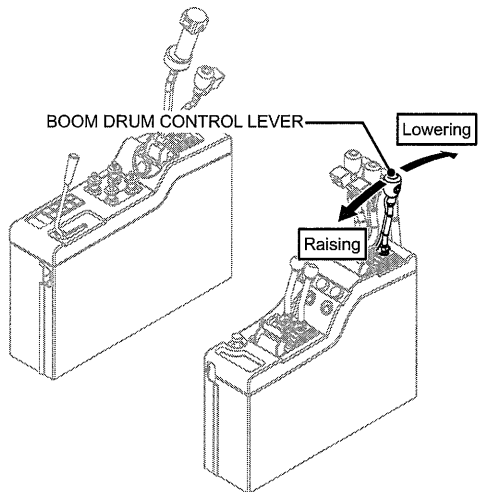

WARNING

Operate the control lever slowly.
Abrupt control lever operation is very dangerous,
and may create the shock to the main machinery
or load swinging.

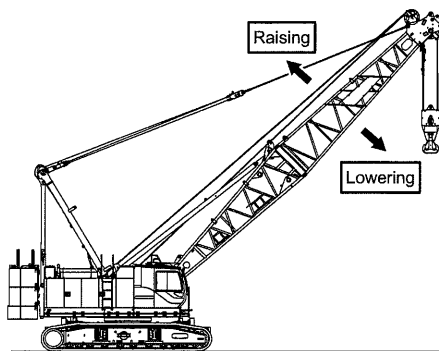

3. Stopping

When the boom drum control lever is returned to the neutral, the drum brake actuates automatically and the boom is stopped and is held.

2

 CAUTION

When returning the control lever to the neutral, ensure that it is returned surely to the neutral position.

 CAUTION

Do not make the boom or jib to come close to the hook.

When the hook contacts the boom or jib, the boom or jib and their wire ropes may be damaged.

 DANGER

Never engage the drum lock while lowering the boom.

The drum or drum lock pawl may be damaged.

- Adjust the drum speed by the drum speed adjust trimmer based on the work condition.

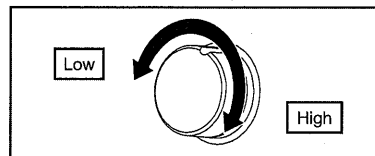
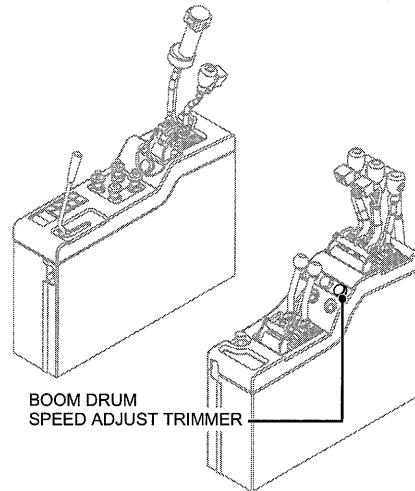

- When the boom approaches the upper limit angle, the hoisting speed is reduced. The angle to start the speed reduction differs depending on the engine speed.
The speed reduction will start at approximately 10 degrees before the upper limit angle in the case of HIGH IDLE and approximately 3 degrees before the upper limit angle in the case of LOW IDLE.
- Be sure to stop the engine, and engage the drum lock before leaving the operator's seat.
To engage the drum lock, push and hold the button, and then fully pull the knob up. Fully pull it up, although the resistance against pulling may be altered halfway.
Check to see if the boom control lever is returned to the neutral and then engage the lever lock.
Turn the function lock lever to "LOCK" position.

2.3.9 HOOK RAISING/LOWERING OPERATION

⚠ WARNING

Ensure that there are no obstacles or personnel within and hanging the hook or load moving area.

⚠ DANGER

Perform the crane work with “NEUTRAL BRAKE” side.

“FREE FALL” side may fall the load by operator’s error.

Failure to observe this precaution may result in a serious accident.

⚠ DANGER

Do not actuate the drum lock while lowering the hook.

Otherwise, the drum or drum lock may be damaged.

⚠ WARNING

When making lifts, strictly follow the capacity charts for determining the loads that can be handled as supplied by the manufacturer.

Follow good operating practice and procedures as outlined in this manual.

Failure to observe this precaution may result in a serious injury or loss of life.

Raising and lowering speed is regulated by turning the accelerator grip and by proportionally pushing and pulling the drum control lever.

The maximum raising and lowering speed of the drum is regulated by operating the drum speed adjusting trimmer.

1. Ensure that the "FREE FALL INDICATOR LAMP" is off.
2. Release the drum lock by pushing the front, rear and third hoist drum lock knob.

⚠ DANGER

Before releasing the drum lock, confirm that the drum brake mode is in the "NEUTRAL BRAKE MODE".

If not, move the switch to the "NEUTRAL BRAKE MODE".

Failure to observe this precaution may result in a serious injury or loss of life.

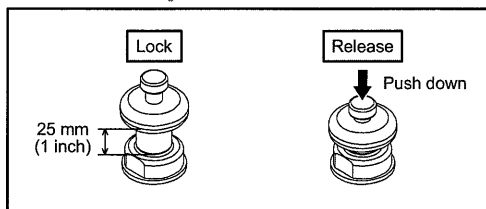
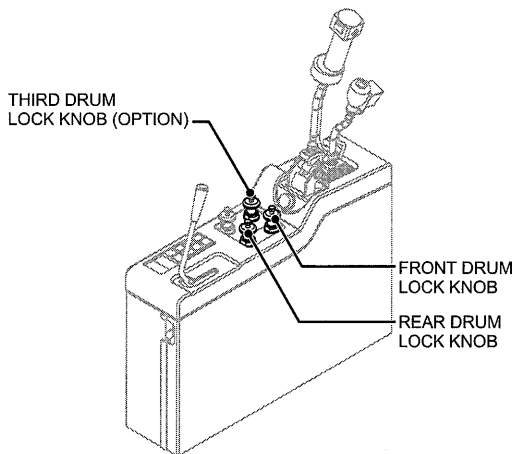

3. According to working condition, adjust the maximum speed of the drum with the drum speed adjusting trimmer.

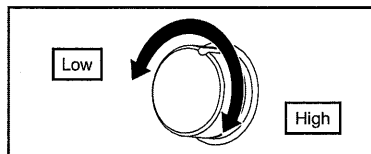
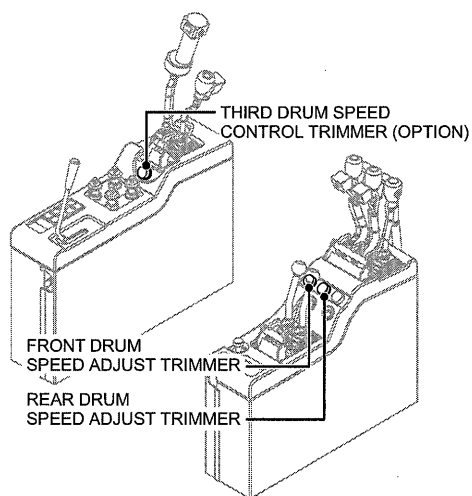

HOOK RAISING/LOWERING OPERATION**(1) RAISING**

Pull the drum control lever toward the raising side to hoist a load.

(2) LOWERING

Push the drum control lever forward to lower the load.

When the hook is not lowered by operating the drum control lever to the lowering side, it is possible that the lock is engaged in the ratchet of the drum.

In this case, slightly move the control lever to the raising side, then move to the lowering side again.

(3) STOPPING

When the drum control lever is returned to the neutral position, the automatic brake operates to stop the load.

CAUTION

When returning the control lever to the neutral, ensure that the lever is surely returned to the neutral position.

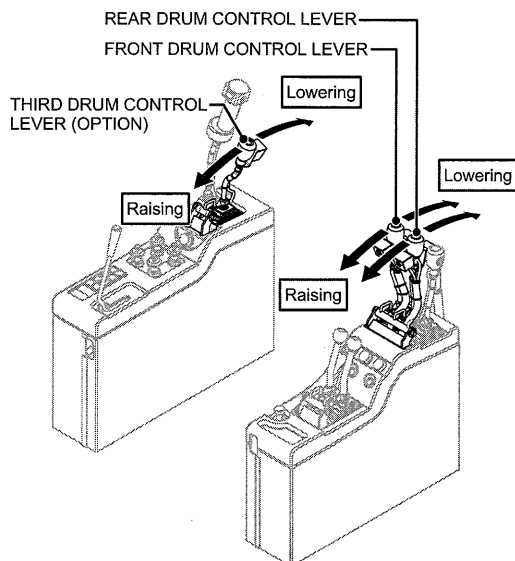

2

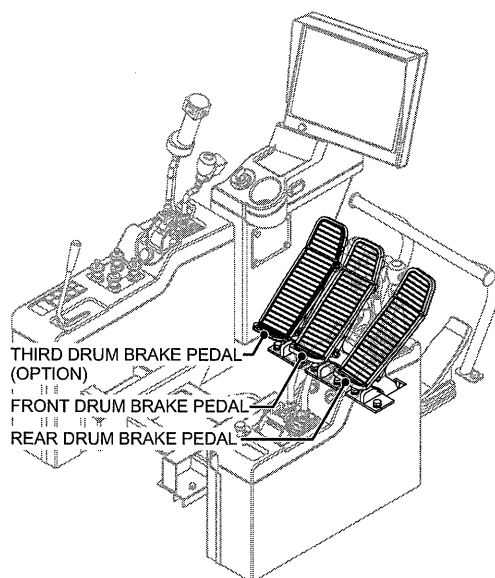
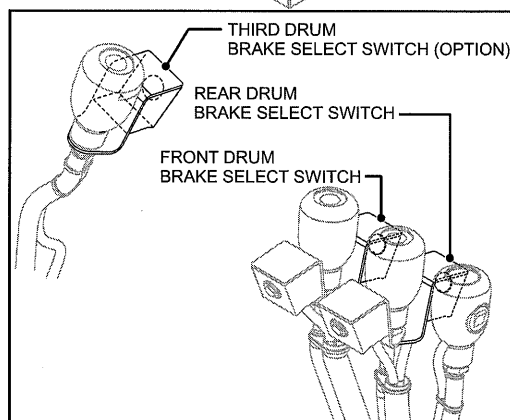

When the load is held in the air for a long time, engage the drum lock.

To engage the drum lock, fully pull the knob up.

The pulling resistance may vary but pull it fully.

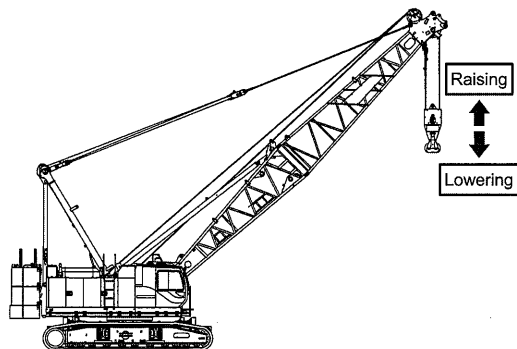

WARNING

Operate the control lever slowly. Abrupt control lever operation is very dangerous, and may create the shock to the main machinery or boom on load swinging.

WARNING

Even in case of neutral brake, engage the pedal lock of the brake pedal.

Note

In case of the brake with combination of brake pedal, neutral brake mode does not function. Whenever auto-stop occurs during hook raising or lowering, immediately return the control lever to neutral.

When the drum control lever is returned to the neutral, auto-brake actuates and the hook stops.

When the lifting load is to be held in the air for long time, engage the drum lock.

When the drum lock is to be engaged, pull the knob up completely. Although pull up resistance may change on its half way, pull up to the end.

Note

Simultaneous operation of the front drum with 1st speed and the rear drum with 2nd speed cannot be done due to hydraulic system.

G WINCH CONTROL

G winch is a function to bring maximum line speed with low engine speed at no load condition.

Control as per the following procedure.

CAUTION

G winch is not available with a load condition to prevent damage to the machine.

- Turn ON the G winch main switch located at the upper rear section of the cab.
After machine determines that the engine is at low idle and lever is in the neutral position, the yellow lamp in the monitor lights up.

G winch mode	G winch individual select switch located on the front and rear control levers becomes effective. * Detail is explained later.
Normal mode	G winch function is disabled.

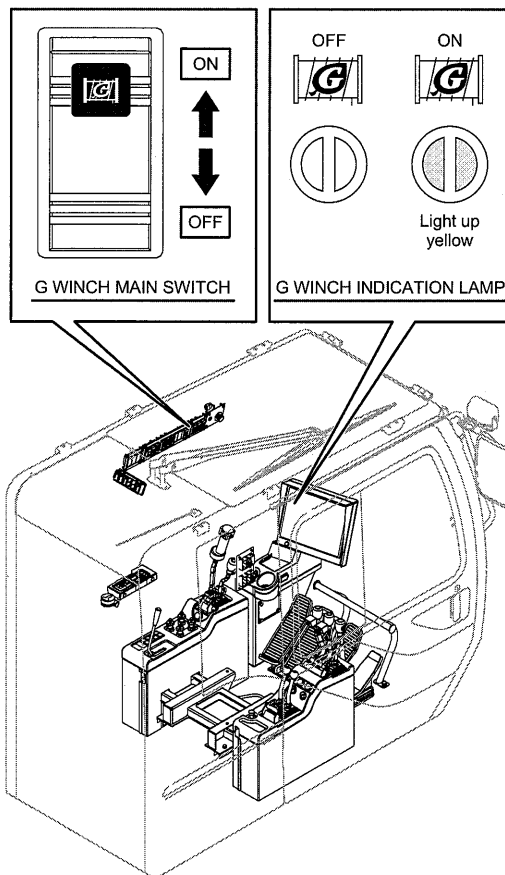

- (2) Turn ON the G winch individual switch.
 For the front and rear winches, by turning ON the individual select switch provided on the winch lever, G winch function becomes available.

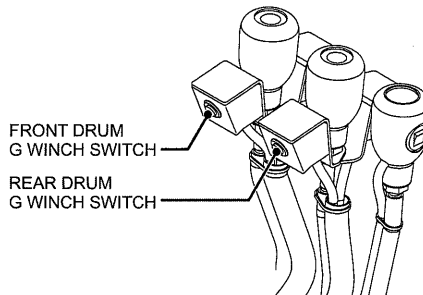

Work condition to enable G winch function.

- (A) G winch main switch is ON.
 (B) Engine is at low idle.
 (C) No lifting load.
 (D) Not in the soot burning (regenerate) condition.
 (Soot burning - regenerate lamp is OFF)
 (E) The control levers are in neutral position.
 (F) When condition (A) to (E) are met, press either front drum or rear drum individual select switch.
 The monitor symbol shown on right figure turns ON.

(a)	Front drum is in G winch mode (a side : green light ON)
(b)	Rear drum is in G winch mode (b side : green light ON)

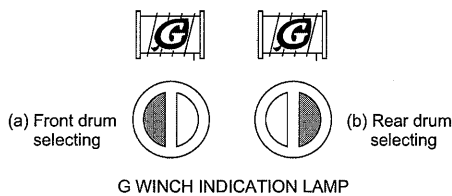

* Under green light ON condition, pressing the switch again can cancel the G winch mode.

CAUTION

Under the "G ENGINE MODE", when the normal winch mode is turned to G winch mode, engine speed is raised to 900 min⁻¹ (900 rpm).
 This is normal.

- (3) When the individual select lamp is turned ON, preparation is completed.
Operate each control lever.
High speed raising or lowering becomes possible.

After selecting the G winch individual, only one control can function as G winch mode.

When the lever is returned to the neutral function is cancelled. If the function has to be used again, push the individual select switch when the lever is in neutral.

CAUTION

In the lowering control, the initial speed may be slower in certain times.

This is caused by function of the counterbalance valve and is normal.

In case the front and rear drum speed adjusting trimmer are not in maximum position, maximum speed can not be obtained even under this function.

Ensure to the set them to maximum position.

- (4) When the following warning is issued, this function can not be used.

W-48	Actual revolution is higher than directive revolution.
------	--------------------------------------------------------

- * When the above warning is issued, safety lower the lifting load and turn OFF the key switch.
If the warning does not disappear after restart of the engine, contact KOBELCO service shop.

G ENGINE CONTROL

"G ENGINE" is a function to obtain the maximum line speed under no load at lower engine speed .

This is effective to save fuel consumption which otherwise is caused by unnecessary engine high speed.

CAUTION

Under G ENGINE condition, enough energy for heavy load work with high speed may not be obtained. Ensure to turn to power mode.

- (1) Turn on the G ENGINE switch located at the rear switch panel.
Green lamp in the main monitor lights up after lever is in neutral.
- (2) When any of the following warnings are issued, this function can not be used.
The engine returns to power mode automatically.

W-46	Qmax cut SOL output FB - abnormal.
W-47	Qmax cut SOL output abnormal.
W-48	Actual revolution is higher than directive revolution.

- * When the above warning is issued, safety lower the lifting load and turn OFF the key switch. If the warning does not disappear after restart of the engine, contact KOBELCO service shop.

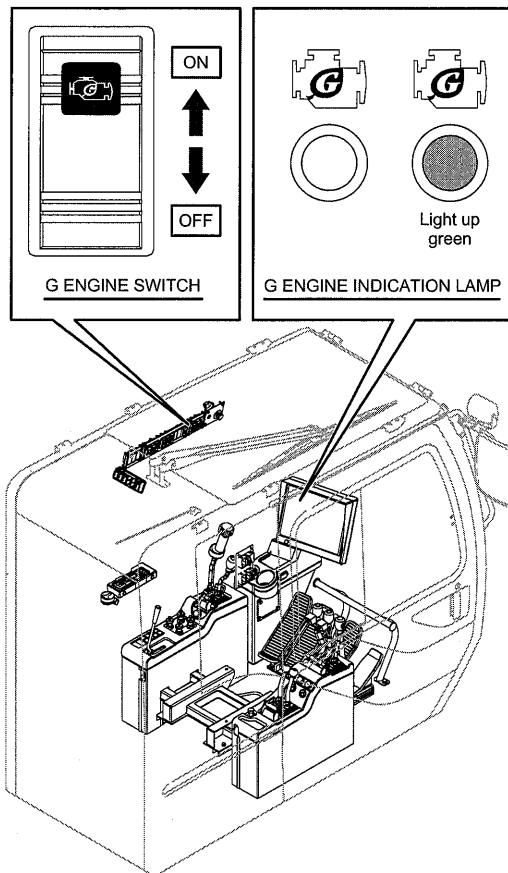

2.4 FREE FALL OPERATION (OPTION)

The use of the free fall must be limited to excavating operations with the bucket.

When lifting or lowering the bucket during the "FREE FALL" mode, be sure to follow the procedures.

⚠ DANGER

Perform the crane work with "NEUTRAL BRAKE" mode.

Crane work with "FREE FALL" mode may drop the load by operation error.

1. Set the "FREE FALL LOCK SWITCH" (with key in the left side stand) to the "Release" position.

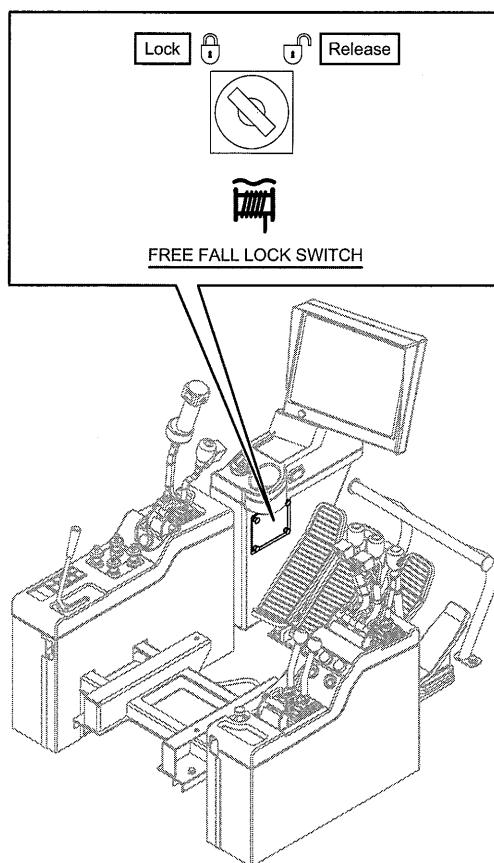

2. Set the control lever to the neutral position, and with the brake pedal depressed fully, push the brake selector switch at once.

The free fall indicator lamp in the monitor lights up to indicate that the brake is in the free fall condition.

At this condition, press the brake pedal at its heel portion to disengage the pedal lock and gradually release the brake pedal.

The lifting load starts lowering.

- When the brake pedal is depressed slightly, the pedal vibrates a little.

Depressing the pedal further from this point will actuate the brake.

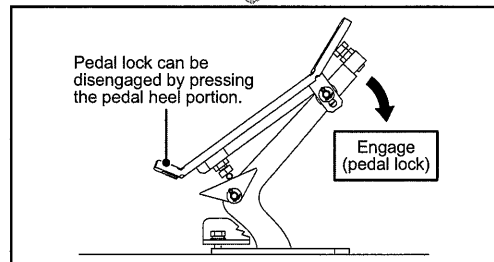
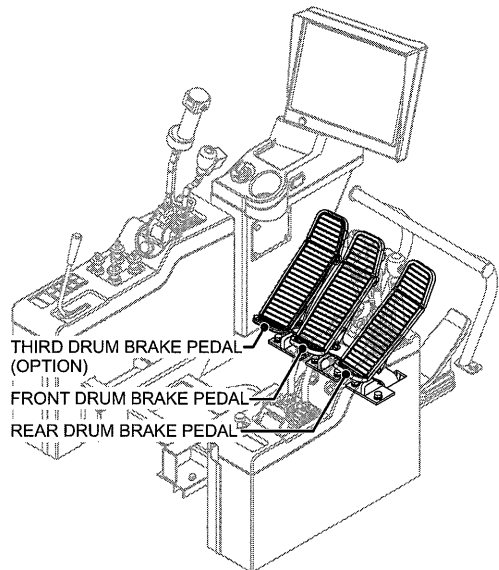
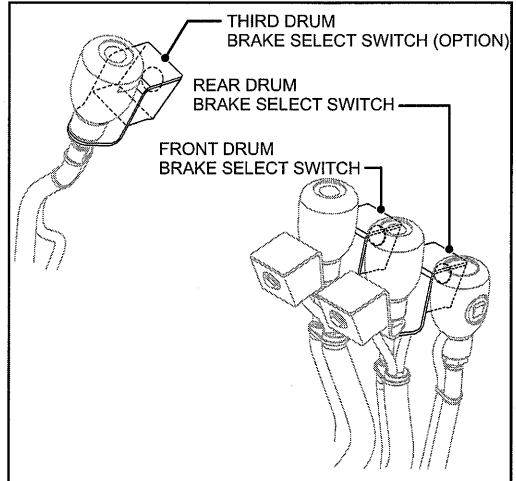

3. Free fall

- (1) Depress the brake pedal fully.
- (2) Return the drum control lever to the neutral position.
- (3) Slowly release the brake pedal to free fall the bucket.
- (4) Lowering speed is adjusted by adjusting pressure to the brake pedal.

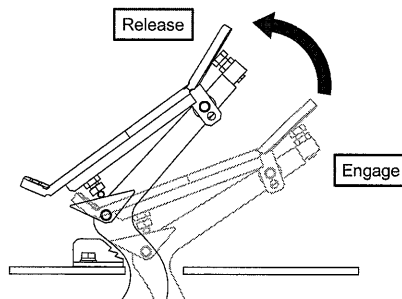
**CAUTION**

Do not apply abrupt brake during lowering a load with FREE FALLING.

Do not handle the drum lock control during lowering a load with FREE FALLING.

Do not push the drum brake select switch during lowering a load with FREE FALLING.

Do not control the lever during lowering a load with FREE FALLING.

If the free fall lowering speed is high, lifting load control may become difficult.

Use lower speed as much as possible.

4. Raising

Pulling the drum control lever backward, raising is possible even while the brake pedal remains depressed.

5. Lowering (Power lowering)

Pushing the drum control lever forward, lowering is possible even while the brake pedal remains depressed.

6. Stopping

Depress the brake pedal, and return the drum control lever to the "NEUTRAL" position.

The drum is stopped.

When the pressing amount is small, the brake pedal reacts with "KNOCKING".

In this case increase the pressing amount.

When the load is held in the air for a long time, press the drum brake select switch again to turn into the "NEUTRAL BRAKE" mode and engage the drum lock.

Ensure that the free fall indication lamp goes out.

 **CAUTION**

When the control lever is returned to neutral, the brake pedal must be depressed, otherwise the lifting load starts free falling.

If the load is heavy and pedal pressing amount is small, the load may still fall.

Therefore take extra care for "FREE FALL" mode operation.

In case of empty hook, if the free fall speed select switch is turned to speed increase (high) side, lowering speed is increased.

CAUTION

When changing the free fall speed select switch is in turned to increase side, do not release brake pedal with the hook on the ground.

The drum automatically rotates to lowering side and this may cause rough spooling.

While free falling the heavy load, do not change the free fall speed select switch.

A shock occurs at speed changing.

With the free falling, if auto-stop occurs due to load safety device or over-hoist preventive device, press the brake pedal first and then return the control lever to neutral position.

If the control lever is return to neutral before pressing the brake pedal, the lifting load may be dropped.

Take extra care on this.

Failure to observe these precautions may result in a serious accident.

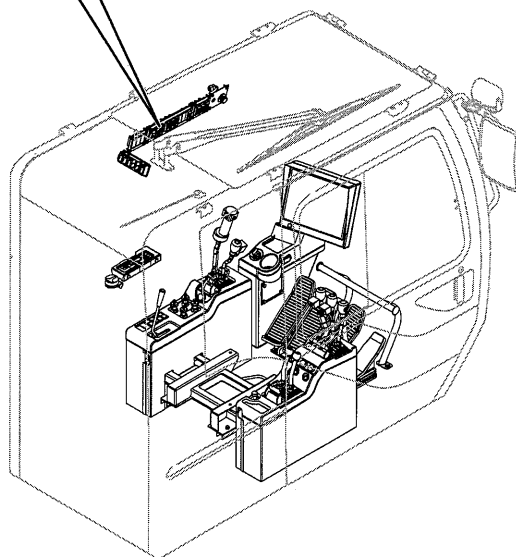
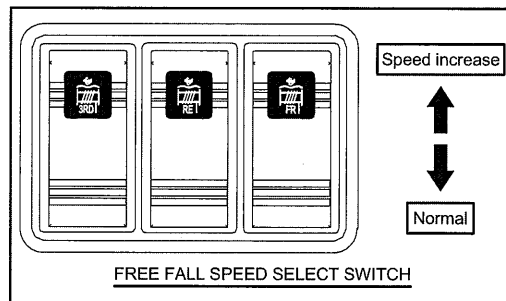

FREE FALL BRAKE MODE SWITCHING

	Brake → Free	Free → Brake
Function lock lever	Work position	Work position
Free fall lock switch	Release	Release
Drum control lever	Neutral	Neutral
Brake pedal	Depress	Depress
Brake select switch	Push (Once)	Push (Once)
Free lamp	Light up	Goes off
Mode	Free	Brake

7. Switching from "FREE FALL MODE" to "BRAKE MODE"

While the "FREE FALL MODE" is selected, set the drum control lever to the "NEUTRAL" position, and fully depress the brake pedal. Push the brake selector switch on the control lever again.

The free fall indicator lamp in the monitor goes off to indicate that the "BRAKE MODE" is selected.

The speed may be slow when the light bucket is lowered by free fall in the cold weather. In such cases, turn ON the "HYDRAULIC OIL HEAT CIRCUIT SELECT ICON". Produce an increase in the hydraulic oil temperature to a certain temperature.

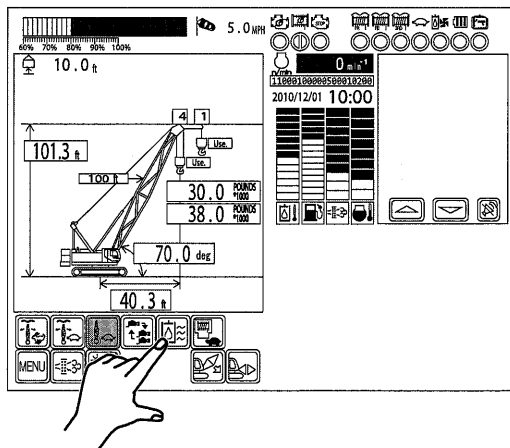

When the hydraulic oil has been replaced, the feeling of brake operation may change from the experience in the past.

In this case, consult our designated service shop.

When the messages as shown right are indicated on the cluster gauge during the operation, the free fall movement will be disabled.

Lower the lifting load and hook to the ground and turn OFF the key switch.

Power supply will be shut off about 90 seconds later.

Then, restart the engine and start the operation when the message indication disappeared.

If the messages as shown right are still indicated even if the engine has been restarted, stop the operation and contact our designated service shop.

SV MC1-W16

SV MC1-W17

SV MC1-W18

2

⚠ DANGER

When the error message is indicated, do not stop the engine with the load and hook held in the air. Failure to observe this caution, the load or the hook may fall.

2.5 CLAMSHELL OPERATION

In clamshell operation, the control levers and brake pedals are called with the designations shown in the following figure.

The basic control is as same as crane operation.

CAUTION

Since the clamshell needs repeating of bucket closing, raising, lowering or swing operation, it is likely that the damage to the hoist drum or boom, pin wear or missing or loosening bolts or missing occur.

Ensure to make pre-work or post work inspection surely.

CAUTION

After the work is completed, lower the bucket on the ground and press the closing or holding rope brake pedals and engage the pedal locks and turn to the brake mode and engage each drum lock and then engage the rotation lock on tagline drum after engine is stopped.

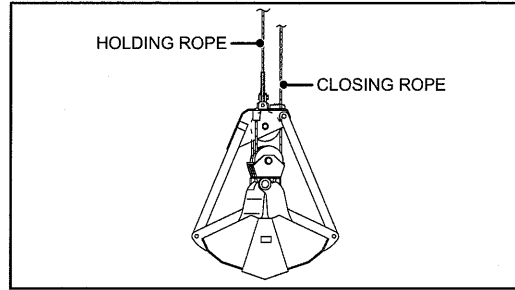

HOLDING ROPE DRUM BRAKE
SELECT SWITCH (REAR DRUM)
CLOSING ROPE DRUM BRAKE
SELECT SWITCH (FRONT DRUM)

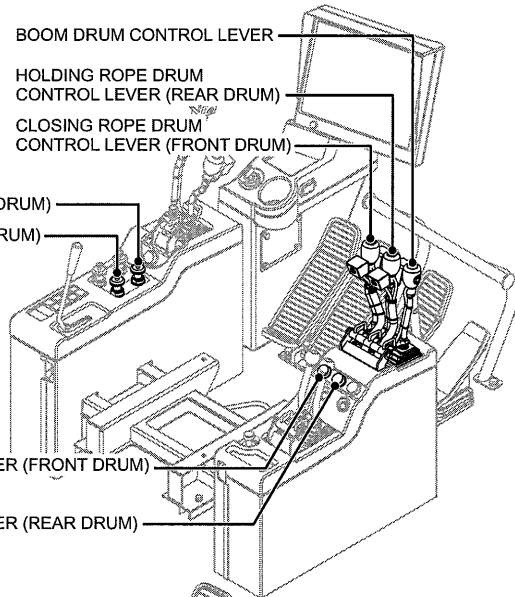
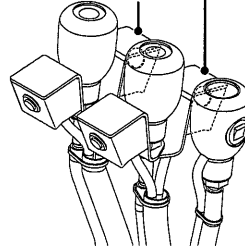

CLOSING ROPE DRUM
SPEED CONTROL TRIMMER (FRONT DRUM)
HOLDING ROPE DRUM
SPEED CONTROL TRIMMER (REAR DRUM)

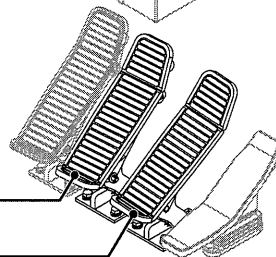

CLOSING ROPE DRUM
BRAKE PADEAL (FRONT DRUM)
HOLDING ROPE DRUM
BRAKE PADEAL (REAR DRUM)

2.5.1 PREPARATION WORK

1. Select the capacity of the clamshell bucket to meet the machine specification.
(Rated load, bucket weight, size)
2. Set the hydraulic tag line rope for bucket swing prevention to the bucket and check for its proper tension.
3. Set the drum speed adjusting trimmer to maximum.

Note

As for the drum speed adjusting trimmer, closing rope and holding rope would not be synchronized other than at maximum speed position.

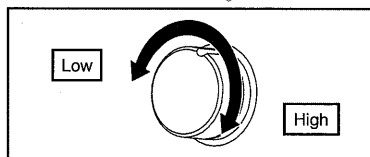
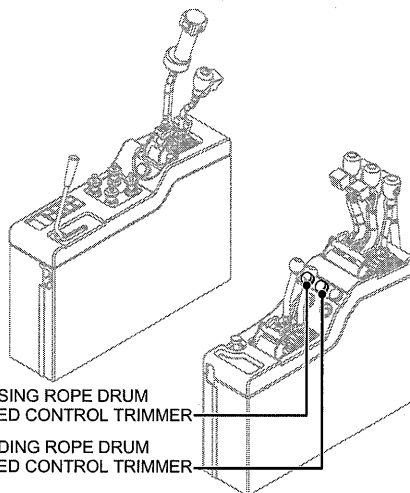

4. Turn the work mode select icon in the monitor to ON.

Note

In case of heavy load clamshell work, if the work mode select icon is in "OFF" (High speed) position, opening and closing rope may not be able to synchronize.

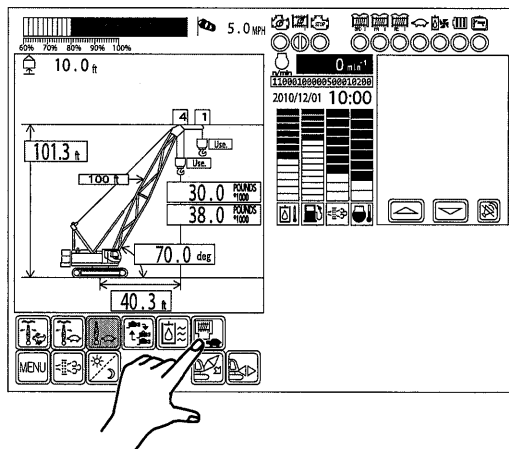

5. In case of bucket lowering of clamshell work with free fall mode, change to free fall mode refer to the article "FREE FALL OPERATION".
6. Turn the "FREE FALL LOCK SWITCH" (with key) on the left side stand to the "RELEASE" side.
7. Press both closing and holding brake pedals and push the drum brake select switch on each control lever to make both brakes to free fall conditions.
Confirm the free fall condition with the free fall indicating lamps on.
8. Adjust the engine speed with the accel grip.
9. If the clamshell rated load is programmed in the load safety device, it will function.

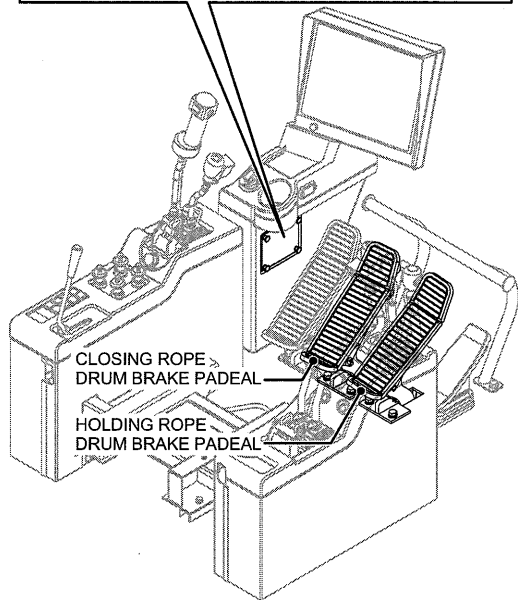
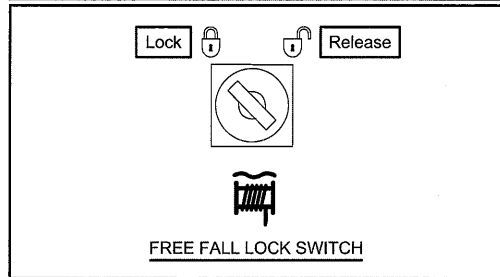
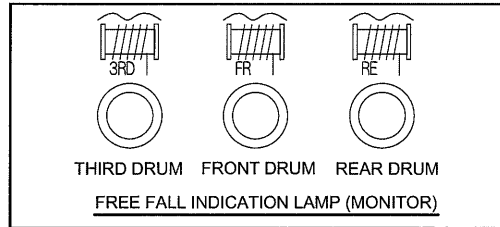

CAUTION

Take extra care not to cause overload in the clamshell work.
Set the load about 60% to 70% of the clamshell work rated load.
(Work at about 60% to 70% of the wire rope rated load.)
Do not shut off the load safety device at the clamshell work.
Work with the overload condition may cause damage on the boom or serious accident such as overturn of to the main machinery.

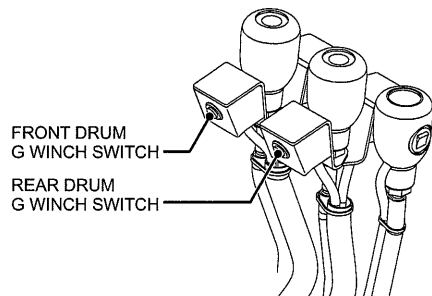
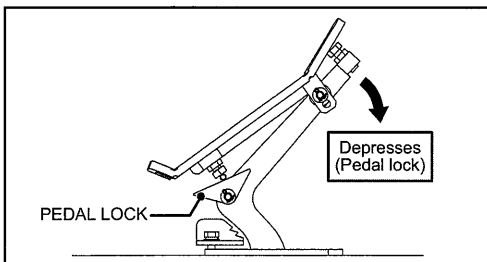

10. Setting of the controller of the load safety device.

- In case clamshell lifting capacity is specified.
This machine specifies clamshell lifting capacity.
When clamshell work has to be done, set it on the monitor screen as follows.

The setting items are a type of attachment and boom length.

Setting example

Attachment type	Clamshell
Boom length	18.3 m (60 ft)

Select in order from (1) to (3).

If input item is in error, press  icon to return to the previous screen.

Refer to the article 8 "CLAMSHELL RATED LOADS (OPTION)".

(1) Attachment select screen is displayed.

Select .

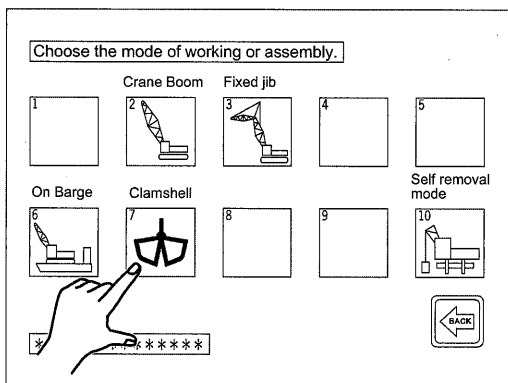

(2) Boom length select screen is displayed.

Select "60 feet".

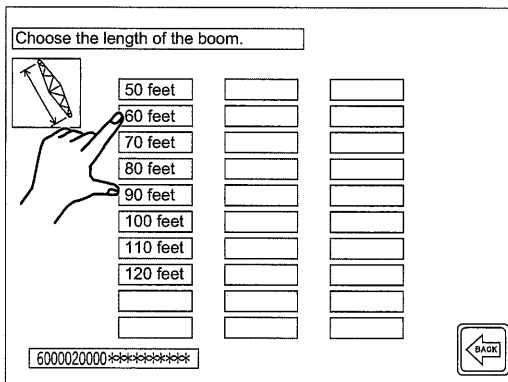

- (3) Press "0" in the number of part line setting.

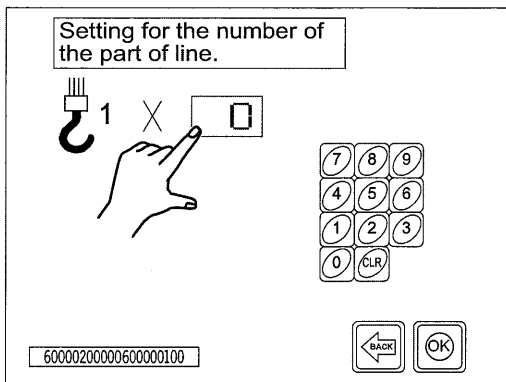

- (4) Press "1" by the number pad.

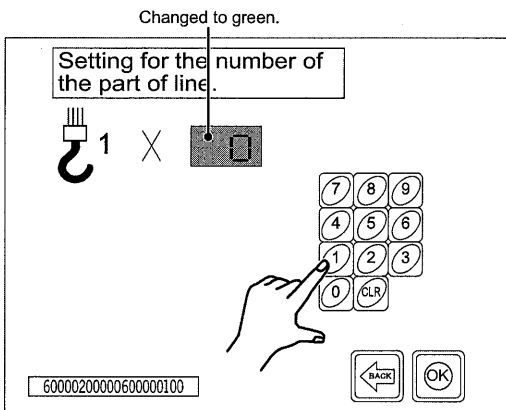

- (5) Press **OK**.
Setting is completed.

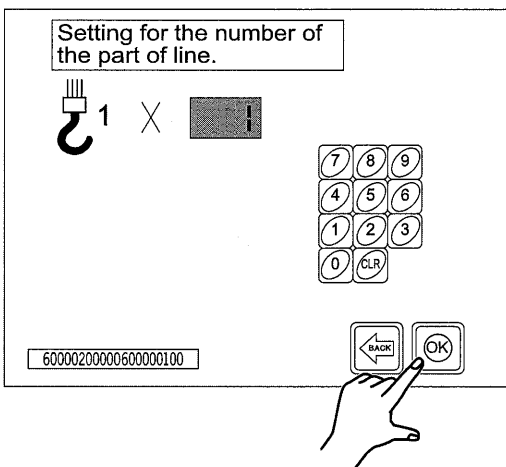

2.5.2 CLAMSHELL WORK



Total weight of bucket and material should not exceed the rated load.

The rated load is decided by machine stability and boom strength.

Never do abrupt acceleration or abrupt deceleration which may cause side load at swing work.

These may damage to the boom or guy line and is very dangerous.

2

CONTROL LEVER AND BRAKE PEDAL OPERATION IN CLAMSHELL WORK

Work condition	Closing rope		Holding rope		Control condition and caution
	Front drum control lever	Front drum brake pedal	Rear drum control lever	Rear drum brake pedal	
1. Digging material	Hoist	*Pedal released (Return)	Neutral (Free condition)	Half brake	Control the holding wire rope by rear drum brake and adjust the bucket to bite into material.
2. Hoist	Hoist	*Pedal released (Return)	Hoist	*Pedal released (Return)	Raise both closing wire rope and holding wire rope together to control not to allow one side loosening.
3. Stop	Neutral	Pedal pressed	Neutral	Pedal pressed	Stop bucket raising motion.
4. Swing	—	—	—	—	
5. Releasing material	Neutral	*Pedal released (Return)	Neutral	Pedal pressed	While swinging, release material and open bucket and keep opening.
6. Swing	—	—	—	—	Move bucket to digging position by swinging.
7. Lowering (Prepare for digging)	Neutral	(Half brake) or Pedal released	Neutral	(Half brake) or Pedal released	Lower bucket with half brake. Take care not to twist rope.

* Even brake pedal is pressed, raising motion is possible.

The above is one example of clamshell work.

According to the work condition, combination work is possible such as swinging with raising bucket and releasing material.

2.6 HANDLING OF HYDRAULIC TAGLINE (OPTION)

1. Stop the engine, and set the tagline tension adjusting trimmer to the lowest setting (fully turn to the left).
2. Remove the lock bolt from the drum flange and lock the bolt with nut.
3. Reeve the wire rope end through the outside of the drum flange, and fix it with a clamp.

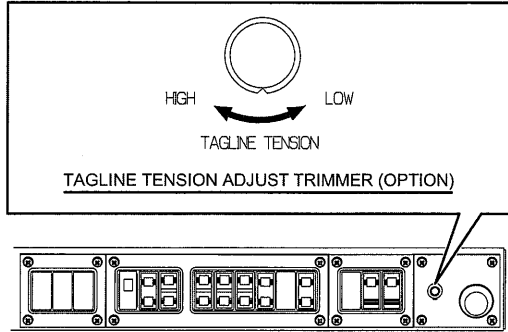

WARNING

Before starting the engine, ensure to turn the tagline tension adjust trimmer to the lowest tension minimum (turn left) and then start the engine.

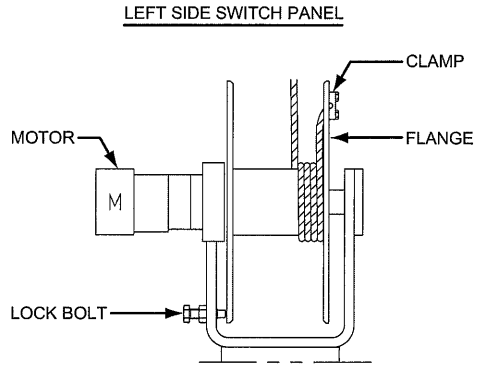

4. Set the other end of the wire rope to the bucket via the guide sheave.
5. Confirm that the tagline tension adjusting trimmer is at the lowest setting (fully turned to the left), and then start and idle the engine.

WARNING

Do not stand close to the drum or tagline wire rope since the tagline rope may be suddenly tensioned or slackened when starting or stopping the engine. Failure to observe this precaution may result in a serious injuries or loss of life.

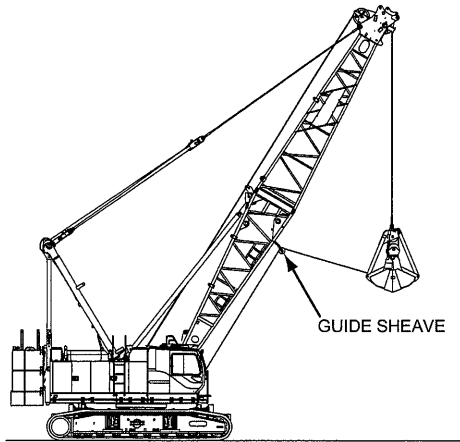

6. To wind up the rope on the drum, turn the tagline adjusting knob trimmer somewhat to the higher setting, while tensioning the wire rope.

⚠ WARNING

When the tag line rope is slacken, the winding motion suddenly starts by operating the tension adjusting switch.

Keep clear of the drum and tag line rope.

Make sure to turn the adjusting switch to the weakest position (turning fully counterclockwise) when you come close to the drum and tag line rope.

Failure to observe this precaution may result in a serious injuries or loss of life.

7. Adjust the wire rope tension with the tagline adjusting knob trimmer carefully.
Turn to the right : Tension increases.
Turn to the left : Tension decreases.

8. Turn the flow adjusting handle in case of winding speed needs to be changed.
Remove the swing motor cover to access the adjusting handle.

- **Turn clockwise (Right turn) :**
Winding speed decrease. (Flow decrease)
- **Turn counterclockwise (Left turn) :**
Winding speed increase. (Flow increase)

At the time of shipment, the flow adjusting handle set up at fully counterclockwise position (high speed side).

Note

When not using the tagline :

Fully wind up the wire rope on the drum, and fix the wire rope end.

Set the tension adjusting trimmer to the lowest setting (fully turn to the left).

Fix the drum flange with the lock bolt.

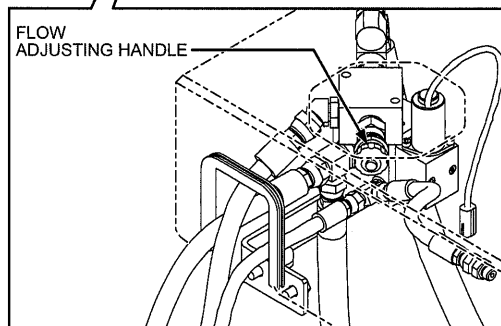
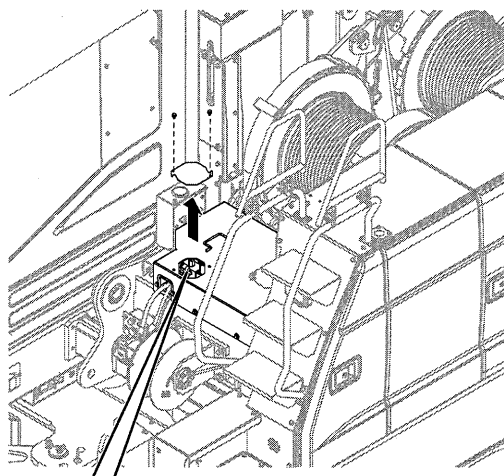

SPECIFICATION

		HYD. Tagline
Relief pressure	MPa (kgf/cm ²)	13.7 (140)
Wire rope type		FC 6 × W (19) Right-hand Regular lay
Breaking strength	kN (kgf)	57.9 (5.91)
Wire rope dia.	mm	10
Wire rope length	m (ft.)	45 (148)
Wire rope tension	kN (kgf)	1.67 (170)

2.7 HANDLING OF VIBRO HAMMER

1. Cautions when using

- (1) Be sure to use a vibro hammer within the rated load.

Total load indicated below must be within the crane rated load.

When driving a pile	Total load = (Hook weight + Pile weight + Vibro hammer weight)
When extracting a pile	Total load = (Hook weight + Pile weight + Vibro hammer weight + Centrifugal force [Vibration force] of vibro hammer × 1/4)

- (2) Use of lifting wire rope

Place a lifting wire rope between hook and vibro hammer so that the vibratory force of the vibro hammer is not transmitted directly to the hook.

2. Cautions when working

CAUTION

Do not turn the free fall speed select switch to speed crease side in vibro hammer work. Otherwise the hoist rope may cause rough spooling.

- (1) When starting operation

Place the vibro hammer on the head of the pile, and start with the winch wire rope loosened.

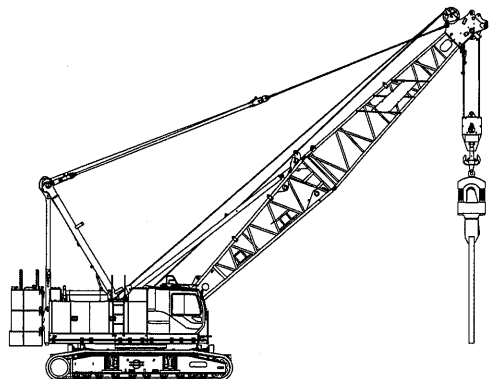

(2) While operating

 **CAUTION**

If the buffer spring is compressed completely, vibration of the vibro hammer would be transmitted directly to the boom through the wire rope and hook and damage may be caused.

Adjust the hook lowering speed so that the buffer springs is not tight compressed.

Do not operate the vibro hammer without a pile or pile lifted in the air.

 **DANGER**

While extracting the pile with the vibro and raising the load to the extent that the machine rear is lifted up intended to extract the pile with the machine rear lowering reaction may lead to severe impact to the various portion of the machine.

Never attempt to operate such overload work in the vibro work.

Failure to observe this precaution may result in a serious accident.

(3) When stopping operation

In order to minimize resonance generated when stopping, place the vibro hammer on the head of the pile, and stop operation.

3. Check and maintenance

Since larger loads and vibrations are generated repeatedly in a short time in vibro hammer operation and damage to the boom and hook, etc. and looseness of screws are likely to occur. Be sure to check carefully before and after operation.

If any abnormality is found, immediately repair or replace.

Consult the KOBELCO service shop for disassembly inspection of the hook (Dye penetrant check).

Check for looseness or missing of the counterweight nuts every 5 months.

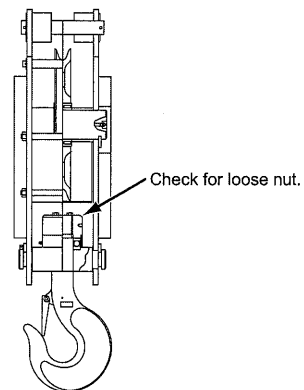

2

CAUTION

The warranty does not cover any damage to the equipment caused by failure to follow operating instructions and cautions described above.

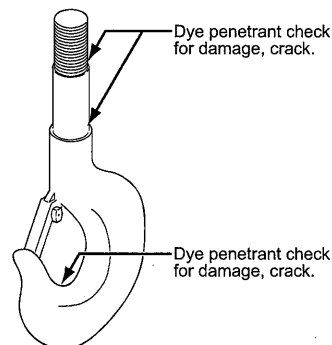

2.8 HANDLING OF REEVING WINCH (OPTION)

Use the reeving winch when the hoist wire rope is to be reeved on the hook.

The reeving winch is used to reeve the wire rope which has been wound on the hoist drum through the boom point sheave and to the hook sheave.

CAUTION

Do not use the reeving winch for other purpose than mentioned below.

Reeving work of hoist wire rope between boom point sheave and hook sheave during assembly work

SPECIFICATION

		HYD. Tagline
Relief pressure	MPa (kgf/cm ²)	12.7 (130)
Wire rope type		FC 6 × W (19) Right-hand Regular lay
Breaking strength	kN (kgf)	37 (3.78)
Wire rope dia.	mm	8
Wire rope length	m (ft.)	260 (853)
Wire rope tension	kN (kgf)	6.54 (667)

2.8.1 PREPARATION BEFORE HANDLING REEVING WINCH

CAUTION

- Use hand protection such as leather glove to avoid injuries when handling the wire rope.
- Take extra care for moving wire rope to avoid an accident of being caught or entanglement.

Failure to observe these precautions may result in a serious injury or loss of life.

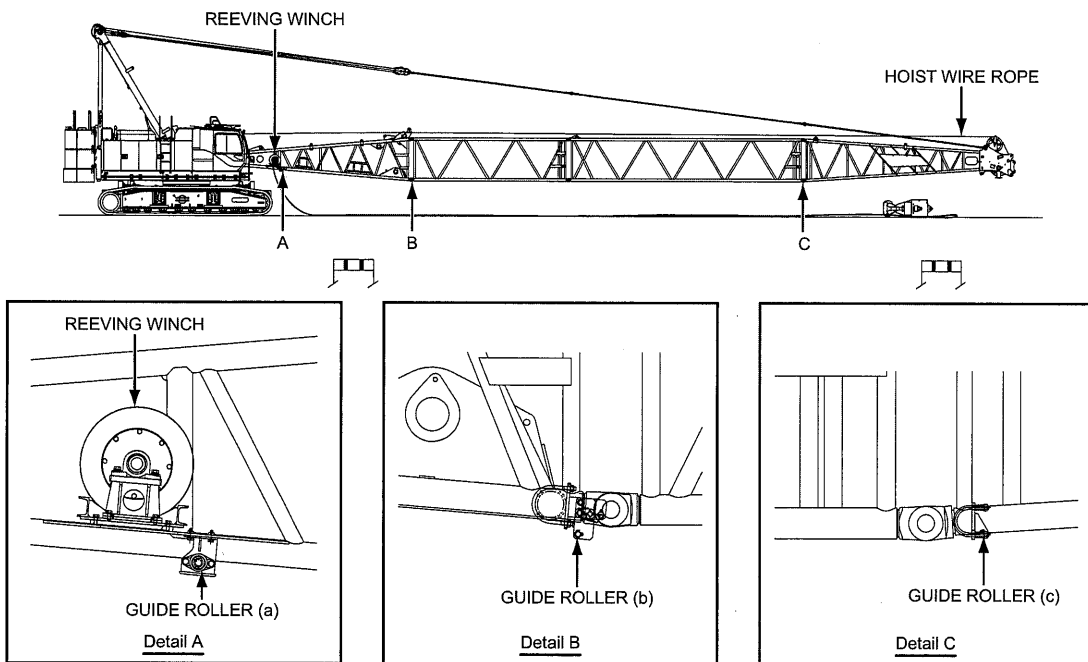

1. Set the boom in horizontal condition.
2. Place the hook to be used near the boom point. Put the hook down on the ground, since a standing hook may fall.
3. Take out the roller of the guide roller (b) to the work positions and secure with the lock pin.

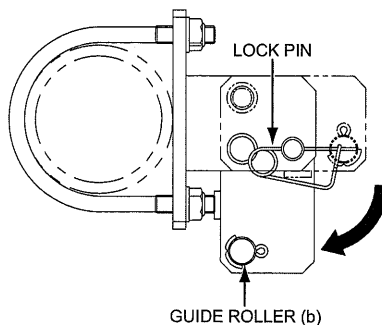

4. Connect the hoses from the reeving winch control valve to the valve block (d) on the boom base left side with each hose coupler (e), (f), (g). Connect each hose coupler so that the male and female fitting of the valve block (d) matches each other.

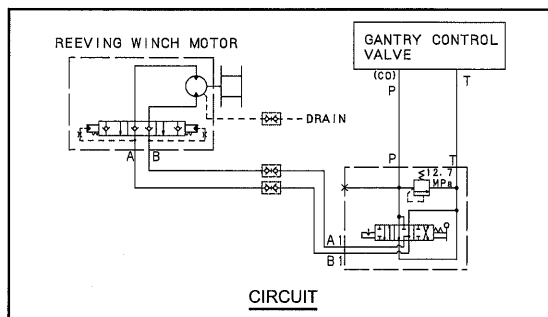
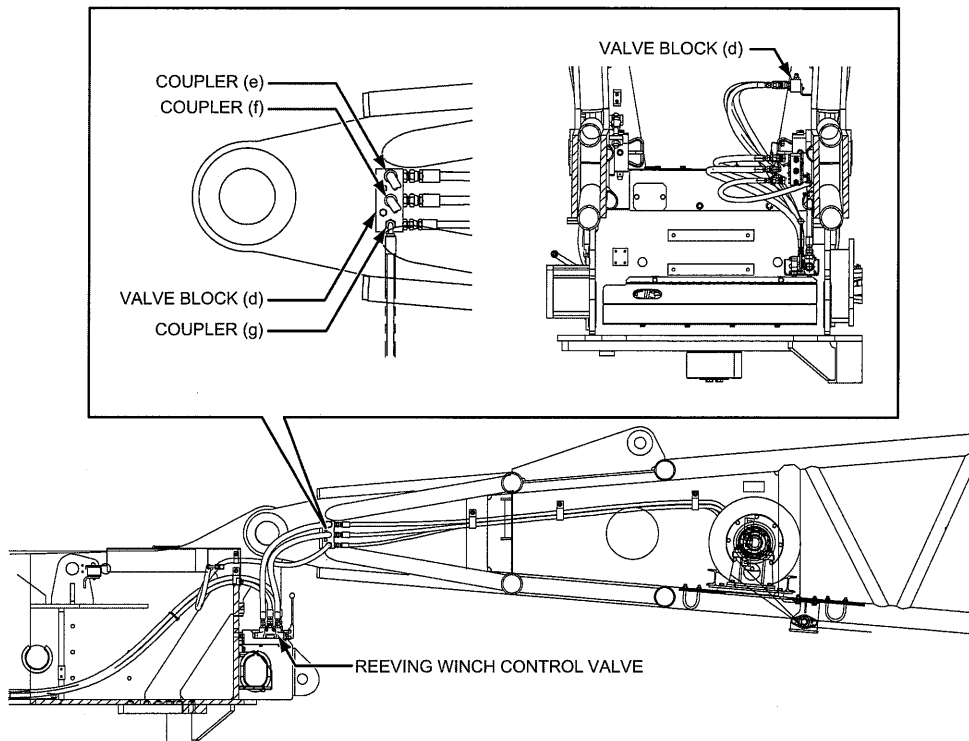

2.8.2 HANDLING PROCEDURE OF REEVING WINCH

Reeving of hoist wire rope between the boom point sheave and the hook sheave is explained here.

1. Start the engine and set to idling (800 min⁻¹ [800 rpm]).
2. Pay out the hoist wire rope to be reeved between the boom point and the hook to around the top boom idler sheave area.

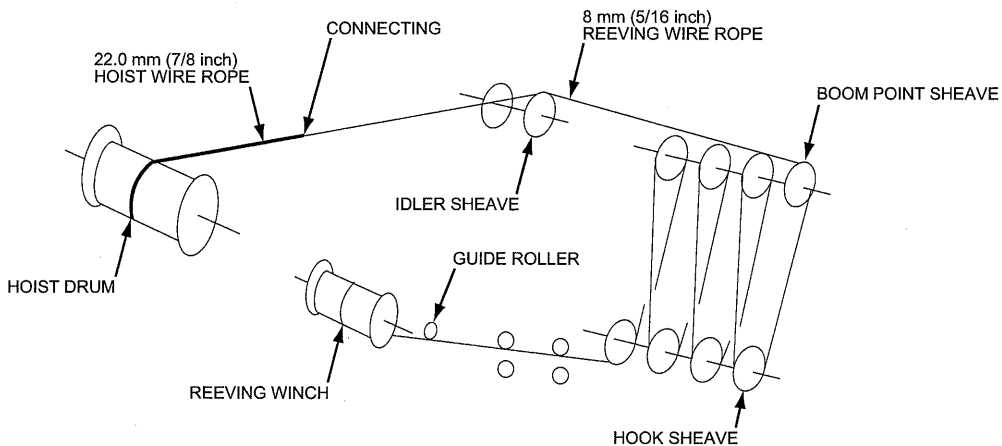

3. Turn the reeving winch control lever to pay out side and pay out the reeving winch wire rope from the boom foot to the boom point area. In this case, pay out the reeving winch wire rope for some extra length for part line of the hoist wire rope.

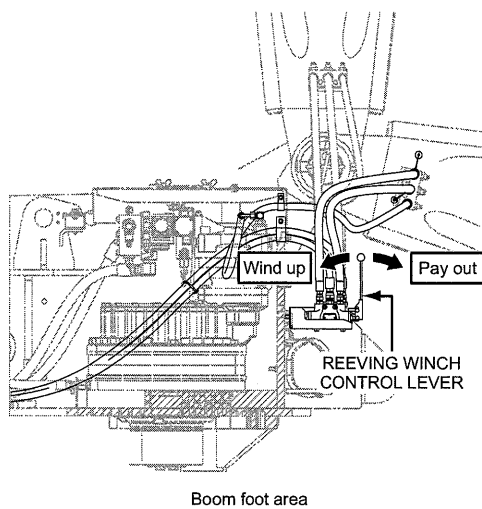

4. Reeving wire rope shall be through the point sheave and hook sheave from the opposite side of the hoist wire rope.

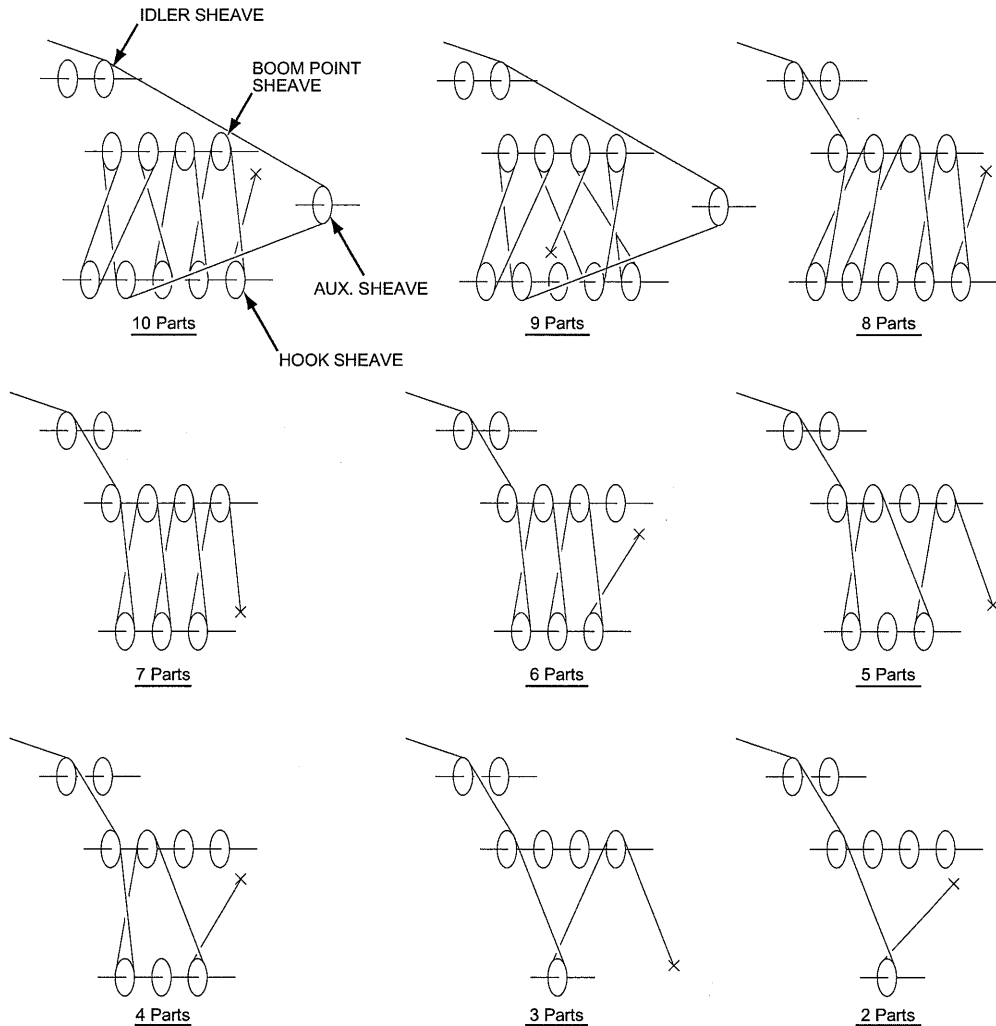

(This figure is view from the boom tip side.)

5. Connect the hoist wire rope and the reeving wire rope between the point sheave and the idler sheave or before passing through the idler sheave.

If the rope joint as shown right is used to connect both wire ropes, disconnection after reeving would be easier.

Push in both hoist wire rope and the reeving wire rope fully and draw through the wire ropes by hand for a few times to stretch the joint area. Secure both ends with the steel wire tightly to connect the hoist wire rope and the reeving wire rope.

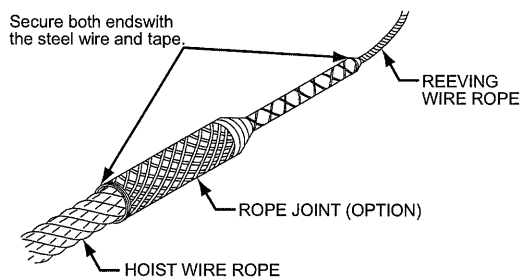

2

CAUTION

- Use rope joint commercially available in the market. (Do not use a hand made one)
- Do not use the rope joint damaged in the joint area.
- If the insertion into the rope joint is not enough, wire rope may slip out. Insert firmly and secure with the steel wire tightly.

Failure to observe these precautions may result in serious accident.

6. Turn the reeving winch control lever slowly to the wind up side and take up the reeving wire rope slack around the boom lower face and between both sheaves.
7. Then by turning the hoist wire rope drum control lever to lowering side and setting the lowering side to free fall and slowly turn the reeving winch control lever to wind up side to wind up the hoist wire rope between both sheaves.

At this time, make sure that the reeving wire rope runs under the guide rollers (a), (b), (c) of the boom lower face and not interfering with the boom lattice pipe.

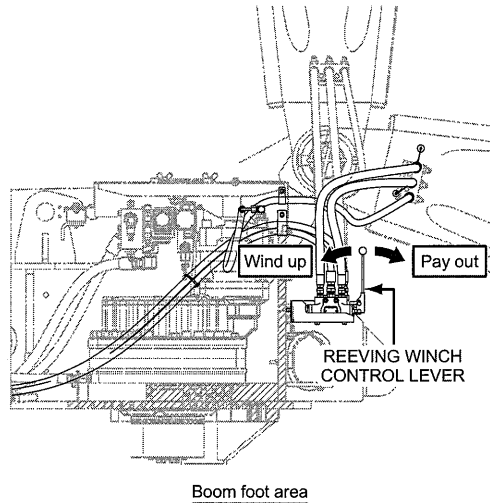

⚠ CAUTION

Proceed on winding up work without applying tension on both wire ropes.

If both wire ropes are tensioned, rope joint may break or the boom may be damaged.

Failure to observe this precaution may result in serious accident.

8. When the winding up work of the hoist wire rope is completed, stop the hoist drum and return the reeving winch control lever to neutral.
9. Disconnect the rope joint and wind up the paid out reeving winch wire rope completely to the drum of the reeving winch. Secure the reeving wire rope to the drum with the steel wire.

10. Pass the hook over-hoist limit switch weight through the hoist rope end and attach the rope socket to the hoist rope end and secure them to the boom point area with the bolts , nuts and the splits pins.
Open the split pins to approx. 60 degrees.
11. Return the guide roller (b) installed on the boom base to the stowed position and secure with the lock pins.

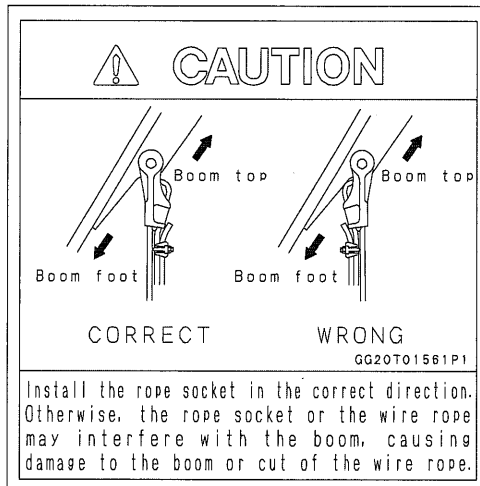

2

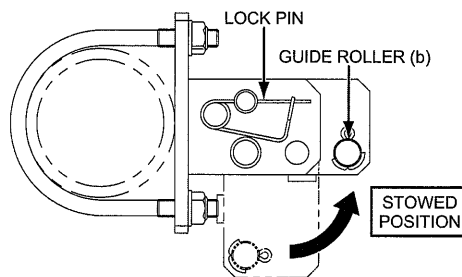

2.9 OPERATION IN WEATHER CHANGE AND SPECIAL CIRCUMSTANCE

This article explains countermeasures in operation when strong wind, lightning, electric shock or radio wave interference occurs.

2.9.1 CAUTION AGAINST WIND

DANGER

Lifting load swinging due to strong wind may lead to serious accident such as overturn of the machine.

Strictly observe the following precautions to prevent accident.

Failure to observe these precautions may lead to a serious accident, injuries or loss of life.

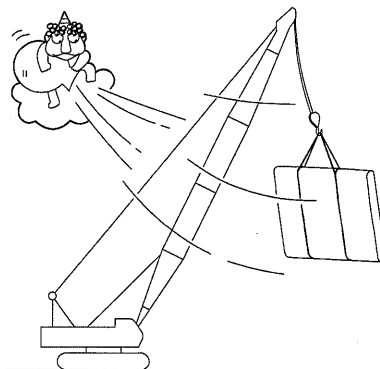

1. Influence of wind

Influence of the wind on the machine becomes larger in proportion to the size of a lifted load, lifting height, and boom length.

The following conditions are very dangerous, so utmost care is necessary for operation.

- (1) When lifting a load of with large surface area, against which the wind blows hard, the wind could cause the overturn of the machine and damage to the boom.

The wind could also blow the load against the boom, and could cause damage.

- (2) When the boom is fully raised without a load, the wind could blow the boom backward resulting in an overturn of the machine.

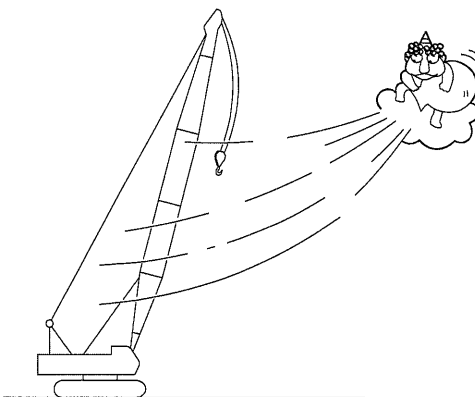

2. Cautions for wind

When performing crane operation in strong wind, utmost cautions are required according to the wind speed, machine condition and working environment.

The wind speed is different on the ground than in the high air.

It is also different on open area and populated area.

Always consider these conditions and take proper measures to meet the situation.

The wind speed mentioned here means the instantaneous wind speed.

When the wind speed exceeds 9.8 m/s (22 MPH) stop the work.

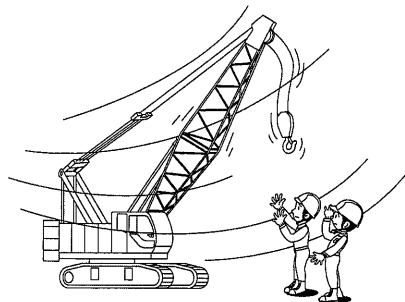

2

3. Method of wind speed measurement

- (1) If an instantaneous anemometer is provided in the machine, measure the wind speed with the anemometer provided.
- (2) If an instantaneous anemometer is not provided in the machine, the wind speed given by a weather report can be converted to the instantaneous wind speed based on convention chart in P.2-136.
- (3) The instantaneous wind speed can be approximated by the Beaufort chart (refer to P.2-136).

The position where the wind works against the machine is the height above the ground.

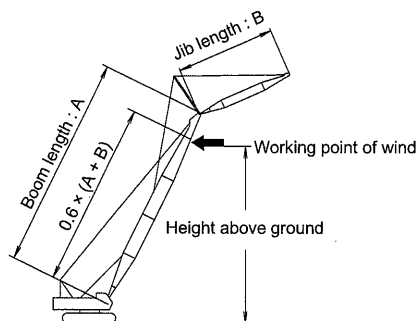
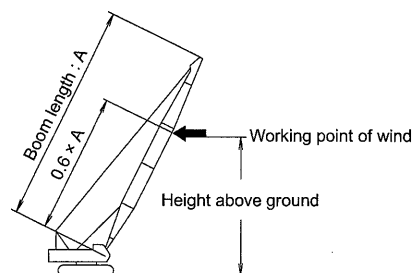

[2. OPERATION]

Wind speed in the weather report is average wind speed in 10 minutes.

This must be converted into instantaneous wind speed.

CONVERSION TABLE OF WIND SPEED

Unit : m/s (MPH)

Height above ground : m (ft.)	Wind speed 3 m/s (6.7 MPH)				Wind speed 5 m/s (11.2 MPH)				Wind speed 8 m/s (17.9 MPH)				Wind speed 10 m/s (22.4 MPH)			
	Flat area		City area		Flat area		City area		Flat area		City area		Flat area		City area	
	Av.	Inst.	Av.	Inst.	Av.	Inst.	Av.	Inst.	Av.	Inst.	Av.	Inst.	Av.	Inst.	Av.	Inst.
5 (17)	2.7 (6.0)	9.8 (21.9)	2.5 (5.6)	10.0 (22.4)	4.5 (10.0)	11.7 (26.2)	4.2 (9.4)	11.4 (25.5)	7.1 (15.9)	14.5 (32.4)	6.7 (15.0)	14.0 (31.3)	8.9 (19.9)	16.3 (36.5)	8.4 (18.8)	15.8 (35.3)
10 (33)	3.0 (6.7)	10.2 (22.8)	3.0 (6.7)	10.2 (22.8)	5.0 (11.2)	12.3 (27.5)	5.0 (11.2)	12.3 (27.5)	8.0 (17.9)	15.4 (34.4)	8.0 (17.9)	15.4 (34.4)	10.0 (22.4)	17.5 (39.1)	10.0 (22.4)	17.5 (39.1)
15 (50)	3.2 (7.2)	10.4 (23.3)	3.3 (7.4)	10.5 (23.5)	5.4 (12.1)	12.7 (28.4)	5.6 (12.5)	12.9 (28.9)	8.6 (19.2)	16.0 (35.8)	8.9 (19.9)	16.3 (36.5)	10.7 (23.9)	18.2 (40.7)	11.1 (24.8)	18.7 (41.8)
20 (66)	3.4 (7.6)	10.5 (23.5)	3.6 (8.0)	10.8 (24.2)	5.6 (12.5)	12.9 (28.9)	6.0 (13.4)	13.3 (29.8)	9.0 (20.1)	16.5 (36.9)	9.5 (21.3)	17.0 (38.0)	11.2 (25.0)	18.8 (42.1)	11.9 (26.6)	19.5 (43.6)
25 (82)	3.5 (7.8)	10.7 (23.9)	3.8 (8.5)	11.0 (24.6)	5.9 (13.2)	13.2 (29.5)	6.3 (14.1)	13.6 (30.4)	9.4 (21.0)	16.9 (37.8)	10.1 (22.6)	17.6 (39.4)	11.7 (26.2)	19.3 (43.2)	12.6 (28.2)	20.2 (45.2)
30 (99)	3.6 (8.0)	10.8 (24.2)	4.0 (8.9)	11.2 (25.0)	6.0 (13.4)	13.3 (29.8)	6.6 (14.8)	13.9 (31.1)	9.6 (21.5)	17.1 (38.3)	10.6 (23.7)	18.1 (40.5)	12.0 (26.8)	19.6 (43.8)	13.2 (29.5)	20.9 (46.8)
40 (132)	3.8 (8.5)	11.0 (24.6)	4.2 (9.4)	11.5 (25.7)	6.3 (14.1)	13.6 (30.4)	7.1 (15.9)	14.5 (32.4)	10.1 (22.6)	17.6 (39.4)	11.3 (25.3)	18.9 (42.3)	12.6 (28.2)	20.2 (45.2)	14.1 (31.5)	21.8 (48.8)
50 (164)	3.9 (8.7)	11.1 (24.8)	4.5 (10.0)	11.7 (26.2)	6.6 (14.8)	13.9 (31.1)	7.5 (16.8)	14.9 (33.3)	10.5 (23.5)	18.0 (40.3)	12.0 (26.8)	19.6 (43.8)	13.1 (29.3)	20.8 (46.5)	15.0 (33.6)	22.8 (51.0)
75 (260)	4.2 (9.4)	11.4 (25.5)	5.0 (11.2)	12.2 (27.3)	7.0 (15.7)	14.4 (32.2)	8.3 (18.6)	15.7 (35.1)	11.2 (25.0)	18.8 (42.1)	13.2 (29.5)	20.9 (46.8)	14.0 (31.3)	21.7 (48.5)	16.5 (36.9)	24.8 (55.5)
100 (328)	4.4 (9.8)	11.6 (25.9)	5.3 (11.9)	12.6 (28.2)	7.4 (16.6)	14.8 (33.1)	8.9 (19.9)	16.3 (36.5)	11.8 (26.4)	19.4 (43.4)	14.2 (31.8)	21.9 (49.0)	14.7 (32.9)	22.4 (50.1)	17.8 (39.8)	26.7 (59.7)

* Wind speed may be higher than the above value near tall buildings.

BEAUFORT WIND SCALE CHART

Unit : m/s (MPH)

Approximate wind speed at 10 m (33 ft) height from the open and flat ground	Details
Less than 0.3 (0.7)	Calm, smoke rises vertically.
0.3 (0.7) to less than 1.6 (3.6)	Smoke drift indicates wind direction, still wind vanes.
1.6 (3.6) to less than 3.4 (7.6)	Wind felt on face, leaves rustle, vanes begin to move.
3.4 (7.6) to less than 5.5 (12.3)	Leaves and small twigs constantly moving, light flags extended.
5.5 (12.3) to less than 8.0 (17.9)	Dust, leaves, and loose paper lifted, twigs move.
8.0 (17.9) to less than 10.8 (24.2)	Many whitecaps, leaf in small trees begin to sway.
10.8 (24.2) to less than 13.9 (31.1)	Larger tree branches moving, whistling in wires, hard to walk under an umbrella.
13.9 (31.1) to less than 17.2 (38.5)	Whole trees moving, resistance felt walking against wind.
17.2 (38.5) to less than 20.8 (46.5)	Twigs broken, cannot walk against wind.
20.8 (46.5) to less than 24.5 (54.8)	Slight structural damage occurs, chimney broken, slate blows off roofs.
24.5 (54.8) to less than 28.5 (63.8)	Seldom experienced on land, trees broken or uprooted, and considerable structural damage.
28.5 (63.8) to less than 32.7 (73.1)	Scarcely experienced, damages occur in wide areas.
32.7 (73.1) or more	

COUNTERMEASURE AGAINST WIND (CRANE)

Take the following actions based on wind speed at work area.

Take the same action in case the strong wind is expected after work.

The wind speed here means "Instantaneous wind speed".

- **In case the wind speed is 9.8 to 15.6 m/s (22 to 35 MPH), stop the work and take the following actions.**

1. Lower the load on the ground and remove it from the hook.
2. Set the boom angle to approx. 60 degrees.
3. Swing the machine to receive the wind at the counterweight side.
(Receive the wind at the back face of the boom.)
4. Lock the winches, apply swing brake, and stop the engine.

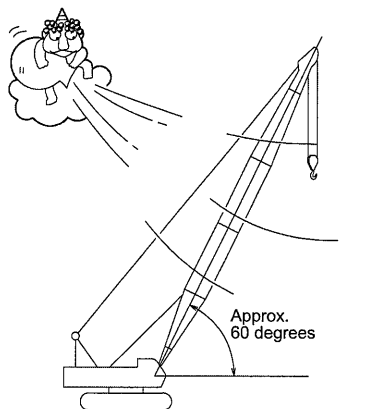

- **In case wind speed is higher than 15.6 m/s (35 MPH), lower the boom on the ground taking the following actions.**

1. In case when the wind speed is 15.6 to 30.0 m/s (35 to 67 MPH) and the attachment can be lowered on the ground.
 - (1) Lower the load on the ground and remove it from the hook.
 - (2) Lower the boom on the ground.
If swing is necessary, swing with approx. 60 degrees boom angle.
 - (3) Lock the winches, apply swing brake, and stop the engine.

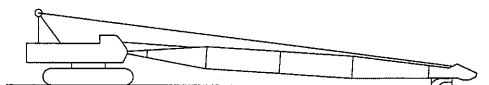

2. In case when the wind speed is 9.8 to 30.0 m/s (22 to 67 MPH) and the attachment can not be lowered on the ground, take the following actions with the emergency anchor weight prepared as shown below.

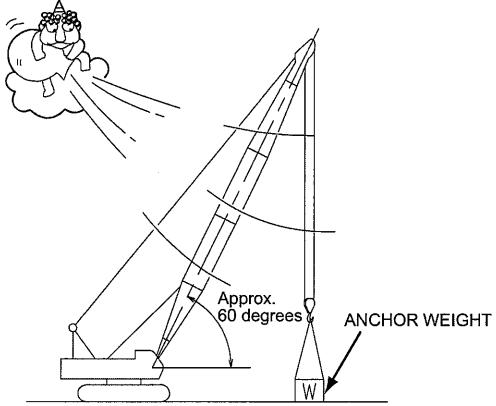

- (1) Lower the load on the ground and remove it from the hook.
- (2) Set the boom angle to approx. 60 degrees.
- (3) Swing the machine to receive the wind at the counterweight side.
(Receive the wind at the back face of the boom.)
- (4) Connect the hook to the anchor weight and apply tension the hoist rope.
- (5) Lock the winches, apply swing brake, and stop the engine.

CRANE ANCHOR WEIGHT

Boom length : m (ft.)	Boom angle : degrees	Anchor weight : t (lbs)
15.2 to 27.4 (50 to 90)	60	—
30.5 to 42.7 (100 to 140)		0.8 (1,800)
45.7 to 61.0 (150 to 200)		2.6 (5,800)
64.0 to 70.1 (210 to 230)		3.6 (8,000)

- **In case wind speed is higher than 30.0 m/s (67 MPH).**

Ensure to lower the attachment on the ground as per the previously mentioned procedure.

COUNTERMEASURE AGAINST WIND (WITH JIB)

Prepare the anchor weight as shown below.

1. Lower the load on the ground and remove it from the hook.
2. Set the boom angle to approx. 60 degrees.
3. Swing the machine to receive the wind at the counterweight side.
(Receive the wind at the back face of the boom.)
4. Connect the hook to the anchor weight and apply tension to the hoist rope.

ANCHOR WEIGHT (WITH JIB)

Jib length : m (ft.)	Boom length : m (ft.)	Boom angle : degrees	Anchor weight : t (lbs)	
			Offset angle 10 degrees	Offset angle 30 degrees
9.1 and 12.2 (30 and 40)	27.4 to 36.6 (90 to 120)	60	1.7 (3,800)	1.1 (2,500)
	39.8 to 51.8 (130 to 170)		3.6 (8,000)	2.9 (6,500)
	54.9 to 61.0 (180 to 200)		5.2 (12,000)	4.2 (9,300)
12.2 and 15.2 (40 and 50)	27.4 to 36.6 (90 to 120)		1.8 (4,000)	1.0 (2,300)
	39.8 to 51.8 (130 to 170)		3.7 (8,200)	2.6 (5,800)
	54.9 to 61.0 (180 to 200)		5.3 (12,000)	3.8 (8,400)
18.3 and 21.3 (60 and 70)	27.4 to 36.6 (90 to 120)		2.0 (4,500)	0.9 (2,000)
	39.8 to 51.8 (130 to 170)		3.8 (8,400)	2.4 (5,300)
	54.9 to 61.0 (180 to 200)		5.5 (13,000)	3.5 (7,800)

5. Lock the winches, apply swing brake, and stop the engine.

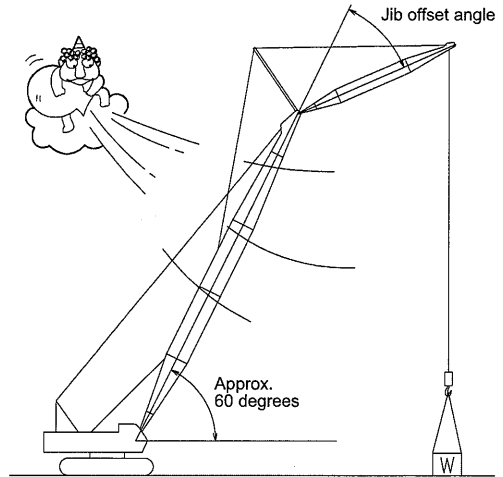

- **In case when the wind speed is expected to exceed 30.0 m/s (67 MPH).**

Lower the boom on the ground in advance.

Tip

This shows the wind speed increase when raising the boom.

Wind effect becomes larger with longer boom length or larger boom angle.

CRANE

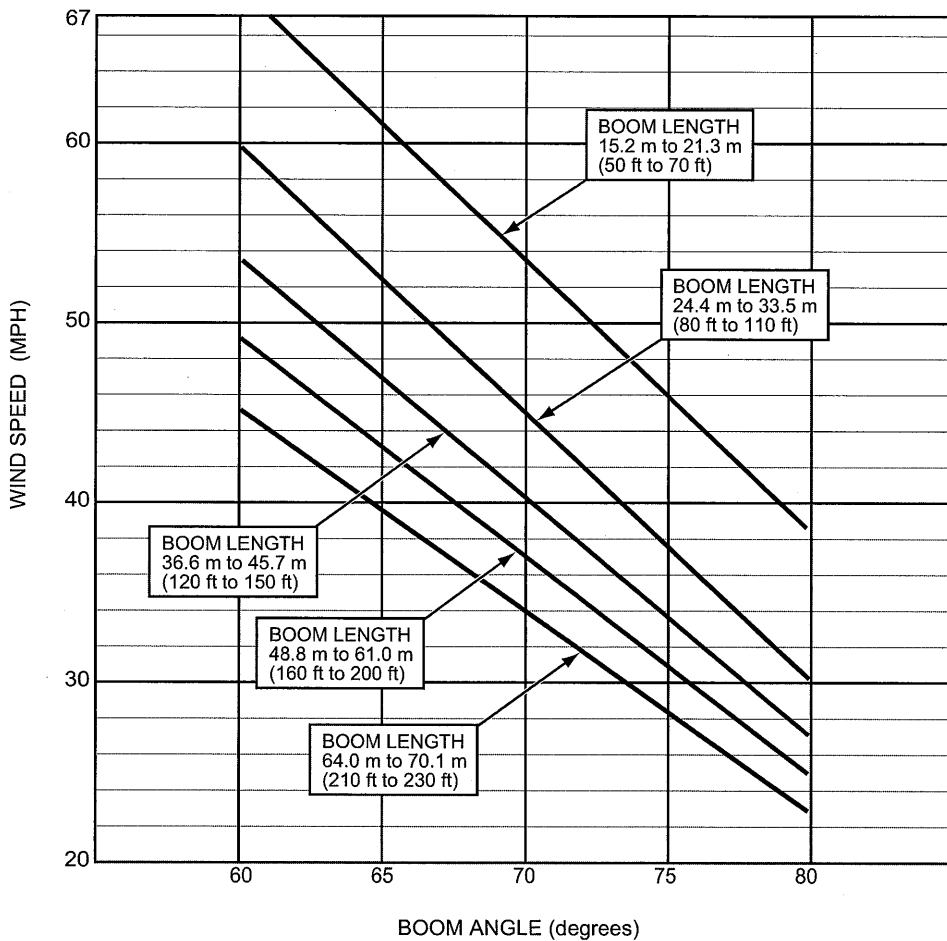

WITH 9.1 m (30 ft) JIB

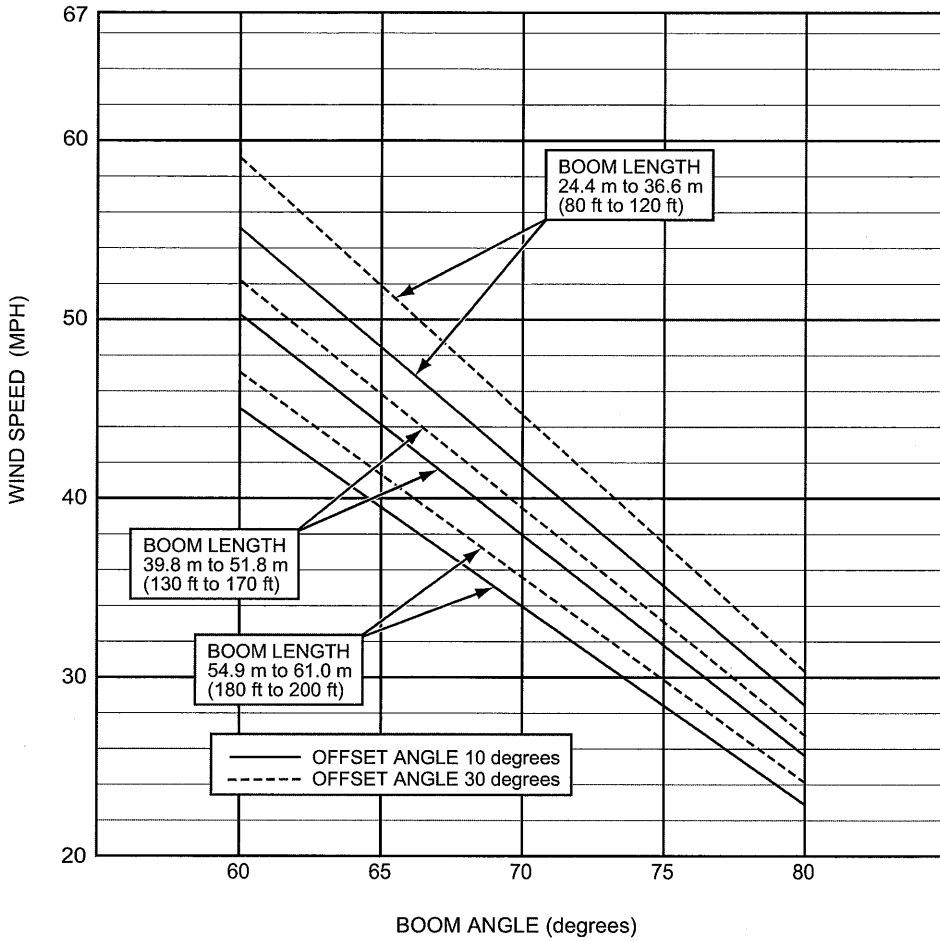

WITH 12.2 m (40 ft) JIB and 15.2 m (50 ft) JIB

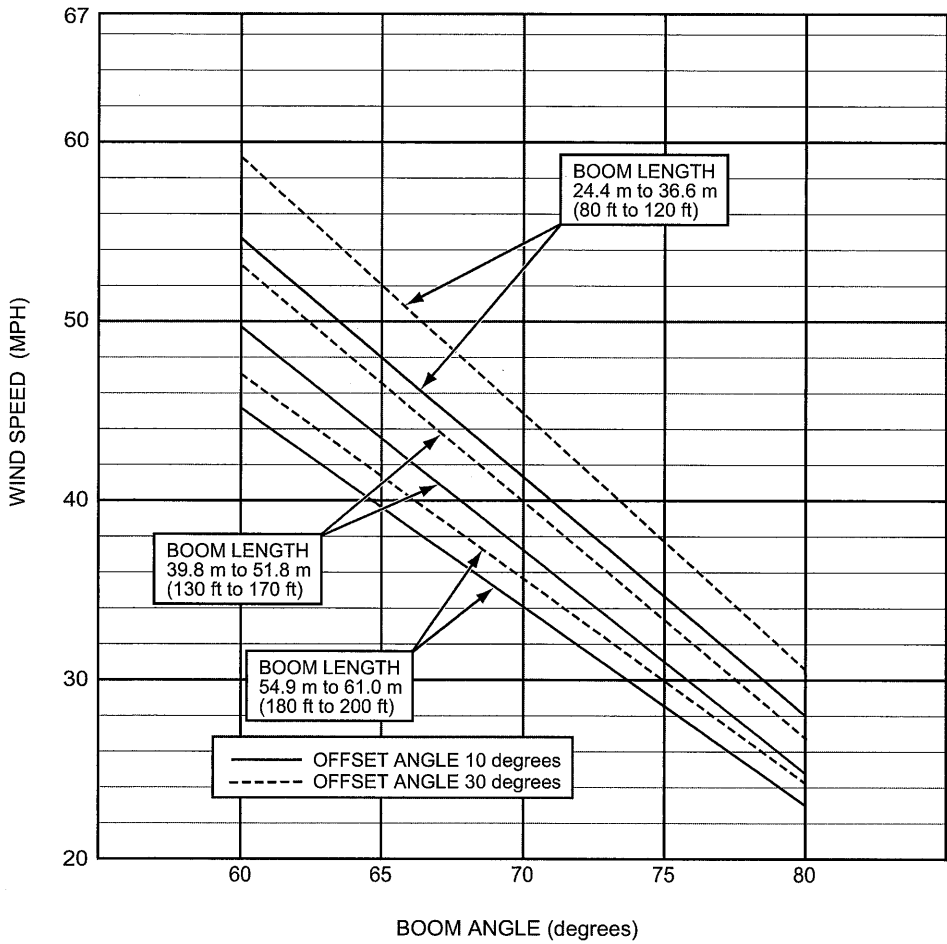

WITH 18.3 m (60 ft) JIB and 21.3 m (70 ft) JIB

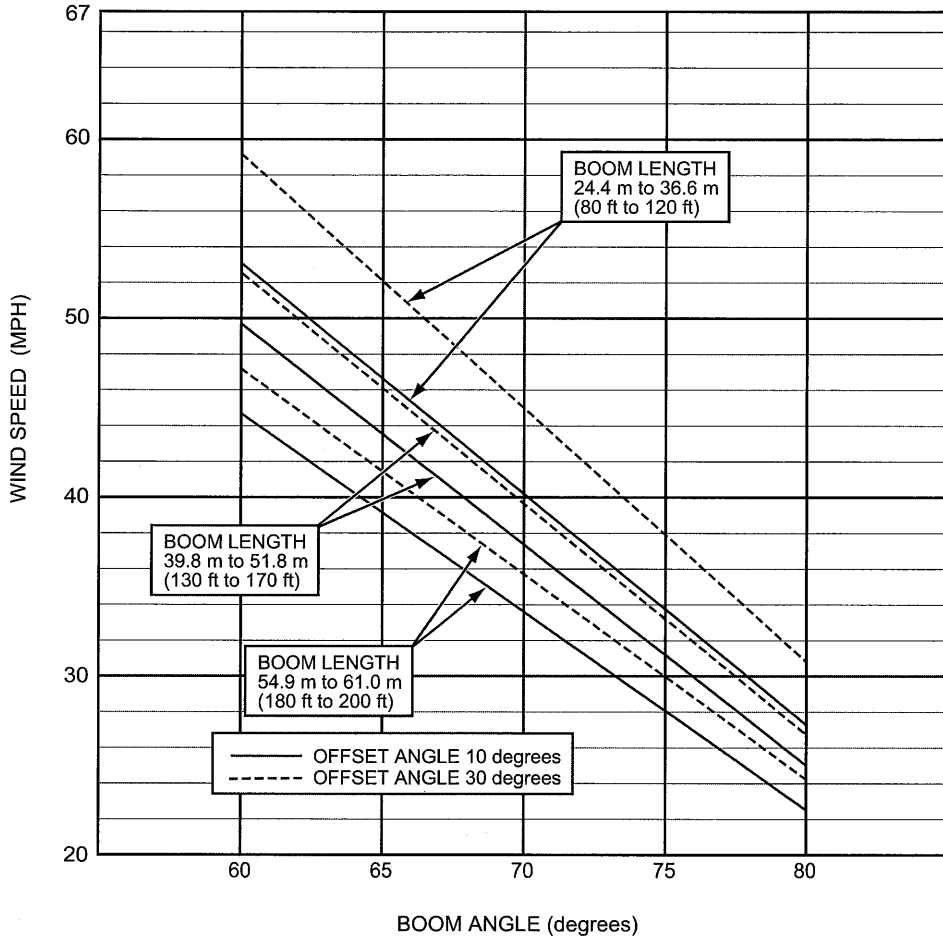

2.9.2 CAUTION AGAINST ELECTRIC SHOCK

If the machine or load comes close to the power lines, danger of electric shock becomes possible.
Follow local rules and regulations.

DANGER

There is a possibility of serious accident such as injuries or loss of life of personnel when the crane boom or lifting load comes close to or contact with power line.

Furthermore, an accident can be extended to :

- Power supply cut to homes and factories.
- Power supply cut to hospital affecting life of patients.
- Affect to the traffics such as power cut to the traffic signal etc.

These may cause secondary accident.

Whenever crane work is to be done near the power line, strictly observe the following precautions and to prevent such accident.

Failure to observe these precautions may result in a serious injuries or loss of life.

DANGER

While the boom or lifting load is touching the power line, do not get off the machine.

If person get off the machine while holding a part of machine, person will be electrocuted.

Never hold any part of machine.

Failure to observe this precaution may result in a serious injuries or loss of life.

1. Hold a meeting with the power company to understand the dangerous location in advance.
2. Place a signal person and keep safe distance between the machine, lifting load and the power line.

Refer to the article "SAFETY".

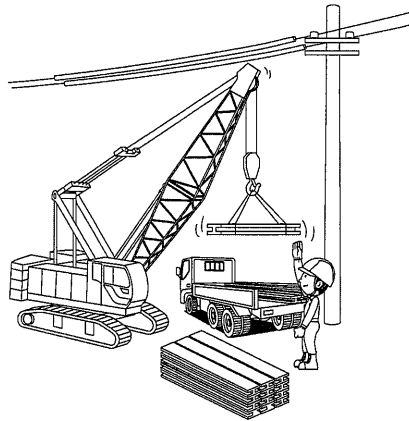

3. If coming close to the power line is unavoidable, advise the power company and obtain the protective insulated tube to prevent electric shock.

ACTION IN CASE ACCIDENT OCCURS

Should an accident occur, take the following actions immediately to minimize damage.

- (1) Advise the nearest power company office.
- (2) Operator without getting panic, should remove the boom or lifting load from the power line. If removing is not possible, it is safer to stay on the machine. Operator would be electrocuted by getting off the machine holding a part of machine.
- (3) Should someone be injured, immediately take emergency treatment such as artificial respiration or heart massage.
- (4) If the power line is cut, do not allow any person to come close to the loose power lines.
- (5) Inspect the machine (specially on load safety device) for proper function before reuse.

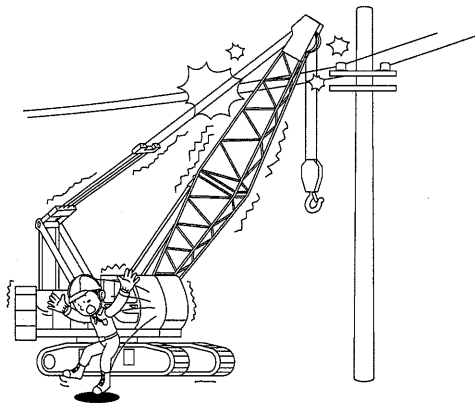

2.9.3 CAUTION AGAINST RADIO WAVE INTERFERENCE

If the machine is operated near the radio or TV transmitting station, boom, wire rope or hook may be charged with electricity.

If charged it may lead to the danger such as trouble in slinging to the hook or damage to the safety device.

CAUTION

When working near the transmitting station's antenna, the boom or wire rope may function as an extra large antenna and may be charged with electricity and the high voltage may be induced at the end of the hook and may be heated.

Touching the hook may cause burns due to the electric shock or heat.

The computer installed on the machine may malfunction.

Take extra care in operating the machine.

Failure to observe these precautions may result in an accident a serious injuries or loss of life.

PREVENTIVE MEASURE

1. Use insulating gloves.
2. Connect the grounding wire to the hook.
3. Wrap around the hook with insulating materials.
4. Use nylon rope (belt type) for sling.

Consult KOBELCO service shop if electrical component installed on the machine is failed.

2.9.4 CAUTION AGAINST LIGHTNING

When the machine is hit with lightning, fatal accident is likely to the operator or surrounding personnel.

Various portion of machine may also be damaged.

1. Take the following actions immediately when the thunder cloud appears and lightning is expected.
 - (1) Stop the work and lower the lifting load on the ground.
If the boom can be lowered, lower it on the ground.
 - (2) Engage the brake/lock (hoist, swing) and stop the engine and turn the key to OFF.
 - (3) Get away from the machine and surrounding area.

2. If the machine is hit with lightning, check the following points.
 - (1) Is there any burning out or damage?
 - (2) Do all the electrical devices or load safety devices work properly?
 - (3) Does each function work properly?

2.9.5 COUNTERMEASURE AGAINST EARTHQUAKE

Earthquake is unpredictable for its time or size.
It is essential to prepare always against earthquake.

1. Preparation against earthquake.
Lower the boom on the ground after completion of daily work.
2. Action when earthquake occurs.
Stop work immediately and stop the machine and turn the engine key to OFF position.
Evacuate to the safety place taking care about fallen materials.
3. Inspect the following points when re-starting the machine.

- (1) Ground condition of the machine placed.
- (2) Damage of the machine.
- (3) Function of the machine.

Do not operate the machine until the damage is repaired.

3. LOAD SAFETY DEVICE

3.1	ARRANGEMENT OF EQUIPMENTS.....	3-3
3.2	TYPES AND FUNCTIONS OF EQUIPMENT	3-7
3.3	CONNECTING PROCEDURE OF WIRING.....	3-14
3.3.1	CRANE ATTACHMENT	3-14
3.4	FUNCTION OF MONITOR.....	3-21
3.5	OPERATING PROCEDURE OF MONITOR.....	3-22
3.5.1	SETTING OF CRANE CONFIGURATION.....	3-27
3.5.2	SELECTION OF MAIN LIFTING / AUXILIARY LIFTING.....	3-35
3.5.3	SETTING OF WORK AREA LIMIT VALUE.....	3-36
3.6	SWING LIMITATION DEVICE (OPTION).....	3-41
3.7	FUNCTION OF GROUND INCLINE INDICATOR (OPTION).....	3-51
3.8	LOAD HISTORY (DATA LOGGER).....	3-52
3.9	ALARMING AND AUTO-STOP	3-53
3.9.1	CONTENT OF ALARM AND AUTO-STOP	3-53
3.9.2	CONTENT OF AUTO-STOP	3-54
3.9.3	RELEASING AUTO-STOP	3-56
3.10	INSPECTION.....	3-62
3.10.1	INSPECTION PROCEDURE WHEN RAISING THE BOOM AFTER THE ATTACHMENT ASSEMBLY WORK IS COMPLETED	3-62
3.10.2	INSPECTION AFTER ERECTING ATTACHMENT	3-64
3.11	CAUTIONS IN HANDLING LOAD SAFETY DEVICE.....	3-66
3.12	ERROR CODE AND MESSAGE	3-67
3.13	MESSAGE TABLE	3-78
3.14	CHECKING PROCEDURE OF LOAD SAFETY DEVICE	3-84

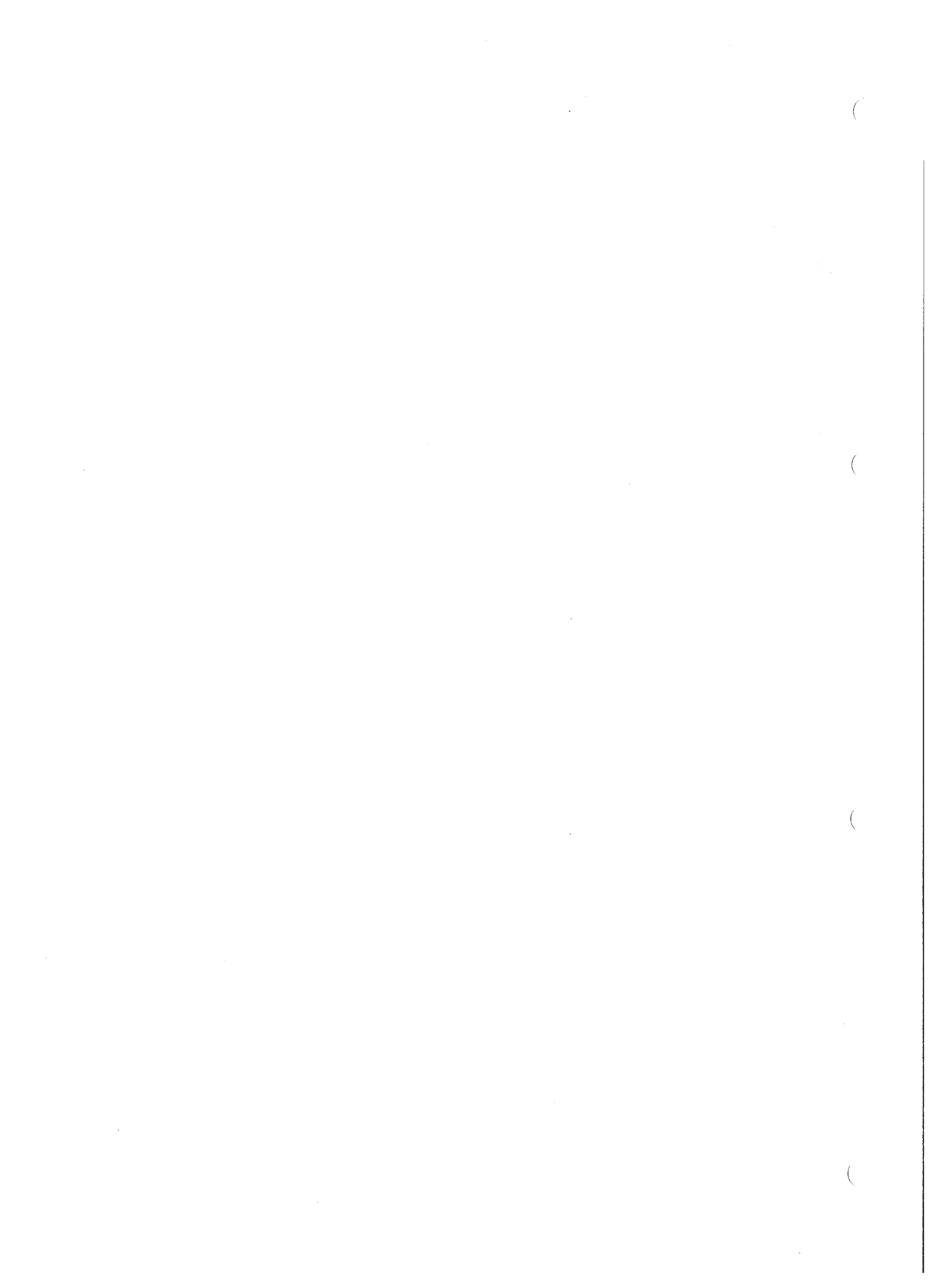

3. LOAD SAFETY DEVICE

This machine is provided with various load safety devices to operate the machine safely.

The machine conditions are detected with various devices and are controlled with the controller and are displayed with the monitor to prevent damage to the crane or luffing tower due to overload, overhoist or to prevent overturning of the crane.

Ensure to use this device to operate the crane safely and inspect and maintain the device periodically.

If the device becomes inoperable, repair immediately before restarting the work.

Safety device of this machine

- Load safety device
- Hook overhoist preventive device
(Crane, aux. sheave, jib)
- Boom overhoist preventive device

 **CAUTION**

- **The load safety device is important to operate the crane safely.**
Make sure that the device works properly and use this device surely during work.
 - **If the load safety device is used improperly, released in unsafe way, or maintenance and repair being neglected, machine may be damaged or may serious accident such as overturning.**
 - **The load safety device is an important device to work in safe manner.**
Even if the load safety device functions correctly, wind influence, ground collapsing or incorrect adjustment of the device may cause machine damage or overturning.
Exercise caution to reduce electric shock or radio wave interference.
If there is a possibility of strong wind, earthquake or lightening, stop work immediately.
 - **Never operate the crane by releasing the load safety device auto stop switch or release switch master key.**
Never use the load safety auto stop release switch other than on inspection and maintenance purpose.
The release master key must be kept in a place that the site foreman has determined to be the safest place.
 - **Never operate the crane with releasing the release switch and release switch master key of the hook overhoist and boom overhoist.**
Never use the release switch of the hook overhoist preventive device and the boom overhoist preventive device other than at the safety device failure, damage, emergency evacuation or for inspection, and maintenance.
 - **Never adjust the length of hook overhoist weight wire or boom limit striker and angle sensor of angle of the load safety device since they are pre-adjusted.**
The release master key must be kept following the instruction of work control person.
-

3.1 ARRANGEMENT OF EQUIPMENTS

The part name and the item number in the figures of arrangement of equipment correspond to the description in the section 3.2.

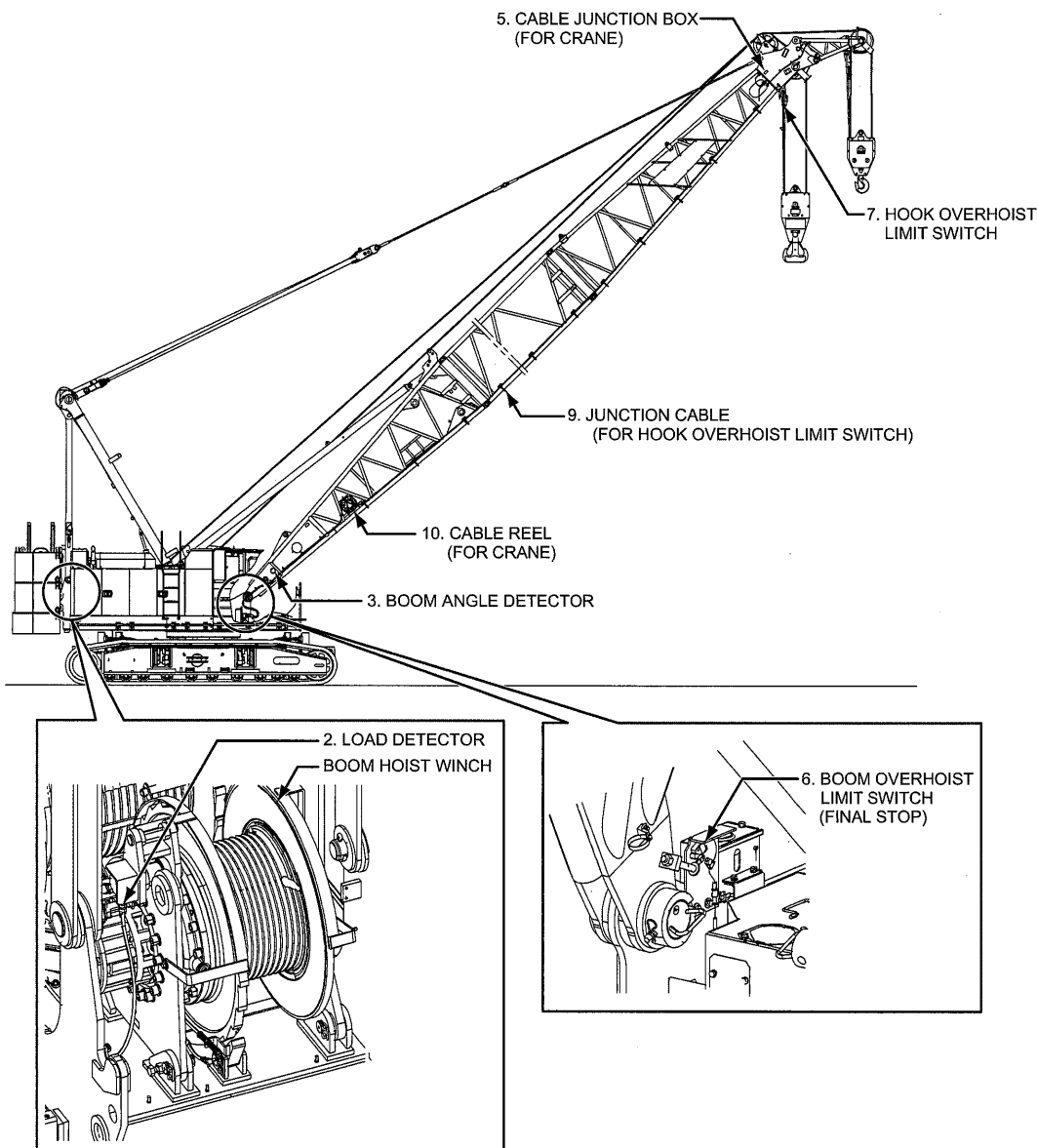

3

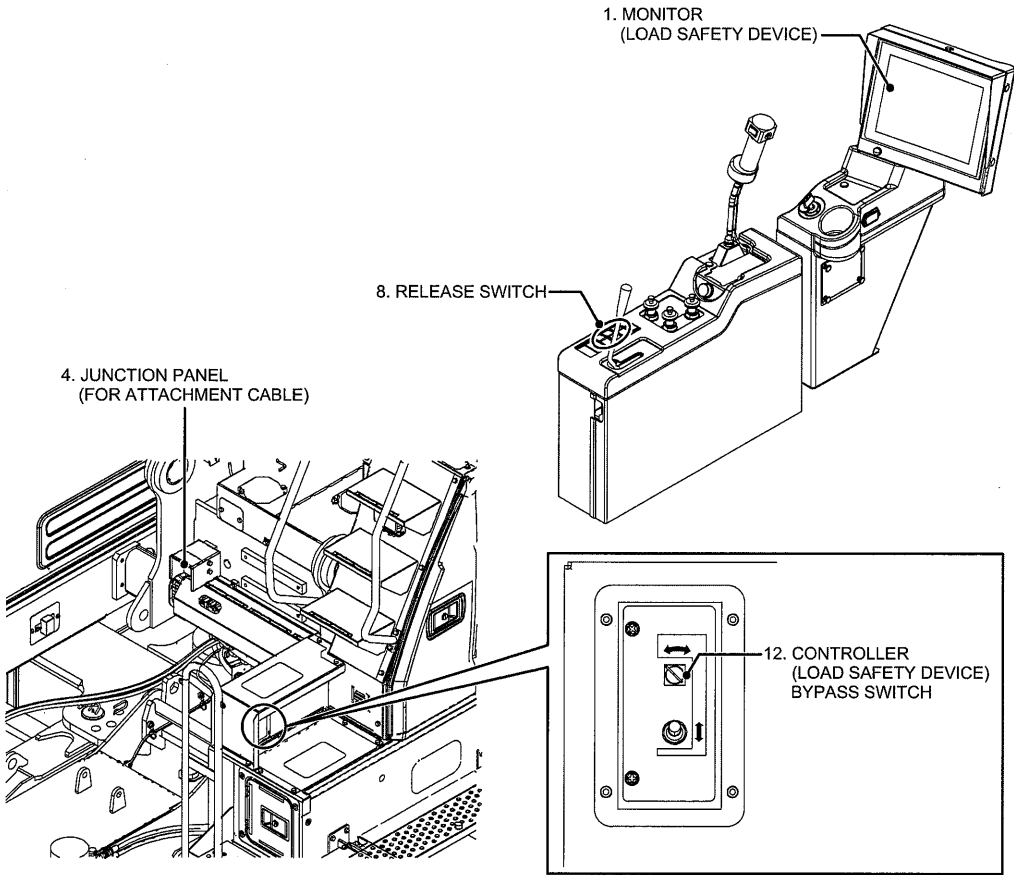

FIXED JIB

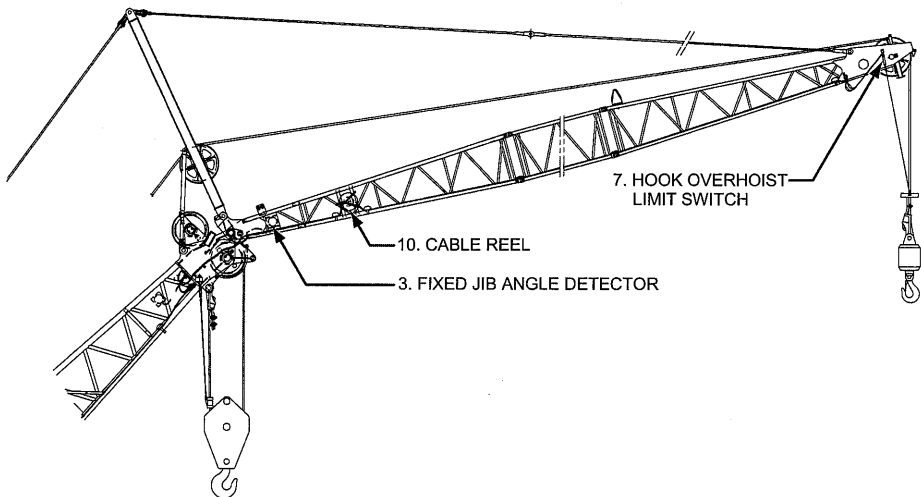

3

AUXILIARY SHEAVE

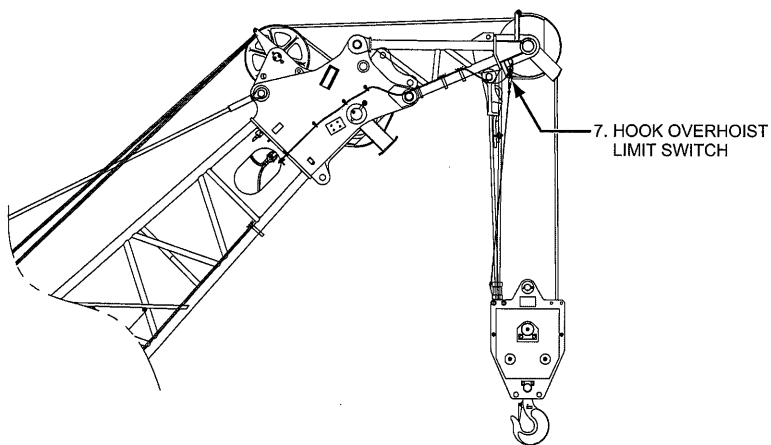

DETAIL OF OPERATOR CAB LEFT SIDE STAND
PANEL

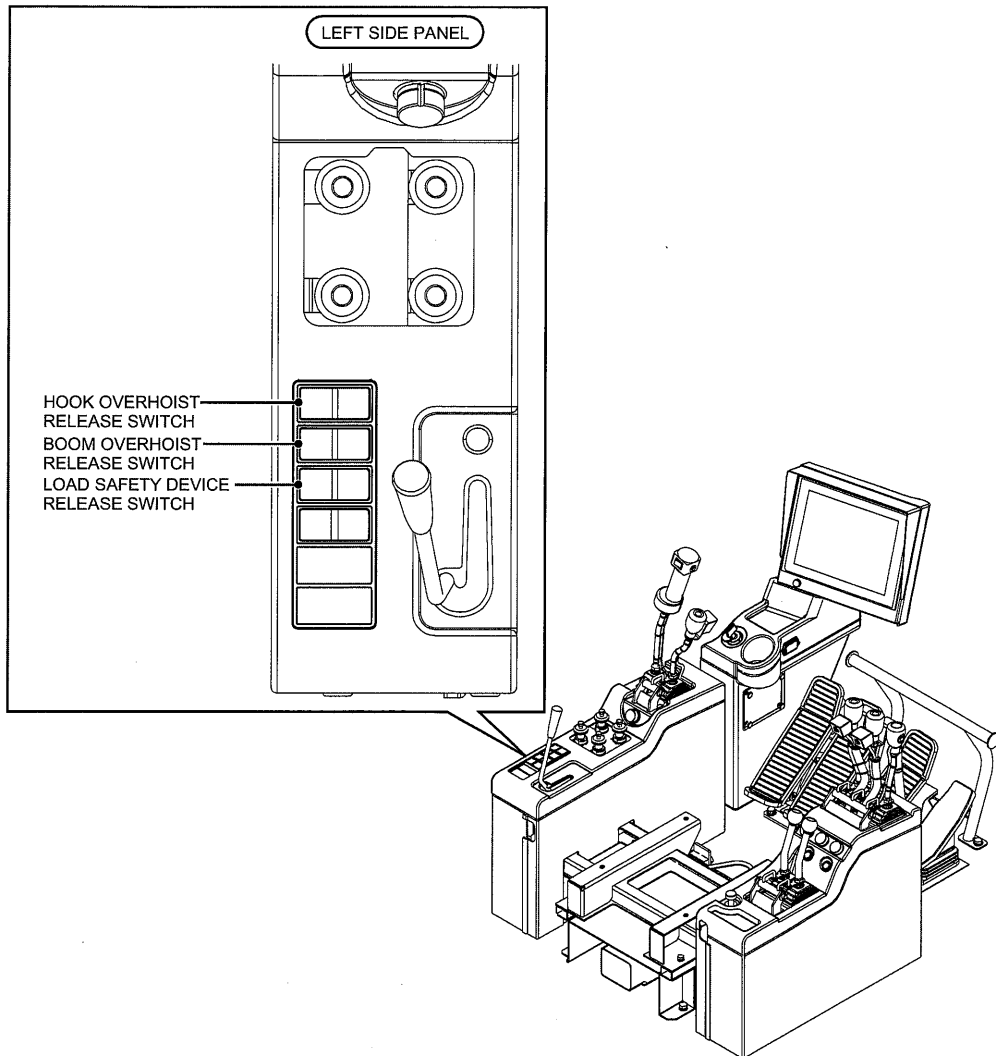

DETAIL OF BOOM OVERHOIST LIMIT SWITCH

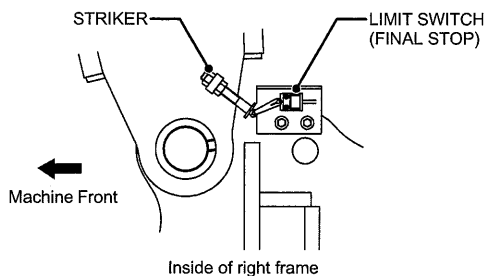

3.2 TYPES AND FUNCTIONS OF EQUIPMENT

1. MONITOR (LOAD SAFETY DEVICE)

This monitor indicates the machine condition, and issues the signal for the alarms and stop as required.

Note

All values in the monitor displays are for reference only.

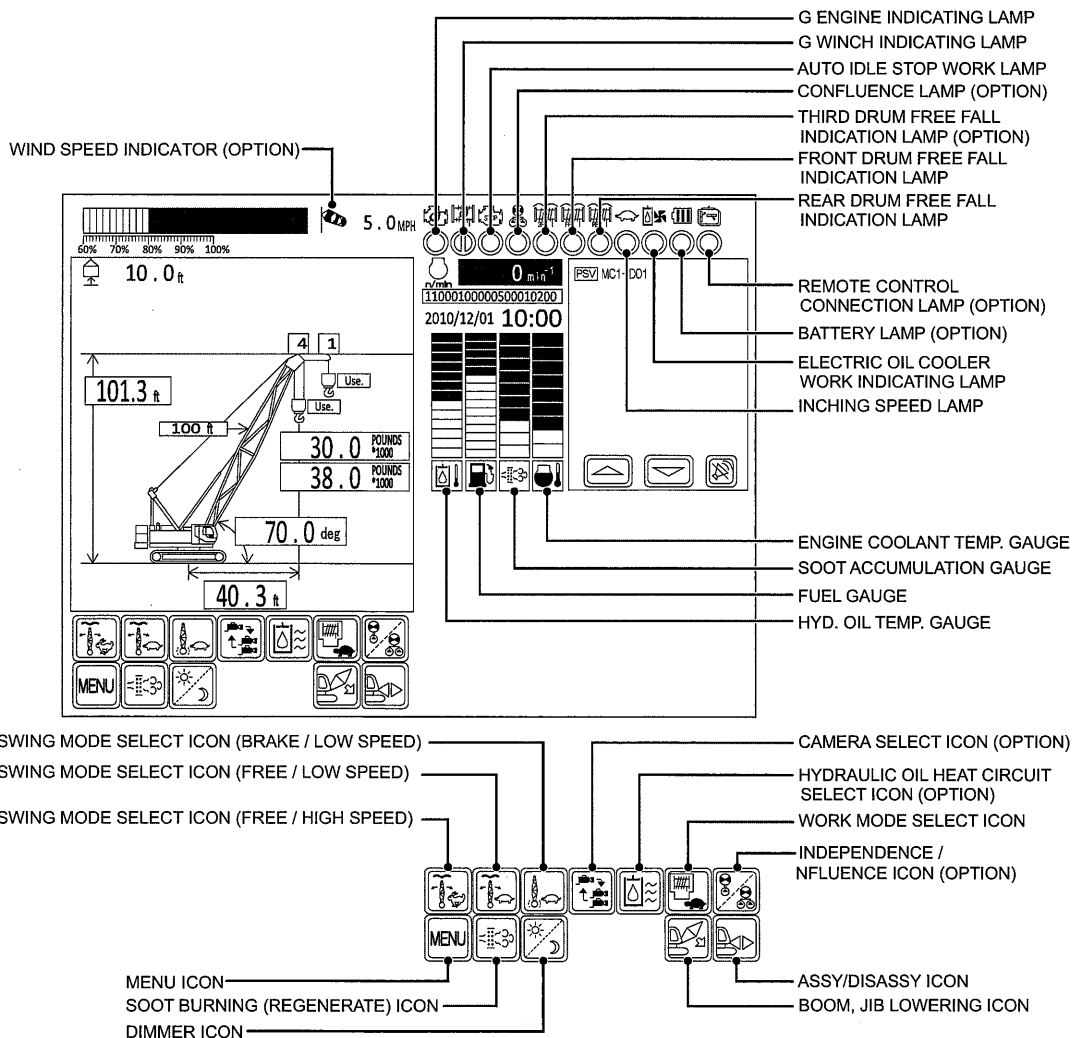

2. LOAD DETECTOR

This pin detects load.

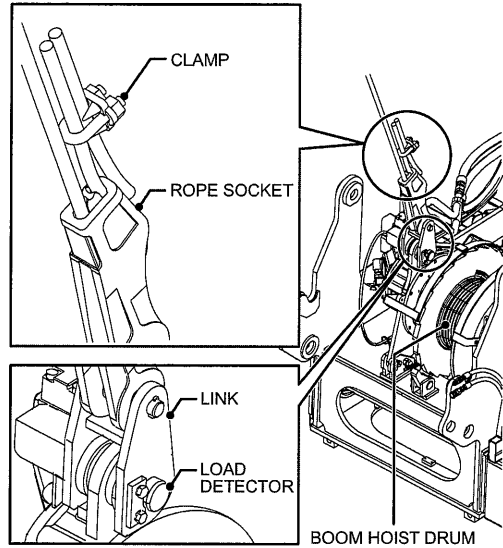

3. ANGLE DETECTOR

This device detects the angle of boom and jib.

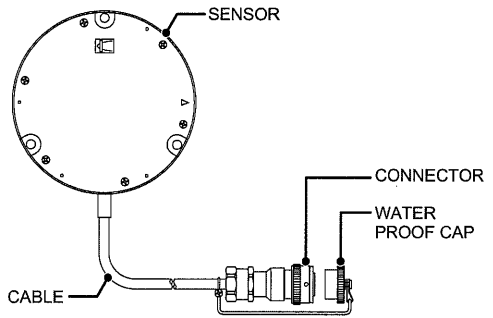

4. ATTACHMENT JUNCTION PANEL

This is the connecting area for the attachment detector cable to operator's cab cable.

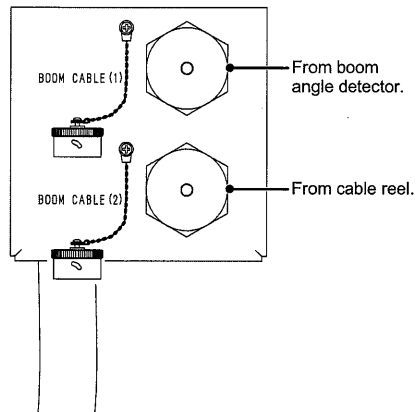

5. CABLE JUNCTION BOX

This is the junction box for detector and limit switch.

- FOR CRANE BOOM TOP

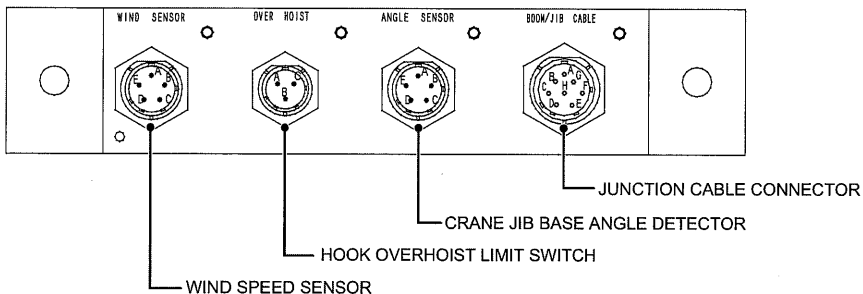

3

6. BOOM OVERHOIST LIMIT SWITCH (FINAL STOP)

This prevents the boom from overhoisting.

This is the final stop limit switch.

When crane is stopped due to this limit switch actuated, auto-stop can not be released.

If used as the tower crane, auto-stop does not function even when the boom overhoist limit switch is actuated.

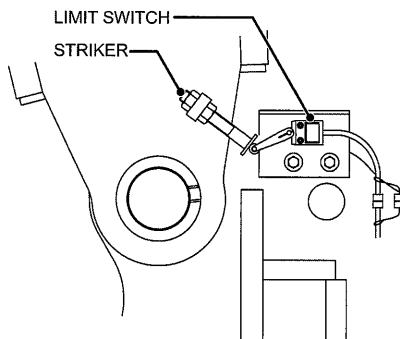
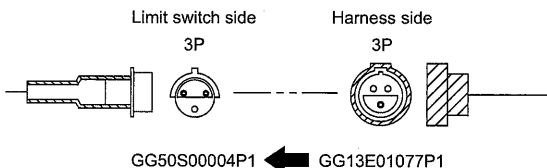

7. HOOK OVERHOIST LIMIT SWITCH

These switch prevent the hooks from overhoisting.

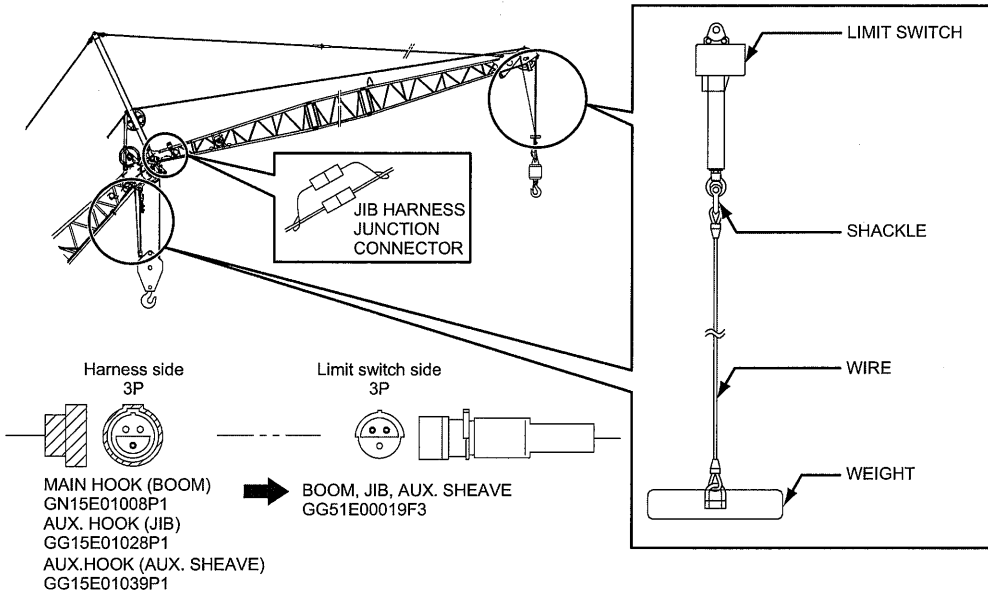

8. RELEASE SWITCH

These switches release auto-stop function.

Refer to the article "3.9.3 RELEASING AUTO-STOP".

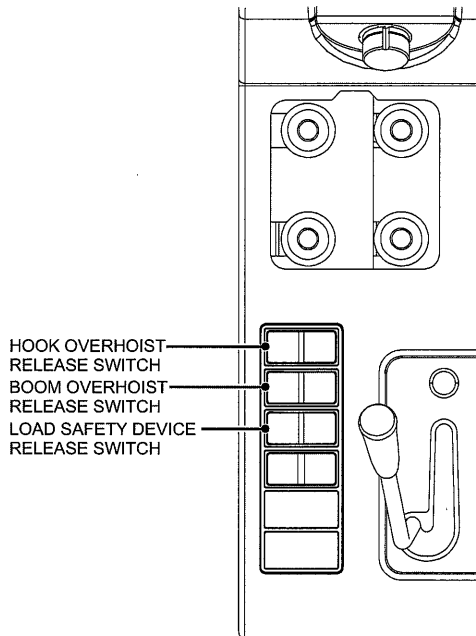

9. JUNCTION CABLE
(CRANE : FOR HOOK OVERHOIST)

Connect from each cable junction box to the attachment junction panel.

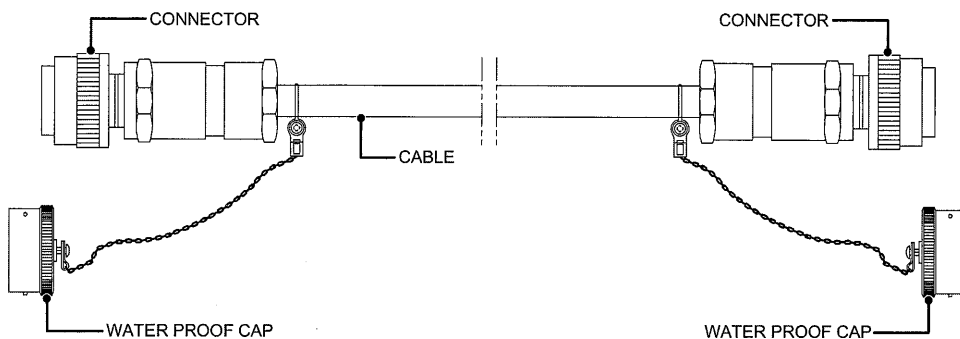

3

10. CABLE REEL

This is to store electrical cables.

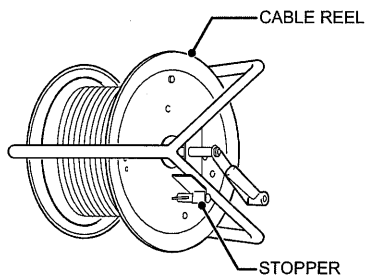

11. OVERLOAD ALARM LAMP (LOAD SAFETY DEVICE OUTSIDE INDICATION LAMP) (OPTION)

The overload alarm lamp (load safety device outside indication lamp) is used to issue alarms with the red lamp to outside of machine when the attachment is to be self erected, disassembled, stowed or at boom overhoisted in case of assembly/disassembly configuration.

Content of 3 color lamp indication

- Load ratio lower than 90% : Green lamp light up
- Load ration between 90 to 100% : Yellow lamp light up
- Load ration higher than 100% : Red lamp light up

Indicated status	Red	Yellow	Green	Buzzer
Load ratio is less than 90%			○	
Load ratio ranges from 90 to 100%		○		○
Load ratio is 100% or more	○			○
Hook overhoist			○	
Boom overhoist (crane)			○	
Tower overhoist			○	
Tower jib overhoist			○	
Tower jib overlowering	○			○
Assembly configuration (at assembly and disassembly)	○			
While the overload release switch is actuated	○			○

CAUTION

Do not operate crane while red lamp is ON except during assy/disassy with caution.
Do not modify the overload alarm lamp circuit.

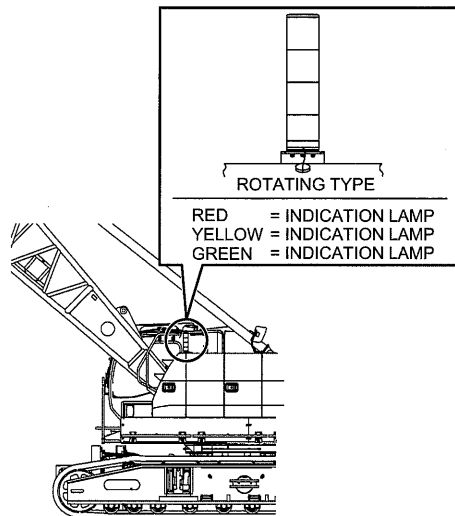

12. CONTROLLER (LOAD SAFETY DEVICE) BYPASS SWITCH

This switch is used to release the auto-stop function when the controller (load safety device) becomes inoperable.

⚠ DANGER

When the controller is functioning properly, bypass function will not work even when the bypass switch is released.

During the crane work with using the bypass switch, indication, warning or auto-stop does not work.

(Auto-stop function by overhoist preventive device works.)

Repair or replace the controller immediately.

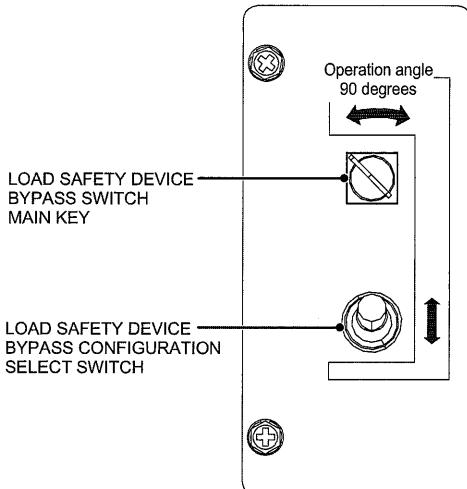

3

- LOAD SAFETY DEVICE BYPASS SWITCH MAIN KEY

In case of load safety device failure, the following configuration select switch becomes effective by turning the main key to ON.

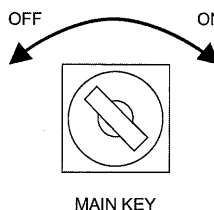

- LOAD SAFETY DEVICE BYPASS CONFIGURATION SELECT SWITCH

While the main key is turned ON, selecting the configuration can release each auto-stop function.

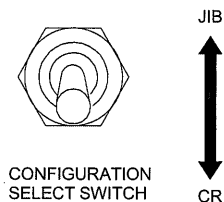

JIB : Select when the luffing configuration is to be selected. (Not used.)

CR : Select when the crane configuration is to be selected.

On this model, use the machine with this switch turning to "CR" position.

3.3 CONNECTING PROCEDURE OF WIRING

3.3.1 CRANE ATTACHMENT

1. Diagram of system

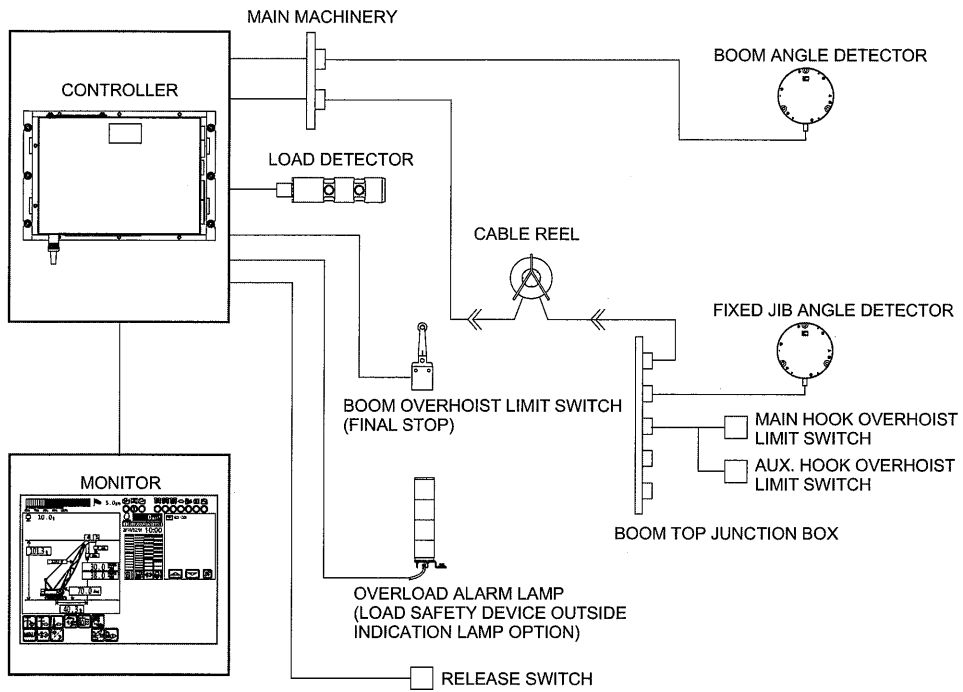

2. Connecting procedure

CAUTION

The cable should be handled with care in order to avoid damage.

Do not pull or fasten.

When assembling the basic machine and attachment, make the connections as follows.

When disassembling, disconnect the connectors in the reverse order.

Before connecting the connectors, make sure that no foreign objects, water is in the connectors section of the connector.

- Insert the connector tightly and tighten firmly.
- Connect the removed caps together.
- After disconnecting, install the cap securely.

CAUTION

Overload preventive device may not work correctly if water is in the connectors.

CAUTION

Ensure to turn the key switch OFF to avoid any adverse affect to the electric devices when the connectors are in the process of connecting or disconnecting.

CAUTION

Ensure to match the key position of the plug and receptacle when connecting the connector to avoid damage to the connector.

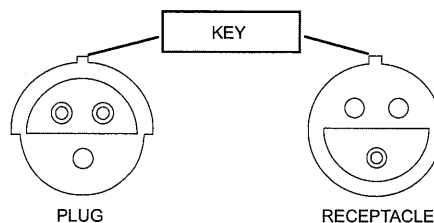
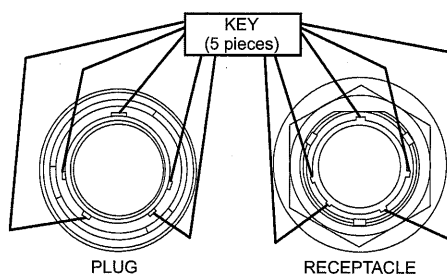

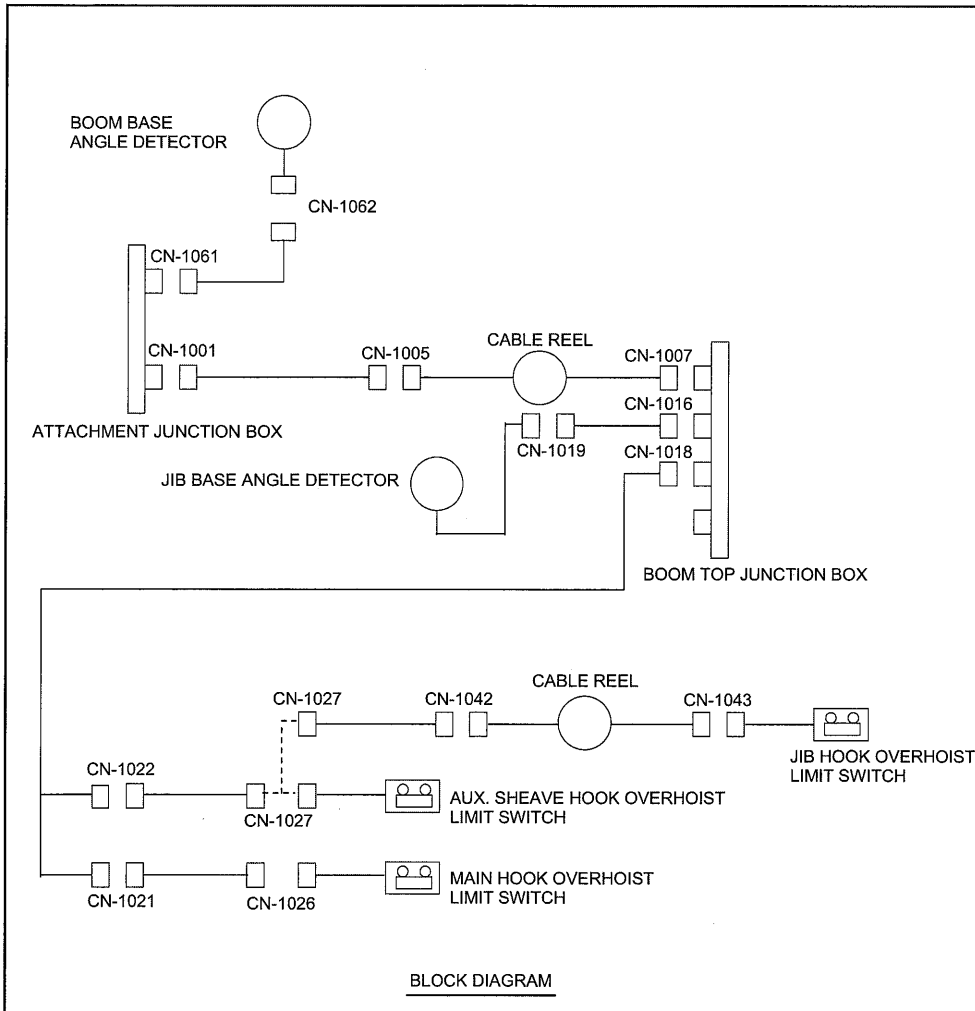
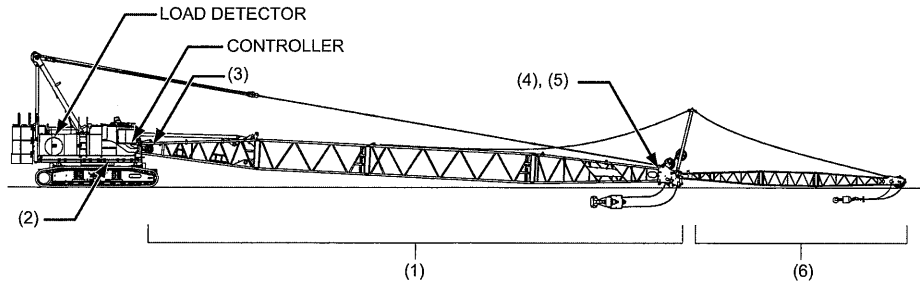

- (1) Secure the junction cable or limit switch cable to the boom or the jib with hangers.

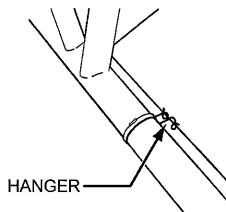

- (2) Connection of attachment harness and main machine harness

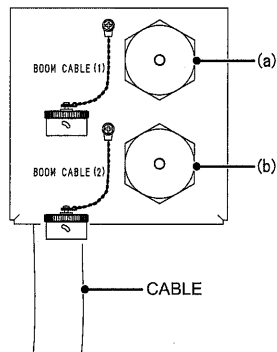
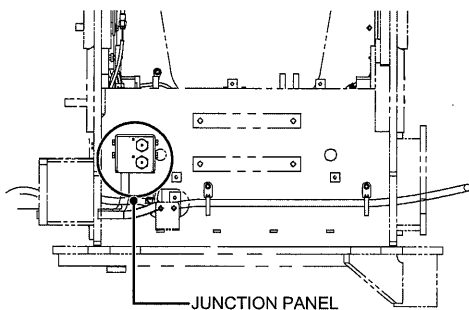

Detail of junction panel

- (a) ··· Connect the junction cable 1 (from boom angle detector).
- (b) ··· Connect the junction cable 2 (from cable reel).

- (3) Connection of the cable reel area

At Crane work

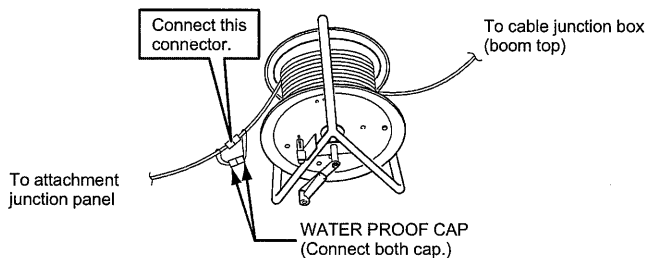

WARNING

Do not operate crane while the water proof caps are connected to the cable.
The auto-stop and alarming will not be issued when hook overhoist occurs.
Failure to observe this precaution may result in a serious accident.

At transportation

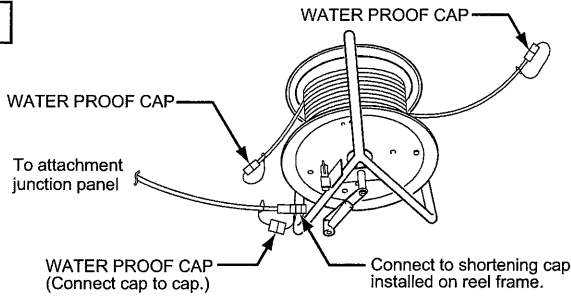

(4) Connection of boom top area

The cable support hook is provided on the boom top area.
Hang the cables on these hooks.
Otherwise unsafe force would be applied on the hook limit connector.
Ensure to hang thimble on these hook.

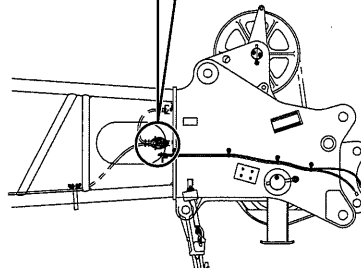
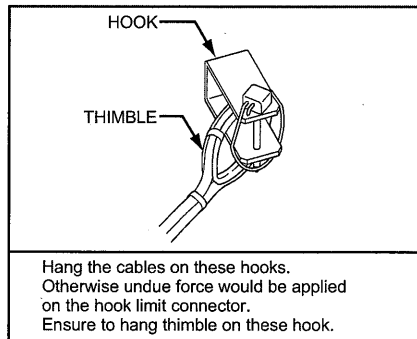

(5) Connection of hook overhoist limit switch area
(Crane work with aux. sheave)

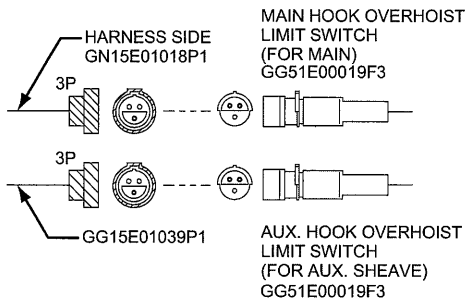

3

In case without the aux. sheave

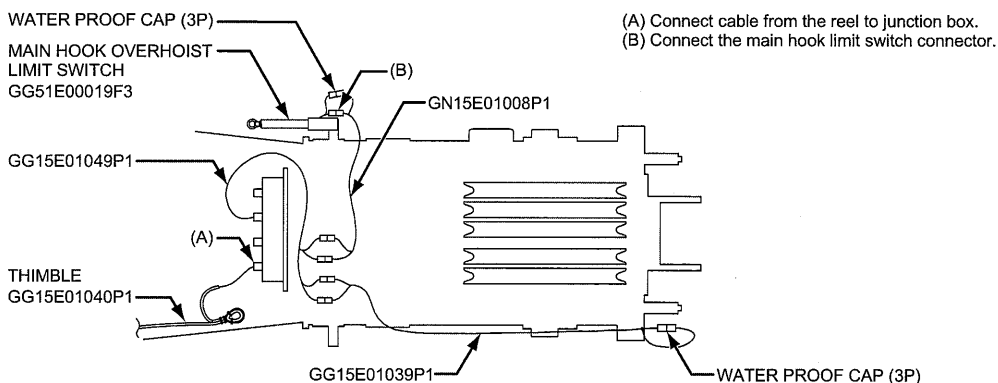

In case with the aux. sheave

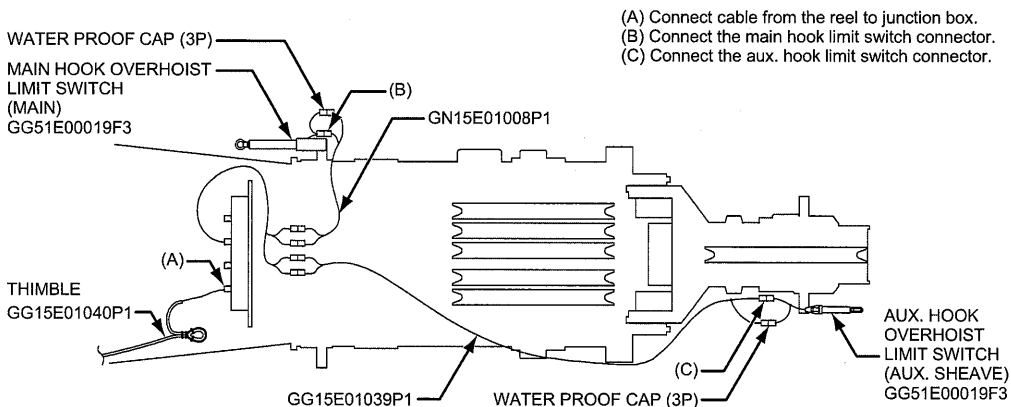

(6) Connection of jib area (in case with fixed jib)

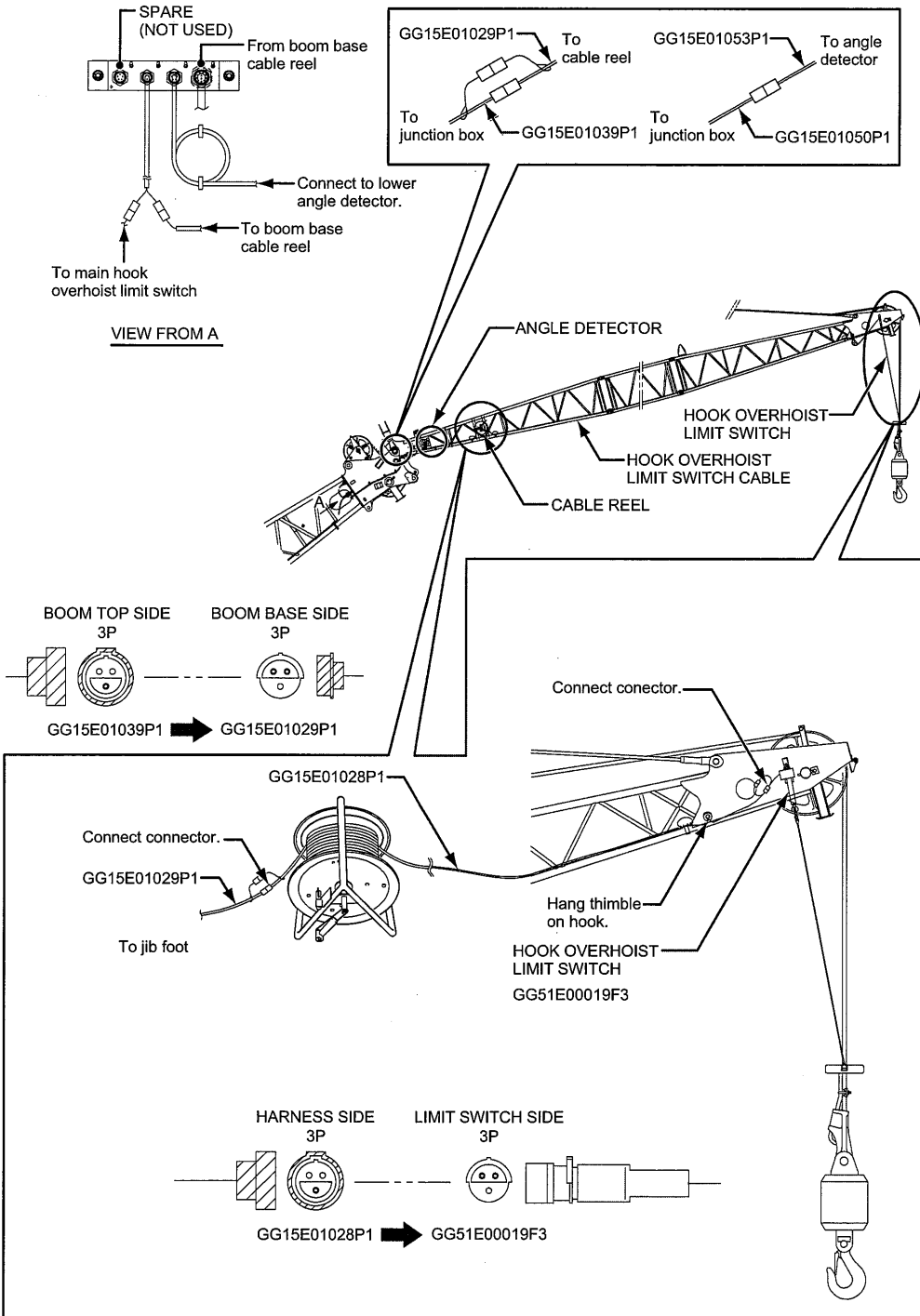

3.4 FUNCTION OF MONITOR

Change the screen protector if it is dirty or damaged.

CAUTION

Do not press the touch panel screen with sharp object such as tool or handle with excessive force to avoid monitor failure.

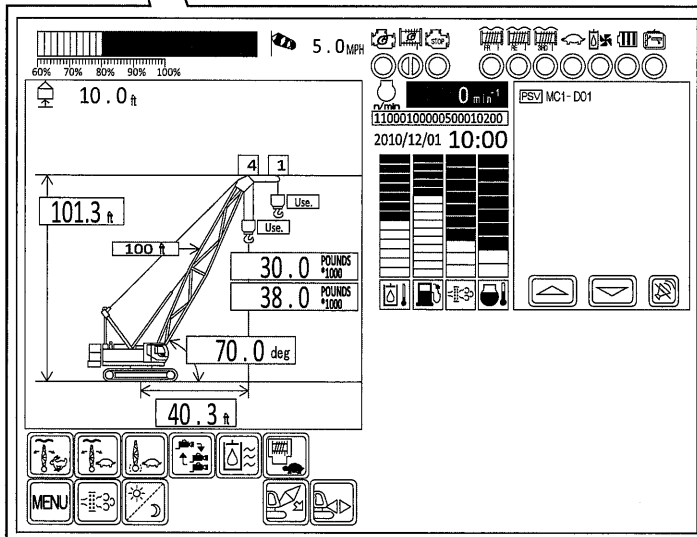
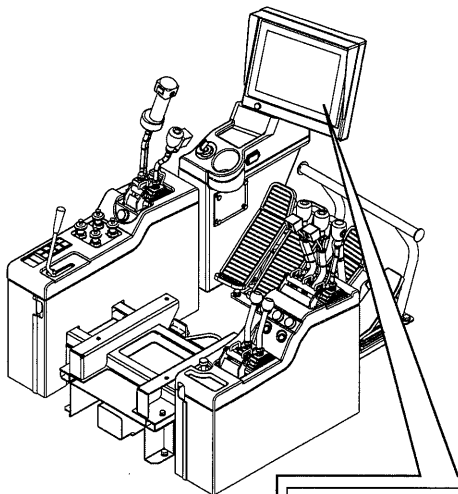

CAUTION

All values in the figure are for reference only.

3.5 OPERATING PROCEDURE OF MONITOR

Referring to the setting items (following), perform necessary setting.

Setting item			
	Daily operation	Operation after changing attachment	Operation at initial erection
(1) Setting of crane configuration	×	○	○
(2) Selection of main/aux. lifting	□	○	○
(3) Setting of working area limit value	□	□	□

○ : Necessary × : Unnecessary □ : If necessary

The set values are memorized and retained in the controller even by stopping the engine or turning the power off.

1. Turning power on

When the key switch is turned to the ON position, power will be supplied to the monitor.

If power is not supplied to the monitor, check the fuse.

When power is supplied to the monitor, the following screen is displayed on the monitor as follows.

3

CAUTION

It may take several seconds to start the monitor and display this.

Mean while, do not operate the crane.

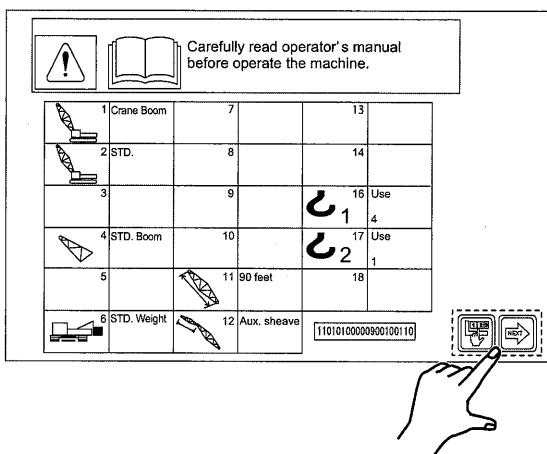

Read the operator's manual carefully before operating the machine.

The crane configuration is indicated on the screen.

Check to see that this configuration matches with the actual crane configuration.

If so, press icon.

If different, re-setting required.

Press icon and start setting.

Referring to "3.5.1 SETTING OF CRANE CONFIGURATION".

Note

An optional items or a custom specification are indicated in the blank on the monitor.

2. Screen example

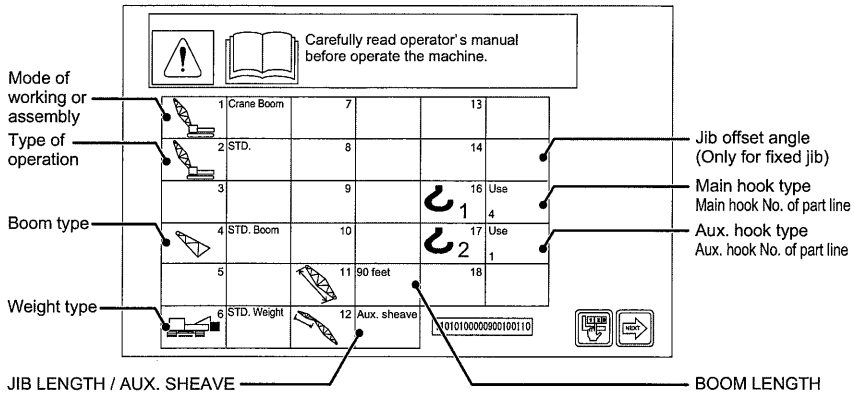

Then setting condition of work area limit is displayed.

After checking the content, press icon.

By pressing icon, setting can be changed.

Refer to "3.5.3 SETTING OF WORK AREA LIMIT VALUE".

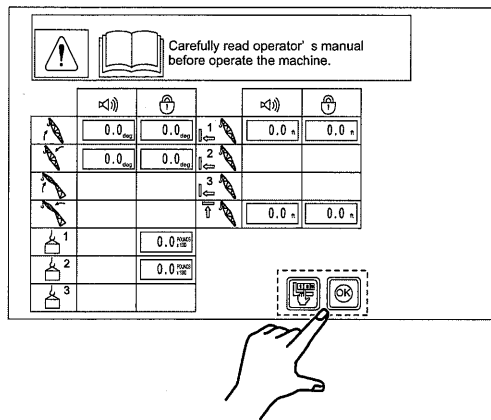

Main screen is displayed and the crane is ready to operate.

As for the detail of message display area, refer to "3.13 MESSAGE TABLE".

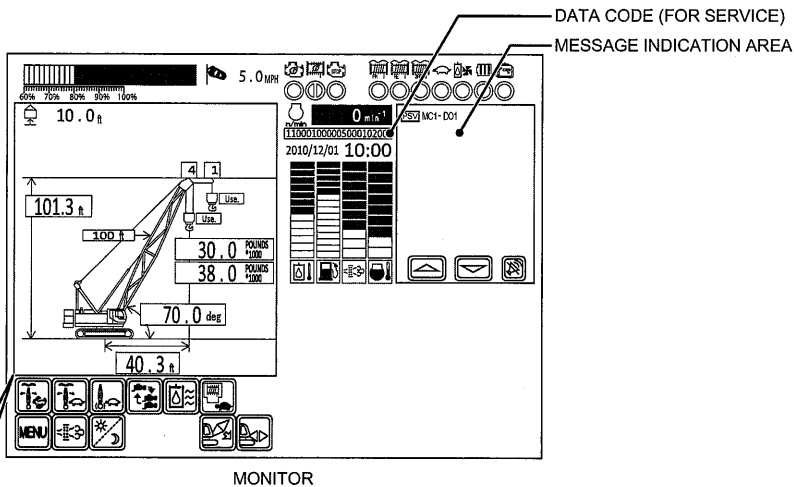

3

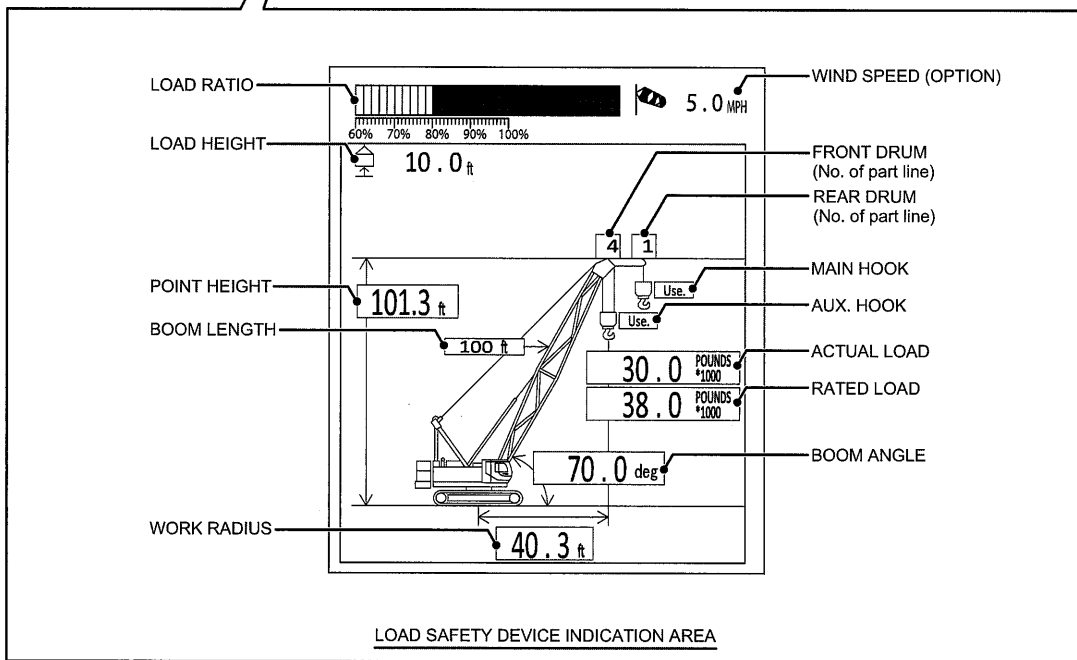





3. How to read load safety device indication

• Each data display (Example of indication)

Name	Display ex.	Content
(1) Boom angle indication	70.0 deg	Indicate boom angle by 0.1 degrees unit.
(2) Jib offset angle indication	10 deg	For fixed jib, indicate selected angle.
(3) Point height indication	101.3 ft	Indicate boom or jib point height by 0.1 ft unit
(4) Work radius indication	40.3 ft	Indicate work radius by 0.1 ft unit.
(5) Actual load	30.0 ^{POUNDS} / _{*1000}	Indicate actual load by 0.1 klbs unit.
(6) Rated load	38.0 ^{POUNDS} / _{*1000}	Indicate rated load by 0.1 klbs unit.
(7) Load height indication	30.0 ft	Indicate hook position from zero rest position by 0.1 ft unit.
(8) Boom length	100 feet	Indicate selected boom length.
(9) Jib length	40 feet	Indicate selected jib length. (Only for fixed jib)
(10) Front drum No. of part line	4	Indicate input No. of front hook rope No. part line.
(11) Rear drum No. of part line	1	Indicate input No. of rear hook rope part line.
(12) Main hook	Use	Indicate selected type of main hook.
(13) Aux. Hook	Use	Indicate selected type of aux. hook.
(14) Wind speed indication (option)	5.0 MPH	Indicate wind speed by 0.1 MPH.

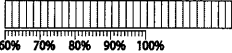
• Load ratio display (Example of indication)

Load ratio display area lamp lights up from left to right in order as load ratio increase.

Load ratio	Display
Less than 60 %	
76 %	
From 90 % to 100 %	
105 %	

3.5.1 SETTING OF CRANE CONFIGURATION

⚠ DANGER

Check to see if the crane configuration is properly set to prevent a serious accident.

Crane configuration setting is required on the type of attachment, boom length, with/without aux. sheave and type of hook.

1. Setting procedure

- (1) Press **MENU** icon while the main screen is indicated.
Menu screen is now displayed.

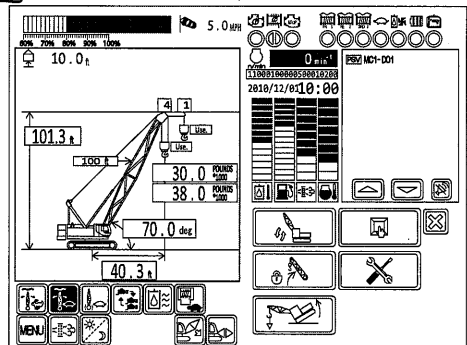
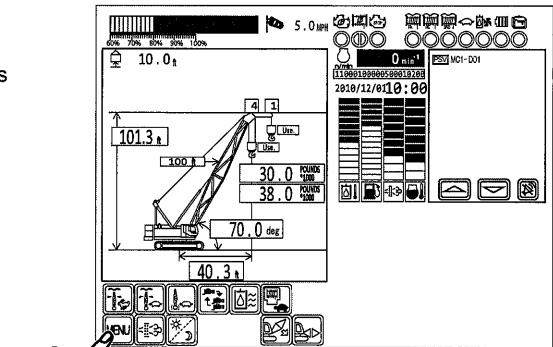



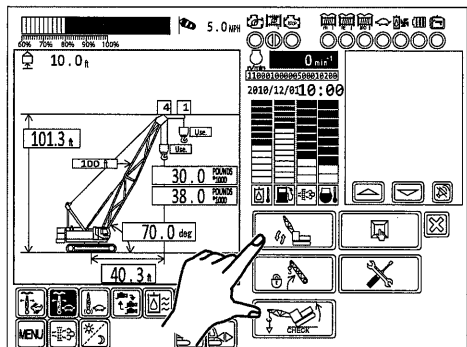





















































- (2) On the selected screen, match the **⚙** mark and press **SET** icon.
- (3) After this, select items according to the screen instruction.
Selection items are type of attachment, boom length, type of jib, jib offset angle, with/without aux. sheave, main hook/aux. hook and number of wire rope part line.



























DETAIL OF ATTACHMENT SYMBOL

The symbols used on this machine are indicated in gray.

1		16		31	
CRANE		BOOM ONLY (WITH HOOK)		CWT (VERTICAL 3)	
2		17		32	
LUFFING or TOWER		BOOM ONLY (WITHOUT HOOK)		CWT (VERTICAL 2)	
3		18		33	
HL CRANE		WITH AUX. SHEAVE (WITH HOOK)		CWT (VERTICAL 1)	
4		19		34	
HL LUFFING		WITH AUX. SHEAVE (WITHOUT HOOK)		CWT (VERTICAL 2) CRAWLER RET.	
5		20		35	
SHL CRANE		FIXED JIB (WITH HOOK)		FULL CWT WITHOUT CBWT	
6		21		36	
SHL LUFFING		WITH FIXED JIB (WITHOUT HOOK)		LESS CWT WITHOUT CBWT	
7		22		37	
CLAM SHELL		JIB OFFSET ANGLE		ADD. CWT WITHOUT CBWT	
8		23		38	
DRAG LINE		JIB LENGTH		ADD. CWT TWO CBWT	
9		24		39	
FLOATING CRANE		BOOM LENGTH		FULL CWT TWO CBWT	
10		25		40	
SELF REMOVAL (BOOM BASE)		BOOM TOP (STD)		FULL CWT ONE CBWT	
11		26		41	
SELF REMOVAL (MAST)		BOOM TOP (LUFFING 1)		SHL WEIGHT (LARGE)	
12		27		42	
SELF REMOVAL (CWT)		BOOM TOP (LONG)		SHL WEIGHT (MIDDLE)	
13		28		43	
PICK and CARRY		BOOM TOP (LUFFING 2)		SHL WEIGHT (SMALL)	
14		29		44	
SIMULTANEOUS HOIST		BOOM TOP (LIGHT)		SELF REMOVAL (BOOM BASE 2)	
15		30		45	
PILE DRIVER		BOOM TOP (HEAVY)		SELF REMOVAL (MAST 2)	

46	 1
HOOK 1	
47	
HOOK 2	 2
48	
HOOK 3	 3
49	
FRONT DRUM IN USE	
50	 RE
REAR DRUM IN USE	
51	 3RD
THIRD DRUM IN USE	
52	
SINGLE DRUM	
53	
DOUBLE DRUM	
54	
CLAM SHELL (SIDE WAY PULL POSSIBLE)	
55	
CLAM SHELL (NO SIDE WAY PULL)	
56	
WITH HOOK POCKET	
57	
WITHOUT HOOK POCKET	
58	
SHL WEIGHT RADIUS	
59	
CWT (VERTICAL 4)	
60	
FULL CWT ONE CBWT	

61	
WITHOUT CWT	
62	
WITHOUT THIRD DRUM	
63	
DOUBLE DRUM WITH THIRD DRUM	
64	
DOUBLE DRUM WITHOUT THIRD DRUM	
65	
SELF REMOVAL (SHL MAST)	
66	
WITH POINT SHEAVE	
67	
WITHOUT POINT SHEAVE	
68	
JIB (WITH AUX. SHEAVE)	
69	
STOP	
70	
ALARM	
71	
CRAWLER FULL EXT.	
72	
CRAWLER MID EXT.	
73	
CRAWLER FULL RET.	
74	
FIXED JIB CRANE	
75	
LUFFING CRANE	

76	
TOWER CRANE	
77	
SHL MAST RADIUS	
78	
LESS CWT ONE CBWT	
79	
MAST CONTROL (1)	
80	
MAST CONTROL (2)	
81	
SELF REMOVAL (CBWT)	
82	
SELF REMOVAL (CWT PILE UP)	
83	
SELF REMOVAL (MAST 3)	
84	
SELF REMOVAL (BOOM BASE 3)	
85	
86	
87	
88	
89	
90	

3

2. Setting example

Attachment type	Crane
Boom length	90 feet
Jib type	Aux. sheave
Main, Aux. hook	Main hook = Use Aux. hook = Use
Number of part of line	Main hook = 4 Aux. hook = 1

Select in order from (1) to (7).

If input item is in error, press  icon to return to the previous screen.

- (1) Attachment select screen is displayed.
Select "2 (Crane Boom)".

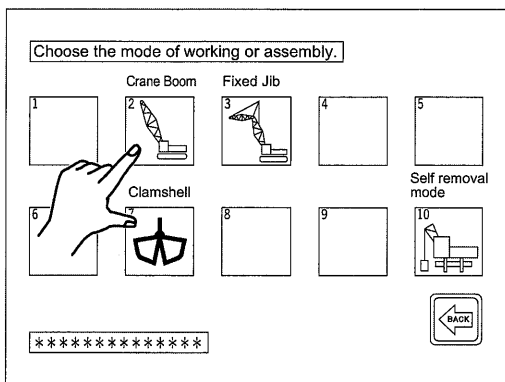

- (2) Weight select screen is displayed.
Select "2 (STD. Weight)".

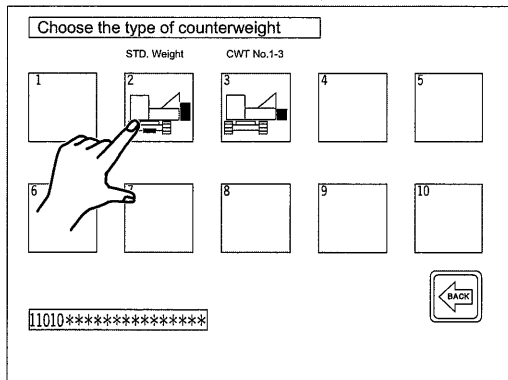

- (3) Boom length select screen is displayed.
Select "90 feet".

Choose the length of the boom.



50 feet	150 feet	
60 feet	160 feet	
70 feet	170 feet	
80 feet	180 feet	
90 feet	190 feet	
100 feet	200 feet	
110 feet	210 feet	
120 feet	220 feet	
130 feet	230 feet	
140 feet		

1101010000*****



3

- (4) Aux. sheave select screen is displayed.
Select "Aux. sheave".

Choose the auxiliary sheave.



Un-use		
Aux. sheave		

1101010000090*****



- (5) Main hook select screen is displayed.
Select "Use".

Choose a hook for front drum.



Un-use.
Use.

11010100000900100***



- (6) Aux. hook select screen is displayed.
Select "Use."

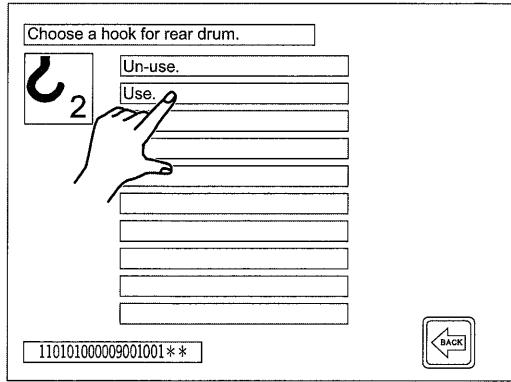

- (7) Finally number of part of line input screen is displayed.
Input "4" into Main and "1" into Aux.

- (A) Press "0" in the front drum number of part of line setting.

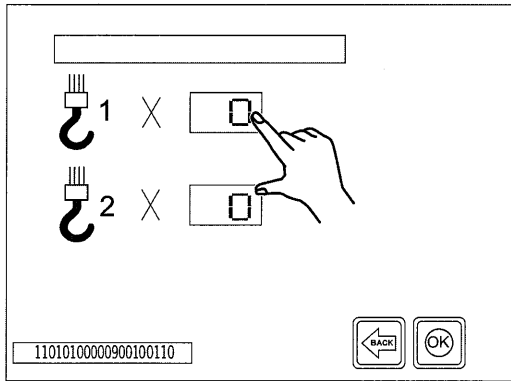

- (B) Press "4".

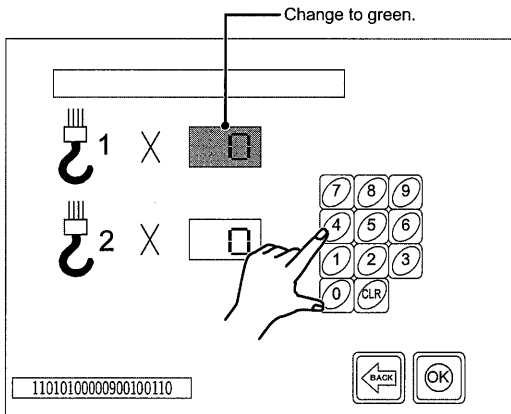

(C) Press "0" in the rear drum number of part of line setting.

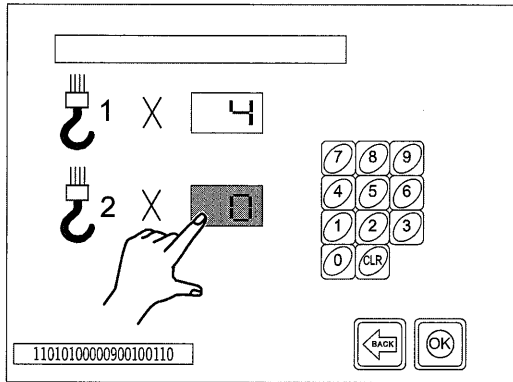

(D) Press "1" by the number pad.

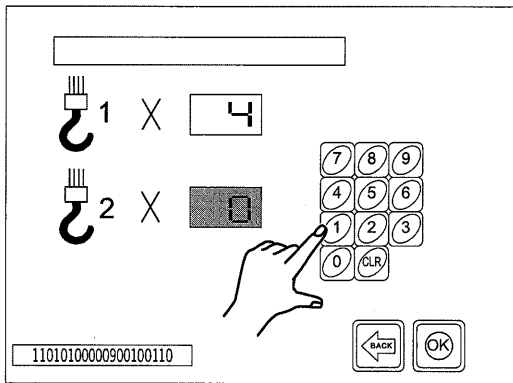

(E) Press .

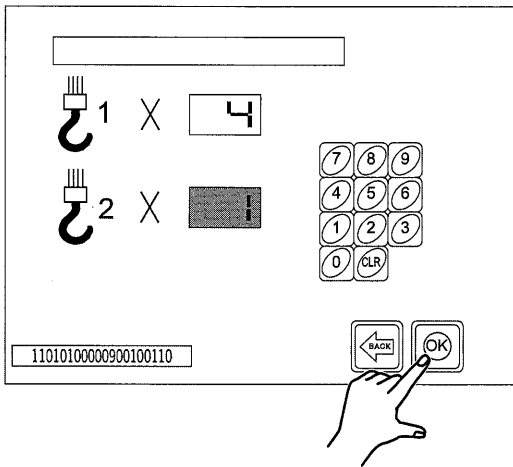

(F) Data is being searched.

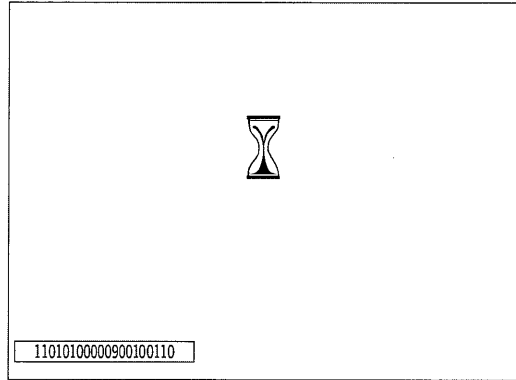

(G) Check if the selected items are correct.

If correct, press .

The screen returns to main screen.

If not correct, press .

Then screen returns to "(1) attachment select screen" and start re-input.

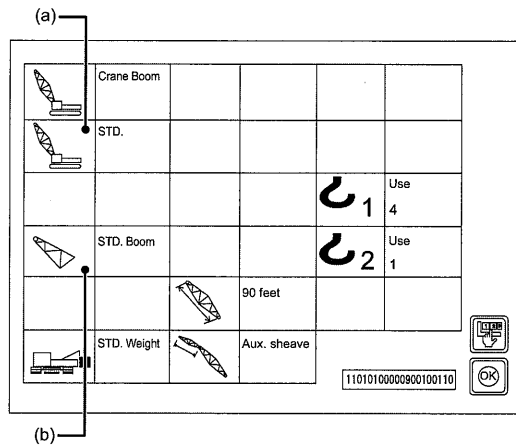

Note

In case the selection is limited to only one choice, select screen is neglected and only result is indicated.

In the screen example, they are (a) to (b).

SETTING CONFIRMATION

When all select and input are completed, the screen returns automatically to main screen.

However the setting is in correct, error message screens are displayed.

Note

If error occurs, after all settings are completed. Corresponding data reading starts by the monitor. If corresponding data is in correct, an error message will be displayed and a buzzer sounds. Press  icon and reset. Check for equipped attachment and start resetting.

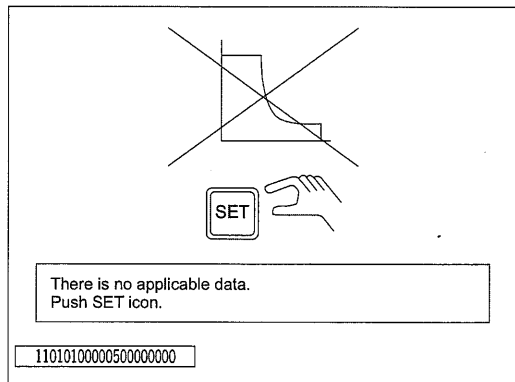

If the data in the data card can not be read out, the following screen will be displayed.
Contact the KOBELCO authorized service shop.

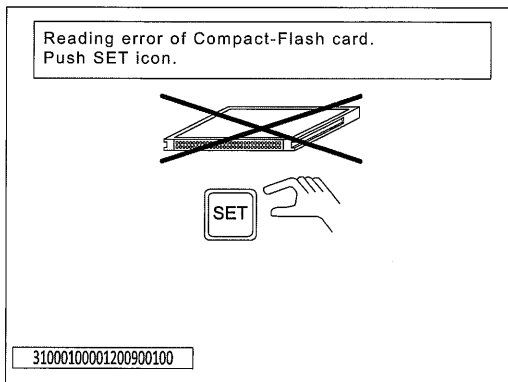

3.5.2 SELECTION OF MAIN LIFTING / AUXILIARY LIFTING

⚠ DANGER

Check always if the crane configuration is properly set to avoid a serious accident.

In case both of main hook (front drum) and auxiliary hook (rear drum) are equipped, ensure to select main lifting (front drum) or auxiliary lifting (rear drum) based on actual hook being used to change capacity. Selecting procedure is as follows.

Press figure of actually used hook for work.
Selected hook is indicated brightly and non selected hook is indicated semi transparently.

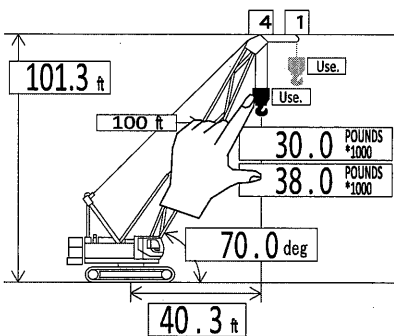

Main lifting selection

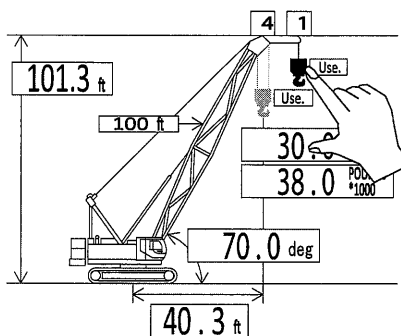

Aux. Lifting selection

3.5.3 SETTING OF WORK AREA LIMIT VALUE

In case of work requiring area limitations, the work area limiting function can be utilized for upper and lower boom angle limits, maximum load, maximum work radius, and maximum height.

(Work area limiting function)

As for items other than maximum load, pre-notice point and stop point can be individually set.

When only stop point is set, pre-notice would be issued on the specified point. (See table below)

When the boom comes closer to the pre-notice point, intermittent sound is issued and continuous sound is issued to the stop point.

Operation toward danger side is auto-stopped.

As for intermittent and continuous sound are issued only when operated toward danger side.

Even when the machine reaches to each limit value, the operation lever is in neutral position (or toward safe side) sound is not issued.

Symbol	Limit item	Setting unit	Pre-notice point
A	Boom upper/lower angle limit value	Set with 0.1 degrees unit	5 degrees before (in case pre-notice point is not set)
B	Lifting load limit value (front and rear drum)	Set with 100 pounds unit	90%
C	Work area limit value (front and rear drum)	Set with 0.1 feet unit	1 feet before (without pre-notice point)
D	Max. height limit value	Set with 0.1 feet unit	1 feet before (without pre-notice point)
E	Jib upper/lower angle limit	Set with 0.1 degrees unit	5 degrees before (without pre-notice point)

A to E above can be set at the same time (multiple setting).

Set value memorized until changed even if the power is cut.

Intermittent sound is issued before reaching limit value and if limit value is exceeded, continuous sound is issued and machine is auto-stopped.

1. SETTING

- (1) With the main screen being on the indication area, press  icon.
Menu screen is displayed.

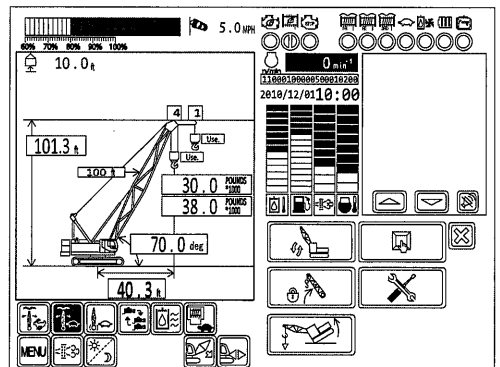
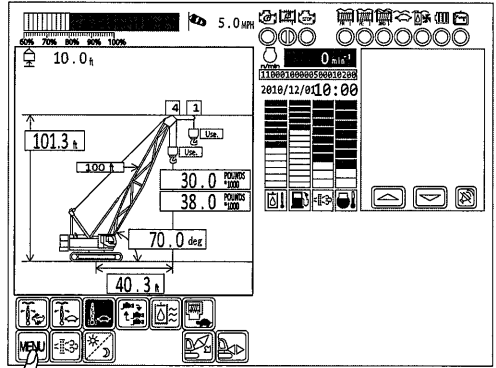

- (2) Press  in the menu.

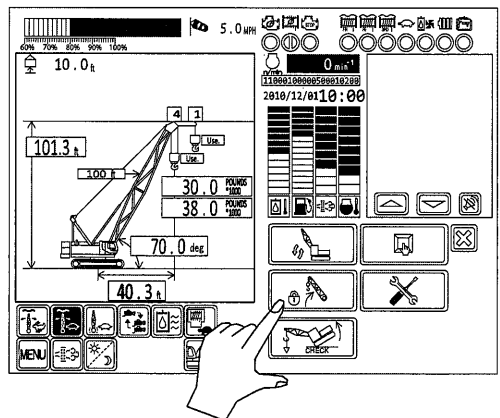

- (3) Work area limit setting screen is displayed. (The screen example is crane case.)
Press the figure area if new setting is required.

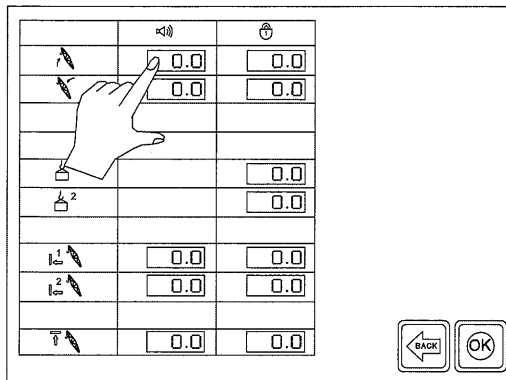

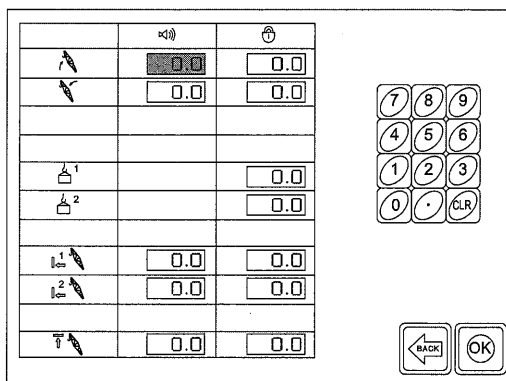

Number pad is displayed on right part of the screen.

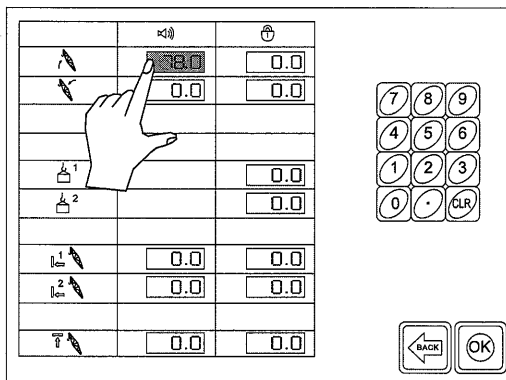

- (4) Setting method
(Ex.) In case of boom upper limit angle
(Pre-notice point) setting

- Raise the boom to the angle where pre-notice is required to issue.
- Press the figure area of the boom upper limit angle (pre-notice point).
- Indicated value is the present boom angle.



- If fine adjustment is required, input value with the number pad.
- If the present value is correct, no action is required.
- When figure is decided, press  icon.
- This is to complete the work area setting.
- * If other item needs to be changed, set the other items in the same way before pressing .

On items where the area limit setting is completed, figure area becomes yellow highlighted when the crane enters into the pre-notice zone and corresponding message code is indicated.

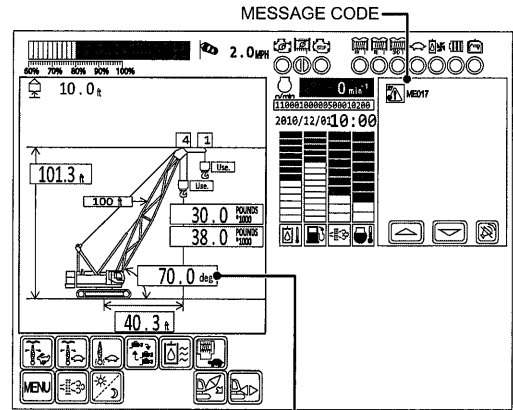

YELLOW HIGHLIGHTED AREA

When the load limit is input, the rated load indication area becomes reverse indication (green background/black letters).

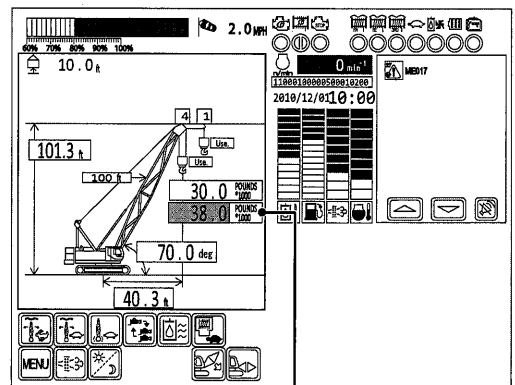

REVERSE INDICATION

- Max height can not be set individually for main lifting and aux. lifting.
In the main lifting mode, limit function becomes actuated when the boom point reaches to the set point.
In the aux. lifting mode, limit function becomes actuated when the jib point (or aux. jib point) reaches to the set point.
- Input of the load limit value is to be done with input of variation of value only.

Pre-notice point and alarming point (stop point)

On the item with both pre-notice and alarming points are possible to be set, pre-notice point must be set to more safety side than the alarming point.

If this rule is not followed, caution message is indicated and setting will not be accepted.

Re-setting is necessary in such case.

If cancelling becomes required during input work

Cancelling is possible right after placing the cursor on setting required item and pressing the  icon.

Pressing the  icon returns the screen to the previous one and restart is possible.

If this function is not used

If for each "0.0" is displayed, the item's limit function is OFF.

Therefore set each item as "0.0" if the item function is not to be used.

Place the cursor on "0.0" required item and press "CLR" icon to indicate "0.0".

Then press  icon.

3.6 SWING LIMITATION DEVICE (OPTION)

1. Introduction

Swing limitation device (option) is a device that allows the operator to stop the upper machinery at any preset limit position (right and left).

When machine reaches either preset limit position, the controller automatically stops the swing motion of upper machinery and prevents upper machinery from passing the swing limit position.

The operator may swing the upper machinery in the opposite direction.

This device assists contact prevention from obstacle and may not provide automatic stop function without load swing.

Ensure to stop operation with your own operation before reaching left (or right) limit position while taking indication and warning into account.

Since the crane may overrun the left (or right) limit position by its inertia, set the limit position with some allowance.

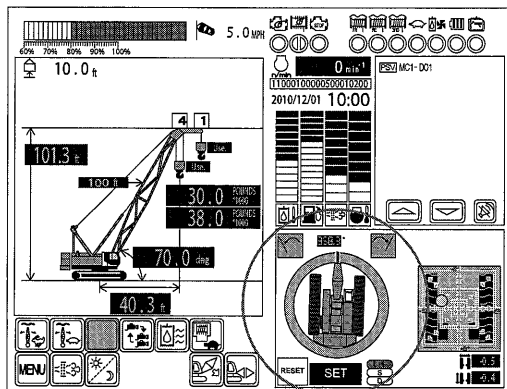

SWING LIMITATION INDICATOR

3

WARNING

Make sure to reduce the swing speed when the left (or right) limit position comes closer in order to prevent the accident by attachment damage.

Failure to observe this precaution may result in a serious accident and loss of life.

Machine equipped with this option has the monitor indication on its right lower part of screen.

2. Explanation of indicator

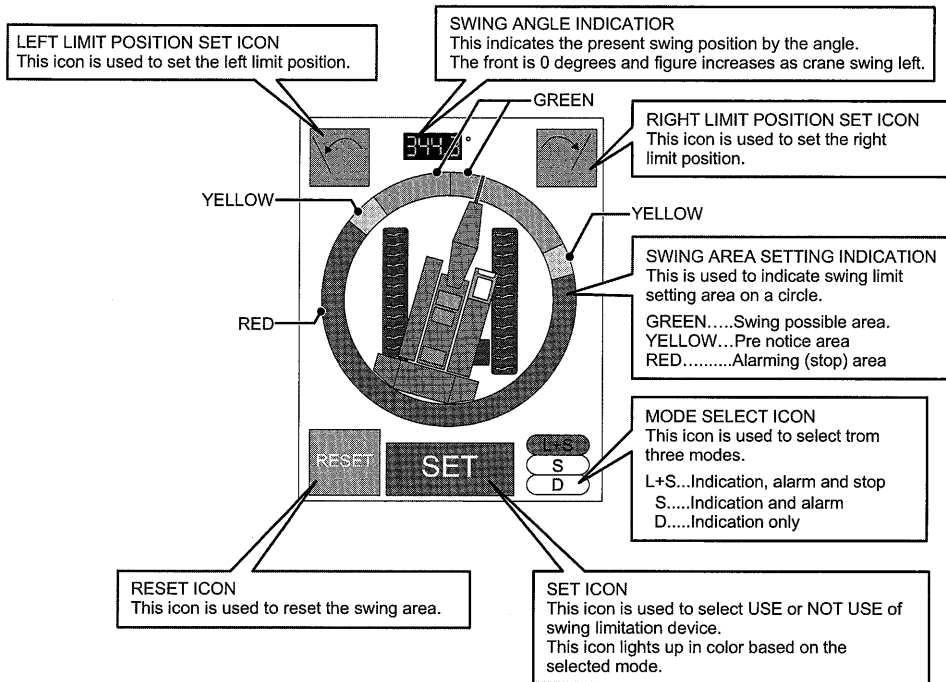

3. Mode

The following three modes are available in this device.

Select mode based on the needs.

Use mode select icon for selecting a mode.

The color of the **SET** icon can tell the current set mode.

Each mode differs as explained below (1) to (3) but setting method of limit area, resetting and function are the same to all modes.

(1) D mode

Limit area is divided to three colors (green, yellow and red) Alarming or auto-stop is not issued.

(2) S mode

Limit area is divided to three colors (green, yellow, red) In the yellow area, intermittent buzzer sound is issued and in red color continuous buzzer sound is issued.

In the yellow color area, intermittent sound pitch becomes higher as machine comes closer to red area (stop side).

(3) L+S mode

Swing speed is reduced about 1/3 of the normal swing speed.

In addition to the function of the S mode, swing motion toward to limit side stops when entered into red area.

(Ex.) When swing right, to the red area, right swing stops.

In 5 seconds after entering into red area, swing parking brake also actuates automatically.

The swing parking brake will only be released during operation toward safety side (left side in the example below) or when the crane comes out of red area.

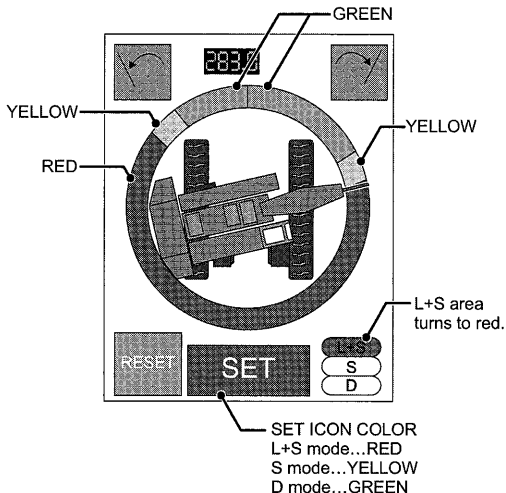

WARNING

Check the selected mode before starting the work. If the wrong mode is selected, alarming or stopping does not function properly and it may result in an accident.

Failure to observe this precaution may result in serious accident and loss of life.

If the mode is changed after the limit area is set, only the mode (function) is changed while limit area setting is the same.

Therefore limit area re-setting is not required.

4. Limit area setting method

(1) Initial setting

(A) When engine is started, screen indicates as shown below.

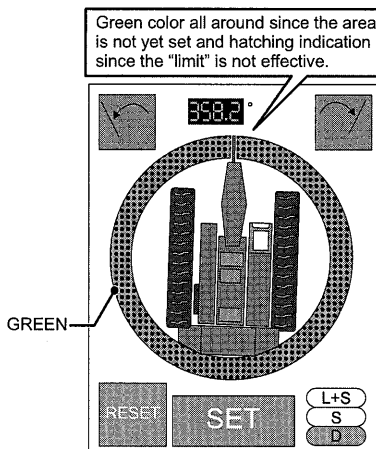



(B) Swing the crane left to the safe place just before the obstacle on the left side and stop.

Press the icon .



Since the crane may overrun the limit position by its inertia, set the limit position with some allowance.

The boom facing area changes its color to red and right next to this area to yellow.

When the position has to be adjusted after  icon is once pressed, swing to the exact position and again press  icon.

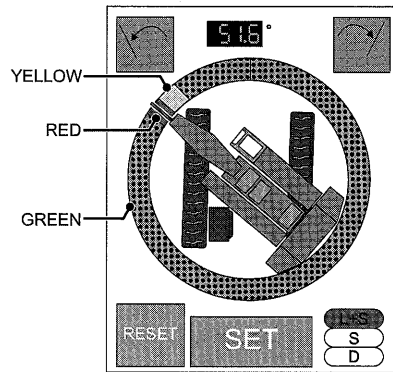
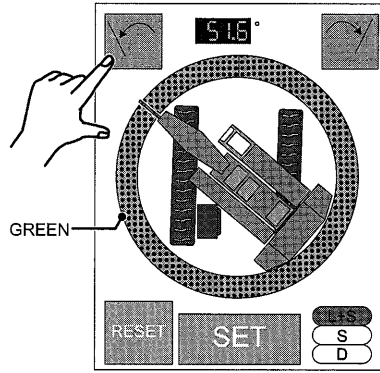
Red and yellow indication area are renewed.



- (C) Swing the crane right to the safe place just before the obstacle on the right side and stop. Press the icon . The swing area is set. When the position has to be adjusted after  icon is once pressed, swing to the new position and press  icon. Red and yellow indication area will be renewed.

Note

To set the swing area, both side same needed to be set.

In case there is no obstacle on the right side, swing the crane far enough to the position where automatic stop does not disturb crane work and press .

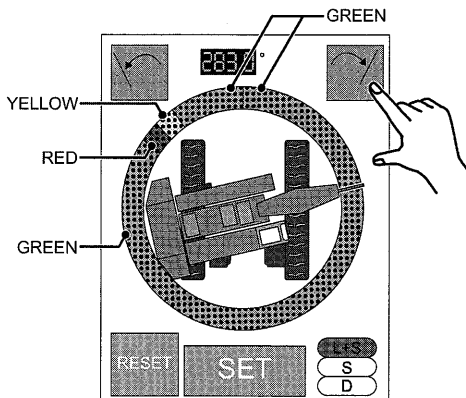

3

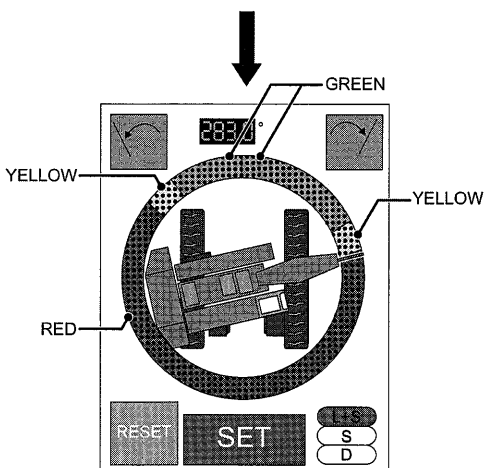

- (D) After changing the swing mode to the brake mode, press **SET** icon.
 Hatching indication on the circle disappears and setting is now completed.
 The mode selected becomes effective
 (Indication, alarming and stopping).

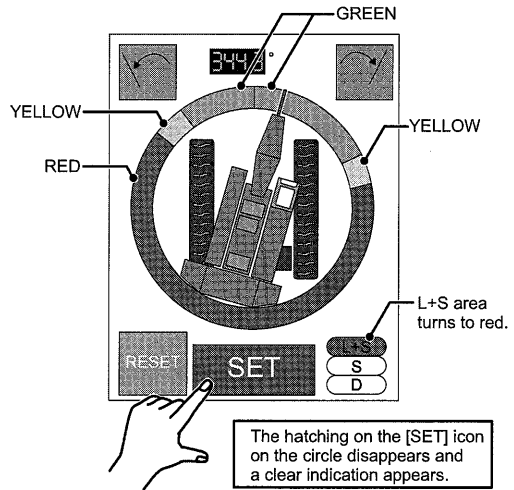

WARNING

With the hatching indication just after engine start, limit function does not work and swing motion is free.
 If the limit function is necessary, ensure to set the limit area.
 Failure to observe this precaution may result in serious accident.

Note

It is also possible to set the limit position from the right side to left side first.

Note

If **SET** icon is pressed without changing the swing mode to the brake mode, mode setting cannot be done.
 Ensure to change to the brake mode and then press **SET** icon again.

- (2) In case of restart of the engine after setting completed.
- (A) **SET** icon and the circle with hatching are displayed.

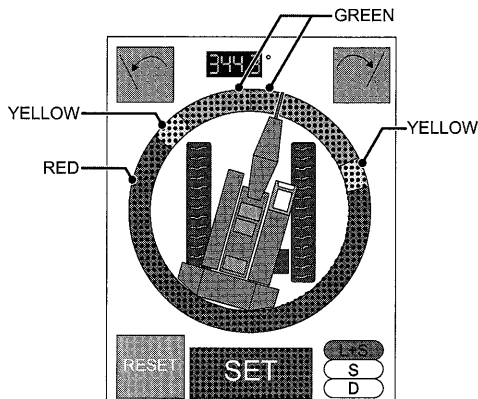

- (B) If adjustment of area is not necessary, press **SET** icon. Hatching on the **SET** icon and circle disappear and setting is completed.
- (C) To reset the area again, press **RESET** icon. The screen returns to the one shown right. Set again based on new setting procedure.

Green color all around and hatching indication, since the "limit" is not set or effective.

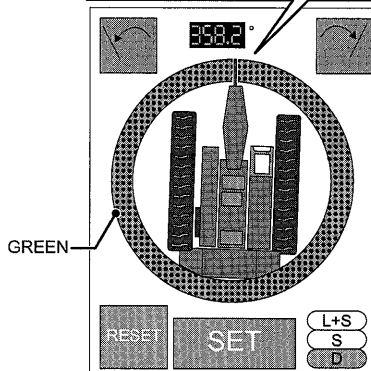

⚠ WARNING

Limit function does not work and swing motion is free with the intermitting indication just after engine start.

Where the limit function is necessary, ensure to set the limit area.

Failure to observe this precaution may result in a serious accident and loss of life.

- (3) In case crane propelled.
- (A) Right after the propel lever is operated, the screen becomes as shown right and work condition of limit function becomes cancelled.

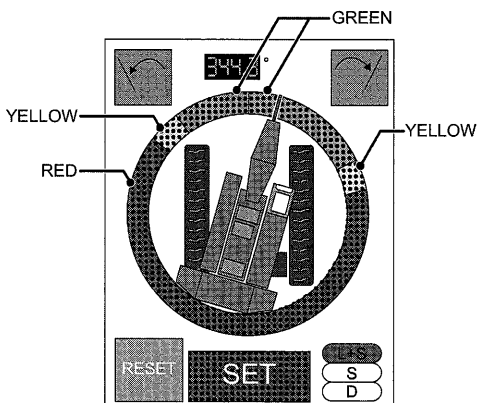



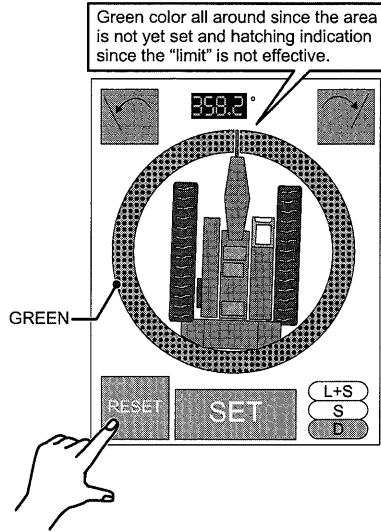

- (B) To set again, press  icon.
The screen returns to the one shown right.
Set again based on new setting procedure.

CAUTION

If the crane propels, relative position with obstacle changes.
Be sure to set again.



- (4) To temporary cancell the limits
- (A) Pressing  icon once the hatching appears on the circle and  icon, and the swing area limit function (alarm and stop) is cancelled and swing motion becomes free.
- (B) In order to resume limit function, press  icon once.  icon indication and hatching on the circle become clear and the limit function becomes effective.

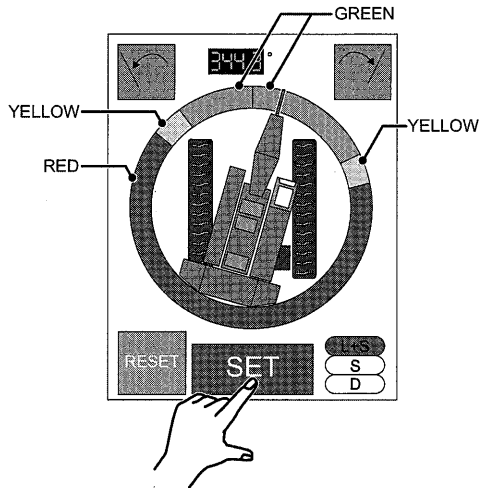

5. Function

Function of L+S mode is explained here as an example.

- (1) Figure below shows that the crane is in safe area after setting a limit area.
- (2) From this condition, if the crane swings to the right, crane figure turns right.

* Only in case of L+S mode, swing speed is reduced to 1/3 of normal speed to reduce shock at the time of stop.

- (3) If the crane continues to swing right and the tip of the boom enters into yellow color area in the circle, intermittent alarm sound is issued. Slow down swing speed by low engine speed or adjusting swing the lever etc. Intermittent warning sound becomes higher pitch as the crane comes closer to the red color area. Intermittent alarm range is 10 degrees.

- (4) If the crane continues to swing further and the tip of the boom enters into red area on the circle, continuous alarm sound is issued and swing motion stops.

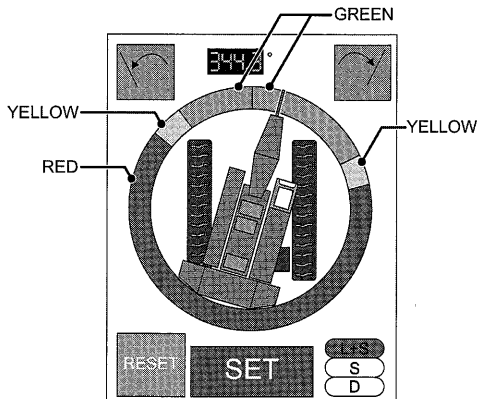

3

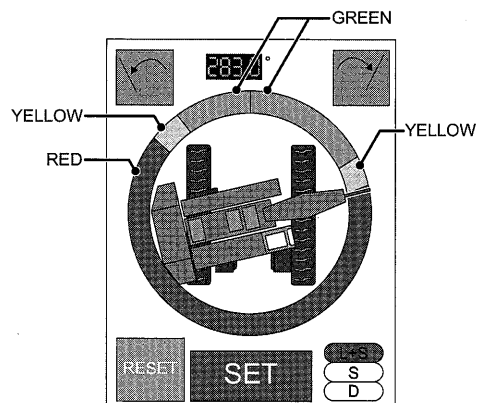
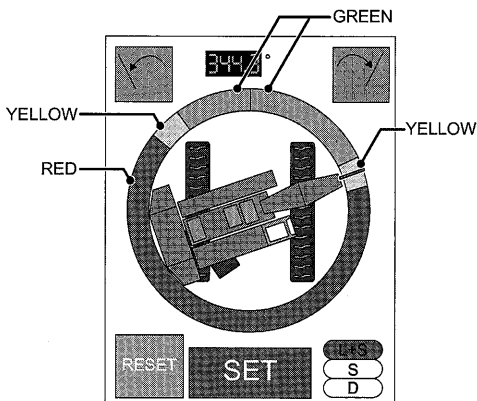

- (5) After swing motion stops, swing left to return the crane to safe area (green area) immediately.

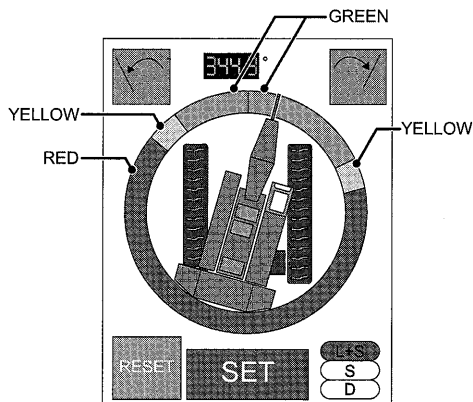

- (6) If the crane swing to left, directions (1) to (5) become opposite.

* Caution on indication

Issuing timing of intermittent alarm and continuous alarm (timing of auto-stop) may slightly shift from the timing when the color on circle changes (green to yellow, yellow to red). Therefore operate the crane with some allowance.

3.7 FUNCTION OF GROUND INCLINE INDICATOR (OPTION)

1. Introduction

This device is to detect inclination of the ground to indicate and issue warning.
 Improve ground condition enough for crane work so that warning from this device will not be issued.



Periodical check should be made to obtain error between actual indicated value and the level gauge at crane lower frame.
If the error becomes large, adjustment is necessary.
 Contact KOBELCO service shop.

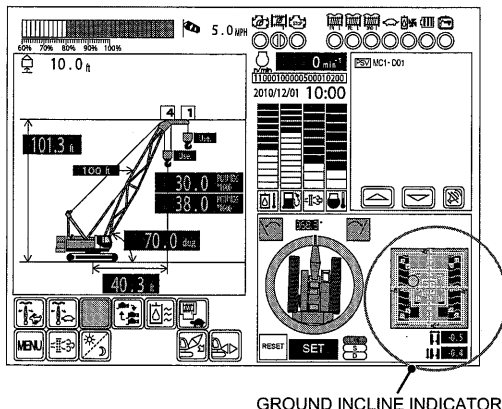

GROUND INCLINE INDICATOR

Machine equipped with this option has the monitor indication on its right lower part of the screen.

2. Indicator

The above figure indicates example of condition that right rear side is lower.

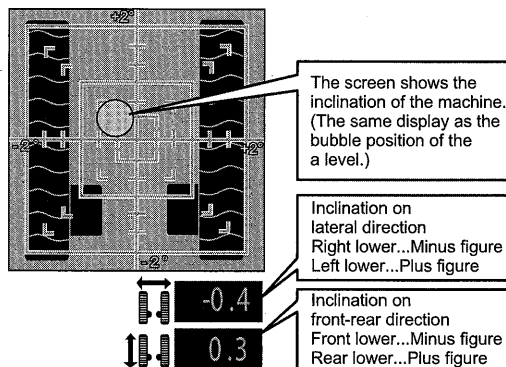

3. Display and action at danger

The above figure indicates example of condition that right rear part is lower.
 Either the front or rear indication exceeds ± 0.5 degrees, warning is indicated.
 This function issues only indication and the crane work will not stop.
 Check the crane condition and press **OK** button.
 Warning indication disappears.
 If indication appears before starting work or without load lifting, ground improvement is recommend.
 Improve the ground so that the indication becomes within ± 0.5 degrees.

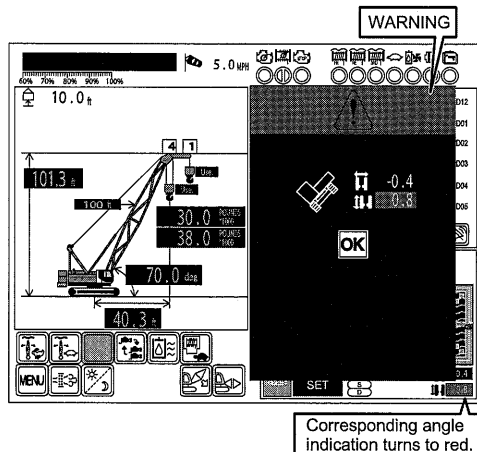

3.8 LOAD HISTORY (DATA LOGGER)

This machine is provided with the recording function of the machine condition in order to make investigation when necessary.

3.9 ALARMING AND AUTO-STOP

3.9.1 CONTENT OF ALARM AND AUTO-STOP

When the machine condition becomes closer to danger situation, alarm is issued and machine stops automatically. (See table below)

When the machine stops automatically, operate the machine toward safety side immediately.

3

CRANE

Hazardous conditions	Indication, Stop											
	Color change in indicator								Code display *2	Buzzer		Auto-stop
	Boom angle	Load ratio	Actual load	Rated load	Work radius	Hook	Boom	Back-stop		Overload warning buzzer	Overhoist warning buzzer	
(1)	(2)	(3)	(4)	(5)	(6)	(7)	(8)					
Load ratio more than 90%	—	Yellow	—	—	—	—	—	—	ME024	Intermittent	—	—
Load ratio more than 100%	—	Red	—	—	—	—	Red	—	ME005	Continuous	—	Stop
Main hook overhoist	—	—	—	—	—	Red	—	—	ME017	—	Continuous *1	Stop
Aux. hook overhoist	—	—	—	—	—	Red	—	—	ME017	—	Continuous *1	Stop
Boom overhoist	Red	—	—	—	—	—	Red	—	ME008	—	Continuous *1	Stop
Boom overhoist (Limit)	Red	—	—	—	Red	—	Red	Red	ME021	—	Continuous	Stop
Boom overhoist (Backstop No.2)	Red	—	—	—	Red	—	Red	Red	ME060	—	Continuous	Stop
Boom overlowering	Red	—	---	0.0	Red	—	Red	—	ME007	Continuous	—	Stop

*1 Only when operated toward danger side.

*2 See this article "3.13 MESSAGE TABLE" detail of display code.

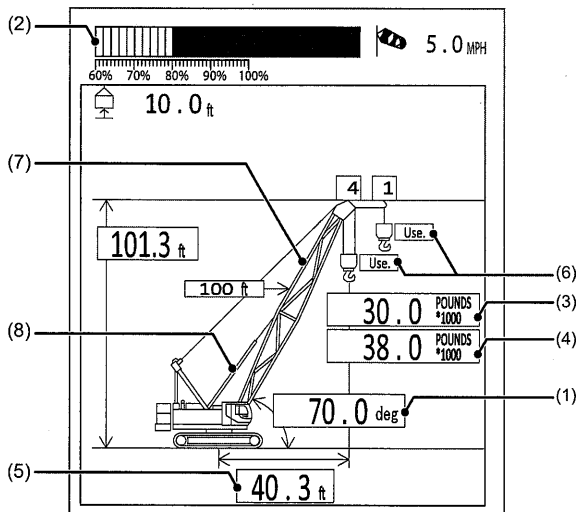

3.9.2 CONTENT OF AUTO-STOP

When the machine stops on each danger condition, machine does not move to × direction on the following figures.

Direction without × mark is safety side and machine moves without handling the release switch.

Whenever machine auto-stops, operate the machine toward safety side immediately.

1. IN CASE OF CRANE

(1) Overload

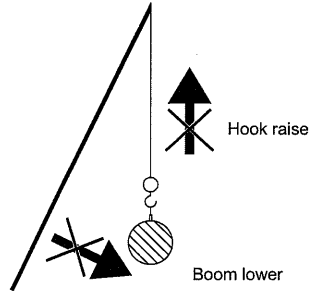

(2) Hook overhoist Boom overlowering

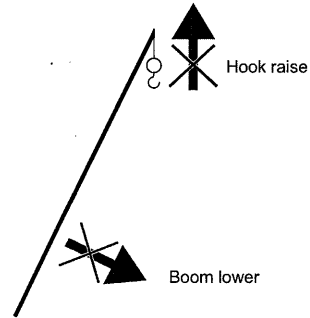

(3) Boom overhoist

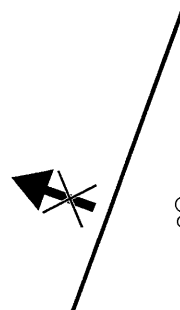

(4) Boom overhoist
(Final stop limit switch control)

Normally when boom overhoist occurs, controller functions to stop automatically.
If auto-stop function is being released and operated, the final stop limit switch control becomes actuated and machine auto-stops.
In this case, auto-stop can not be released.

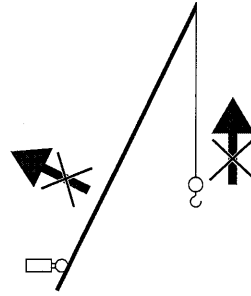

3.9.3 RELEASING AUTO-STOP

⚠ DANGER

Never operate the crane with the auto-stop release switch turning to "RELEASE" side.

Failure to observe this precaution may result in serious accident.

⚠ DANGER

Never use the auto stop release switch for other than maintenance purpose.

Failure to observe this precaution may result in a serious accident.

1. Auto-stop release switch

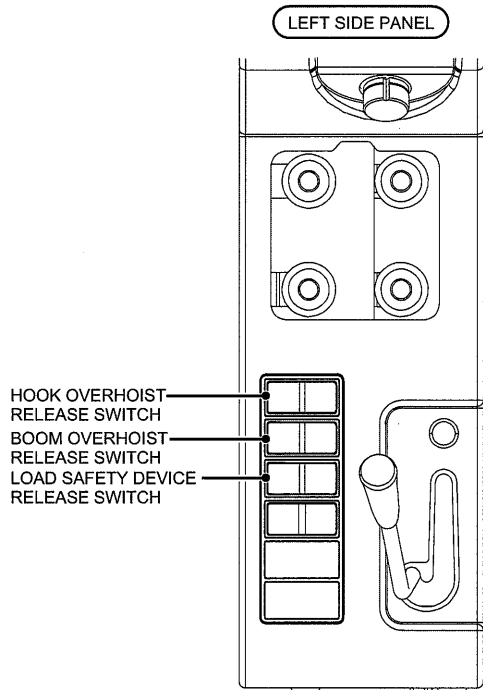

2. Handling procedure of auto-stop release switch

Use this switch only when auto-stop function must be released and crane operation must be continued such as emergency or maintenance work.

When the switch (2), (3), (4) is operated, release switch master key (1) must be turned to "RELEASE" position.

(1) RELEASE SWITCH MASTER KEY

This switch controls the auto-stop release function of overload, boom overhoist and hook overhoist.

The key can be pulled out at "LOCK" position.

Auto-stop release function by the release switch does not work at "LOCK" position and works only at "RELEASE" position.

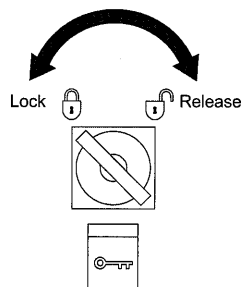

CAUTION

Follow the instruction of work controller for the release master key control during work.

(2) LOAD SAFETY DEVICE RELEASE SWITCH

This switch can release auto-stop function at overload condition or at work radius exceeding condition.

By turning the switch to "RELEASE" side, auto-stop can be released.

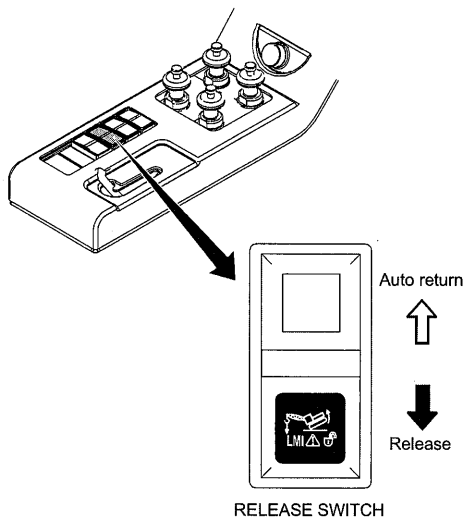

(3) BOOM OVERHOIST RELEASE SWITCH

This switch can release auto-stop function when boom overhoist or jib overhoist occurs.
By turning the switch to "RELEASE" side, auto-stop can be released.

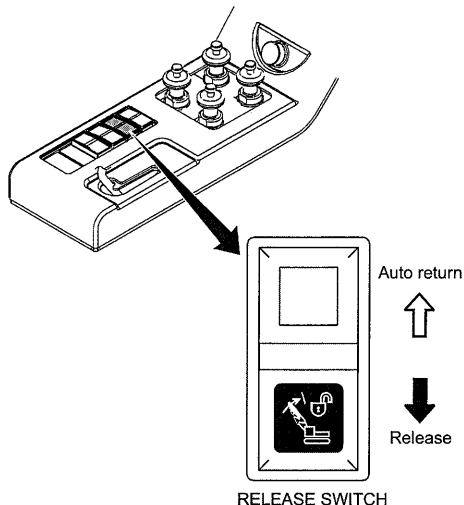

(4) HOOK OVERHOIST RELEASE SWITCH

This switch can release auto-stop function when hook overhoist occurs.
By turning the switch to "RELEASE" side, auto-stop can be released.

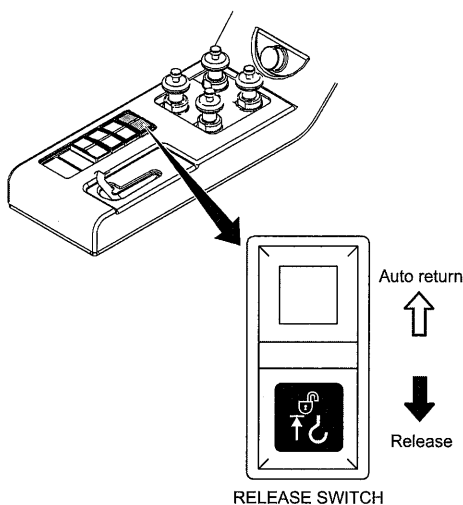

CAUTION

When auto-stop function is to be released, hold the switch to release side with hand.

When hand is freed, switch returns to neutral and auto stop function resumes.

CAUTION

When the auto-stop function is to be released, ensure to use the corresponding release switch. Using the other release switch can not release the required function.

3. Handling at boom stowing

- (1) Lower the boom until auto-stop occurs.
- (2) When the crane auto-stops, press  (boom, jib lowering icon) in the monitor for more than 1 second.

The crane is turned to boom lowering mode and auto-stop is released and boom lowering becomes possible.

- (3) However when the weight of hook overhoist limit switch contacts the ground, auto-stop occurs due to hook overhoist preventive device.

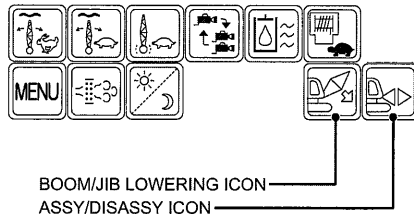

- (4) To lower the boom further, return the control lever to neutral once and press  (assy/disassy icon) for one time (1 second).

Then the crane turns to Assy/disassy mode and auto-stop due to hook overhoist is released and boom lowering becomes possible.



3

Note

Press ,  (boom, jib lowering icon) for more than 1 second.

MESSAGE

ME007

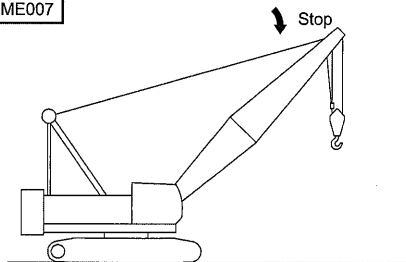

MESSAGE

ME017

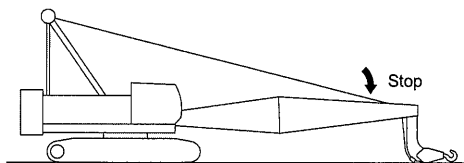

4. Auto-stop releasing at boom assembly of disassembly work

When load safety device, angle detector or hook overhoist limit switch are not connected such as main machinery or attachment assembly or disassembly work, auto-stop due to load safety device or hook overhoist preventive device occurs or alarm is issued.

By pressing  icon, load safety device turns to Assy/disassy mode and auto-stop and alarm sound are released.

When crane turns to Assy/ disassy mode, load safety device indication becomes only boom angle indication and caution message indication.

After assembly/disassembly work is completed and boom is to be erected, press  icon once again.

Then the crane turns to work mode.

If the boom is erected without changing to work mode, crane is turned to work mode automatically when the boom angle exceed about 15 degrees (for tower 40 degrees).

Therefore when the boom is erected, crane does not turn to Assy/disassy mode even pressing the icon.

Assy/disassy mode is cancelled when the main key switch is turned to "OFF" position.

Therefore ensure to press  icon again whenever the main key switch is turned ON.

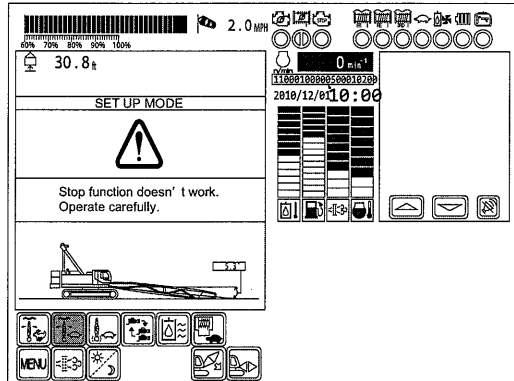

Note

Press  icon for more than one second.

Note

When the boom is erected or a load is applied on the load cell, the mode does not change to Assy/ disassy mode.

5. Stop release mode when transportation with boom base attached.
(Only machine with reduced weight specification)

For machine with the reduced weight specification, counterweight is not installed during transportation.

Therefore the machine becomes transportation mode unless the machine is out of the work mode applicable range shown in "4. Auto-stop releasing at boom assembly of disassembly work" and crane work configuration, tower work configuration.

When the machine becomes transportation mode, the monitor of the load safety device displays message requesting weight installation, detector connection and angle display.

Under the transportation mode, front drum, rear drum and third drum winches become auto-stop condition for both raising and lowering motion and only boom drum becomes functional for raising and lowering.

Machine can move to other mode either by lowering boom angle to work mode range shown in "4. Auto-stop releasing at boom assembly of disassembly work" or by installing the required counterweight and connecting the detector.



3

Note

If the counterweight detector is removed under the crane work configuration (or under tower work configuration), the machine becomes all stop condition rather than transportation mode.

When the machine becomes under all stop condition, install the weight detector to make machine to safe disassembling condition and then remove the weight detector.

3.10 INSPECTION

3.10.1 INSPECTION PROCEDURE WHEN RAISING THE BOOM AFTER THE ATTACHMENT ASSEMBLY WORK IS COMPLETED

After attachment assembly work is completed, check the function of safety related device and make sure that there is no abnormality before raising the boom.

At checking work, limit switch may have already actuated.

Pull the limit switch once and set it to safety condition and then inspect as follows.

CRANE ATTACHMENT

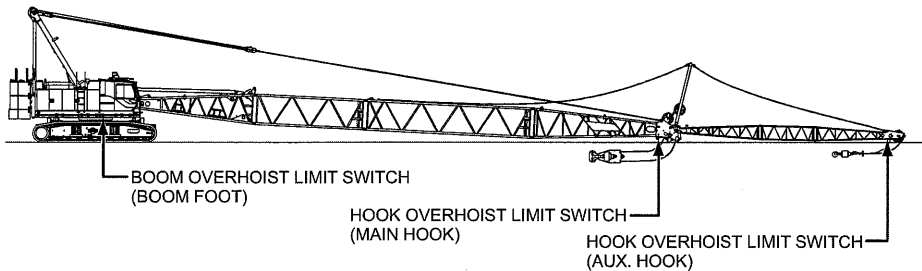

- Inspection of boom overhoist limit switch

Press the boom foot right limit switch roller by hand and check that the "boom figure" "boom backstop figure" in the indication area of "boom angle" "work radius" turns to red color and message "ME021" in the message display area.

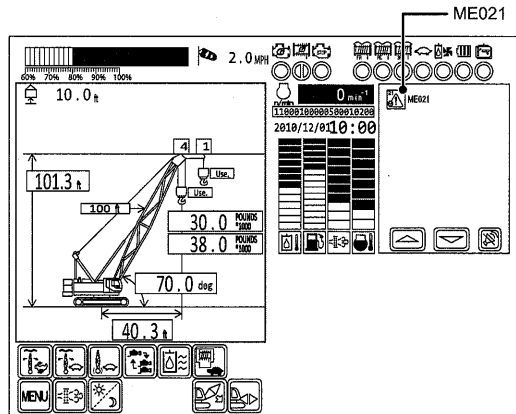

- Inspection of main hook overhoist limit switch

Lift up the limit switch weight rope and check that the hook figure in the display turns to red color and the message “ME017” in the message display area.

Pull down the rope by hand and check that this message is displayed.

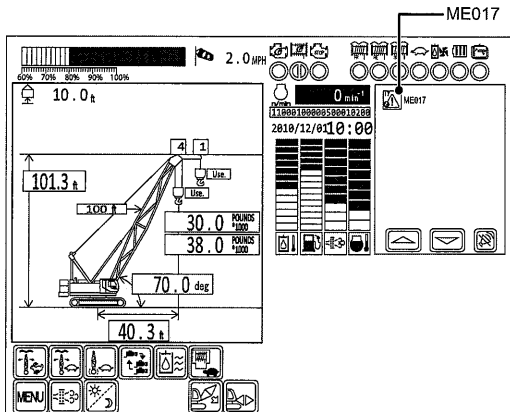

3

- Inspection of aux. Hook overhoist limit switch

Lift up the limit switch weight rope and check that the hook figure in the display turns to red color and the message “ME017” in the message display area.

Pull down the rope by hand and check that this message disappeared.

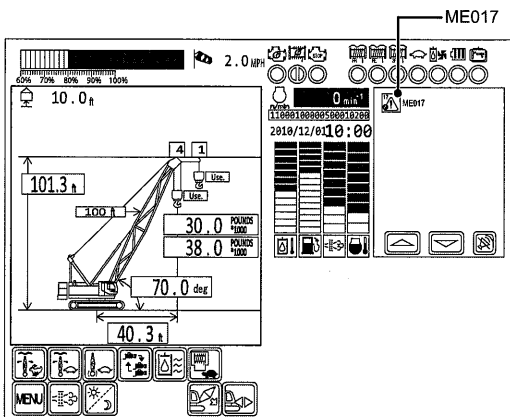

3.10.2 INSPECTION AFTER ERECTING ATTACHMENT

Check to see that there is no abnormality of auto-stop, alarming functions and display indication.

Auto-stop angle on boom overhoist side is as shown on the next table.

Auto-stop angle on boom overlowering side (work radius exceeding) varies depending on boom length.

Attachment	Type of overhoist	Stop type	Auto-stop angle
Crane	Boom overhoist	Controller (angle against ground)	78 degrees to 81.4 degrees
		Limit switch (angle against machine)	83.5 degrees to 84.5 degrees

- Inspection of overload (load safety device) with the monitor

If it is difficult to test auto-stop function due to overload by lifting the actual load, check can be done in the display.

Perform this test in "WORK" position.

The test will not work in assembly/disassembly mode.

- (1) Press **MENU** icon to indicate menu and press **CHECK** icon.

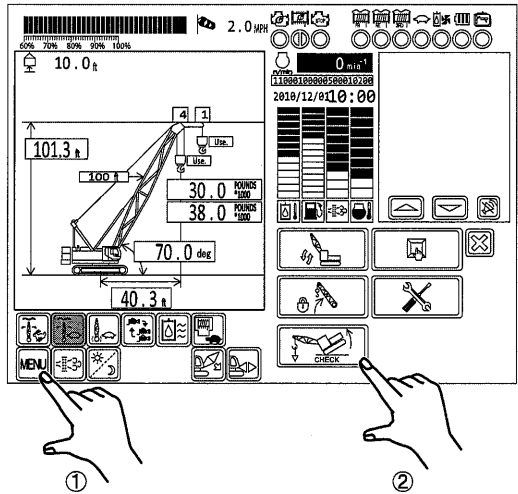

- (2) Press **ON** icon.

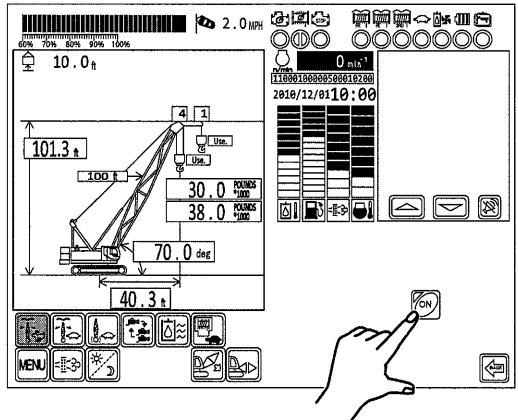

- (3) The crane turns to the simulated overload condition and auto-stop occurs.

(Overload check mode)

Check to see that hook raising or boom lowering can not be done.

During check mode, message "ME056" appears in the message area.

- (4) After motion check, press  icon. Check mode is completed.

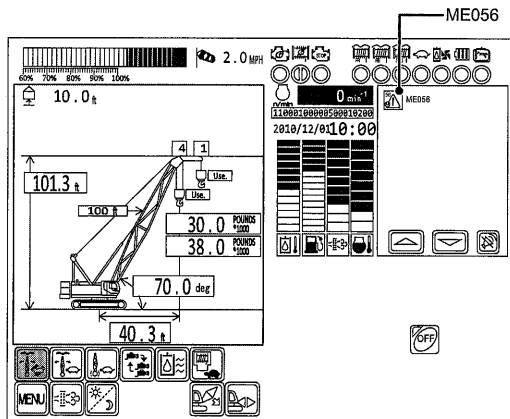

3.11 CAUTIONS IN HANDLING LOAD SAFETY DEVICE

1. Welding work

When welding to machine, stop the engine and turns the key switch to OFF.

For further, disconnect all the connectors on the backside of the monitor and controller.

2. Radio wave interference

If the radio wave interference is received from the near radio station, contact KOBELCO service shop.

3. Static electricity interference

If the monitor surface is rubbed strongly with dry nylon cloth etc. static electricity may be generated.

This static electricity has harmful effect to the monitor function.

Do not rub strongly.

3.12 ERROR CODE AND MESSAGE

When abnormality occurs, its error code is indicated in the message indication area and buzzer sounds.

- Buzzer can be stopped by pressing the buzzer stop icon in the message indication area. In addition when error code of the load detector or angle detector appears, the machine stop automatically.
- The display indicates the code as listed below.

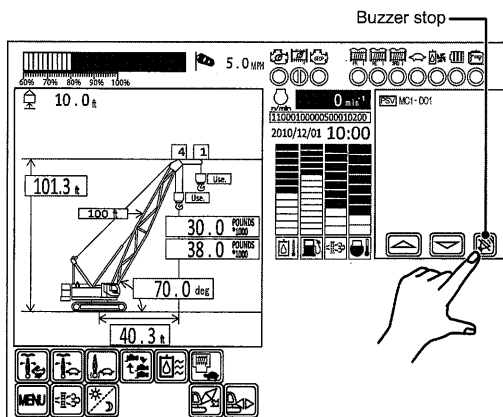

Note

The table includes all codes.

There are no some codes which are not displayed based on models.

Code	Message
P0045	VNT actuator failure.
P0047	VNT solenoid valve 1 low voltage
P0048	VNT solenoid valve 1 high voltage
P0049	Turbo charger revolution overrun
P0087	Common rail pressure control failure.
P0088	Common rail pressure control failure.
P0096	Intake air temperature sensor (intake manifold) - rationality
P0097	Intake air temperature sensor (intake manifold) - out of range (Out of range low)
P0098	Intake air temperature sensor (intake manifold) - out of range (Out of range high)
P00AF	VNT actuator failure.
P0102	Air-flow sensor failure (Low)
P0103	Air-flow sensor failure (High)
P0104	Air flow sensor - out of range
P0108	Boost pressure sensor - out of range (Out of range high)
P0112	Intake air temperature sensor (air flow sensor built-in) - out of range (Out of range low)
P0113	Intake air temperature sensor (air flow sensor built-in) - out of range (Out of range high)
P0117	Engine coolant temperature sensor - rationality
P0118	Engine coolant temperature sensor - out of range (Out of range low)
P0122	Intake throttle valve-opening sensor 1 out of range (Out of range low)
P0123	Intake throttle valve position sensor 1 - out of range (Out of range high)
P0182	Fuel Temp. sensor failure (Low)
P0183	Fuel Temp. sensor failure (High)
P0187	Fuel Temp. sensor failure (Low)
P0188	Fuel Temp. sensor failure (High)

Code	Message
P0191	Common rail pressure sensor malfunction
P0192	Common rail pressure sensor (main) - out of range (Out of range low)
P0193	Common rail pressure sensor (main) - out of range (Out of range high)
P0197	Common rail pressure sensor (aux.) - out of range (Out of range low)
P0198	Common rail pressure sensor (aux.) - out of range (Out of range high)
P0200	Engine ECU failure.
P0201	Fuel injector - disconnection (#1cyl)
P0202	Fuel injector - disconnection (#2cyl)
P0203	Fuel injector - disconnection (#3cyl)
P0204	Fuel injector - disconnection (#4cyl)
P0205	Fuel injector - disconnection (#5cyl)
P0206	Fuel injector - disconnection (#6cyl)
P0217	Overheat
P0219	Engine overrun
P0234	Turbocharger over boost
P0237	Boost pressure sensor - out of range (Out of range low)
P0263	Correction quantity of cylinders #1 error
P0266	Correction quantity of cylinders #2 error
P0269	Correction quantity of cylinders #3 error
P0272	Correction quantity of cylinders #4 error
P0275	Correction quantity of cylinders #5 error
P0278	Correction quantity of cylinders #6 error
P0335	Crankshaft position sensor - disconnection
P0336	Crankshaft position sensor - rationality
P0340	Camshaft position sensor - disconnection
P0341	Camshaft position sensor - rationality
P0401	EGR low flow
P0402	EGR high flow
P0404	EGR valve 1 stick
P0405	EGR lift sensor 1 circuit low input
P0406	EGR lift sensor 1 circuit high input
P0407	EGR lift sensor 2 circuit low input
P0408	EGR lift sensor 2 circuit high input
P0489	EGR solenoid 1 malfunction
P0490	EGR solenoid 1 malfunction
P0524	Engine oil pressure Too Low
P0540	Preheat circuit malfunction
P0545	Exhaust temp. sensor failure (Upper stream) (Low)
P0546	Exhaust temp. sensor failure (Upper stream) (High)
P0605	Flash ROM error
P0606	CPU malfunction (Hardware detection)

Code	Message
P0607	Monitoring IC malfunction in CPU
P0611	ECU charge circuit malfunction
P0617	Starter switch - rationality
P0628	Suction control valve for fuel supply pump - circuit (Circuit low)
P0629	Suction control valve for fuel supply pump - circuit (Circuit high)
P0642	ECU sensor supply 1 failure (Low)
P0643	ECU sensor supply 1 failure (High)
P0652	ECU sensor supply 2 failure (Low)
P0653	ECU sensor supply 2 failure (High)
P0686	Main relay malfunction
P06D3	Air flow sensor power supply failure Short to GND
P06D4	Air flow sensor power supply failure (High)
P0704	Clutch switch malfunction
P0850	Neutral switch malfunction
P1062	VNT solenoid valve 2 low voltage
P1063	VNT solenoid valve 2 high voltage
P1067	VNT solenoid valve 3 low voltage
P1068	VNT solenoid valve 3 high voltage
P1071	Turbo speed sensor failure (High)
P1072	Turbo speed sensor failure (Low)
P1132	Acceleration sensor circuit low voltage
P1133	Acceleration sensor circuit high voltage
P1142	Throttle control low voltage
P1143	Throttle control high voltage
P119F	Common rail pressure sensor - rationality
P1211	Fuel injector driver circuit 1 - circuit (Circuit low)
P1212	Fuel injector driver circuit 1 - circuit (Circuit high)
P1214	Fuel injector driver circuit 2 - circuit (Circuit low)
P1215	Fuel injector driver circuit 2 - circuit (Circuit high)
P1229	Excessive supply pump pressure
P1266	Insufficient Supply pump pressure
P1401	EGR valve 2 stick
P1402	EGR solenoid 2 malfunction
P1403	EGR solenoid 2 malfunction
P1407	EGR solenoid 3 malfunction
P1408	EGR solenoid 3 malfunction
P1416	EGR cooler overheat.
P1417	EGR cooler water temp. sensor failure (Low)
P1418	EGR cooler water temp. sensor failure (High)
P1427	Differential pressure sensor - out of range (Out of range low)
P1428	Differential pressure sensor - out of range (Out of range high)

Code	Message
P1458	EGR actuator malfunction (Slight)
P1459	EGR actuator malfunction (Tertiary)
P1601	Fuel injector adjustment data abnormal
P1676	Fuel cut relay failure.
P2002	DPF system malfunction
P200C	DPF over temperature
P2032	Exhaust temp. sensor failure (2nd from upper stream) (Low)
P2033	Exhaust temp. sensor failure (2nd from upper stream) (High)
P2100	Intake throttle valve DC motor failure.
P2101	Intake throttle valve - functional
P2103	Intake throttle valve DC motor failure.
P2120	Throttle/Pedal Position Sensor/Switch D" Circuit "
P2121	Accelerator sensor 1Voltage Abnormal
P2122	Accelerator pedal position sensor 1 -out of range (Out of range low)
P2123	Accelerator pedal position sensor 1 -out of range (Out of range high)
P2126	Accelerator sensor 2Voltage Abnormal
P2127	Accelerator pedal position sensor 2 -out of range (Out of range low)
P2128	Accelerator pedal position sensor 2 -out of range (Out of range high)
P2228	Barometric pressure sensor - out of range (out of range low)
P2229	Barometric pressure sensor - out of range (out of range high)
P244A	DPF pressure difference (Low)
P244B	DPF pressure difference (High)
P2458	DPF manual regeneration error
P2463	DPF regeneration operation error
P24A2	DPF fuel additive quantity too much
P2633	Fuel pump Magnetic valve2 failure (OPEN/GND short circuit)
P2634	Fuel pump Magnetic valve2 failure (+B short circuit)
P2635	Fuel Pump A" Low Flow/Performance "
U0073	CAN Communication error (Engine)
U1001	CAN communication error.(Mechatronics controller , Diag CAN)
U110A	CAN communication disrupt (Mechatronics controller)
U1122	Communication error (EGR)
U1123	Communication error (VNT)
ML-ME35	Adjustment data are abnormal. Carry out adjustment work again.
ML-ME36	The malfunction of the load cell for the boom (1).
ML-ME37	The malfunction of the load cell for the boom (2).
ML-ME38	The malfunction of the load cell for the jib (1).
ML-ME39	The malfunction of the load cell for the jib (2).
ML-ME44	The malfunction of the boom base angle sensor.
ML-ME45	The malfunction of the boom tip angle sensor.
ML-ME46	The malfunction of the mast angle sensor.

Code	Message
ML-ME47	The malfunction of the jib base angle sensor.
ML-ME48	The malfunction of the jib tip angle sensor.
ML-ME49	Data in the ML flash memory are abnormal.
ML-ME50	ML test mode
ML-ME51	Construction mode data not matched.
ML-ME52	Construction mode option not matched.
ML-ME53	Transmission or ML failure.
ML-ME54	DPF Regeneration control not possible.
ML-ME55	Between ECU-ML transmission abnormal.
ML-ME68	Writing error of operator identification ID and/or password.
ML-ME69	Writing error of WORKING AREA LIMIT values.
ML-ME80	Not use
ML-ME84	Lateral inclination is out of range.
ML-ME85	Longitudinal inclination is out of range.
ML-ME86	MC1 redundancy switch is operating.
ML-ME87	MC2 redundancy switch is operating.
ML-ME89	Time out error of synchronizing check during the MC1 start-up process.
ML-ME90	Time out error of synchronizing check during the MC2 start-up process.
ML-ME92	Error No.1 of ML internal setting values abnormality. (Optional item setting)
ML-ME93	Error No.2 of ML internal setting values abnormality. (Crane data)
ML-ME94	Error No.3 of ML internal setting values abnormality. (Manufacturer adjustment data)
ML-ME95	Error No.4 of ML internal setting values abnormality. (Temporary adjustment data)
ML-ME96	Error No.5 of ML internal setting values abnormality. (Crane operation data)
ML-ME97	Error No.6 of ML internal setting values abnormality. (Data for each case)
ML-ME98	Error No.7 of ML internal setting values abnormality. (Overload record data)
ML-ME99	Error No.8 of ML internal setting values abnormality. (Failure history data)
ML-ME100	Writing error of optional item setting.
ML-ME101	Writing error of crane data.
ML-ME102	Writing error of manufacturer adjustment data.
ML-ME103	Writing error of temporary adjustment data.
ML-ME104	Writing error of crane operation data.
ML-ME105	Writing error of the data of each case.
ML-ME106	Writing error of overload record data.
ML-ME107	Writing error of failure history data.
ML-ME108	Error of the MC crane model number unmatched.
ML-ME109	Error of the MC optional item setting unmatched.
ML-ME110	Communication error between touch panel monitor.
ML-ME111	Time out error of MC1 & MC2 adjustment response.
ML-ME112	CAN communication error with MC1.
ML-ME113	CAN communication error with MC2.
ML-ME114	CAN communication sending error with MC1 & MC2.

[3. LOAD SAFETY DEVICE]

Code	Message
ML-ME115	Error No.9 of ML internal setting values abnormality. (Failure history data of MC1)
ML-ME116	Error No.10 of ML internal setting values abnormality. (Failure history data of MC2)
ML-ME117	Writing error of failure history data for MC1.
ML-ME118	Writing error of failure history data for MC2.
ML-ME119	Error No.11 of ML internal setting values abnormality. (Operator identification ID and/or password)
ML-ME120	Error No.12 of ML internal setting values abnormality. (WORKING AREA LIMIT values)
ML-ME121	Access error to NOR flash memory in ML. Setting values can not be written.
ML-ME122	MC1 & MC2 reset is detected.
ML-ME123	Writing error of system information for MC1 or MC2.
ML-ME124	Writing error of optional item setting for MC1 or MC2.
ML-ME125	Writing error of adjustment data for MC1 or MC2.
ML-ME126	Writing error of crane operation data for MC1 or MC2.
ML-ME127	Writing error of No.2. manufacturer adjustment data.
ML-ME128	Error No.13 of ML internal setting values abnormality. (No.2 manufacturer adjustment data)
MC1-A01	Not use
MC1-A02	Not use
MC1-A03	Fr. drum motor speed adjusting trimmer
MC1-A04	Re. drum motor speed adjusting trimmer
MC1-A05	Jib (third) motor speed adjusting trimmer
MC1-A06	Boom motor speed adjusting trimmer
MC1-A07	Not use A/D
MC1-A08	Hand throttle potentiometer
MC1-A09	Foot throttle potentiometer
MC1-A10	Hydraulic oil temperature sensor
MC1-A11	Tagline trimmer
MC1-A12	Control primary pressure sensor
MC1-A13	Swing pump pressure sensor
MC1-A14	Swing operation pressure sensor (R)
MC1-A15	Swing operation pressure sensor (L)
MC1-A16	Qmax cut pressure sensor
MC1-A17	Power shift pressure sensor
MC1-A18	Power supply voltage watch
MC1-A19	Inclination sensor (X)
MC1-A20	Inclination sensor (Y)
MC1-A21	Fr. drum clutch pressure sensor
MC1-A22	3rd. drum clutch pressure sensor
MC1-A23	Re. drum clutch pressure sensor
MC1-D01	Main pump power control proportional valve
MC1-D02	Boom pump power control proportional valve
MC1-D03	Swing speed control
MC1-D04	Swing reaction proportional valve

Code	Message
MC1-D05	Boom pump control proportional valve
MC1-D06	Fr. electromagnetic detent
MC1-D07	Re. electromagnetic detent
MC1-D08	Main pump control proportional valve 1
MC1-D09	Main pump control proportional valve 2
MC1-D10	Tagline proportional valve
MC1-D11	Left swing proportional valve
MC1-D12	Right swing proportional valve
MC1-C01	Fr. drum clutch CLM
MC1-C02	Fr. drum clutch ESM
MC1-C03	Re. drum clutch CLA
MC1-C04	Re. drum clutch ESA
MC1-C05	3rd. drum clutch CLT
MC1-C06	3rd. drum clutch EST
MC1-C07	Not use
MC1-C08	Swing parking brake
MC1-C09	Adjustment mode
MC1-C10	Hyd. oil heat
MC1-C11	Qmax cut
MC1-C12	Swing flasher
MC1-C13	Not use
MC1-C14	Not use
MC1-C15	Battery relay energizing
MC1-C16	Load safety device bypass switch reset
MC1-C17	Solenoid valve
MC1-C18	E/G warning
MC1-C19	Sub Air conditioner ON
MC1-C20	Swing brake mode select
MC1-C21	Sub battery relay energizing
MC1-C22	Not use
MC1-C23	Tower latch cylinder relay
MC1-C24	Not use
MC1-C25	Not use
MC1-C26	Manual regeneration
MC1-C27	E/G restart
MC1-C28	Control primary pressure cut
MC1-C29	Fr. drum turn detecting grip
MC1-C30	Re. drum turn detection grip
MC1-C31	Safety relay
MC1-C32	E/G stop relay
MC1-C33	Swing voice alarm (not used)

[3. LOAD SAFETY DEVICE]

Code	Message
MC1-C34	Not use
MC1-C35	Not use
MC1-C36	Not use
MC1-H01	Not use
MC1-H02	OVERLOAD AUTO STOP IS BEING RELEASED
MC1-H03	FLASH MEMORY DATA FAILURE
MC1-H04	MC ADJUSTMENT IS IRRELEVANT
MC1-H05	RECEIVING ERROR FROM ML
MC1-H06	RECEIVING ERROR FROM MC2
MC1-H07	Not use
MC1-H08	SYSTEM INFORMATION ABNORMAL (E10-4)
MC1-H09	OPTIONAL ITEM SETTING ABNORMAL 1 (E10-1)
MC1-H10	OPTIONAL ITEM SETTING ABNORMAL 2 (E10-2)
MC1-H11	OPTIONAL ITEM SETTING ABNORMAL 3 (E10-3)
MC1-H12	ADJUSTMENT DATA ABNORMAL (E10-5)
MC1-H13	CRANE OPERATION DATA ABNORMAL (E10-6)
MC1-H14	ERROR OF THE DISTINGUISHING SIGNAL BETWEEN MC1 AND MC2. (E10-7)
MC1-H15	ERROR OF PREVIOUS MC1 OR MC2 START-UP MODE DISCREPANCY. (E10-8)
MC2-A01	Not use A/D
MC2-A02	Not use A/D
MC2-A03	Fr. motor pressure sensor
MC2-A04	Re. motor pressure sensor
MC2-A05	3rd. motor pressure sensor
MC2-A06	Not use A/D
MC2-A07	Fuel level sensor
MC2-A08	Fr. independence/confluence pressure sensor
MC2-A09	Re. independence/confluence pressure sensor
MC2-A10	Not use A/D
MC2-A11	Constant horse power pressure sensor
MC2-A12	Not use A/D
MC2-A13	Not use A/D
MC2-A14	Not use A/D
MC2-A15	Not use A/D
MC2-A16	Boom raise pressure sensor
MC2-A17	Boom lower pressure sensor
MC2-A18	Fr. drum hoisting pressure sensor
MC2-A19	Fr. drum lowering pressure sensor
MC2-A20	Re. drum hoisting pressure sensor
MC2-A21	Re. drum lowering pressure sensor
MC2-A22	3rd. drum hoisting pressure sensor
MC2-A23	3rd. drum lowering pressure sensor

Code	Message
MC2-D01	Boom raising speed control
MC2-D02	Boom lowering speed control
MC2-D03	Fr. drum hoisting speed control
MC2-D04	Fr. drum lowering speed control
MC2-D05	Re. drum hoisting speed control
MC2-D06	Re. drum lowering speed control
MC2-D07	3rd. drum hoisting speed control
MC2-D08	3rd drum lowering speed control
MC2-D09	Constant horse power
MC2-D10	Fr. drum motor control
MC2-D11	Re. drum motor control
MC2-D12	3rd drum motor control
MC2-C01	Not use
MC2-C02	Not use
MC2-C03	Not use
MC2-C04	Not use
MC2-C05	Not use
MC2-C06	Not use
MC2-C07	Not use
MC2-C08	Not use
MC2-C09	Not use
MC2-C10	Not use
MC2-C11	Not use
MC2-C12	Not use
MC2-C13	Not use
MC2-C14	Not use
MC2-C15	Fr. drum motor boost
MC2-C16	Oil cooler motor
MC2-C17	Fr. independence/confluence
MC2-C18	Re. independence/confluence
MC2-C19	Hydraulic pressure load addition
MC2-C20	Not use
MC2-C21	Re. drum motor boost
MC2-C22	3rd. drum motor boost
MC2-C23	Not use
MC2-C24	Not use
MC2-C25	Not use
MC2-C26	Fr. drum operation signal
MC2-C27	Re. drum operation signal
MC2-C28	3rd. drum operation signal
MC2-C29	Fr. drum C/V

[3. LOAD SAFETY DEVICE]

Code	Message
MC2-C30	Re. drum C/V
MC2-C31	Not use
MC2-C32	Not use
MC2-C33	Not use
MC2-C34	Not use
MC2-C35	Not use
MC2-C36	3rd. drum C/V
MC2-H01	Not use
MC2-H02	OVERLOAD AUTO STOP IS BEING RELEASED
MC2-H03	FLASH MEMORY DATA FAILURE
MC2-H04	MC ADJUSTMENT IS IRRELEVANT
MC2-H05	RECEIVING ERROR FROM ML
MC2-H06	RECEIVING ERROR FROM MC1
MC2-H07	Not use
MC2-H08	SYSTEM INFORMATION ABNORMAL (E10-4)
MC2-H09	OPTIONAL ITEM SETTING ABNORMAL 1 (E10-1)
MC2-H10	OPTIONAL ITEM SETTING ABNORMAL 2 (E10-2)
MC2-H11	OPTIONAL ITEM SETTING ABNORMAL 3 (E10-3)
MC2-H12	ADJUSTMENT DATA ABNORMAL (E10-5)
MC2-H13	CRANE OPERATION DATA ABNORMAL (E10-6)
MC2-H14	ERROR OF THE DISTINGUISHING SIGNAL BETWEEN MC1 AND MC2. (E10-7)
MC2-H15	ERROR OF PREVIOUS MC1 OR MC2 START-UP MODE DISCREPANCY. (E10-8)

Note

When the angle detector is replaced, adjustment of the load safety device becomes necessary. Contact KOBELCO for replacement or adjustment.

Normally error is indicated by its code. By pressing the indicated code area, detail can be indicated.

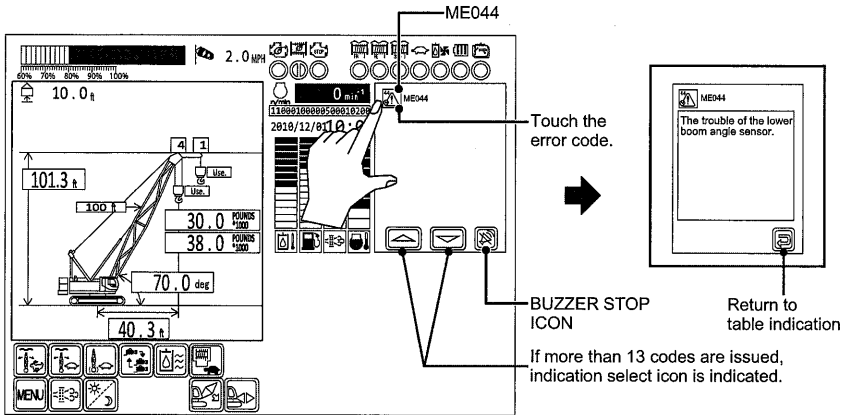

3.13 MESSAGE TABLE

Various messages are indicated based on crane condition.

These are not errors.



The display indicates the code as listed below.
Follows the instruction shown.

Note

The table includes all codes.
There are no some codes which are not displayed based on models.

Code	Message	Condition, Action
W01	ENGINE PREHEAT	The message is displayed when the engine coolant temperature is 0 degrees or less with the key switch turned ON.
W02	PREHEAT COMPLETED	The message is displayed for 5 seconds after the preheat is complete.
W03	CHARGING PROBLEM	The charging circuit is malfunctioned. Consult with your nearest KOBELCO authorize distributor. * It is not fault even this item is momentarily displayed immediately after the engine is started.
W04	PILOT PRESSURE (PRIMARY) ABNORMAL	The control primary pressure is abnormal. Stop the operation at once, and consult with your nearest KOBELCO authorize distributor. * It is not fault even this item is momentarily displayed immediately after the engine is started.
W05	ENGINE OIL PRESSURE	The engine oil pressure is abnormal. Stop the engine at once, and consult with your nearest KOBELCO authorize distributor.
W06	ENGINE WATER LEVEL	The cooling water level in the radiator is insufficient. Refill the radiator with cooling water.
W08	ENGINE COOLANT TEMPERATURE	The coolant temperature is excessively high. Idle the engine to lower temperature, and consult with your nearest KOBELCO authorize distributor.
W09	ENGINE OIL FILTER	The engine oil filter is clogged. Replace the filter.
W10	ENGINE AIR FILTER	The engine air cleaner is clogged. Clean or replace the element.
W11	EMPTY FUEL	The fuel level is insufficient. Refuel.
W12	HYDRAULIC OIL TEMPERATURE	The hydraulic oil temperature is excessively high. Adjust the engine speed to the medium level to lower the oil temperature, and consult with your nearest KOBELCO authorize distributor.

Code	Message	Condition, Action
W13	FRONT WINCH COOLING CIRCUIT OIL TEMPERATURE	The temperature of clutch cooling oil of the front drum is excessively high. Idle the engine at a high speed to lower the oil temperature. If this item frequently appears during normal operations, consult with your nearest KOBELCO authorize distributor. At the same time, inform the KOBELCO service of the details of the operation (lifting load, free fall distance, speed, and duration).
W14	REAR WINCH COOLING CIRCUIT OIL TEMPERATURE	The temperature of clutch cooling oil of the front drum is excessively high. Idle the engine at a high speed to lower the oil temperature. If this item frequently appears during normal operations, consult with your nearest KOBELCO authorize distributor. At the same time, inform the KOBELCO service of the details of the operation (lifting load, free fall distance, speed, and duration).
W15	WINCH FILTER CLOGGED	The winch cooling line filter is clogged. Replace the filter cartridge. This item may appear during cold weather even when the filter is not clogged. If the item disappear during warm-up, the cartridge does not need to be replaced.
W16	FRONT SAFETY ESM SOLENOID VALVE IS ENERGIZED	The front drum clutch emergency system is actuated. The free fall of the front drum cannot be normally performed. Place a load and the hook onto the ground, and turn the key switch to the OFF position. Then, consult your nearest KOBELCO authorize distributor. DO NOT operate the key switch with a load or the hook hung in the air, since it may cause drop of the load or the hook.
W17	REAR SAFETY ESA SOLENOID VALVE IS ENERGIZED	The front drum clutch emergency system is actuated. The free fall of the front drum cannot be normally performed. Place a load and the hook onto the ground, and turn the key switch to the OFF position. Then, consult your nearest KOBELCO authorize distributor. DO NOT operate the key switch with a load or the hook hung in the air, since it may cause drop of the load or the hook.
W18	3RD SAFETY EST SOLENOID VALVE IS ENERGIZED	The front drum clutch emergency system is actuated. The free fall of the front drum cannot be normally performed. Place a load and the hook onto the ground, and turn the key switch to the OFF position. Then, consult your nearest KOBELCO authorize distributor. DO NOT operate the key switch with a load or the hook hung in the air, since it may cause drop of the load or the hook.
W21	ML BYPASS SWITCH IS OPERATING	The moment limiter redundancy switch is actuated. The moment limiter is malfunctioned, and automatic stop operation due to overload and the overhoisted hook block is impossible. Immediately stop the operation, or return extremely carefully, and consult with your nearest KOBELCO authorize distributor.
W22	DPF OPTION SETTING ABNORMAL	Option setting dose not match with engine spec. Contact KOBELCO service shop.
W23	FRONT DRUM ROTATION SENSOR ADJUSTMENT	Front drum rotation sensor is not functioning properly. Adjust sensor position. If not corrected even after adjustment, contact KOBELCO service shop.

Code	Message	Condition, Action
W24	REAR DRUM ROTATION SENSOR ADJUSTMENT	Rear drum rotation sensor is not functioning properly. Adjust sensor position. If not corrected even after adjustment, contact KOBELCO service shop.
W31	FRONT DRUM NEGA BRAKE ABNORMAL	Front drum nega brake function may be abnormal. Contact KOBELCO service shop.
W32	REAR DRUM NEGA BRAKE ABNORMAL	Rear drum nega brake function may be abnormal. Contact KOBELCO service shop.
W33	3RD. DRUM NEGA BRAKE ABNORMAL	3rd. drum nega brake function may be abnormal. Contact KOBELCO service shop.
W35	BATTERY RELAY ABNORMAL	Battery relay contact may be adhered. Inspect battery relay. Replace if the deposited at the contact point of the relay.
W36	PROPEL LEVER INTERLOCKED	Propel lever is kept ON. Pilot pressure is cut. Return propel lever back to neutral.
W37	FRONT DRUM LEVER INTERLOCKED	Front drum is stopped since front drum lever is kept ON. Return front drum lever back to neutral.
W38	REAR DRUM LEVER INTERLOCKED	Rear drum is stopped since rear drum lever is kept ON. Return rear drum lever back to neutral.
W39	3RD. DRUM LEVER INTERLOCKED	3rd. drum is stopped since 3rd. drum lever is kept ON. Return 3rd. drum lever back to neutral.
W40	BOOM DRUM LEVER INTERLOCKED	Boom drum is stopped since boom drum lever is kept ON. Return boom drum lever back to neutral.
W41	REMOTE CONTROLLER CONNECTED	Remote control is connected. Disconnect remote control for crane work.
W42	MC1, 2 CHARGE SIGNAL ABNORMAL	Charge signal differs on each MC. Contact KOBELCO service shop.
W44	MC1, 2 FUNCTION LOCK SIGNAL ABNORMAL	Function lock signal differs on each MC. Contact KOBELCO service shop.
W45	MC1, 2 INCHING SPEED SELECT SIGNAL ABNORMAL	Inching speed select signal differs on each MC. Contact KOBELCO service shop.
W46	Qmax CUT SOL OUTPUT OFF ABNORMAL	Qmax cut solenoid relay contact is adhered at energize side. The engine revolution will be restricted not to raising the maximum revolution. Contact KOBELCO service shop.
W47	Qmax CUT SOL OUTPUT ON ABNORMAL	Qmax cut solenoid relay is not functioned. The engine revolution will be restricted not to raising the maximum revolution. Contact KOBELCO service shop.
W48	ACTUAL ROTATION IS HIGHER THAN NO LOAD ROTATION	Either front or rear winch motor is running over speed or engine speed is over. Contact KOBELCO service shop.
W49	HIGH LOAD TORQUE	The engine reached to the maximum torque situation, Avoid abrupt operation. Be sure, there is a possibility of stopping the engine due to the abrupt load is taken. Released indication by decrease the winch speed and/or the engine load.

Code	Message	Condition, Action
W50	JOY STICK ABNORMAL	Joy stick accel switch exceeds neutral range. Return it to neutral position. If error continues even at neutral position, contact KOBELCO service shop.
W51	BACK UP FUSE BLOWN OUT	Back up fuse (F-4) of each controller is blown off. Replace with new one.
W52	HOOK OVERHOIST LS	MC2 detects hook overhoist. Check ML or hook overhoist signal and then contact KOBELCO service shop.
W53	BOOM OVERHOIST LS	MC2 detects boom overhoist. Check ML or boom overhoist signal and then contact KOBELCO service shop.
W54	JIB OVERHOIST LS	MC2 detects jib overhoist. Check ML or jib overhoist signal and then contact KOBELCO service shop.
W55	BOOM BACKSTOP No.1 LS	MC2 detects boom backstop No.1 overhoist. Check ML or boom backstop No.1 overhoist signal and then contact KOBELCO service shop.
W56	BOOM BACKSTOP No.2 LS	MC2 detects boom backstop No.2 overhoist. Check ML or boom backstop No.2 overhoist signal and then contact KOBELCO service shop.
ML-ME01	Out of working angle.	Out of capacity set range.
ML-ME02	Hook over hoist release switch is operating.	The hook overhoist automatic stop release switch is actuated.
ML-ME03	Boom/Jib over hoist release switch is operating.	The boom overhoist automatic stop release switch is actuated.
ML-ME04	Overload release switch is operating.	Overload status is canceled.
ML-ME05	Over load condition.	The loading ratio exceeds the specified level. Lower the load to the ground or raise the boom,jib.
ML-ME06	Head wind is strong.	The guy line support force becomes lower than the specified level.
ML-ME07	Boom is lowered too much.	The boom is out of the maximum working radius area. Raise the boom.
ML-ME08	Boom is raised too much.	The boom is out of the minimum working radius area. Lower the boom
ML-ME09	Jib is lowered too much.	The jib is out of maximum working radius area. Raise the jib
ML-ME10	Jib is raised too much.	The jib is out of minimum working radius area. Lower the jib
ML-ME13	Jib is lowered too much.	The jib is out of maximum working radius area. Raise the jib
ML-ME14	Jib is raised too much.	The jib is out of minimum working radius area. Lower the jib
ML-ME15	Mast is raised too much.	The mast is out of minimum working radius area. Lower the mast

[3. LOAD SAFETY DEVICE]

Code	Message	Condition, Action
ML-ME16	Mast is lowered too much.	The mast is out of maximum working radius area. Raise the mast.
ML-ME17	Hook over hoist.	The hook exceed the overhoist limit position. Lower the hook.
ML-ME18	Hook over hoist.	The hook exceed the overhoist limit position. Lower the hook.
ML-ME19	Mast cylinder limit switch has not been turned on.	The support is not out of stowed position. for mast. Extend the mast support.
ML-ME20	Detecting limit switch for high gantry position has not been turned on.	The gantry is not raised for mast raising. Raise the gantry.
ML-ME21	Boom over hoist.	The boom overhoist limit switch is actuted. Lower the boom.
ML-ME22	Jib over hoist.	The jib overhoist limit switch is actuated. Lower the jib
ML-ME24	Overload precautions.	Loading ratio is 90% or more, and lower than the specified level.
ML-ME25	Reached the load limitation value of WORKING AREA LIMIT function.	Lifting load exceeds the lifting load limit value set by operator. Lower the load or raise the jib or boom.
ML-ME26	Reached 90% of the load limitation value of WORKING AREA LIMIT function.	Lifting load exceeds 90% of the lifting load limit value set by operator.
ML-ME27	Boom angle reached upper limitation value of WORKING AREA LIMIT function.	The boom reaches the boom angle upper limit point (stop point) set by operator. Lower the boom.
ML-ME28	Boom angle reached lower limitation value of WORKING AREA LIMIT function.	The boom reaches the boom angle lower limit point (stop point) set by operator. Raise the boom.
ML-ME29	Jib angle reached upper limitation value of WORKING AREA LIMIT function.	The jib reaches the jib angle upper limit point (stop point) set by operator. Lower the jib.
ML-ME30	Jib angle reached lower limitation value of WORKING AREA LIMIT function.	The jib reaches the jib angle lower limit point (stop point) set by operator. Raise the jib.
ML-ME31	Working radius reached limitation value of WORKING AREA LIMIT function.	The boom reaches the working radius limit point (stop point) set by operator. Raise the boom or jib.
ML-ME32	Boom point elevation reached limitation value of WORKING AREA LIMIT function.	The boom reaches the boom height limit point (stop point) set by operator. Lower the boom.
ML-ME33	Jib point elevation reached limitation value of WORKING AREA LIMIT function.	Operator set height limit is reached. Lower the jib.
ML-ME34	Crane configuration setting is wrong.	The attachment set data is abnormal. Re-set the attachment.
ML-ME56	Inspection mode for overload condition.	Load safety device check mode (See P.3-70)

Code	Message	Condition, Action
ML-ME60	Boom over hoist.	The boom overhoist No.2 limit switch is actuated. Lower the boom.
ML-ME61	Jib winch wire rope is tightened a little more than normal.	The tension of the hoist wire rope exceeds the forecast alarm value, during erecting the tower. Loosen the jib hoist wire rope.
ML-ME62	Jib winch wire rope is abnormally tightened.	The tension of the hoist wire rope exceeds the alarm value, during erecting the tower. Loosen the jib hoist wire rope.
ML-ME63	ML crane configuration does not correspond to the counter weight detecting signal.	The input signal from the counterweight detector does not match the data. Check the counterweight detector or check for proper counterweight selecting in the attachment setting.
ML-ME64	ML crane configuration does not correspond to the carbody-weight detecting signal.	The input signal from the carbody-weight detector does not match the data. Check the counterweight detector or check for proper counterweight selecting in the attachment setting.
ML-ME66	Danger!! The jib tip touches at the ground.	The jib connecting pin is not pulled out at lowering of maximum tower length. Pull out the pin. (Only 7200G)
ML-ME81	Front winch over pay out	The front drum over pay out preventive device is actuated. Operate the front drum toward wind up direction.
ML-ME82	Rear winch over pay out	The rear drum over pay out preventive device is actuated. Operate the rear drum toward wind up direction.
ML-ME83	Third winch over pay out	The third drum over pay out preventive device is actuated. Operate the third drum toward wind up direction.

3.14 CHECKING PROCEDURE OF LOAD SAFETY DEVICE

Check the following point of the load safety device once a year.

1. Check of work radius indication
 - (1) Indicate the work radius in the certain point within the work area in lowering motion of boom.
 - (2) Measure the actual work radius with measuring tape and check if it matches with the work radius indication value.

2. Check of actual load indication
 - (1) Lift a load weight which is exactly known in advance.
 - (2) Check if the load (lifting load + hook weight + sling wire weight) matches exactly with the load indication value.

If indication value and actually measured value differ significantly, contact KOBELCO service shop.

4. ASSEMBLY/DISASSEMBLY OF MAIN MACHINERY

4.1	SWING AND PROPEL STABILITY	4-1
4.2	ASSEMBLY OF MAIN MACHINERY	4-3
4.2.1	UNLOADING MAIN MACHINERY FROM TRAILER	4-7
4.2.2	CRAWLER INSTALLATION	4-24
4.2.3	CAB STEP EXTENSION.....	4-39
4.2.4	CARBODY WEIGHT INSTALLATION.....	4-40
4.2.5	ASSEMBLING THE COUNTERWEIGHTS (USING SELF REMOVAL DEVICE)	4-46
4.2.6	REMOVING THE HOOK BLOCK FROM THE BOOM BASE	4-49
4.2.7	SETTING THE COUNTERWEIGHT LINK.....	4-50
4.2.8	INSTALLATION OF COUNTERWEIGHTS TO MACHINE (USING SELF REMOVAL DEVICE)	4-51
4.3	DISASSEMBLY OF MAIN MACHINERY	4-61
4.3.1	REMOVE THE COUNTERWEIGHTS FROM THE MACHINE (USING SELF REMOVAL DEVICE)	4-63
4.3.2	INSTALLATION OF THE HOOK BLOCK TO THE BOOM BASE	4-69
4.3.3	DISASSEMBLY OF THE COUNTERWEIGHT (USING SELF REMOVAL DEVICE)	4-70
4.3.4	CARBODY WEIGHT REMOVAL	4-74
4.3.5	CRAWLER REMOVAL.....	4-78
4.3.6	MAIN MACHINERY LOADING ONTO TRAILER.....	4-93
4.3.7	STOWING CAB STEP.....	4-107
4.4	TRANSPORTATION.....	4-108
4.4.1	CAUTION WHEN TRANSPORTING THE BASE MACHINE	4-109
4.5	LIFTING OF WHOLE MAIN MACHINERY	4-110
4.5.1	UPPER STRUCTURE (WITH CARBODY) LIFTING PROCEDURES	4-111
4.5.2	LOADING/UNLOADING THE MACHINE FROM/ONTO A TRAILER	4-112
4.5.3	INSTALLATION OF CRAWLER.....	4-113
4.5.4	INSTALLATION OF GANTRY TO SWING FRAME.....	4-113
4.6	ASSEMBLY OF BOOM BASE.....	4-116
4.6.1	BOOM BASE INSTALLATION.....	4-117
4.6.2	BACKSTOP INSTALLATION	4-119
4.6.3	UPPER SPREADER INSTALLATION.....	4-120
4.6.4	REEVING BOOM HOIST WIRE ROPE.....	4-121
4.6.5	INSTALLATION OF BOOM HOIST WIRE ROPE TO THE DRUM.....	4-123
4.6.6	REEVING HOOK HOIST WIRE ROPE	4-124
4.7	DISASSEMBLY OF BOOM BASE.....	4-125
4.7.1	WINDING UP OF BOOM HOIST ROPE	4-125
4.7.2	UPPER SPREADER REMOVAL.....	4-127
4.7.3	BACKSTOP REMOVAL.....	4-128

4.7.4	REMOVAL OF BOOM BASE.....	4-130
4.8	EXTENDING/RETRACTING THE CRAWLERS.....	4-132
4.8.1	EXTENDING THE CRAWLER.....	4-132
4.8.2	RETRACTING THE CRAWLER.....	4-141

4. ASSEMBLY/DISASSEMBLY OF MAIN MACHINERY

4.1 SWING AND PROPEL STABILITY

1. Without carbody weight

Attachment	Counterweight : t (lbs)	All-round swing			Travel on slope	
		Crawler extend	Crawler retract	When jacked up without crawler	Forward	Backward
Without attachment (Base machine only)	0 (Without)	○	○	○	○	○
	11.6 (25,573) (No.1)	○	△ (No abrupt lever control)	×	○	○
	23.1 (50,925) (No.1 to No.2)	○	×	×	×	○
	34.6 (76,277) (No.1 to No.3)	×	×	×	×	×
With basic boom (Boom angle : 30 degrees or less)	0 (Without)	○	○	○	○	○
	11.6 (25,573) (No.1)	○	○	×	○	○
	23.1 (50,925) (No.1 to No.2)	○	×	×	△ (Slope 8 degrees or less)	○
	34.6 (76,277) (No.1 to No.3)	△ (No abrupt lever control)	×	×	×	△ (No abrupt lever control)

○ : Allowed
 △ : With restriction
 × : Not allowed

- (1) The table above shows the values for operation on firm ground.
 On a weak ground, operate with care after improving the ground.
- (2) Swinging on a trailer is prohibited.
- (3) Maximum slope angle is 21.8 degrees (40%).
 This may become lower depending on condition (ground, crane configuration).
- (4) Travelling "forward" means that the counterweight is at the lower side of the slope, and "backward" is the counterweight is at the higher side of the slope.

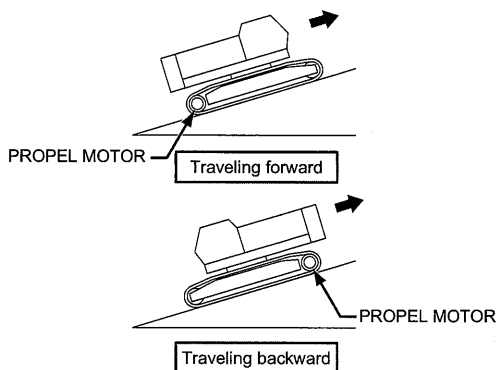

4

2. With carbody weight

Attachment	Counterweight : t (lbs)	All-round swing			Travel on slope	
		Crawler extend	Crawler retract	When jacked up without crawler	Forward	Backward
Without attachment (Base machine only)	0 (Without)	○	○	○	○	○
	11.6 (25,573) (No.1)	○	○	×	○	○
	23.1 (50,925) (No.1 to No.2)	○	×	×	△ (Slope 5 degrees or less)	○
	34.6 (76,277) (No.1 to No.3)	△ (No abrupt lever control)	×	×	×	△ (No abrupt lever control)
With basic boom (Boom angle : 30 degrees or less)	0 (Without)	○	○	○	○	○
	11.6 (25,573) (No.1)	○	○	△ (No abrupt lever control)	○	○
	23.1 (50,925) (No.1 to No.2)	○	×	×	△ (Slope 12 degrees or less)	○
	34.6 (76,277) (No.1 to No.3)	○	×	×	×	○

○ : Allowed
 △ : With restriction
 × : Not allowed

- (1) The table above shows the values for operation on firm ground.
 On a weak ground, operate with care after improving the ground.
- (2) Swinging on a trailer is prohibited.
- (3) Maximum slope angle is 21.8 degrees (40%).
 This may become lower depending on condition (ground, crane configuration).
- (4) Travelling "forward" means that the counterweight is at the lower side of the slope, and "backward" is the counterweight is at the higher side of the slope.

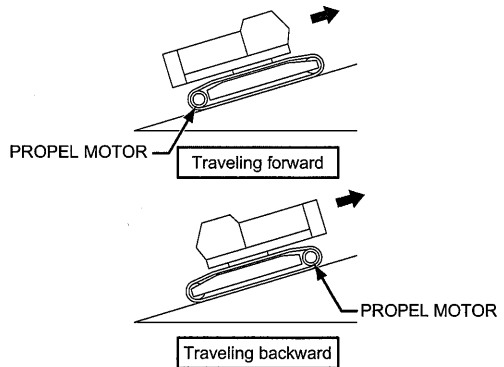

4.2 ASSEMBLY OF MAIN MACHINERY

This article explains assembly of the main machinery for unloading, changing to work configuration.

WARNING

Any work on the main machinery would be dangerous if proper procedure is not taken.

Hold a pre-work meeting to go over the procedure to prevent accident and proceed with the work safely.

Failure to observe these precautions may result in a serious injury or loss of life.

WARNING

Do not insert finger or hand into a pin hole when aligning, inserting or removing pin.

Failure to observe this precaution may result in a serious injury or loss of life.

WARNING

The ground where main machinery is placed during assembly or disassembly may receive large load.

Place steel plates on the ground.

Use proper rated assist crane, slings, shackles and other equipment.

Failure to observe these precautions may result in a serious accident.

1. Check point prior to work

- A qualified supervisor who is competent in the procedures.
- Hold a pre-work meeting for safety.
Review potential hazards and hazardous locations in the course of work.
- Make every worker aware of work contents, procedure and signal.
- Inspect assist crane and other equipment for their condition.

2. Securing place

- Select a firm and level space enough for the task. Place steel plates or crane mats.
- Assign areas for the assist crane, parts storage and trailer access.
- The ground shall be drained unless the place is in marshes or wetland.

3. Preparation before work

- Secure the setting place of assist crane and prepare the required lifting gears, protective materials and tools.
- Secure required number of workers for the work.
(Crane operators, assistant operators, slinging workers and signal persons)
- Take appropriate action to keep unrelated person off the work area other than workers during work.

4. Cautions during assembly work

- During assembly work, install the waterproof cap on the cable end of the hook over-hoist preventing device.
During crane work, remove the waterproof cap and wire the overhoist cable properly.
- Refer to the article 8 "DIMENSION, WEIGHT OF EACH COMPONENT" for weight, dimension during assembly.
- The operator has to be informed if any person moved to out of sight from the operator or at hazardous location when equipment or machine part moves.

5. Open exhaust cover

- An exhaust cover is installed to keep exhaust gas away from person on the platform when engine is running.

The exhaust cover must be kept open when engine is running, and in the stowed position during transportation.

OPERATION

- (1) Remove the lock pins and rotate the exhaust cover toward outer side before starting the engine.
- (2) Secure the exhaust cover with the lock pins.
- (3) Reverse the order to put the cover back for transport.

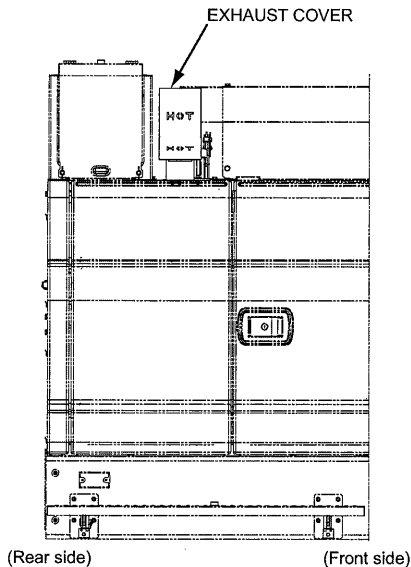

4

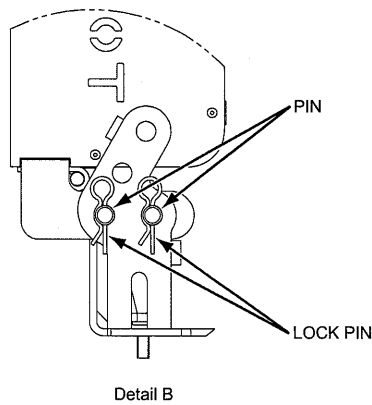
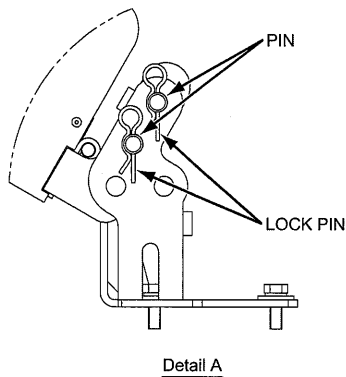
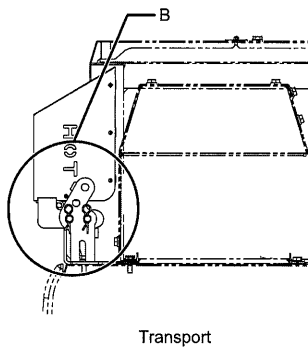
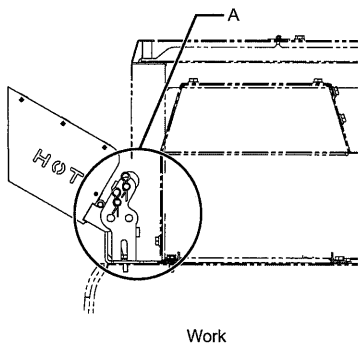

Note

If crane is operated with the exhaust cover closed, the engine output may be reduced.
Ensure to work with the exhaust cover open.

CAUTION

The exhaust cover may be hot.

CAUTION

Watch your head when walking/moving on the platform.

WIDTH OF THE MACHINE

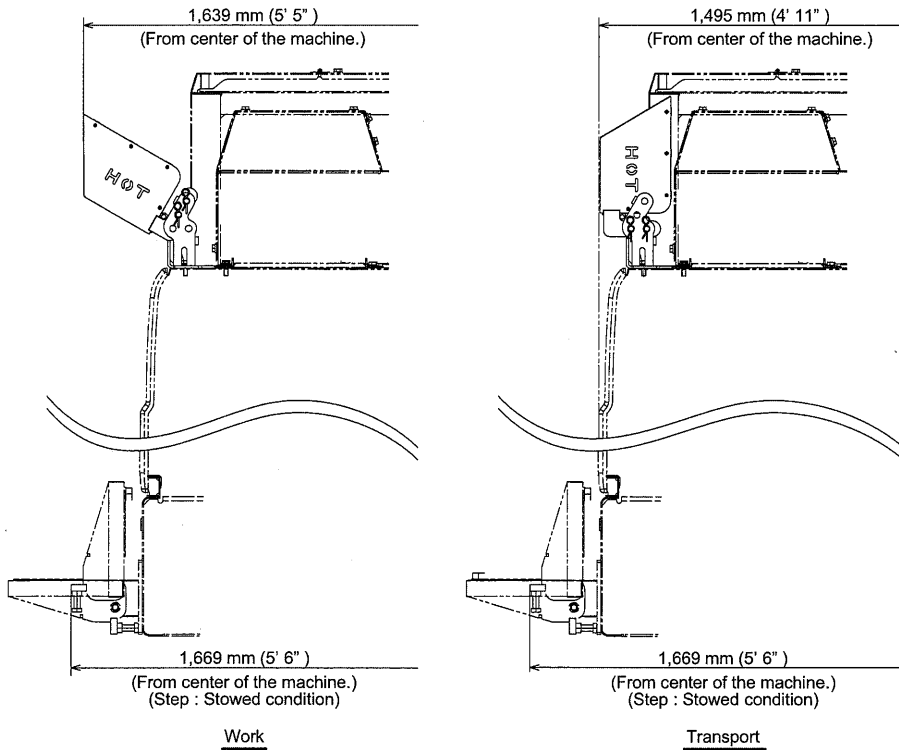

4.2.1 UNLOADING MAIN MACHINERY FROM TRAILER

1. General

This article explains unloading or loading of the main machinery from the trailer using the transliifter.

Although the main machinery can be transported with boom base attached, remove the boom base if the transport weight must be reduced.

Check the following points before starting the work.

(1) Place

Ground should be firm and level.

If needed, place steel plates.

(2) Meeting for work procedure and safety

Prior to work, meeting must be held for work procedure and safety with all related personnel and confirmation of each personnel's roles and responsibilities.

(3) Pre-work inspection

Conduct the pre-work inspection.

DANGER

Do not raise the boom to higher than 10 degrees angle when loading into trailer.

Main machinery may overturn backward.

Failure to observe this precaution may result in a serious injury or loss of life.

2. Translifter

Translifter is an auxiliary device for removing or installing the crawlers or to use during loading or unloading the crane main machinery from the trailer.

Use the translifter in the wide, level and firm ground taking the trailer access direction, assist crane for crawler lifting into account.

The translifter vertical cylinder force may reach to max. 35 t (77,160 lbs) per piece.

Ensure to check the ground condition.

For safety, place the steel plates under the floats.

Float dimension : 40 cm (16 in.) × 40 cm (16 in.)

Float area : 1,550 cm²

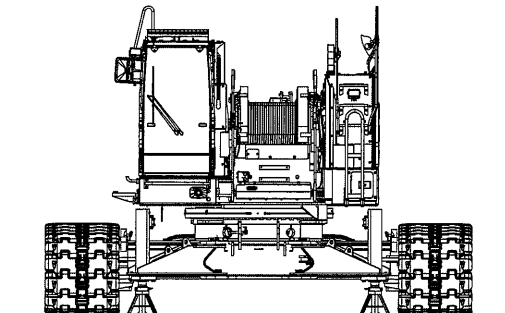

⚠ DANGER

When the translifter is to be used, set the main machinery on level and firm ground.

When the translifter is used on inclined or soft ground, a serious accident such as overturning of the main machinery or damaging the translifter may be caused.

Failure to observe this precaution may result in a serious accident.

⚠ DANGER

When the translifter is to be used, ensure to remove all the counterweights and the carbody weight.

If the translifters are used with these weights installed, a serious accident such as overturning of the main machinery or damaging the translifter may be caused.

Failure to observe this precaution may result in a serious accident.



To prevent overturning of the main machinery, ensure to engage the swing brake and swing lock when the translifter is handled.

Failure to observe this precaution may result in a serious accident.



Do not put finger or hand into pin hole.

Failure to observe this precaution may result in a serious injury.

(1) Construction of translifter

Translifter is composed of the following units and parts.

Four vertical cylinders to push up and hold the main machinery	(a) (b) (c) (d)
Remote control switch box	(e)
Level gauge	(f)
Vertical cylinder hose 8 pieces	(g)

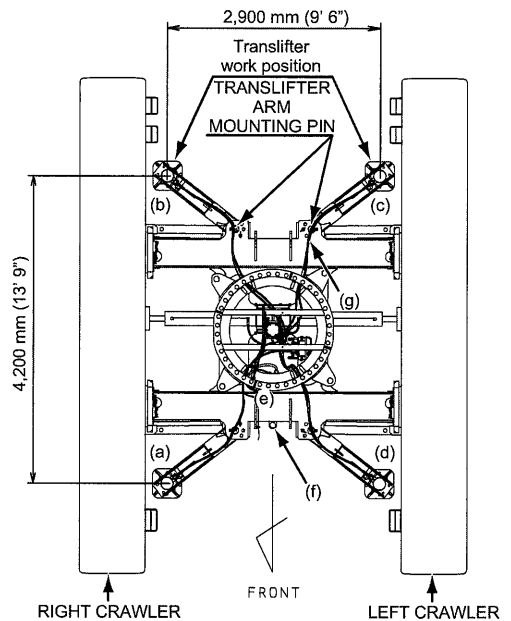

(2) Handling the remote control switch box

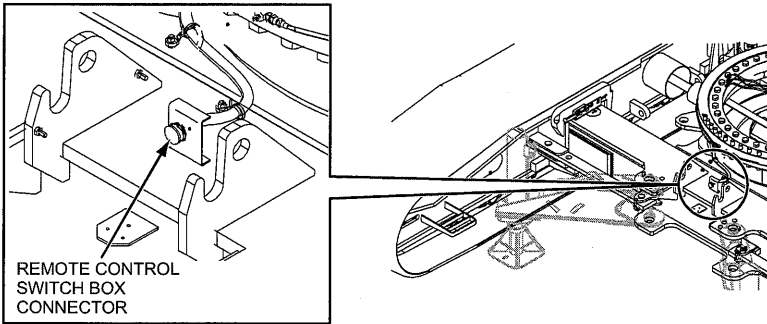

REMOTE CONTROL SWITCH BOX

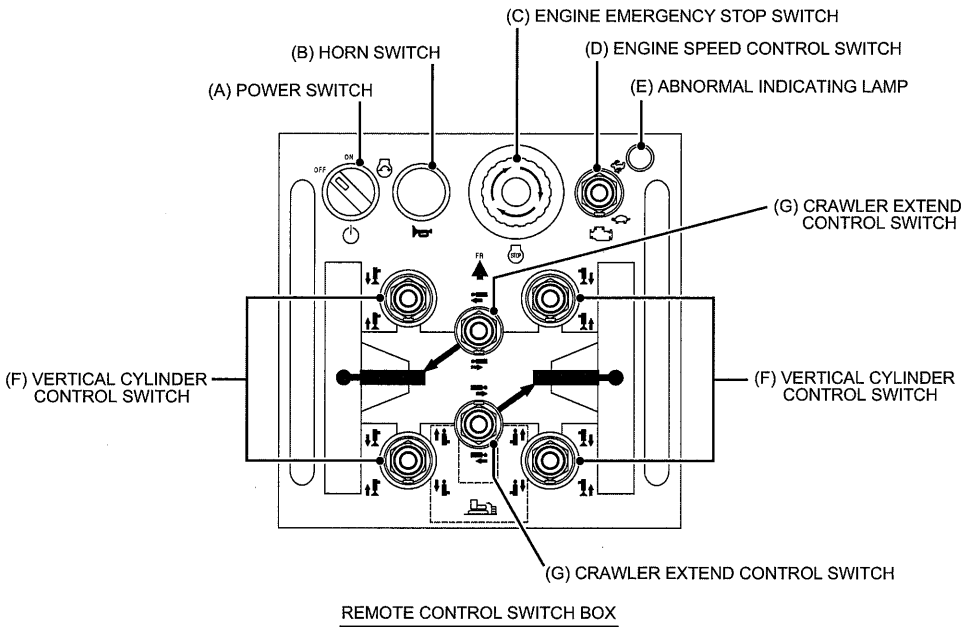

(A) Power switch

OFF	Power off. Turning to this position stops the engine.
ON	Power is supplied to crane portion.
	Engine starts. When released, the switch automatically return to ON position.

(B) Horn switch

Press this switch to sound the horn.

4



(C) Engine emergency stop switch

Press this switch to stop the engine in emergency.

The switch stays at depressed position.

To reset, turn the switch to right or pull.

(D) Engine speed control switch

	Increase the engine speed.
	Decrease the engine speed.



(E) Abnormal indicating lamp

This lamp turns ON when the engine abnormality occurs.

When this lamp is ON, check the detail of abnormality by the cab monitor and take appropriate action.



(F) Vertical cylinder control switch

This switch is used to control the transliifter.

	Cylinder extends (jack up)
	Cylinder retracts (jack down)

(G) Crawler extend control switch

This switch is used to control the crawler ext/ret cylinder.

	Crawler extends
	Crawler retracts

- (3) Apply grease on the translifter mounting pin.
(8 locations)

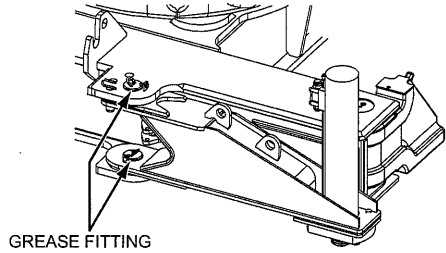

- 3. Unloading of main machinery from the trailer
 - (1) After checking the ground condition, park the trailer on the leveled place.
 - (2) Remove the wire rope and chain from the axle.

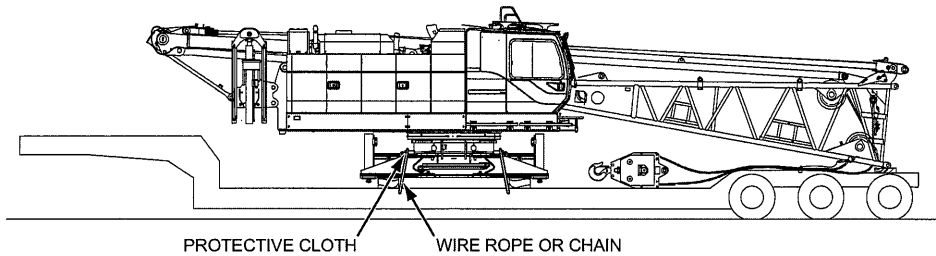
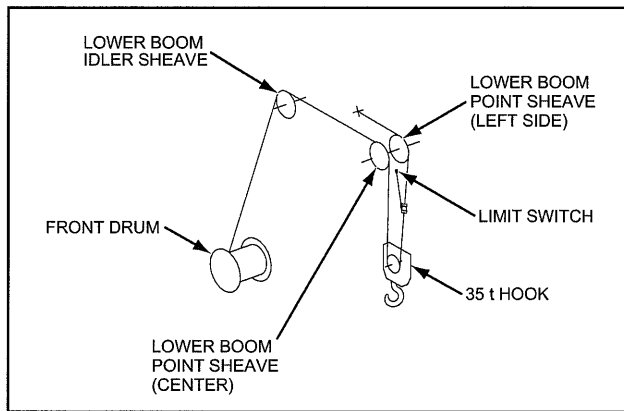

- (3) Pull out the pin (a) securing the translifter at (d).
Align the translifter fixing hole with (e) and secure with pin (a).

⚠ DANGER

When the translifter is to be used, set the main machinery on level and firm ground.

When the translifter is used on inclined or soft ground, a serious accident such as overturning of the main machinery or damaging the translifter may be caused.

Failure to observe this precaution may result in a serious accident.

⚠ DANGER

When the translifter is to be used, ensure to remove all the counterweights and the carbody weight.

If the translifters are used with these weights installed, a serious accident such as overturning of the main machinery or damaging the translifter may be caused.

Failure to observe this precaution may result in a serious accident.

⚠ WARNING

To prevent overturning of the main machinery, ensure to engage the swing brake and swing lock when the translifter is handled.

Failure to observe this precaution may result in a serious accident.

⚠ WARNING

Do not put finger or hand into pin hole.

Failure to observe this precaution may result in a serious injury.

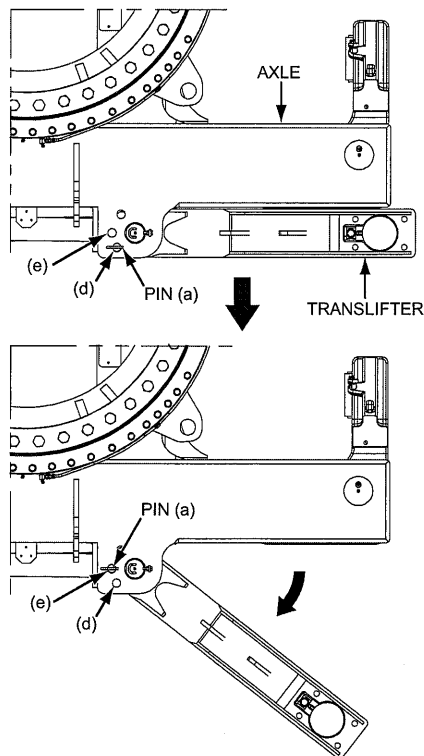

⚠ DANGER

Crane work prohibited if translifter is at “transport with crawler position”.

If the machine swings at this position, the machine would overturn to rear side.

Ensure to set the machine to “translifter work position”.

Failure to observe this precaution may result in a serious injury or loss of life.

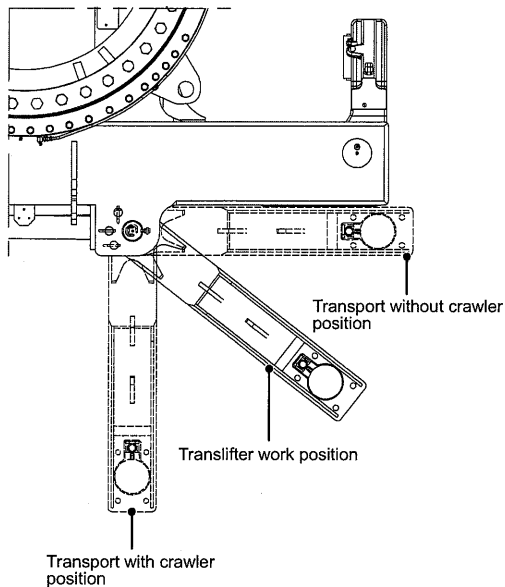

- (4) Install the float to the vertical cylinder and fix with the pin (c).
Place steel plates under the floats for safety.

⚠ CAUTION

The float weight approx. 32 kg (72 lbs).
Handle the float with two persons to prevent injuries.

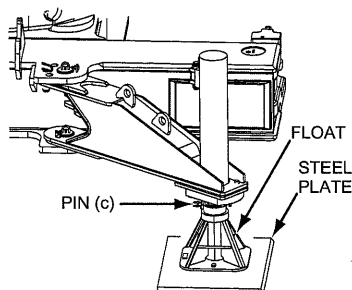

- (5) Ensure that the hydraulic hoses are connected to the vertical cylinders.
(Hydraulic hose 4 locations total 8 pieces)

CAUTION

Check to see that the coupler does not come apart when pulled.

- (6) Connect the remote controller and start the engine and set the speed to low.
(Approx. 800 min⁻¹ [800 rpm])
- (7) Engage the swing brake and keep the swing lock pin inserted and set the function lock lever to "LOCK" position (Upper side).
- (8) Extend the vertical cylinder by operating the vertical cylinder remote control switch box until a slight gap can be seen between the bottom of the main machinery and the loading deck of the trailer.

When operating the vertical cylinder, keep the main machinery level by observing at the level gauge.

Ensure to place all four floats surely on the ground.

WARNING

Check if there is any abnormality on the ground condition of the float contacting area to prevent overturning of the machine.

Failure to observe this precaution may result in a serious accident.

WARNING

To prevent overturn of the main machinery, ensure to engage the swing brake and lock when handling the translifter.

Failure to observe this precaution may result in a serious accident.

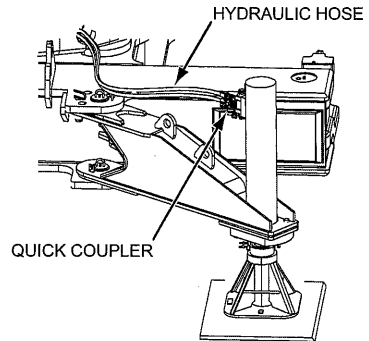

4. Setting of LMI

When removing or attaching the installing carbody weight, set up the LMI as the following.

Note

Unless carrying out the following steps, the machine maybe stopped by the auto-stop function and becomes impossible to work.

- (1) Press  icon on the main screen to display the menu.

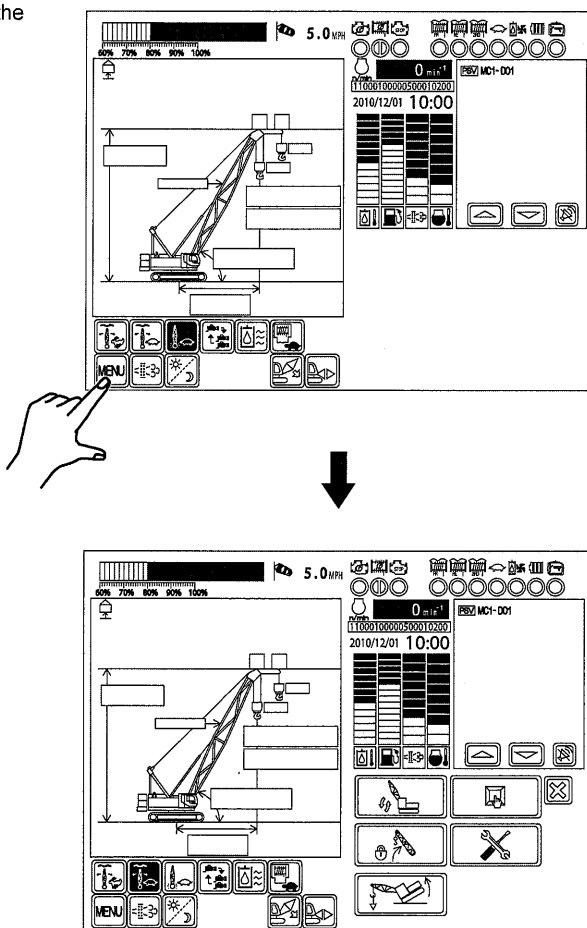

(2) On the selected screen, press  icon.

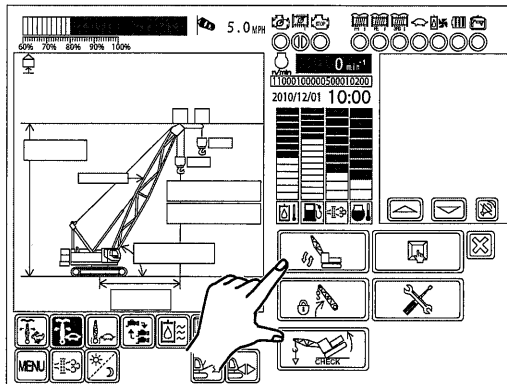

4

(3) Crane attachment select screen is displayed.
Select 10 (Self removal mode).

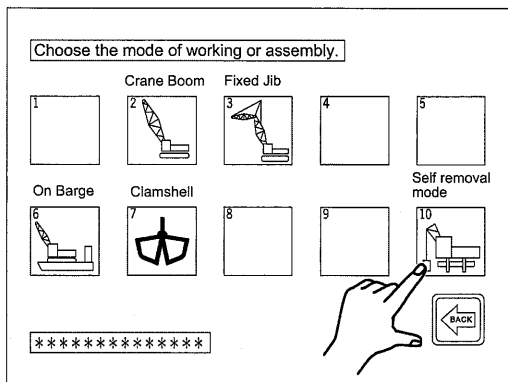

(4) Data is being loaded.

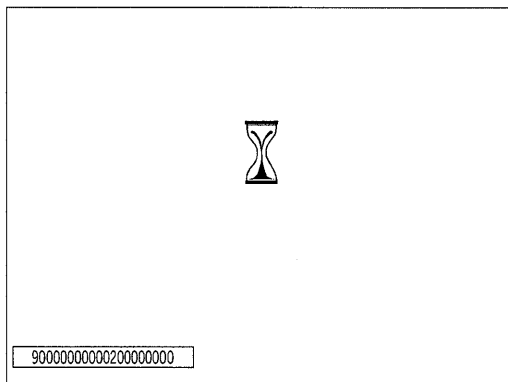

(5) After data is loaded, the result of selection is displayed.

Check if the selected items are correct.

If correct, press .

The screen returns to the main screen.

If not correct, press  to restart the input.

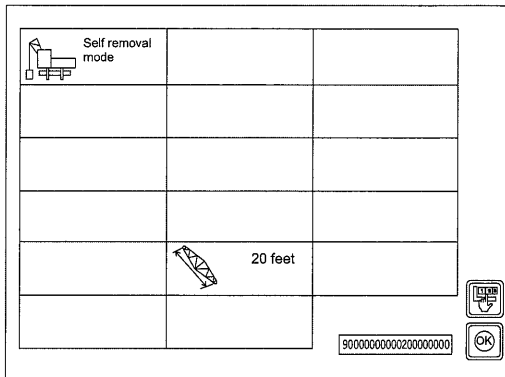

Note

In case the selection is limited to only one choice, some steps may be skipped and only the result is displayed.

5. Raising gantry

! DANGER

Do not allow any person to enter under or inside of the gantry or boom.

Do not touch the wire rope or sheave during winding up the boom hoist wire rope.

Failure to observe these precautions may result in serious injuries or loss of life.

! CAUTION

Ensure to perform the gantry raising work with the boom placed on the ground.

Take extra care on slack or tension of the boom hoist wire rope.

Raise the gantry from the transport position to work position.

- (1) Pull out the pin (w) fixing the travel kit link on both right and left side and release the links from the swing frame.
(Pin [w] is fixed with the spring pins.)
- (2) Start the engine and set the speed to approx. $1,000 \text{ min}^{-1}$ (1,000 rpm).

CAUTION

Before starting the engine, check the surrounding and sound the horn.

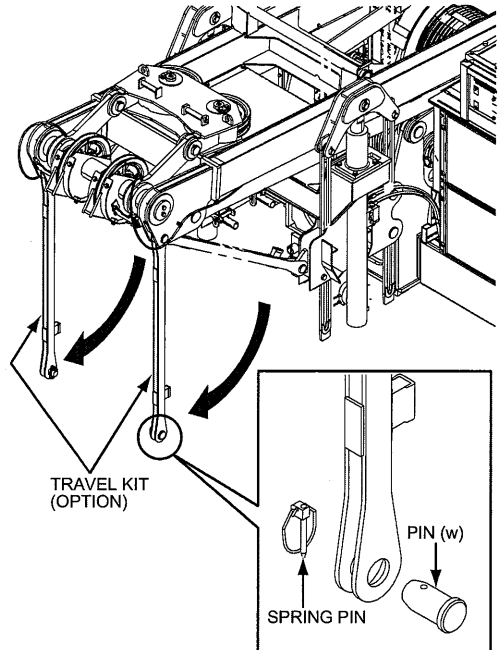

4

- (3) By turning the gantry control switch to "UP" side (outward), raise the gantry with the cylinders.

CAUTION

Before starting the gantry control switch, ensure that there is no person under or near the gantry and sound the horn.

During work, do not operate the gantry control switch if the boom hoist wire rope is tensioned.

WARNING

Do not insert finger or hand into a pin hole when aligning, inserting or removing pin.

Failure to observe this precaution may result in a serious injury or loss of life.

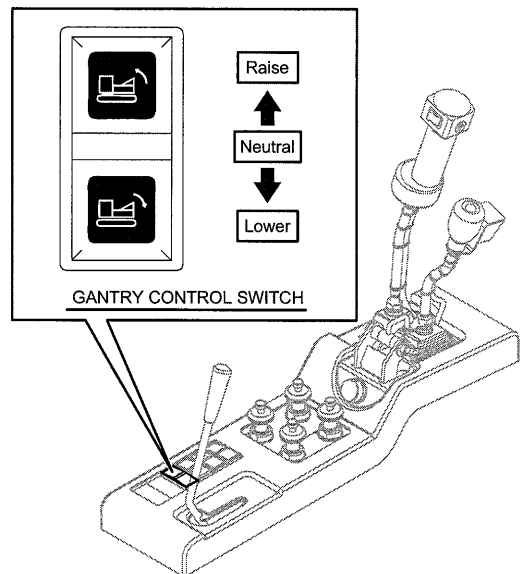

- (4) When the gantry reaches to the "WORK" position, secure travel kit link with stopper by inserting the pin (w) into the link on both right and left side.

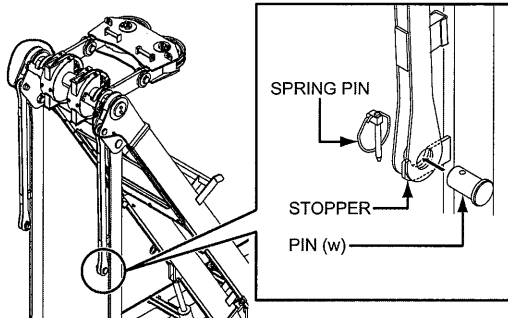

CAUTION

Never raise the gantry by winding the boom hoist wire rope or using an assist crane.
The gantry cylinder maybe damaged.
Use the gantry cylinders.

- (5) Insert the pin (y) into the gantry on both sides and secure them with the spring pins.

WARNING

Do not insert finger or hand into a pin hole when aligning, inserting or removing pin.
Failure to observe this precaution may result in a serious injury or loss of life.

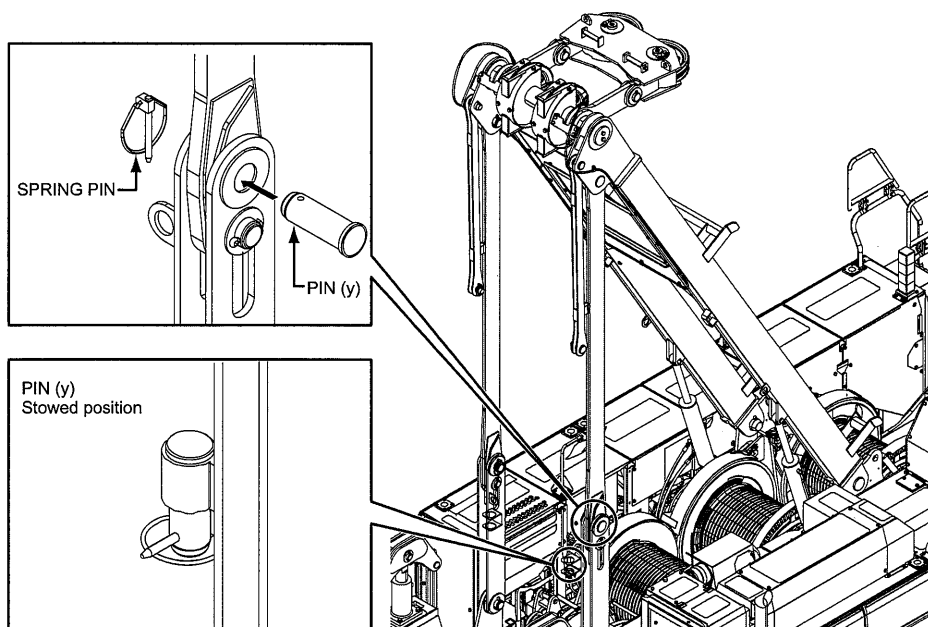

- (6) Wind up the wire rope slowly until the slack is taken up.

In this case, wind up the wire rope to the drum neatly by applying tension on the rope to avoid rough spooling.

⚠ WARNING

Place a signal person to prevent accident from moving machinery or running ropes.

Failure to observe this precaution may result in a serious accident or injury.

6. Rise the boom base to approx. 50 degrees and engage the drum lock.

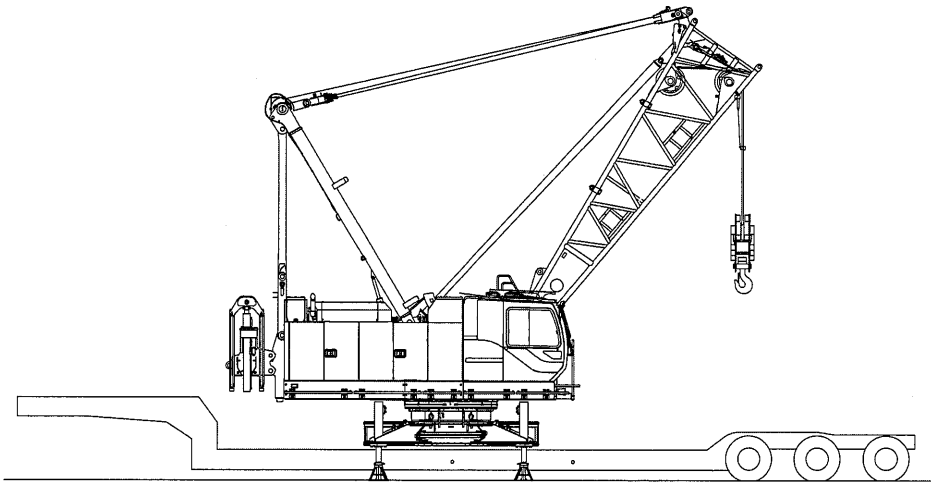

- Lift the main machinery further up and let the trailer go out under the main machinery.
Ground clearance of the main machinery :
1,093 mm (3 ft. 7 in.)

CAUTION

Extend the four vertical cylinders so that the upper machinery is at level.

CAUTION

When unloading the machinery from the trailer, bundle and secure the propel, high/low speed select and drain hoses together to the lower machinery so that they are not damaged or crushed.

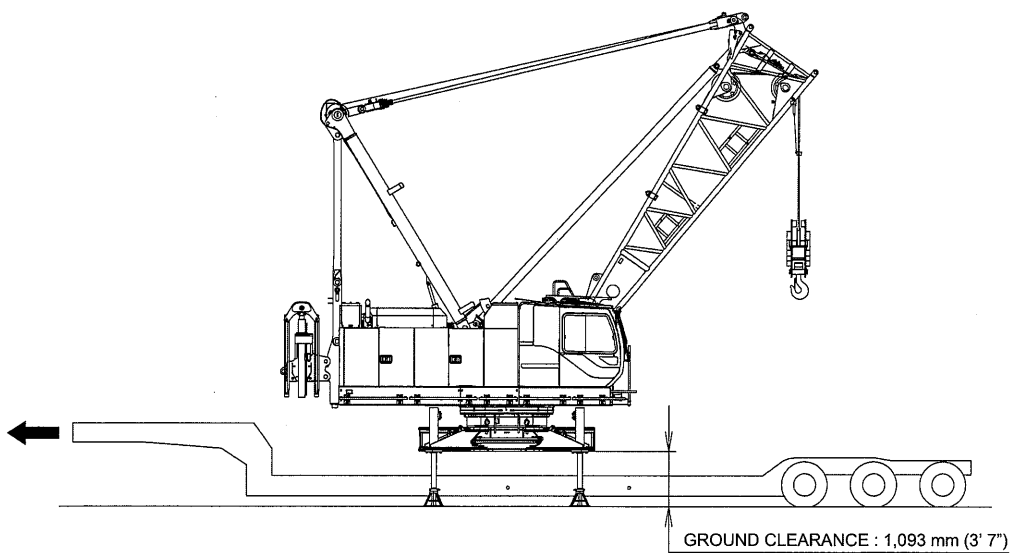

8. Retract the vertical cylinder until the clearance between the lower machinery and the ground becomes approx. 500 mm (1 ft. 8 in.).

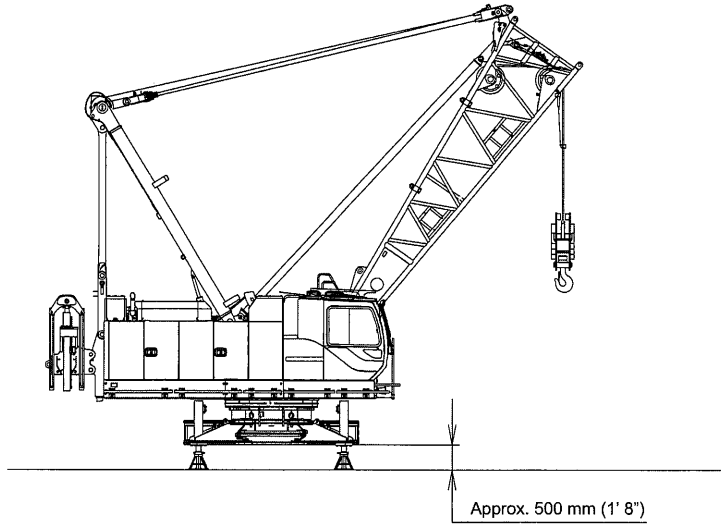

4.2.2 CRAWLER INSTALLATION

1. Preparation of crawler frame installation (Using translifter)

There are two ways of the crawler frame installation, one with self installation using the boom base of the main machinery and the other using an assist crane.

Perform safer way as required.

TOOL

- Translifter
- Attached tool set
- Assist Crane (25 t capacity)
(In case using an assist crane)
- Protective cloth (for lifting sling)
- Sling wire rope 2 pieces (attached)

This article explains the installation of both crawlers using the translifter from the condition that the counterweight is removed, the gantry is lowered and the translifter piping has been connected.

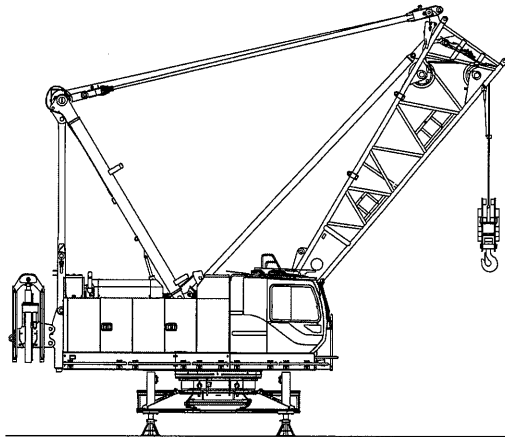

⚠ DANGER

When the translifter is to be used, set the main machinery on level and firm ground.

When the translifter is used on inclined or soft ground, a serious accident such as overturning of the main machinery or damaging the translifter may be caused.

Failure to observe this precaution may result in a serious accident.

⚠ DANGER

When the translifter is to be used, ensure to remove all the counterweights and the carbody weight.

If the translifters are used with these weights installed, a serious accident such as overturning of the main machinery or damaging the translifter may be caused.

Failure to observe this precaution may result in a serious accident.

⚠ DANGER

Crane work prohibited if translifter is at “transport with crawler position”.

If the machine swings at this position, the machine would overturn to rear side.

Ensure to set the machine to “translifter work position”.

Failure to observe this precaution may result in a serious injury or loss of life.

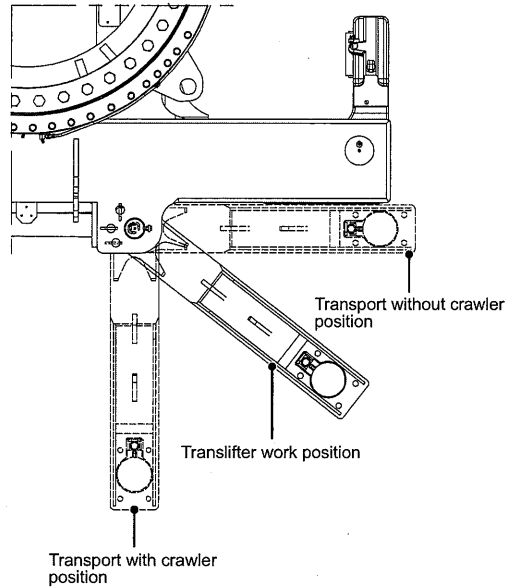

4

⚠ WARNING

Check if there is any abnormality on the ground condition of the float contacting area to prevent overturning of the machine.

Failure to observe this precaution may result in a serious accident.

- (1) Swing the upper machinery to 90 degrees against the axle direction to install the crawlers.
- (2) Set the axle extension to the extended position. Turn all four axle extensions for 90 degrees toward outside to make them parallel to the axles.

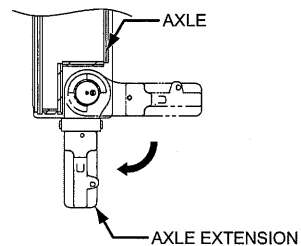
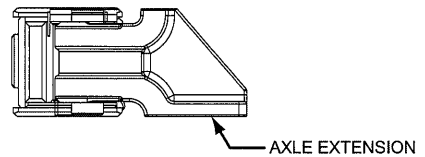

- (3) Set the bracket (t) as shown at all four locations.

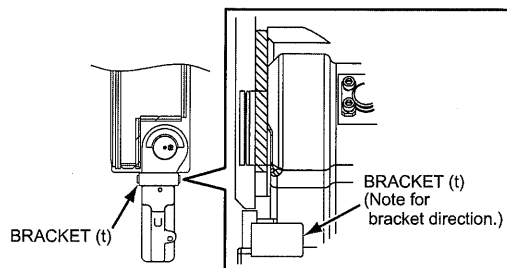

- (4) Turn the upper machinery front to the connector side of the translifter remote control box of the lower machinery.
- (5) Ensure to engage the swing brake and swing lock after swing.
- (6) Check to see that all four vertical cylinders are contacting on the ground.

- (7) Set the clearance from the lower surface of the axle to the ground as approx. 800 mm (2 ft. 8 in.).

At this time, adjust the height by checking the level gauge to keep the lower machinery horizontal.

- (8) Check to see that clearance adjusting shims between the crawler and axle are removed.

⚠ DANGER

Do not swing when the crawler/propel hydraulic hoses are to be connected to prevent accident of being caught.

Failure to observe this precaution may result in serious injuries or loss of life.

4

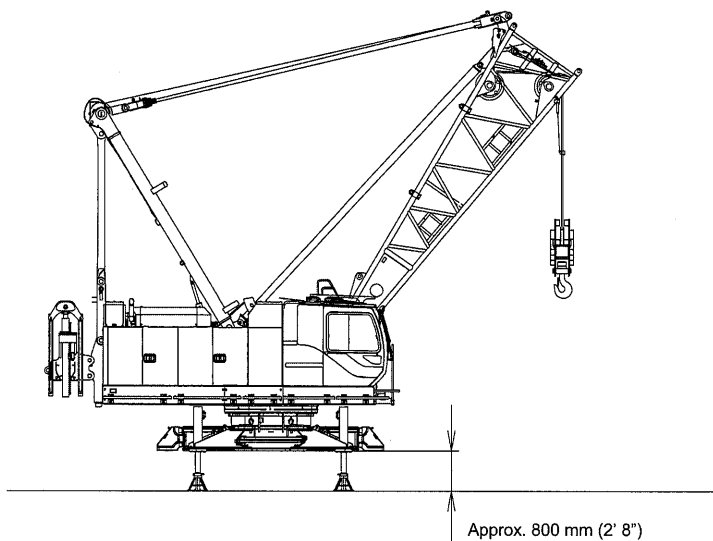

2. Installation of the first crawler

- (1) Bring the trailer with the first crawler as close as possible to the machine.
Make sure the crawler is turned in the proper direction.
The upper machine can swing 360 degrees with lifting the first crawler.
(Without the other side of the crawler installed.)

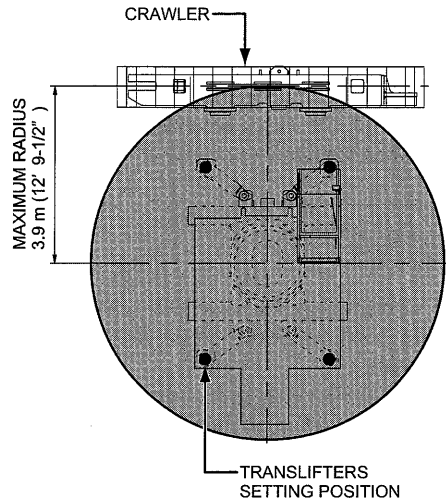

⚠ DANGER

Do not exceed 3.9 m (12 ft. 9-1/2 in.) load radius. Otherwise the machine may tip over. Failure to observe this precaution may result in a serious injury or loss of life.

- (2) Swing the upper structure to orient it toward the crawler.

⚠ DANGER

Do not operate the machine abruptly when the machine is standing with transliifter. Failure to observe this precaution may result in a serious injury or loss of life.

- (3) Ensure that the crawler connecting links are connected.
- (4) Insert the link between the carbody bracket (h) and ensure that the guide pins (k) are connected.

(Same work on 4 locations)

Handling of the crawler connecting links differs between those of "LF", "RR" and those of "RF", "LR".

Place pins (la) of left front side and right rear side against the plate (m).

Pull out pins (lb) of right front and left rear side in advance.

4

WARNING

Do not put finger or hand into pin hole.

Failure to observe this precaution may result in a serious injury.

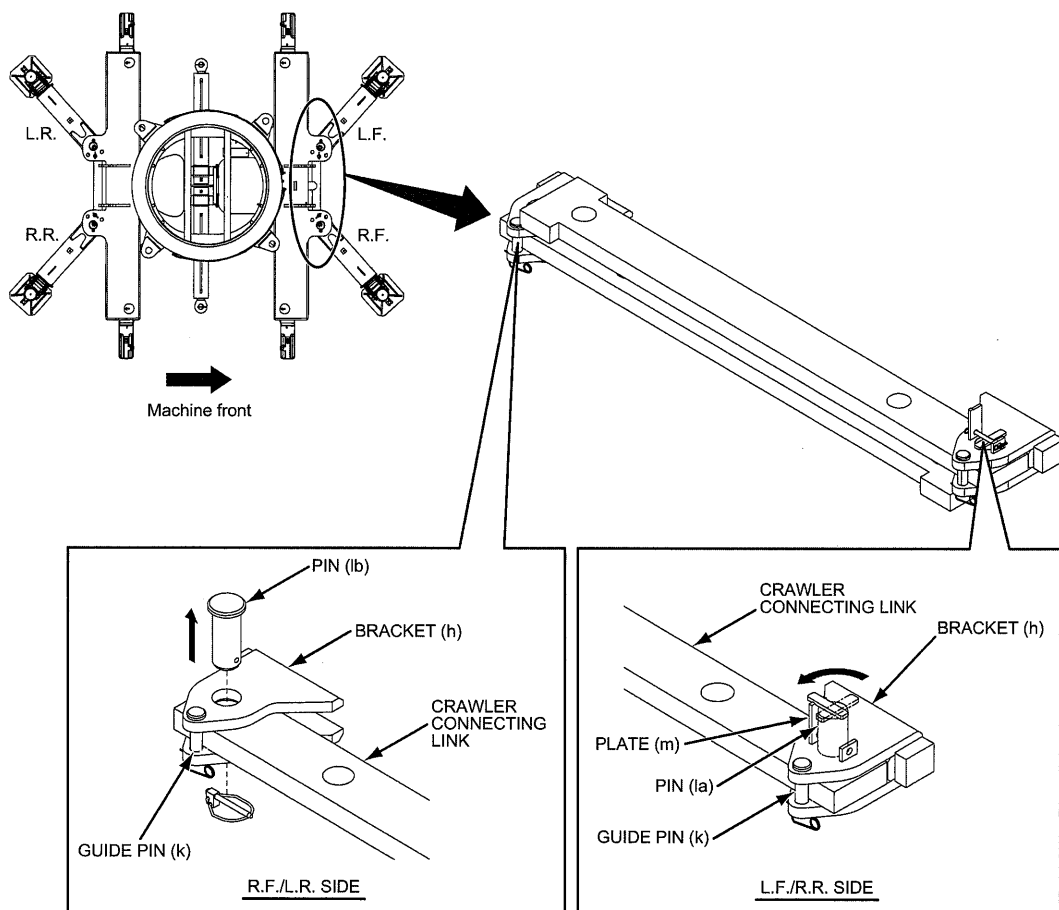

- (5) Apply grease on upper, lower and side face of the axle to make crawler sliding easier.
(4 locations)
- (6) Lift up the crawler with the lower boom.

Crawler weight :
11.9 t (26,301 lbs) (one side)

Hold the right crawler, use corner protection materials so that wire does not bite into shoes.

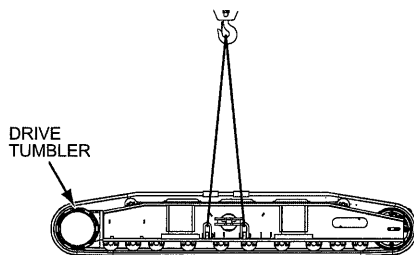
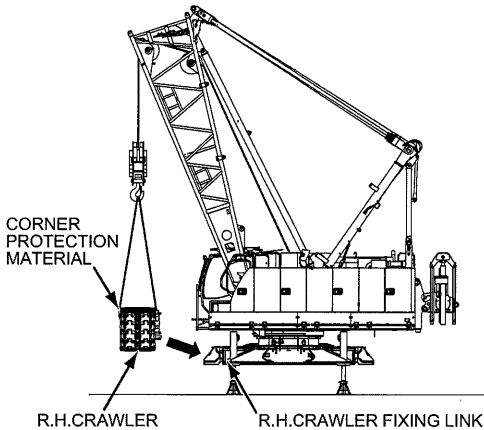

In case of using an assist crane, follows the procedure as shown right.

CAUTION

Control the assist crane to prevent the sling wire rope from interfering with the deck during the crawler lifting in.

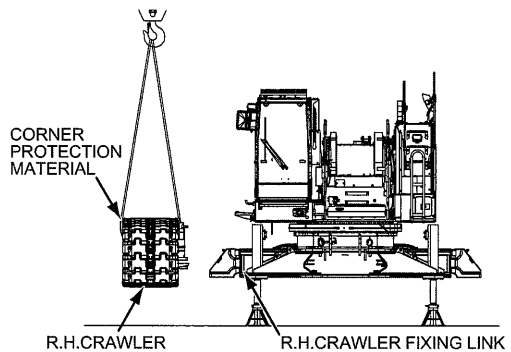

- (7) Insert the crawler to the front and rear axle extensions with the lower boom.
- (8) Remove the retaining pin (j) and pull out the pin (n).
Extend the crawler ext/ret cylinder with the remote control switch and connect the crawler frame and the crawler ext/ret cylinder. Secure the crawler and cylinder with the pin (n).

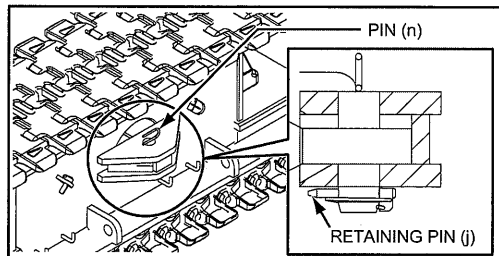

⚠ DANGER

Check to see that no personnel is between the crawler and the main machinery to prevent accident of being caught.
Failure to observe this precaution may result in serious injuries or loss of life.

⚠ WARNING

Do not put finger or hand into pin hole.
Failure to observe this precaution may result in a serious injury.

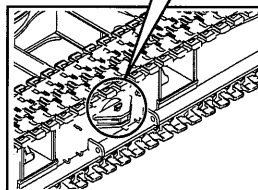

- (9) While holding the crawler with the lower boom, retract the extend cylinder and pull in the crawler to inner side of the work (extended) position.
- (10) Extend the link and insert the pin (p).
- (11) Rotate the pin (1a) which has been placed against the plate and place it against the crawler connecting link. (Left front side)

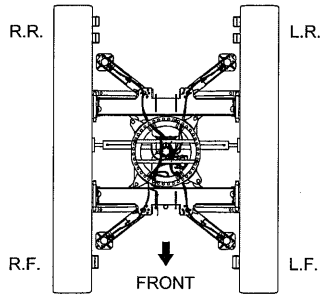

⚠ WARNING

Do not put finger or hand into pin hole.
Failure to observe this precaution may result in a serious injury.

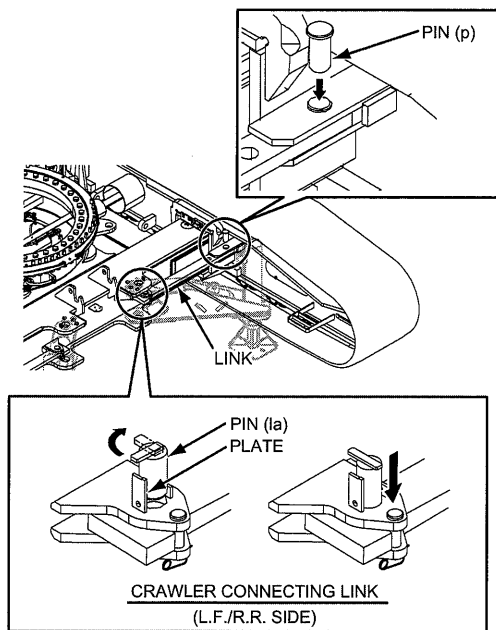
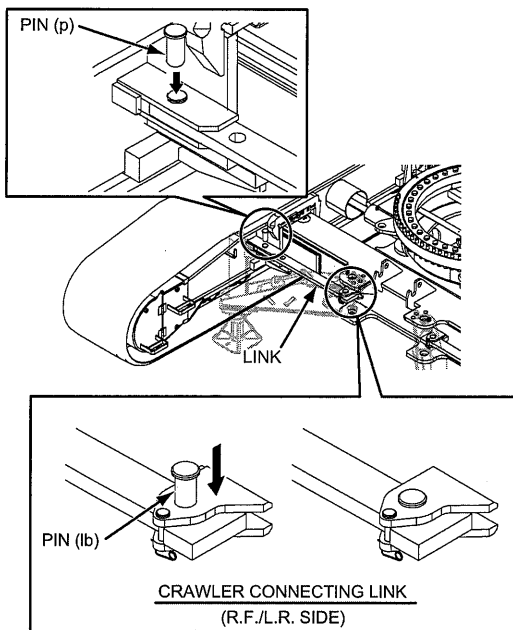

- (12) While holding the crawler with the lower boom, extend the crawler to the work position by extending the cylinder and check that the pin (1a) and (1b) which has been placed on the link is inserted into the link hole.

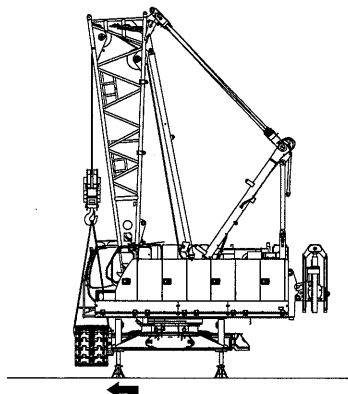

In case of using an assist crane, follows the procedure as shown right.

CAUTION

In order to prevent interference of wire rope with the deck when the crawler is retracted, loosen the sling wire rope just before the deck and inner side of the shoe upper face comes close (approx. 50 mm [2 in.]).

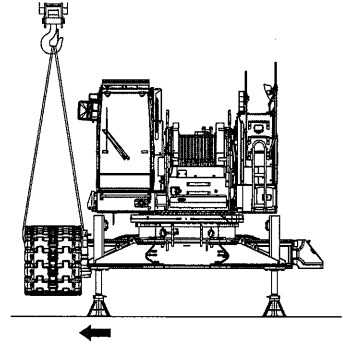

CAUTION

When the crawler is pulled in with the extend cylinder, lift up the main machinery with the translifter and hold it in horizontal position. If the crawler is inclined for right or left way, keep crawler in horizontal position by extend cylinder or vertical cylinder.

Pulling the crawler forcibly with the ext/ret cylinder while the crawler is inclined may damage the crawler.

- (13) Set the retaining pin, lock pin as shown right to prevent pin (1a) and (1b) from coming out.
(2 locations on one side)

WARNING

Do not put finger or hand into pin hole.
Failure to observe this precaution may result in a serious injury.

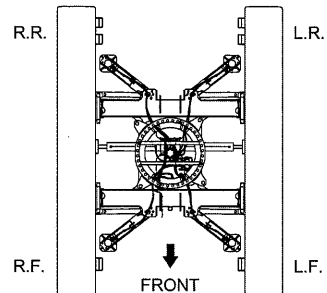
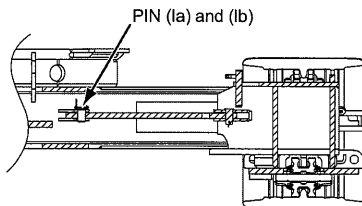

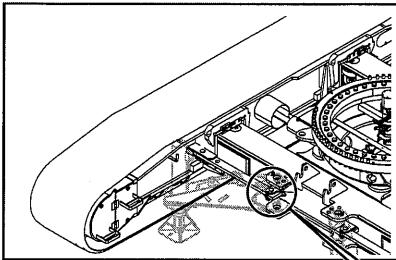
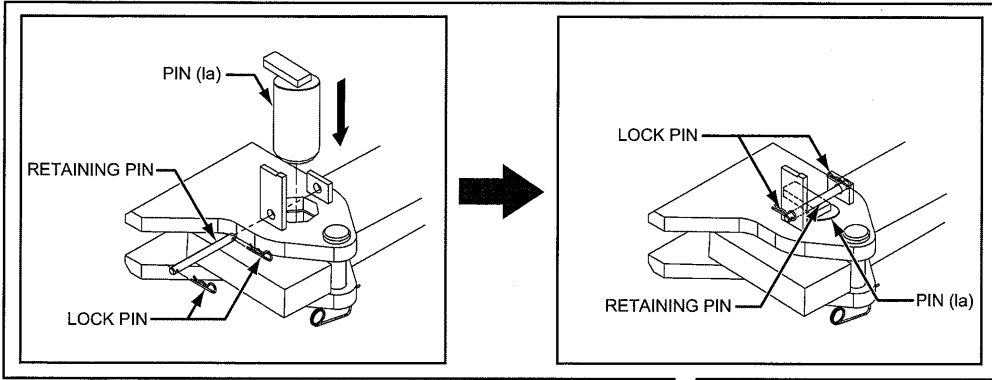

CRAWLER CONNECTING LINK
(R.F./L.R. SIDE)

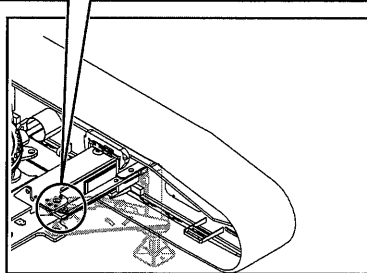

CRAWLER CONNECTING LINK
(L.F./R.R. SIDE)

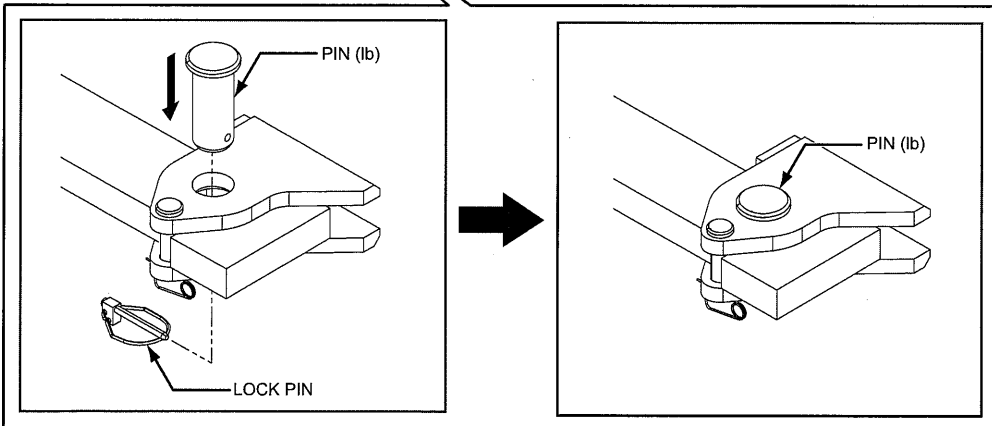

3. Installation of the second crawler

- (1) Bring the trailer with the second crawler as close to the machine as possible.
Ensure adequate clearance for trailer.
Make sure the crawler is in the proper direction.

⚠ DANGER

Do not swing over center of the translifter cylinders (90 degrees) while lifting the second crawler.

Do not exceed 3.9 m (12 ft. 9-1/2 in.) load radius.

Otherwise the machine may overturn.

Crawler lift is permitted only in the area shown.

Failure to observe this precaution may result in a serious accident.

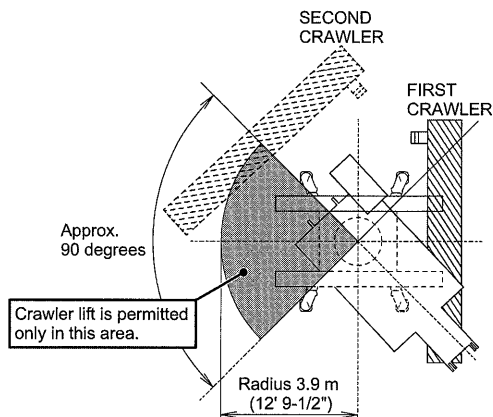

- (2) Swing the upper structure to orient it toward the crawler.

⚠ DANGER

Do not operate the machine abruptly when the machine is standing on translifter.

Failure to observe this precaution may result in a serious accident.

- (3) Install the other crawler in the same procedure.

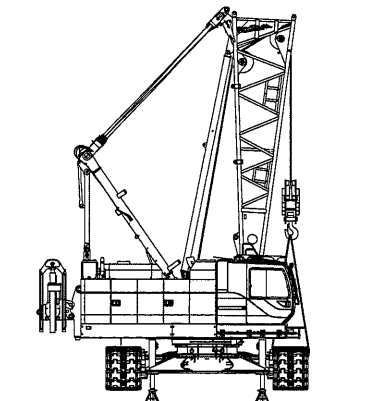

In case of using an assist crane, install with the procedure as shown right.

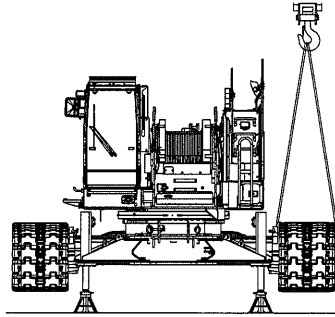

- (4) When both crawlers are installed completely, keep the main machinery horizontally and retract the four vertical cylinders until the crawlers are placed completely on the ground.

- (5) Swing the main machinery to make the clearance between the crawler and axle larger and insert the adjusting shims. Each shim has its number stamped. Install the matching one with that of frame side. (Four places total at front and rear axles)

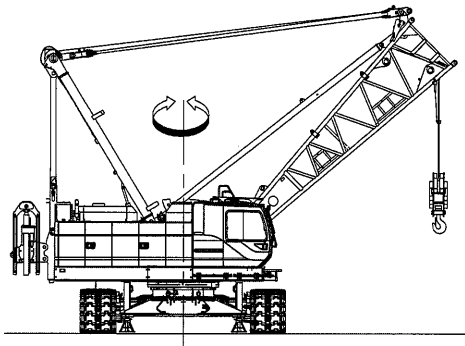

CAUTION

Ensure to insert the adjusting shims in the clearance between the crawler and axle. Otherwise the crawler would become inclined and would cause premature wear of the shoes or the lower rollers on one side only.

WARNING

Do not put finger or hand into the clearance between the crawler and the axle when inserting or removing the shims to prevent serious injury. Failure to observe this precaution may result in a serious injury.

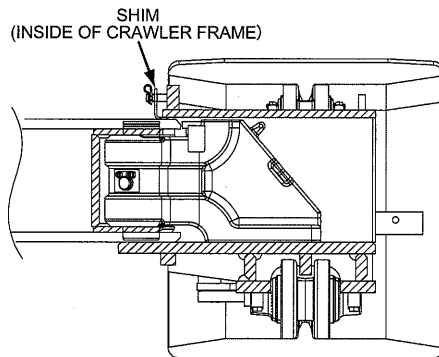

- (6) Take out the pin (n) which has connected the crawler ext/ret cylinder and the crawler then fully retract the cylinder.
 Confirm that the cylinder has been retracted and then insert the pin (n) to the pin hole of the crawler side bracket and insert the retaining pin (j).
 Perform on both sides.

⚠ WARNING

Do not put finger or hand into pin hole.
Failure to observe this precaution may result in a serious injury.

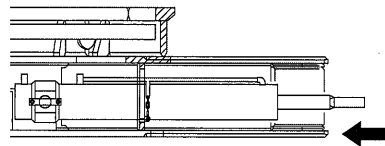
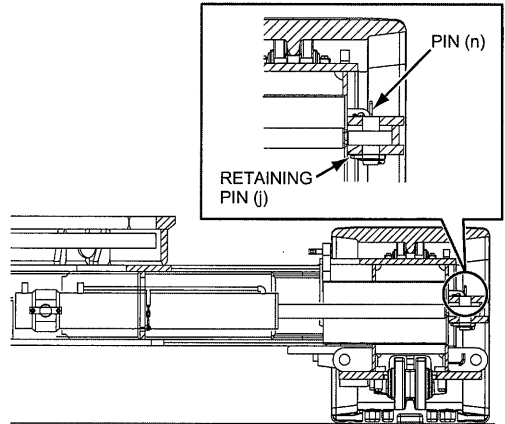

- (7) After installation of carbody weight, stow the float to its stowing position of the carbody weight.

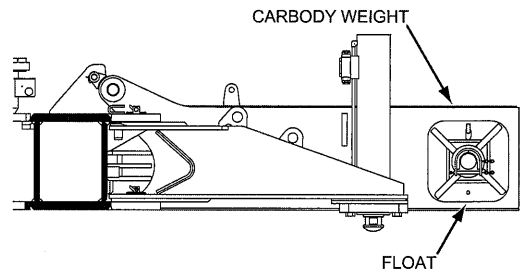

- (8) When both crawler installation is completed, stop the engine.

- (9) When the propel motor cover bolt (r) are taken out, the cover opens.
Connect the propel hydraulic hoses for both (right and left) at their quick coupler portions.
(4 pieces on one side)
After connection, pull the hose to check for firm connection on both sides.

BOLT (r) (M16)
HEX.WRENCH
ZT22A14000 (2 FACE WIDTH : 14 mm (1"))

COVER

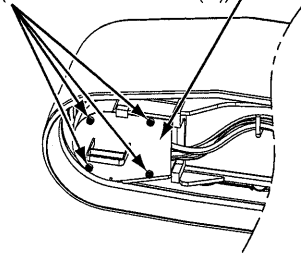

QUICK COUPLER

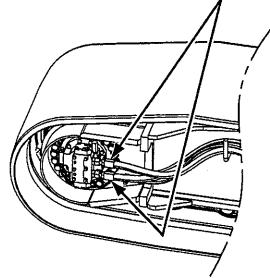

⚠ DANGER

Do not swing when the propel hydraulic hoses are being connected or disconnected to prevent accident of being caught.
Failure to observe this precaution may result in serious injuries or loss of life.

⚠ CAUTION

Connect the quick coupler after the engine is stopped and the pressure is lowered.
If the pressure is remained, connection would be impossible or oil would spill out.
Connect the quick coupler after the dust, dirt are wiped off.
If the quick coupler connection is incomplete, oil leak or damage to the propel motor and/or reduction unit may occur.

4.2.3 CAB STEP EXTENSION

Steps provided at the cab door are for the safe access to the operator cab.

Extend the steps during work, and stow or remove for transportation.

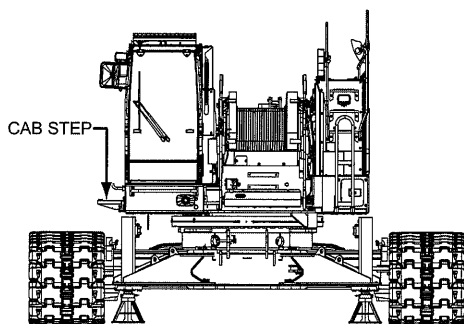

4

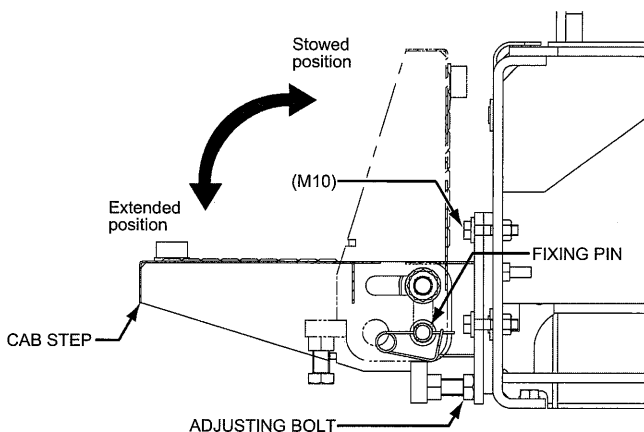

EXTENSION

1. Remove the fixing pin and lift up the outer end of the step full and then rotate it toward outer side to extend to horizontal position.
2. If the step is not horizontal after extended, adjust two bolts to make the step in horizontal position.
3. Secure one side of each step with the fixing pin to prevent it from rotating.

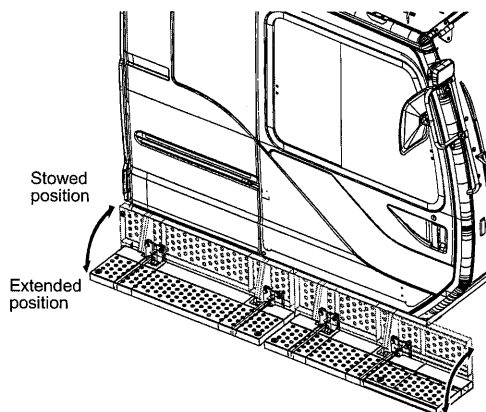

4.2.4 CARBODY WEIGHT INSTALLATION

This machine's carbody weight is composed of two pieces.

Never use the carbody weight other than specified one.

There are two ways of the carbody weight installation, one with self installation using the boom base of the main machinery and the other using an assist crane. Perform safer way as required.

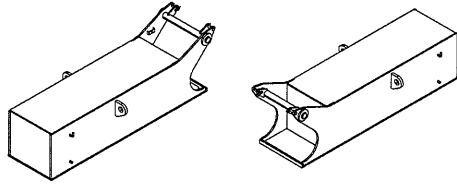

EACH WEIGHT

Carbody weight	Weight
No.1 WEIGHT	3.25 t (7,165 lbs)
No.2 WEIGHT	3.25 t (7,165 lbs)

1. Preparation of carbody weight Installation

Before installing the carbody weight, check that the machine is in the following conditions.

- The gantry is in "WORK" position.
- Main machinery is placed on firm and level ground.
- The crawler is extended to "WORK" position.

WARNING

Check the swing and propel stability (P.4-1) to prevent the machine from overturning. Failure to observe this precaution may result in a serious accident.

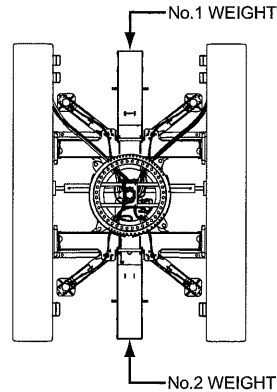

When installing the carbody weight, prepare the tools listed as following.

TOOL

- Attached tool set
- Assist crane (25 t capacity or larger)
(In case using an assist crane)
- Sling wire rope
(25 mm dia. × 8 m [26 ft. 2-15/16 in.] × 2)
- Shackle (10 t) × 2
(P/N : 2420Z2134D1)

There are two way to install the carbody weight.

One is to use an assist crane and the other is to use the machine boom base.

 **DANGER**

Do not stand under lifted carbody weight or between carbody weight and the basic machine to avoid accident of drop or being caught.

Failure to observe this precaution may result in a serious injury or loss of life.

4

Lift the carbody weights with the boom base or assist crane, and install them by hooking them with the carbody brackets. When removing them, lift them with the boom base or assist crane in a similar manner.

2. Carbody weight installation

(1) Installation of No.1 carbody weight

- (A) Attach the shackle to the lifting bracket of the carbody weight and lift up with the lower boom or assist crane.

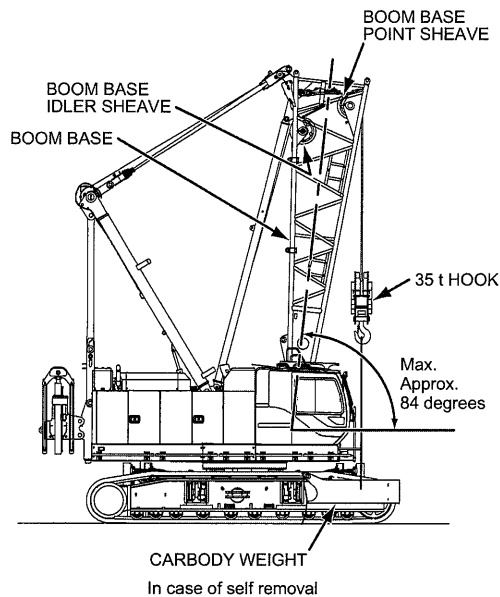

⚠ DANGER

Do not allow any persons to enter under the lifting carbody weight or between the carbody weight and main machinery to prevent accident of falling or being caught.

Failure to observe this precaution may result in serious injuries.

⚠ WARNING

The load line can break if the hook block contacts the end of the boom.

This is called "two blocking"

Two blocking can be caused by lowering the boom without paying out the load line.

Two blocking can pull jibs and lattice crane booms over backwards or cause damage to the tip.

Always keep adequate space between the hook block and boom point.

Lower the hook when lowering the boom.

Failure to observe this precaution may result in a serious accident.

- (B) Install the (a) area of the carbody weight to the (b) area of the carbody.

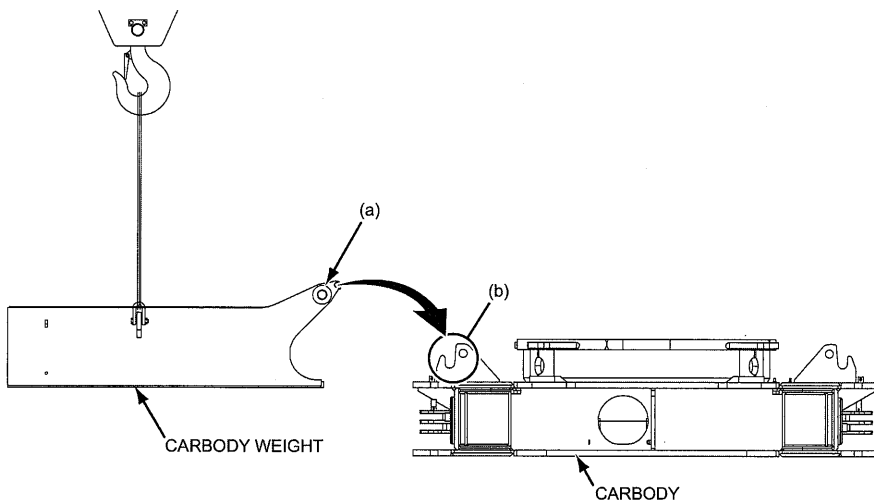

4

- (C) For both No.1 and No.2 carbody weight, insert the carbody weight secure pin (a) and secure it with the lock pin (b) on right and left hand sides.

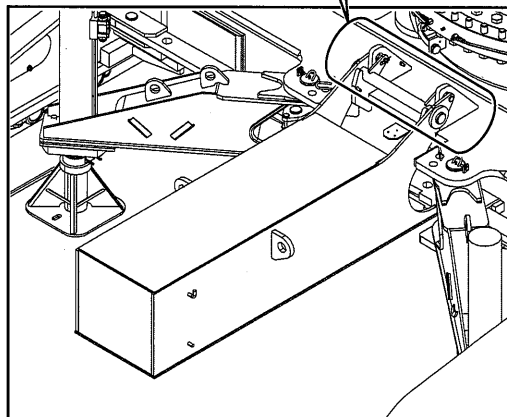
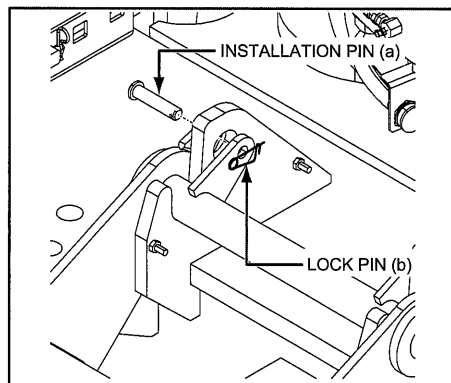

- (2) Installing No.2 carbody weight
Install No.2 carbody weight in the same manner as for No.1 carbody weight.
- (3) Set the translifter as shown right.
Stow the float to the carbody weight.

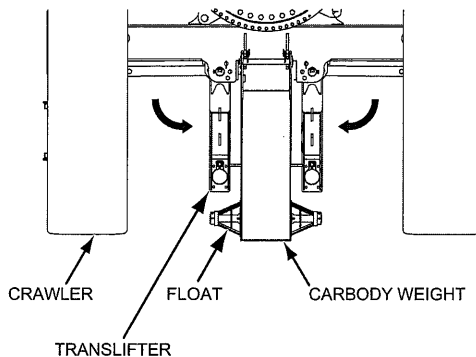

- (4) For the model equipped with weight detect harness (CN-914F) at the front side of the main machinery, connect the harness and connect the caps together.
The detect harness installed on the rear side weight is not to be used.

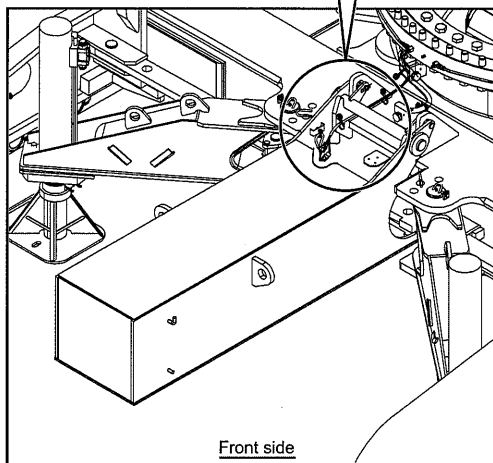
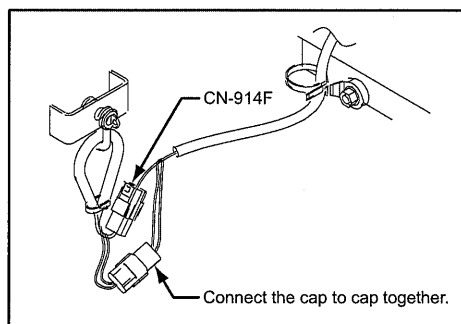

When setting the LMI, ensure to select the item matched with the actual condition.

If wrong item is selected, an error [ML-ME064] will appear on the monitor and buzzer will sound.

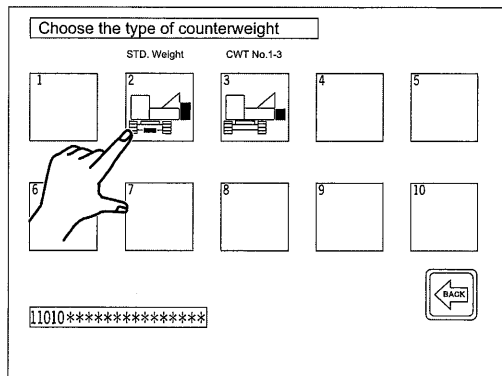

4

IN CASE OF WEIGHT REDUCED SPECIFICATION

In case of the weight reduced specification, if the carbody weight is not equipped, leave the main machinery harness cap as is.

4.2.5 ASSEMBLING THE COUNTERWEIGHTS (USING SELF REMOVAL DEVICE)

EACH WEIGHT

Counterweight	Weight
WEIGHT (1)	11.6 t (25,600 lbs)
WEIGHT (2) (4)	5.75 t (12,680 lbs)
WEIGHT (3) (5)	5.75 t (12,680 lbs)

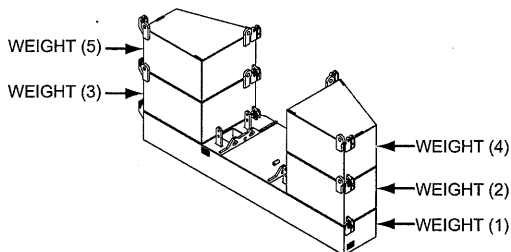

The following conditions must be satisfied.

- The ground is firm and level.
- Select a place for counterweight assembly.
- Place blocking on the ground and place the WEIGHT (1) on top.
Such practice will ease the install process.

⚠ WARNING

When making lifts, strictly follow the capacity charts supplied by the manufacturer for determining the loads that can be handled.

Failure to observe this precaution may result in a serious accident.

⚠ WARNING

The load line can break if the hook block contacts the end of the boom. This is called "two blocking". The two blocking can be caused by lowering the boom without paying out the load line.

The two blocking can pull jibs and lattice crane booms over backwards or cause damage to the tip.

Always keep adequate space between the hook block and boom point.

Lower the hook when lowering the boom.

Failure to observe this precaution may result in a serious accident.

CAUTION

Check the labels (allow [a1] or [a2]) to confirm that the counterweights are of the specified ones for the main machinery before assembling.

25,600 lbs
11,600 kg

Detail (a)

1. Raise the links then fix the links with spring pins and lock pins.

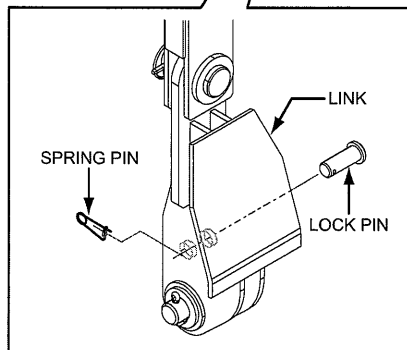
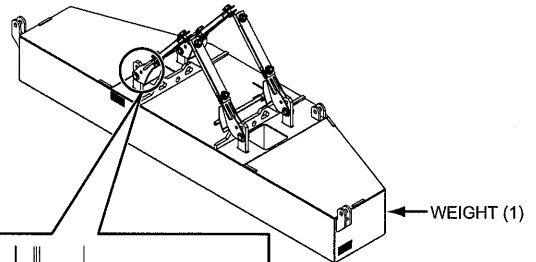
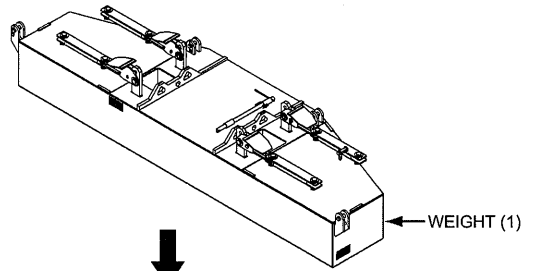
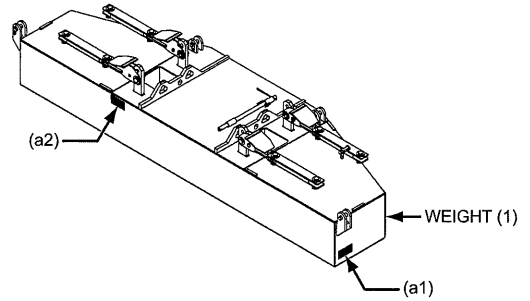

2. Place WEIGHT (1) on the flat ground.

3. Lift up right and left WEIGHTS (2) and (3) with the crane and place them on WEIGHT (1).

⚠ WARNING

**Do not lift more than one weight at a time.
Lifting brackets may break.
Failure to observe this precaution may result in a
serious injury or loss of life.**

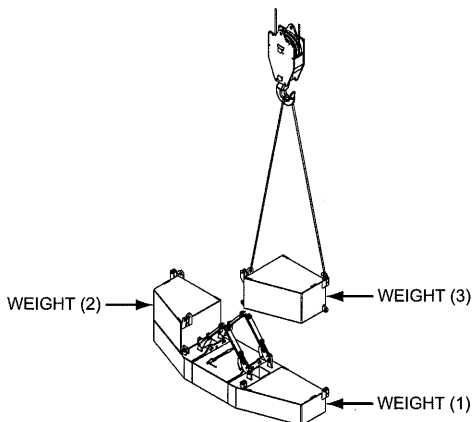
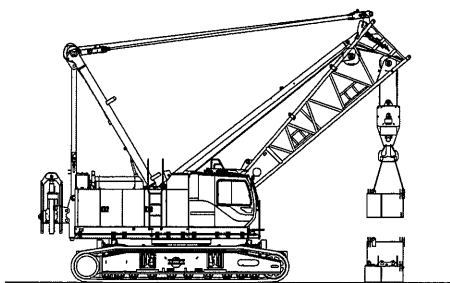

⚠ DANGER

**Do not enter under the counterweight or stand
between the weight and surrounding object.
Failure to observe this precaution may result in a
serious injury or loss of life.**

- Place right and left WEIGHTS (4) and (5) in the same way as for the WEIGHTS (2) and (3).

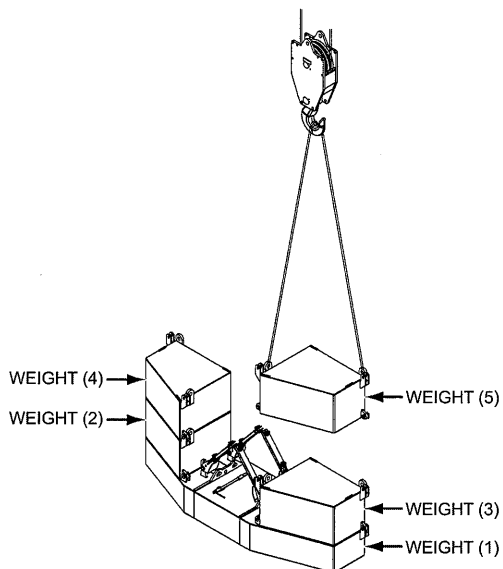

- Secure right and left counterweights with the connecting pins accordingly and retain the connecting pins with the spring pins. (8 locations)

⚠ WARNING

Do not insert finger or hand into a pin hole when aligning, inserting or removing pin.
Failure to observe this precaution may result in a serious injury or loss of life.

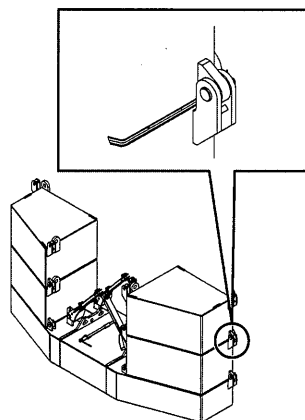

4.2.6 REMOVING THE HOOK BLOCK FROM THE BOOM BASE

- Lower the boom base and hook block.
- Disconnect the hook overhoist limit switch.
- Reeve the wire rope to the front drum.

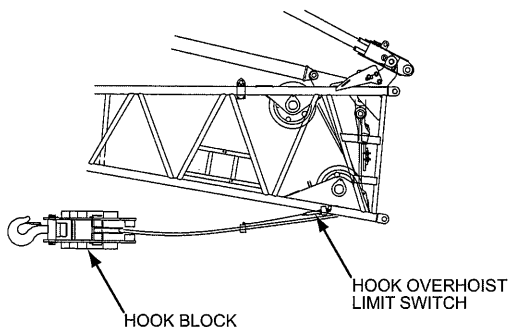

4.2.7 SETTING THE COUNTERWEIGHT LINK

Lean the links on WEIGHT (1) against the plate on WEIGHT (1) as shown on "View from Y" by removing pin and lock pin.

⚠ WARNING

Do not insert finger or hand into a pin hole when aligning, inserting or removing pin.
Failure to observe this precaution may result in a serious injury or loss of life.

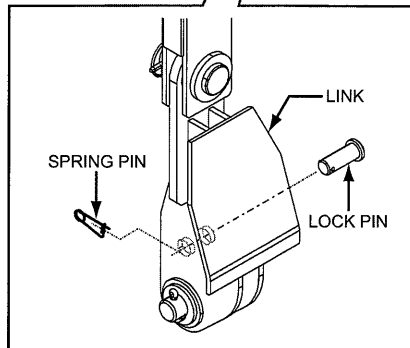
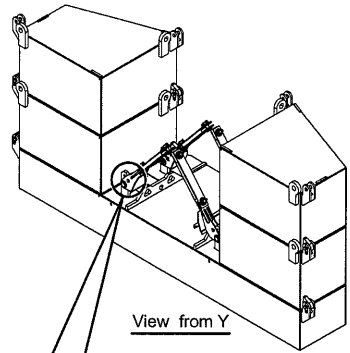
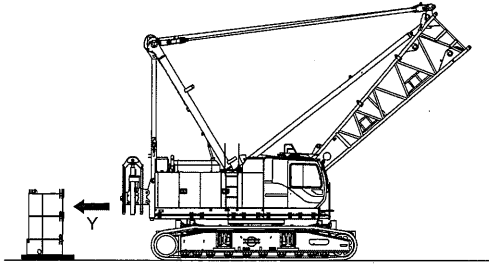

4.2.8 INSTALLATION OF COUNTERWEIGHTS TO MACHINE (USING SELF REMOVAL DEVICE)

▲ CAUTION

Perform the work on firm and level ground.
(within 1% of ground inclination).

If the ground inclination exceeds 1%, bending load would be applied on counterweight raising cylinder and cylinder rod may be damaged.

▲ CAUTION

Perform the work with engine speed 1,000 min⁻¹
(1,000 rpm) or less.

If exceeded, the cylinder speed becomes faster and excessive force could be applied on the cylinder at start or stop of motion.

This may damage the cylinder rod.

▲ WARNING

Place a signal person to prevent accident from moving machinery or running ropes.

Failure to observe this precaution may result in a serious accident or injury.

1. Installation of counterweight lifting link

- (1) Propel the machine to the position that the counterweight lifting links can be connected to the counterweight lifting point.
-

▲ CAUTION

Slowly propel the machine while paying attention to prevent any interference of the basic machine with the counterweights.

(2) Set the machine horizontally.

WARNING

Before installing the counterweight, make sure that the machine is at level.
If needed use mats to correct it.
Do not use the translifters when lifting counterweight by the cylinder.
Failure to observe these warnings may result in a serious accident.

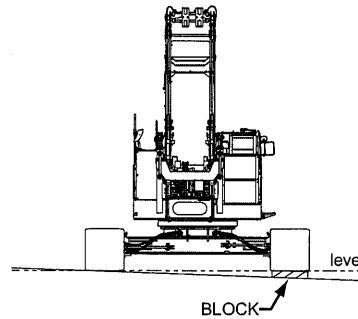
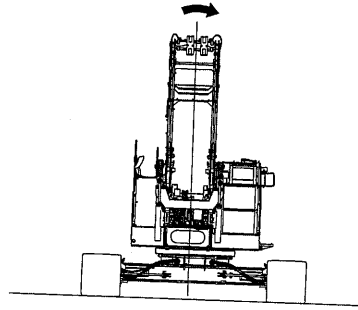

View from rear

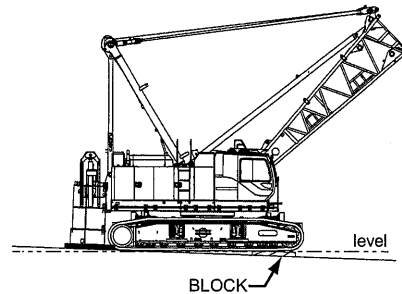
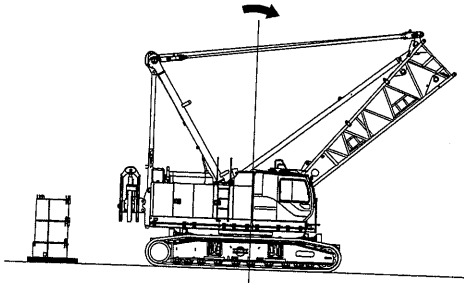
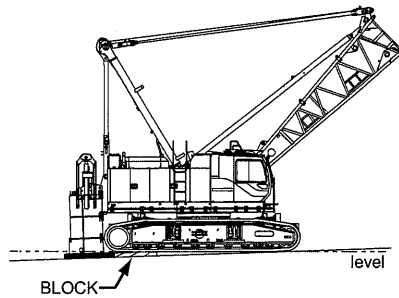
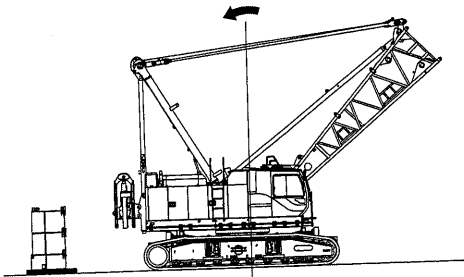

- (3) Install the counterweight lifting links to the counterweight.
- (A) Set the counterweight link up right at the base by setting pin and spring pin. (4 locations)
- (B) Connect the links by pin and lock pins and spring pins as shown.

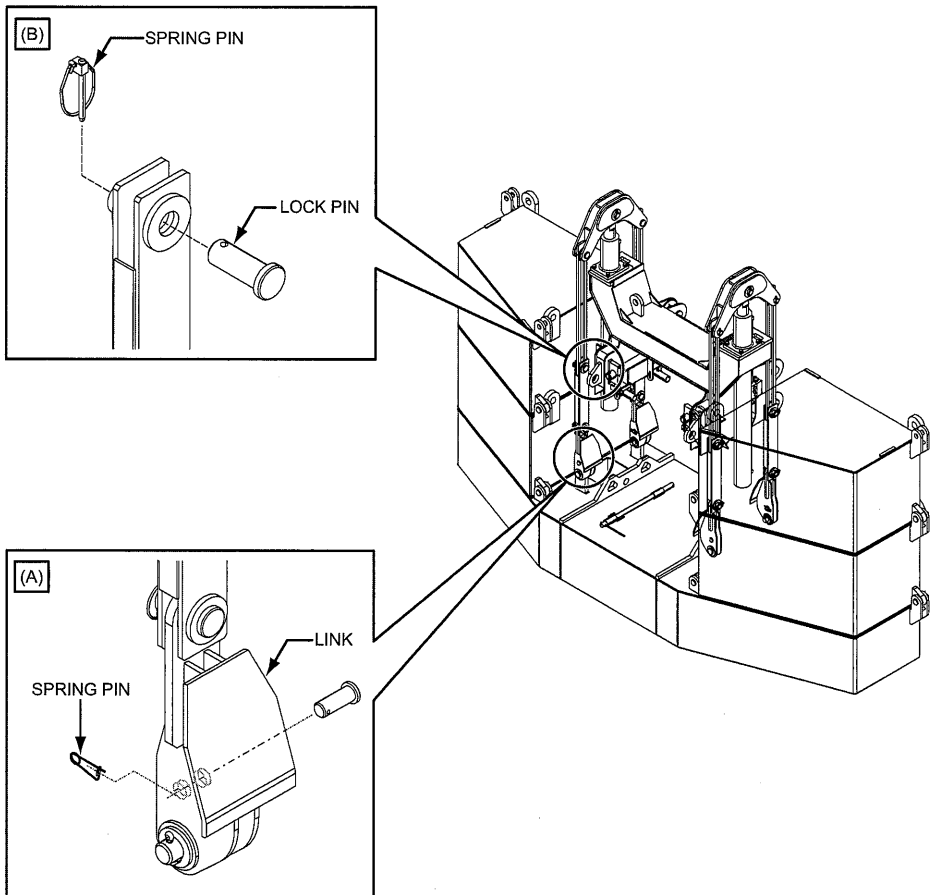

WARNING

Do not insert finger or hand into a pin hole when aligning, inserting or removing pin.
Failure to observe this precaution may result in a serious injury or loss of life.

2. Installation of counterweights to base machine

- (1) Open the guard and connect the remote control cable to the receptacle.

⚠ DANGER

When lifting/lowering the counterweights, keep the motions of the right and left cylinders even and horizontal.

Failure to observe this precaution may result in a serious accident.

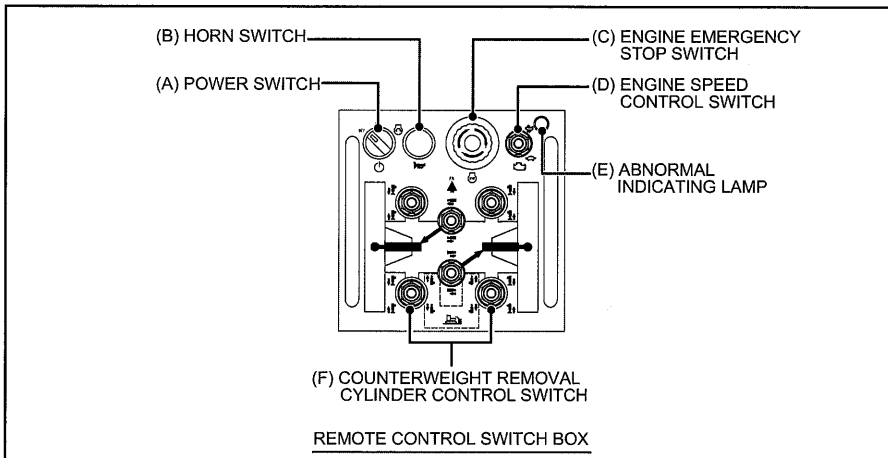
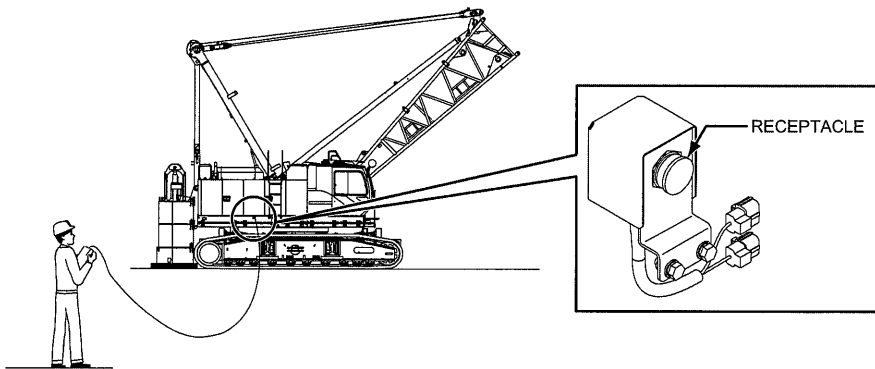

⚠ CAUTION

When raising or lowering the counterweight, keep the both counterweight cylinders even by operating the both at the same time.

If the counterweight becomes uneven, ALWAYS correct the situation by RAISING the "LOWER" side.

If the higher side's cylinder is lowered, the load will be concentrated on that cylinder and may be damaged.

4

(A) Power switch

OFF	Power off. Turning to this position stops the engine.
ON	Power is supplied to crane portion.
	Engine starts. When released, the switch automatically return to ON position.

(B) Horn switch

Press this switch to sound the horn.



(C) Engine emergency stop switch

Press this switch to stop the engine in emergency.

The switch stays at depressed position.

To reset, turn the switch to right or pull.

(D) Engine speed control switch





	Increase the engine speed.
	Decrease the engine speed.

(E) Abnormal indicating lamp

This lamp turns ON when the engine abnormality occurs.

When this lamp is ON, check the detail of abnormality by the cab monitor and take appropriate action.

- (F) Counterweight removal cylinder control switch
This switch is used to control the counterweight removal cylinder.

 or 	Cylinder extends (jack up)
 or 	Cylinder retracts (jack down)

- (2) Start the engine with the remote control and the speed to approx. 1000 min⁻¹ (1,000 rpm).
(3) Operate the remote control to lift the counterweight.
-

 **DANGER**

Slowly lift/lower the counterweight.
Failure to observe this precaution may result in a serious accident.

 **DANGER**

When lifting/lowering the counterweights, keep the motions of the right and left cylinders even and horizontal.
Failure to observe this precaution may result in a serious accident.

 **DANGER**

Do not enter under the counterweight or stand between the weight and surrounding object.
Failure to observe this precaution may result in a serious injury or loss of life.

- (4) Set the counterweight support pins on both sides with using the extension bar.

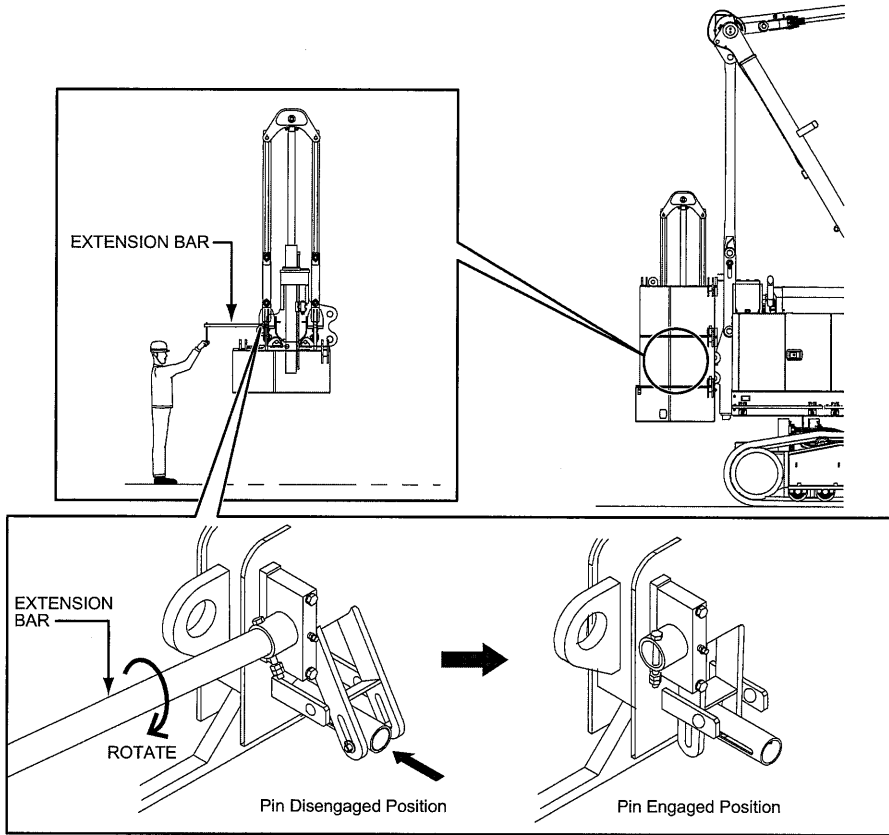

- (5) Retract the cylinder by approx. 50 mm (2 in.).
The counterweight unit is now supported by pin.
- (6) Go up onto WEIGHT (1) with using a ladder.
- (7) Set the lock pin and spring pin on both sides.

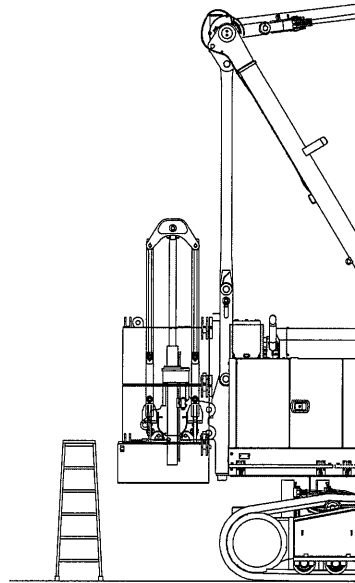
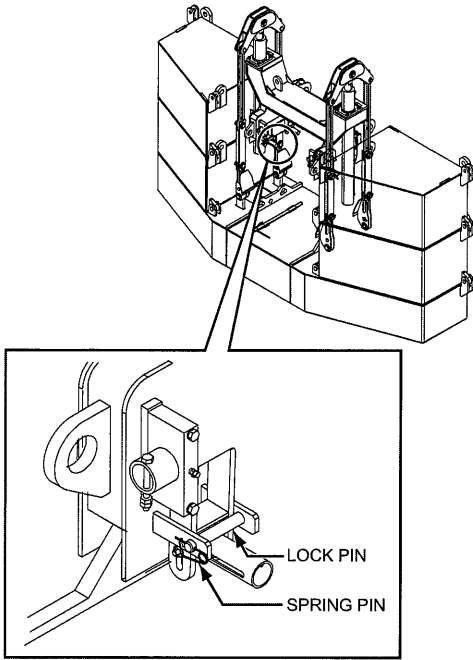

- (8) Fully retract the cylinders.

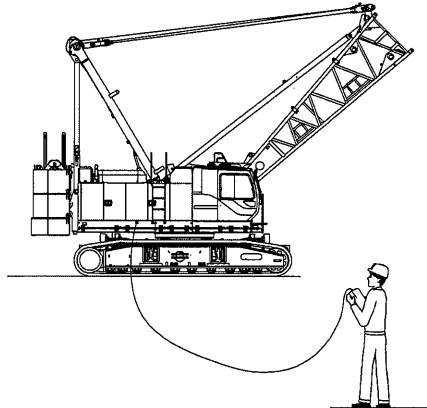
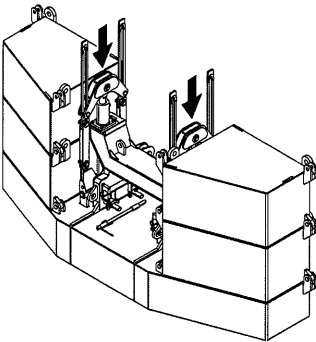

- (9) Turn off the engine then disconnect and store the remote control switch box.

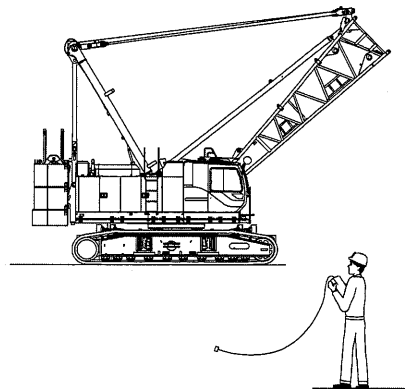

4

- (10) For the model with counterweight quantity detect device is equipped, connect the all detect harnesses.
 Connect the caps together also.
 After connection is completed, secure the harnesses with the clamps provided.

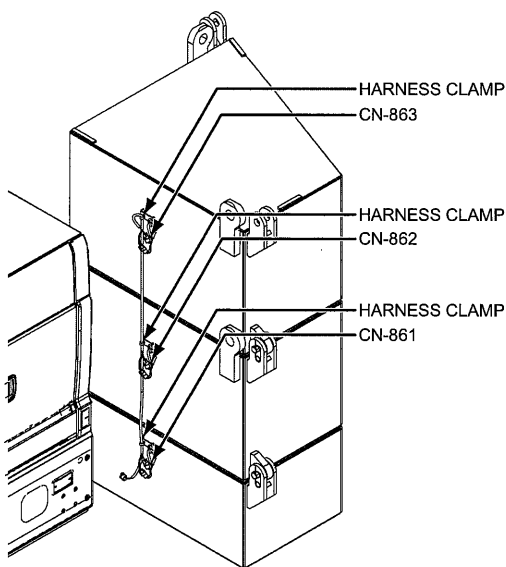

Standard counterweight configuration

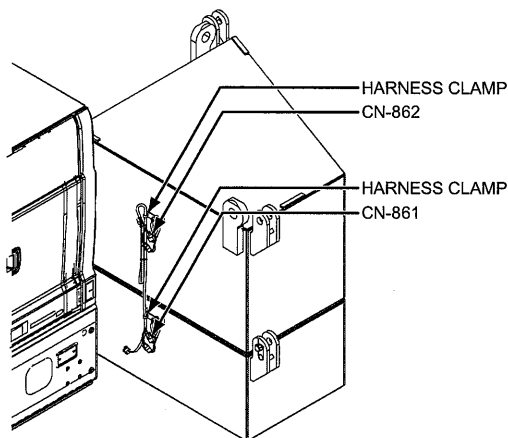

Reduced counterweight configuration

When setting the LMI, ensure to select the item matched with the actual condition.
If wrong item is selected, an error [ML-ME063] will appear on the monitor and buzzer will sound.

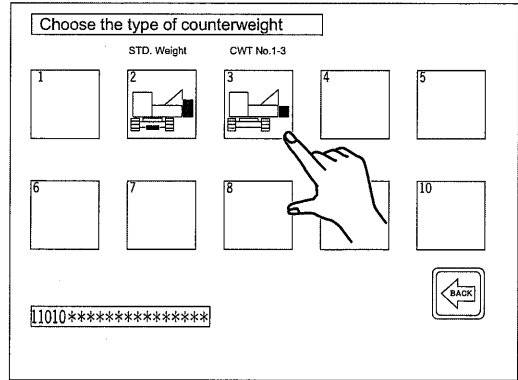

FOR REDUCED COUNTERWEIGHT CONFIGURATION

If the non-standard counterweight configuration is chosen, only connect the available detect harness(es).

4.3 DISASSEMBLY OF MAIN MACHINERY

This article explains disassembly of main machinery and loading to trailer for transportation.



Any work on the main machinery would be dangerous if proper procedure is not taken.

Hold a pre-work meeting to go over the procedure to prevent accident and proceed with the work safely.

Failure to observe these precautions may result in a serious injury or loss of life.



Do not insert finger or hand into a pin hole when aligning, inserting or removing pin.

Failure to observe this precaution may result in a serious injury or loss of life.



The ground where main machinery is placed during assembly or disassembly may receive large load.

Place steel plates on the ground.

Use proper rated assist crane, slings, shackles and other equipment.

Failure to observe these precautions may result in a serious accident.

1. Check point prior to work
 - A qualified supervisor who is competent in the procedures.
 - Hold a pre-work meeting for safety.
Review potential hazards and hazardous locations in the course of work.
 - Make every worker aware of work contents, procedure and signal.
 - Inspect assist crane and other equipment for their condition.

2. Securing place

- Select a firm and level space enough for the task.

Place steel plates or crane mats.

- Assign areas for the assist crane, parts storage and trailer access.
- The ground shall be drained unless the place is in marshes or wetland.

3. Preparation before work

- Secure the setting place of assist crane and prepare the required lifting gears, protective materials and tools.

- Secure the sufficient numbers of workers for the work.

(Crane operators, assistant riggers and signal persons)

- Take appropriate action to keep personnel off the work area other than workers during work.

4. Cautions during transportation work

- During transportation work, install the waterproof cap on the cable end of the hook overhoist preventing device.

During crane work, wire the overhoist cable properly and remove the waterproof cap.

- In case of machine transportation on the trailer, the permit issued by the authority may need to be obtained.

Follow the respective regulation regarding the weight and dimension for transportation.

Refer to the article 8 "DIMENSION, WEIGHT OF EACH COMPONENT" for weight, dimension during disassembly.

4.3.1 REMOVE THE COUNTERWEIGHTS FROM THE MACHINE (USING SELF REMOVAL DEVICE)

⚠ DANGER

Do not enter under the counterweight or stand between the weight and surrounding object.

Failure to observe this precaution may result in a serious injury or loss of life.

1. If the counterweight quantity detect device is equipped, disconnect the detect harnesses installed on all of the counterweights from the main machinery harness.
After disconnection, put the water proof caps on both detect and the main machinery harnesses.

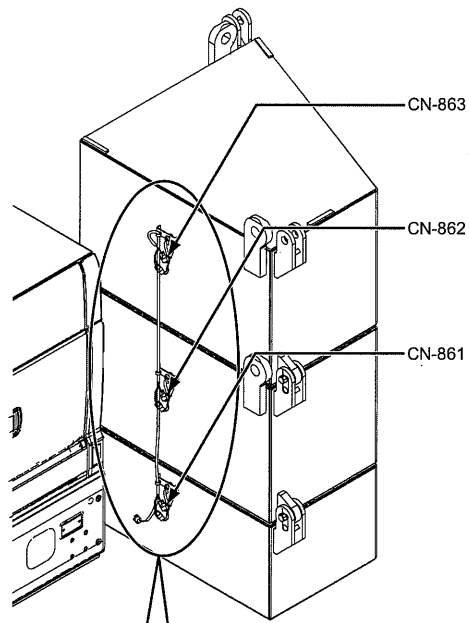

4

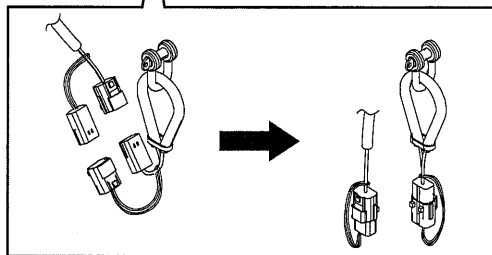

2. Open the right guard and connect the remote control cable to the receptacle.
Start the engine from the remote and set engine speed to $1,000 \text{ min}^{-1}$ (1,000 rpm).

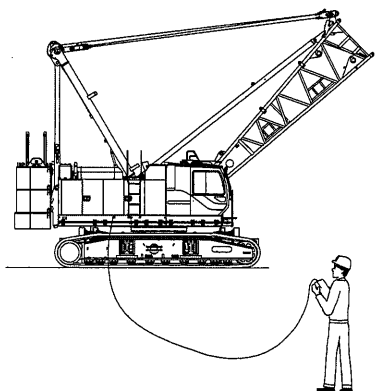

3. Fully extend the both right and left cylinders.

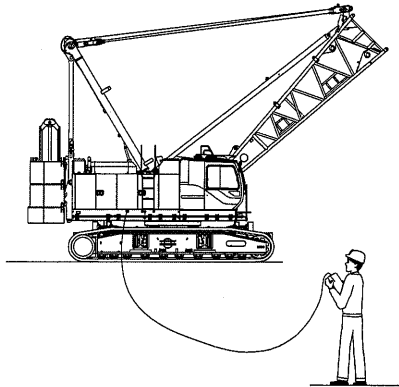
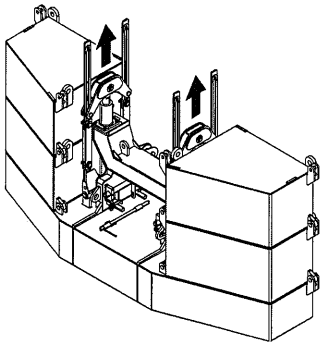

4. Go up onto WEIGHT (1) with using the ladder.
5. Pull out the lock pin and spring pin on both sides.

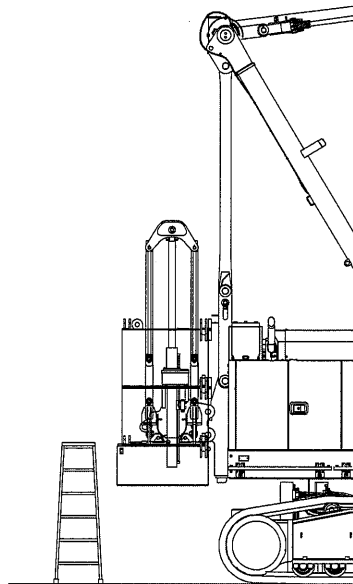
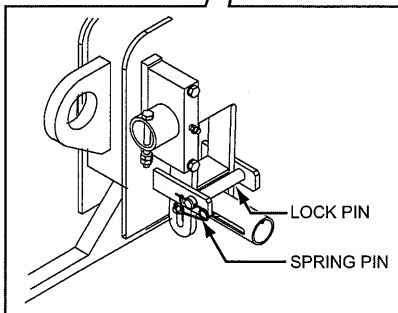
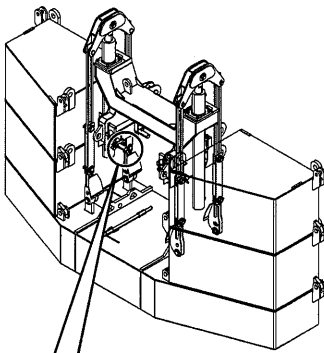

6. Pull out the weight support pin on both sides with using an extension bar.

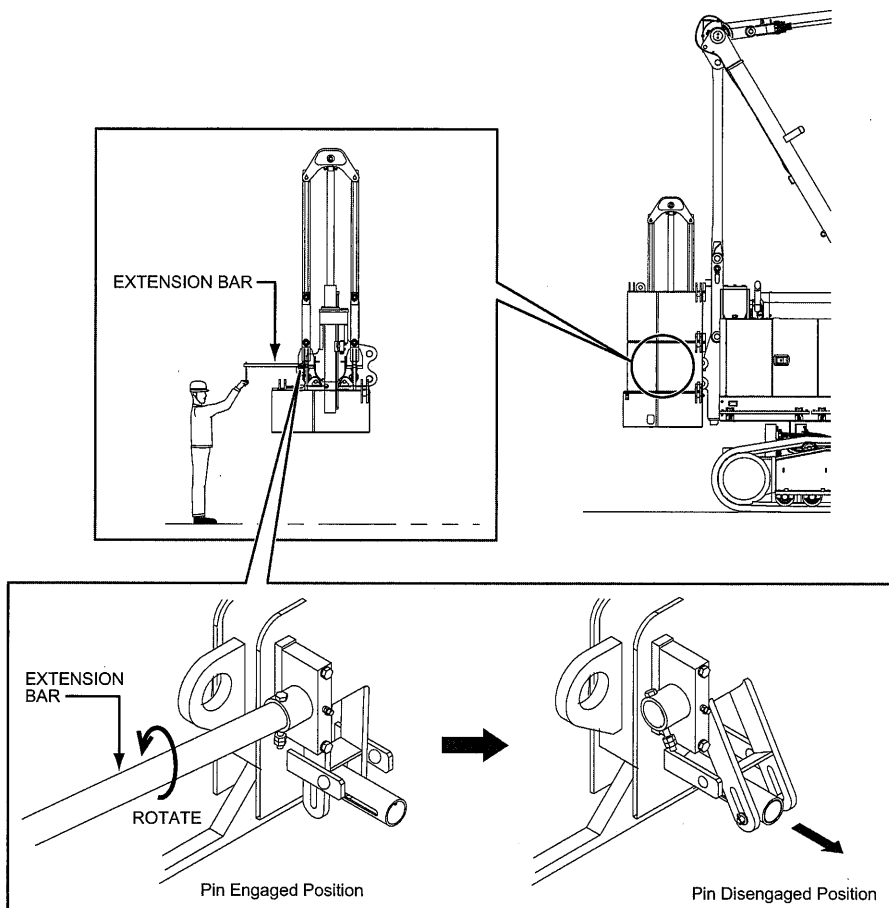

- Operate the remote control to lower the counterweight on firm and level ground.
If needed, place wood blocking.

⚠ DANGER

Slowly lift/lower the counterweight.
Failure to observe this precaution may result in a serious accident.

⚠ DANGER

When lifting/lowering the counterweights, keep the motions of the right and left cylinders even and horizontal.
Failure to observe this precaution may result in a serious accident.

⚠ CAUTION

Perform the work with engine speed 1,000 min⁻¹ (1,000 rpm) or less.
If exceeded, the cylinder speed becomes faster and excessive force could be applied on the cylinder at start or stop of motion.
This may damage the cylinder rod.

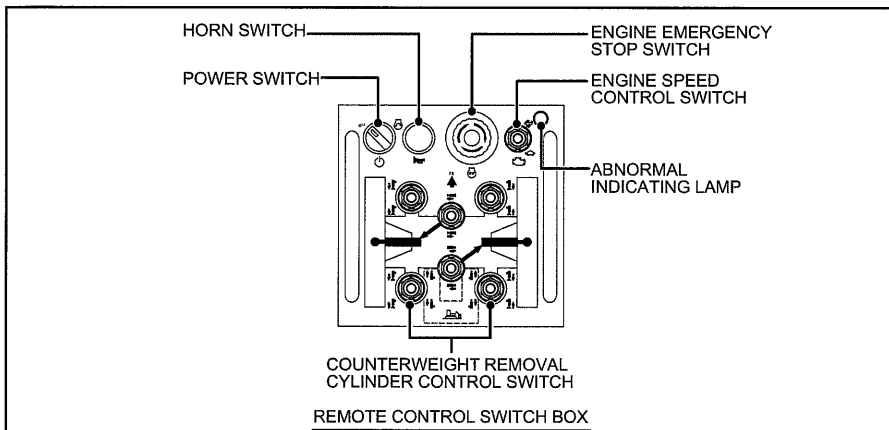
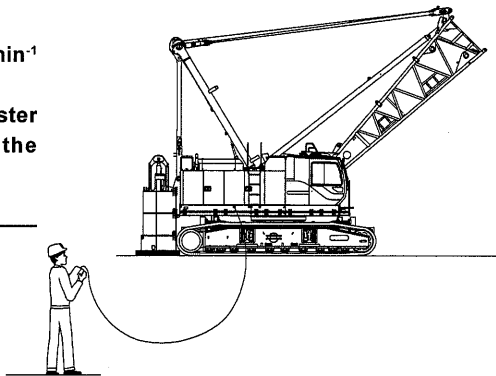

8. Disconnect the links by removing pin and lock pin.
- (A) Disconnect the links by lock pins and spring pins as shown.
 - (B) Lean the counterweight links at the base by remove pin and spring pin. (4 locations)

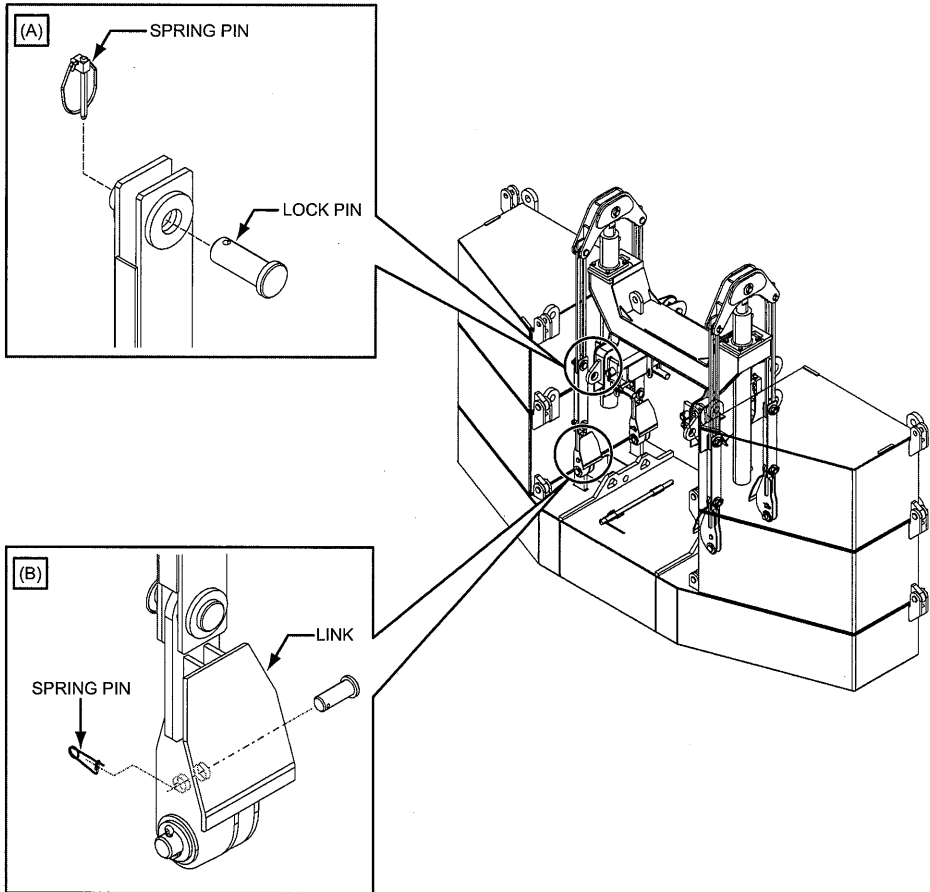

- Travel straight to keep the base machine away from the counterweights.

WARNING

Place a signal person to prevent accident from moving machinery or running ropes.
Failure to observe this precaution may result in a serious accident or injury.

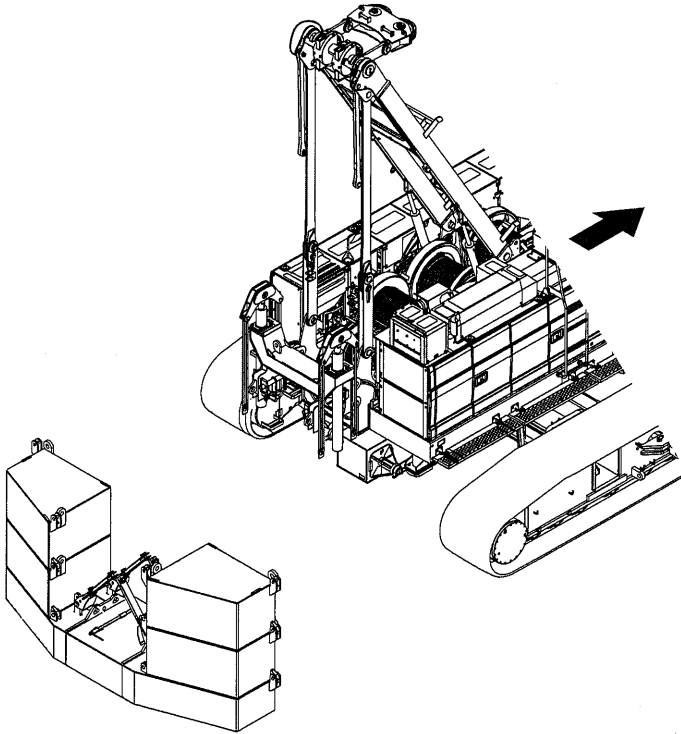

- Turn off the engine then disconnect and store the remote control switch box.

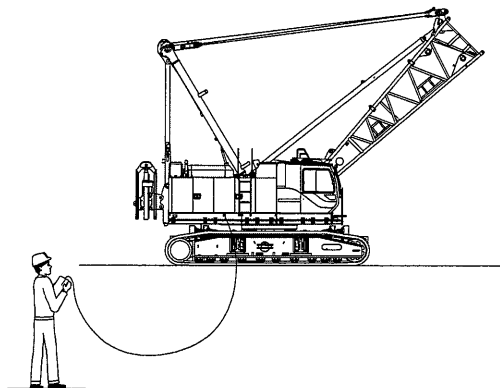

4.3.2 INSTALLATION OF THE HOOK BLOCK TO THE BOOM BASE

1. Lower the boom base to the height appropriate for reeving.
2. Install the limit switch and weight to the boom base hook.
3. Unwind the wire rope on the front drum, and reeve it through the base boom sheave, weight for the limit switch and hook block.
(2-wire rope reeving)

WARNING

Do not touch a wire rope directly with bare hands. If wire protrude, you could be injured. Working gloves are recommended.
Keep hands and clothing clear of the rotating drum and running wire rope.
Failure to observe this precaution may cause serious injury or loss of life.

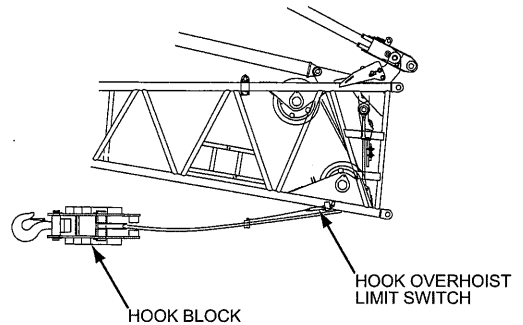

4.3.3 DISASSEMBLY OF THE COUNTERWEIGHT (USING SELF REMOVAL DEVICE)

1. Setting of LMI

When removing or attaching the counterweights, set up the LMI as the following.

Note

Unless carrying out the following steps, the machine maybe stopped by the auto-stop function and becomes impossible to work.

- (1) Press  icon on the main screen to display the menu.

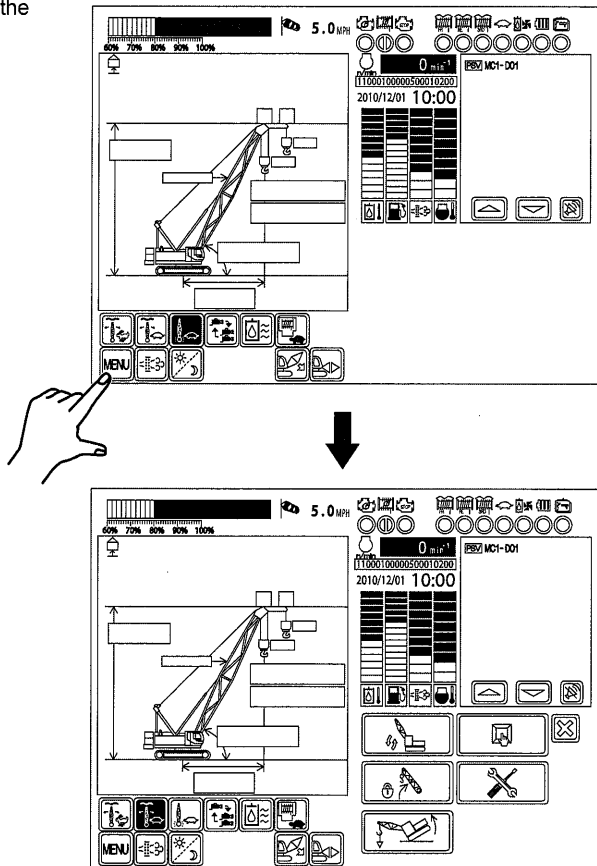

(2) On the selected screen, press  icon.

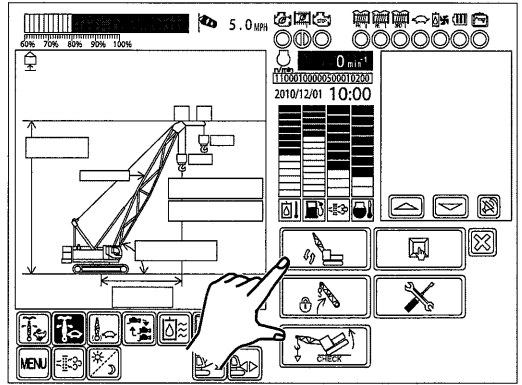

4

(3) Crane attachment select screen is displayed.
Select 10 (Self removal mode).

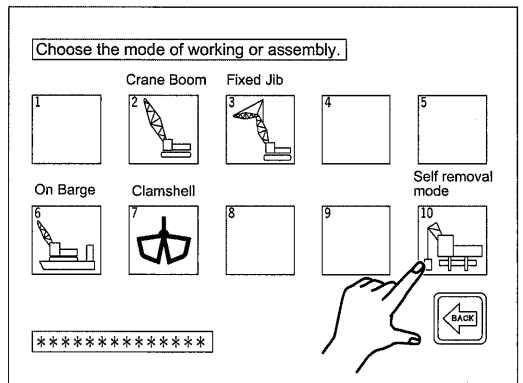

(4) Data is being loaded.

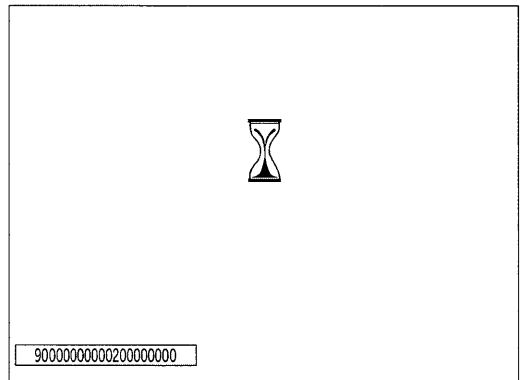

(5) After data is loaded, the result of selection is displayed.

Check if the selected items are correct.

If correct, press .

The screen returns to the main screen.

If not correct, press  to restart the input.

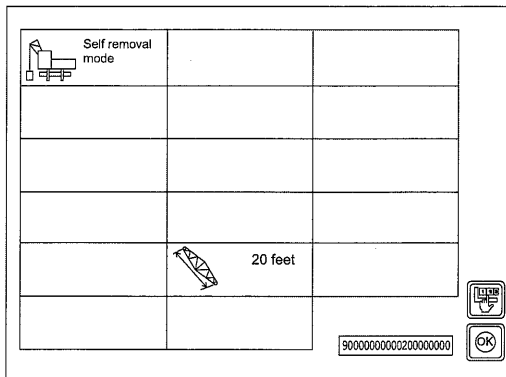

Note

In case the selection is limited to only one choice, some steps may be skipped and only the result is displayed.

2. Remove WEIGHTS (4) and (5) one by one, by disconnecting pins and lock pins.

WARNING

Do not lift more than two weights at a time.

Lifting brackets may break.

Failure to observe this precaution may result in a serious accident.

3. Remove WEIGHTS (2) and (3) in the same way as for the WEIGHTS (4) and (5).

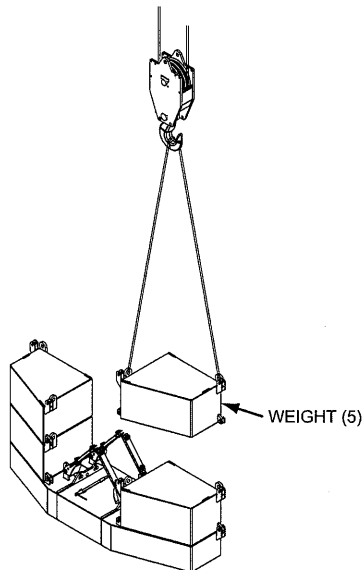
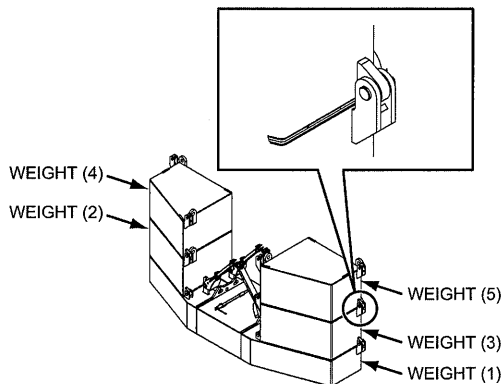

4. Lower the links by removing the pin and lock pin.

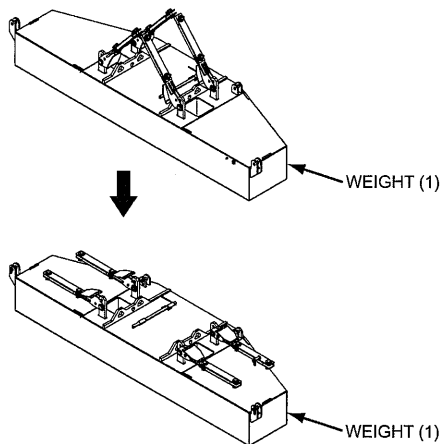

4

4.3.4 CARBODY WEIGHT REMOVAL

1. Preparation of carbody weight removal

Before removing the carbody weight, check that the machine is in the following conditions.

- The gantry is in "WORK" position.
- Main machinery is placed on firm and level ground.
- The crawler is extended to "WORK" position.
- The transfliter is set to the "WORK" condition and the floats are set to the transfliter vertical cylinder side.

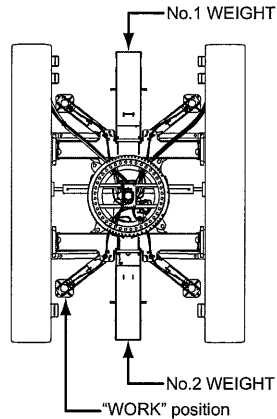

WARNING

Be extremely careful of the ratchet lever hoist operation.

Failure to observe this precaution may result in a serious injury or loss of life.

TOOL

- Attached tool set
- Assist crane (25 t capacity or larger)
(In case using an assist crane)
- Sling wire rope
(25 mm dia. × 8 m [26 ft. 2-15/16 in.] × 2)
- Shackle (10 t) × 2
(P/N : 2420Z2134D1)

EACH WEIGHT

Carbody weight	Weight
No.1 WEIGHT	3.25 t (7,165 lbs)
No.2 WEIGHT	3.25 t (7,165 lbs)

DANGER

Do not enter under the carbody weight or stand between the weight and surrounding object.

Failure to observe this precaution may result in a serious injury or loss of life.

Note

**This machine's carbody weight is composed of two pieces.
Never use the carbody weight other than specified one.**

There are two ways to remove the carbody weight. One is to use an assist crane and the other is to use the machine boom base.

Lift the carbody weight with the boom base or assist crane, and remove them by hooking them with the carbody weight brackets.

2. Removal of carbody weight

- (1) Take out the lock pin (b) and remove the carbody weight installation pin (a) on both side.
- (2) Apply sling and hook with the hook.

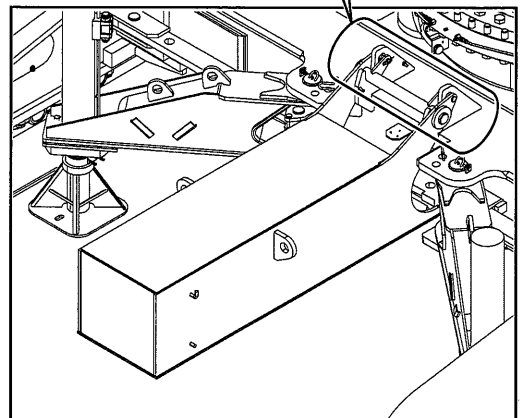
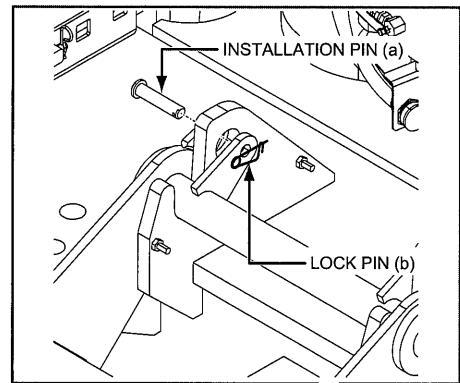

- (3) If the counterweight quantity detect unit is equipped, disconnect the detect harnesses installed on the front side counterweights from the main machinery harness.
After disconnection, put the water proof caps on both detect harnesses and the main machinery harnesses.

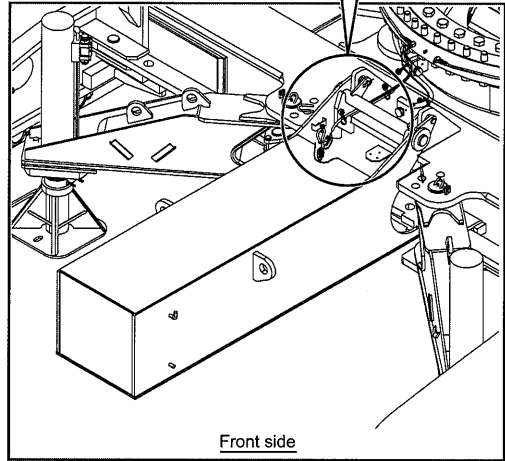
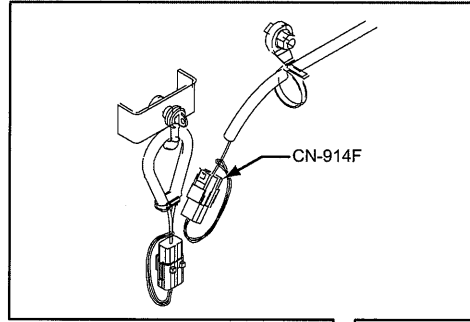

- (4) Lift up No.1 carbody weight using the boom base or assist crane and disconnect (a) area of carbody weight from (b) area of the carbody.

⚠ DANGER

Do not allow any personnel to enter under the lifting carbody weight or between the weight and the main machinery to prevent accident of falling or being caught.

Failure to observe these precautions may result in serious injuries or loss of life.

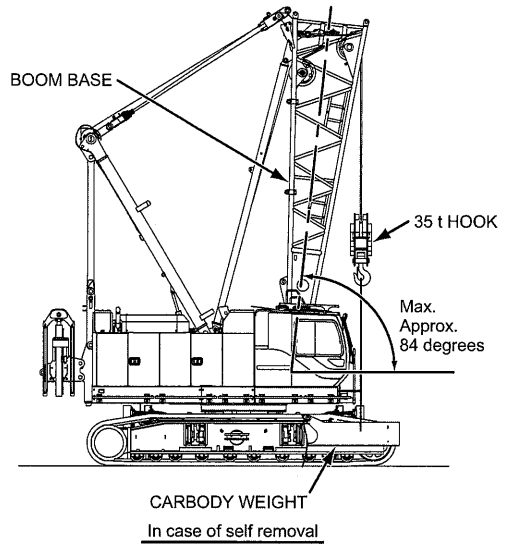

4

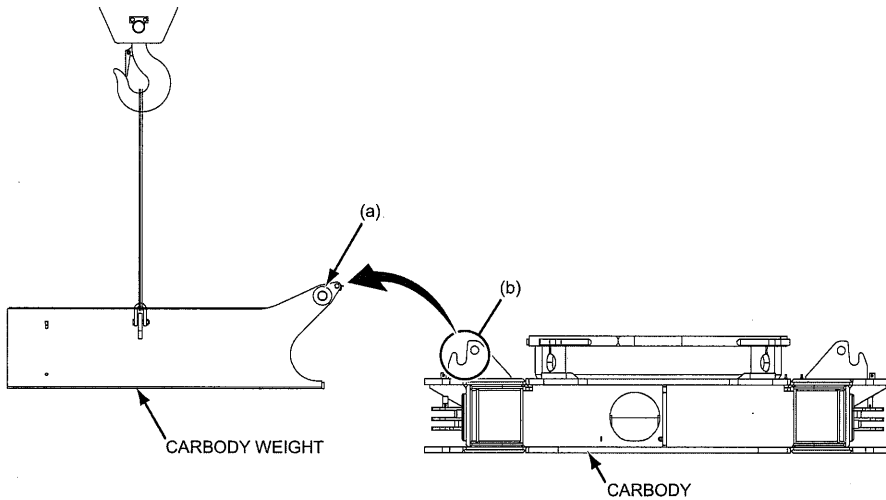

- (5) Remove No.2 carbody weight in the same manner as for the No.1 carbody weight.

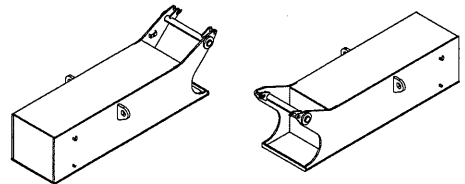

4.3.5 CRAWLER REMOVAL

1. Preparation for crawler removal (With translifter)

There are two ways of the crawler removal, one with self removal or using the boom base of the main machinery and the other using an assist crane.

Perform safer way as required.

- (1) Place the machine on the level and firm ground. The crawlers are in the work (extended) position. The counterweight must be removed.

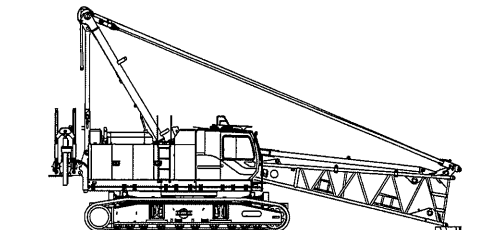

⚠ DANGER

When the translifter is to be used, set the main machinery on level and firm ground.

When the translifter is used on inclined or soft ground, a serious accident such as overturning of the main machinery or damaging the translifter may be caused.

Failure to observe this precaution may result in a serious accident.

⚠ DANGER

When the translifter is to be used, ensure to remove all the counterweights and the carbody weight.

If the translifters are used with these weights installed, a serious accident such as overturning of the main machinery or damaging the translifter may be caused.

Failure to observe this precaution may result in a serious accident.

⚠ DANGER

Crane work prohibited if transliifter is at “transport with crawler position”.

If the machine swings at this position, the machine would overturn to rear side.

Ensure to set the machine to “transliifter work position”.

Failure to observe this precaution may result in a serious injury or loss of life.

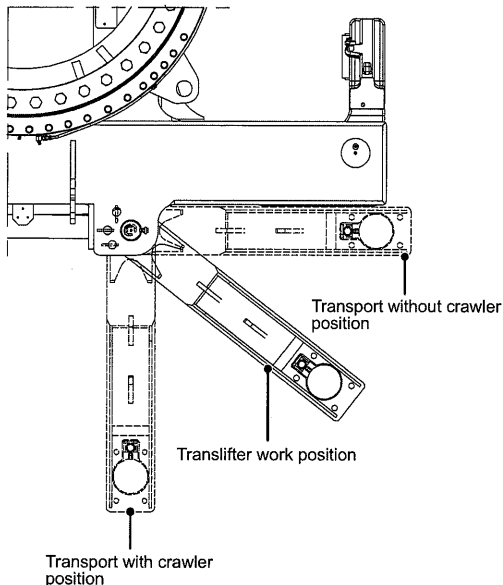

⚠ WARNING

Check if there is any abnormality on the ground condition of the float contacting area to prevent overturning of the machine.

Failure to observe this precaution may result in a serious accident.

- (2) Remove the retaining pin (j) and pull out the pin (n).

Extend the crawler ext/ret cylinder with the remote control switch and connect the crawler frame and the crawler ext/ret cylinder. Secure the crawler and cylinder with the pin (n).

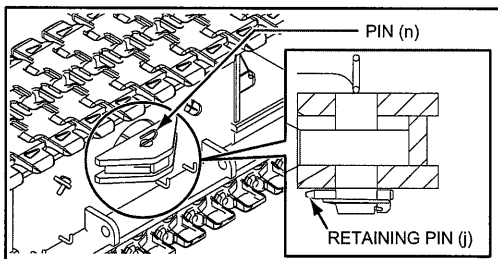

⚠ WARNING

Do not put finger or hand into pin hole.

Failure to observe this precaution may result in a serious injury.

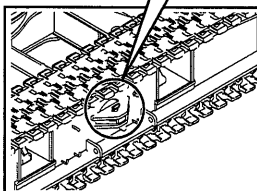

- (3) Swing the upper machinery to make the clearance between the crawler and the axle larger and then take out the adjusting shims.

Face the upper machinery toward propelling direction and set it parallel with the crawler.

Engage the swing brake and swing lock for safety.

Stop the engine.

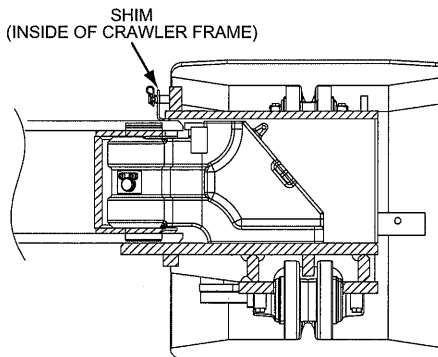

⚠ WARNING

Do not put finger or hand into the clearance between the crawler and the axle when inserting or removing the shims to prevent serious injury. Failure to observe this precaution may result in a serious injury.

- (4) When the propel motor cover bolt (r) are taken out, the cover opens.
 Disconnect the propel hydraulic hoses for both (right and left) at their quick coupler portions.
 (4 pieces on one side)
 Wipe off connectors and cover with caps.

⚠ WARNING

Do not swing when the propel hydraulic hoses are being connected or disconnected to prevent accident of being caught.

Failure to observe this precaution may result in serious injuries or loss of life.

⚠ DANGER

After the quick coupler is disconnected, wipe off the dust or dirt and put the attached dust caps to prevent them from getting dirty.

Disconnection of quick coupler must be done after the engine is stopped and inner pressure becomes lowered.

If the piping pressure is remained, disconnection would be impossible or oil would spill out.

When the coupler ring is stiff and can not move, tap on the coupler lightly with wooden hammer.

Do not hit hard with the steel hammer.

Failure to observe these precautions may result in serious injuries or loss of life.

BOLT (r) (M16)
 HEX.WRENCH
 ZT22A14000 (2 FACE WIDTH : 14 mm (1"))

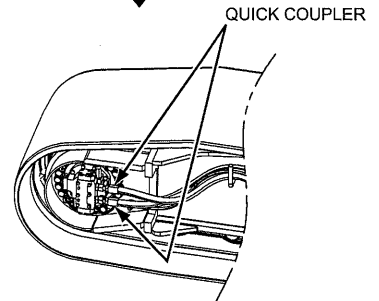
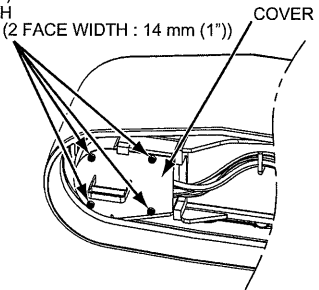

- (5) Translifter is in "WORK" position.
 Pull out the pin (a) securing the translifter at (f).
 Align the translifter fixing hole with (e) and
 secure with pin (a).

⚠ WARNING

Do not put finger or hand into pin hole.
Failure to observe this precaution may result in a serious injury.

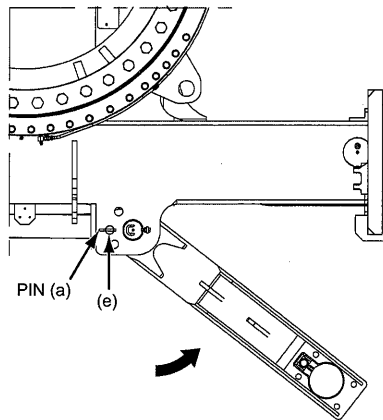
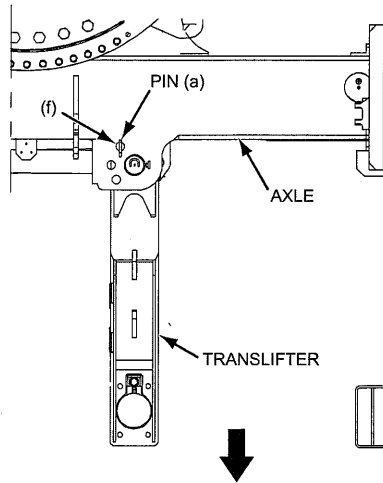

⚠ DANGER

Crane work prohibited if translifter is at "transport with crawler position".
If the machine swings at this position, the machine would overturn to rear side.
Ensure to set the machine to "translifter work position".
Failure to observe this precaution may result in a serious injury or loss of life.

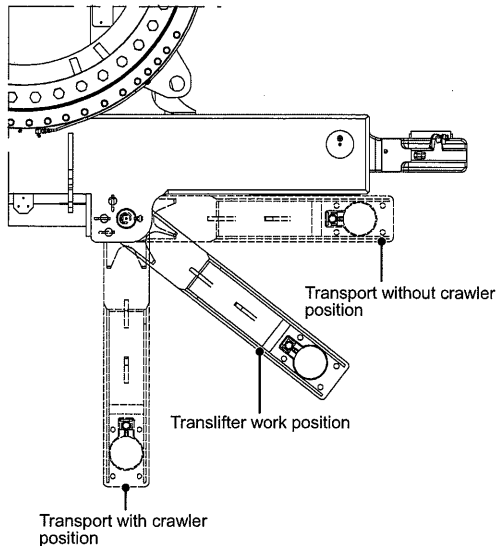

- (6) Install the float to the vertical cylinder and fix with the pin (c).

Place steel plates under the floats for safety.

CAUTION

**The float weight approx. 32 kg (72 lbs).
Handle the float with two persons to prevent injuries.**

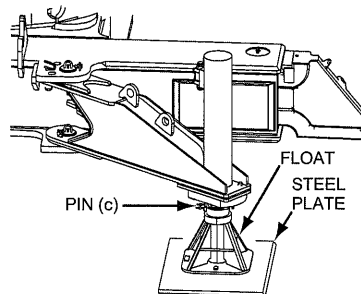

- (7) Ensure that the hydraulic hoses are connected to the vertical cylinders.

(Hydraulic hose : 4 locations 8 pieces)

CAUTION

Check that the quick coupler does not disconnect when pulled.

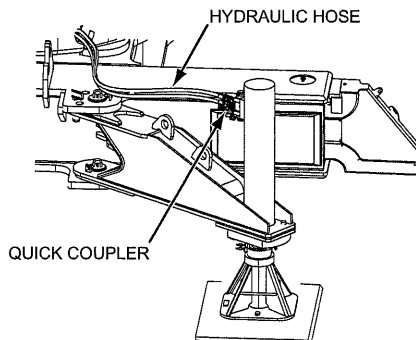

- (8) Handling the vertical cylinder control switch
 There are 4 vertical cylinder control switches.
 Pushing the switch extends the cylinder and
 push other way to retract the cylinder.
 The switch returns to neutral when hand is
 freed.

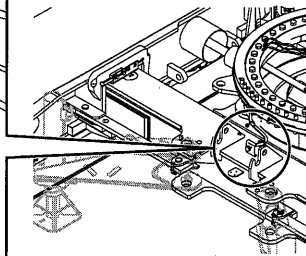
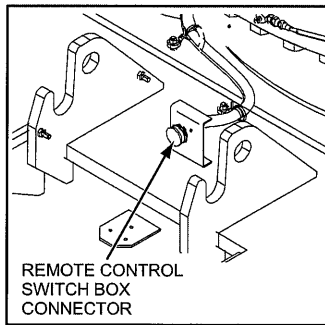
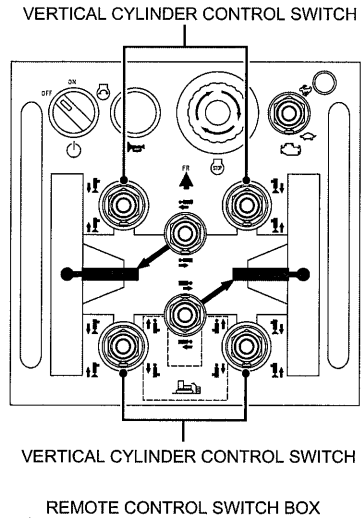

- (9) Start the engine and set the speed to LOW
 (approx. 800 min⁻¹ [800 rpm]).

By handling the vertical cylinder control switch,
 lift up the main machinery slightly to make a
 slight clearance between the shoes and roller
 and then make sure that there is no abnormality
 on the ground.

Lift up the main machinery further until the
 clearance between the lower surface of the
 main machinery and the ground becomes
 approx. 800 mm (2 ft. 8 in.).

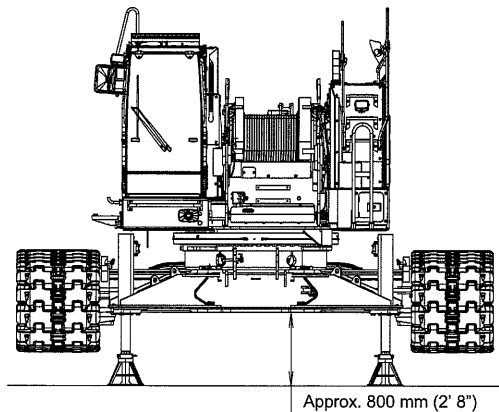

- When handling the vertical cylinders, observe the level gauge to hold the main machinery in horizontal position.
- The translifter vertical cylinder's counterforce may become 35 t (77,160 lbs) per one cylinder. Ensure to check for ground strength. Place steel plate under the floats for safety.

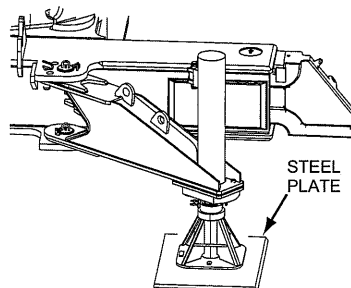

4

⚠ WARNING

Ensure to check for abnormality on the vertical cylinder contacting ground to prevent overturn of main machinery.

Failure to observe this precaution may result in a serious accident.

⚠ WARNING

Ensure to engage the swing brake and the swing lock when handling the translifter to prevent overturn of the main machinery.

Failure to observe this precaution may result in a serious accident.

2. Crawler removal

(1) Remove the pin (1a), (1b) and disconnect the crawler from the link.

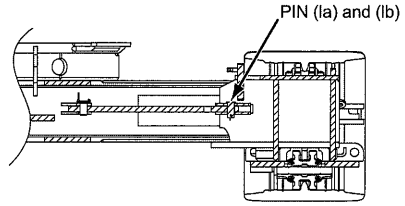

(2) Hold the left crawler, use corner protection materials so that wire does not bite into shoes. Refer to the article 8 "DIMENSION, WEIGHT OF EACH COMPONENT" as for one side crawler weight.

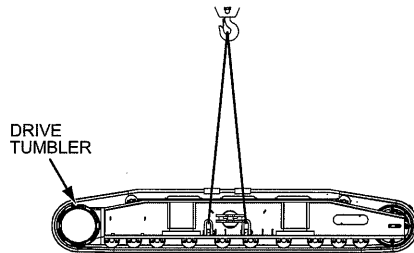
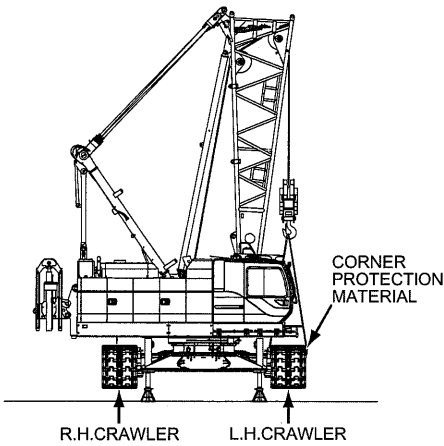

In case of using an assist crane, remove with the procedure as shown right.

CAUTION

When taking out the crawler, control the lifting crawler position with the assist crane to prevent the wire rope interfering with the deck.

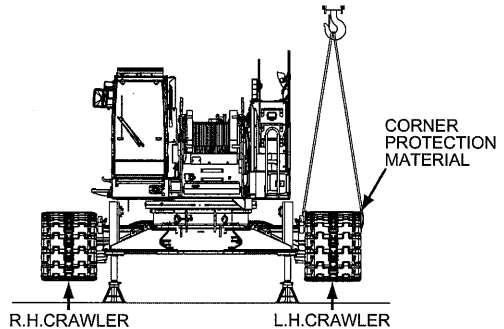

- (3) While the crawler is being held, extend the left side crawler toward outer side by controlling the left crawler extend control switch of the remote controller.

CRAWLER EXTEND CONTROL SWITCH

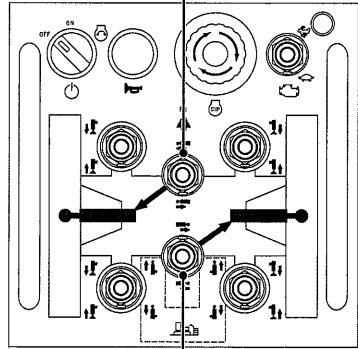

CRAWLER EXTEND CONTROL SWITCH

REMOTE CONTROL SWITCH BOX

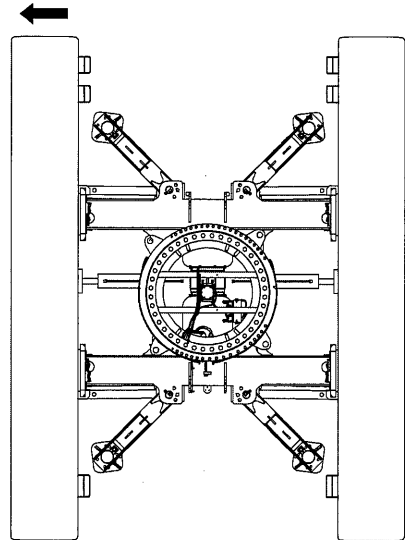

- (4) Push out the crawler until the distance between the crawler end and the axle end of the lower machinery becomes approx. 325 mm (1 ft. 1 in.) (approx. 1/3 of the axle extension).

⚠ DANGER

If the crawler comes out of the axle extension, the crawler would fall off.

Ensure that the axle extension is surely supported with the crawler.

Failure to observe this precaution may result in a serious accident.

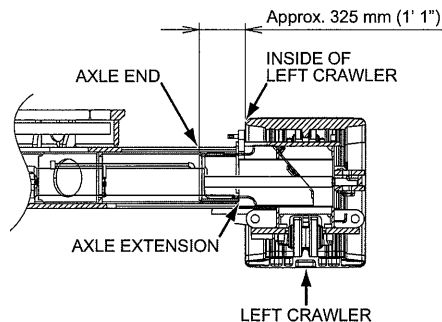

⚠ CAUTION

When pushing out the crawler with the extending cylinder, lift up the main machinery with the transliifter and keep it in horizontal position and push out so that the crawler side face keeps parallel with the main machinery.

If the crawler inclines to left or right, adjust the crawler position to parallel by handling the extension cylinder in and out or vertical cylinder up or down.

If the crawler is pushed out forcibly with the extending cylinder while being inclined, the crawler may be damaged.

- (5) Remove the pin (n) which connects the crawler frame and crawler extending cylinder.

⚠ DANGER

Do not allow any personnel to enter between the crawler and the main machinery to prevent accident of being caught.
Failure to observe this precaution may result in serious injuries or loss of life.

⚠ WARNING

Do not put finger or hand into pin hole.
Failure to observe this precaution may result in a serious injury.

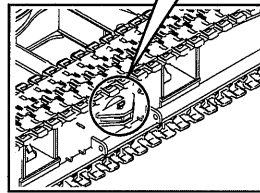
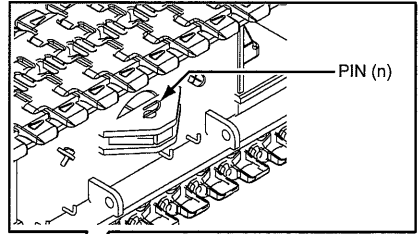

- (6) Lift up the left hand crawler with the boom base or assist crane and remove it from the axle extension.

⚠ DANGER

Do not swing over center of transliifter cylinder (90 degrees) while lifting the second crawler.
 Do not exceed 3.9 m (12 ft. 9-1/2 in.) load radius.
 Other wise the machine may overturn.
 Lift is permitted only in the area shown.
 Failure to observe this precaution may result in a serious accident.

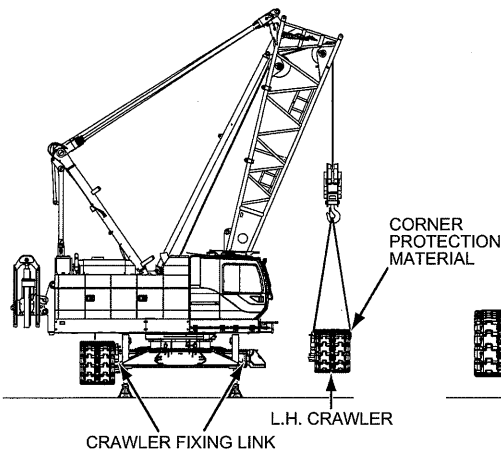
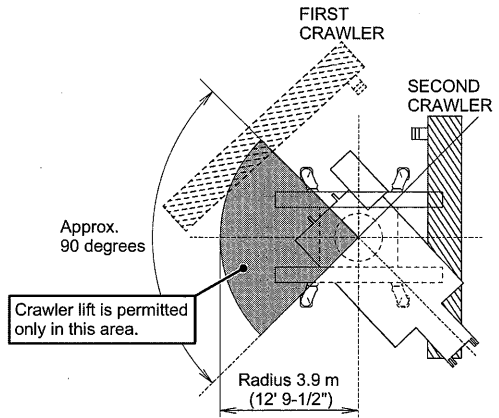

In case of self removal

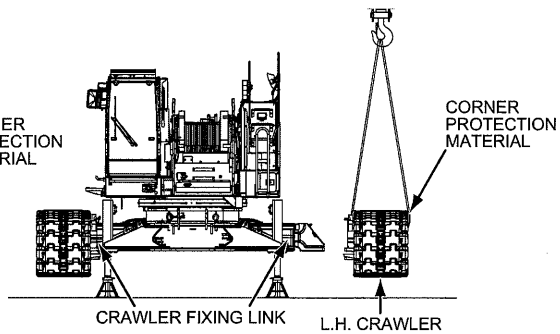

In case using an assist crane

⚠ CAUTION

When the crawler is to be pulled out from the axle, move very slowly to avoid load being applied abruptly to the assist crane.

- (7) Remove the right hand crawler in the same way as the left hand crawler.

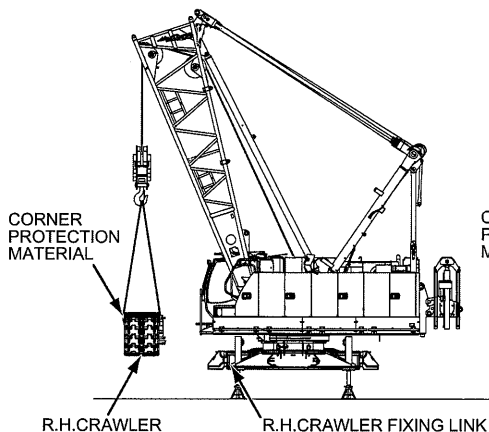

In case of self removal

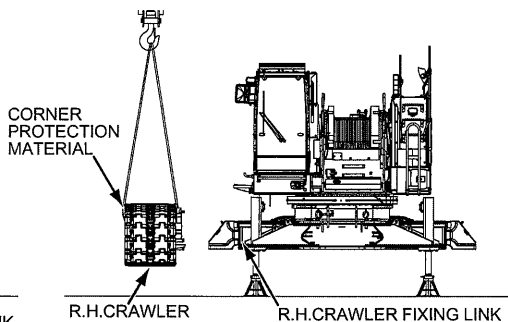

In case using an assist crane

4

⚠ DANGER

Do not swing the upper machinery when only one side of the crawler is attached to avoid overturn of the machinery.

Failure to observe this precaution may result in a serious accident.

⚠ CAUTION

When taking out the crawler, control the lifting crawler position with the assist crane to prevent the wire rope interfering with the deck.

- (8) Place the removed crawler onto the trailer.
- (9) Retract the crawler extend/retract cylinder fully.

⚠ DANGER

Do not exceed 3.9 m (12 ft. 9-1/2 in.) load radius. Otherwise the machine may tip over. Failure to observe this precaution may result in a serious injury or loss of life.

⚠ DANGER

Do not operate the machine abruptly when the machine is standing with translifter. Failure to observe this precaution may result in a serious injury or loss of life.

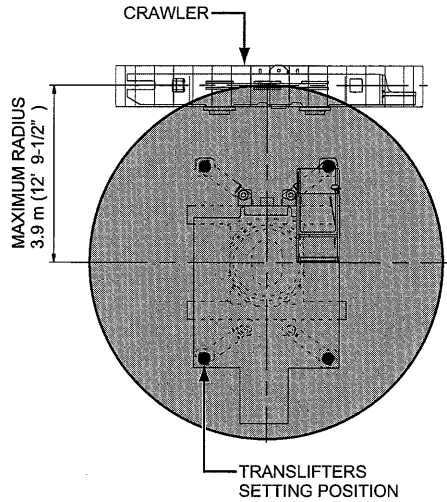

4.3.6 MAIN MACHINERY LOADING ONTO TRAILER

Check the following points before starting the work.

- Place
Ground must be firm and level.
The ground has been improved and steel plates have been placed.
- Meeting for work procedure and safety
Prior to work, a meeting must be held to review the work procedure and safety with all personnel and confirm of each personnel's roles and responsibilities.
- Pre-work inspection
Conduct the pre-work inspection.
- Transporting the main machinery on a trailer may require permit(s) issued by the related authority(ies).
Refer to the article 8 "DIMENSION, WEIGHT OF EACH COMPONENT".
Prepare proper trailer for the machinery weight and size.

4

 DANGER

Do not raise the boom to higher than 10 degrees angle when loading into trailer.

Main machinery may overturn backward.

Failure to observe this precaution may result in a serious injury or loss of life.

1. Start the engine and set the speed to LOW (approx. 800 min⁻¹ [800 rpm]).
Lift the main machinery to make the ground clearance of the axle lower face 500 mm (1 ft. 8 in.) with the cylinders.
-

 **DANGER**

When the translifter is to be used, set the main machinery on level and firm ground.

When the translifter is used on inclined or soft ground, a serious accident such as overturning of the main machinery or damaging the translifter may be caused.

Failure to observe this precaution may result in a serious accident.

 **DANGER**

When the translifter is to be used, ensure to remove all the counterweights and the carbody weight.

If the translifters are used with these weights installed, a serious accident such as overturning of the main machinery or damaging the translifter may be caused.

Failure to observe this precaution may result in a serious accident.

⚠ DANGER

Crane work prohibited if translifter is at “transport with crawler position”.

If the machine swings at this position, the machine would overturn to rear side.

Ensure to set the machine to “translifter work position”.

Failure to observe this precaution may result in a serious injury or loss of life.

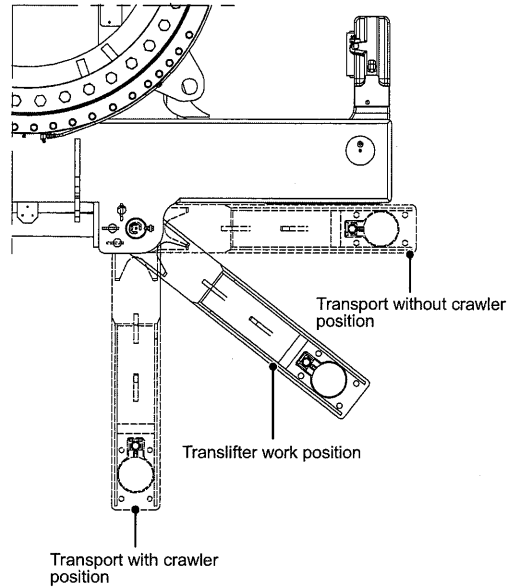

4

⚠ WARNING

Check if there is any abnormality on the ground condition of the float contacting area to prevent overturning of the machine.

Failure to observe this precaution may result in a serious accident.

⚠ WARNING

To prevent overturning of the main machinery, ensure to engage the swing brake and swing lock when the translifter is handled.

Failure to observe this precaution may result in a serious accident.

⚠ WARNING

Do not put finger or hand into pin hole.

Failure to observe this precaution may result in a serious injury.

CAUTION

When the hydraulic pressure source hoses are connected on the translifter control valve and the front block of upper frame, take extra care so that these hoses are not caught with the lower machinery or translifter.

2. Swing the upper machinery so that it becomes parallel with the axle and engage the swing brake and insert the swing lock pin and turn the function lock lever to "LOCK (UP)" position.

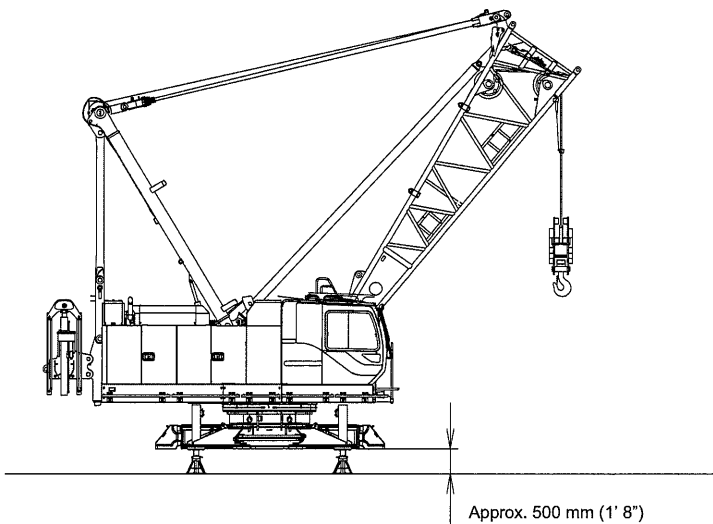

3. Remove the bracket (t) which has been inserted to the foot are of the axle extension.

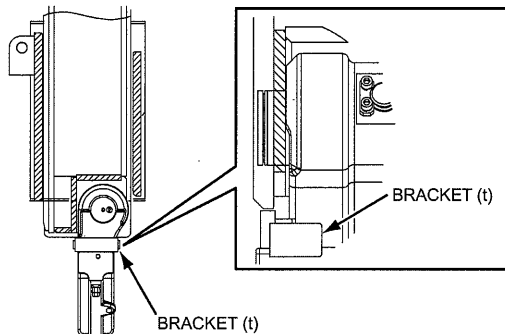

4. Rotate all four axle extensions for 90 degrees toward the frame to make them right angle with axles.

⚠ DANGER

When handling the translifter, make sure that all the counterweight are removed to prevent overturn of the main machinery.

⚠ CAUTION

In case that the translifter control valve and the hydraulic source hose in the swing frame front block are connected, take extra care not to make translifter pick up the hose during swing movement.

⚠ CAUTION

Take extra care that the each hose of propel, high low speed select or drain hose would not be jammed or run over during loading into the trailer.

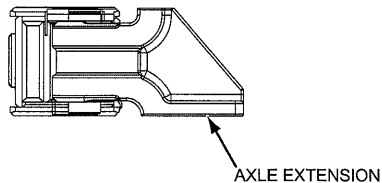
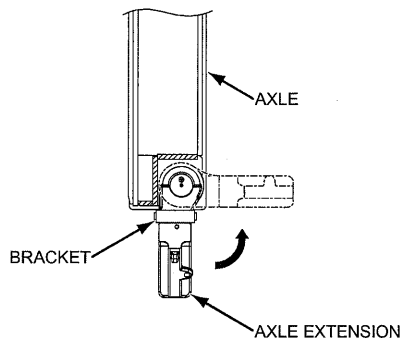

5. Lift up the main machinery to the height so that the trailer bed can drive in under the machinery.
Ground clearance of the main machinery :
1,093 mm (3 ft. 7 in.)

⚠ WARNING

Ensure that there is no abnormality on the float contacting ground before lifting up to prevent overturn of the main machinery.
Failure to observe this precaution may result in a serious accident.

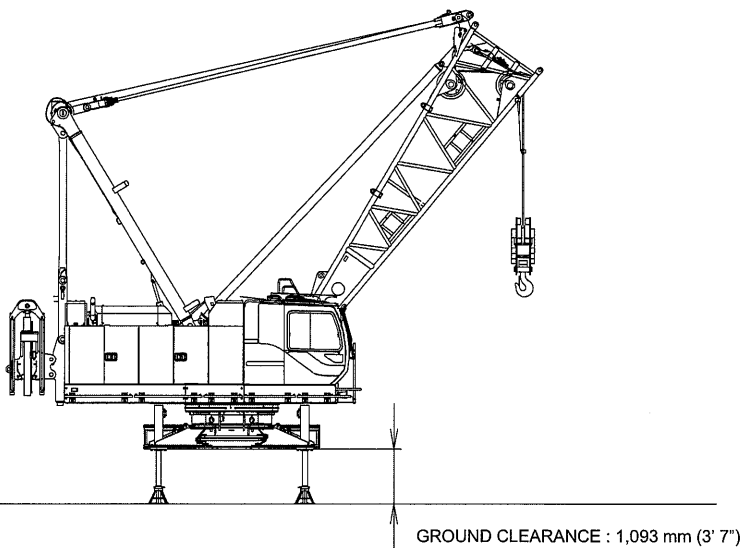

6. Drive the trailer backward to park under the main machinery.

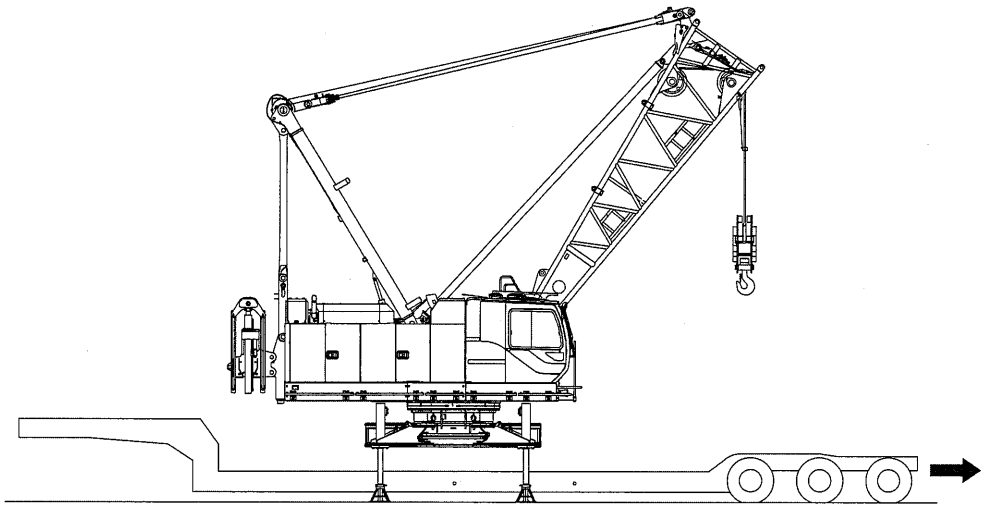

7. Make sure that the trailer loading deck comes just under the lower machinery.
8. Set the wood blocking (thicker than 120 mm [5 in.]) under the lower machinery so that the machine can be settled on them.

⚠ WARNING

Do not swing with the vertical cylinders retracted to avoid turn-over of the trailer.

Failure to observe this precaution may result in a serious accident.

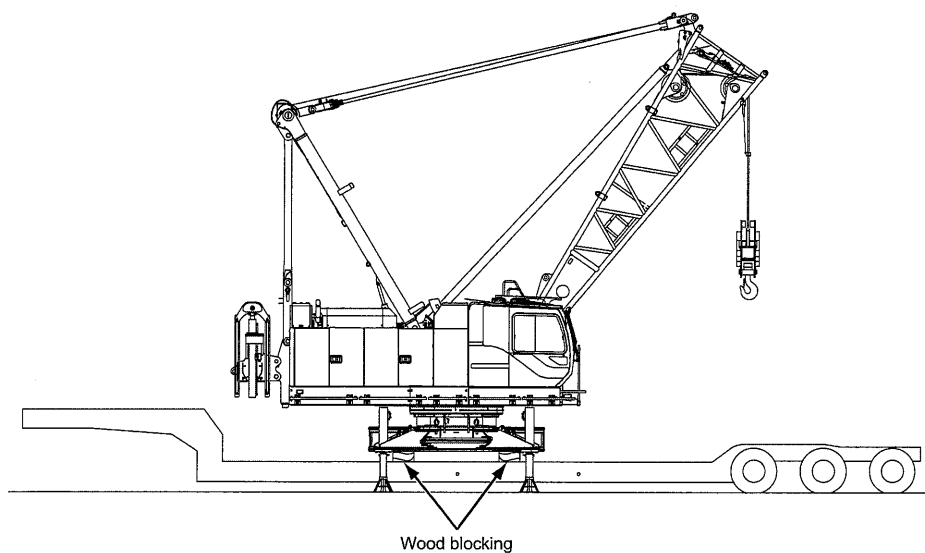

9. Lowering boom base

Slowly lower the boom base, and place the tip of it onto the trailer.

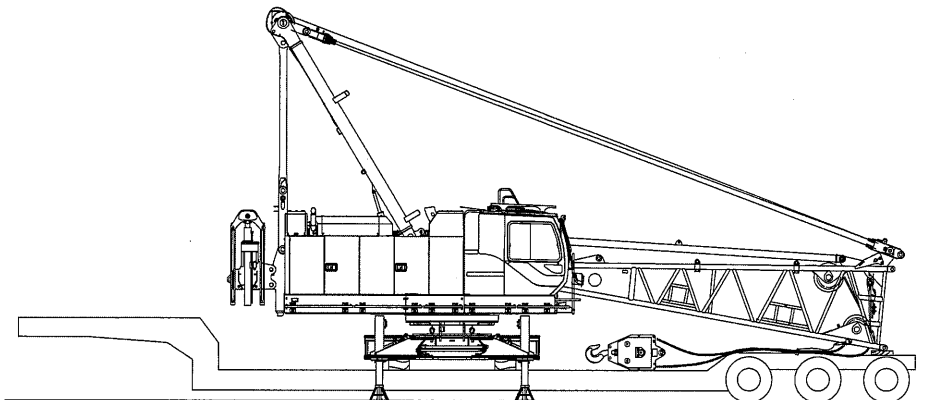

4

10. Lowering the gantry

⚠ DANGER

Do not enter under or inside of the gantry or under the boom.

Failure to observe this precaution may result in a serious injury or loss of life.

⚠ WARNING

Do not touch wire rope or sheave when the rope is running.

Failure to observe this precaution may result in a serious injury or loss of life.

- (1) Take out the spring pin and pull out the pin (y) from the gantry at right and left sides and stow them to the holders.

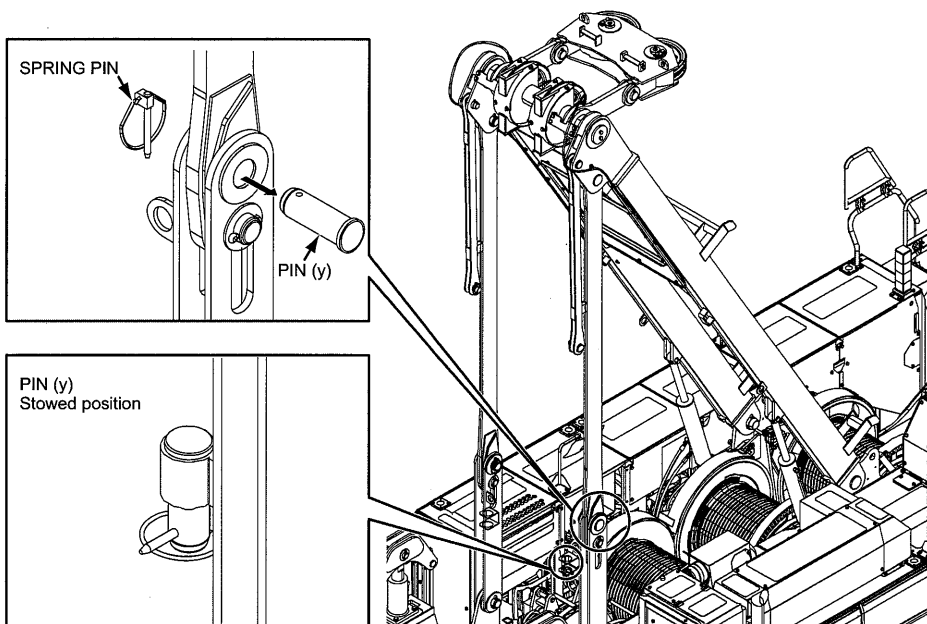

- (2) Pull out the pin (w) from the travel kit and remove the travel kit from the stopper.

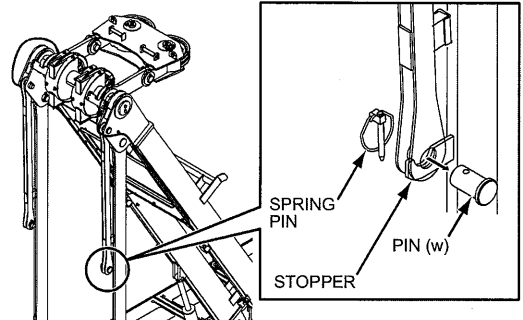

- (3) Start the engine and set the speed to 1,000 min⁻¹ (1,000 rpm).
 (4) Turning the gantry control switch to "DOWN" side (inward) to lower the gantry.
 At this time, pay out the boom hoist rope to prevent the boom from becoming lifted.

⚠ DANGER

Do not enter under or inside of the gantry (or mast).

Failure to observe this precaution may result in a serious injury or loss of life.

⚠ CAUTION

Never raise the gantry by winging the boom hoist wire rope or using the assist crane.

Use the gantry cylinders.

Otherwise the gantry raise cylinders may be damaged.

⚠ CAUTION

Before operating the gantry control switch, check that there is no person under or near the gantry and sound the horn.

During work or raising the boom hoist, do not operate the gantry control switch if the boom hoist wire rope is tensioned.

Failure to observe these precautions may result in a serious accident.

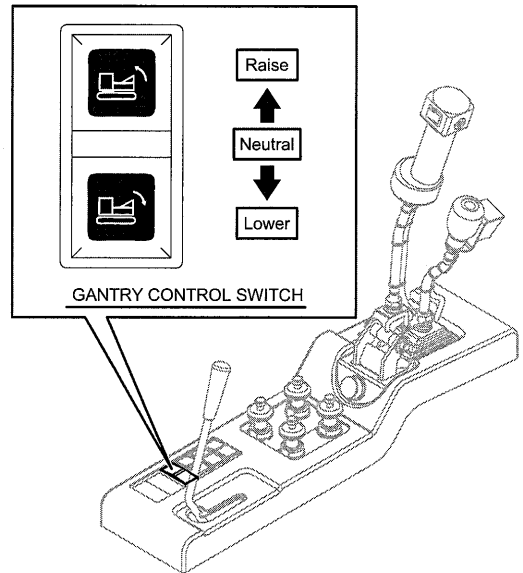

- (5) Secure the travel kit links on both right and left side with pin (w) and retain with the spring pin.

⚠ DANGER

Ensure to connect the travel kit as figure shown, otherwise the boom may fall down when the gantry is in low position. Failure to observe this precaution may result in a serious injury or loss of life.

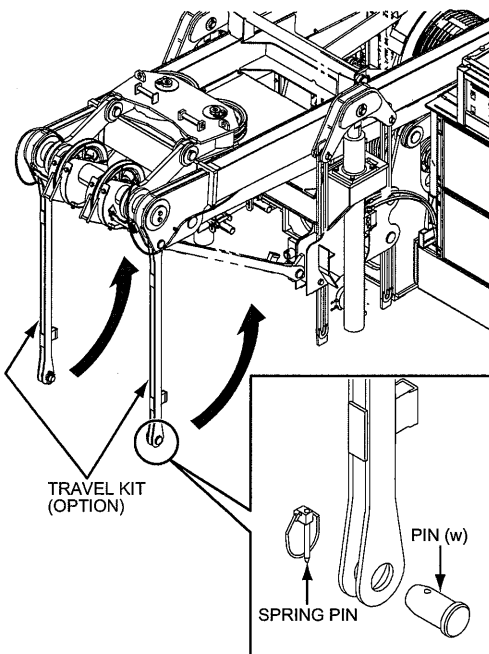

11. Stop the engine and stow the transifter as per the following procedure.
 - (1) Engage the swing brake and keep the swing lock pin inserted and set the function lock lever to the "LOCK (UPPER)" position.
 - (2) Disconnect the hydraulic hose from the vertical cylinder.
(Hydraulic hose 4 locations total 8 pieces)

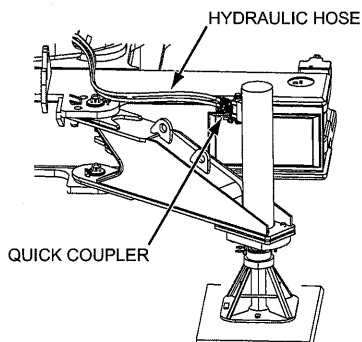

- (3) Remove the pin (c) as shown right and remove the float from the vertical cylinder.
Load the float on the trailer and secure them to prevent falling off the trailer.

CAUTION

**The float weighs approx. 32 kg (72 lbs).
Handle the float with two persons to prevent injuries.**

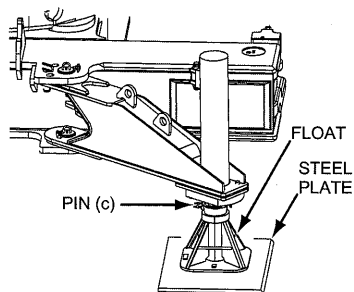

If needed, use remote control switch box to retract cylinders.

- (4) Pull out the pin (a) securing the translifter at (e) area.
Align the translifter fixing hole with (d) and secure with pin (a).

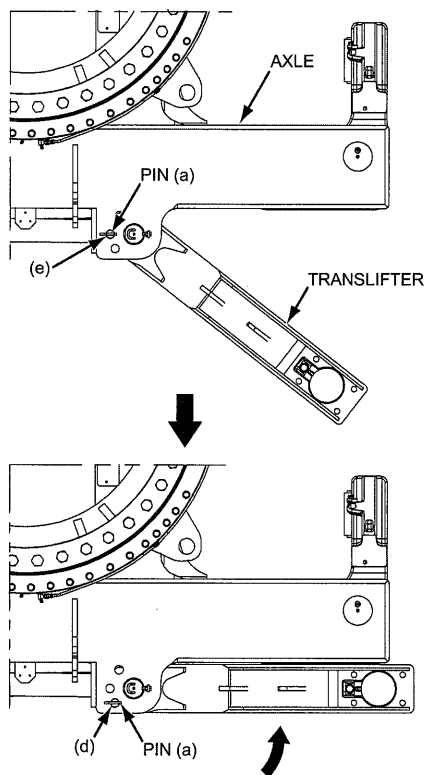

12. Secure down the axle to the trailer with the wire rope or chain to prevent cargo shifting during transportation.

CAUTION

Take extra care that the each hose of propel, high/low speed select or drain hose would not be jammed or run over during loading into the trailer.

Refer to the article 8 "DIMENSION, WEIGHT OF EACH COMPONENT" for the weight and dimension during disassembly work.

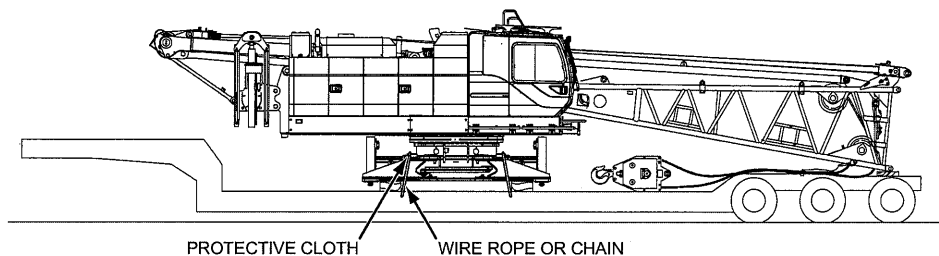

13. Close and lock the door cab, window, door and guard then stow the cab entrance step.
14. In case of transportation with the boom base removed, refer to the next page.

4.3.7 STOWING CAB STEP

Stow the cab step by the following procedure for transportation.

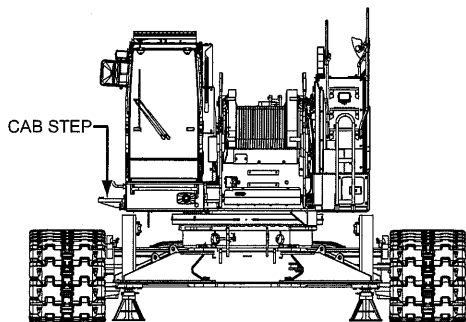

4

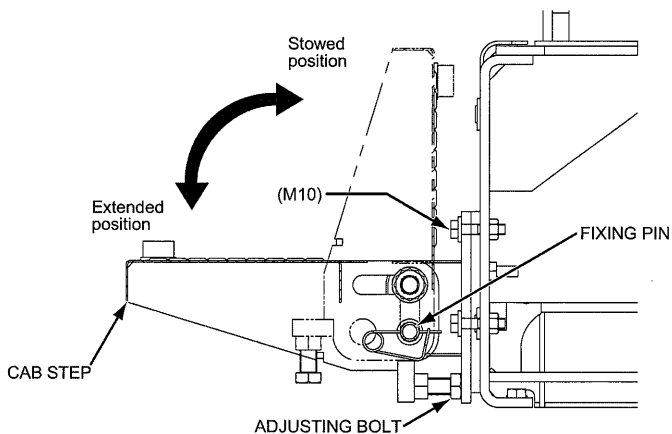

1. Remove the fixing pin and rotate the cab step to stowed position.
2. Secure a side of each step with a fixing pin.

Note

To make transportation width to 2,990 mm (9 ft. 10 in.), remove all side steps completely.

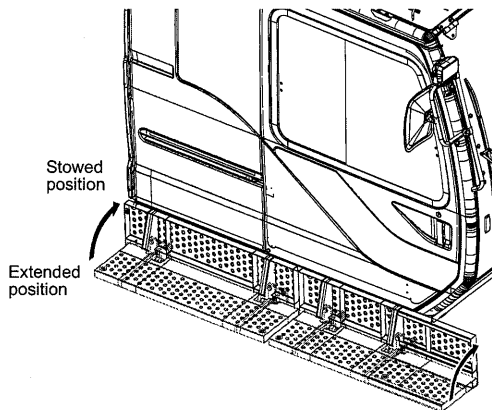

4.4 TRANSPORTATION

In case of transportation of the machinery or attachment with trailer/truck, there will be various combinations in different weight, size or type of trailer/truck and the fleet configurations.

Carefully review the dimensions and weight of components for a safe transportation.

There will be limitations on the size and weight due to regulations. Submit the necessary document to obtain the permit(s) from the respective authority(ies).

For the details, refer to the applicable traffic regulations.

Refer to the article 8 "DIMENSION, WEIGHT OF EACH COMPONENT".



Do not exceed weight limit or dimension limit.

Do not perform unreasonable transportation since it may lead to accident involving person or property.

Failure to observe these precautions may result in serious injuries or loss of life.

- Make sure that the swing lock, each drum lock is engaged.
- Make sure that each control lever, switch is in neutral or at stop position.
- Make sure that the room lights or outside lights are off and the engine is stopped.
- Make sure that the steps, mirrors, hand rails or any protruding object are stowed or removed.
- Place the wood blocking between the carbody or axle extension and the trailer bed to prevent the machinery from slipping.
- Secure down the load onto the trailer/truck firmly with proper gears (tie downs and binder chains) to prevent them from shifting during transportation.
- In case of transportation with the crawler removed, do not secure by the axle extension. Secure at the axle.

4.4.1 CAUTION WHEN TRANSPORTING THE BASE MACHINE

When transporting the base machine, fix the counterweight removal links with the chain and secure the gantry with the travel kit.

⚠ DANGER

Do not raise the boom to higher than 10 degrees angle when loading into trailer.

Main machinery may overturn backward.

Failure to observe this precaution may result in serious injury or loss of life.

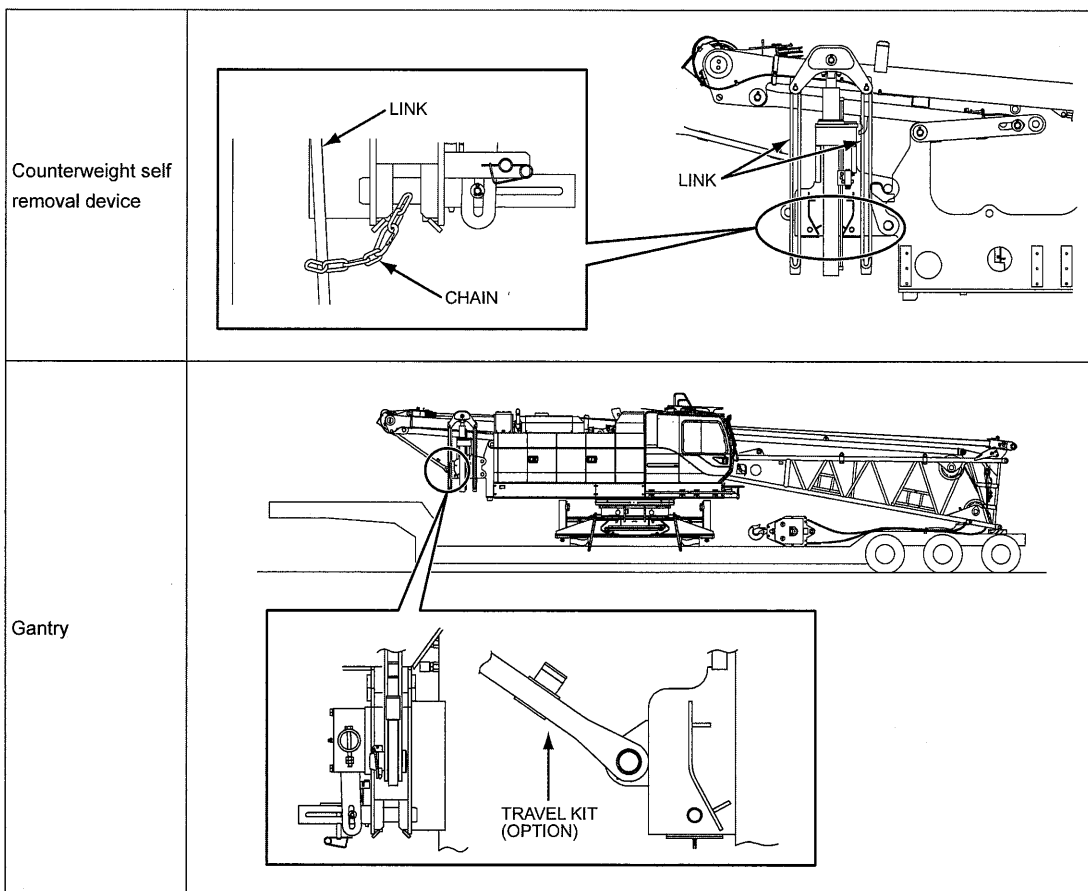

4.5 LIFTING OF WHOLE MAIN MACHINERY

Check the following points before starting actual work :

1. Location
 - (1) Ground must be level and firm, with steel plates used if necessary.
 - (2) There is enough swing space for assist crane and access space for trailer and truck.
2. Confirmation of work procedure and safety practice.

Prior to assembly work, all personnel concerned must confirm work procedure, safety practice, and understand their individual role and responsibility.
3. Machine inspection.

Basic machine must be inspected for proper operating condition before beginning work.

4.5.1 UPPER STRUCTURE (WITH CARBODY) LIFTING PROCEDURES

1. Installation

- (1) Reeve the lifting ropes around the boom foot pins and the gantry tension member pins with the shackle.

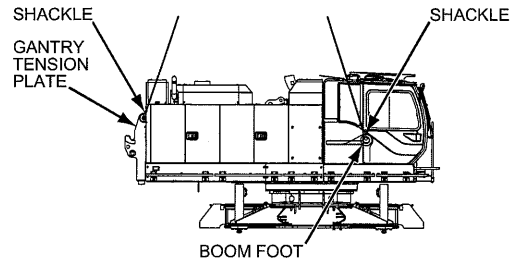

CAUTION

Using a short wire rope or lifting with positions other than specified, may cause damages to the machine.

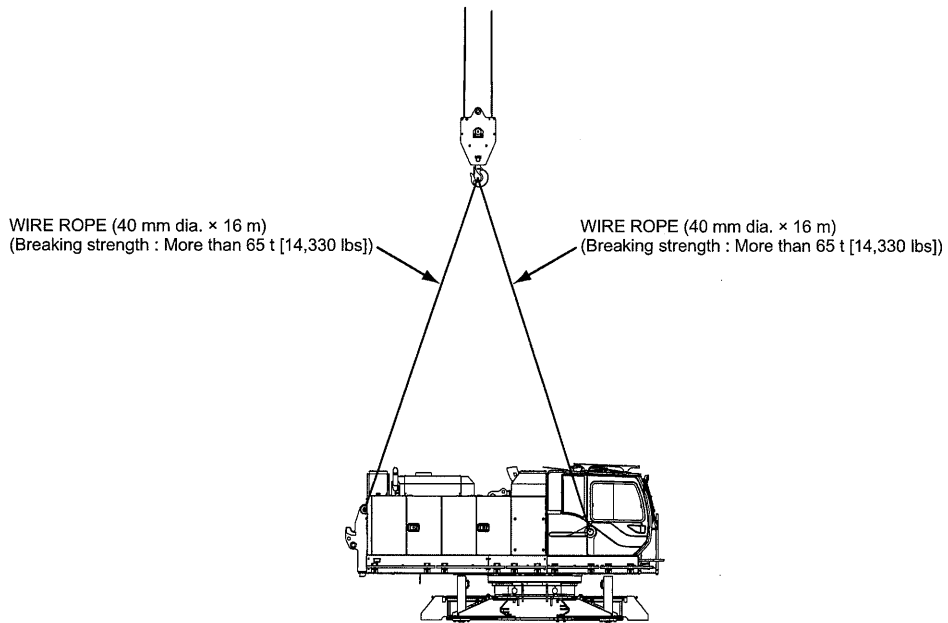

4.5.2 LOADING/UNLOADING THE MACHINE FROM/ONTO A TRAILER

1. Loading onto a trailer
 - (1) Position a trailer under the lifted machine.
Lower the machine onto the trailer.
 - (2) Set the wood blocking (thicker than 120 mm)
under the lower machinery so that the machine
can be settled on them.



**Do not swing the machine in this condition.
Failure to observe this precaution may result in a
serious accident.**

- (3) Secure the machine to the trailer to prevent it
from being dropped.

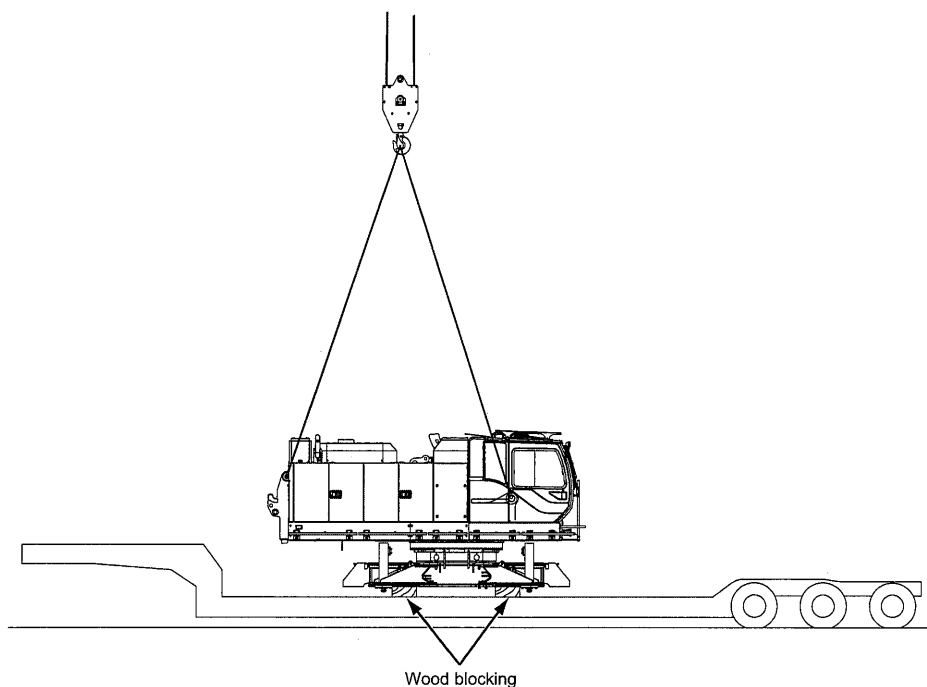

2. Unloading from a trailer

Unload the machine from a trailer, refer to the
article "4.2.1 UNLOADING MAIN MACHINERY
FROM TRAILER".

4.5.3 INSTALLATION OF CRAWLER

Install the crawlers, refer to the article "4.2.2 CRAWLER INSTALLATION".

4.5.4 INSTALLATION OF GANTRY TO SWING FRAME

1. Reeve through the ropes around the gantry peak pin, and lift the gantry with the assist crane.

⚠ DANGER

Only use ropes and slings in good condition for lifting gantry.

Do not use the hook without safety latch, or use damaged slings to lift the gantry.

Failure to observe this caution may lead to the sudden fall of the gantry.

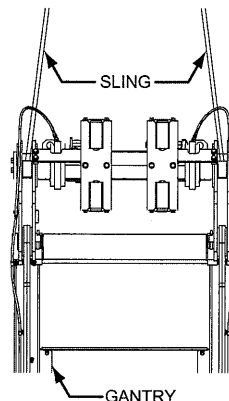

2. Install the compression foot of the gantry to the base machine.
Install pin and split pin on right and left side.

⚠ DANGER

Do not stand under the gantry to avoid accident of being caught due to sudden drop of gantry.

Failure to observe this precaution may result in a serious injury or loss of life.

⚠ WARNING

Do not put finger or hand into pin hole.

Failure to observe this precaution may result in a serious injury.

Note

Apply grease to the pin hole.

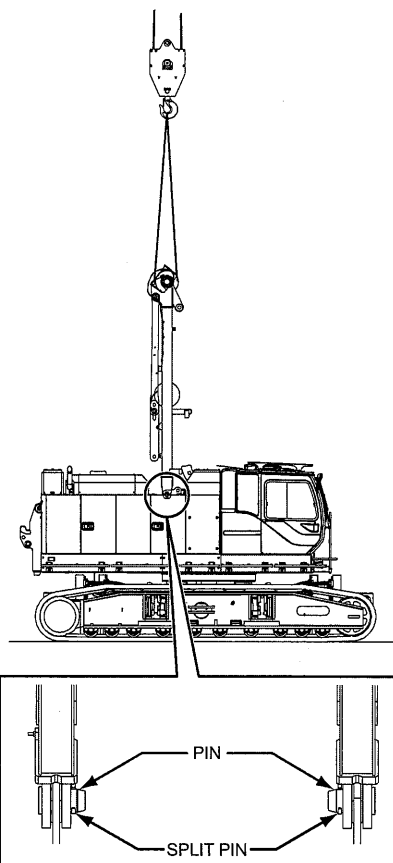

3. Slowly lower the gantry toward the rear of the base machine, and connect the tension member to the frame plate with the pins and split pins on both side.

WARNING

Do not stand under the gantry to avoid being caught if the gantry suddenly drops.
Failure to observe this precaution may result in a serious injury or loss of life.

WARNING

Do not put finger or hand into pin hole.
Failure to observe this precaution may result in a serious injury.

Note

Apply grease to the pin hole.

4. Retract the gantry cylinder by operating the control switch.

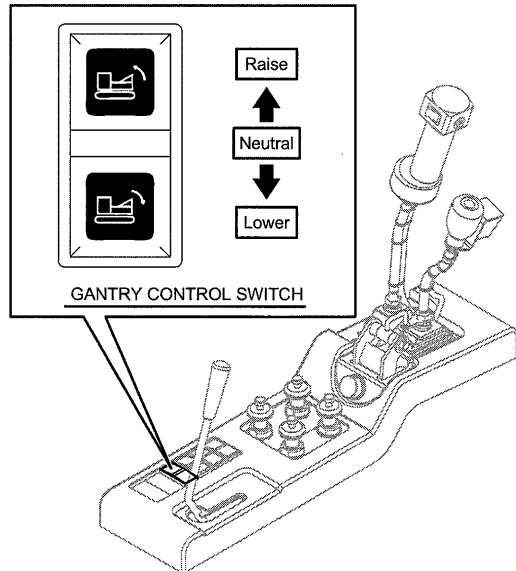
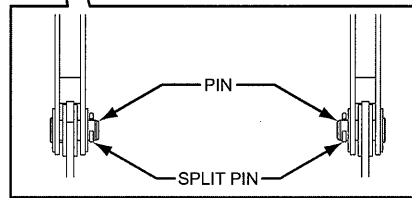
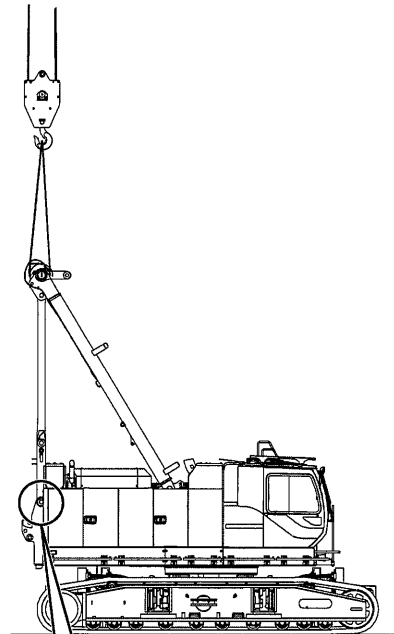

5. Lower the gantry backward fully.

WARNING

**Do not stand under the gantry to avoid being caught if the gantry suddenly drops.
Failure to observe this precaution may result in a serious injury or loss of life.**

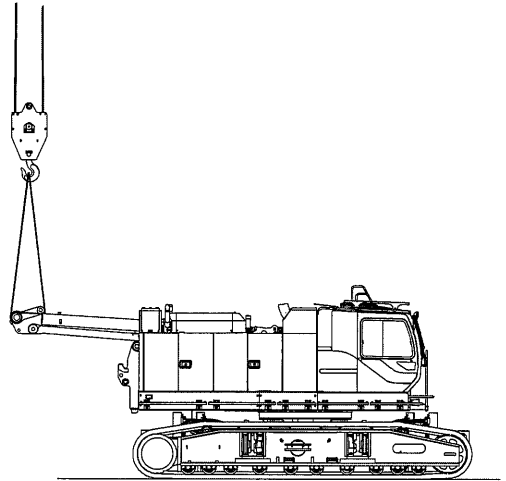

4

6. Connect the gantry cylinders to the compression members with pin and split pin on both side.

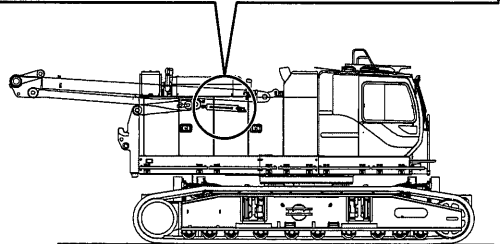
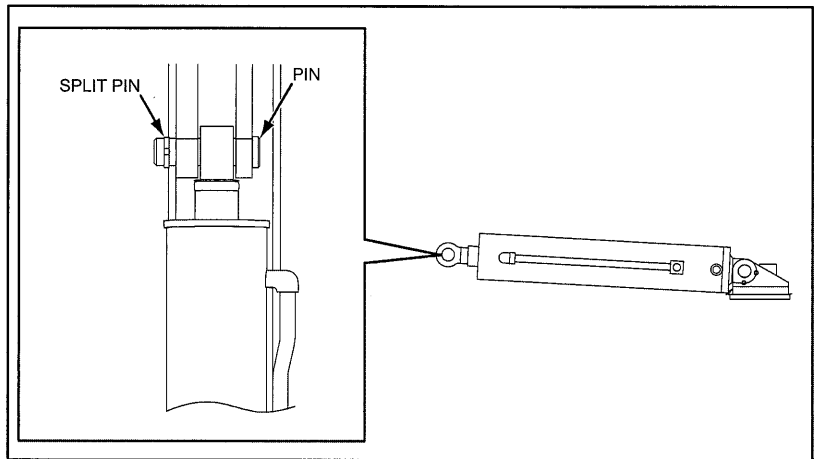

4.6 ASSEMBLY OF BOOM BASE

Although this machine is designed to be transported with the boom base attached, there would be a case that the machine would be transported without the boom base under certain reasons.

Prior to work, check the machine condition again.

- Machine must be placed on the firm and level ground.
- The crawlers are extended and fixing pins are installed to the crawlers and the shims are inserted on the axles

 **DANGER**

Do not stand on, or enter under/inside of the boom/jib being connected or disconnected.

Failure to observe these precautions may result in a serious injury or loss of life.

4.6.1 BOOM BASE INSTALLATION

1. Secure the backstop to prevent it from coming out.

With using proper rigging equipment and method, lift up the boom base with an assist crane and install it to the main machinery.

When lifting the boom should be horizontal on left and right.

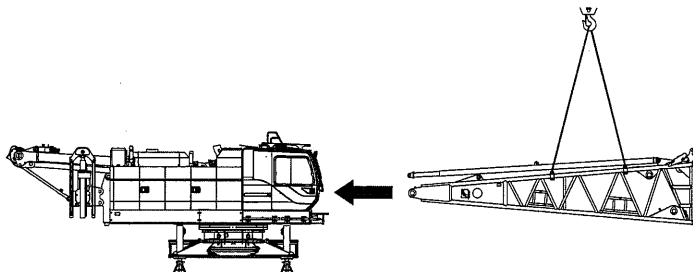

2. Apply grease on the boom foot pins and holes.
3. Align the boom foot pin holes on both side and insert the right side pin from inside then the left. To reduce the gap between the boom base and the swing frame, insert shims while inserting the foot pins.

Do not use hammer to force the shim into the gap.

Insert the lock pins from top to bottom and fix them with the retaining pins.

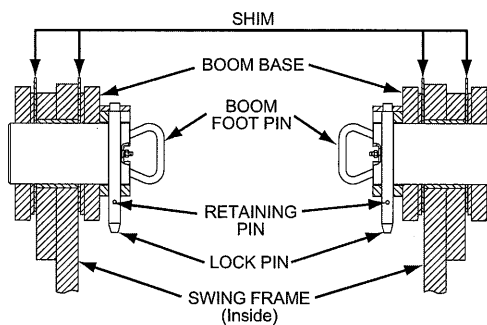

WARNING

Do not insert finger or hand into a pin hole when aligning, inserting or removing pin.

Failure to observe this precaution may result in a serious injury or loss of life.

- Place the boom base connector portion on the wood blocking and remove the sling wire rope.

⚠ WARNING

Do not lower the boom base tip below ground level.

Otherwise some components may be damaged.

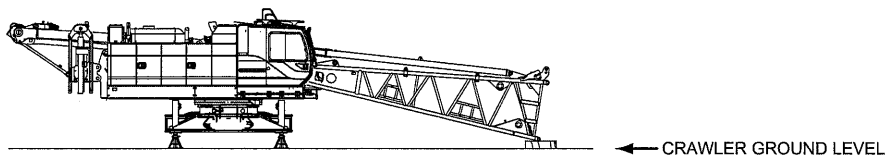

- Apply grease to the left and right boom foot pins at the grease fittings.

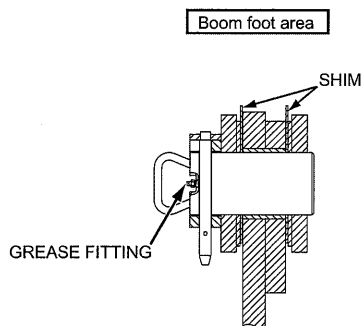

- Connect the cable reel and angle detector wiring refer to the article 3 "LOAD SAFETY DEVICE".

4.6.2 BACKSTOP INSTALLATION

Lift up the backstop outer pipe and slide inner pipe toward the main machinery.

Connect to pipe and swing frame with pins and spring pins.

Insert the pins from inner side of the swing frame.

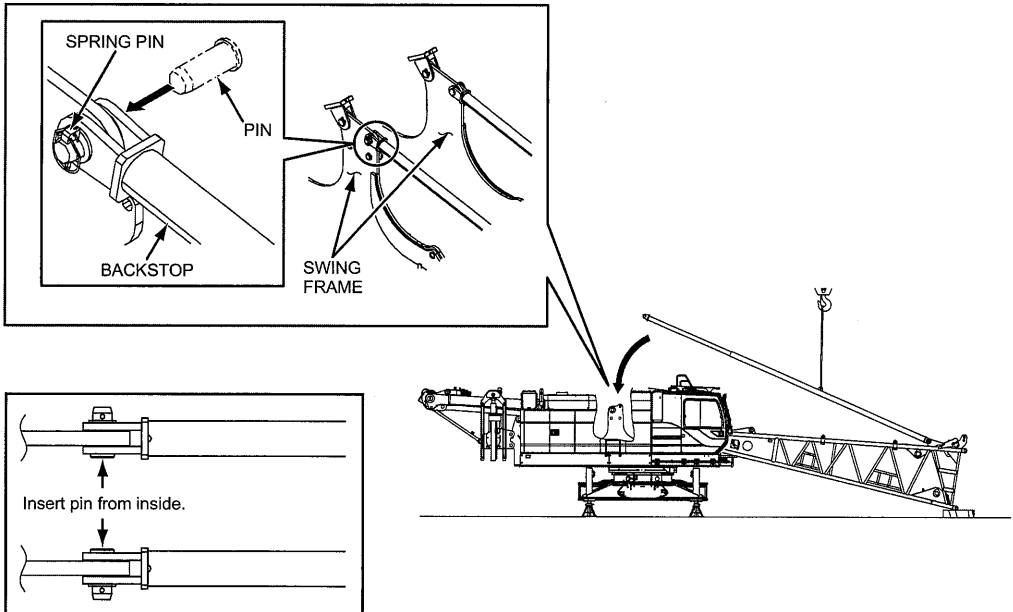

WARNING

Do not insert finger or hand into a pin hole when aligning, inserting or removing pin.

Failure to observe this precaution may result in a serious injury or loss of life.

WARNING

Do not stand under, or on inline or projection of the backstop to prevent accident.

Failure to observe this precaution may result in a serious injury or loss of life.

4.6.3 UPPER SPREADER INSTALLATION

By lifting the upper spreader with an assist crane, install the spreader at the boom base top bracket with pins.

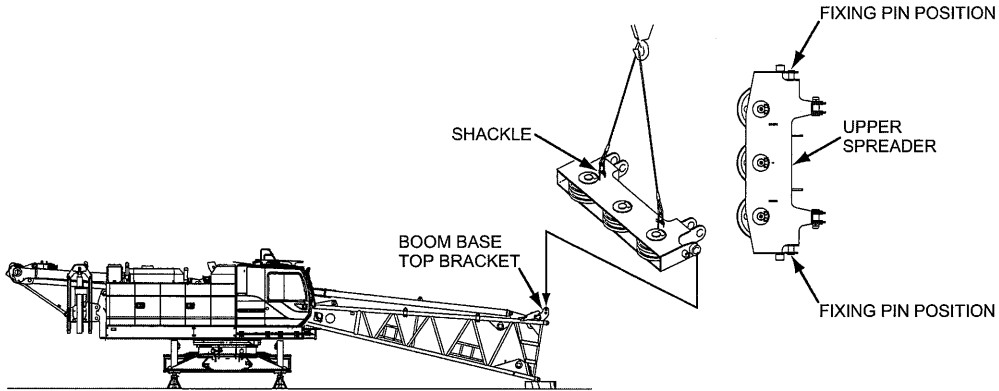

WARNING

Do not insert finger or hand into a pin hole when aligning, inserting or removing pin.
Failure to observe this precaution may result in a serious injury or loss of life.

WARNING

When working at an elevated location, watch your step and surroundings.
Utilize fall protection, walkway or aerial platform as needed.
Do not stand on component being connected or disconnected.
Failure to observe these precautions may result in a serious injury or loss of life.

4.6.4 REEVING BOOM HOIST WIRE ROPE

1. Reeving boom hoist wire rope

This is to explain reeving method when the boom hoist wire rope has been wound on the boom hoist drum.

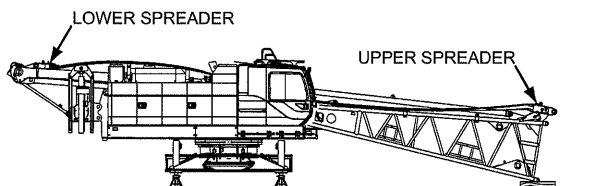

4

WARNING

Do not touch the wire rope with bare hands.

Use hand protection.

Pay attention to the running rope to prevent being caught.

Failure to observe these precautions may result in serious injuries or loss of life.

WARNING

Return levers to the neutral positions, and check safety around the machine before starting the engine.

Failure to observe this precaution may result in a serious accident.

2. Turn the boom drum control lever to lowering side to pay out the wire rope from the boom drum.
3. Reeve the wire rope through the upper spreader and the lower spreader preventing the wire rope from twisting, twining or coming out of sheave.

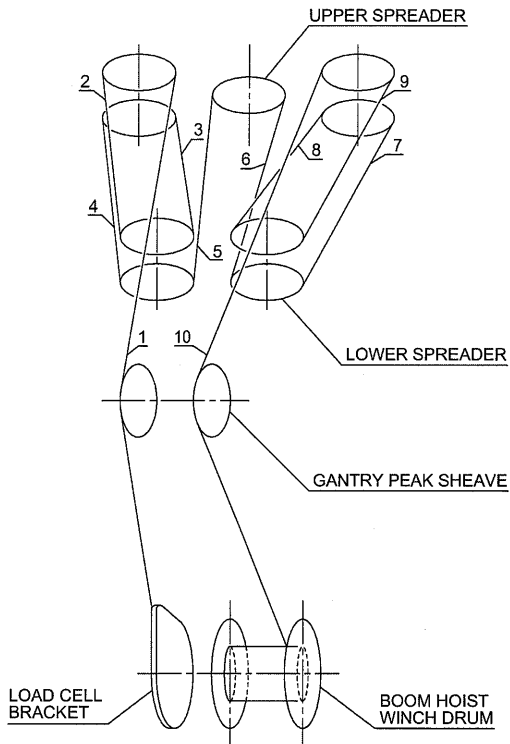

CAUTION

Be sure to follow the reeving order when passing the boom hoist wire rope through the upper and lower spreaders.

Otherwise wire rope interference may occur and result in a strand cut or damaged rope.

4. Fix the wire rope end to the winch link using the rope socket, wedge and clamp.

WARNING

When working at an elevated location, watch your step and surroundings.

Utilize fall protection, walkway or aerial platform as needed.

Do not stand on component being connected or disconnected.

Failure to observe these precautions may result in a serious injury or loss of life.

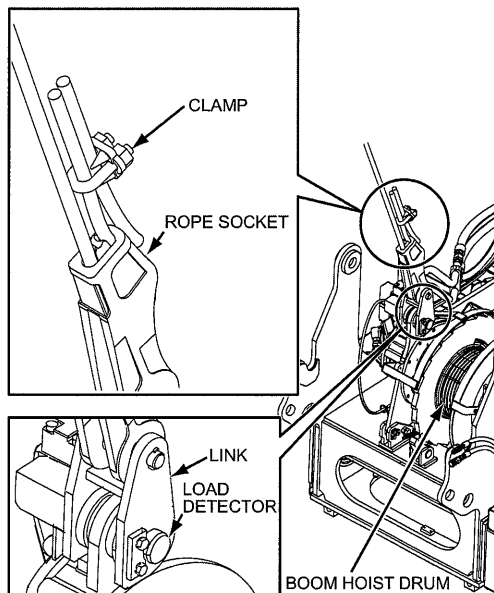

4.6.5 INSTALLATION OF BOOM HOIST WIRE ROPE TO THE DRUM

⚠ WARNING

Do not put finger or hand into pin hole when inserting or pulling out the pins.

Failure to observe this precaution may result in a serious injury.

⚠ WARNING

Turn each control lever to neutral and check the machine surrounding area for safety before starting the engine.

⚠ WARNING

Do not touch the wire rope with bare hands.

Use hand protection.

Pay attention to the running rope to prevent being caught.

Failure to observe these precautions may result in serious injuries or loss of life.

1. Secure the wire rope end to the boom hoist drum with the wedge.
2. Wind up the wire rope to the boom drum.

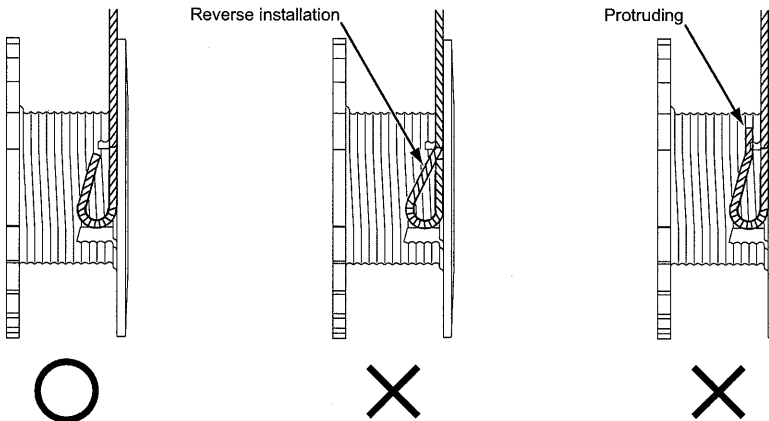

4.6.6 REEVING HOOK HOIST WIRE ROPE

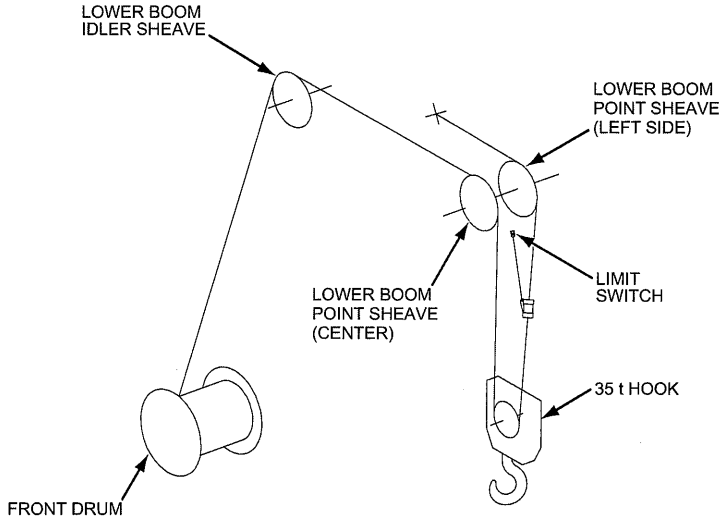

4.7 DISASSEMBLY OF BOOM BASE

4.7.1 WINDING UP OF BOOM HOIST ROPE

1. Winding up of the boom hoist rope to the boom hoist drum is explained here.

WARNING

When working at an elevated location, watch your step and surroundings.

Utilize fall protection, walkway or aerial platform as needed.

Do not stand on component being connected or disconnected.

Failure to observe these precautions may result in a serious injury or loss of life.

2. Confirm that the upper spreader is fixed to the boom base top bracket with pin.

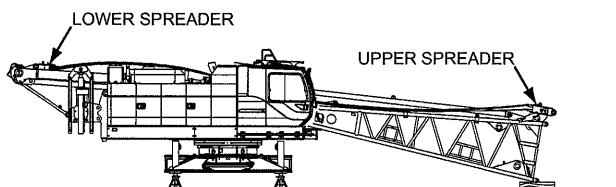

3. Remove the wire rope from the boom hoist winch link.

WARNING

Do not touch the wire rope with bare hands.

Use hand protection.

Pay attention to the running rope to prevent being caught.

Failure to observe these precautions may result in serious injuries or loss of life.

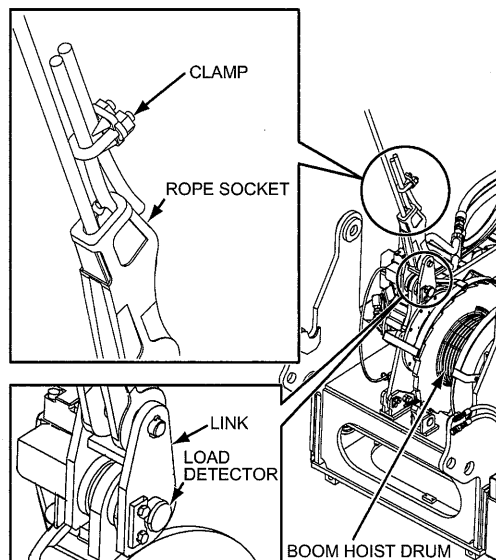

[4. ASSEMBLY/DISASSEMBLY OF MAIN MACHINERY]

4. Wind up the wire rope to the boom hoist drum slowly by turning the boom drum control lever to raising side.

Apply some tension on the boom hoist wire rope and tap lightly on the rope with hammer to prevent rough spooling.

5. When the boom hoist wire rope is completely wound up, fix the rope end to the drum outer most layer with the steel wire.

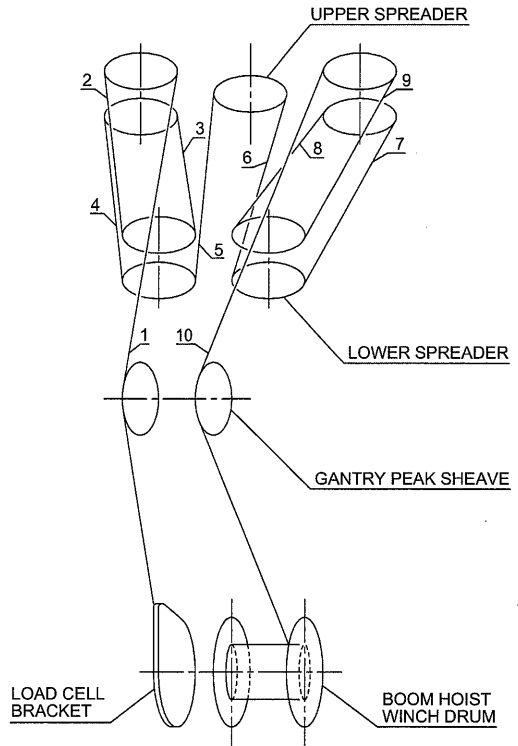
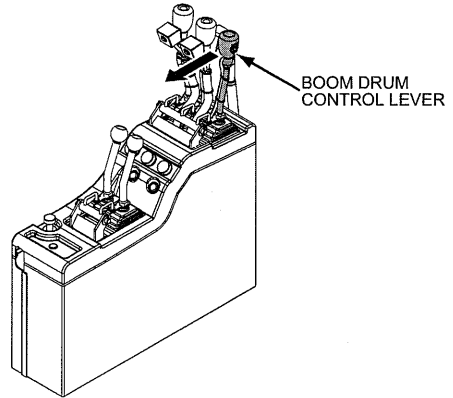

4.7.2 UPPER SPREADER REMOVAL

The upper spreader removal after the boom hoist wire rope is wound up to the boom hoist drum is explained here.

1. Remove the fixing pins at the boom base top bracket, lift the upper spreader with shackles by lifting points.
2. Lower the upper spreader on the ground with an assist crane.
Place it on wood blocking.

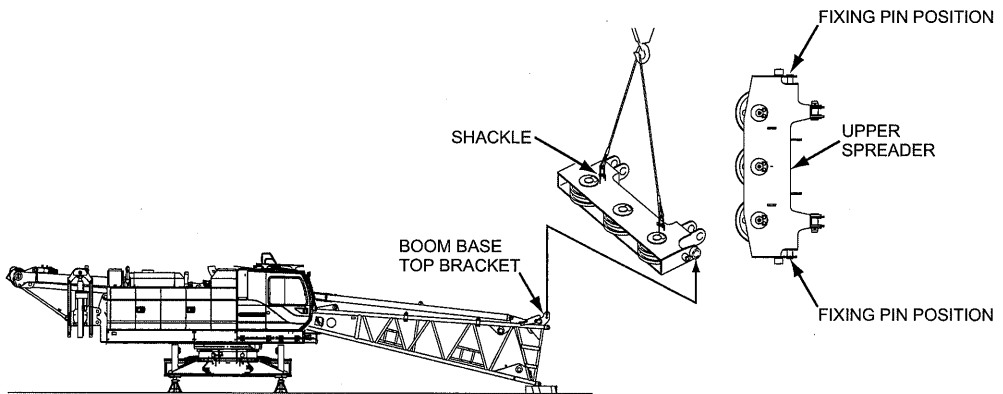

WARNING

Do not insert finger or hand into a pin hole when aligning, inserting or removing pin.
Failure to observe this precaution may result in a serious injury or loss of life.

WARNING

When working at an elevated location, watch your step and surroundings.
Utilize fall protection, walkway or aerial platform as needed.
Do not stand on component being connected or disconnected.
Failure to observe these precautions may result in a serious injury or loss of life.

4.7.3 BACKSTOP REMOVAL

1. Apply sling at lifting point, lift up the backstop pipe slightly with an assist crane.
2. Remove the spring pin and the pin at the swing frame and lift off the backstop pipe then retract it toward to the boom base.

Attach the removed spring pins and pins to the backstop. (on both side)

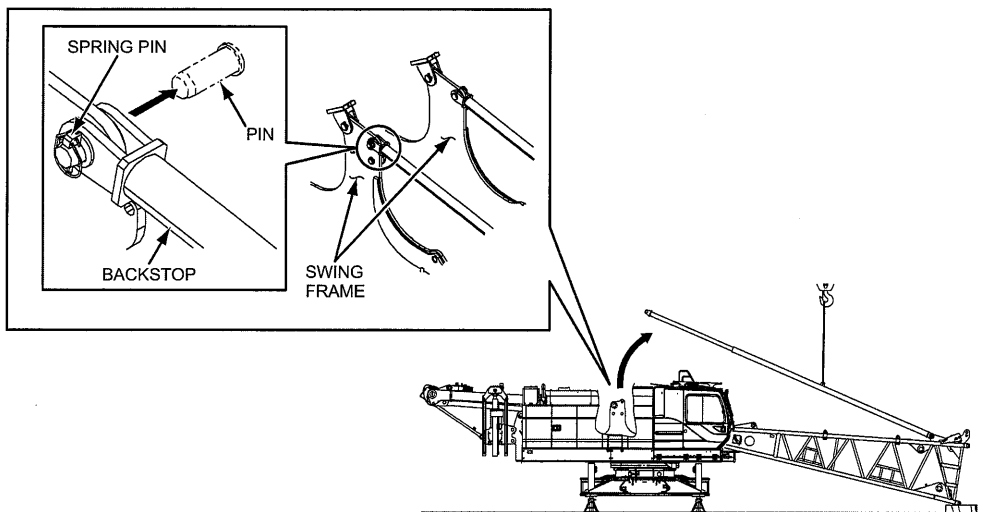

WARNING

Do not insert finger or hand into a pin hole when aligning, inserting or removing pin.
Failure to observe this precaution may result in a serious injury or loss of life.

WARNING

Do not stand under, or on inline or projection of the backstop to prevent accident.
Failure to observe this precaution may result in a serious injury or loss of life.

3. While supporting the backstop with an assist crane, secure the backstop to the boom base with wire. (Both right and left sides)

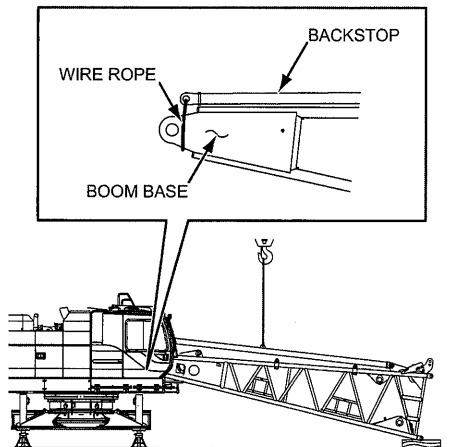

4.7.4 REMOVAL OF BOOM BASE

Although this machine is designed to transport with the boom base attached, this article explains the removal procedure of the boom base if it becomes necessary to transport with the boom base removed.

Prior to work, check the machine condition again.

- The main machinery is placed on firm and level ground.
- The crawlers are extended to "WORK" position.

⚠ DANGER

Do not stand on, or enter under/inside of the boom/jib being connected or disconnected.

Failure to observe this precaution may result in a serious injury or loss of life.

1. Remove the wiring of the cable reel and the angle detector refer to the article 3 "LOAD SAFETY DEVICE".
2. Lower the boom base connector portion on the wood blocking.
3. Support the boom base with an assist crane and pull out the cab side (right side) boom foot pin and then the left side boom foot pin. Slide out the shims.

⚠ WARNING

Do not insert finger or hand into a pin hole when aligning, inserting or removing pin.

Failure to observe this precaution may result in a serious injury or loss of life.

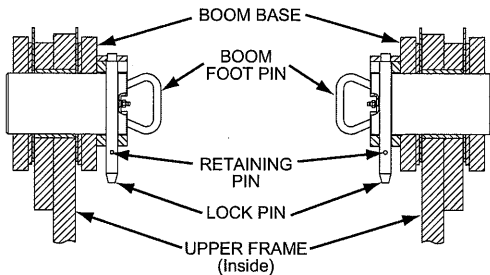
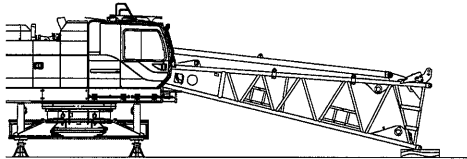

4. Lift the boom base with the assist crane and remove it from the main machinery and lower it on the ground.

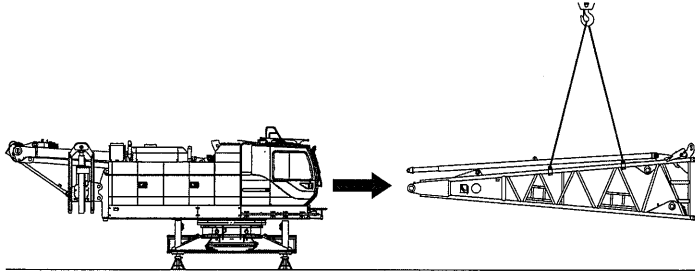

4.8 EXTENDING/RETRACTING THE CRAWLERS

4.8.1 EXTENDING THE CRAWLER

Although the crawler extending can be done without the boom base, this article explains the procedure with boom base attached.

Perform the crawler extending/retracting work under the following conditions.

- Place
Ground should be firm and level.
If needed, place steel plates.
- Main machinery configuration
Counterweight : None
Carbody weight : None
Boom : 15.2 m (50 ft.) or less
Boom angle : Approx. 60 degrees

Prior to extending or retracting, clean the axle extension thoroughly and apply grease (Molybdenum disulphide grease) to the slide area.

If mud is left on, extension or retraction work could be difficult.

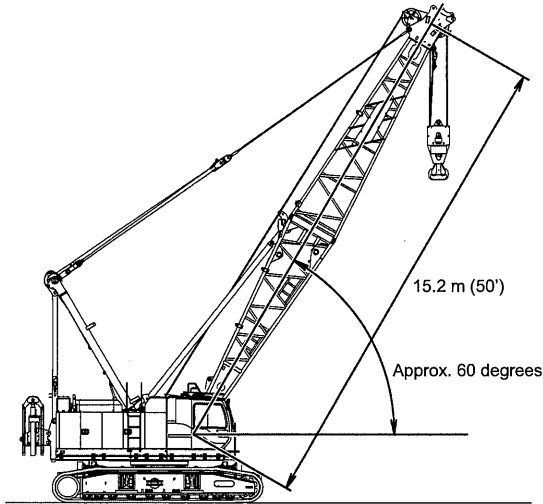

⚠ DANGER

When the translifter is to be used, set the main machinery on level and firm ground.

When the translifter is used on inclined or soft ground, a serious accident such as overturning of the main machinery or damaging the translifter may be caused.

Failure to observe this precaution may result in a serious accident.

⚠ DANGER

When the translifter is to be used, ensure to remove all the counterweights and the carbody weight.

If the translifters are used with these weights installed, a serious accident such as overturning of the main machinery or damaging the translifter may be caused.

Failure to observe this precaution may result in a serious accident.

⚠ DANGER

Crane work prohibited if translifter is at "transport with crawler position".

If the machine swings at this position, the machine would overturn to rear side.

Ensure to set the machine to "translifter work position".

Failure to observe this precaution may result in a serious injury or loss of life.

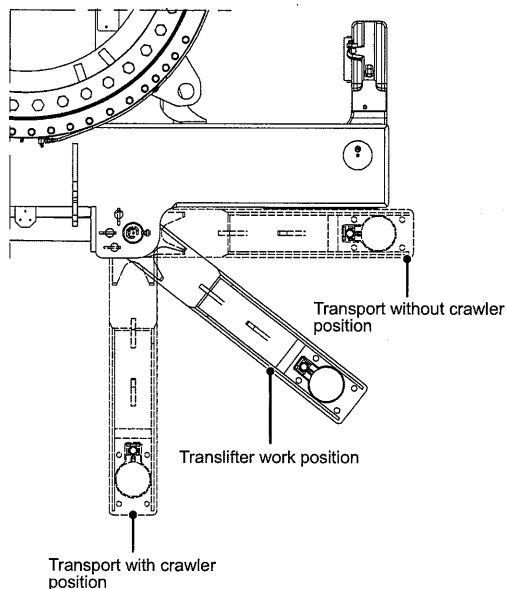

1. Handling of the crawler connecting links differs between those of "LF", "RR" and those of "RF", "LR".

Place pins (1a) of left front side and right rear side against the plate (m).

Pull out pins (1b) of right front and left rear side in advance.



Do not put finger or hand into pin hole.

Failure to observe this precaution may result in a serious injury.

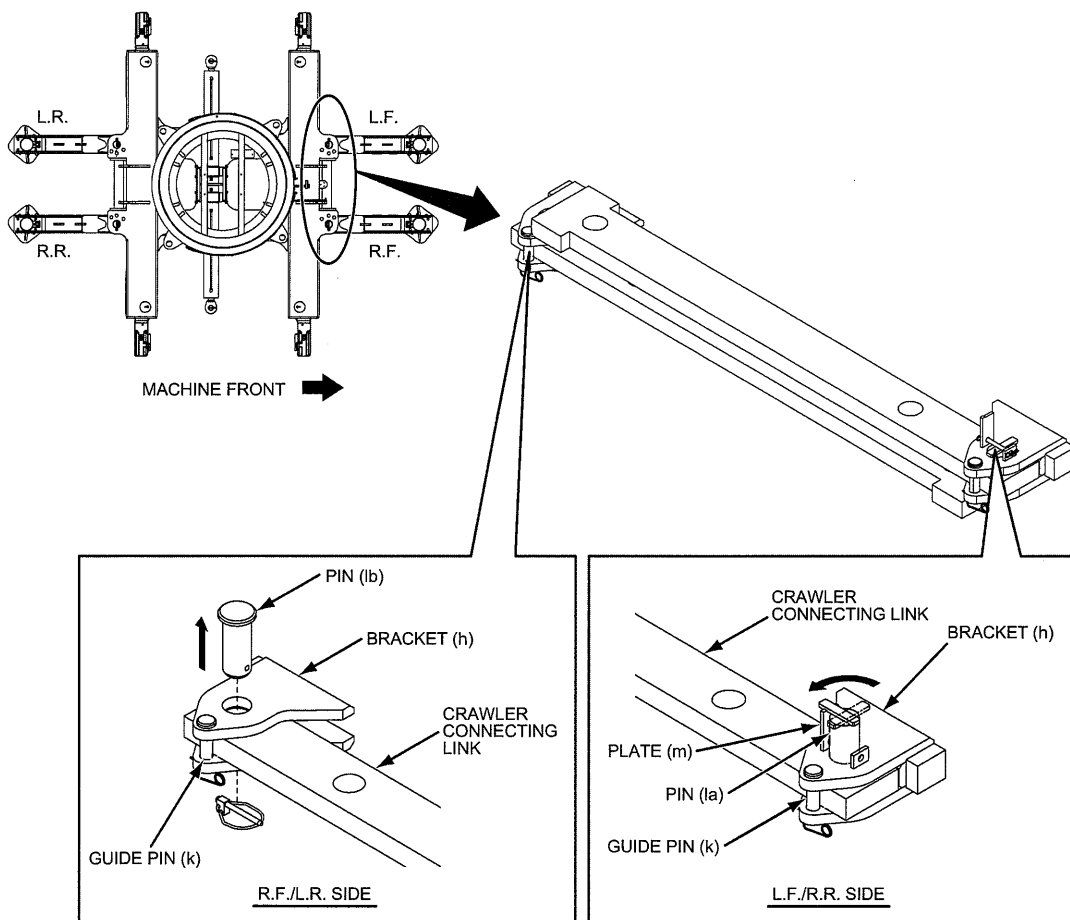

2. Pull out the pin (s) which secure the axle extension and the crawler frame.
Remove the retaining pin before pulling the pin (s) out. (4 pieces on right and left)

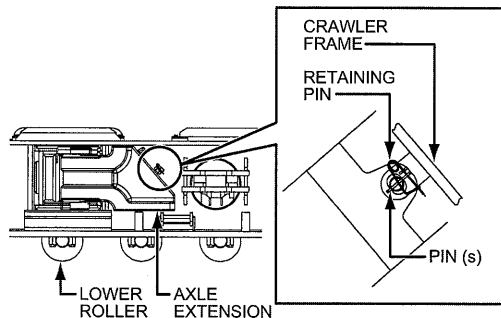

4

3. Turn all four axle extensions for 90 degrees toward outside to make them parallel to the axles.
Insert the pin (s) into the crawler frame bracket hole and secure it with the retaining pin.

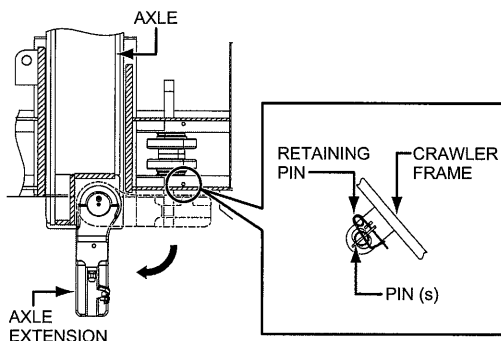

4. Insert the axle extension retaining bracket (t) to the pivot area of the axle extension from the direction as here.
Stow the bracket (t) to the crawler frame.

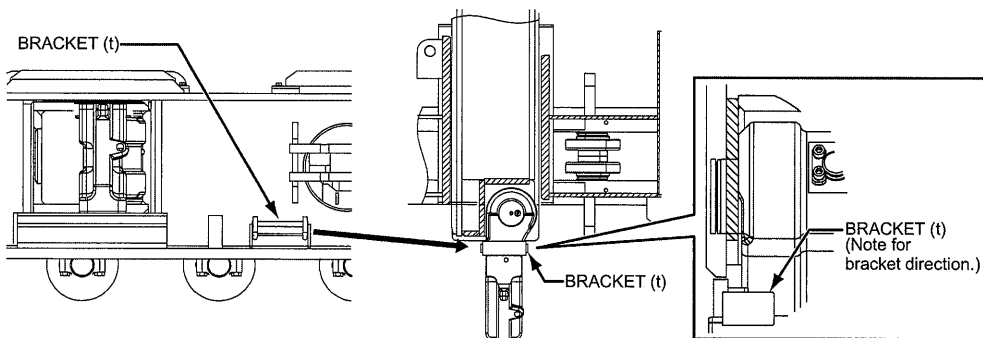

5. Take out the clearance adjusting shims between the crawler and the axle.

WARNING

Do not put finger or hand into the clearance between the crawler and the axle when inserting or removing the shims to prevent serious injury. Failure to observe this precaution may result in a serious injury.

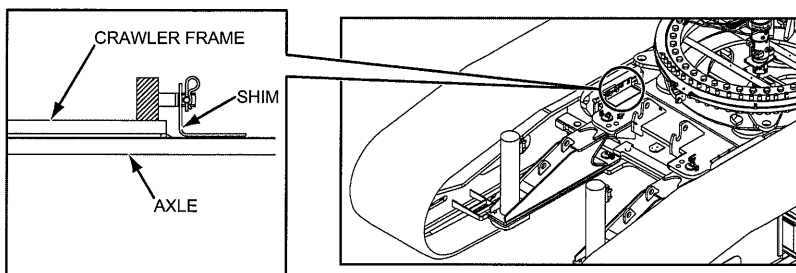

6. Set the translifter to the "transport with crawler position", and install the floats to the vertical cylinders.
7. Extend the vertical cylinder to lift the machine until the lower rollers are just clear of the track.

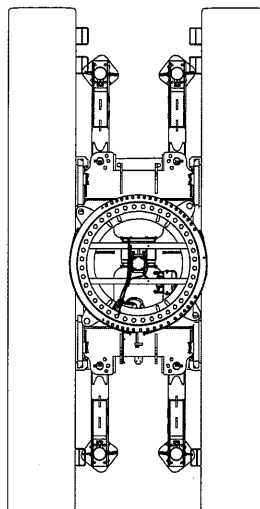

⚠ DANGER

If the machine swings at transport position, the machine would overturn to rear side.
Failure to observe this precaution may result in a serious injury or loss of life.

8. Install the float to the vertical cylinder and fix with the pin.
Place steel plates under the floats for safety.

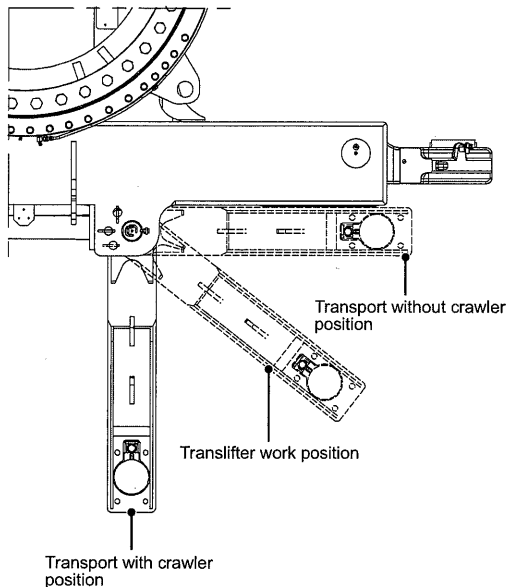

4

⚠ DANGER

If the main machinery is lifted and swing with the translifter set at the "transport with crawler position", the machine may overturn, resulting in a serious accident.
Never attempt to swing the upper machinery.

⚠ CAUTION

The float weight approx. 32 kg (72 lbs).
Handle the float with two persons to prevent injuries.

9. Ensure that the hydraulic hoses are connected to the vertical cylinders.
(Hydraulic hose 4 locations total 8 pieces)

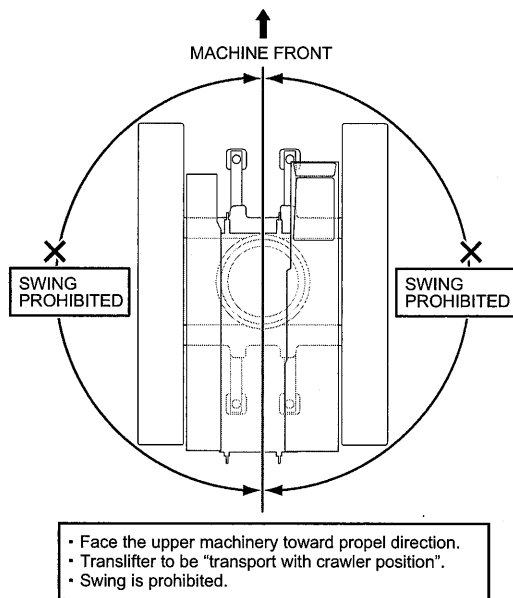

⚠ CAUTION

Check to see that the coupler does not come apart when pulled.

10. By controlling the crawler extend control switch of the remote controller, extend both crawlers (right and left) toward outside.

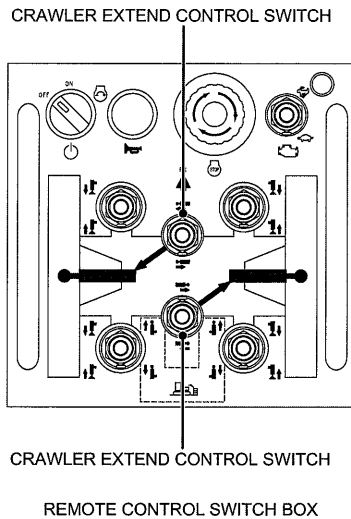

11. After extending the crawler for approx. 400 mm (1 ft. 3-3/4 in.) (Ref : ext/ret stroke is 900 mm [2 ft. 11-7/16 in.]), stop the crawler ext/ret switch once and place the pin (1a) on extending/retracting side on the link.

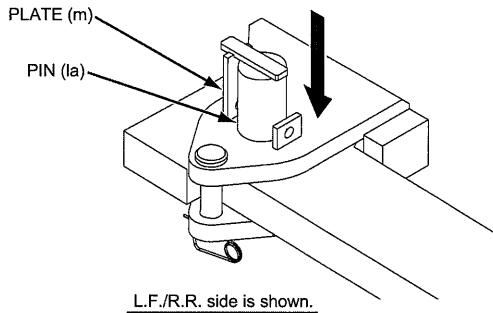

12. By extending the crawler to the extended position, the pin (1a) and (1b) will be inserted into the pin hole.

Insert the retaining pin on the pin (1a) and (1b) and fix them with right and left lock pins.

⚠ WARNING

Do not put finger or hand into pin hole.

Failure to observe this precaution may result in a serious injury.

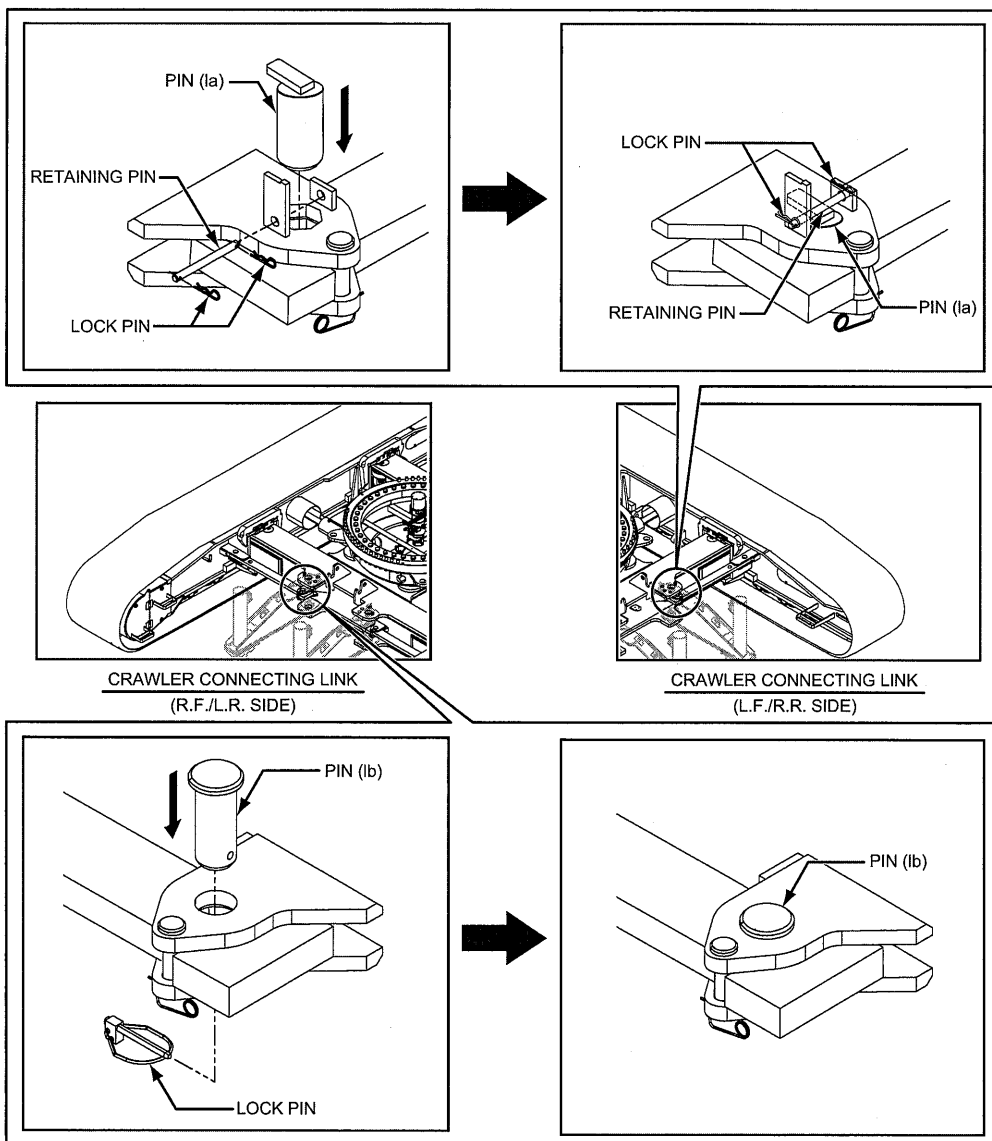

13. Retract the vertical cylinder, and remove the float.
14. Swing the upper machinery to widen clearance between the crawler and the axle and install the adjusting shims at four places.
Each shim has a unique number stamped and install it accordingly.

⚠ WARNING

Do not put finger or hand into the clearance between the crawler and the axle when inserting or removing the shims to prevent serious injury. Failure to observe this precaution may result in a serious injury.

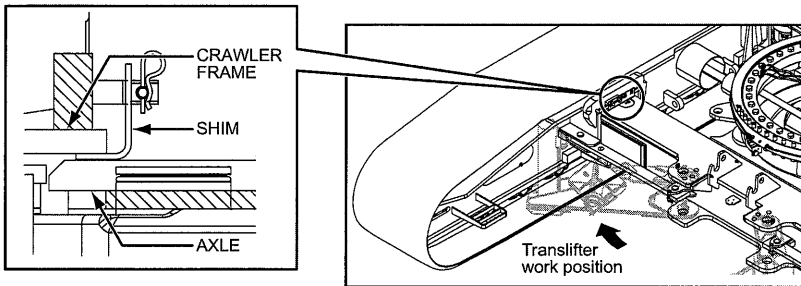

⚠ CAUTION

Insert the adjusting shims at all axle. Otherwise the crawlers would become misaligned and result in premature shoes or roller wear.

4.8.2 RETRACTING THE CRAWLER

Perform the crawler extending/retracting under the following conditions.

- Place
Ground should be firm and level.
If needed, place steel plates.
- Main machinery configuration
Counterweight : None
Carbody weight : None
Boom : 15.2 m (50 ft.) or less
Boom angle : Approx. 60 degrees

Prior to extending or retracting work, clean the axle extension thoroughly and apply grease (Molybdenum disulphide grease) to the slide area.

If mud is left on, extension or retraction work could be difficult.

DANGER

When the translifter is to be used, set the main machinery on level and firm ground.

When the translifter is used on inclined or soft ground, a serious accident such as overturning of the main machinery or damaging the translifter may be caused.

Failure to observe this precaution may result in a serious accident.

DANGER

When the translifter is to be used, ensure to remove all the counterweights and the carbody weight.

If the translifters are used with these weights installed, a serious accident such as overturning of the main machinery or damaging the translifter may be caused.

Failure to observe this precaution may result in a serious accident.

⚠ DANGER

Crane work prohibited if translifter is at “transport with crawler position”.

If the machine swings at this position, the machine would overturn to rear side.

Ensure to set the machine to “translifter work position”.

Failure to observe this precaution may result in a serious injury or loss of life.

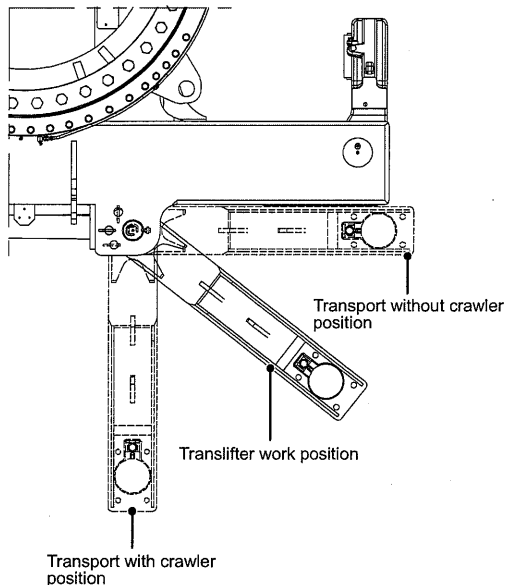

1. Install the float to the vertical cylinder and fix with the pin.
Place steel plates under the floats for safety.

⚠ CAUTION

The float weight approx. 32 kg (72 lbs).

Handle the float with two persons to prevent injuries.

2. Ensure that the hydraulic hoses are connected to the vertical cylinders.
(Hydraulic hose 4 locations total 8 pieces)

⚠ CAUTION

Check to see that the coupler does not come apart when pulled.

- Handling of the crawler connecting links differs between those of "LF", "RR" and those of "RF", "LR".

Place pins (1a) of left front side and right rear side against the plate (m).

Pull out pins (1b) of right front and left rear side in advance.



Do not put finger or hand into pin hole.

Failure to observe this precaution may result in a serious injury.

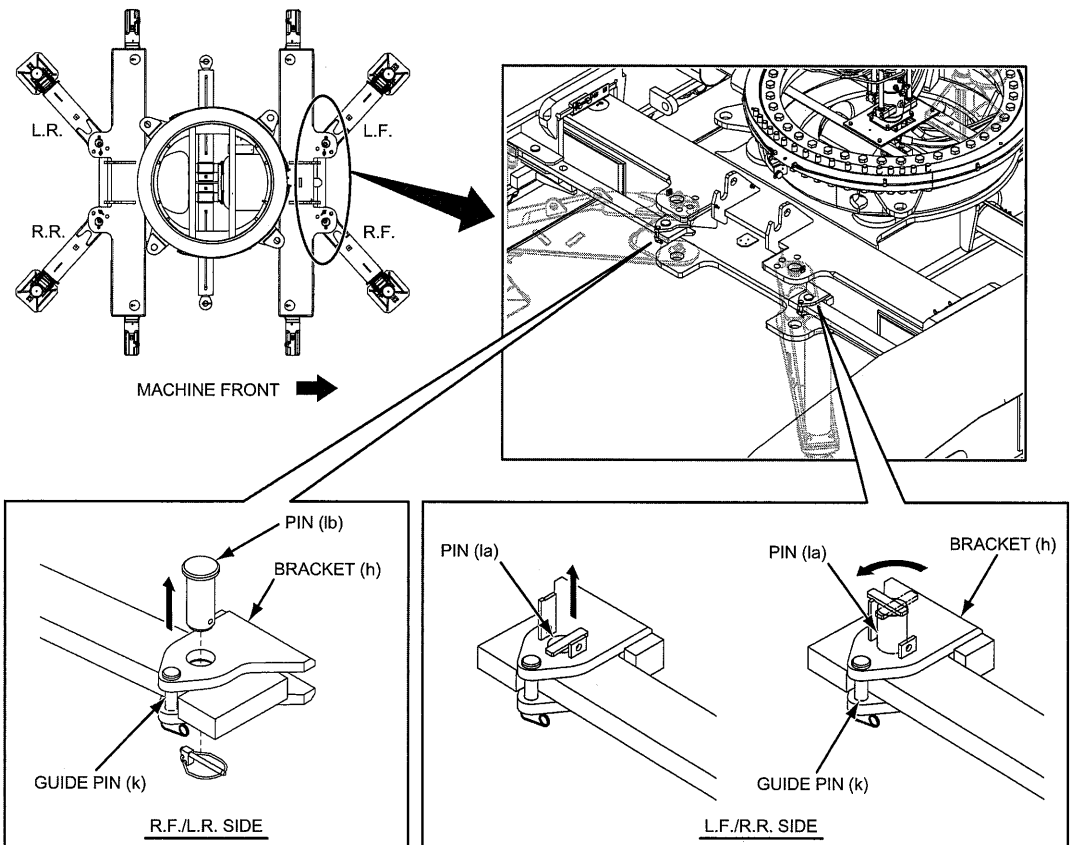

Note

Apply grease on the sliding surfaces on the axle with the crawler prior to work. (4 locations)

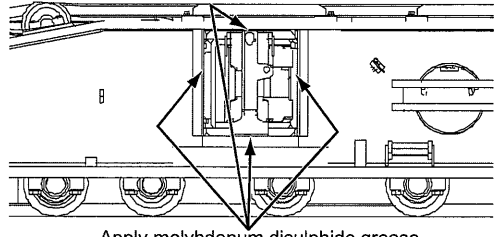

Apply molybdenum disulphide grease.

4. Swing the main machinery to widen the clearance between the crawler and axle and remove the adjusting shims at four places. Each shim has a unique number stamped and stow it accordingly.

WARNING

Do not put finger or hand into the clearance between the crawler and the axle when inserting or removing the shims to prevent serious injury. Failure to observe this precaution may result in a serious injury.

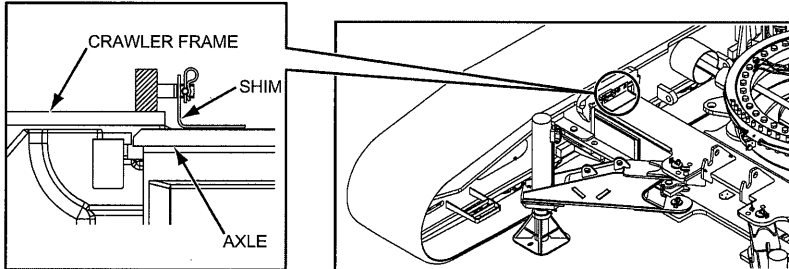

5. Set the translifter to the "transport with crawler position", and install the float to the vertical cylinder.
6. Extend the vertical cylinder to lift the machine until the lower rollers are just clear of the track.

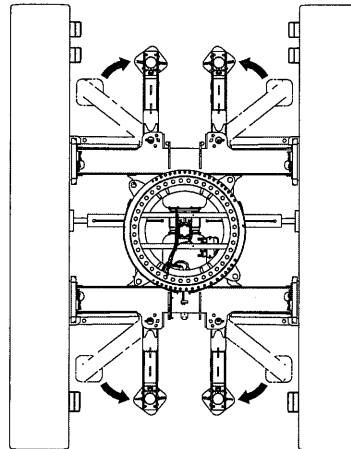

4

⚠ DANGER

If the machine swings at transport position, the machine would overturn to rear side. Failure to observe this precaution may result in a serious injury or loss of life.

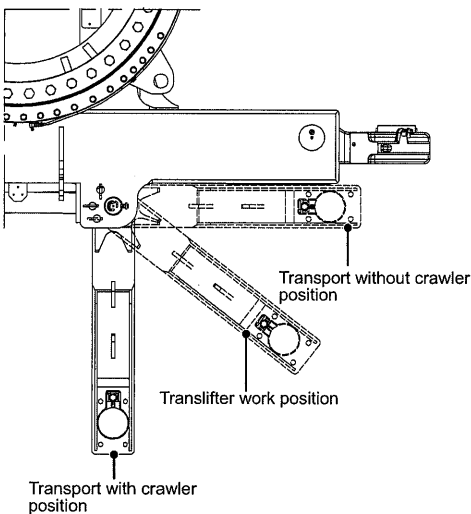

7. By controlling the crawler extend control switch of the remote controller, retract both crawlers (right and left) toward inner side.
8. After retracting the crawler for approx. 400 mm (1 ft. 4 in.) (Ref. ext/ret stroke is 900 mm [2 ft. 11 in.]), stop the crawler ext/ret switch once and place the pin (la) and (lb) which has been placed against the retracting plate (m) on the link.

CRAWLER EXTEND CONTROL SWITCH

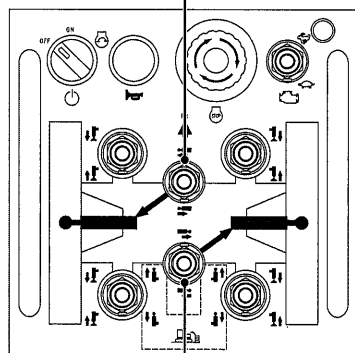

CRAWLER EXTEND CONTROL SWITCH

REMOTE CONTROL SWITCH BOX

9. Retract the crawler to the retracted position and confirm that the pin (la) and (lb) is inserted at all 4 locations.
Then set the retraining pins and secure them with the lock pins.



Do not put finger or hand into pin hole.
Failure to observe this precaution may result in a serious injury.

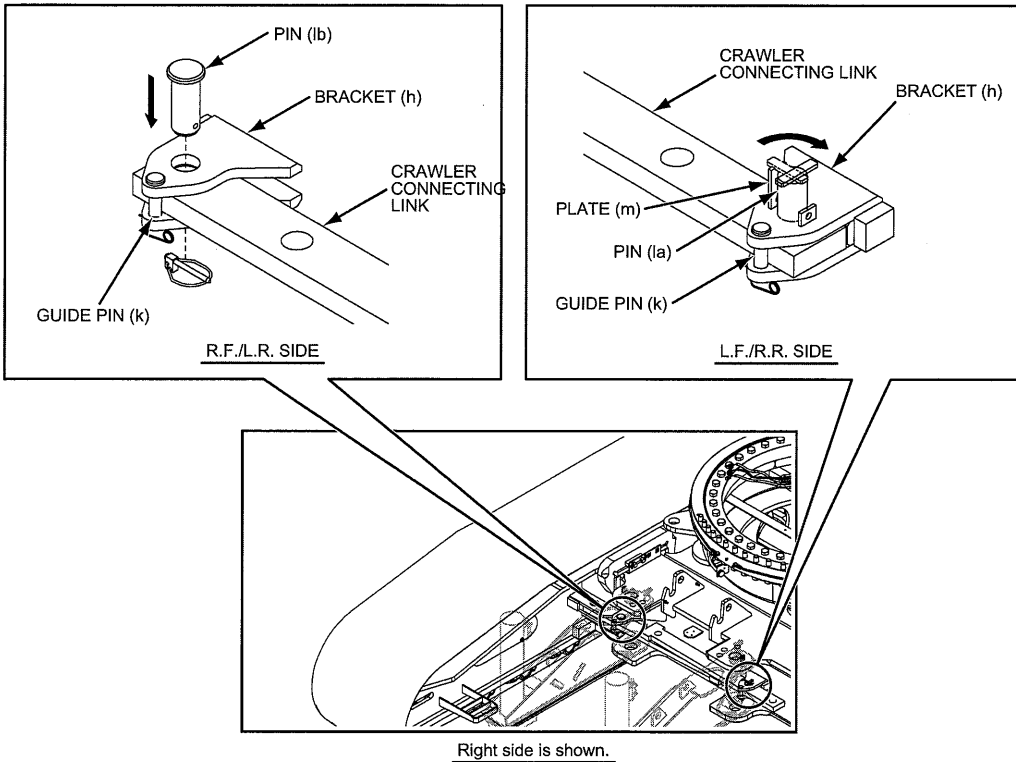

10. Retract the vertical cylinder, and remove the float.

- Remove the retaining bracket (t) by the pivot area of the axle extension and move it to the stowing position at all 4 locations.

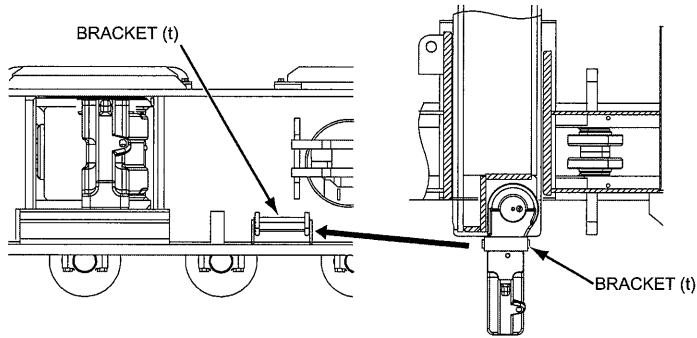

4

- Rotate all four axle extensions for 90 degrees toward the frame to make them right angle with axles.

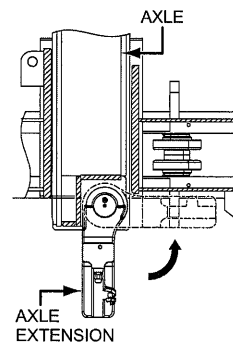

- Secure the axle extension to the crawler frame with the pin (s) and insert the retaining pin on all four locations.

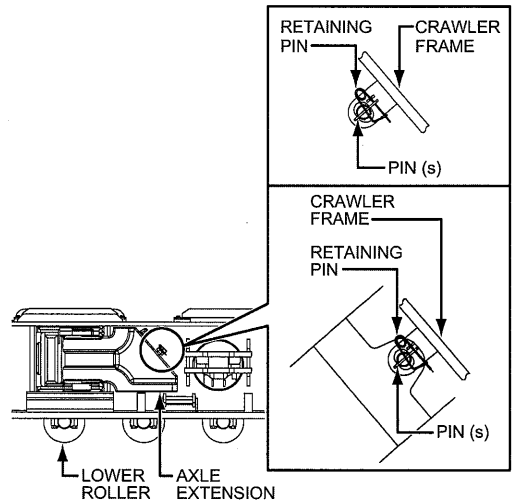

5. ASSEMBLY/DISASSEMBLY OF CRANE ATTACHMENT

5.1	ASSEMBLING THE ATTACHMENT	5-5
5.1.1	ARRANGEMENT OF BOOM/JIB/GUY LINE	5-6
5.1.2	INSTALLING THE BOOM TIP	5-13
5.1.3	INSTALLATION OF THE BASIC GUY LINE.....	5-14
5.1.4	CONNECTING THE BOOM INSERT.....	5-16
5.1.5	INSTALLING THE CABLE ROLLERS.....	5-27
5.1.6	CONNECTING THE BOOM GUY LINES.....	5-28
5.1.7	CAUTION FOR CANTILEVER.....	5-30
5.1.8	FRONT DRUM WIRE ROPE REEVING.....	5-31
5.1.9	ASSEMBLING THE JIB.....	5-36
5.1.10	REEVING OF REAR DRUM WIRE ROPE	5-40
5.1.11	INSTALLING THE AUXILIARY SHEAVE.....	5-43
5.1.12	REEVING THE REAR DRUM WIRE ROPE TO THE AUXILIARY SHEAVE.....	5-44
5.1.13	FUNCTION CHECK OF EACH LIMIT SWITCH.....	5-46
5.2	ERECTING THE ATTACHMENT	5-47
5.2.1	CONFIRMATION BEFORE ERECTING THE ATTACHMENT	5-47
5.2.2	ERECTING THE ATTACHMENT	5-48
5.3	LOWERING THE ATTACHMENT	5-51
5.3.1	LOWERING THE ATTACHMENT	5-52
5.4	DISASSEMBLING THE ATTACHMENT	5-53
5.4.1	TREATMENT OF OVERHOIST LIMIT SWITCH WIRING.....	5-53
5.4.2	WINDING UP THE FRONT/REAR DRUM WIRE ROPES.....	5-56
5.4.3	DISASSEMBLING THE JIB.....	5-58
5.4.4	REMOVING THE AUXILIARY SHEAVE	5-60
5.4.5	REMOVING THE BOOM GUY LINE	5-61
5.4.6	REMOVING THE CABLE ROLLER.....	5-63
5.4.7	DISASSEMBLING THE BOOM.....	5-64
5.5	CAUTION WHEN TRANSPORTING BOOM.....	5-67

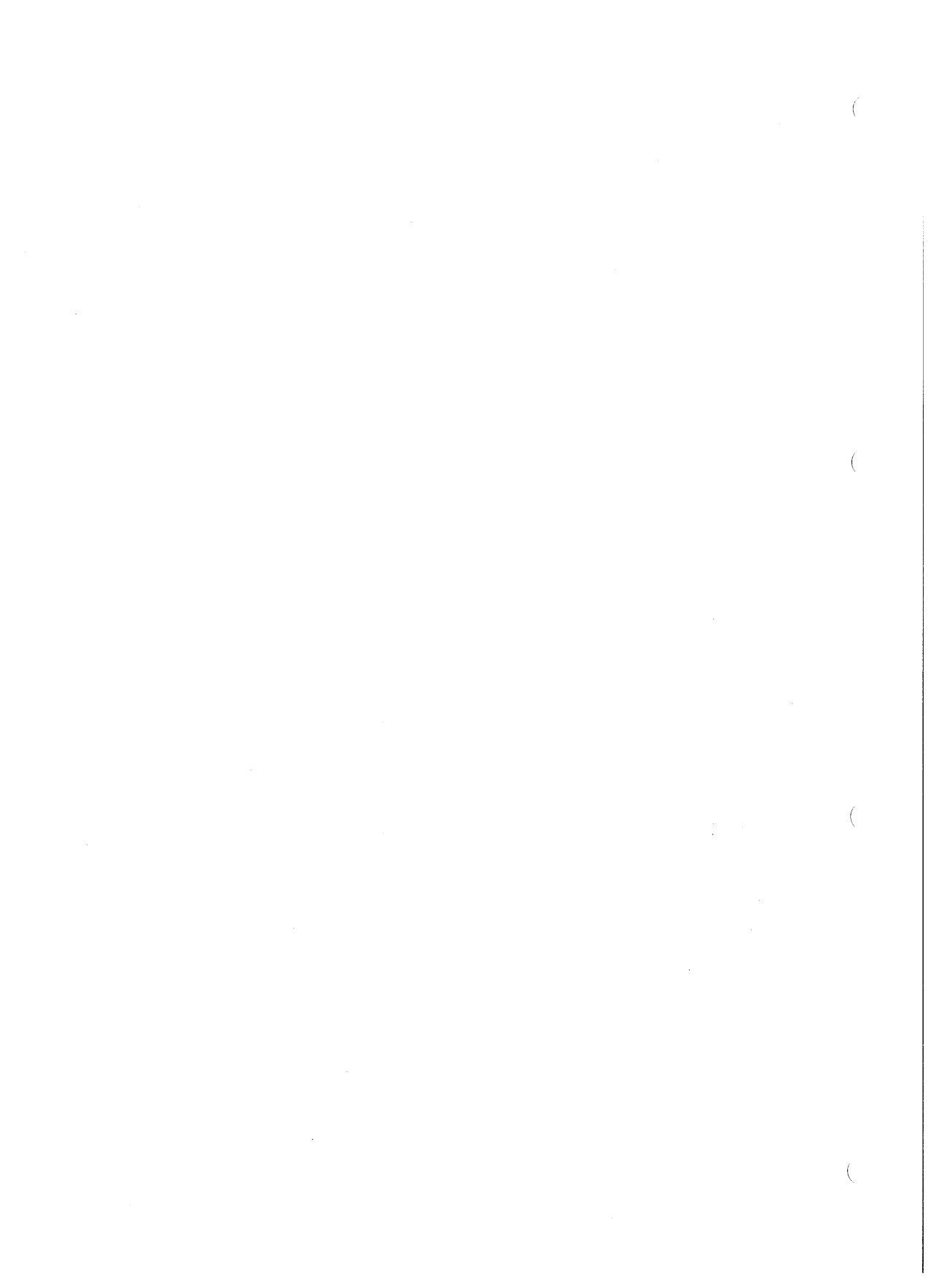

5. ASSEMBLY/DISASSEMBLY OF CRANE ATTACHMENT

This section covers assembling, erecting, lowering and disassembling of the crane attachment and transport of the boom.

This assembly procedure starts when the machine is under the following conditions.

- The crawler is extended to the extended position.
- Counterweights and carbody weights are installed for the desired configuration.
- The boom hoist rope has been roved through the upper and lower spreader and the gantry is in work position (high gantry).
- The boom base is attached to the main machinery.
- The crane backstops have been installed.

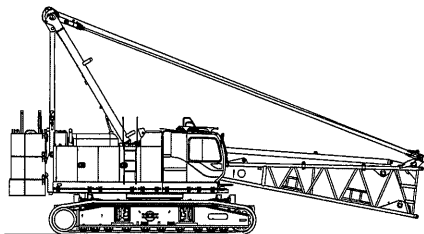

5

⚠ DANGER

Do not lower the boom base tip below ground level.

Otherwise some components maybe damaged.

Before starting the work, confirm the following items.

1. Place

(1) Check point prior to work

- A qualified supervisor who is competent in the procedures.
- Hold a pre-work meeting for safety.
Review potential hazards and hazardous locations in the course of work.
- Make every worker aware of work contents, procedure and signal.
- Inspect assist crane and other equipment for their condition.

(2) Securing place

- Select a firm and level space enough for the task.
Place steel plates or crane mats.
- Assign areas for the assist crane, parts storage and trailer access.
- The ground shall be drained unless the place is in marshes or wetland.

2. Work procedure and prearrangement for safety

Have a qualified supervisor who is competent in assembly and disassembly procedures.

Before assembling work, gather the all concerned to make previous arrangement for the working procedure and safety, and make precise role and responsibility of each person.
Review potential hazards and hazardous locations in the course of work.

3. Preparation before work

- Secure the setting place of assist crane and prepare the required lifting gears, protective materials and tools.
- Secure required number of workers for the work.
(Crane operators, assistant operators, slinging workers and signal persons)
- Take appropriate action to keep personnel off the work area other than workers during work.

⚠ DANGER

Do not stand on, or enter under/inside of the boom/jib being connected or disconnected.

Failure to observe these precautions may result in a serious injury or loss of life.

⚠ DANGER

Do not apply slings to a sharp edged part directly to prevent the damage.

Use corner protectors.

Apply the sling to the guy cable pin hole or install a shackle to bracket for lifting.

Failure to observe these precautions may result in a serious accident.

⚠ WARNING

When working at an elevated location, watch your step and surroundings.

Utilize fall protection, walkway or aerial platform as needed.

Do not stand on component being connected or disconnected.

Failure to observe these precautions may result in a serious injury or loss of life.

⚠ WARNING

Do not insert finger or hand into a pin hole when aligning, inserting or removing pin.

Failure to observe this precaution may result in a serious injury or loss of life.

⚠ WARNING

Secure guy lines on the corresponding boom/jib component at both ends during preparation.

Failure to observe this precaution may result in a serious injury or loss of life.



Do not handle boom or jib sections with chains, hooks or wire rope attached directly to main chords or lacings.

Use soft material sling.

4. Cautions during assembly work

- During assembly or disassembly work, install the waterproof cap on the cable end of the hook overhoist preventing device.
During crane work, wire the overhoist cable properly and remove the waterproof cap.
- Refer to the article 8 "DIMENSION, WEIGHT OF EACH COMPONENT" for weight, dimension during assembly.
- The operator has to be informed if any person moved to out of sight from the operator or at hazardous location when equipment or machine part moves.

5.1 ASSEMBLING THE ATTACHMENT

TOOL

- Attached tool set
- Assist crane (25 t capacity)
- Wire rope slings
- Synthetic fiber sling
- Wood block
- Corner protectors
- Bar : Φ 20 mm \times 300 mm (Φ 13/16 in. \times 12 in.)
- Ratchet lever hoist (3 t)

When assembling the crane attachment, press  (assy/disassy icon).

Then, the load safety device enters the assy/disassy mode, and the automatic stop is canceled.

Note

Press and hold  (assy/disassy icon) for 1 second or more.

Note

When the boom angle is high, assy/disassy mode cannot be set.

When the boom is raised after the assembly, assy/disassy mode will be released.

Refer to the article 8 "DIMENSION, WEIGHT OF EACH COMPONENT" for individual dimension, weight of the crane attachment.

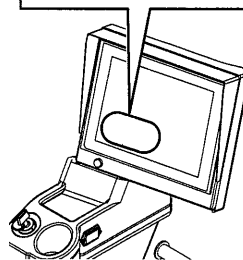
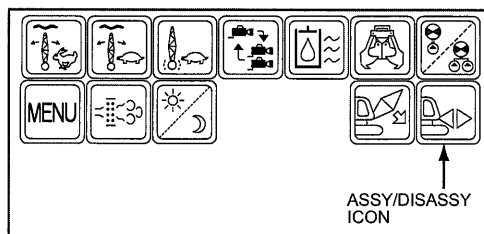

5.1.1 ARRANGEMENT OF BOOM/JIB/GUY LINE

1. Preparation of boom/jib/guy line

Preparation of boom/jib/guy line and steel blocking plate (Pillow wedge).

Prepare necessary parts.

(1) Boom and jib

Prepare the boom and jib following the arrangement chart.

Do not assemble the boom which is not shown in the arrangement chart.

Check the each boom and jib component for damage.

If damage is found, repair the damage at the designated service shop.

Item	In case of crane boom
The boom length in which the jib can be installed	27.4 m to 61.0 m (90' to 200')
The boom length in which the Aux. sheave can be installed	15.2 m to 67.1 m (50' to 220')

⚠ DANGER

Do not use damaged boom or jib component.

They may collapse and lead to an accident.

Failure to observe this precaution may result in a serious injury or loss of life.

(2) Guy line

Prepare the guy lines following the arrangement chart.

The diameter of the boom guy line is 34 mm (1-5/16 in.), and the diameter of the jib guy line is 22 mm (7/8 in.).

To identify each guy line, see the part number stamped on the connector. (last 5 digits)

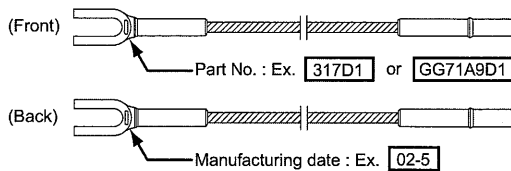

(3) Steel blocking plate

As for crane specification, when erecting of max. boom of 70.1 m (230 ft.), place the steel plates between the ends of the crawler and the ground.

For the combination of the boom of 61.0 m (200 ft.) length and the jib of any length, place steel plates between the ends of the crawlers and the ground.

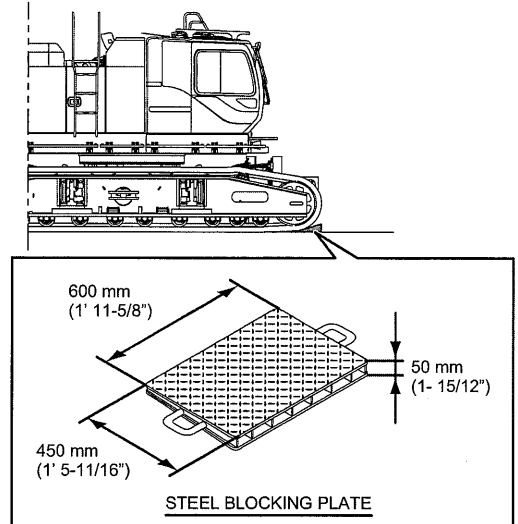

2. Boom and guy line arrangement

Note

Depending on the purchased configuration of boom, boom may not be able to arrange as shown on the chart.

The boom arrangement with the “★” is the preferred configuration.

Using the “★” arrangement will allow any shorter boom length to be assembled.

Shown below the “★” configurations are acceptable arrangement if required due to boom that was purchased.

Note

Actual lengths of boom section, wire rope are metric.

The values in () are approximate conversion to feet.

[5. ASSEMBLY/DISASSEMBLY OF CRANE ATTACHMENT]

Boom length : m (ft.)	Boom and guy line configuration	With Aux. sheave	With fixed jib	Max. parts of line		Boom self erecting at side direction
				Front drum	Rear drum	
15.2 (50)		○	×	10	2	○
18.3 (60)	*	○	×	9	2	○
21.3 (70)	*	○	×	8	2	○
24.4 (80)	*	○	×	7	2	○
27.4 (90)	*	○	○	6	2	○
30.5 (100)	*	○	○	6	2	○
33.5 (110)	*	○	○	6	2	○
36.6 (120)	*	○	○	5	2	○
39.6 (130)	*	○	○	4	2	○
42.7 (140)	*	○	○	4	2	○

○ : Allowed × : Not Allowed

Boom length : m (ft.)	Boom and guy line configuration	With Aux. sheave	With fixed jib	Max. parts of line		Boom self erecting at side direction
				Front drum	Rear drum	
45.7 (150)		○	○	4	2	○
48.8 (160)		○	○	3	2	○
51.8 (170)		○	○	3	2	○
54.9 (180)		○	○	3	2	○
57.9 (190)		○	○	3	2	○
61.0 (200)		○	○	2	2	○
64.0 (210)		○	×	2	2	○
67.1 (220)		○	×	2	2	×
70.1 (230)		×	×	2	-	×

○ : Allowed × : Not Allowed



5

- ↗ Mark shows the boom insert with lugs attached and the guy line installing position when the jib is used.
- * Mark shows the standard boom arrangement which make the boom arrangement of less than the each boom length possible.
- Mark shows the installing of the cable roller for the insert boom.

KIND OF BOOM INSERT

Symbol	Boom length	Specification
10	3.0 m (10')	Without lug
20	6.1 m (20')	Without lug
40	12.2 m (40')	Without lug
40A	12.2 m (40')	With lug

BOOM GUY LINE CHART

Symbol	Guy line dimension		Part number	Remarks : m (ft.)	Connector type
	Diameter : mm (in.)	Length : m (ft. in.)			
A	34 (1-5/16)	7.1 (23 3-1/2)	GK71A00005D1	Boom tip	
B	34 (1-5/16)	3.05 (10)	JJ71A00006D1	3.0 (10) Boom insert	
C	34 (1-5/16)	6.10 (20)	JJ71A00006D2	6.1 (20) Boom insert	
E	34 (1-5/16)	12.19(40)	JJ71A00006D4	12.2 (40) Boom insert	

ARRANGEMENT OF JIB AND GUY LINE

The length of the boom to which the jib can be attached is 27.4 m (90 ft.) to 61.0 m (200 ft.).

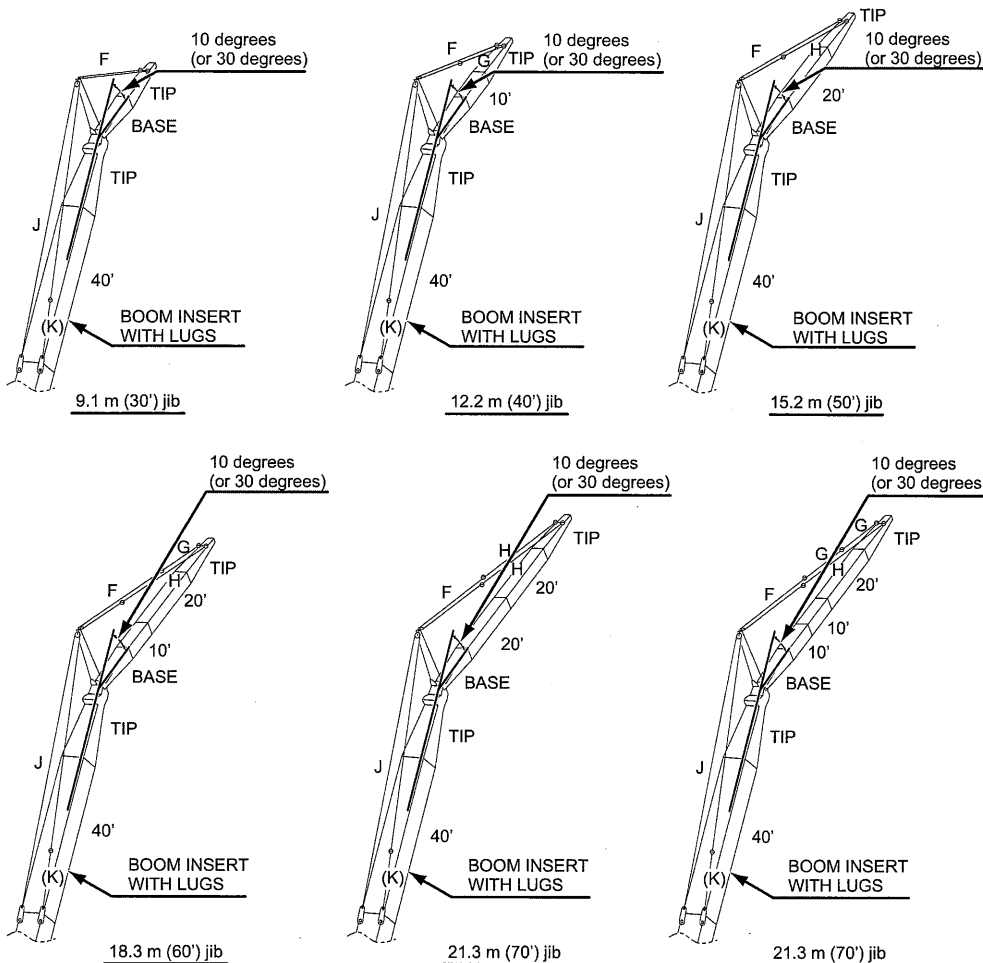

5

ARRANGEMENT OF GUY LINE IN BOOM SIDE

Offset angle	Boom arrangement
	(Boom tip + 12.2 m [40']) Arrangement
10 degrees	J
30 degrees	J + K

K : Additional guy line when the offset angle is 30 degrees

ARRANGEMENT OF GUY LINE IN JIB SIDE

9.1 m (30') Jib	12.2 m (40') Jib	15.2 m (50') Jib	18.3 m (60') Jib	21.3 m (70') Jib
F	F + G	F + H	G + F + H	H + F + H
				H + F + G + G

[5. ASSEMBLY/DISASSEMBLY OF CRANE ATTACHMENT]

KIND OF JIB INSERT

Symbol	Jib length	Specification
3.0	3.0 m (10')	Jib
6.1	6.1 m (20')	Jib

KIND OF GUY LINE

Symbol	Diameter : mm (in.)	Length m : (ft. in.)	Part No.	Connector type
J	22 (7/8)	40.0 (131 2-13/16)	2430R317D5	
K	22 (7/8)	2.44 (8 1/16)	2430R316D1	
F	22 (7/8)	19.34 (63 5-7/16)	2430R317D2	
G	22 (7/8)	5.88 (19 3-1/2)	2430R316D3	
H	22 (7/8)	11.75 (38 6-5/6)	2430R316D2	

COMBINATION OF CRANE BOOM AND JIB

Boom length : m (ft.)	Jib length : m (ft.)					Self erecting of boom with jib in side direction
	9.1 (30)	12.2 (40)	15.2 (50)	18.3 (60)	21.3 (70)	
27.4 (90)	○	○	○	○	○	○
30.5 (100)	○	○	○	○	○	○
33.5 (110)	○	○	○	○	○	○
36.6 (120)	○	○	○	○	○	○
39.6 (130)	○	○	○	○	○	○
42.7 (140)	○	○	○	○	○	○
45.7 (150)	○	○	○	○	○	○
48.8 (160)	○	○	○	○	○	○
51.8 (170)	○	○	○	○	○	○
54.9 (180)	○	○	○	○	○	○
57.9 (190)	○	○	○	○	○	×
61.0 (200)	○	○	○	○	○	×

○ : Allowed × : Not Allowed

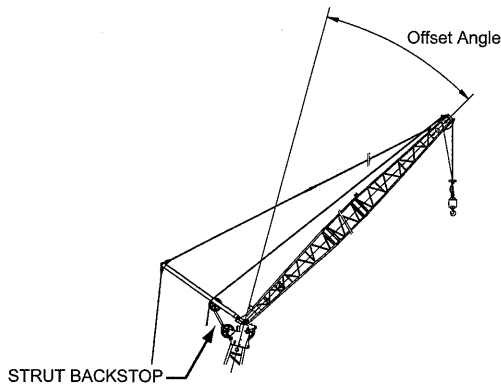

5.1.2 INSTALLING THE BOOM TIP

1. Hold the boom tip with the assist crane.

Align the top connectors of the boom tip with that of the boom base and tap the connecting pins (pin with flange) in, and insert the spring pin into the side of the connecting pins to fix them.

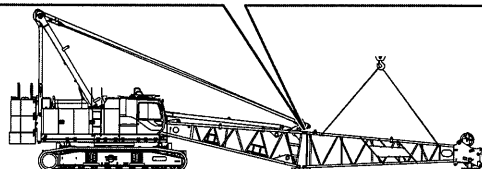
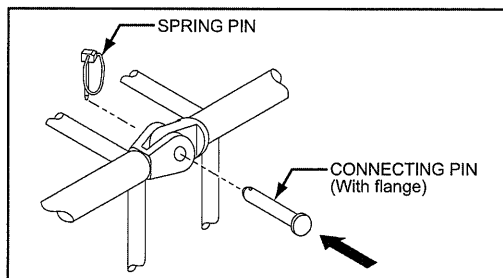

5

2. Raise the boom base until the lower pin holes are aligned with each other. Then tap the connecting pins (double tapered pin) in, and insert the spring pins into the both ends of the connecting pin.

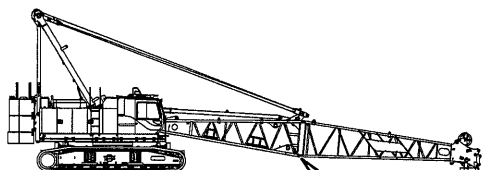

⚠ DANGER

Do not stand on, or enter under/inside of the boom/jib being connected or disconnected. Failure to observe these precautions may result in a serious injury or loss of life.

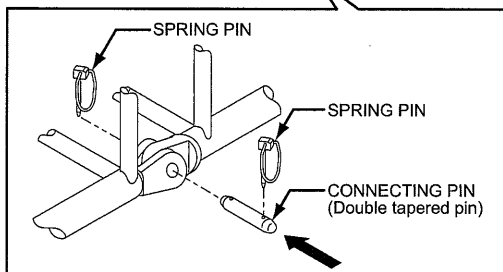

⚠ WARNING

Do not stand in line with the double tapered pins being inserted/removed. The pin may fly out from the pinhole. Failure to observe these precautions may result in a serious injury or loss of life.

5.1.3 INSTALLATION OF THE BASIC GUY LINE

⚠ WARNING

When working at an elevated location, watch your step and surroundings.

Utilize fall protection, walkway or aerial platform as needed.

Do not stand on component being connected or disconnected.

Failure to observe these precautions may result in a serious injury or loss of life.

1. Install the basic guy line to the boom tip and upper spreader.
Open the split pin of the guy line installing pins to approx. 60 degrees.
2. Remove the connecting pin on both side and disconnect the upper spreader from the top of boom base.
If needed, loosen the boom hoist wire rope to relief tension to the upper spreader.

⚠ WARNING

Do not insert finger or hand into a pin hole when aligning, inserting or removing pin.

Failure to observe this precaution may result in a serious injury or loss of life.

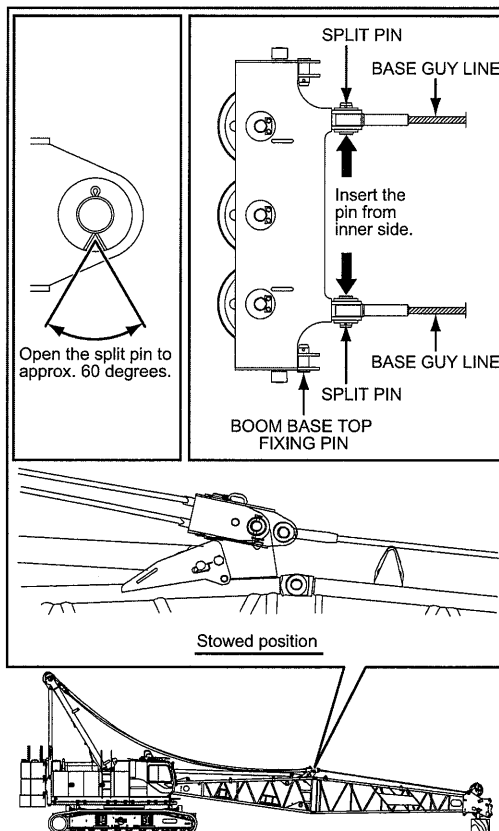

3. Turn the boom drum control lever to the raise side and wind the boom hoist wire rope slowly. During this operation, apply tension on the lower layer rope to prevent rope upsetting and tap the rope lightly with a hammer to make rope winding evenly. Stop winding the boom hoist wire rope just before the boom tip leaves the ground.

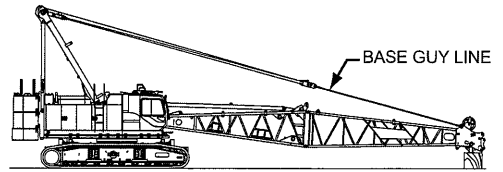

5.1.4 CONNECTING THE BOOM INSERT

This section covers the procedure to change the boom configuration from the basic boom to a longer boom.

1. Type of boom insert

There are four types of boom insert as follows.

Standard boom insert	Boom insert with lug
3.0 m (10')	—
6.1 m (20')	—
12.2 m (40')	12.2 m (40')

The boom insert with the lugs attached is needed in case as follows.

For the specification with jib.

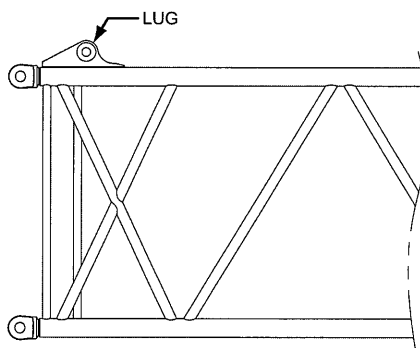

2. Winding up the front drum wire rope

Remove the rope socket from the wire rope, and wind up the wire rope onto the drum.

CAUTION

Do not touch a wire rope directly with bare hands. If wire protrude, you could be injured. Working gloves are recommended for protection. Keep away from rope end when removing the wire rope. It may suddenly jump and cause injury. Keep hands and clothing clear of the rotating drum and running wire rope. Failure to observe this precaution may result in a serious injury or loss of life.

3. Removing the boom tip section.

- (1) Lower the boom and install the upper spreader onto the top of the boom base with the use of spreader guide.
How to use spreader guide is shown in the next page.

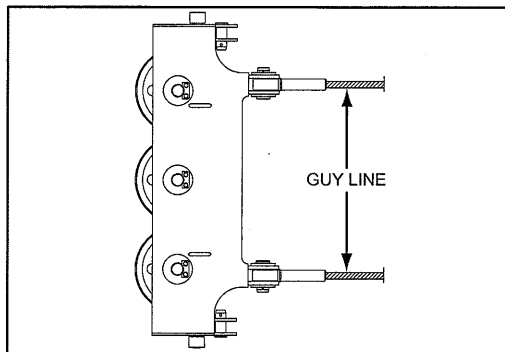

5

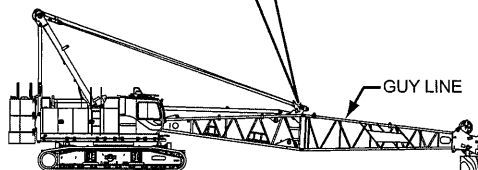

HOW TO USE SPREADER GUIDE

- (A) Draw out pin (a) and change the spreader guide from the stowed position to the assembly/disassembly position.
Then put back the pin (a) to the original position.

WARNING

Be sure to support the spreader guide with hands, when removing the pin and handling the guide. Failure to observe this precaution may result in serious injuries or loss of life.

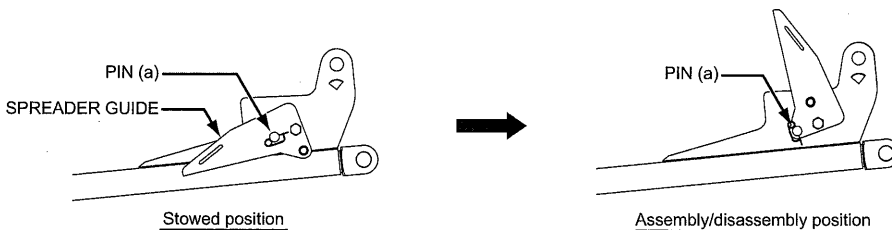

(B) Lower the boom.

After the tip end of the boom has been grounded, slowly loosen the boom hoist wire rope more.

The spreader is lowered along the spreader guide.

When the hole of the spreader is aligned with the pin hole of the bracket on the boom base section, insert pin (b) to connect the spreader to the base boom bracket.

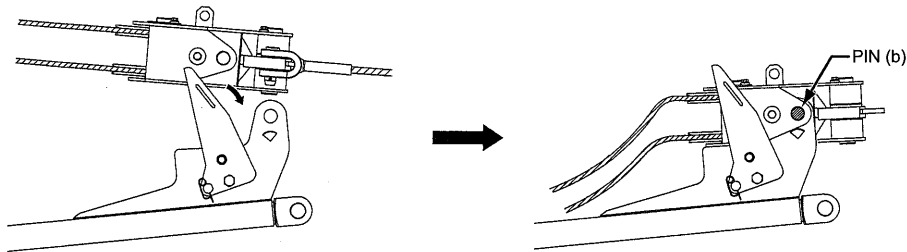

⚠ WARNING

Do not insert finger or hand into a pin hole when aligning, inserting or removing pin.

Failure to observe this precaution may result in a serious injury or loss of life.

- (C) When stowing the spreader guide, slowly tighten the boom hoist wire rope.

When there is a clearance between the spreader and the guide, draw out pin (a), and return the guide to the stowed position.

Note

Since the clearance would not be made with boom base section only, perform this start the boom disassembly.

CAUTION

When the gantry is in the lowered condition, be sure to set the spreader guide in the stowed position.

If left in the assembly/disassembly position, the guide could be damaged when raising the boom.

When the gantry is lowered and the upper spreader is connected to the boom base, set the spreader guide in the stowed position.

At this time, do not raise the boom higher than 20 degrees.

If the boom is raised beyond 20 degrees, the boom hoist rope may be damaged.

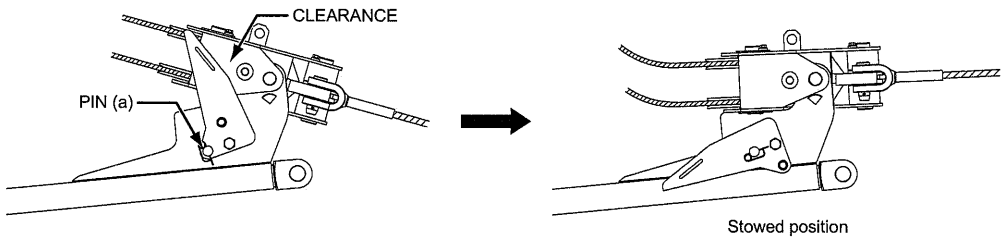

WARNING

Be sure to support the guide with hands, when removing the pin and handling the guide.

Failure to observe this precaution may result in a serious injuries or loss of life.

- (D) After change of the boom connection or assembly has been finished, draw out pin (b), and wind up the boom hoist wire rope slowly so that the spreader slides up slowly on the guide.

If the spreader is raised up fast, the spreader maybe be caught against the spreader guide and damage it.

If caught, loose the wire rope once, then intermittently operate the boom drum to the raise side to correct it.

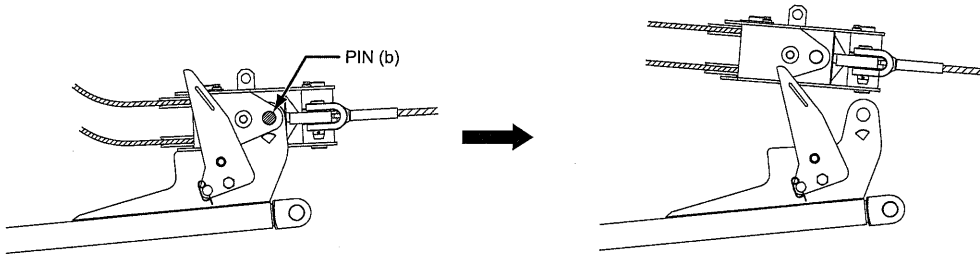

- (E) Return the spreader guide to the stowed position.
- (F) After the boom connection is completed, tighten the boom hoist wire rope, and set the spreader guide to the assembly/disassembly position.

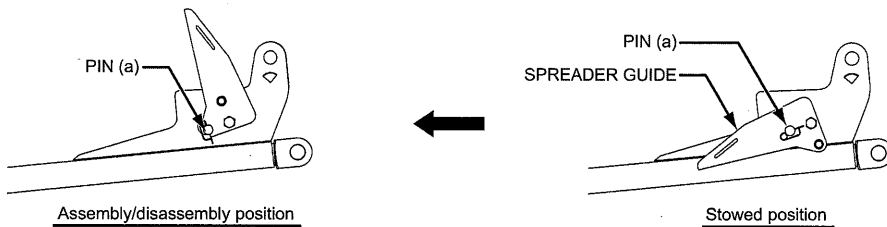

⚠ WARNING

Be sure to support the spreader guide with hands, when removing the pin and handling the guide. Failure to observe this precaution may result in a serious injuries or loss of life.

- (2) By following the procedure (B) in “HOW TO USE SPREADER GUIDE” connect the spreader and the boom base bracket with the pin (b). Then remove the guy line connecting pin and remove the base guy line from the upper spreader.

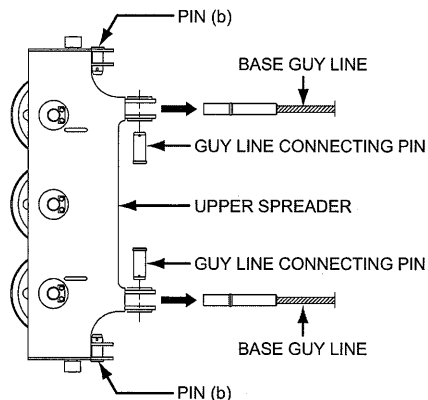

- (3) Operate the boom hoist control lever to tighten the boom hoist wire rope to remove load from the bottom connector section, then draw out the bottom connecting pins (with a suitable tool).

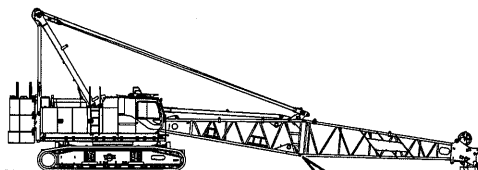

⚠ DANGER

Do not stand or work under, inside or on the boom structure when removing the connecting pins. Failure to observe this precaution may result in a serious injuries or loss of life.

⚠ WARNING

Do not stand in line with the double tapered pins being inserted/removed. The pin may fly out from the pinhole. Failure to observe these precautions may result in a serious injury or loss of life.

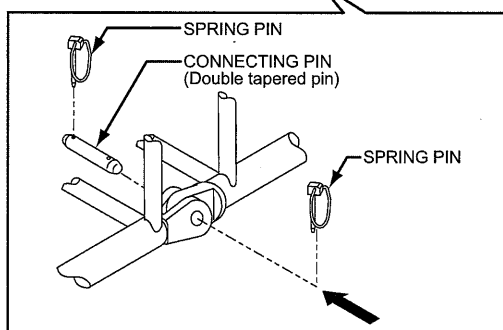

⚠ WARNING

Do not insert finger or hand into a pin hole when aligning, inserting or removing pin. Failure to observe this precaution may result in a serious injury or loss of life.

- (4) Hold the boom tip with the assist crane.
Place blocking under the boom tip section and lower the boom base section.
Then draw out the top connecting pins.

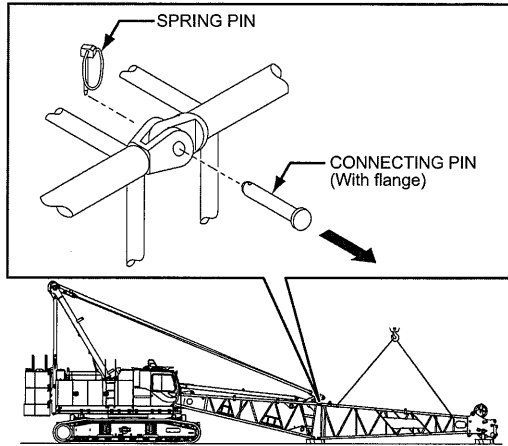

⚠ DANGER

Do not stand on, or enter under/inside of the boom/jib being connected or disconnected.
Failure to observe these precautions may result in a serious injury or loss of life.

4. Connecting the boom insert

For the cautions on the cantilever support, refer to P.5-30.

- (1) Referring to the boom and guy line configuration chart, prepare the required boom components, careful on top/bottom sides, and place near the boom base section.

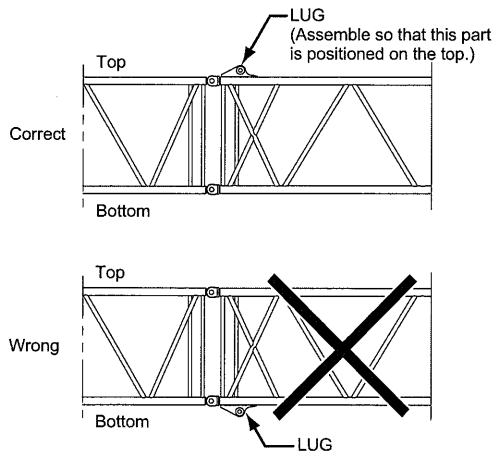

⚠ DANGER

Do not stand on, or enter under/inside of the boom/jib being connected or disconnected.
Failure to observe these precautions may result in a serious injury or loss of life.

⚠ CAUTION

When assembling or disassembling the boom, place wood blockings on the ground where the boom is placed to prevent it from contacting directly on the ground.

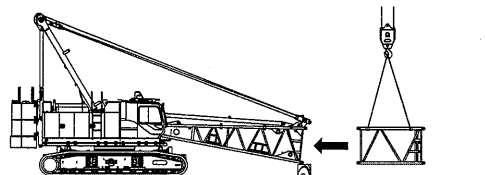

- (2) Align the top connecting pin holes of the boom base and insert the right and left connecting pins (pin with flange) with the lock pinholes facing up and down. Insert the spring pins to fix the connecting pins.

⚠ WARNING

Do not insert finger or hand into a pin hole when aligning, inserting or removing pin.
Failure to observe this precaution may result in a serious injury or loss of life.

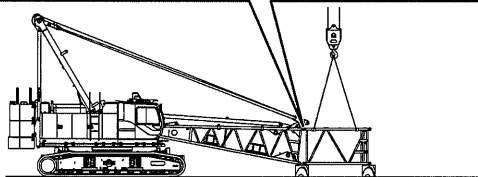
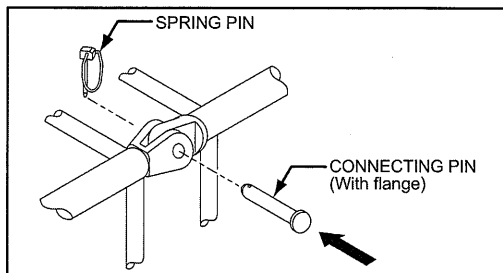

- (3) Lift up the connecting section of the boom base and the boom insert, align the pin holes, and insert the connecting pins (double tapered pin) into the holes.
Insert the spring pins into the connecting pins to secure them.

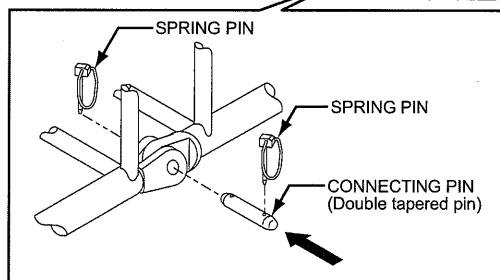
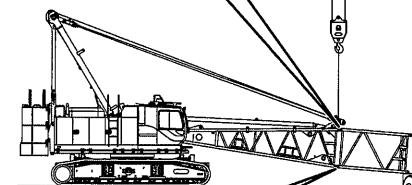
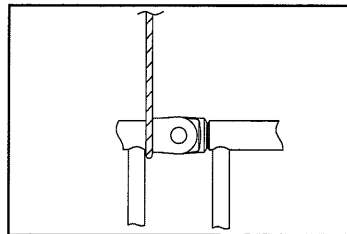

⚠ DANGER

Do not stand under the boom or inside the boom structure when removing connecting pins.
Failure to observe this precaution may result in a serious injuries or loss of life.

⚠ WARNING

When working at an elevated location, watch your step and surroundings.
Utilize fall protection, walkway or aerial platform as needed.
Do not stand on component being connected or disconnected.
Failure to observe these precautions may result in a serious injury or loss of life.

⚠ WARNING

Do not stand in line with the double tapered pins being inserted/removed.
The pin may fly out from the pinhole.
Failure to observe these precautions may result in a serious injury or loss of life.

⚠ WARNING

Do not insert finger or hand into a pin hole when aligning, inserting or removing pin.
Failure to observe this precaution may result in a serious injury or loss of life.

- (4) Referring to Boom and guy line arrangement chart, connect the boom inserts in order in the same way.
 Refer to P.5-30.
 When assembling the booms.

Note

Ensure to drive in the pin with flange from outside to inside.

⚠ DANGER

Do not exceed the cantilever limitation.
 Failure to observe this precaution may result in a serious injury or loss of life.

⚠ WARNING

Do not insert finger or hand into a pin hole when aligning, inserting or removing pin.
 Failure to observe this precaution may result in a serious injury or loss of life.

⚠ CAUTION

When assembling or disassembling the boom, place wood blockings on the ground where the boom is placed to prevent it from contacting directly on the ground.

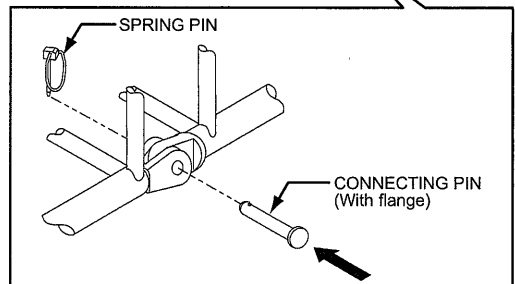
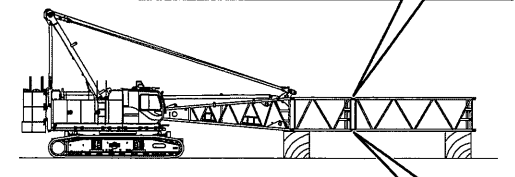
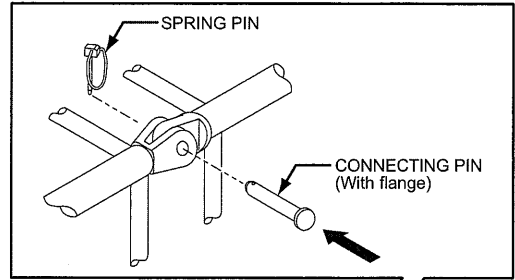

5. Installing the boom tip

Lift up the boom tip and connect it to the boom insert with the connecting pins (with flange).

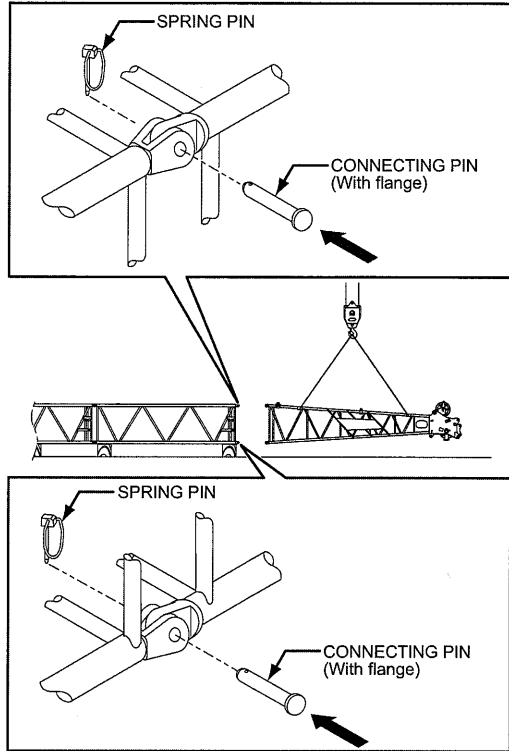

Another way of connecting the attachment is to connect the boom inserts and the boom tip first then connect them with the boom base at last.

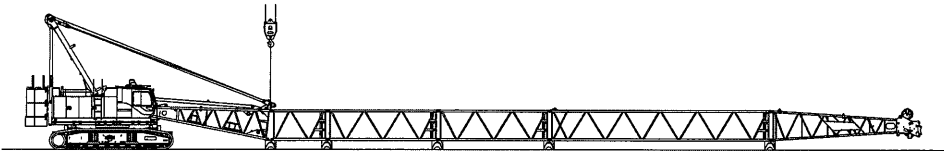

WARNING

Do not insert finger or hand into a pin hole when aligning, inserting or removing pin.
Failure to observe this precaution may result in a serious injury or loss of life.

5.1.5 INSTALLING THE CABLE ROLLERS

Install the cable rollers to the location as shown in the boom configuration chart.

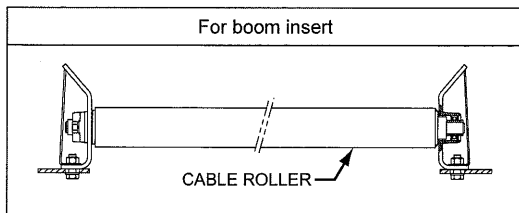

5.1.6 CONNECTING THE BOOM GUY LINES

1. Prepare guy line according to the guy line configuration chart.

Insert the guy line connecting pin from the inside.

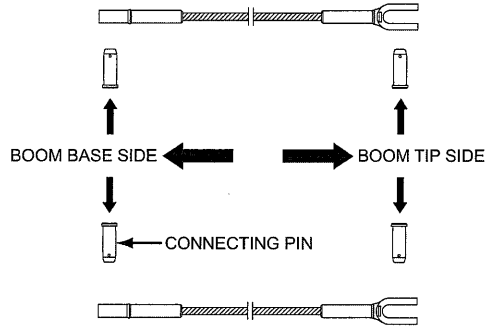

2. Connect the prepared guy lines starting at the boom tip side to the basic machine side one by one.

Do not leave slack on the guy line.

If the guy line is loose the end may not reach the upper spreader.

⚠ WARNING

When working at an elevated location, watch your step and surroundings.

Utilize fall protection, walkway or aerial platform as needed.

Do not stand on component being connected or disconnected.

Failure to observe these precautions may result in a serious injury or loss of life.

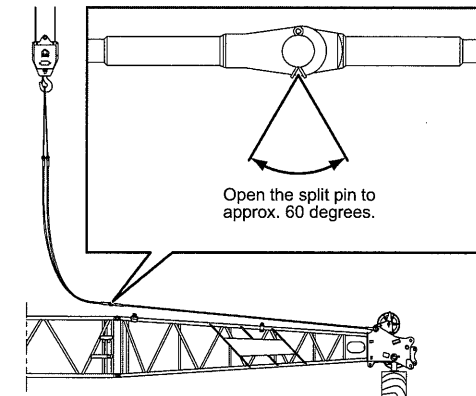
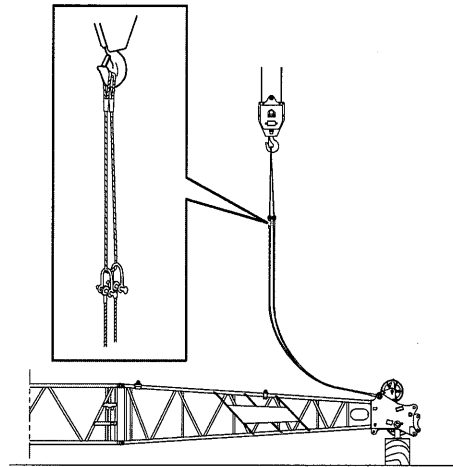

3. Connect the guy line to the upper spreader.
4. Loosen the boom hoist wire rope to relieve tension.

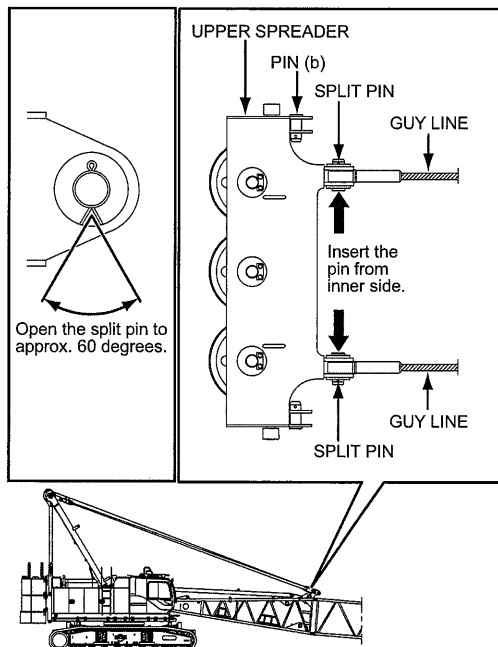

5

5. Use the spreader guide to remove the pin (b).

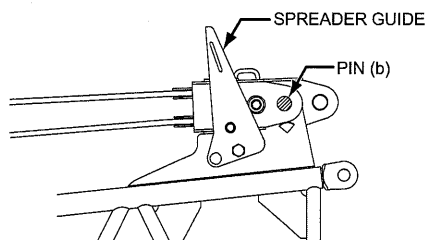

6. Wind up the boom hoist rope.
Pay attention not making rough spooling on the drum.

WARNING

**Place a signal person to prevent accident from moving machinery or running ropes.
Failure to observe this precaution may result in a serious accident or injury.**

5.1.7 CAUTION FOR CANTILEVER

1. Support with boom base

CAUTION

Be sure to confirm that gantry is set at "WORK" position.

Do not exceed the length of cantilever mentioned.
Operate crane at the slowest speed as possible.

(1)	With boom tip	36.6 m (120') and shorter
(2)	With Aux. sheave	33.5 m (110') and shorter
(3)	With boom insert only	41.1 m (135') and shorter

For the details of connection of the boom insert, refer to the article "5.1.4 CONNECTING THE BOOM INSERT".

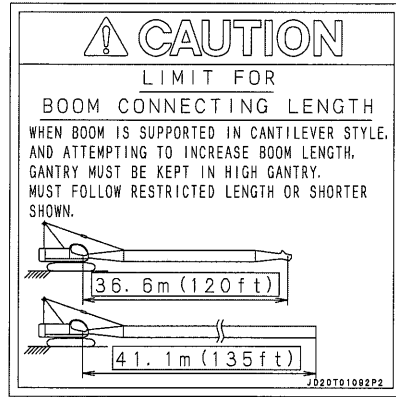

JD20T01092P2

DANGER

Do not perform the hoisting work or propel while the boom is supported with the cantilever.

Failure to observe this precaution may result in a serious injuries or loss of life.

CAUTION

Be sure to confirm that gantry is set at "WORK" position.

Do not exceed the length of cantilever mentioned.
Operate crane at the slowest speed as possible.

DANGER

Do not perform the hoisting work or propel while the boom is supported with the cantilever.

Failure to observe this precaution may result in a serious injuries or loss of life.

5.1.8 FRONT DRUM WIRE ROPE REEVING

⚠ CAUTION

Install the hook block in the correct direction which the striker is located at the machine side and the striker pins will hit to a weight for overhoist limit switch.

⚠ WARNING

Place a signal person to prevent accident from moving machinery or running ropes.
Failure to observe this precaution may result in a serious accident or injury.

⚠ WARNING

Do not handle wire rope with bare hands.
Use hand protection.
Pay attention to the running rope to prevent being caught.
Failure to observe these precautions may result in serious injuries or loss of life.

1. Prepare the hook, overhoist limit switch, weight and socket, etc. to be used near the tip end of the boom.
2. Turn the front drum control lever to the lowering side to pay out the wire rope to the tip end of the boom and pass it through the right idler sheave and to the right of the boom point.

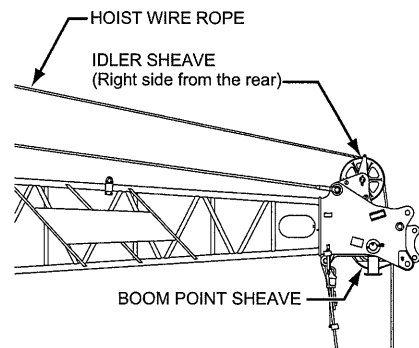

3. Install the hook overhoist limit switch and weight to the boom tip's left side bracket.
Insert the split pin into the shackle pin to secure it.

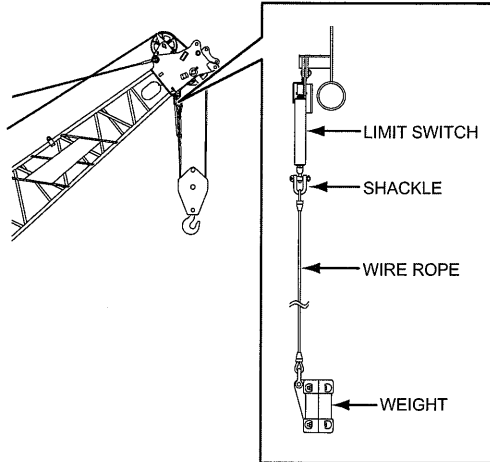

4. Reeve the front drum wire rope through the hook and boom point sheaves in order.
Be sure to put the wire rope through the weight for the hook overhoist limit switch.
Terminate the wire rope end with the rope socket to the boom point for even number, and to the hook for odd number of parts of line.

HOIST ROPE REEVING IN BOOM POINT AREA

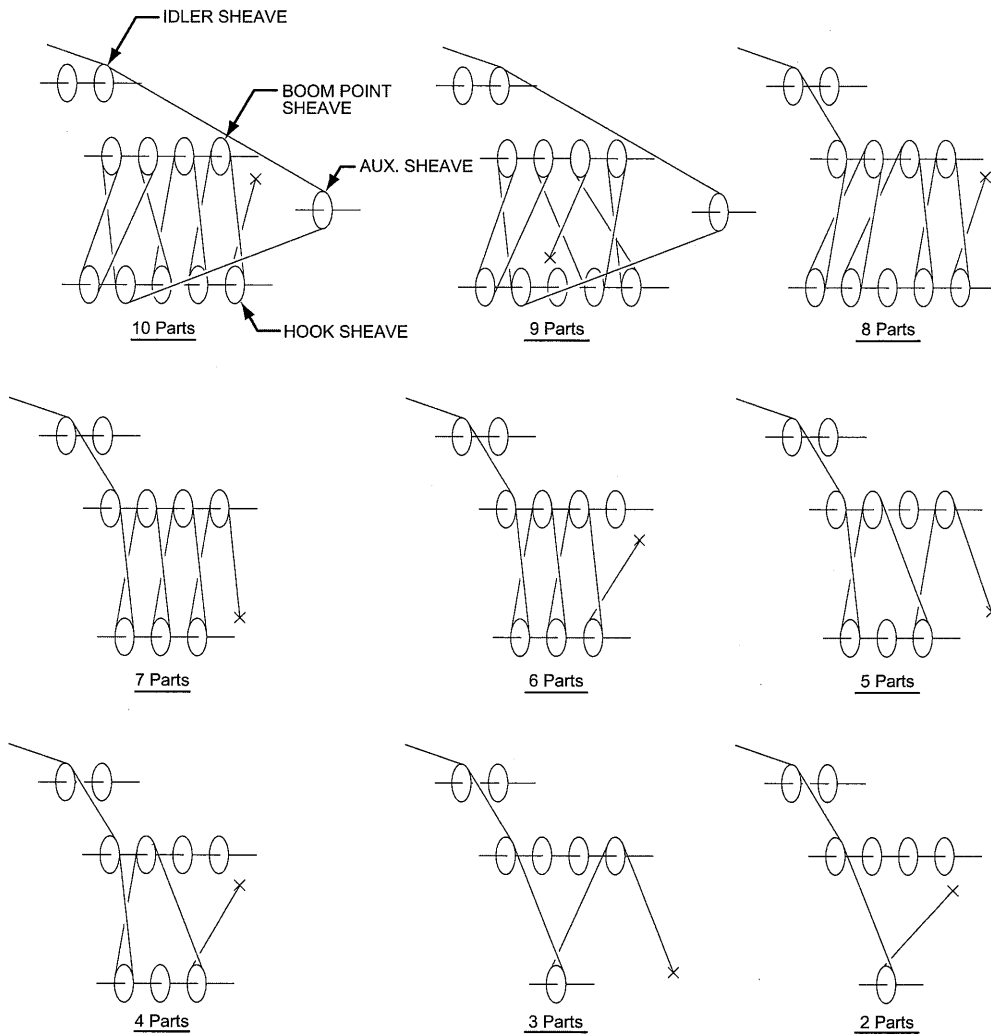

(This figure is view from the boom tip side.)

HOOK INSTALLING DIRECTION

When reeving the hoist wire rope to the hook, face the striker (hook side weight catch) contacting the hook overhoist limit switch weight to the boom foot side.

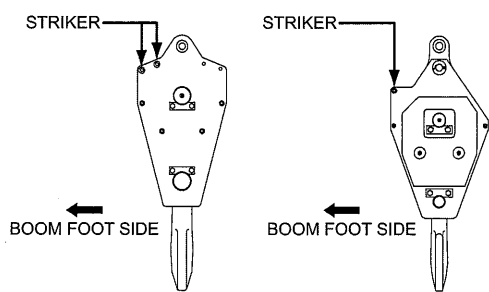

When installing the rope socket to the boom point, pay attention on the side of rope socket. Be sure to pass the wire rope through the hook overhoist limit switch weight.

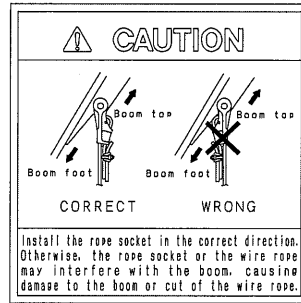
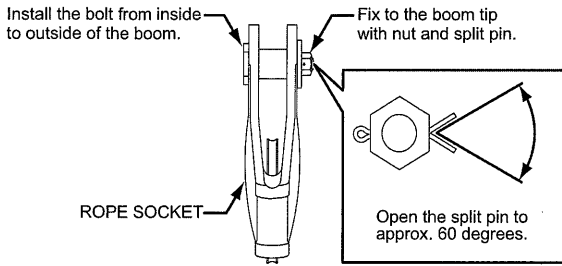

5. Load safety device connection

- (A) Secure the junction cables or limit switch wiring to the boom with the hanger.
- (B) Connect the attachment wiring to the main machinery junction panel.
- (C) Check the connection of load detector connector. (boom hoist winch plate area)
- (D) Connect the cable reel wiring to the boom tip junction box.
- (E) Connect the hook overhoist cable reel connector.
- (F) Check the connection of hook overhoist limit switch wiring to the boom tip junction box.
- (G) If needed, place steel blocking plate at the front end the crawlers.

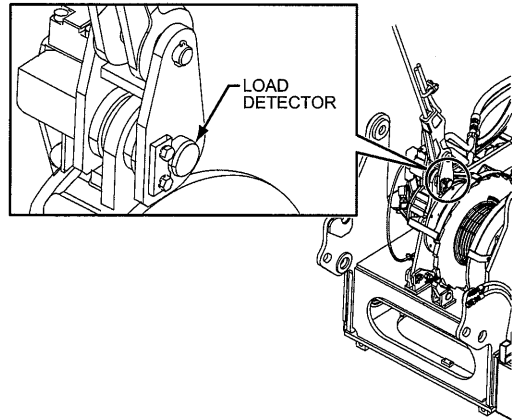

If the jib and the Aux. sheave are not installed, connect the hook overhoist limit switch wiring at this time. As for detail of wiring connection, refer to the article 3 "CONNECTING PROCEDURE OF WIRING".

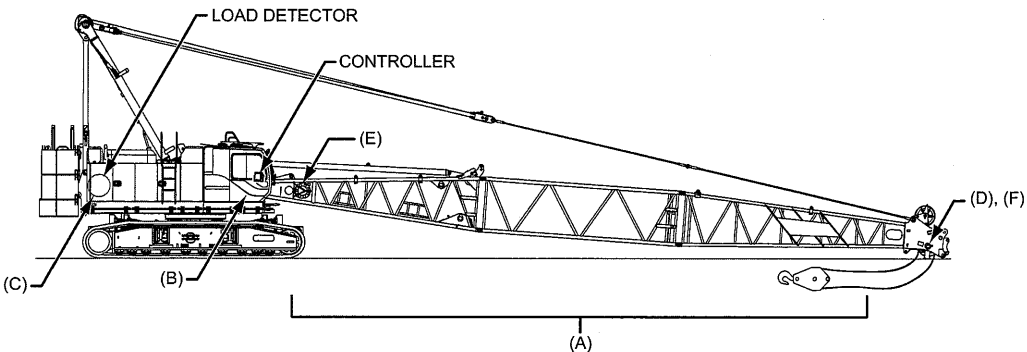

6. Refer to the article 3 "LOAD SAFETY DEVICE", input the crane configuration data in the load safety device.

⚠ DANGER

**Input the crane configuration properly to prevent machine overturn or damage.
Failure to observe this precaution may result in a serious accident.**

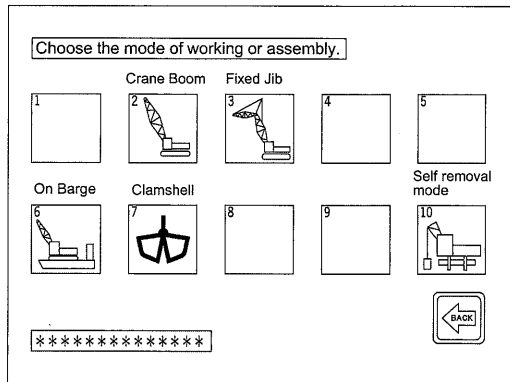

Monitor screen

5

Type	Type of overhoist	Type of stop	Auto-stop angle
Crane	Boom overhoist	Controller (against ground angle)	78.0 to 81.4 degrees
		Limit switch (against machine angle)	83.5 to 84.5 degrees
	Self removal	Controller (against ground angle)	86 degrees
		Limit switch (against machine angle)	Approx. 86.5 degrees

5.1.9 ASSEMBLING THE JIB

When the jib is not installed, proceed to "5.1.11 INSTALLING THE AUXILIARY SHEAVE".

For the jib and jib guy line configuration, refer to P.5-11.

⚠ DANGER

Do not stand on, or enter under/inside of the boom/jib being connected or disconnected. Failure to observe these precautions may result in a serious injury or loss of life.

The boom length in which the jib can be installed is 27.4 m (90 ft.) to 61.0 m (200 ft.).

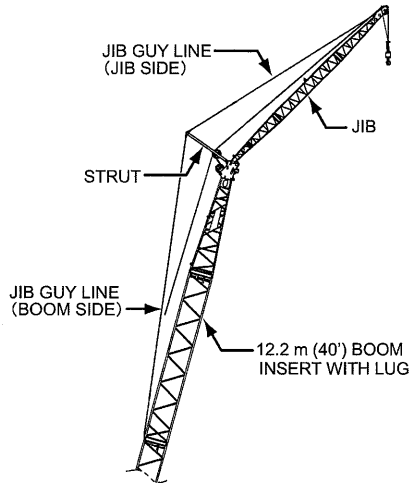

Boom length : m (ft.)	Jib length : m (ft.)				
	9.1 (30)	12.2 (40)	15.2 (50)	18.3 (60)	21.3 (70)
27.4 (90)	○	○	○	○	○
30.5 (100)	○	○	○	○	○
33.5 (110)	○	○	○	○	○
36.6 (120)	○	○	○	○	○
39.6 (130)	○	○	○	○	○
42.7 (140)	○	○	○	○	○
45.7 (150)	○	○	○	○	○
48.8 (160)	○	○	○	○	○
51.8 (170)	○	○	○	○	○
54.9 (180)	○	○	○	○	○
57.9 (190)	○	○	○	○	○
61.0 (200)	○	○	○	○	○

○ : Allowed × : Not allowed

1. Place the assembled jib and strut on the extension line of the boom tip.
Place on wood blocks.
Install cable roller at designated locations.
The use pins with flange for jib connections.

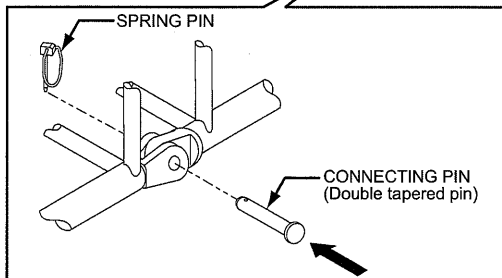
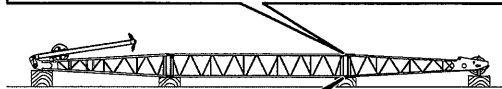
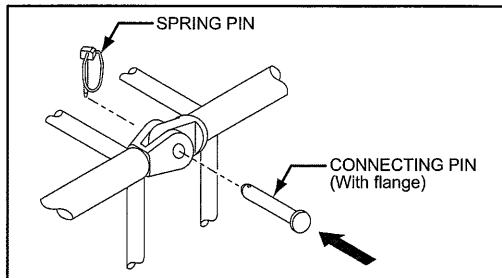

2. Lift up the pre-assembled jib with an assist crane connect it to the boom point.

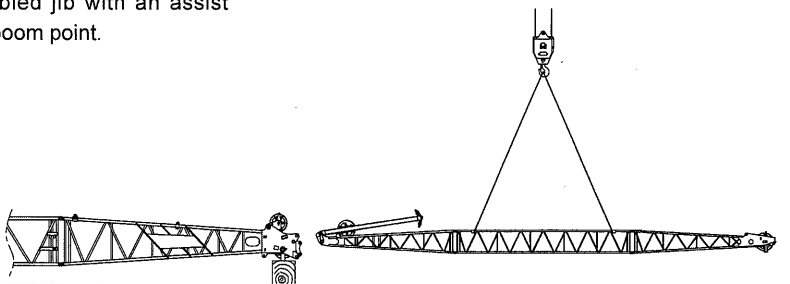

5

3. Prepare the jib guy lines.
(The jib side and boom side)

Insert the guy line connecting pins from outside.

- The length of the jib guy line of the jib side varies according to the jib length.
- The length of the jib guy line of the boom side varies according to the jib offset angle (10 degrees or 30 degrees) and the boom insert length (6.1 m [20 ft.] or 9.1 m [30 ft.]) connected to the boom tip.

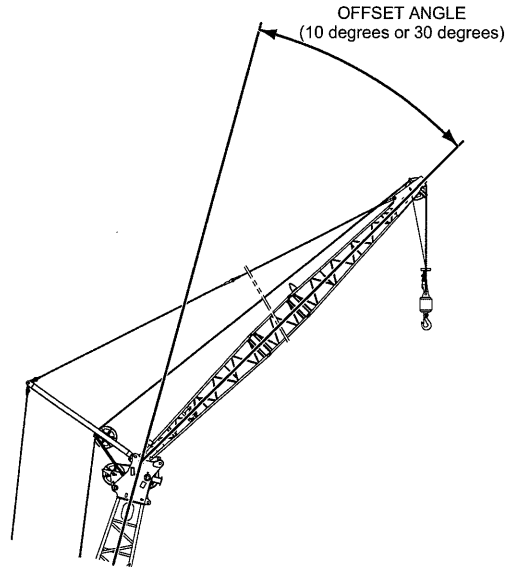

4. Temporarily remove the equalizer sheave of the jib strut, and put the jib guy line through the sheave.
Reinstall the sheave back to the original position.
(keep the strut down.)

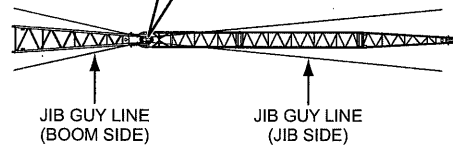
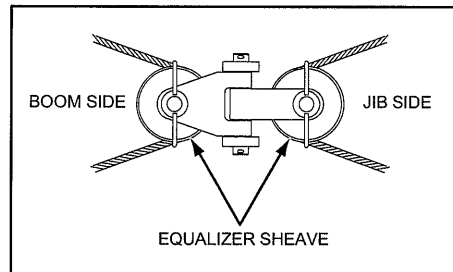

Note

Perform this work with multiple persons.

- Connect both end of the jib guy line to the top end of the jib.

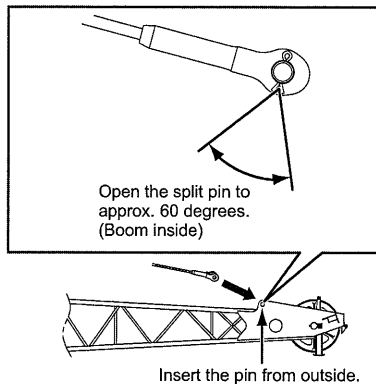

5

- Raise the strut with the assist crane and install the strut backstop.

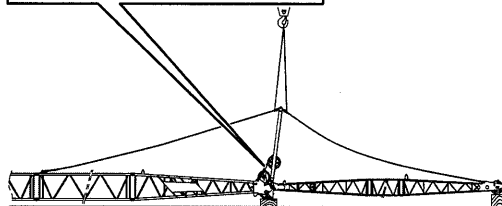
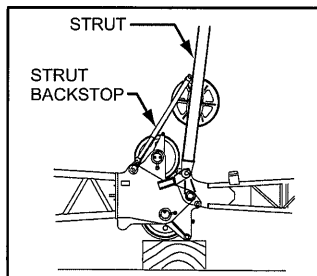

- By holding the jib strut, connect the both ends of the boom side jib guy line to the lug on the boom insert.
The guy line connection pins must be inserted from outside to inside and be secured with the split pins .
Open the split pins to approx. 60 degrees.

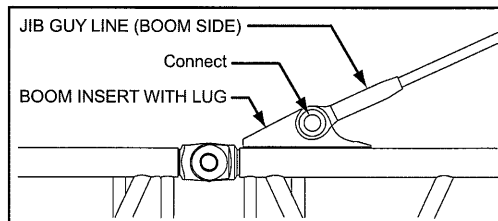

- Remove the sling wire rope from the jib strut.

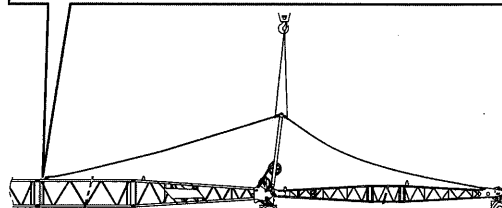

WARNING

After the assembly has been completed, be sure to confirm that all connecting pins and lock pins are correctly installed.
Failure to observe this precaution may result in a serious injury or loss of life.

5.1.10 REEVING OF REAR DRUM WIRE ROPE

⚠ WARNING

Do not touch a wire rope directly with bare hands.
If wire protrude, you could be injured.
Use protection.
Keep away from rope end when removing the wire rope.
If may suddenly jump and cause injury.
Keep hands and clothing clear of the rotating drum and running rope.
Failure to observe this precaution may result in a serious injury or loss of life.

1. Place the hook block near the tip end of the jib.
2. Turn the rear drum control lever to lower side to pay out the wire rope to put through the idler sheave at the strut and pass it to the jib point sheave.
3. Install the hook overhoist limit switch and weight to the jib point section.

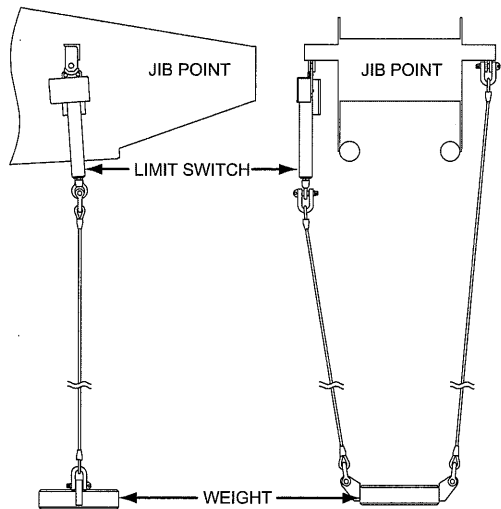
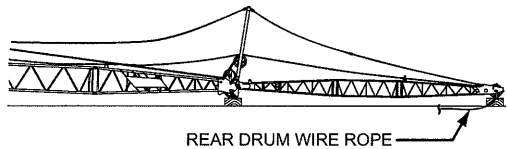

4. Pass the wire rope end through the weight for the limit switch, and secure the end to the hook rope socket with the bolt, nut and split pin.

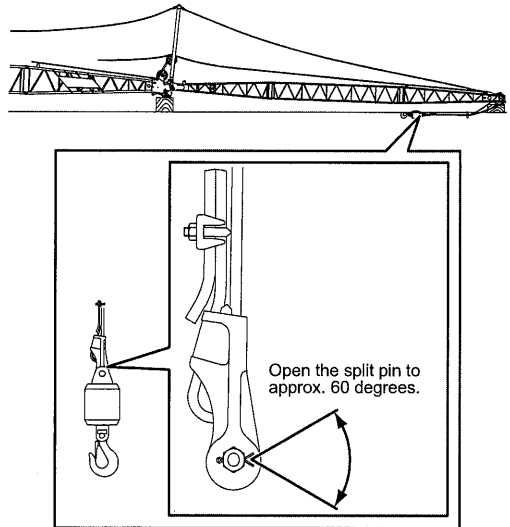

5

5. Refer to the article 3 "LOAD SAFETY DEVICE", connect the wiring for the auxiliary hoist hook anti-two block (overhoist) limit switch.

WARNING

After the assembly has been completed, be sure to confirm that all connecting pins and lock pins are correctly installed.

Failure to observe this precaution may result in a serious injury or loss of life.

6. Connecting the load safety device
 - Connect the jib cable reel wiring to the top of the boom tip wiring and to the hook overhoist limit switch wiring.
 - Connect the jib angle meter wiring to the boom tip junction box.

For detail of wiring connection, refer to the article 3 "CONNECTING PROCEDURE OF WIRING".

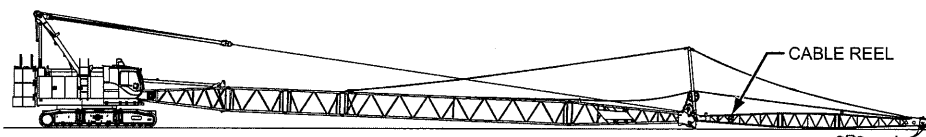

7. Refer to the article 3 "LOAD SAFETY DEVICE", input the crane configuration data in the load safety device.

⚠ DANGER

**Do not set wrong crane configuration.
Failure to observe this precaution may result in a serious accident.**

⚠ CAUTION

Check the function of the anti-two-block alarm system.

⚠ DANGER

**Input the crane configuration properly to prevent machine overturning or damage.
Failure to observe this precaution may result in a serious accident.**

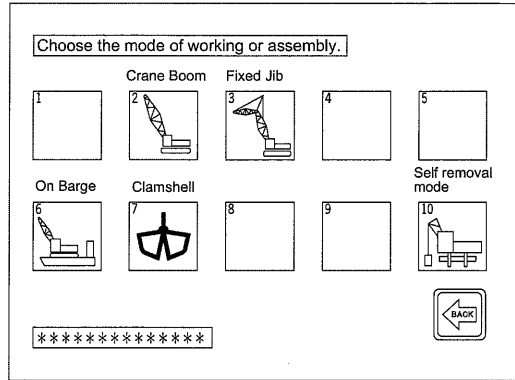

Monitor screen

5.1.11 INSTALLING THE AUXILIARY SHEAVE

The boom length to which the auxiliary sheave can be installed is 15.2 m (50 ft.) to 67.1 m (220 ft.).

Auxiliary sheave weight : 300 kg (660 lbs)

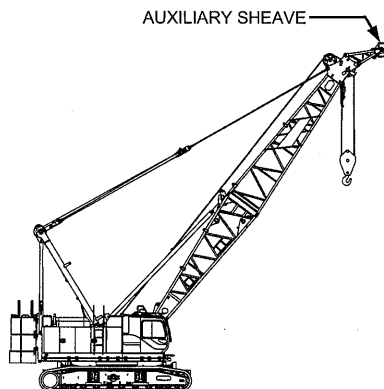

5

Lift the auxiliary sheave with the assist crane.

Secure it to the boom top with the pins and lock them with spring pins (2 positions, both upper and lower sides).

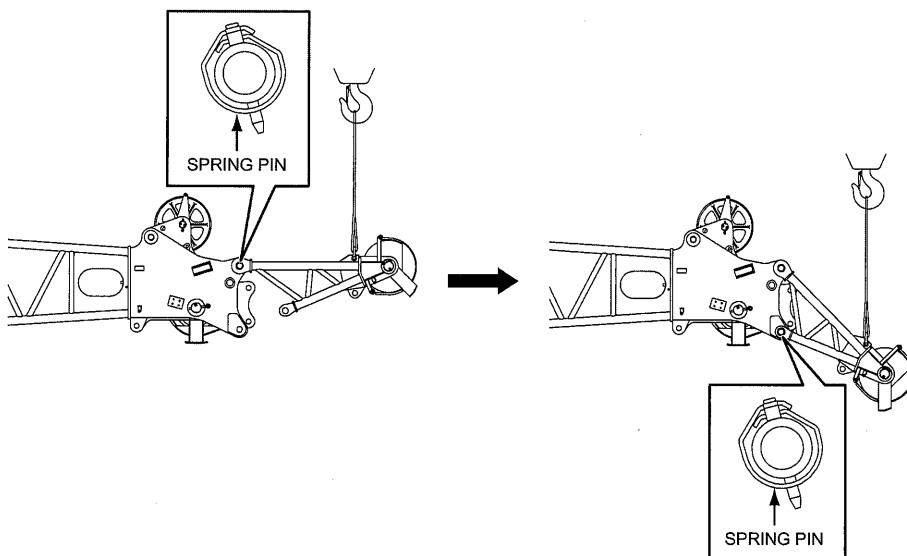

WARNING

Do not insert finger or hand into a pin hole when aligning, inserting or removing pin.

Failure to observe this precaution may result in a serious injury or loss of life.

5.1.12 REEVING THE REAR DRUM WIRE ROPE TO THE AUXILIARY SHEAVE

⚠ WARNING

Do not touch a wire rope directly with bare hands.
 If wire protrude, you could be injured.
 Use protection.
 Keep away from rope end when removing the wire rope.
 It may suddenly jump and cause injury.
 Keep hands and clothing clear of the rotating drum and running rope.
 Failure to observe this precaution may result in a serious injury or loss of life.

1. Place the hook block near the tip of the auxiliary sheave.
2. Turn the rear drum control lever to lower side to pay out the wire rope to put through the idler sheave at the boom tip and pass it to the auxiliary sheave.
3. Install the overhoist limit switch and weight to the auxiliary sheave.
4. Pass the wire rope through the weight for the hook overhoist limit switch, and secure the rope end to the ball hook with a rope socket.

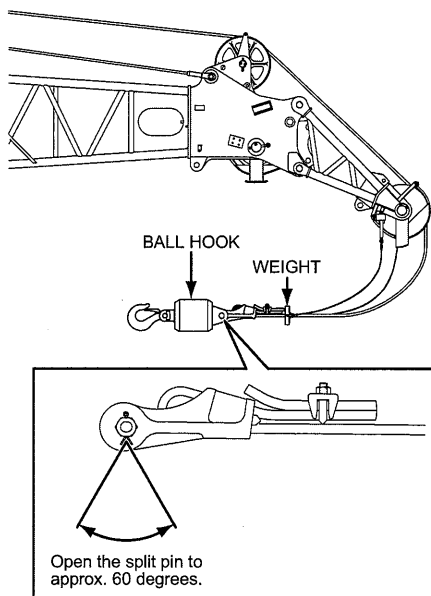

5. Connecting the load safety device

Connect the Aux. sheave frame wiring to the boom top wiring and overhoist limit switch wiring.

For detail of wiring connection, refer to the article 3 "CONNECTING PROCEDURE OF WIRING".

6. Refer to the article 3 "LOAD SAFETY DEVICE", input the crane configuration data in the load safety device.



Input the crane configuration properly to prevent machine overturning or damage. Failure to observe this precaution may result in a serious accident.

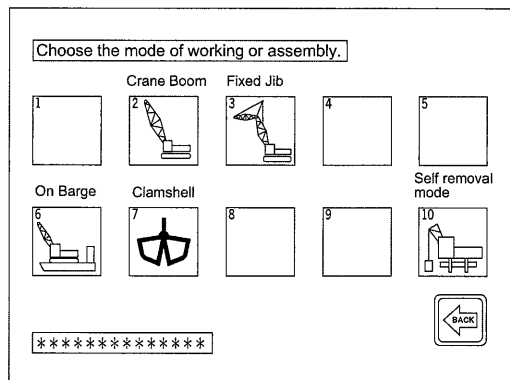

Monitor screen

5.1.13 FUNCTION CHECK OF EACH LIMIT SWITCH



Return levers to the neutral positions, and check safety around the machine before starting the engine.

Failure to observe this precaution may result in a serious accident.

1. Start the engine.
2. Check the function of the limit switch for the main auxiliary hook overhoist and boom overhoist.

For the detail of checking method, refer to the article 3 "LOAD SAFETY DEVICE" .

If any of overhoist limit switch or striker shows damage, deformation, looseness, or deviated from angle indication or parts replaced, readjustment is necessary.

Contact authorized KOBELCO service provider.

5.2 ERECTING THE ATTACHMENT

5.2.1 CONFIRMATION BEFORE ERECTING THE ATTACHMENT

Check the following items, and confirm that there is no abnormality, then erect the boom.

- (1) Preoperational check completed.
- (2) Lubrication to the required part of the attachment performed.
- (3) Crawlers are in fully extended position. (unless authorized)
- (4) Wire ropes correctly roved.
- (5) No tools or articles left on the attachment.
- (6) Off limit signs posted at surrounding area of the attachment.
- (7) Wiring for the boom, main and auxiliary hook overhoist limit switches properly connected.
- (8) Limit switch (es) functions.
- (9) Load safety device correctly wired.
- (10) Proper crane configuration data set.
Proper hook mode selected.
- (11) Propel motor set to rear side.
- (12) For the combination of the boom of 61.0 m (200 ft.) length and the jib of any length, place end blocking plates at front ends of the crawlers.
- (13) When the crane boom length is 70.1 m (230 ft.), place end blocking plates at front ends of the crawlers.

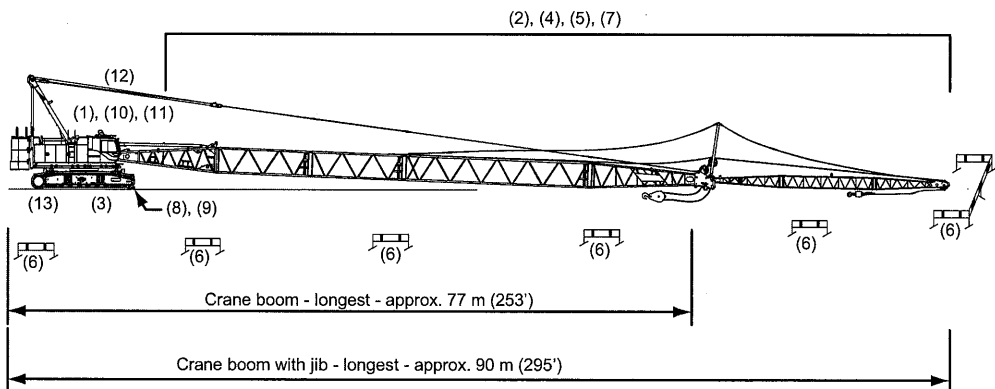

5.2.2 ERECTING THE ATTACHMENT

 **DANGER**

Do not stand or work under, inside or on the boom structure to prevent accident due to sudden fall of the attachment.

Failure to observe this precaution may result in a serious injuries or loss of life.

 **WARNING**

To prevent from being dragged or struck by sudden moving hook, stay off from the hook when the attachment is erected.

Failure to observe this precaution may result in a serious injury or loss of life.

1. Cautions when erecting
 - (1) Erecting of the attachment must be performed in the front and rear direction of the crawlers.
 - (2) When the boom angle is less than 20 degrees, place the hook on the ground.
(However, when a jib attachment with the boom of 51.8 m [170 ft.] or longer, place the hook on the ground for the boom angle less than 30 degrees.)
 - (3) Operation must be performed at a low speed. Sudden movement must be avoided.
 - (4) Prevent the wire rope from catching and kink in the tip of the boom and jib.
2. Release the drum lock(s) on which the hook is attached.
3. Operate the boom hoist control lever toward the RAISING side to raise the boom slowly.
4. Paying close attention to catching and kink of the hoist wire rope, raise the hook.

5. Before starting actual work, confirm the following items.

- (1) When the hook is raised to strike against the weight of the hook overhoist limit switch, the raising motion must be auto-stopped.

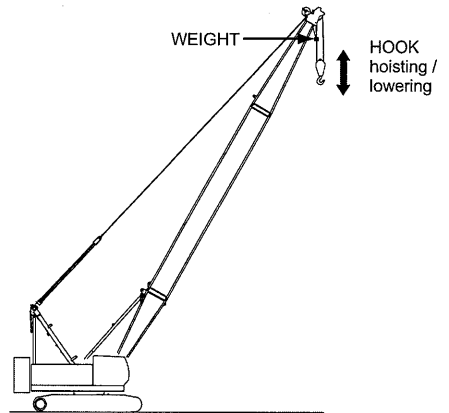

- (2) When the boom is raised to approx. 82 degrees of boom angle, the boom raising must be auto-stopped.

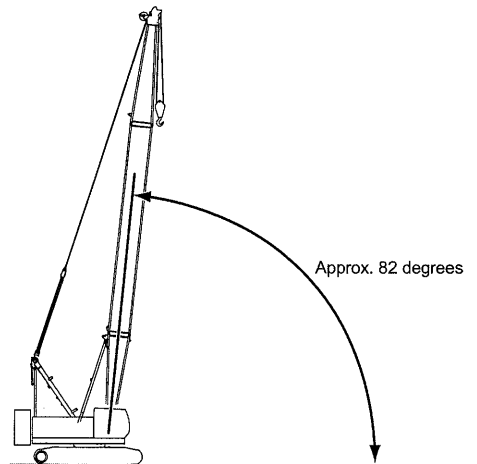

- (3) If it is difficult to test auto-stop function due to overload by lifting the actual load, check can be done in the display. Perform this test in "WORK" position. The test will not work in assembly/disassembly mode.

Press **MENU** icon to indicate menu and then **CRANE** press.

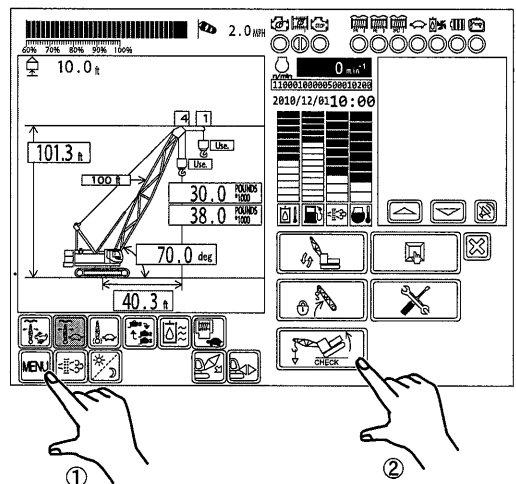

Press  icon.

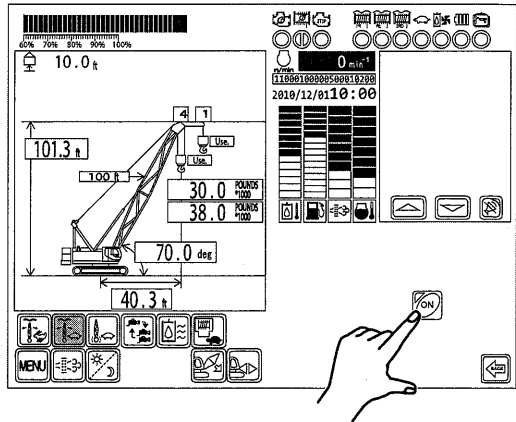

The crane turns to the simulated overload condition and auto-stop occurs.
(Overload check mode)

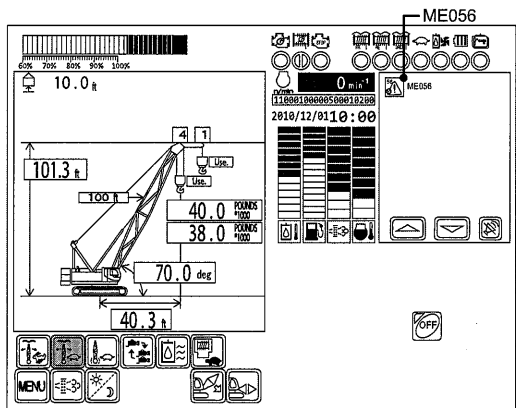

Check to see that hook raising or boom lowering can not be done.
During check mode, message [ME056] appears in the message area.
After the check, press  icon to cancel the check mode is completed.

5.3 LOWERING THE ATTACHMENT

When lowering the attachment, observe the following items.

1. Lowering of the attachment must be performed in the front and rear direction of the crawlers.
2. When the boom angle is less than approx. 30 degrees, place the hook on the ground.
3. Operation must be performed at a low speed. Sudden movement must be avoided.
4. Prevent the wire rope from catching and kink in the tip end of the boom and jib.
5. Place the steel plate under the front end of the crawler when the crane boom length is 70.1 m (230 ft.).
6. Place the steel plate under the front end of the crawler when the jib attached to the 61.0 m (200 ft.) boom length.

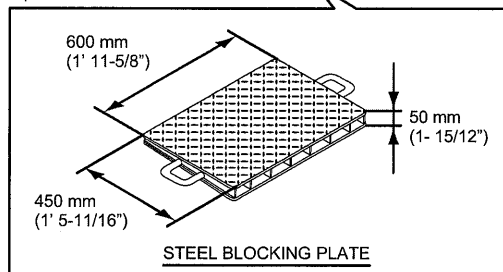
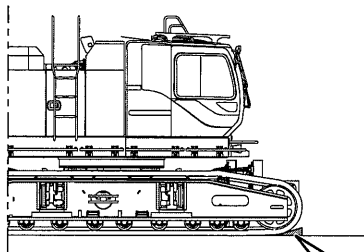

5

⚠ DANGER

Before operating the boom ensure the area above and beneath the boom is clear of all obstructions and personnel.

Failure to observe this precaution may result in a serious injury or loss of life.

5.3.1 LOWERING THE ATTACHMENT

1. Lower the boom at a low speed.
2. When the boom angle exceeds the working area, boom lowering is automatically stopped, and the warning alarm sounds.
3. Lower the hook onto the ground.
4. Return the control lever to neutral then press  (boom/jib lowering icon) on the screen for 1 second.
The automatic stop will be released.
Lower the boom further.
5. The crane enters to the boom lowering mode and the auto-stop due to low boom angle is released to continue lowering the boom. However, when the weight of hook overhoist switch contacts the ground, the auto-stop occurs again due to hook overhoist preventive device.

To lower the boom further, return the control lever to neutral then press  (assy/disassy icon) for 1 second.

Now the crane enters to the assy/disassy mode and the auto-stop due to hook overhoist is released to continue lowering the boom. Operate with care because the hook overhoist automatic stop does not function in the assy/disassy mode.

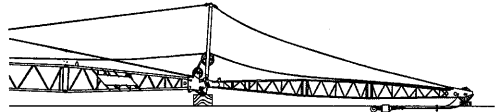
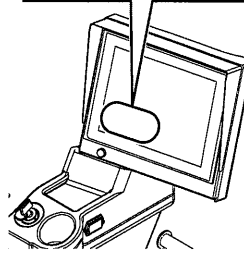
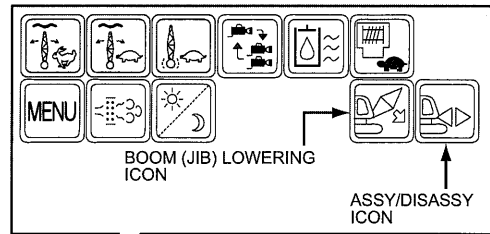

Note

To release auto-stops, press and hold the following button for 1 second.

 (assy/disassy icon) for lowering the boom below 30 degrees.

 (boom/jib lowering) icon for lowering the attachment on the ground.

5.4 DISASSEMBLING THE ATTACHMENT

5.4.1 TREATMENT OF OVERHOIST LIMIT SWITCH WIRING

When disassembling the crane attachment, press  (assy/disassy icon) for 1 second.

Then, the load safety device enters the assy/disassy mode, and the automatic stop functions are disable.

Note

To release auto-stops, press and hold the following button for 1 second.

 (assy/disassy icon) for lowering the boom below 30 degrees.

 (boom/jib lowering icon) for lowering the attachment on the ground.

Note

When the boom angle is high, assy/disassy mode cannot be set.

When the boom is raised after the assembly, assy/disassy mode will be released.

TOOL

- Attached tool set
- Assist crane (25 t capacity)
- Wire rope slings
- Synthetic fiber sling
- Wood blocking
- Corner protectors
- Bar : Φ 20 mm \times 300 mm (Φ 13/16 in. \times 12 in.)
- Ratchet lever hoist (3 t)

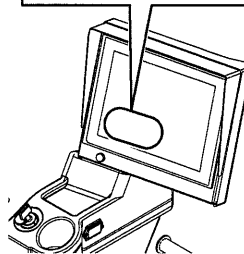
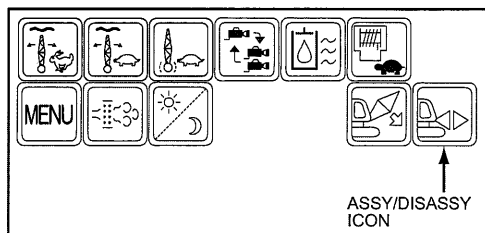

1. Disconnecting the jib wiring

If the jib is installed, disconnect the wiring at jib tip wiring and wind up to the cable reel.
Put the waterproof caps to the disconnected connectors.

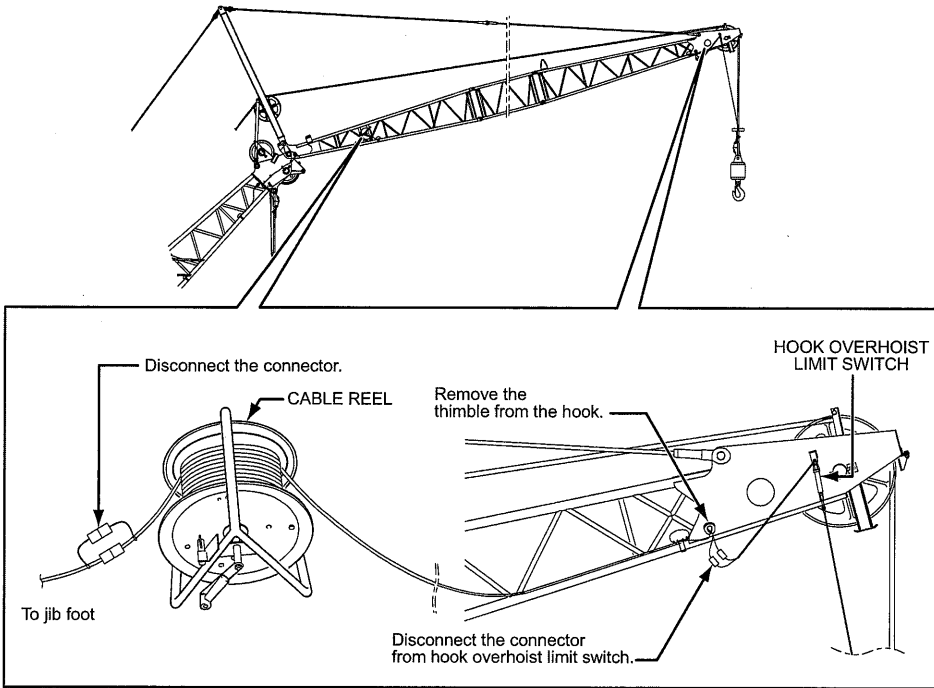

WARNING

When working at an elevated location, watch your step and surroundings.

Utilize fall protection, walkway or aerial platform as needed.

Do not stand on component being connected or disconnected.

Failure to observe these precautions may result in a serious injury or loss of life.

2. Disconnecting the load safety device wiring on the boom tip

Disconnect the hook overhoist limit switch wiring at the boom tip.

Also disconnect the wiring for the auxiliary sheave if used.

Put the waterproof caps on the disconnected connectors.

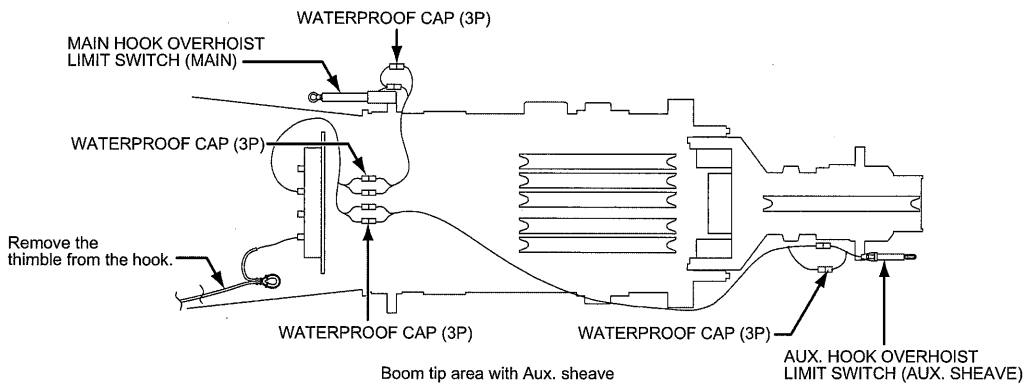
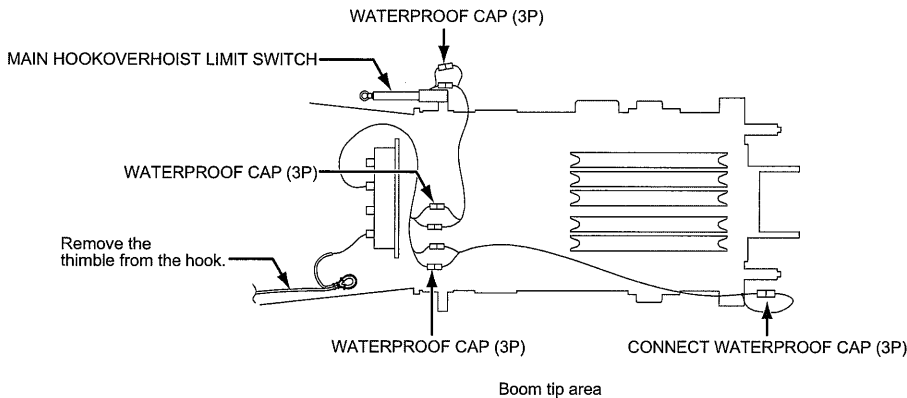

WARNING

When working at an elevated location, watch your step and surroundings.

Utilize fall protection, walkway or aerial platform as needed.

Do not stand on component being connected or disconnected.

Failure to observe these precautions may result in a serious injury or loss of life.

5.4.2 WINDING UP THE FRONT/REAR DRUM WIRE ROPES

CAUTION

Confirm that the hook is placed in the stable condition.

1. Remove the rope socket and clamp from the wire rope end.

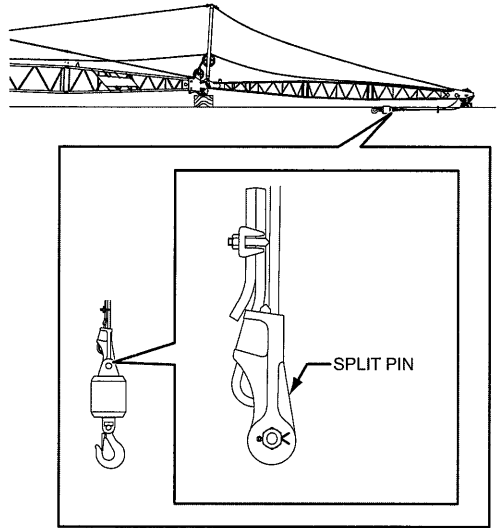

2. Remove the hook overhoist limit switch and weight from the jib point area.

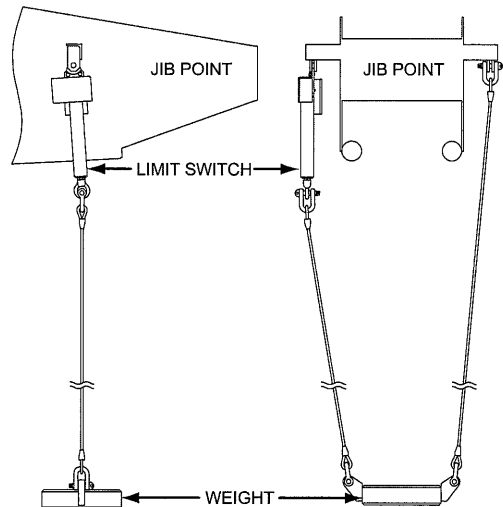

3. Slowly operate the front drum or rear drum control lever to wind up the hoist wire rope onto the corresponding drum, be careful for rope caught on sheave (s).

 **CAUTION**

Do not touch a wire rope directly with bare hands. If wire protrude, you could be injured.

Use protection.

Keep away from rope end when removing the wire rope.

If may suddenly jump and cause injury.

Keep hands and clothing clear of the rotating drum and running rope.

Failure to observe this precaution may result in a serious injury or loss of life.

4. Fix the wire rope end to the drum outer layer with a steel wire after winding up.

5.4.3 DISASSEMBLING THE JIB

1. After lowering the jib on the ground, hold the strut with an assist crane.
Disconnect the boom side jib guy lines from the lugs on the boom insert.
2. Remove the backstop from the strut, and lay it down toward the jib side while holding the strut.

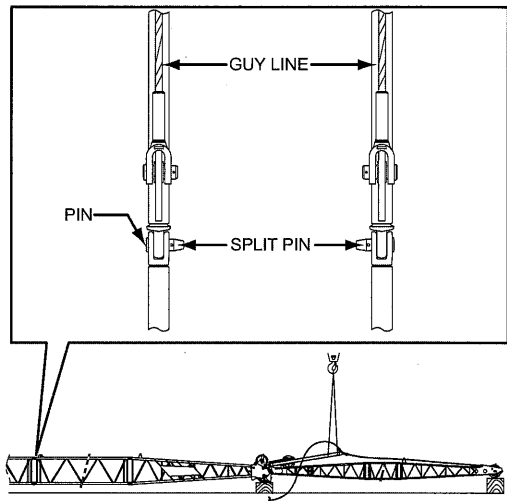
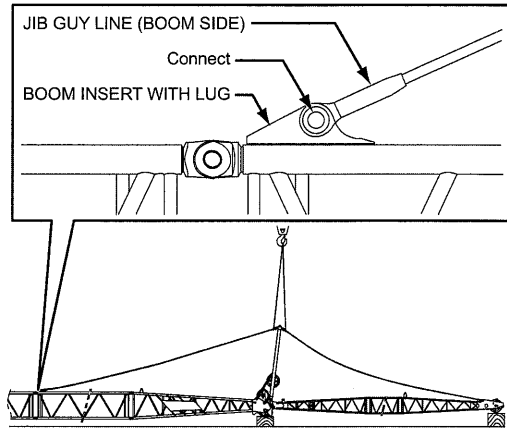

3. Take off the jib guy line from the jib tip end.

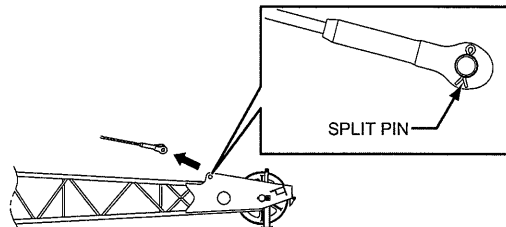

4. Take off the strut equalizer sheaves and jib guy lines.
Re-install the removed equalizer sheaves back to the original positions.

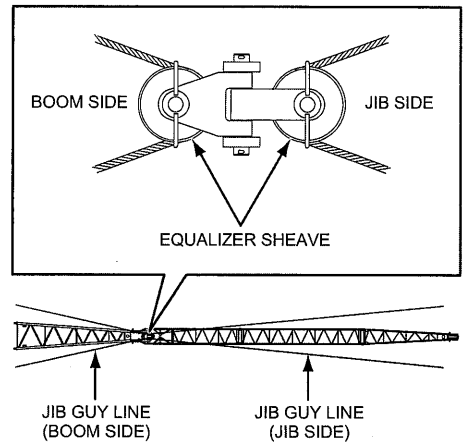

5. With the jib being held with an assist crane, detach the jib from the boom.
Place the jib on wood blockings.

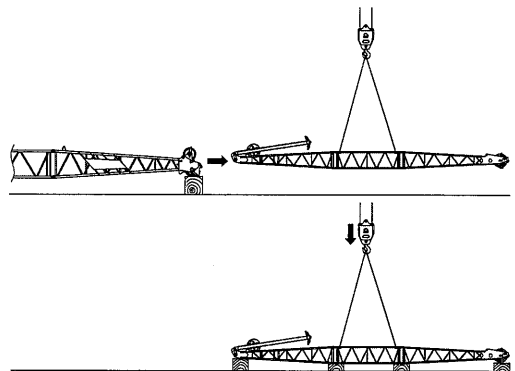

6. First remove the jib tip then jib base, followed by jib insert (s) by disconnecting the pins.
While supporting the component with an assist crane, remove the top pins first and then remove the bottom pins.
When disconnecting the jib connection points, support the jib with the wood blockings to provide stability.

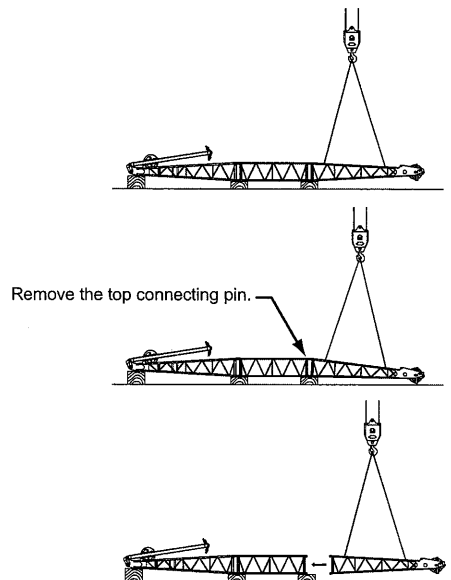

5.4.4 REMOVING THE AUXILIARY SHEAVE

When the Aux. sheave is equipped, remove the Aux. sheave with the following procedure.

Auxiliary sheave weight : 300 kg (660 lbs)

1. Remove the bolt, nut and split pin first and then remove the rope socket from the ball hook.
2. Remove the overhoist limit switch and weight from the Aux. sheave.
3. Wind up the rear drum rope slowly.

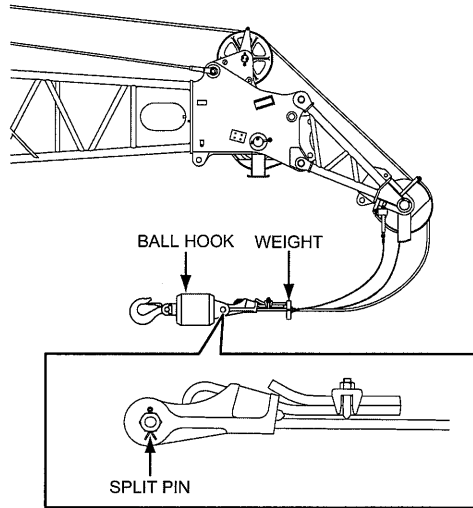

4. Hold the Aux. sheave with the assist crane.
5. Remove the spring pins and the mounting pins as per the procedure as shown right and remove the Aux. sheave.

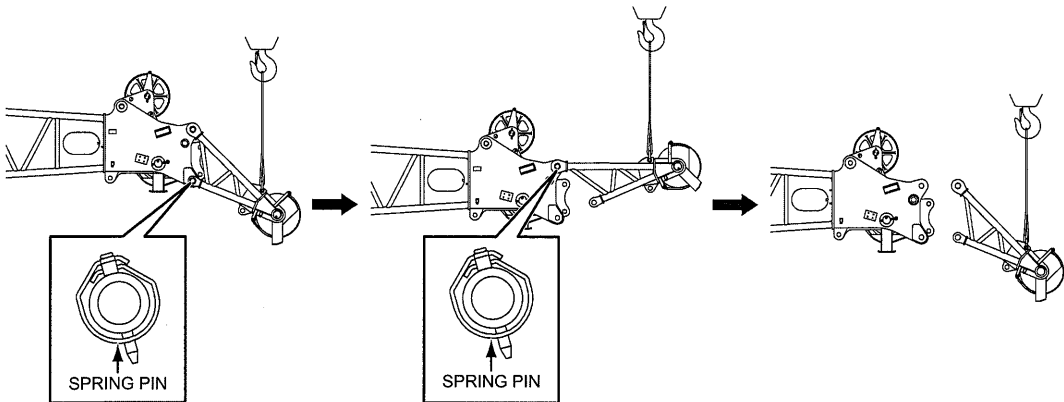

5.4.5 REMOVING THE BOOM GUY LINE

CAUTION

Make sure the booms are fully supported by wood blockings before removing the boom guy line.

1. Set the both spreader guide to the "ASSEMBLY/ DISASSEMBLY" position, and slowly loosen the boom hoist wire rope (Refer to P.5-17).

WARNING

Be sure to support the spreader guide with hands, when removing the pin and handling the guide. Failure to observe this precaution may result in a serious injuries or loss of life.

WARNING

Place a signal person to prevent accident from moving machinery or running ropes. Failure to observe this precaution may result in a serious accident or injury.

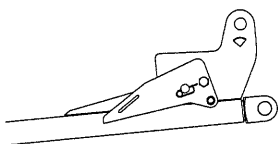

Stowed position

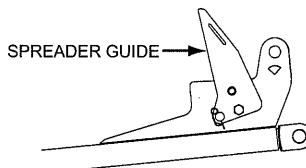

Assembly/disassembly position

2. Use the spreader guide, to install the upper spreader on the boom base with the pin (b).

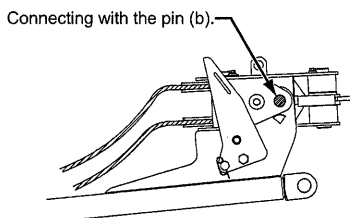
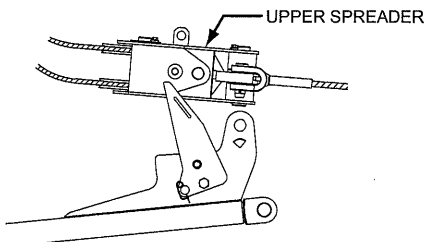

3. Disconnect the guy lines from the upper spreader.

Put back the connecting pins to the upper spreader.

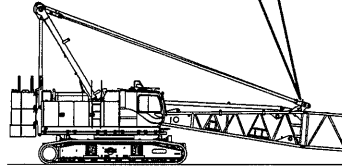
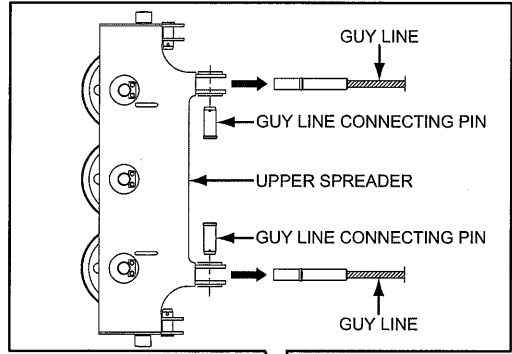

4. Disconnect the connector sections of the guy lines in order.

5. Using an assist crane, lower the guy lines to the ground.
Be careful not to damage the boom.

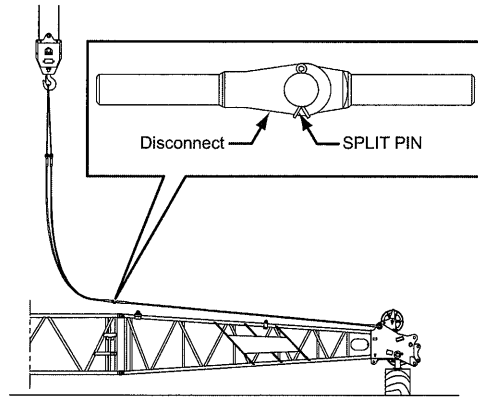

5.4.6 REMOVING THE CABLE ROLLER

Remove the cable roller which is installed on the boom insert.

Remove the cable roller installed on the boom tip if required.

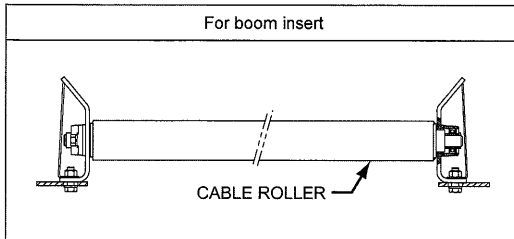

5.4.7 DISASSEMBLING THE BOOM



Do not stand on, or enter under/inside of the boom/jib being connected or disconnected.

Failure to observe these precautions may result in a serious injury or loss of life.

1. Disconnecting the boom tip

While holding the boom tip with an assist crane, draw out the bottom side connecting pins.

Then, draw out the top side connecting pins, to disconnect the boom tip.

Remove the boom tip with using the assist crane.

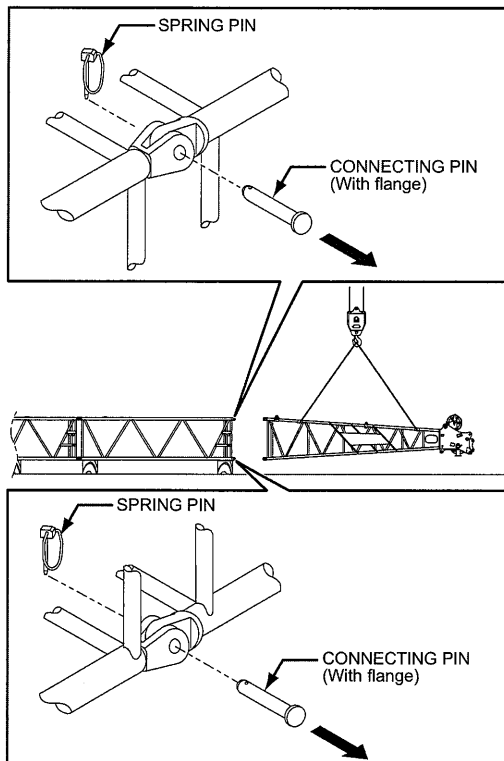

2. Disconnecting the boom base and boom insert

WARNING

Do not stand on, or enter under/inside of the boom/jib being connected or disconnected.

Failure to observe these precautions may result in a serious injury or loss of life.

- (1) Lift up at the connecting point of the boom base and the boom insert, take out the spring pins at the lower connecting pins (double tapered pin) and drive out the pins from outside to inside direction.
Draw out the pin for only one side and insert a bar in the hole to prevent the boom from moving.
- (2) Draw out the pin on the other side of lower connecting pin hole.

WARNING

Do not stand in line with the double tapered pins being inserted/removed.

The pin may fly out from the pinhole.

Failure to observe these precautions may result in a serious injury or loss of life.

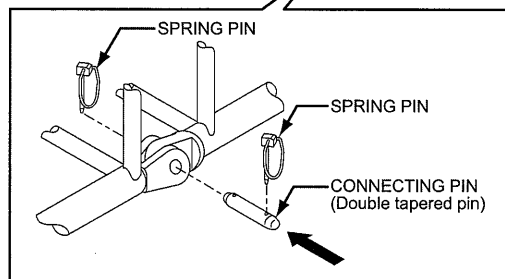
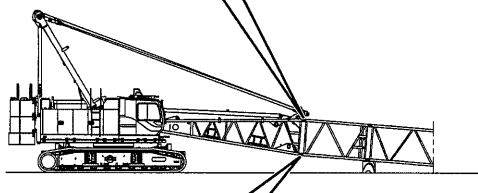
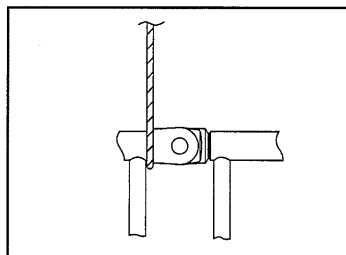

- (3) Remove the bar and slowly lower the boom base which is supported by an assist crane and place it on the wood blockings.
- (4) After confirming that the boom base is stable on the wood blockings, remove the upper connecting pins (with flange) and disconnect it from the boom insert.

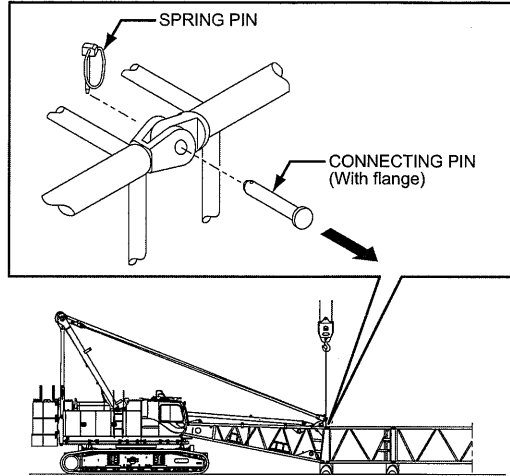

- 3. Disassembling the boom insert
Disconnect the boom insert in order by removing the connecting pins.

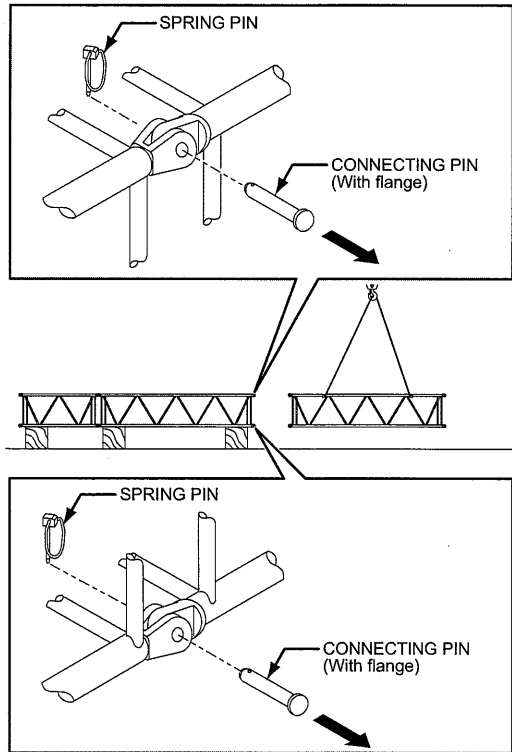

5.5 CAUTION WHEN TRANSPORTING BOOM

1. In order to prevent damaging the boom, do not apply the slings directly to the main chords.
Do not apply slings to the lacings.
Use only synthetic fiber slings.

CAUTION

Do not apply slings to lattice pipes for transport. The lattice pipes may be damaged.

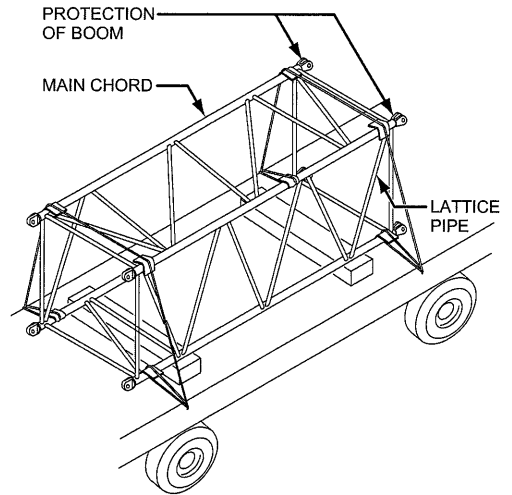

2. Place wood blocking under the both ends of the boom.

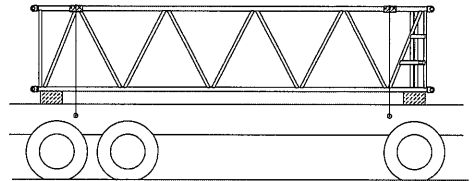

3. When placing a boom on top of another boom, place wood blockings in similar manner to the bottom one.
If one of them has lugs, place it at the bottom to keep the transport height low.

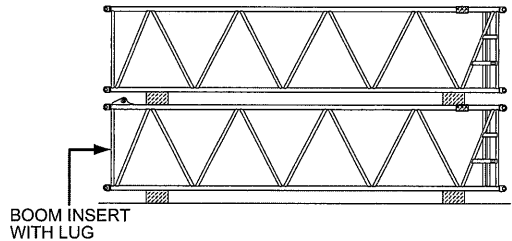

6. WIRE ROPE

6.1	HANDLING OF WIRE ROPE.....	6-1
6.1.1	SPECIFICATION OF WIRE ROPE.....	6-2
6.1.2	WIRE ROPE LENGTH.....	6-6
6.1.3	CAUTIONS IN HANDLING WIRE ROPE.....	6-8
6.1.4	WINDING WIRE ROPE TO THE DRUM.....	6-9
6.1.5	WINDING PROCEDURE OF WIRE ROPE TO DRUM.....	6-10
6.1.6	CORRECTING METHOD OF ENTANGLED WIRE ROPE.....	6-13
6.1.7	ROPE SOCKET INSTALLATION.....	6-16
6.1.8	REPLACEMENT STANDARDS FOR WIRE ROPE.....	6-17

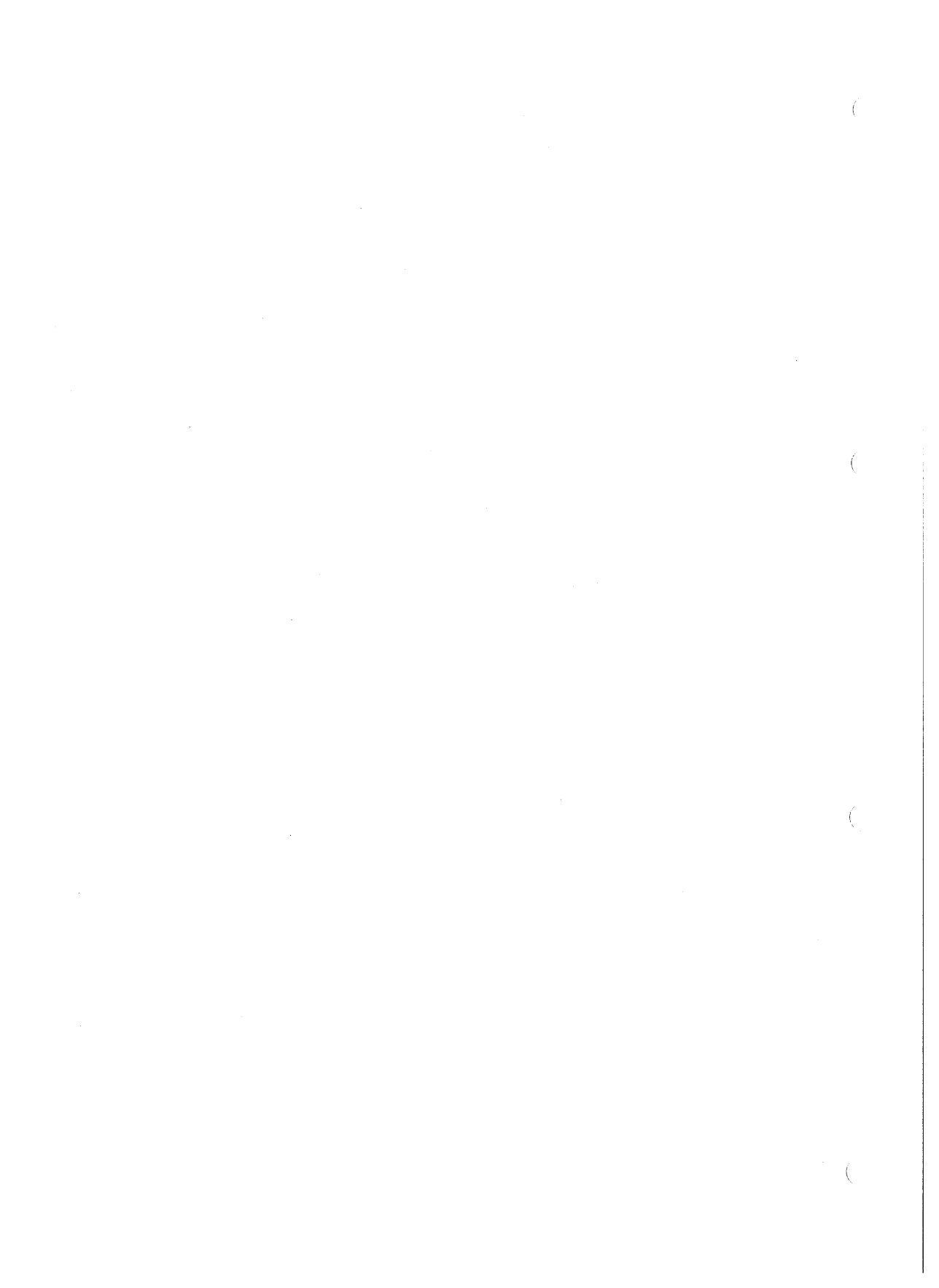

6. WIRE ROPE

6.1 HANDLING OF WIRE ROPE

 CAUTION

When the crane is delivered from factory, maximum length of wire rope required for boom and jib configuration and a number of part lines which is possible has been wound on the drum.

If boom length is short and a number of parts lines are less, rough spooling such as looseness of wire rope, cross winding or biting may occur.

Use of proper rope length based on crane operating conditions (length of boom or jib, number of part lines of rope, lifting height) is recommended.

(Refer to the table in 6.1.2 WIRE ROPE LENGTH.)

The hook has been removed at the factory delivery.

Winding of rope may be loose and rope biting may occur.

If wire rope is loose, rewind the wire rope applying some tension.

 CAUTION

If rope diameter is not correct, biting or rough spooling may occur.

Use genuine wire rope.

 CAUTION

Set the hook and number of parts line of rope properly based on lifting load and length of boom and jib.

 CAUTION

Handle the control lever slowly.

Abrupt returning of the control lever to neutral may cause loose wire rope or rough spooling due to sudden stop of drum.

6.1.1 SPECIFICATION OF WIRE ROPE

Note

Actual lengths of boom section, wire rope are metric.

The values in () are approximate conversion to feet.

1. Wire rope for crane

Use	Rope spec.	Breaking strength kN (lbs)	Rope dia. (mm)	Rope length m (ft)	Part No.
Front drum	IWRC 6 × Fi (29) Right-hand Regular lay	534 (120,048)	26	260 (853)	2408R76D260
Rear drum	IWRC 6 × Fi (29) Right-hand Regular lay	534 (120,048)	26	230 (755)	2408R76D230
Boom hoist drum	IWRC 6 × P-WS (31) Right-hand Regular lay	328 (73,737)	20	155 (509)	2408R307D155
Third drum (Option)	IWRC 6 × Fi (29) Right-hand Regular lay	534 (120,048)	26	190 (623)	2408R76D190

CAUTION

To properly wind the wire rope to the drum, it is recommended to use wire rope with its diameter of 2.5 to 4.5% larger than nominal value.

Wire rope diameter other than this range may cause rough spooling.

2. Wire rope for hydraulic tagline (Option)

Use	Rope spec.	Breaking strength kN (lbs)	Rope dia. (mm)	Rope length m (ft)	Part No.
Hydraulic tagline	FC 6 × W (19) Right-hand Regular lay	58 (13,039)	10	45 (148)	2408R54D45

3. Wire rope for hydraulic tagline (Option)

Use	Rope spec.	Breaking strength kN (lbs)	Rope dia. (mm)	Rope length m (ft)	Part No.
Reeving winch	FC 6 × W (19) Right-hand Regular lay	37 (8,318)	8	260 (853)	2408R123D260

- Ensure to use the specified type of wire rope on each drum at factory shipment by KOBELCO.
- If the diameter of the rope used is out of dimension tolerance range on each drum groove, rope upsetting may be caused.

WINDING CAPACITY OF WIRE ROPE ON EACH DRUM

Front drum, Rear drum, Third drum (option)				
Drum winding capacity on min. Pcd with 26 mm dia. rope.				
Layer	Lane	Min Pcd m (ft)	Winding L on each layer m (ft)	Total winding length m (ft)
1	22	0.614 (2.014)	42.4 (139)	42.4 (139)
2	22	0.658 (2.159)	45.5 (149)	87.9 (288)
3	22	0.702 (2.303)	48.6 (159)	136.5 (448)
4	22	0.747 (2.451)	51.6 (169)	188.1 (617)
5	22	0.791 (2.595)	54.6 (179)	242.7 (796)
6	22	0.835 (2.740)	57.7 (189)	300.4 (985)
7	22	0.879 (2.884)	60.8 (199)	361.2 (1,186)

Min Pcd means theoretical value calculated from the right figure on 2nd or higher layer.

Unit : mm (inch)

Boom hoist drum				
Drum winding capacity on min. Pcd with 20 mm dia. rope.				
Layer	Lane	Min Pcd m (ft)	Winding L on each layer m (ft)	Total winding length m (ft)
1	13	0.480 (1.575)	19.6 (64)	19.6 (64)
2	13	0.514 (1.686)	21.0 (69)	40.6 (133)
3	13	0.548 (1.798)	22.4 (73)	63.0 (207)
4	13	0.582 (1.909)	23.7 (78)	86.7 (284)
5	13	0.616 (2.021)	25.2 (83)	111.9 (367)
6	13	0.650 (2.133)	26.5 (87)	138.4 (454)
7	13	0.684 (2.244)	28.0 (92)	166.4 (546)
8	13	0.718 (2.356)	29.3 (96)	195.7 (642)

Min Pcd means theoretical value calculated from the right figure on 2nd or higher layer.

Unit : mm (inch)

TYPE OF WIRE ROPE

The factory delivered wire ropes do not satisfy all working condition. Selection of proper wire rope to the working condition is required.

The wire rope has its own characteristics. Select the proper wire rope to the working condition referring to the table below.

MAIN WORK CONTENT AND ITS RECOMMENDED HOIST WIRE ROPE TYPE

Work content	Type of wire rope	Remarks
High lifting work <ul style="list-style-type: none"> • Crane, Tower • Jib, Aux. sheave • Rope number of parts line 1 to 2 	U4 × SeS (39)	Even non rotating type, it has rotating property.
General crane work <ul style="list-style-type: none"> • Work with boom shorter than half of maximum boom. Work cycle is comparatively low. • Assisting crane work to foundation work • Clamshell work 	IWRC 6 × Fi (29)	
Large load, High cycle work <ul style="list-style-type: none"> • Block lifting / transposition work • Port loading / unloading work (Grab bucket work) 	IWRC 6 × Fi (29)	
Large load, High cycle work <ul style="list-style-type: none"> • Under ground excavating work (Hammer grab work) 	IWRC 6 × Fi (29) non rotating rope U3 X SeS (48)	Even non rotating type, it has rotating property.
Large load, High cycle work <ul style="list-style-type: none"> • Underground diaphragm wall work (Diaphragm wall bucket work) 	IWRC 6 × Fi (29) non rotating rope U3 X SeS (48)	Even non rotating type, it has rotating property.
Light load, high cycle work <ul style="list-style-type: none"> • Lifting magnet work 	IWRC 6 × Fi (29)	

TYPE OF WIRE ROPE FOR BOOM AND JIB HOIST

Work content	Type of wire rope	Remarks
All construction and foundation work <ul style="list-style-type: none"> • Crane boom hoist • Tower hoist • Tower jib hoist 	IWRC 6 × P-WS (31)	Non shape deformed property, fatigue resistance type rope

6.1.2 WIRE ROPE LENGTH

1. MAIN

Unit : m (ft)

Boom length (m)	Parts of line									
	1 part	2 part	3 part	4 part	5 part	6 part	7 part	8 part	9 part	10 part
15.2 (50)	40 (131)	58 (190)	76 (249)	95 (312)	113 (371)	131 (430)	149 (489)	167 (548)	185 (607)	203 (666)
18.3 (60)	46 (151)	67 (220)	89 (292)	110 (361)	131 (430)	152 (499)	173 (568)	194 (636)	215 (705)	
21.3 (70)	52 (171)	77 (253)	101 (331)	125 (410)	149 (489)	173 (568)	197 (646)	221 (725)		
24.4 (80)	58 (190)	86 (282)	113 (371)	140 (459)	167 (548)	194 (636)	221 (725)			
27.4 (90)	65 (213)	95 (312)	125 (410)	155 (509)	185 (607)	215 (705)				
30.5 (100)	71 (233)	104 (341)	137 (449)	170 (558)	203 (666)	237 (778)				
33.5 (110)	77 (253)	113 (371)	149 (489)	185 (607)	222 (728)	258 (846)				
36.6 (120)	83 (272)	122 (400)	161 (528)	200 (656)	240 (787)					
39.6 (130)	89 (292)	131 (430)	173 (568)	216 (709)						
42.7 (140)	95 (312)	140 (459)	185 (607)	231 (758)						
45.7 (150)	101 (331)	149 (489)	197 (646)	246 (807)						
48.8 (160)	107 (351)	158 (518)	210 (689)							
51.8 (170)	113 (371)	167 (548)	222 (728)							
57.9 (180)	119 (390)	176 (577)	234 (768)							
57.9 (190)	125 (410)	186 (610)	246 (807)							
61.0 (200)	131 (430)	195 (640)								
64.0 (210)	137 (449)	204 (669)								
67.1 (220)	143 (469)	213 (699)								
70.1 (230)	149 (489)	222 (728)								

2. JIB

Unit: m (ft)

Boom length (m)	Jib length (m)				
	9.1 (30)	12.2 (40)	15.2 (50)	18.3 (60)	21.3 (70)
27.4 (90)	81 (267)	87 (287)	93 (306)	99 (326)	105 (345)
30.5 (100)	87 (287)	93 (306)	99 (326)	105 (345)	111 (365)
33.5 (110)	94 (307)	99 (326)	105 (346)	111 (365)	117 (385)
36.6 (120)	100 (327)	106 (346)	111 (366)	117 (385)	123 (405)
39.6 (130)	106 (347)	112 (366)	118 (386)	123 (405)	129 (425)
42.7 (140)	112 (367)	118 (386)	124 (406)	130 (425)	136 (445)
45.7 (150)	118 (386)	124 (406)	130 (425)	136 (445)	142 (464)
48.8 (160)	124 (406)	130 (426)	136 (445)	142 (465)	148 (484)
51.8 (170)	130 (426)	136 (446)	142 (465)	148 (485)	154 (504)
54.9 (180)	136 (446)	142 (466)	148 (485)	154 (505)	160 (524)
57.9 (190)	142 (466)	148 (486)	154 (505)	160 (525)	166 (544)
61.0 (200)	148 (486)	154 (505)	160 (525)	166 (544)	172 (564)

Note

This table indicates the required rope length in case that the hook height is about boom foot.

Note

If the longer rope is used, rope rough spooling on the drum may likely occur.

6.1.3 CAUTIONS IN HANDLING WIRE ROPE

1. Cautions in unloading or during transportation

- Do not drop from the load deck.
- When rolling the wooden rope reel with lever etc, do not touch the wire rope direct with the lever but touch the outer flange area.
- In case of coiled wire rope, do not place or roll over directly on the sandy ground or on the steel pieces.

2. Cautions in storing

- Store the wire rope in dry atmosphere.
In case of outdoor storage, ensure to put the cover to protect from rain.
- Do not place the wire rope directly on the ground but place them approx. 200 to 300 mm (8" to 12") above the ground with wooden blocks.

3. Unreeving the wire rope

When unreeving the wire rope, take extra care not to allow kinking.

It would be convenient to use the jig as shown right.

If such jig is not available, unreeve the wire rope by rolling the reel on the ground taking care not to allow sand or iron pieces adhered.

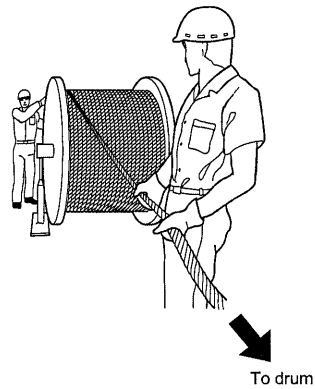

Kink : Deformation by twisting of wire rope

(1)		Loop by twisting wire rope
(2)		Pulled up condition under tension
(3)		Kink occurred
(4)		Wire rope does not return to original shape



Unreeving method of wire rope

6.1.4 WINDING WIRE ROPE TO THE DRUM

- Adjust the wire rope to the proper length suitable to the working condition (boom length, number of rope parts of line and lifting height) to prevent the upper layer of rope penetrating into lower layer when the load is lifted.
- When winding the wire rope to the drum, take care not to cause laying.
- The dead turns of rope on the drum should be wound tight under tension.
- When paying out the rope from the drum, take care not to cause twisting or kink.

Wire ropes are simply wound on the drum and not tight under tension at the factory delivery.

Lifting the large load without tension on the base layer may cause upper layer to penetrate into lower layer and may cause rope deformation, rope upsetting or premature strand cut.

Ensure to feed out all of the wire rope from the drum prior to actual crane work and properly wind the dead turns to the drum applying tension based on the work content.

6.1.5 WINDING PROCEDURE OF WIRE ROPE TO DRUM

1. In case of front and rear drum

Pass the wire rope end through the inside of the drum flange and fix it to the drum flange by pressing with two mounting plates.

Do not allow the rope end to protrude from the drum flange.

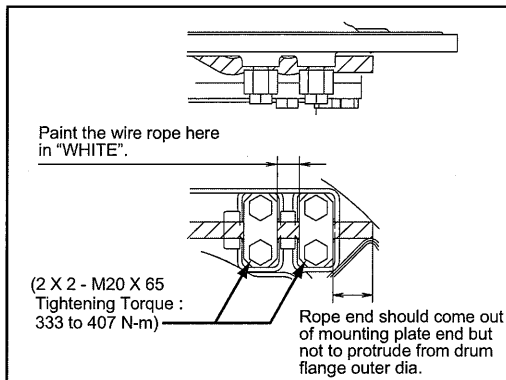

WARNING

If the rope end is not firmly fixed, rope may slip out and the load may drop off.

Ensure to fix the rope end properly.

Failure to observe this precaution may result in serious accident.

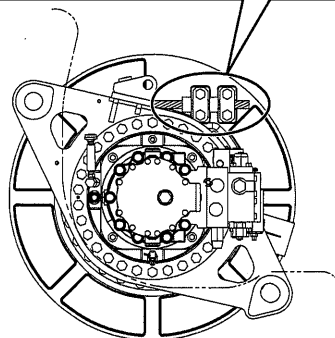

- (1) Pull the wire rope manually and wind up on the drum groove while guiding the rope along the drum end guide.

Make sure that minimum 3 turns remain on the drum even wire rope is paid out to the maximum.

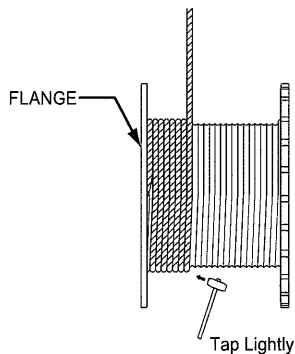

WARNING

If more than 3 turns do not remain on the drum, wire rope may slip out and lifting load may drop.

Ensure to have minimum 3 turns remained on the drum.

Failure to observe this precaution may result in a serious accident.

- (2) Then apply the required tension on the wire rope and wind up to the drum.

Refer to the chapter "Applying tension on the rope" and its figure.

2. In case of boom drum

- (1) Do not allow the wire rope end to come out of drum wedge hole.

Tension side rope should come to the straight face side of socket.

Install the wedge firmly on the drum.

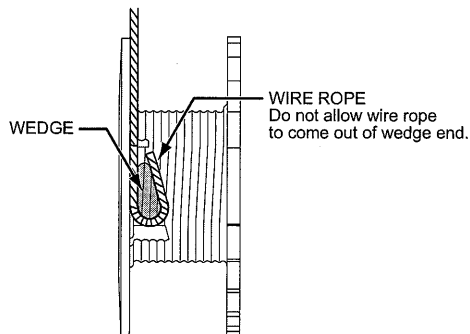

WIRE ROPE INSTALLATION

- (2) Pull the boom hoist wire rope manually and tap lightly on the wire rope to align and wind the wire rope slowly.

Apply tension on the wire rope by boom weight and slowly wind on the drum.

WARNING

Take extra care on running wire rope to prevent accident of being crushed or being entangled.

Failure to observe these precautions may result in serious injuries or loss of life.

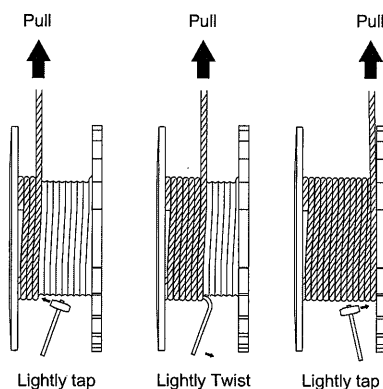

WINDING OF WIRE ROPE
(In case of boom hoist wire rope)

- (3) Make sure that minimum 3 turns remain on the drum even wire rope is paid out to the maximum.

WARNING

If more than 3 turns do not remain on the drum, wire rope may slip out and lifting load may drop off.

Ensure to have minimum 3 turns remained on the drum.

Failure to observe this precaution may result in a serious accident.

- (4) Then apply the required tension on the wire rope and wind the wire rope.

To apply the tension on the wire rope, lift up the whole of boom hoist wire rope between the upper and the lower spreader with an assist crane using a pulley block or apply the boom weight on the boom hoist wire rope between the upper and the lower spreader.

3. Drum flange rope clearance

- (1) If the layer change occurs on the drum flange protruding point (change from 1st layer to 2nd layer), wire rope and drum end area is guided by protruding portion and clearance of about 1/2 of wire rope dia. may be created.

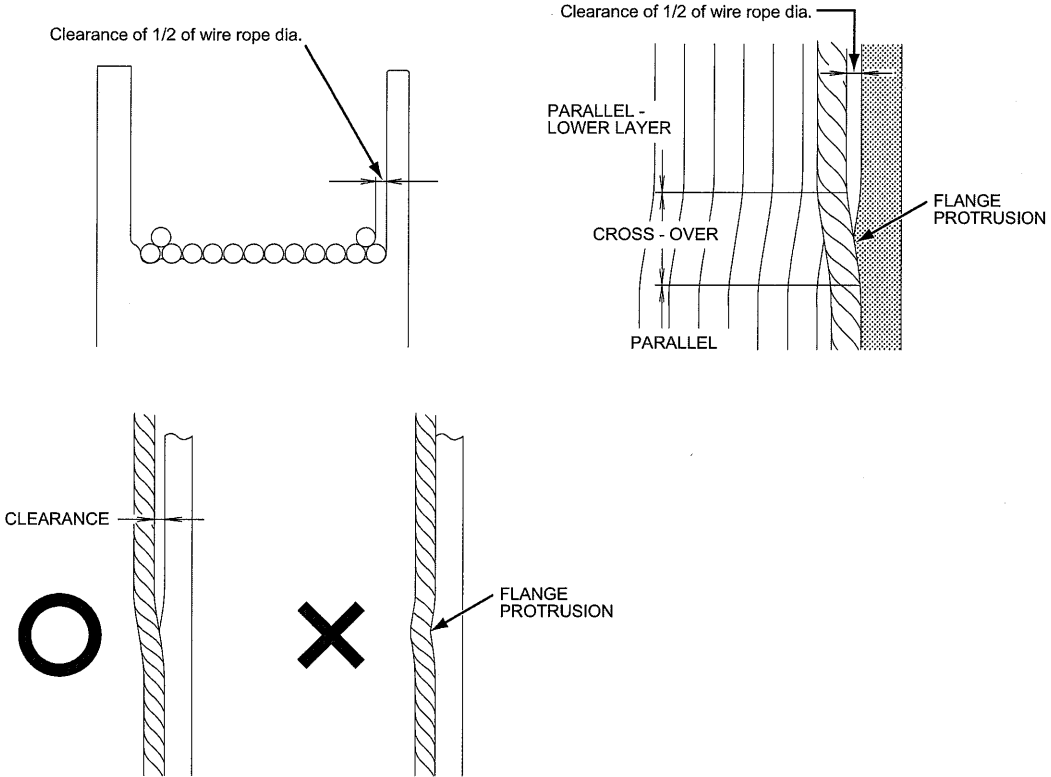

CAUTION

If wound without clearance having wire rope followed the protruding area excessively may cause rope upsetting.

Ensure to provide clearance as shown on the above figure at the protruding area.

- (2) Even if the winding layer becomes multiple layer, wire rope behavior in layer changing area is basically the same as that of between 1st and 2nd layer.

However due to wire rope and drum manufacturing unevenness, layer change area varies as layer becomes larger.

6.1.6 CORRECTING METHOD OF ENTANGLED WIRE ROPE

The wire rope has a tendency to rotate to the direction for returning its lay when the load is applied due to its construction.

This is called "wire rope rotating property".

In case of high lifting crane or lifting with 2 to 3 parts of line on hook rope, wire rope may be entangled or lifting load may rotate due to rope rotating property and work safety or efficiency may be suffered.

When the rope becomes entangled due to this wire rope rotating property, correct them as per the following procedure.

1. Type of wire rope lay

There are two types of wire rope lay, Right hand lay and Left hand lay.
Be careful about the type of lay.

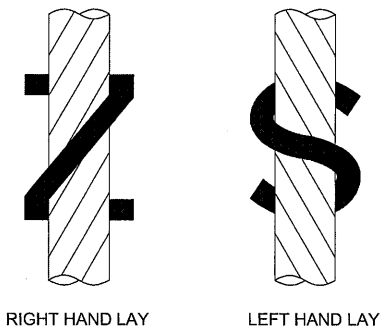

6

2. Correcting method of entangled wire rope

To correct the entangled wire rope, make wire rope end free and loosen the wire rope completely.

Turn the rope socket side end forcibly by repeating hook hoisting or lowering in such way that the applied lay portion will move toward drum side sequentially.

Perform running in of rope by repeating these.

- Method to provide rotating of rope socket area.
Rotate the rope socket in the opposite direction as that of the entangled rope hook.

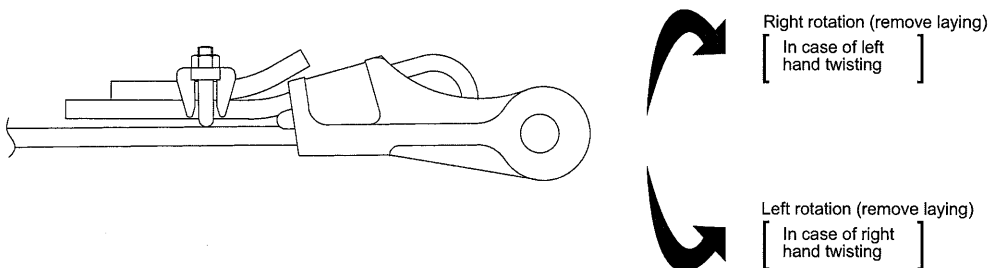

3. Cautions in correcting entangled wire rope

- (1) Number of rotation of rope required for correcting entangled rope.

Number of entanglement x rope number of parts of line = correcting rotation number

Number of entanglement : number of rotation of hook

- (2) Too many rotation in one trial may cause rope shape deformation.

Since it would be difficult to correct evenly throughout the entire length by one trial, limit the rope rotations to 4 to 5 on one trial.

Repeat the correcting for several times based on the conditions.

- (3) The cause of entanglement may vary based on the timing of entanglement occurrence.

Be careful on this point.

If the entanglement occurs just after the rope installation or crane operation, correct them as per the previously mentioned procedure.

If the entanglement occurs sometime after during the crane work, the following causes can be assumed.

If the entanglement occurs sometime after crane work, the following causes can be assumed.

- Wire rope is drawn with the sheave and rope lay move irregularly
- The sheave dia. is too small.
- Wear on sheave groove.
- Fleet angle is too large.
- Contact the nearest KOBELCO for the correction.

 **CAUTION**

Be careful on rope socket rotation due to rope lay when removing the rope socket.

Failure to observe this precaution may result in serious injuries.

- (4) Removing method of rope lay of boom hoist drum wire rope.

In the boom hoist drum wire rope, wire rope may cause waving due to wire rope unlay.

In such case, remove the rope socket and take out the rope lay.

At the same time, inspect the sheave rotation.

6.1.7 ROPE SOCKET INSTALLATION

1. Pass the wire rope through the socket and make loop on the rope end.
Load line of the rope must be in the straight side of the socket.
2. Insert the wedge and pull the wire rope loop with the wedge strongly to secure.
3. secure the wire rope with the rope clamps.
Set the rope clamp to the proper direction.
4. Install the socket to the boom or hook and apply the load to the wire rope to pull in the wedge to the final position.
When installing the rope socket to the boom point, make sure to install in the proper direction.

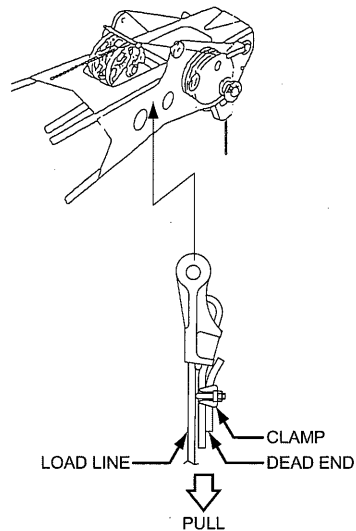
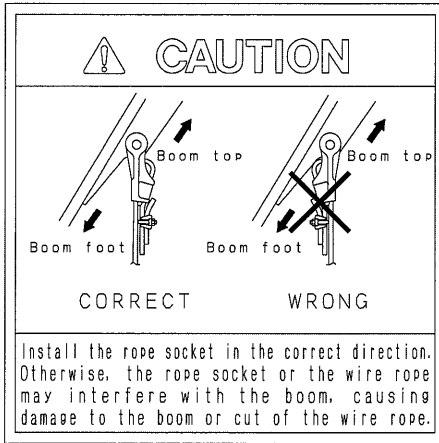
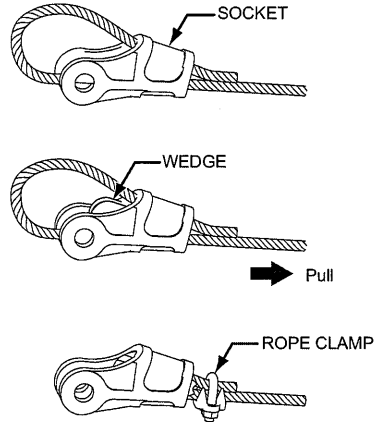

5. When installing the rope socket to the boom, insert the mounting bolt from the boom inner side and secure it with the nut and split pin from outer side.

⚠ DANGER

Insert the rope socket mounting bolt from boom inner side and secure it with the nut and split pin at the outer side.

If secured with nut at the inner side, the wire rope and the split pin would interfere and the nut would become loose and fall off.

Failure to observe this precaution may result in a serious accident.

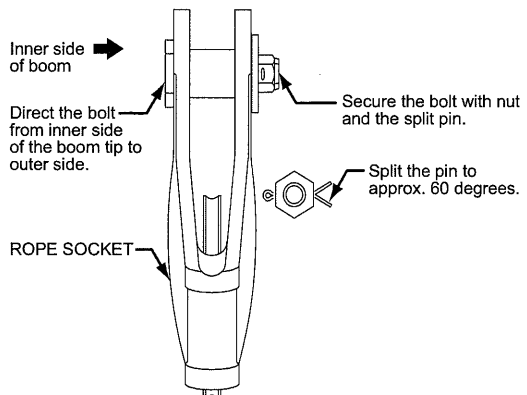

6.1.8 REPLACEMENT STANDARDS FOR WIRE ROPE

1. Check and replacement standards of wire rope

If the wire rope is broken during operation, it might cause a serious accident.

Therefore, check the rope periodically.

Never use those wire ropes that to wire-cut, abrasion, corrosion and other defects are observed.

Such wire rope as given in Items (1) to (5) below must be immediately replaced with a new rope.

And wire rope subject to damage mentioned in Items (6) onwards should be replaced with new one immediately according to the degree of damage.

TYPE OF WIRE ROPE
<ul style="list-style-type: none"> • HOOK HOIST WIRE ROPE • BOOM HOIST WIRE ROPE • THIRD DRUM WIRE ROPE (OPTION) • GUY LINE • TAGLINE WIRE ROPE (OPTION) • REEVING WINCH WIRE ROPE (OPTION)

- (1) 10% or more steel wires are broken excepting filler wires in one lay of wires. Inspection of internal breakage of wires is difficult. To check breakage of wires in the valley section of wire ropes, bend the rope sharply. Broken element wires, if any, will be exposed.

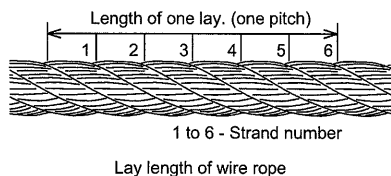

If breakage of wires in the valley section is found, it is considered that internal breakage of wires may also have been developed, and that in other words, fatigue of the whole rope may have been developed.



Bend rope sharply to expose breakage.

- (2) Wire rope of more than 7% (or 5%, under OSHA 1926.1413) reduction in diameter from the nominal diameter, caused by abrasion.

Method of measuring rope diameter.

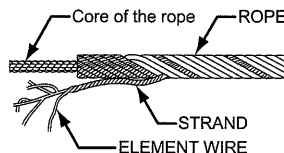
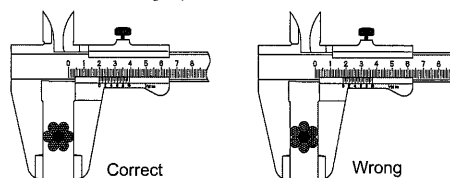

BREAKING LOAD AND DIAMETER

(A) Breaking load

Strength of wire rope is indicated by breaking load.

Breaking load is decided on the strength of wire and tensile strength of each class is specified.

 **CAUTION**

Even on the same diameter rope, different class rope has different breaking load.

Be careful on this point.

(B) Diameter

Diameter of wire rope will be reduced by wear.

Diameter also is reduced by applying overload.

Therefore, it is necessary to keep measuring its diameter for safety.

Do not use the wire rope of which diameter is reduced by 7% from its normal value.

For example, nominal 22 mm diameter rope

$$22 - (22 \times 0.07) = 20.46$$

Therefore if the diameter becomes 20.5 mm it can not be used.

 **CAUTION**

To properly wind the wire rope to the drum, it is recommended to use wire rope with its diameter of 2.5 to 4.5% larger than nominal value.

MEASURING METHOD OF WIRE ROPE DIAMETER

The table below shows how to measure rope diameter

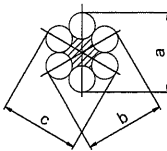
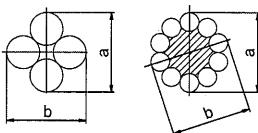
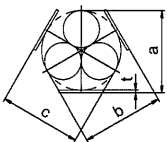
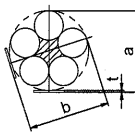
Outer strand number		Diameter measurement	
Even number strand	6 strand	In the same cross section, take measurement at 3 directions and take average value. $d = \frac{a + b + c}{3}$	
	Others	In the same cross sections, measure on almost 90 degree angle and take average of too. $d = \frac{a + b}{2}$	
Odd number strand	3 strand	In the same cross section, place the plate with 1/2 to 1 layer length and its known thickness t at 3 position and take measurement as shown and deduct t from its average value. $d = \frac{a + b + c}{3} - t$	
	Others	In the same cross section, place the plate with 1/2 to 1 layer length and its known thickness t at 3 position and take measurement as shown and deduct t from its average value. $d = \frac{a + b}{2} - t$	

6

HANDLING WIRE ROPE

Wire rope supports large load and its role is important.

If broken, it will cause a serious accident.

Therefore take extra care in handling wire rope.

Degree of wire rope wear or damage varies remarkably depending on handling method.

Take utmost care in safety matters.



Do not bend sharply directly on the sharp corner.

This will affect the strength of the wire rope.

Put the protective covering on the sharp corner.

Failure to observe this precaution may result in serious injuries.

(3) Kink is observed in the wire rope.

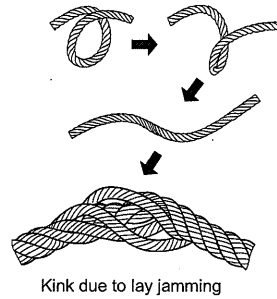

- (4) Due to upper layer wire rope with load penetrated into lower layer wire rope and lower wire rope is excessively deformed.
- (5) Excessive deformation or corrosion is observed on the wire rope.
- (6) Excessive elongation is observed due to overloading or derailment from sheaves.
- (7) A short circuit has been formed electrically.
- (8) Those wire ropes that are subject to fire or spark by electric current or by gas welding as well as subject to high temperature.

1. Replacement standard for guy line

Since damage and corrosion are caused by fatigue from the inside in the boom guy line, replacement time cannot be judged from the appearance.

If the guy line is broken by progressing of internal damage and/or corrosion, there is possibility to cause a serious accident.

Be sure to replace the guy line periodically.

Replacement time according to the content of work is shown in the table.

Contents of Work	Recommended Interval
Normal crane work	6 years
Both crane and clamshell work, or frequent crane work such as landing work	4 years
Lifting magnet or clamshell work only	2 years

2. Overhoist limit switch weight rope

Replace the wire rope as soon as possible if its vinyl tubing is broken or it is subject to the above mentioned replacement standard.

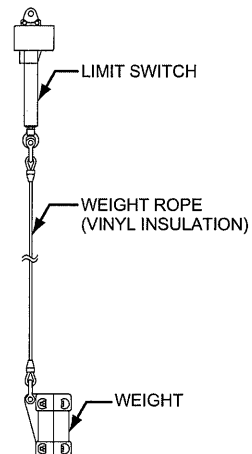

7. MAINTENANCE

7.1	INSPECTION INTERVAL.....	7-9
7.1.1	INSPECTION POINT	7-9
7.1.2	GREASING (WATER SUPPLY) POINT.....	7-12
7.2	INSPECTION.....	7-15
7.2.1	INSPECTION OF UPPER MACHINERY	7-15
7.2.2	INSPECTION OF LOWER MACHINERY	7-22
7.2.3	INSPECTION OF ATTACHMENT.....	7-24
7.2.4	INSPECTION METHOD OF EACH POINT.....	7-26
7.3	OIL/GREASE SUPPLY AND WATER SUPPLY.....	7-50
7.3.1	UPPER LUBRICATION (INCL. WATER SUPPLY).....	7-54
7.3.2	LOWER LUBRICATION	7-58
7.3.3	ATTACHMENT LUBRICATION	7-60
7.3.4	INSPECTION, GREASING (WATER SUPPLY) ON EACH POINT.....	7-62
7.4	CLEANING/WASHING/CHANGING FILTER ELEMENT AND STRAINER	7-82
7.5	BATTERY INSPECTION.....	7-101
7.6	LOCATION AND USE OF FUSE	7-106
7.7	OPERATION UNDER SEVERE CONDITIONS	7-108
7.8	HANDLING OF DIESEL PARTICULATE FILTER.....	7-112
7.9	MACHINE STORAGE.....	7-115
7.10	TIGHTENING TORQUE VALUES.....	7-116
7.11	PERIODICAL REPLACING SECURITY PARTS.....	7-120
7.12	ADJUSTMENT.....	7-123
7.12.1	ADJUSTMENT OF FRONT, REAR, THIRD DRUM LOCKS	7-123
7.12.2	ADJUSTMENT OF BOOM DRUM LOCK.....	7-124
7.12.3	CRAWLER SHOES ADJUSTMENT	7-126
7.13	CONSUMABLE PARTS LIST	7-127
7.14	MEASURES REQUIRED FOR FRONT, REAR WINCH MONITORING.....	7-133
7.14.1	THEORETICAL SERVICE LIFE.....	7-133
7.14.2	USED PROPORTION OF THEORETICAL SERVICE LIFE	7-134
7.14.3	EXAMPLE.....	7-139



7. MAINTENANCE

In order to use this machine always safely in the best condition, preventive maintenance is required.



When checking the machine, lower the boom down to the ground, stop the engine and engage all locks.

Also remove the keys or battery cables to prevent other personnel from starting the crane while maintenance personnel are at work.

Failure to observe this precaution may result in a serious injury or loss of life.

1. Precautions when performing check and maintenance
 - Carry out check and maintenance with a suitable working clothes on.
 - Be sure to set the machine on a firm and level ground, and post a notice board showing "Under Check and Inspection".
 - Check and maintenance in an elevated place, be sure to use a scaffold and safety harness.
Be sure to use a working scaffold and safety belt.
 - When moving to perform check and maintenance, determine the fixed signals, and move the machine following the signals.
 - When performing check and maintenance of hydraulic equipment, be careful to prevent dust and dirt from entering.

2. Inspection table

- The following check table is based on the average operating condition.
Consider the check schedule according to the working condition and weather condition.
- The check table covers all items, but if operators and maintenance personnel judge that additional items are necessary, add them to the check items.
- Whenever a question arises regarding check and maintenance, consult the local representative.



When necessary repairs or adjustments are noted during an inspection, be sure to complete the repairs or adjustments immediately.

3. Maintenance

- Maintenance
When replacement of parts and readjustment are required by check, immediately replace or adjust.
If repair is necessary, consult the service shop designated by KOBELCO.
- Parts
Use the KOBELCO genuine parts for replacement parts and lubricant to be used in order to keep performance of the machine.
The consumable items such as elements, etc. must be replaced somewhat early in order to prevent deterioration.
Any questions, regarding check and maintenance, consult the service shop designated by KOBELCO.

4. Precautions when performing inspections and maintenance
 - Be sure to use KOBELCO genuine parts for replacement parts and KOBELCO specified lubricant to be used.

CAUTION

The warranty does not cover malfunctions caused by the use of parts other than KOBELCO genuine parts (genuine oil, grease and filter).



- Do not use fuel other than specified one.

WARNING

Use ultra low sulfur diesel fuel only (S50 : sulfur content lower than 50 ppm).

If fuel other than specified one is used, adverse affect may be caused to the engine or diesel particulate filter and white smoke or failure may be resulted.

- Use recommended engine oil.

CAUTION

In order to keep good function of the diesel particulate filter, it is recommended to use the specified brand (recommended) engine oil.

- Use clean oil and grease.
Keep the containers for oil and grease to prevent dust and water from entering.
Be sure to use clean oil and grease.

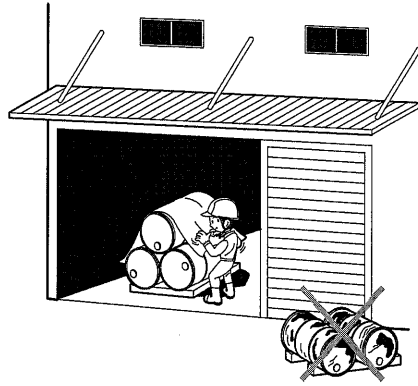

- Clean machine.
Wash the machine to make finding of oil leak, crack, loosening and other wrong condition easy.
Especially, clean grease fittings, breathers and oil level gauge parts (window for check of oil), and avoid entering of dust.

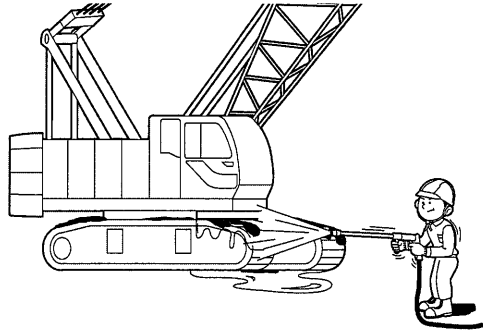

- Disposal of spilled oil.
Leaving oil spilled when refilling or replacing fuel, hydraulic oil, various lubricants, or replacing the filter, may lead to a fire accident.
Thoroughly wipe it.

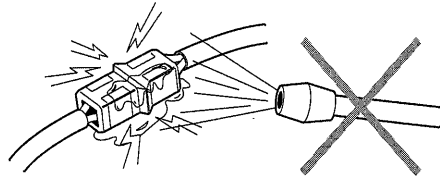

- Caution when washing the machines.
Do not aim pressure wash or steam directly to electric parts and connectors.

- Place a warning plate under checking.
When performing check and maintenance, be sure to indicate warning plate "Do not start under checking." to the key switch.

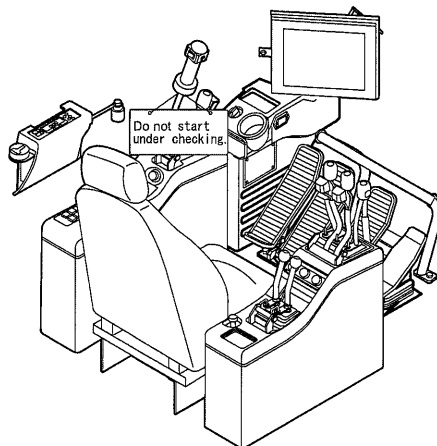

- Keep fire away.
Wastes with oil and combustibles should be stored in a safe place without fire.
Confirm the storage position and using method of fire extinguisher for emergency.



- Pay attention to moving parts!
When checking fan belt tension or water pump, it may become entangled in moving machinery.
Stop the engine, then work.

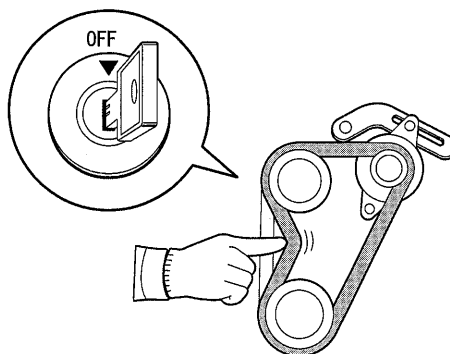

- Pay attention to temperature of water and oil.
Since draining oil, draining water and replacing filter just after the engine stops is dangerous, wait until the temperature lowers, then perform these works.
However, when oil is cold, warm the oil properly (approximately 20°C to 50°C [68°F to 122°F]).

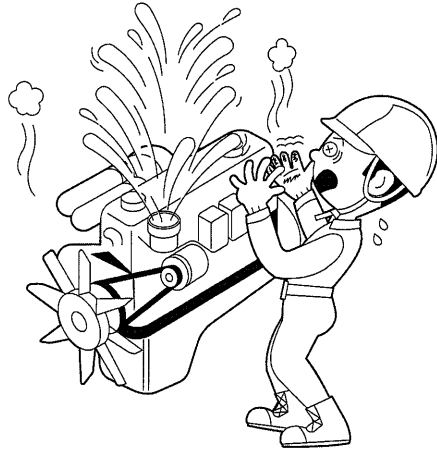

- Check the drained oil and filter.
When replacing oil or filter, check the drained oil and oil filter to see if the significant amount of metal powder or foreign material are included.

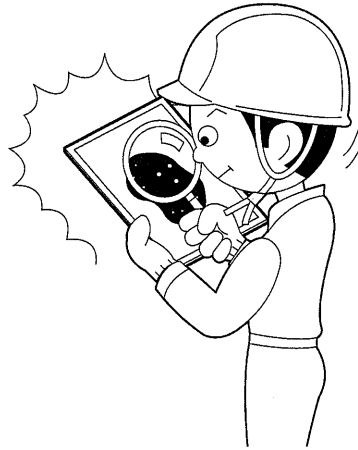

- Pay attention to dust.
Install the clean plug or cap to the oil holes of the disconnected hyd. hoses to prevent contamination of foreign material.

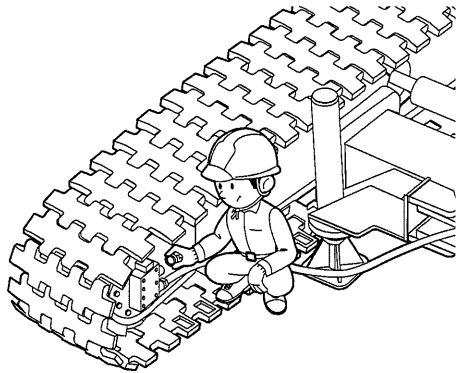

- Clean mounting Surfaces.
When sealing sections of O-rings and gaskets were removed, clean the mounting surfaces, then replace with new ones.
When assembling, apply a thin coat of oil to the seals.

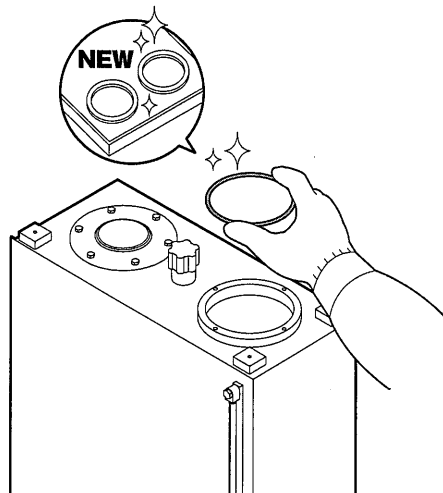

- Pay attention to internal pressure.
When removing hydraulic system, air system, fuel system or pipings and connectors of cooling system and other related parts which have internal pressure, bleed internal pressure beforehand.

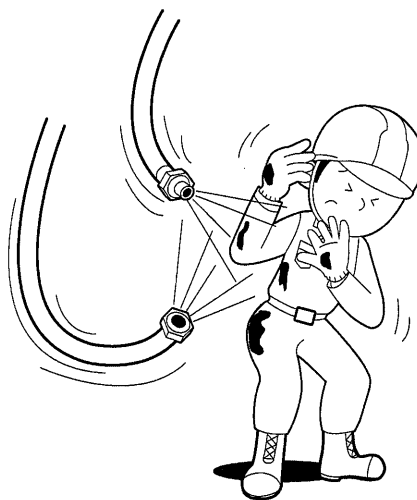

- Precaution when welding.
 1. Turn off power supply (turn the key switch off).
 2. Disconnect the cable of \ominus side of the battery.
 3. Do not apply voltage more than 200 volts continuously.
 4. Provide earth (ground) within 1 meter from the welding section.
 5. There should be no seal and bearing to enter between the welding section and earth point.
 6. When welding near the load safety device and controller, remove them to prevent damage.

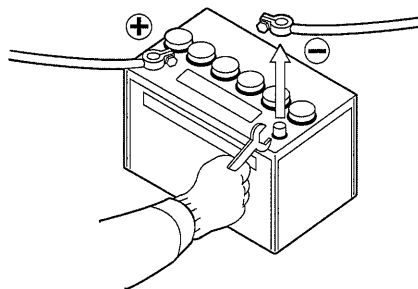

- Treatment of drained oil.
Be sure to drain discarded oil into a container,
and treat it as industrial discharges.



- Caution for adjustment, disassembly.
Never adjust or disassembly the engine,
hydraulic component and the electronic
components (controller etc.).
Failures due to unauthorized modification,
unauthorized parts installation or wrong
handling of components would not be covered
by WARRANTY.

7.1 INSPECTION INTERVAL

7.1.1 INSPECTION POINT

This table summarizes inspection interval of crane on upper machinery, lower machinery and attachment.

Refer to the article "7.2 INSPECTION" for detail of inspection points and inspection method.

Numbers in this table correspond with numbers in P.7-15.

[7. MAINTENANCE]

Item	Inspection point	Check interval (hourmeter : Hr)				
		8 or every shift	50	100	250	500
Upper machinery	1. FUEL AND HYDRAULIC LINES	○				
	2. ENGINE	○				
	3. HOSE, PIPING AND CONNECTOR	○				
	4. SWING BRAKE	○				
	5. SWING LOCK	○				
	6. CONTROL LEVER, BRAKE PEDAL	○				
	7. GANTRY	○				
	8. HORN, WORK LIGHT AND WIPER	○				
	9. AIR CLEANER	○				
	10. PIN, LINK AND COTTER PIN	○				
	11. BOLT AND NUT	○				
	12. HOOK OVERHOIST PREVENTIVE DEVICE	○				
	13. BOOM OVERHOIST PREVENTIVE DEVICE	○				
	14. LOAD SAFETY DEVICE, MONITOR	○				
	15. DRUM LOCK	○				
	16. WINDOW GLASS, STEP, HANDLE AND GUARD	○				
	17. DRUM BRAKE DISK (FRONT AND REAR)	○				
	18. FUEL PRE-FILTER		○			
	19. FAN BELT			○		
	20. RADIATOR AND OIL COOLER			○		
	21. ENGINE MOUNTING BOLT AND RUBBER MOUNT			○		
	22. POWER DIVIDER			○		
	23. HYDRAULIC MOTOR AND REDUCTION UNIT			○		
	24. VALVE, ETC.			○		
	25. HYDRAULIC PUMP			○		
	26. GANTRY CYLINDERS			○		
	27. DRUM LOCK			○		
	28. FUEL SUPPLY PUMP AND HOSE (OPTION)			○		
	29. SWING ALARM			○		
	30. ACCUMULATOR					○
	31. SWING FRAME					○

* The item numbers in the above table correspond to the numbers in the following description.

* The item numbers, 3, 10, 11 are not indicated in the drawing.

Item	Inspection point	Check interval (hourmeter : Hr)				
		8 or every shift	50	100	250	500
Lower machinery	32. HOSE, PIPING AND CONNECTOR	○				
	33. PIN, LINK AND COTTER PIN	○				
	34. BOLT AND NUT	○				
	35. HYDRAULIC MOTOR AND REDUCTION UNIT			○		
	36. VALVE, ETC.			○		
	37. CRAWLER EXTEND/RETRACT CYLINDER, TRANSLIFTER CYLINDER			○		
	38. SWIVEL JOINT			○		
	39. SLEWING BEARING			○		
	40. CRAWLER SHOE			○		
	41. DRIVE TUMBLER, IDLER WHEEL AND UPPER/LOWER ROLLER				○	
	42. SLEWING BEARING MOUNTING BOLT				○	
	43. FRAME					○
	Attachment	44. UPPER SPREADER AND LOWER SPREADER	○			
45. HOOK AND LATCHES		○				
46. CABLE ROLLER AND GUIDE ROLLER		○				
47. SHEAVE		○				
48. BOOM AND JIB		○				
49. PIN, LINK AND COTTER PIN		○				
50. BOLT AND NUT		○				
51. BACKSTOP		○				
52. STRUT		○				
53. WIRE ROPE AND GUY LINE		○				
54. LOAD DETECTOR ROPE SOCKET PIN, BOLT, NUT		○				
55. HOIST WIRE ROPE CLAMP BOLT		○				

7

* The item numbers in the above table correspond to the numbers in the following description.

* The item numbers, 33, 34, 49 and 50 are not indicated in the drawing.

OSHA § 1926.1412 Inspections

Item	Content	Every shift	Every month	Every year
Ground conditions	Soil, water inclusion	○	○	○
Equipment leveling	Horizontalness shall satisfy maker's recommendation	○	○	○
Warning labels and decals	Missing, unreadable condition	—	—	○
Operator seat	Not appropriate for use	—	—	○

7.1.2 GREASING (WATER SUPPLY) POINT

This table summarizes interval of grease supply (water supply) of crane on upper machinery, lower machinery and attachment.

Refer to the article "7.3 OIL/GREASE SUPPLY AND WATER SUPPLY" for detail of grease supply (water supply) points and supply method.

Numbers in this table correspond with numbers in P.7-50.

Item	Inspection point	Check interval (hourmeter : Hr)						
		8 or every shift	50	100	250	500	1000	2000
Upper machinery	1. FUEL TANK *1	○						
	2. ENGINE	○						
	3. RADIATOR	○						
	4. HYD. OIL TANK	○						
	5. DRUM LOCK (FRONT, REAR, THIRD, BOOM)		○					
	6. HYD. OIL TANK		○					
	7. SWING REDUCTION UNIT			○				
	8. POWER DIVIDER			○				
	9. DRUM SHAFT BEARING				○			
	10. REDUCTION UNIT (FRONT, REAR, THIRD DRUM [OPTION])				○			
	11. REDUCTION UNIT (BOOM DRUM)				○			
	12. ENGINE (ENGINE OIL) *2				○			
	13. FUEL TANK					○		
	14. RADIATOR *3						○	
	15. REDUCTION UNIT (SWING)						○	
	16. REDUCTION UNIT (FRONT, REAR, THIRD DRUM [OPTION])						○	
	17. REDUCTION UNIT (BOOM DRUM)						○	
	18. POWER DIVIDER						○	
	19. HYDRAULIC OIL TANK							○
	20. WASHER TANK							○

Item	Inspection point	Check interval (hourmeter : Hr)						
		8 or every shift	50	100	250	500	1000	2000
Lower machinery	21. SLEWING BEARING		○					
	22. REDUCTION UNIT (PROPEL)				○			
	23. SLEWING RING GEAR *4				○			
	24. AXLE EXTENSION				○			
	25. TRANSLIFTER ARM MTG. PIN				○			
	26. REDUCTION UNIT (PROPEL)						○	
	27. LOWER ROLLER *5							
	28. UPPER ROLLER *5							
	29. IDLER WHEEL *5							
Attachment	30. BOOM FOOT PIN	○						
	31. GANTRY LINK	○						
	32. HOOK SHEAVE		○					
	33. HOOK BEARING		○					
	34. BALL HOOK BEARING		○					
	35. FRONT DRUM ROPE GUIDE SHEAVE		○					
	36. BOOM POINT SHEAVE					○ *7	○ *6	
	37. IDLER SHEAVE					○ *7	○ *6	
	38. AUXILIARY SHEAVE					○ *7	○ *6	
	39. UPPER SPREADER SHEAVE (BOOM HOIST)					○ *7	○ *6	
	40. LOWER SPREADER SHEAVE (BOOM HOIST)					○ *7	○ *6	
	41. GANTRY PEAK SHEAVE					○ *7	○ *6	
	42. STRUT SHEAVE						○ *6	
	43. STRUT EQUALIZER SHEAVE						○ *6	
	44. JIB POINT SHEAVE						○ *6	
	45. FRONT, REAR DRUM HOIST WIRE ROPE *8							
	46. BOOM DRUM HOIST WIRE ROPE *8							
	47. BOOM GUY LINE *8							
	48. JIB GUY LINE *8							

7

- *1 Replace item 1 when required.
- *2 Replace item 12 at the initial 50 hours.
- *3 As for item 14, this is when the long life coolant is used.
On the other case, replace item 14 on every 6 months.
- *4 Replace item 23 on every week or every 50 hours operation in case of clamshell or lifting magnet work.
- *5 Replace item 27 to 29 at the overhaul time, unless any abnormality such as oil leak is noted.
- *6 Item 36 to 44 are grease sealed type.
In case of general crane work, grease on every 1,000 hours.
If plug is installed to sheave pin or sheave, change it with grease fitting.
- *7 Item 36 to 41 are grease sealed type.
In case of clamshell, lifting magnet or hammer grab, grease on every 500 hours.
If plug is installed to sheave pin or sheave, change it with grease fitting.
- *8 Apply lubricant on each wire rope as required based on work condition.
When lubricating to wire rope, use brush or spray.

7.2 INSPECTION

7.2.1 INSPECTION OF UPPER MACHINERY

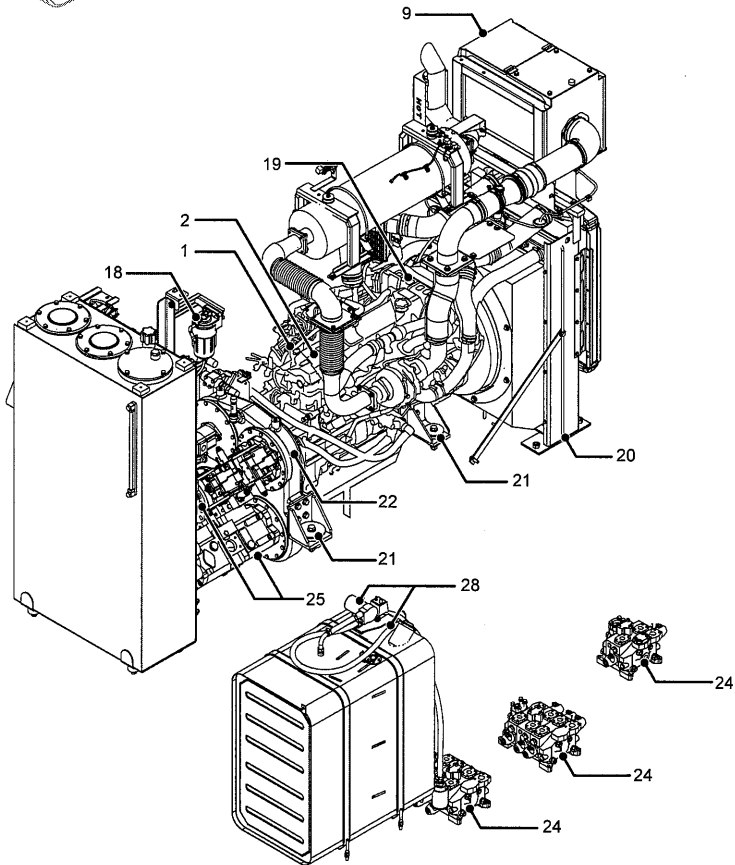
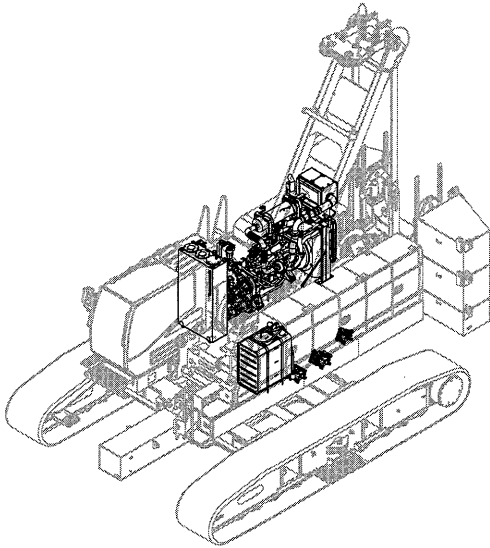

7

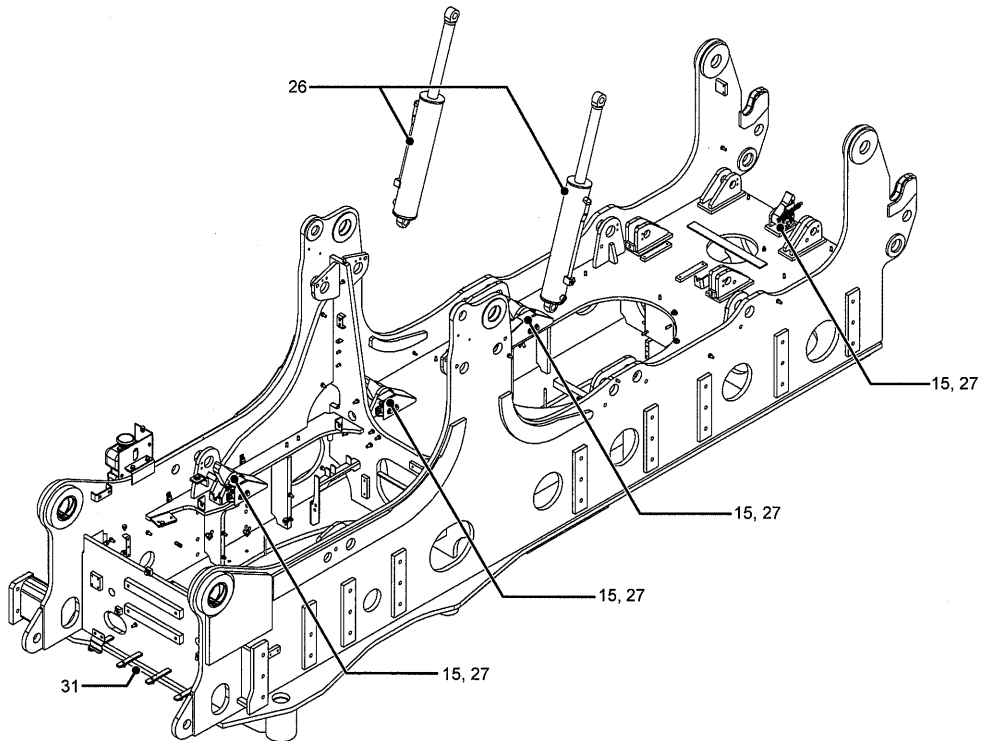
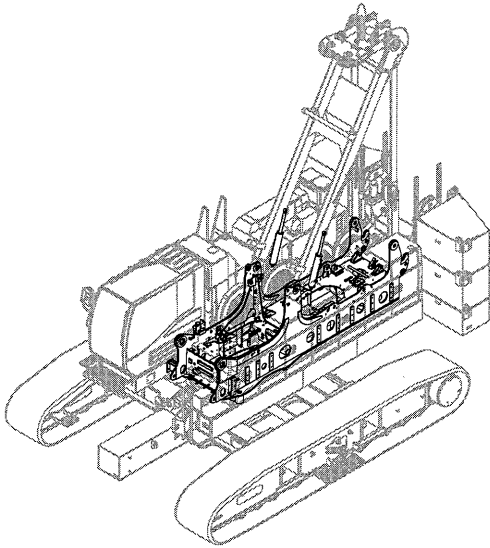

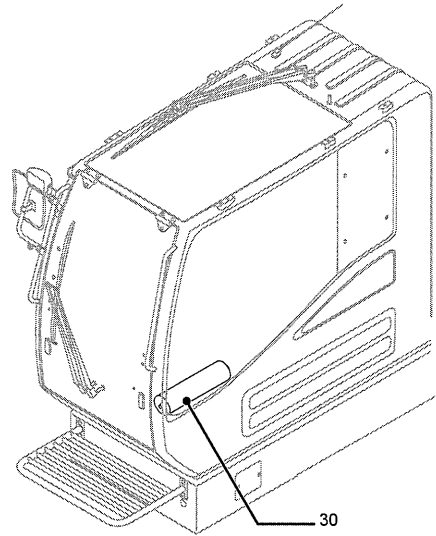
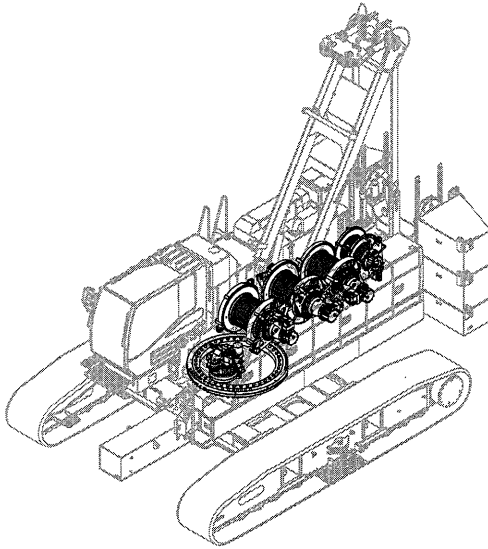

7

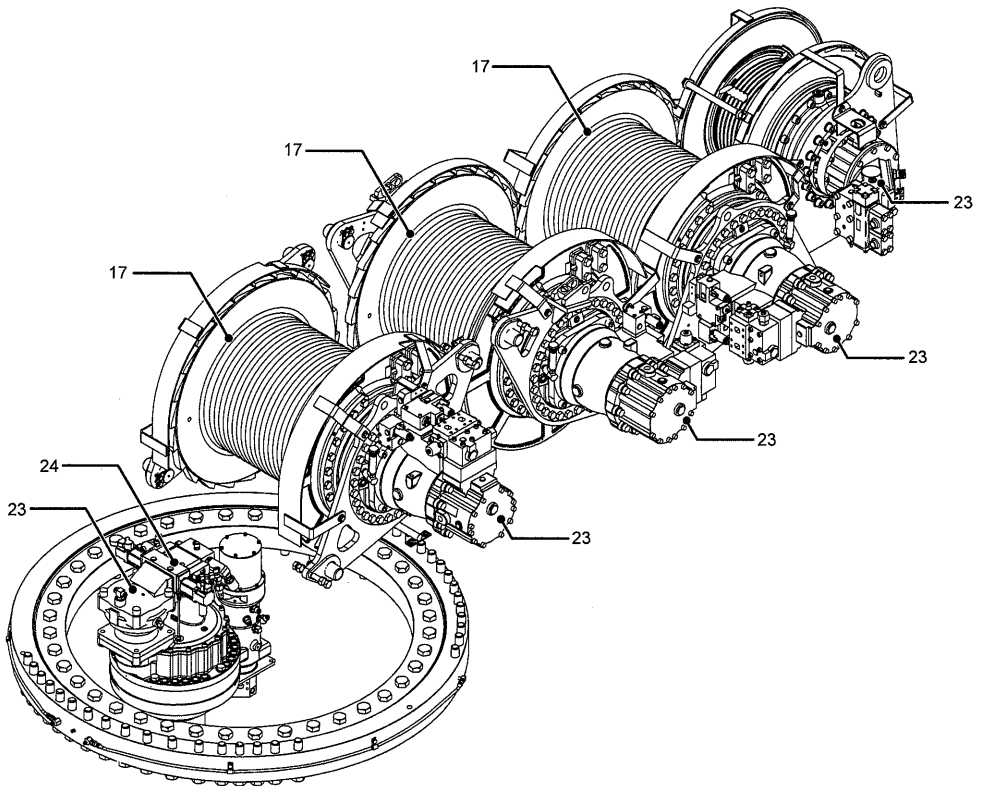

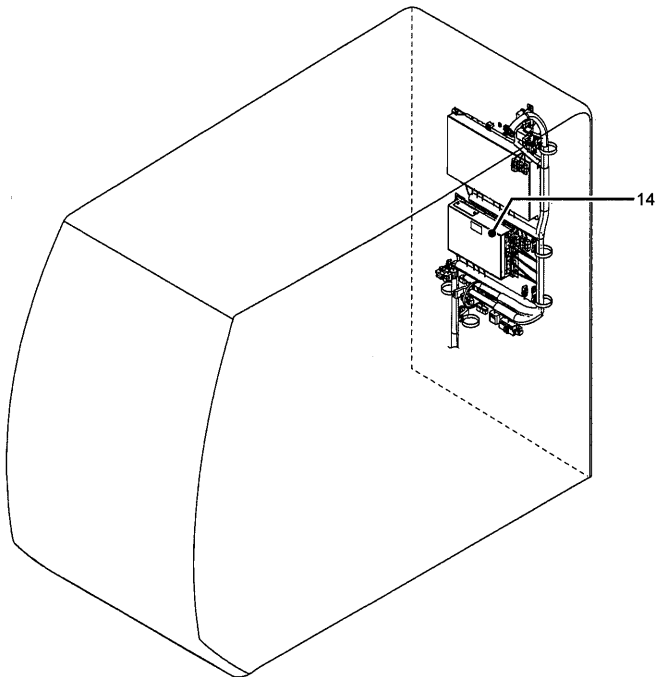
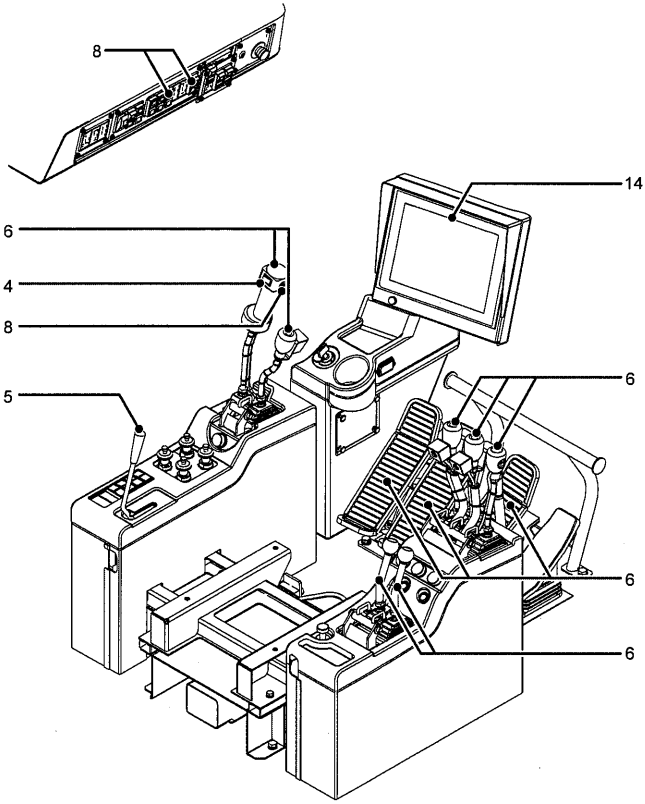

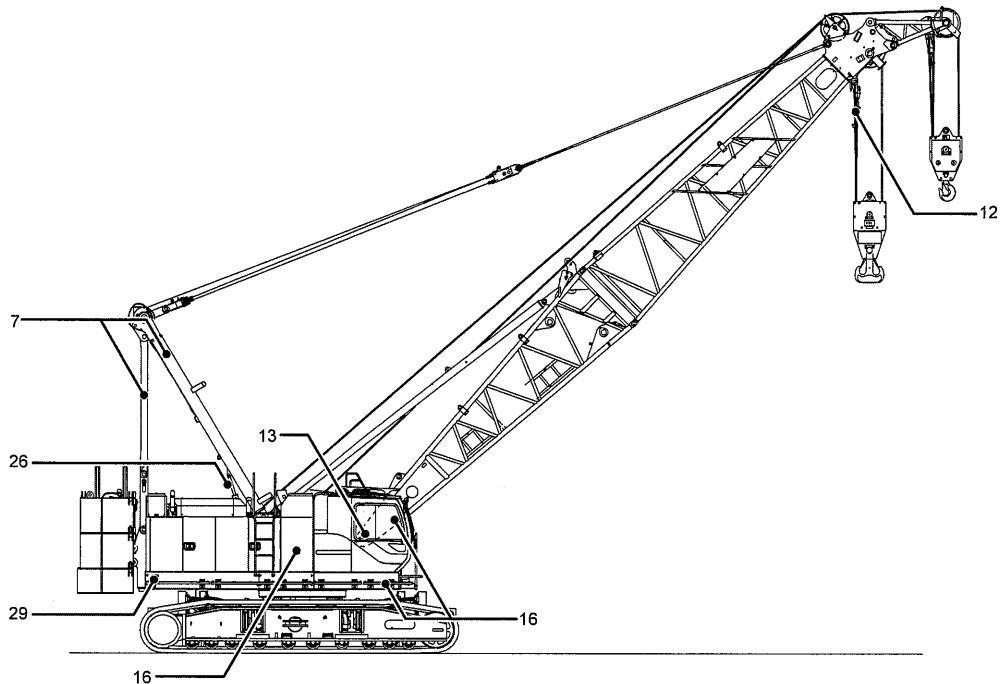

7

Check interval	Identification	Check item	Check method	Reference page
Daily or every 8 hours (Every shift)	1. FUEL AND HYDRAULIC LINES	Damage	Visual check	P.7-26
	2. ENGINE	Starting, leak, unusual noise	Starting, check by hearing	P.7-26
	3. HOSE, PIPING AND CONNECTOR	Oil leak	Visual check	P.7-26
	4. SWING BRAKE	Effectiveness	Operation	P.7-26
	5. SWING LOCK	Performance	Operation	P.7-27
	6. CONTROL LEVER, BRAKE PEDAL	Play, deformation	Operation, visual check	P.7-27
	7. GANTRY	Deformation, crack	Visual check	P.7-27
	8. HORN, WORK LIGHT AND WIPER	Performance	Operation, visual check	P.7-27
	9. AIR CLEANER	Missing (indicator)	Visual check	P.7-28
	10. PIN, LINK AND COTTER PIN	Damage, missing	Visual check	P.7-28
	11. BOLT AND NUT	Looseness, missing	Visual check	P.7-28
	12. HOOK OVERHOIST PREVENTIVE DEVICE	Performance	Operation	P.7-28
	13. BOOM OVERHOIST PREVENTIVE DEVICE	Performance	Operation	P.7-28
	14. LOAD SAFETY DEVICE, MONITOR	Performance	Operation	P.7-28
	15. DRUM LOCK	Performance	Operation	P.7-29
	16. WINDOW GLASS, STEP, HANDLE AND GUARD	Damage, crack, missing	Visual check	P.7-29
	17. DRUM BRAKE DISK (FRONT AND REAR)	Wear (indicator)	Visual check	P.7-30
Weekly or every 50 hours	18. FUEL PRE-FILTER	Water level	Visual check	P.7-31

* The item numbers in the above table correspond to the numbers in the following description.

* The item numbers, 3, 10, 11 are not indicated in the drawing.

Check interval	Identification	Check item	Check method	Reference page
Monthly or every 100 hours	19. FAN BELT	Looseness, damage	Push with finger, visual check	P.7-32
	20. RADIATOR AND OIL COOLER	Oil leak, damage	Visual check	P.7-33
	21. ENGINE MOUNTING BOLT AND RUBBER MOUNT	Looseness, damage	Visual check, test hammer	P.7-34
	22. POWER DIVIDER	Oil leak, unusual noise	Visual check, check by hearing	P.7-34
	23. HYDRAULIC MOTOR AND REDUCTION UNIT	Oil leak, unusual noise	Visual check, check by hearing	P.7-35
	24. VALVE, ETC.	Oil leak	Visual check	P.7-35
	25. HYDRAULIC PUMP	Oil leak, unusual noise	Visual check, check by hearing	P.7-36
	26. GANTRY CYLINDERS	Oil leak, damage	Visual check	P.7-36
	27. DRUM LOCK	Wear, damage	Visual check	P.7-36
	28. FUEL SUPPLY PUMP AND HOSE (OPTION)	Performance, damage	Operation, visual check	P.7-37
Semi-annually or every 500 hours	29. SWING ALARM	Alarm sound, lamp	Operation, visual check	P.7-37
	30. ACCUMULATOR	Oil leak, damage	Visual check	P.7-38
	31. SWING FRAME	Damage, crack	Visual check	P.7-38

* The item numbers in the above table correspond to the numbers in the following description.

7.2.2 INSPECTION OF LOWER MACHINERY

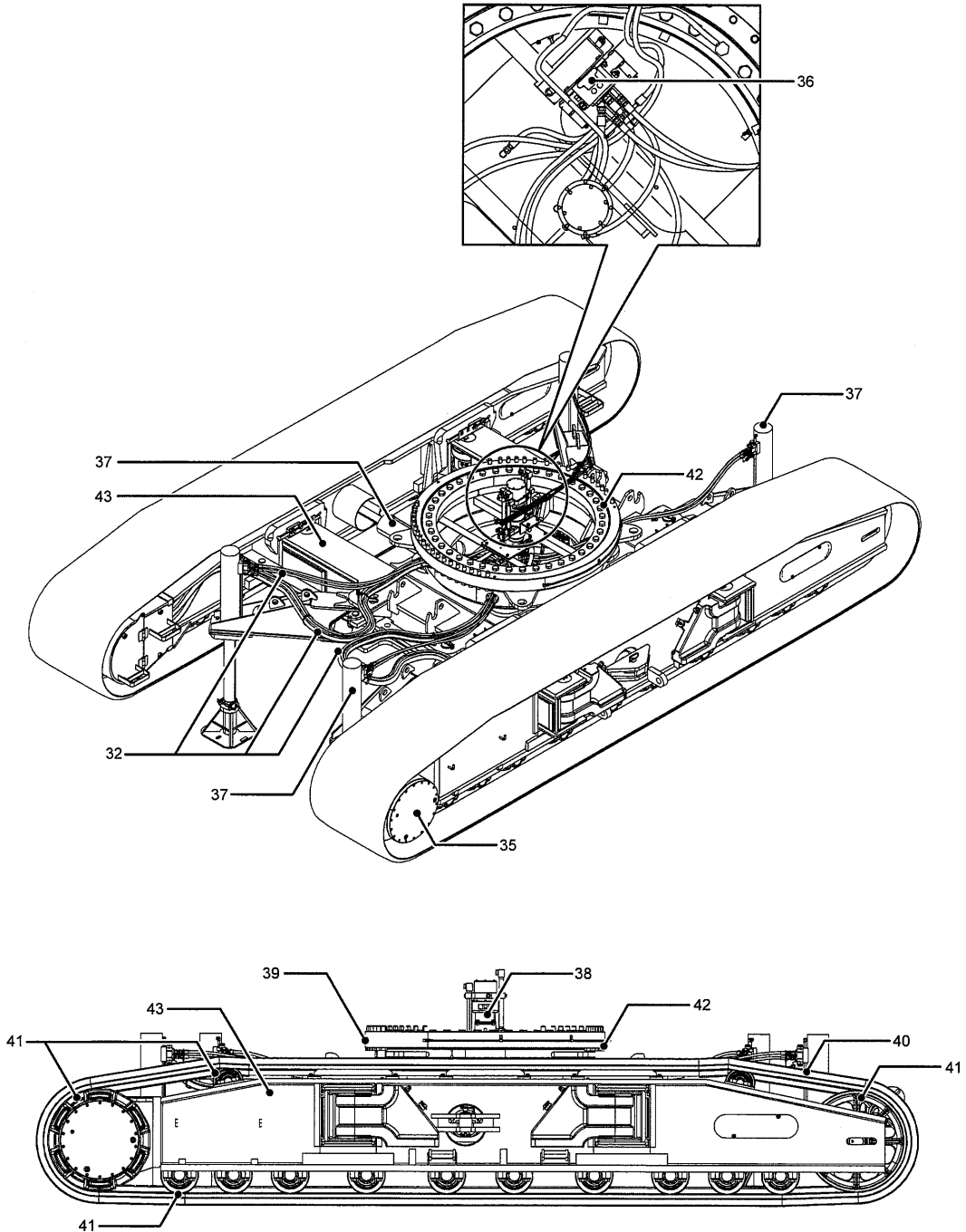

Check interval	Identification	Check item	Check method	Reference page
Daily or every 8 hours (Every shift)	32. HOSE, PIPING AND CONNECTOR	Oil leak, damage	Visual check	P.7-39
	33. PIN, LINK AND COTTER PIN	Damage, missing	Visual check	P.7-39
	34. BOLT AND NUT	Looseness, missing	Visual check	P.7-39
Monthly or every 100 hours	35. HYDRAULIC MOTOR AND REDUCTION UNIT	Oil leak, unusual noise	Visual check	P.7-39
	36. VALVE, ETC.	Oil leak	Visual check	P.7-39
	37. CRAWLER EXTEND/RETRACT CYLINDER, TRANSLIFTER CYLINDER	Oil leak, damage	Visual check	P.7-39
	38. SWIVEL JOINT	Oil leak	Visual check	P.7-40
	39. SLEWING BEARING	Unusual noise	Check by hearing	P.7-40
	40. CRAWLER SHOE	Extension, damage, wear	Visual check	P.7-40
Quarterly or every 250 hours	41. DRIVE TUMBLER, IDLER WHEEL AND UPPER/LOWER ROLLER	Oil leak, damage	Visual check	P.7-41
	42. SLEWING BEARING MOUNTING BOLT	Looseness, missing	Visual check	P.7-41
Semi-annually or every 500 hours	43. FRAME	Damage, crack	Visual check	P.7-42

* The item number in the above table correspond to numbers in the following description.

* The item numbers, 33, 34 are not indicated in the drawing.

7.2.3 INSPECTION OF ATTACHMENT

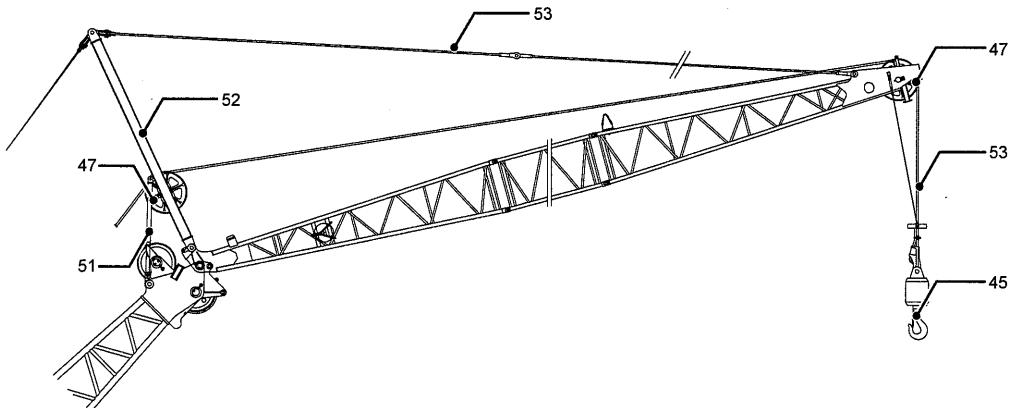
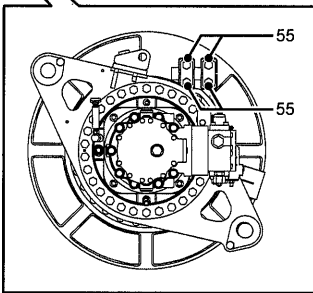
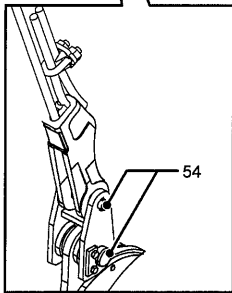
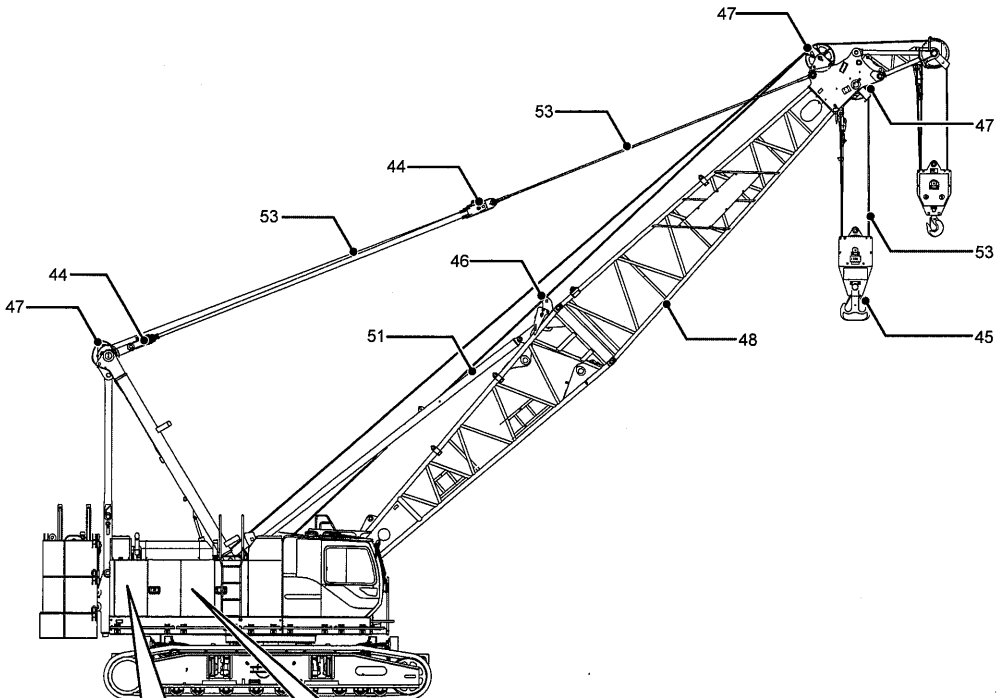

Check interval	Identification	Check item	Check method	Reference page
Daily or every 8 hours (Every shift)	44. UPPER SPREADER AND LOWER SPREADER	Deformation, crack	Visual check	P.7-43
	45. HOOK AND LATCHES	Damage, looseness	Visual check	P.7-43
	46. CABLE ROLLER AND GUIDE ROLLER	Damage, deformation, wear	Visual check	P.7-44
	47. SHEAVE	Damage, deformation, wear	Visual check	P.7-44
	48. BOOM AND JIB	Damage, deformation	Visual check	P.7-44
	49. PIN, LINK AND COTTER PIN	Damage, missing	Visual check	P.7-44
	50. BOLT AND NUT	Looseness, missing	Visual check	P.7-44
	51. BACKSTOP	Damage, deformation	Visual check	P.7-45
	52. STRUT	Damage, deformation	Visual check	P.7-45
	53. WIRE ROPE AND GUY LINE	Damage, deformation, wear	Visual check	P.7-46
	54. LOAD DETECTOR ROPE SOCKET PIN, BOLT, NUT	Looseness, missing	Visual check	P.7-46
55. HOIST WIRE ROPE CLAMP BOLT	Looseness, missing	Visual check	P.7-46	

* The item number in the above table correspond to numbers in the following description.

* The item numbers 49, 50 are not indicated in the drawing.

7.2.4 INSPECTION METHOD OF EACH POINT

CHECK OF UPPER MACHINERY

(Refer to P.7-15 to P.7-19)

CHECK OF UPPER MACHINERY, DAILY OR EVERY 8 HOURS (EVERY SHIFT)

1. FUEL AND HYDRAULIC LINES

Check the fuel and hydraulic lines for damage and leak.



If fuel leak is observed, repair leak and remove excess fuel immediately.
Failure to observe this precaution may result in a serious accident.

2. ENGINE

Start the engine to confirm proper starting condition and listen for unusual noise.

3. HOSE, PIPING AND CONNECTOR

Check the hose, piping and connector, etc. for oil leaks and damage.

4. SWING BRAKE

Confirm that the swing brake is functioning properly.

With the swing brake switch placed in the ON position, operate the swing control lever to confirm that the swing brake is functioning properly.

When the swing brake is engaged, swinging is not possible.

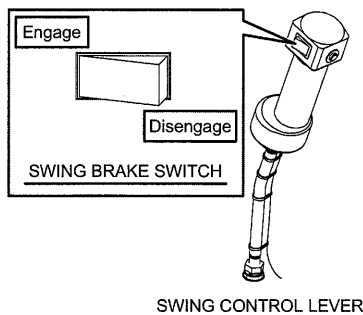

5. SWING LOCK

Confirm that the swing lock pin is inserted smoothly and can be held being pulled out. Check the lock pin and rod for deformation.

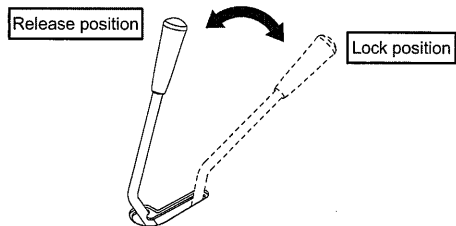

SWING LOCK CONTROL LEVER

6. CONTROL LEVER, BRAKE PEDAL

Check the control lever and brake pedal for unusual play and for damage.

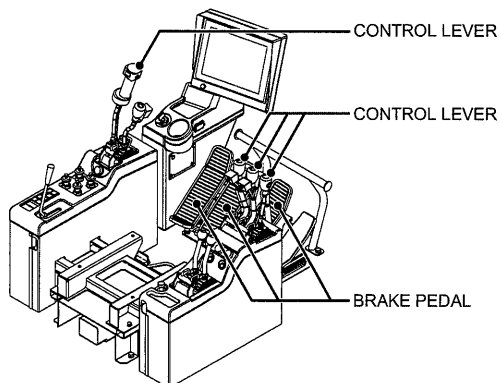

7. GANTRY

Check the gantry for damage.



Special repair procedures are required for repair. Consult your local authorized KOBELCO distributor for instructions.

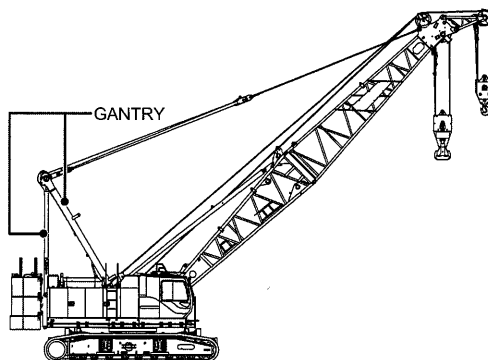

8. HORN, WORK LIGHT AND WIPER

Confirm that the horn, work light and wiper operate normally by operating the switches.

9. AIR CLEANER

Use the sensor to determine if the air cleaner is clogged.

When the air cleaner is clogged the error code will be indicated on the monitor as below.

Clogging of air element is detected with air cleaner sensor.

When clogging occurs, warning  is displayed on the monitor.

Clean or replace element.

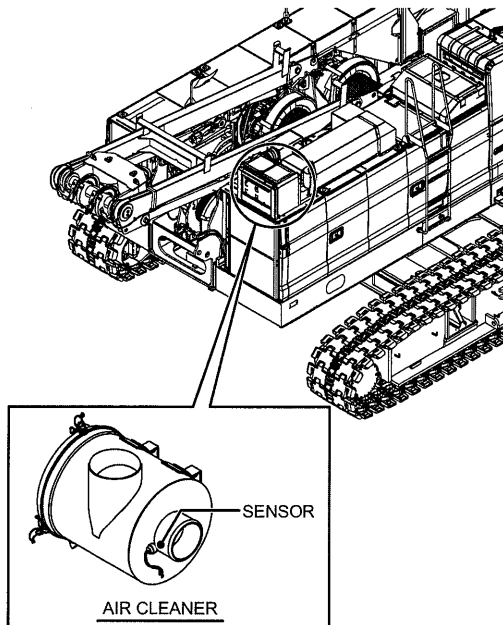

10. PIN, LINK AND COTTER PIN

Check the pin, link and cotter pin for damage and to determine if they are loose or missing.

11. BOLT AND NUT

Check the bolt and nut to determine if they are loose or missing.

12. HOOK OVERHOIST PREVENTIVE DEVICE

Confirm that the hook overhoist preventive device operates normally.

(Refer to the article 3 "LOAD SAFETY DEVICE")

13. BOOM OVERHOIST PREVENTIVE DEVICE

Confirm that the boom overhoist limit switch operates normally.

(Refer to the article 3 "LOAD SAFETY DEVICE")

14. LOAD SAFETY DEVICE, MONITOR

Confirm that operation is automatically stopped.

(Refer to the article 3 "LOAD SAFETY DEVICE")

15. DRUM LOCK

Confirm that the drum lock functions normally.
Pull up the drum lock knob to "LOCK" side and confirm that the pawl is engaged.

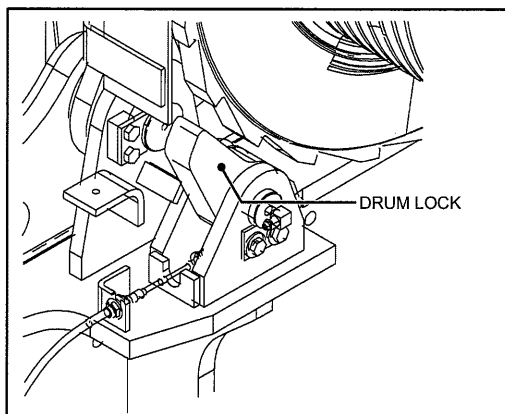
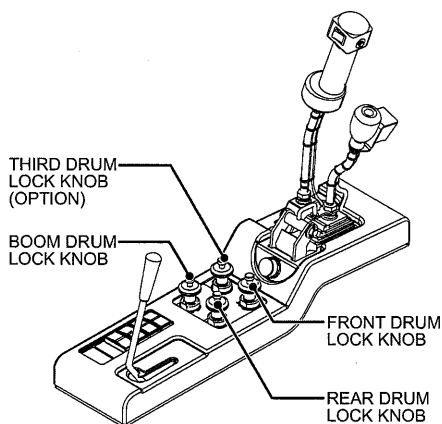

16. WINDOW GLASS, STEP, HANDLE AND GUARD

Always clean the window glass, step, handle and guard, etc.
Immediately remove any grease and oil.

17. DRUM BRAKE DISK (FRONT AND REAR)

Check the wear of the brake disk with the indicator. If the "FREE FALL" mode is selected, the indicator is protruded by approx. 21 mm (13/16 in.).

Stop the engine and press the indicator.

If the indicator protrudes from the end face by approx. 8 mm (5/16 in.), the brake disk is normal.

If the protruded length of the indicator is 5 mm (3/16 in.) or shorter (Indicator recess disappears), raising may become difficult. In such a case, replace the brake disk by contacting your nearest KOBELCO authorize distributor.

⚠ DANGER

Be sure to lower the hook block onto the ground to prevent it from dropping abruptly. Failure to observe this precaution may result in a serious accident.

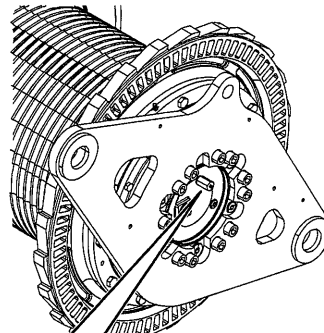

(Right side view)

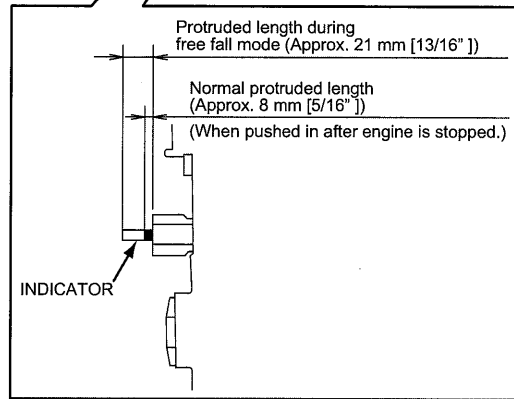

CHECK OF UPPER MACHINERY, WEEKLY OR EVERY 50 HOURS**18. FUEL PRE-FILTER****• Drain water from fuel pre-filter**

If the red ring (a) of the pre-filter is on the bottom of the case (b), water does not get in.

When the red ring (a) floats, drain the water in accordance with the following procedures.

- (1) Place a container to receive the drained water under the drain hose.
- (2) Loosen the water draining plug (c) of the fuel pre-filter to drain water accumulated at the bottom of the fuel pre-filter case.
- (3) Tighten the water draining plug (c).
- (4) Actuate the priming pump and bleed air from the fuel system.

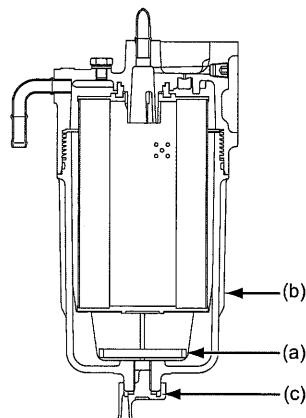
**CAUTION**

Drained water contains fuel, therefore, follow the processing regulation specified in each region, when disposing.

**CHECK OF UPPER MACHINERY, MONTHLY
OR EVERY 100 HOURS**

19. FAN BELT

Check the fan belt for proper tension.

CAUTION

Turn the engine off before inspecting the fan belt.
Failure to observe this precaution may result in a
serious injury or loss of life.

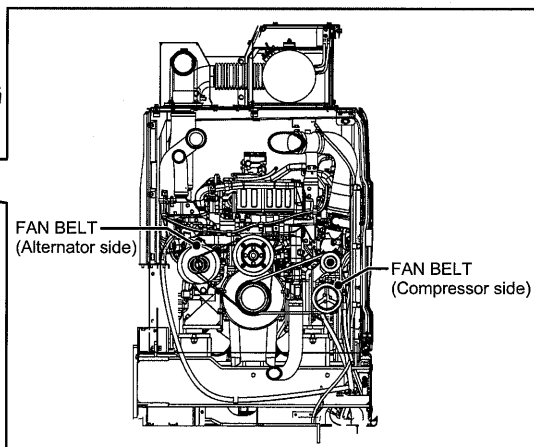
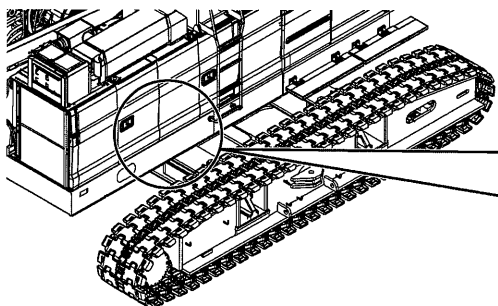

COMPRESSOR SIDE FAN BELT

Firmly press the middle of the fan belt with a finger.
Deflection of 10 to 15 mm (3/8 to 9/16 in.) is normal.

ALTERNATOR SIDE FAN BELT

The alternator side belt needs to be tension-adjusted more precisely than the compressor side belt. Rough target of deflection is 3 to 5 mm (1/8 to 3/16 in.) but use of the ultrasonic tension meter is recommended for checking.

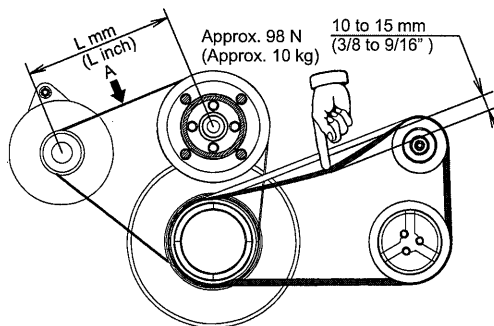

CAUTION

Inadequate tension may cause short life of
accessory or belt itself.
It may also cause belt to squeal.
Adjust tension adequately.

- **Checking method of tension**

- (1) Check "L" dimension in "A" area.
- (2) Turn the ultrasonic tension meter ON and input the unit weight.
(0.015 kg·m / 0.109 ft·lbs)
- (3) Input the number of belt crest.
- (4) Input the span length. (L mm / L inch)
- (5) Put the microphone of the ultrasonic tension meter near the measuring area A. With using a bar (extension bar) hit the A area of the belt with a specified force.
The ultrasonic tension meter reads the belt frequency and indicates it.
- (6) Repeat the above actions (5) for about five times and confirm that the average value is within the specified value range.

Specified tension value : 1,324 to 1,422 N
(135 to 145 kgf)

If not within the specified value, adjust the alternator belt tension.

7

 **CAUTION**

If the condition as listed below occurs, replace the belt with a new one.

- **Belt squeals occur even after the belt is adjusted properly.**
 - **Crack or damage found on the belt.**
If the belt is over-used, belt may break and may cause damage to the other parts.
Replace the failed belt.
-

20. RADIATOR AND OIL COOLER

Clean the radiator core.

Check the radiator and oil cooler for abnormalities such as water leak, oil leak or deformation.

Radiator core clogging may cause engine over-heat.

Take care not to damage the core while cleaning the radiator core.

21. ENGINE MOUNTING BOLT AND RUBBER MOUNT

Check the engine mounting bolt for looseness, and the rubber mount for damage.

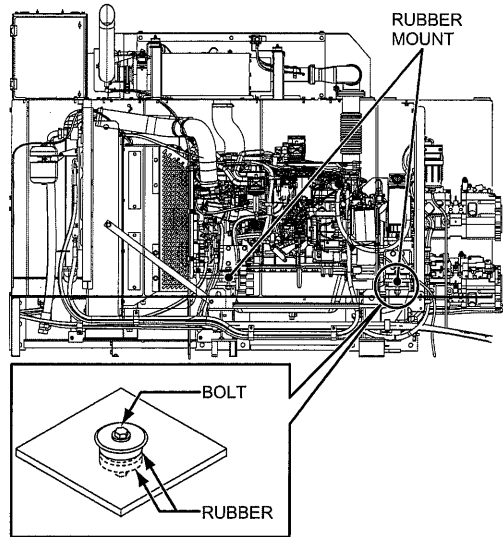

22. POWER DIVIDER

Check the power divider for oil leak and unusual noise.

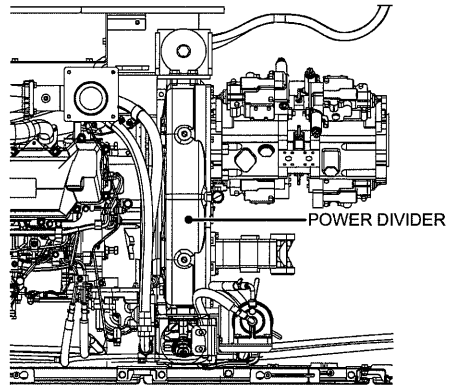

23. HYDRAULIC MOTOR AND REDUCTION UNIT

- Swing motor and reduction unit.
 - Front and rear drum motors and reduction units.
 - Boom hoist drum motor and reduction unit.
- Check these for oil leak and unusual noise.

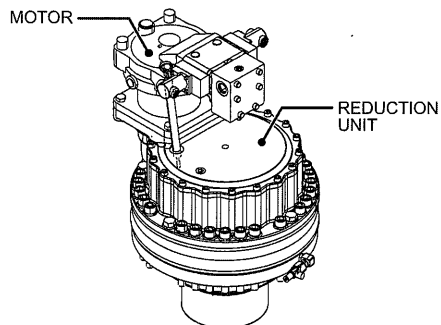
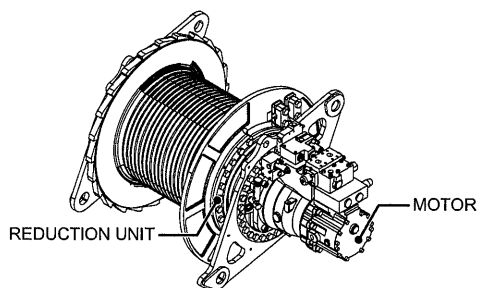
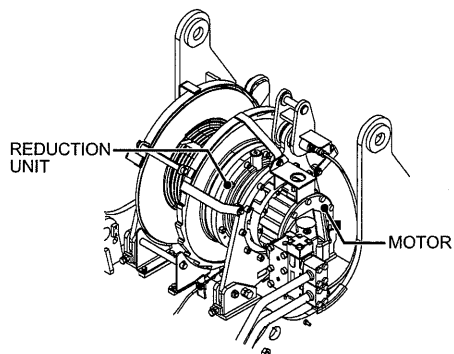
SWING MOTOR AND REDUCTION UNITFRONT, REAR DRUM MOTOR AND REDUCTION UNITBOOM HOIST DRUM MOTOR AND REDUCTION UNIT**24. VALVE, ETC.**

Check each valve for oil leak.

25. HYDRAULIC PUMP

Check the hydraulic pump for oil leak and for unusual noise.

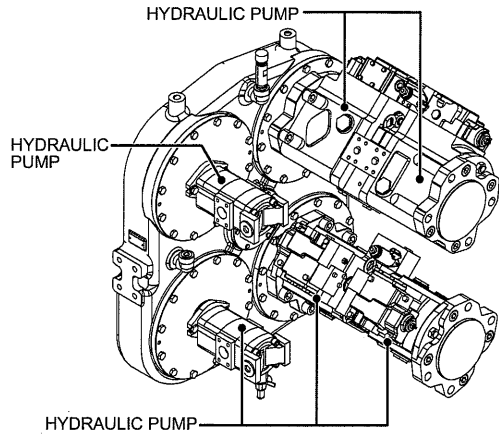

26. GANTRY CYLINDERS

Check the gantry cylinder for oil leak and damage.

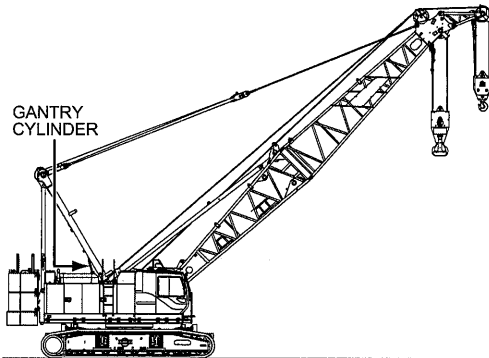

27. DRUM LOCK

Check the drum lock and drum ratchet for wear and damage.

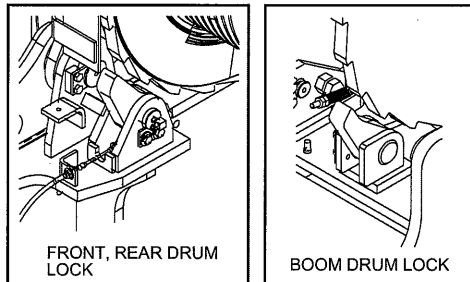

28. FUEL SUPPLY PUMP AND HOSE (OPTION)

Check the fuel supply pump for normal operation, and check the supply hose for damage.

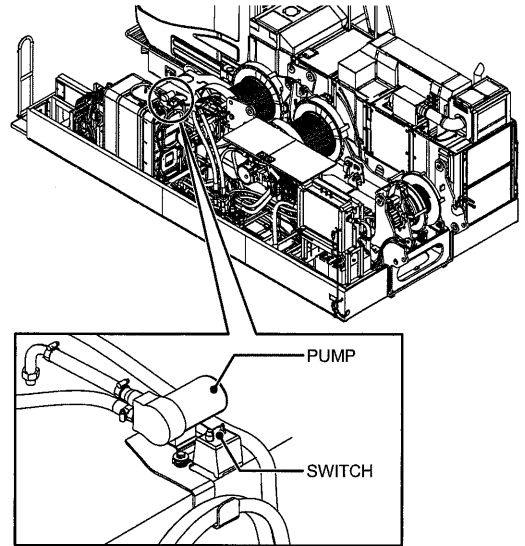
**29. SWING ALARM**

Make sure that the swing alarm and swing flasher on left and right rear of main machinery function properly when swinging for check.

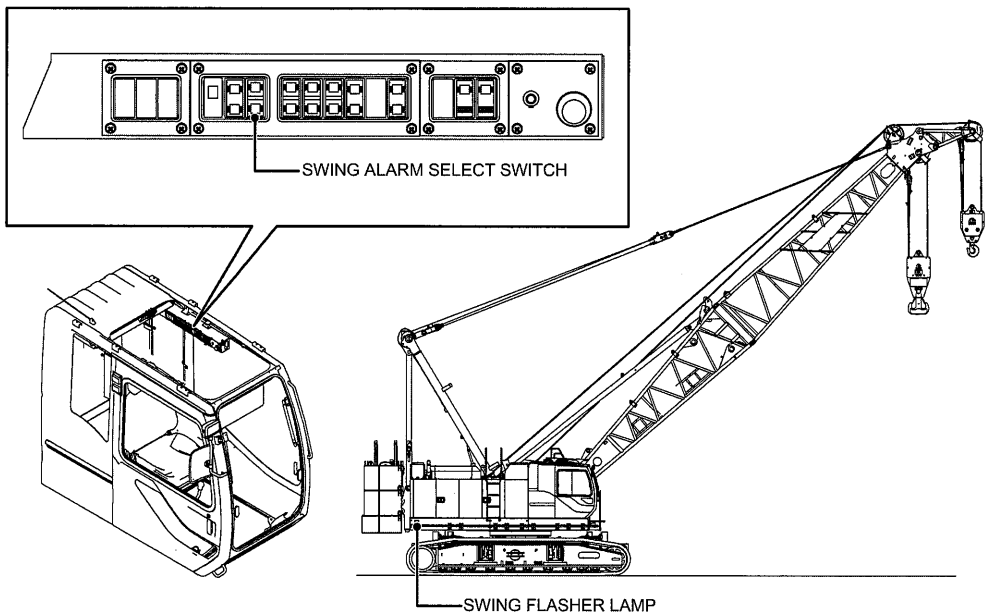

**CHECK OF UPPER MACHINERY,
SEMI-ANNUALLY OR EVERY 500 HOURS**

30. ACCUMULATOR

Check the accumulator for oil leak.

⚠ WARNING

- Do not handle the accumulator roughly.
- Do not store or handle the accumulator near the heat of fire.
- Do not weld or machine the accumulator.
- Do not remove valve cap except when charging or discharging gas.
- Do not step on or place heavy material on the accumulator installed on the machine.
- Check the accumulator for gas pressure every two years.
- Ask KOBELCO authorize distributor to charge the gas.
- Do not disassemble the accumulator.

The accumulator is charged with Nitrogen gas under pressure of 3.4 to 3.7 MPa (493 to 537 psi).

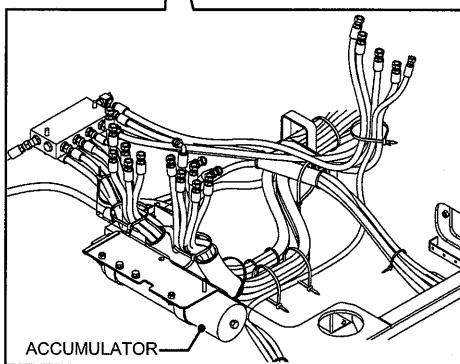
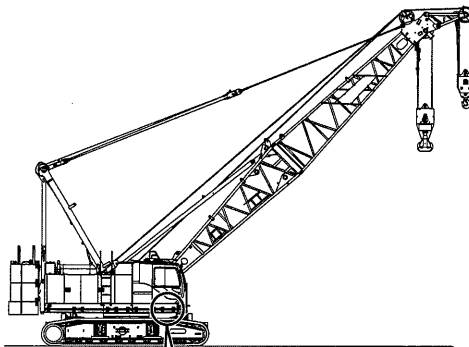

31. SWING FRAME

Check the swing frame for crack and deformation.

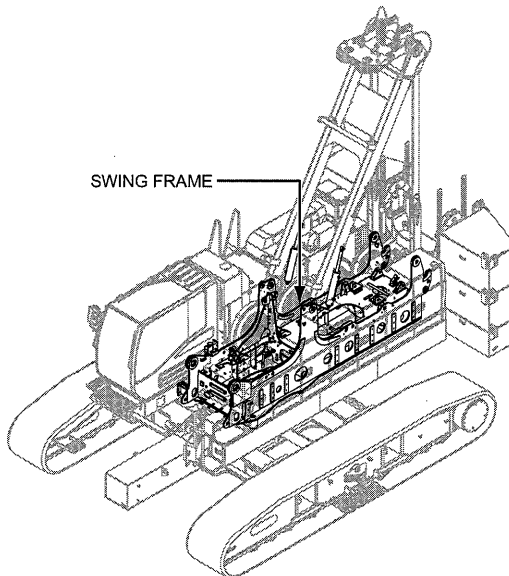

CHECK OF LOWER MACHINERY

(Refer to P.7-22 to P.7-23)

CHECK OF LOWER MACHINERY, DAILY OR EVERY 8 HOURS (EVERY SHIFT)**32. HOSE, PIPING AND CONNECTOR**

Check the hose, piping and connector, etc. for oil leak and damage.

33. PIN, LINK AND COTTER PIN

Check the pin, link and cotter pin for damage, and for missing.

34. BOLT AND NUT

Check the bolt and nut for looseness and for missing.

CHECK OF LOWER MACHINERY, MONTHLY OR EVERY 100 HOURS**35. HYDRAULIC MOTOR AND REDUCTION UNIT**

Check the hyd. motor and reduction unit for oil leak and unusual noise.

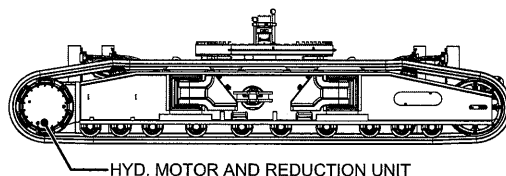
**36. VALVE, ETC.**

Check the valve, etc. for oil leak.

37. CRAWLER EXTEND/RETRACT CYLINDER, TRANSLIFTER CYLINDER

Check the crawler extend/retract cylinder and the translifter cylinder for oil leak and damage.

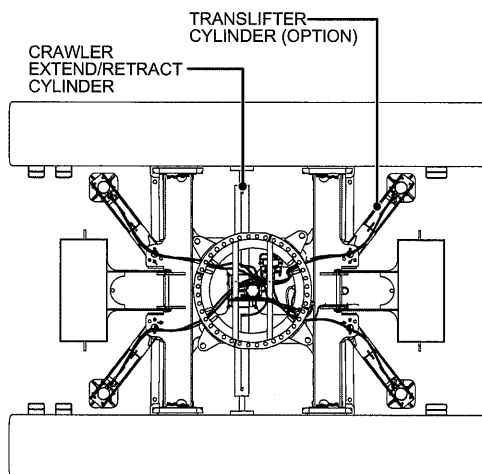

38. SWIVEL JOINT

Check the swivel joint for oil leak.

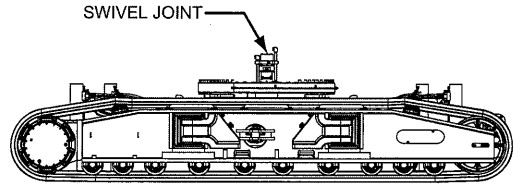

39. SLEWING BEARING

Check the slewing bearing for unusual noise.

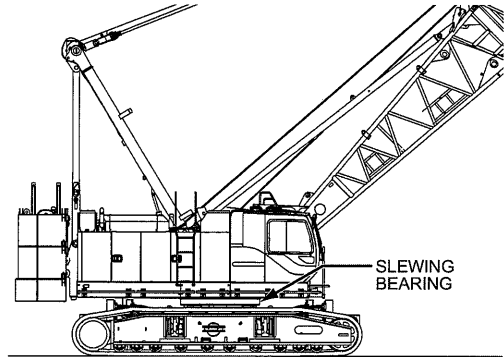

40. CRAWLER SHOE

Check the crawler shoes for looseness, damage and wear.

If the crawler tension is too high, the shoes wear quickly and a connection part of shoes could break.

On the other hand, if the crawler tension is too loose, the shoes may ride off the drive tumbler or idler wheel during propelling.

The slackening of 10 to 20 mm (3/8 to 13/16 in.) is normal condition after propelling the machine forward about the crawler length when measuring at the upper side of the crawler.

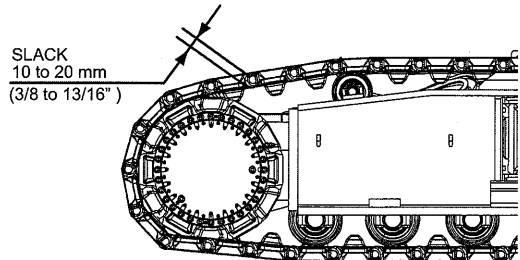
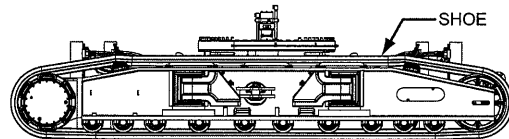

CHECK OF LOWER MACHINERY, QUARTERLY EVERY 3 MONTHS OR EVERY 250 HOURS

41. DRIVE TUMBLER, IDLER WHEEL AND UPPER/LOWER ROLLER

Check the drive tumbler, idler wheel and upper/lower rollers for oil leak and damage.

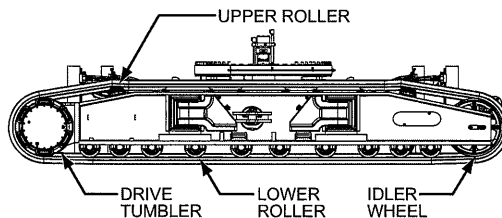

42. SLEWING BEARING MOUNTING BOLT

Check the slewing bearing mounting bolt for looseness and missing.

Remove the upper and lower covers of the swing frame for the inner bolt checking.

If the bolt is loose, remove and check it.

And if it is damaged, replace it with new one.

If the removed bolt is not damaged, clean and coat it with LOCTITE #242 or #243 or equivalent, then securely tighten it.

TIGHTENING TORQUE

Outer bolt	2,780 N·m (2,050 ft·lbs)
Inner bolt	2,780 N·m (2,050 ft·lbs)

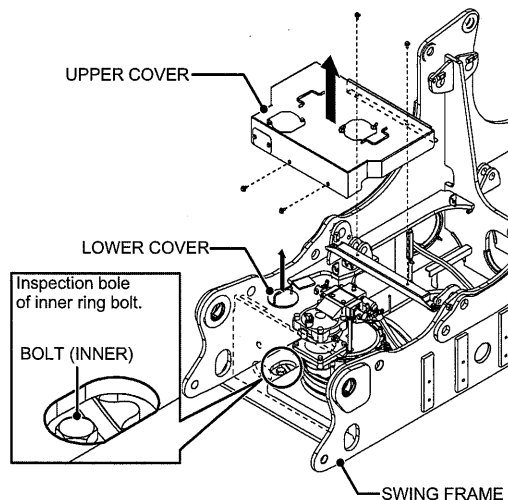
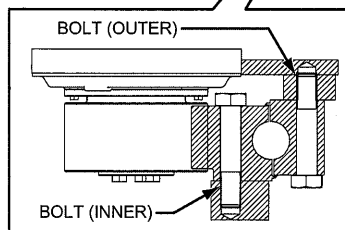
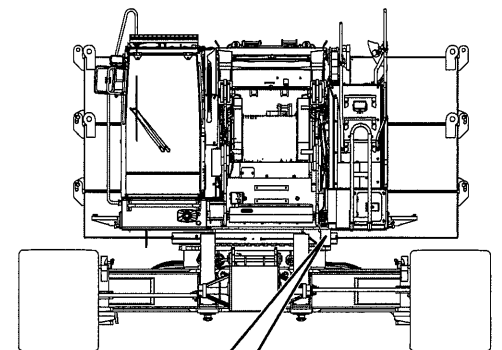

7

**CHECK OF LOWER MACHINERY,
SEMI-ANNUALLY OR EVERY 500 HOURS**

43. FRAME

Check the carbody and crawler frame for crack and damage.

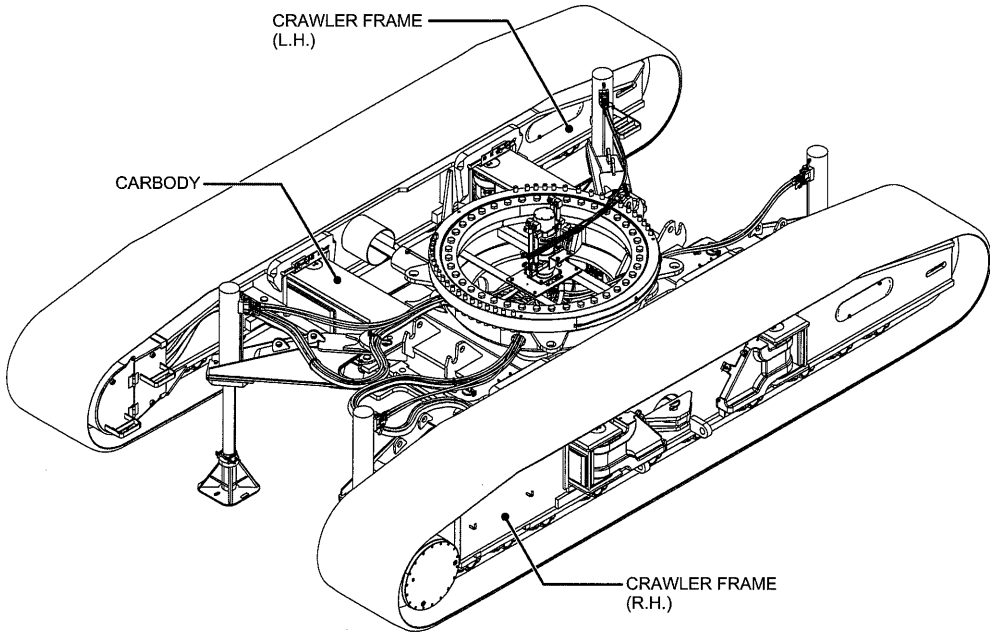

CHECK OF ATTACHMENT

(Refer to P.7-24 to P.7-25)

CHECK OF ATTACHMENT DAILY OR EVERY 8 HOURS (EVERY SHIFT)**44. UPPER SPREADER AND LOWER SPREADER**

Check the sheave and frame of the upper and lower spreaders for damage.

WARNING

Do not touch a wire rope directly with bare hands. If wires protrude, you could be injured.

Working gloves are recommended.

Failure to observe this precaution may result in a serious injury or loss of life.

WARNING

Before climbing on machine make certain that the guard and walk ways are clean and dry, and use safety belt in order to prevent falls due to slippery surface.

Failure to observe this precaution may result in a serious injury or loss of life.

45. HOOK AND LATCHES

Check the sheave, bearing and latches of the hook block for damage, and check the bolt and nut for missing.

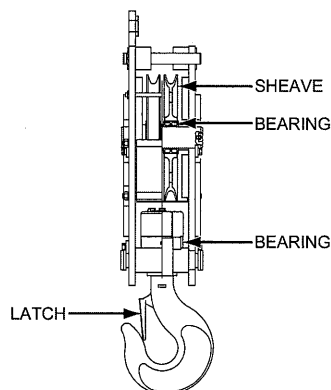

46. CABLE ROLLER AND GUIDE ROLLER

- Cable roller for boom insert
- Cable roller for boom tip
- Guide roller

Check these parts for damage, deformation and wear.

47. SHEAVE

- Boom point sheave
- Idler sheave
- Auxiliary sheave
- Jib point sheave
- Strut sheave
- Gantry peak sheave

Check these sheaves for damage, deformation and wear.

48. BOOM AND JIB

Check the boom and jib for damage and deformation.

Do not use the damaged and/or deformed boom and jib.

Be sure to replace the damaged boom and jib with new ones, or repair.

CAUTION

Due to the high strength steels used in boom and jibs, special repair procedures are required. Consult your local KOBELCO authorize distributor for instruction.

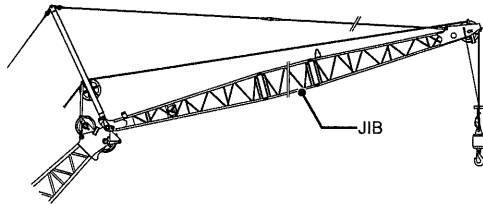
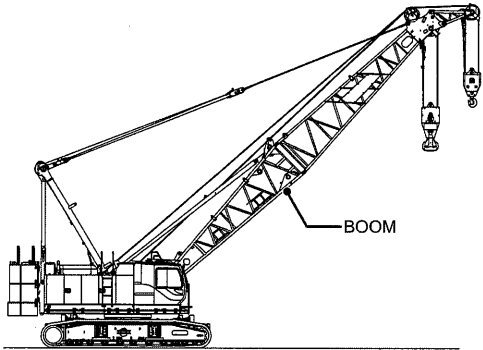

49. PIN, LINK AND COTTER PIN

Check the pin, link and cotter pin for damage and missing.

50. BOLT AND NUT

Check the bolt and nut for looseness and missing.

51. BACKSTOP

- Boom backstop
- Strut backstop

Check these backstops for damage and deformation.

CAUTION

Special procedures required for repair.
Consult your local KOBELCO authorize distributor
for instruction.

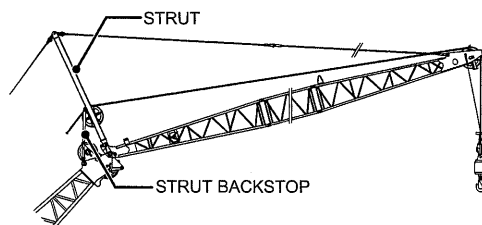
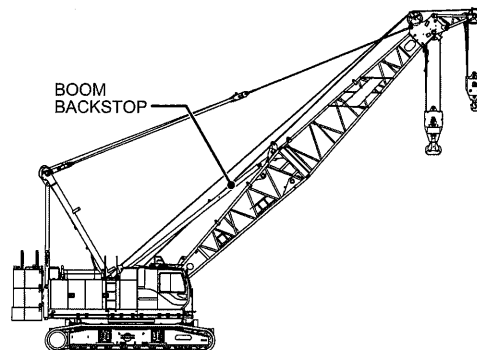

7

52. STRUT

Check the jib strut for damage, deformities and usual play.

CAUTION

Special procedures required for repair.
Consult your local KOBELCO authorize distributor
for instruction.

53. WIRE ROPE AND GUY LINE

Check the wire rope and guy line for damage and deformation and wear.

Signs are ; Kink, Crushing, Unstranding, Birdcage, Core Failure / Protrusion, Significant corrosion, Electric arc damage.

Also inspect socket and end conditions.

Do not use the wire rope and guy line sustaining damages beyond regulations described.

Refer to the article 6. "WIRE ROPE".

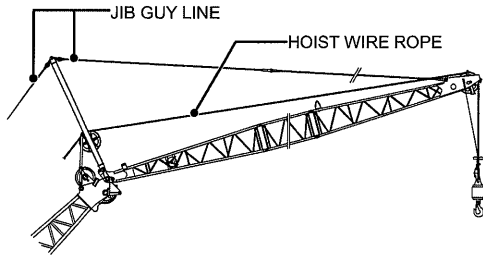
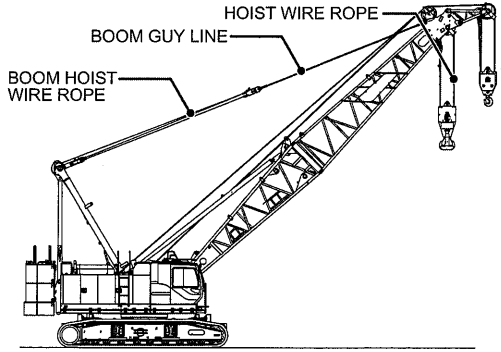

54. LOAD DETECTOR ROPE SOCKET PIN, BOLT, NUT

Check for the looseness and missing of pin, bolt, nut.

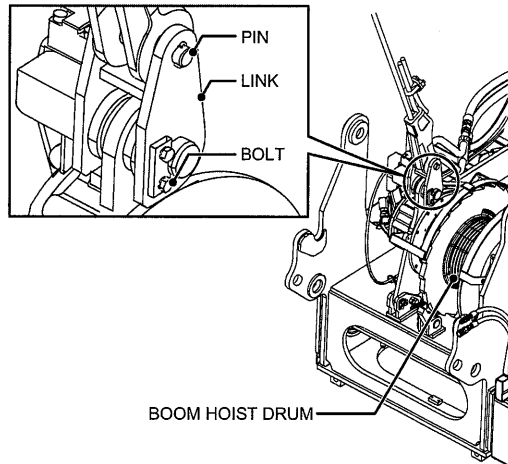

55. HOIST WIRE ROPE CLAMP BOLT

Ensure that the bolts securing the hoist wire rope to the drum flange are securely tightened, and the painted section of the wire rope is correctly positioned.

Tightening torque : 373 N·m (275 ft·lbs)

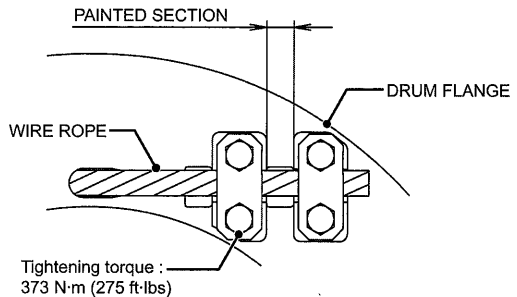

HOOK AND SHACKLE MAINTENANCE STANDARD

The operating condition of main and aux. hook can change daily with use; therefore, they must be inspected daily (at start of each shift) and observed during operation for any defects which could affect their safe operation.

Correct all defects before using the hook block or ball hook.

Daily inspection and maintenance will include the following points.

- (1) Clean the hook block or the ball hook.
- (2) Lubricate the sheaves (if fittings provided), the hook swivel, and any other part equipped with a grease fitting at the intervals specified in the "32. HOOK SHEAVE" (P.7-80).
- (3) Tighten loose tie-bolts, capscrews, and setscrews.

Check that all cotter pins are installed and opened.

- (4) Check the sheaves for uneven wear in the grooves and on the flanges.

Check for loose or wobbly sheaves.

These conditions indicate faulty bearings or bushings.

- (5) Check the fit of the wire rope in the groove of each sheave.

An oversize wire rope can crack the lip of the sheave flange causing rapid wear of the wire rope and sheave.

The groove must be larger than the wire rope, and the groove must be free of rough edges and burrs.

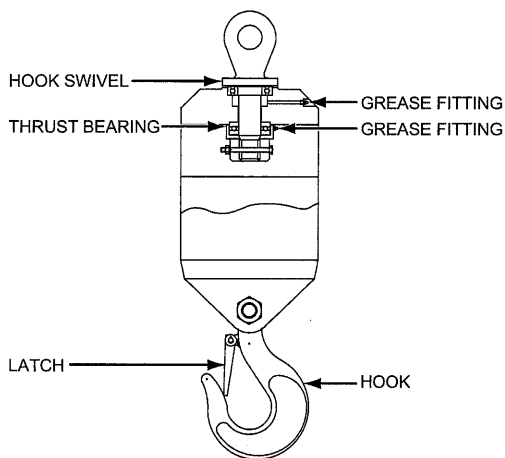
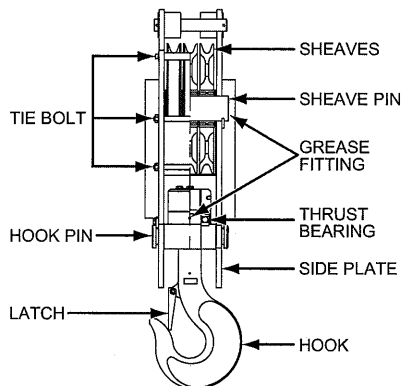

7

Note

Rope groove dia. shall be about 10% larger than rope nominal dia..

Take extra care since, larger or smaller dia. groove may cause premature damage of the rope.

- (6) Check that the hook, the trunnion, and the swivel rotate freely without excessive play.
Faulty operation indicates faulty bushings or bearings or inadequate lubrication.
- (7) Check the swivel of the hook for the following conditions :
Overloading : Spin the swivel by hand; if the motion is rough or has a ratchet-like effect, the swivel bearings are damaged.
- (8) Check the main hook for signs of overloading: spread side plates, elongated holes, bent or elongated tie-bolts, and cracks.
- (9) Check the wire rope for wear and broken wires at the point the wire rope enters the dead-end socket.
Check the socket for cracks.
Tighten the wire-rope clips at the dead end of the wire rope.
- (10) Check that each hook is equipped with a hook latch and that the latch operates properly.
The latch must not be wired open or removed.

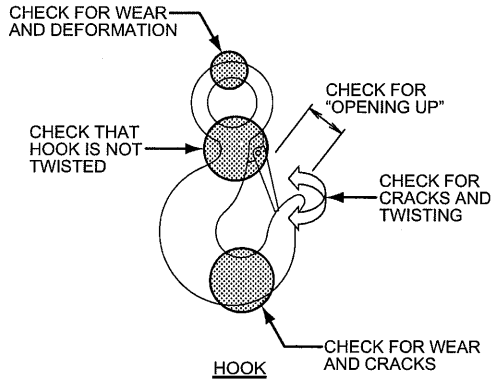
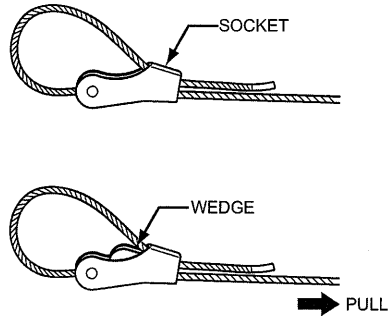

CAUTION

The latch must retain slings or other rigging in hook under slack conditions.
The latch is not intended as anti-fouling device, and caution must be taken to prevent hook latch from supporting any part of load.
Slings or other rigging must be seated in hook when handling load; they must never be in position to foul the latch.

(11) Inspect shackles for damage.

Note

Check each hook and shackle at least yearly for cracks using a dye penetrant test, MAG particle test, ultrasonic test, or by X-raying.

CAUTION

Do not attempt to repair cracks in hooks and shackles by welding.

Furthermore, do not weld on any load bearing component unless proper welding methods are used.

(Contact service department at factory for material and welding specifications.)

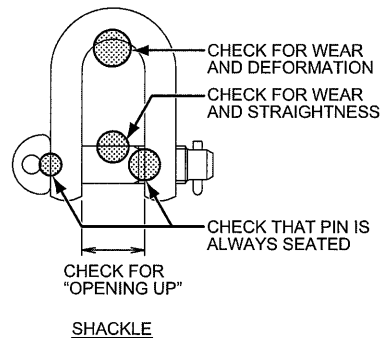

7.3 OIL/GREASE SUPPLY AND WATER SUPPLY

To ensure proper operation of this machine, all points requiring lubrication must be serviced with the correct lubricant (oil, grease and water) at the proper interval.

STANDARD OIL (WATER) SUPPLY CAPACITY TABLE (NOT INCLUDING GREASING POINT)

	Points of lubrication	Kind	Symbol	Capacity : L (gal)
Upper	Engine	Engine oil SAE #10W-30 (JASO : DH-2, API : CJ-4, ACEA E-6)	MO	28.5 (7.5)
	Radiator	Water (soft water)	—	34 (9.0)
	Fuel tank	ULTRA LOW SULFUR FUEL. Sulfur contained 50 ppm or less.	—	400 (105.6)
	Hydraulic oil tank	Hydraulic oil #32	HO	460 (121.5)
	Power divider	Gear oil #90	GO	10 (2.6)
	Front, rear drum reduction unit	Gear oil #80W-90	GO	22/each (5.8/each)
	Boom hoist drum reduction unit	Gear oil #90	GO	8 (2.1)
	Swing reduction unit	Gear oil #90	GO	16.5 (4.3)
Lower	Propel reduction unit	Gear oil #90	GO	25 (6.6)
	Idler wheel	Gear oil #140	GO	0.25/each (0.07/each)
	Lower roller	Gear oil #140	GO	0.13/each (0.03/each)
	Upper roller	Gear oil #140	GO	0.06/each (0.02/each)

WARNING

Use ultra low sulfur diesel fuel only (S50 : sulfur content lower than 50 ppm).

If fuel other than specified one is used, adverse affect may be caused to the engine or diesel particulate filter and white smoke or failure may be resulted.

CAUTION

In order to keep good function of the diesel particulate filter, it is recommended to use the specified brand (recommended) engine oil.

CAUTION

The radiator is supplied with coolant combined with "long life coolant (antifreeze)" of 30% to 50% concentration by volume.

KOBELCO GENUINE LUBRICANT CHART

Kind	Symbol	Specification	Part No.	
Hydraulic oil	HO	KW32S	20 L can →2421R157D3 (KAP YN01T01066D1)	200 L can →2421R157D4 (KAP YN01T01066D2)
Extreme pressure grease	EPG	—	2421Z183	
High temperature grease	HPG	—	2421Z183D2	
Molybdenum disulphide grease	GL	—	2421Z183D3	
Gear oil	GO	#90	20 L can → KSPS90020	200 L can → KSPS90200
		#80W-90	18 L can → GG01T01020D1	200 L can → GG01T01020D2
		#140	—	—
Engine oil	MO	SAE #10W-30 (DH-2, CJ-4, E-6)	20 L can → GG01T01047D1	200 L can → GG01T01047D2
Antifreeze	—	Long life coolant	18 L can → KSPLLC95-18	20 L can → KSPLLC95-20
		Permanent	18 L can → KSPPT95-18	20 L can → KSPPT95-20
Wire rope grease	—	Red	—	18 L can → KAPRR-1000
	—	Black	—	18 L can → KAPRB-1500

LUBRICATION CHART

Lubricant	Symbol	Recommended lubricant (Initial factory fill)			
Hydraulic oil	HO	Hydraulic oil with anti-wear, anti-oxidant an anti-harmful foaming			
		55°C to 5°C (131°F to 41°F)	40°C to 5°C (104°F to 41°F)	30°C to -25°C (86°F to -13°F)	15°C to -30°C (59°F to -22°F)
		ISO VG68	ISO VG46	ISO VG32	ISO VG22
Gear oil	GO	Extreme pressure gear oil #90 Grade GL-4 by API classification			
Grease	EPG	Extreme pressure Multipurpose grease NLGI No.2 Lithium base grease EP type			
	GL	NLGI No.1 Lithium base with MoS ₂ grease			
Engine oil	MO	Above 40°C (Above 104°F)	40°C to - 0°C (104°F to 32°F)	40°C to -30°C (104°F to -22°F)	
		SAE40	SAE30	SAE10W-30	

RECOMMENDED HYDRAULIC OIL

	VG32 KW32S	VG32 KW32	VG46 KW46	VG68 KW68
ESSO	—	NUTO H32	NUTO H46	NUTO H68
MOBIL	DTE 13	DTE 24	DTE 25	DTE 26
CALTEX	—	RANDO HD32	RANDO HD46	RANDO HD68
SHELL	—	TELLUS 32	TELLUS 46	TELLUS 68
GULF	—	HARMONY 32AW	HARMONY 46AW	HARMONY 68AW

Note

Under the extreme cold temperature (lower than -15°C [5°F]), use engine oil SAE10W.

Note

Listed oil specification may be changed without prior notice.

This page is blank for editing convenience.

7.3.1 UPPER LUBRICATION (INCL. WATER SUPPLY)

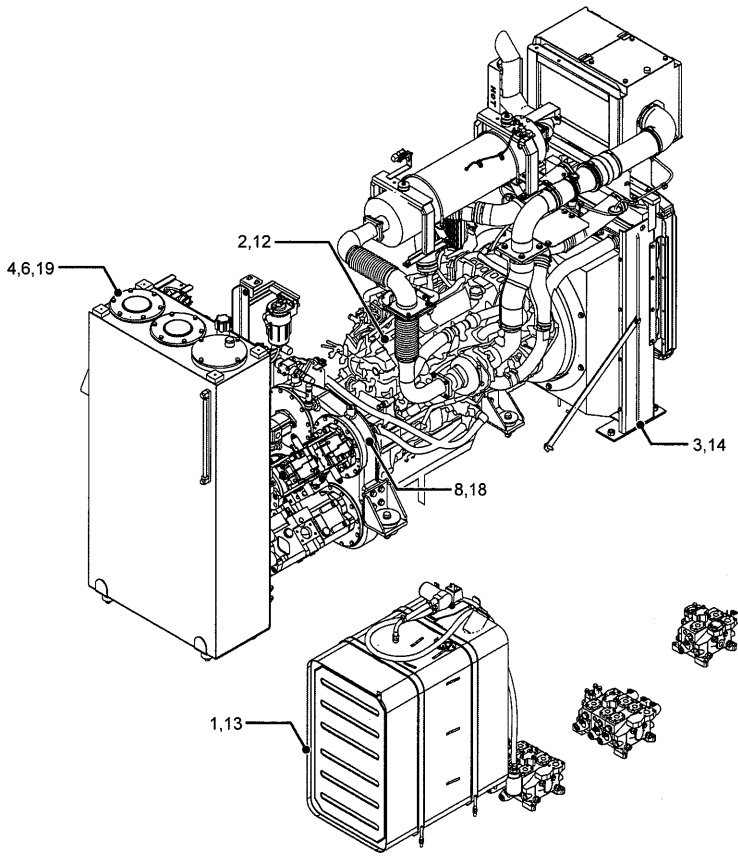
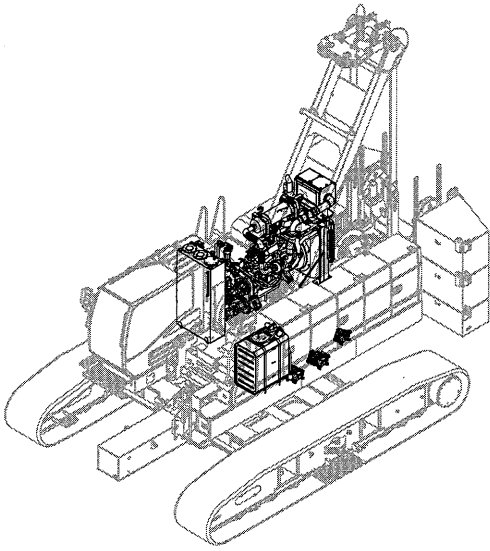

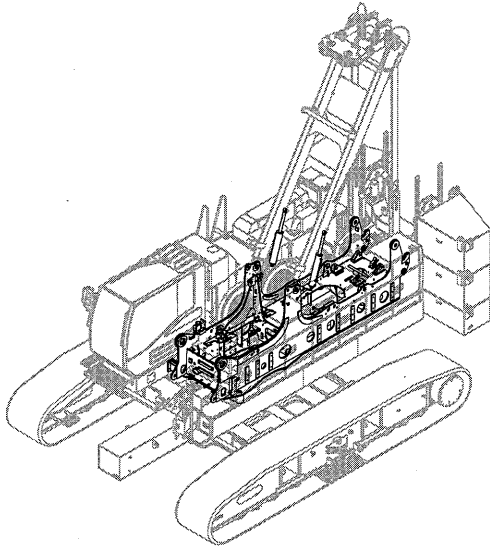

7

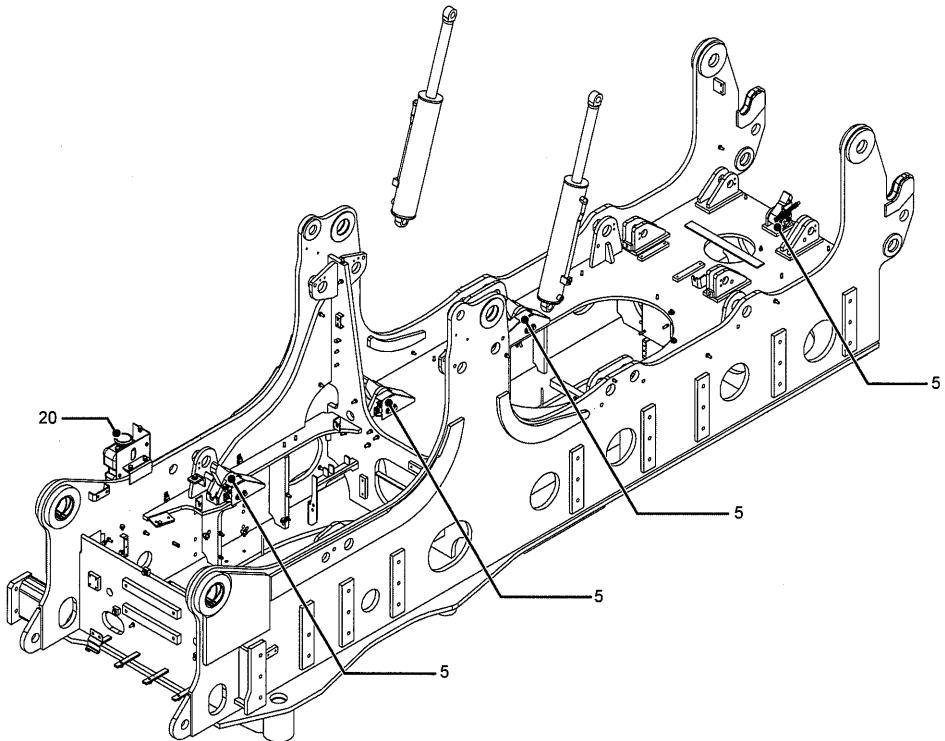

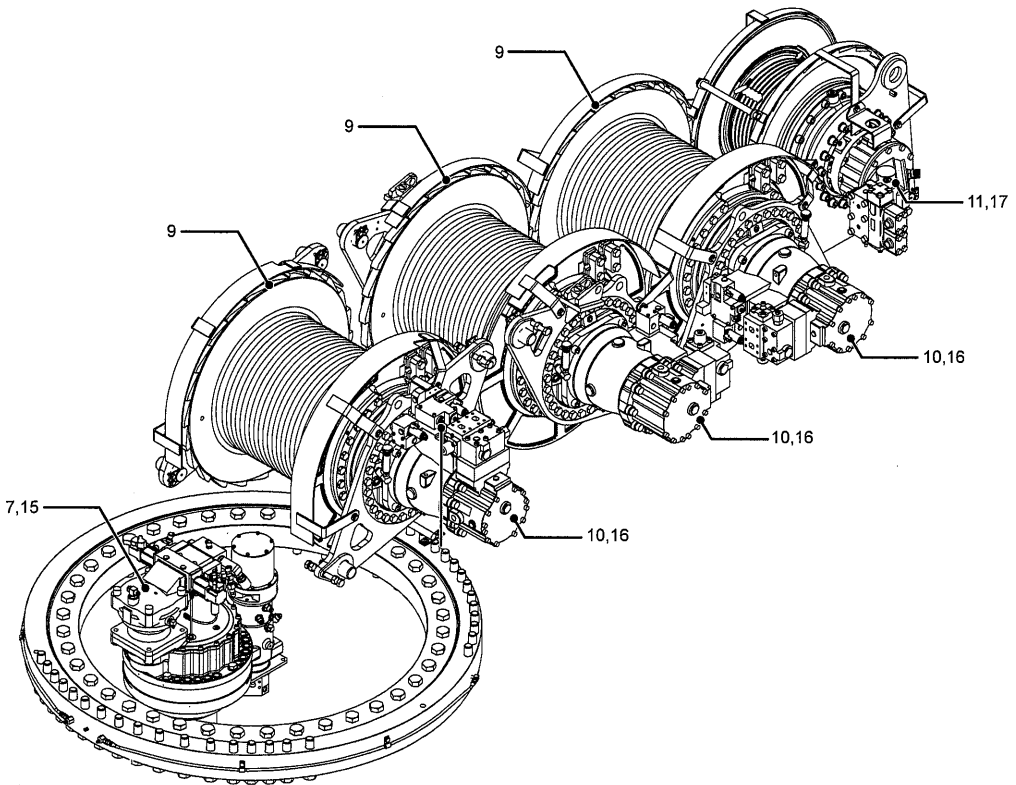
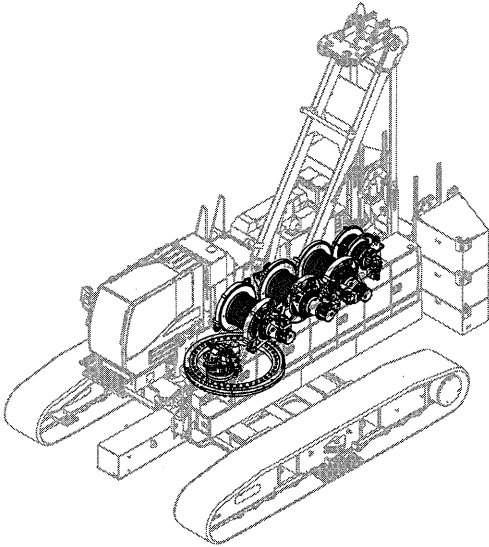

UPPER LUBRICATION TABLE (WATER SUPPLY)

Check and lubrication interval	Check and lubrication place	Required service	Kind of lubricant	Amount : L (gal)	Reference page
Daily or every 8 hours (Every shift)	1. FUEL TANK *1	Supply fuel	Diesel fuel	400 (105.6)	P.7-62
	2. ENGINE (ENGINE OIL)	Check oil level	MO	—	P.7-63
	3. RADIATOR	Check coolant level	Soft water	—	P.7-64
	4. HYD. OIL TANK	Check oil level	HO	—	P.7-65
Weekly or every 50 hours	5. DRUM LOCK (FRONT, REAR, THIRD, BOOM)	Grease	EPG	—	P.7-66
	6. HYD. OIL TANK	Drain	—	—	P.7-66
Monthly or every 100 hours	7. SWING REDUCTION UNIT	Check oil level	GO	—	P.7-67
	8. POWER DIVIDER	Check oil level	GO	—	P.7-67
Quarterly or every 250 hours	9. DRUM SHAFT BEARING	Grease	EPG	—	P.7-68
	10. REDUCTION UNIT (FRONT, REAR, THIRD DRUM [OPTION])	Check oil level	GO	—	P.7-68
	11. REDUCTION UNIT (BOOM DRUM)	Check oil level	GO	—	P.7-68
	12. ENGINE *2	Replace oil	MO	28.5 (7.5)	P.7-69
Half years or 500 hours	13. FUEL TANK	Drain	—	—	P.7-69
Annually or every 1,000 hours	14. RADIATOR *3	Replace coolant	Soft water	34 (9.0)	P.7-70
	15. REDUCTION UNIT (SWING)	Replace oil	GO	16.5 (4.4)	P.7-71
	16. REDUCTION UNIT (FRONT, REAR, THIRD DRUM [OPTION])	Replace oil	GO	22/1 pc (5.8/1 pc)	P.7-72
	17. REDUCTION UNIT (BOOM DRUM)	Replace oil	GO	8 (2.1)	P.7-72
Every 2 years or 2,000 hours	18. POWER DIVIDER	Replace oil	GO	10 (2.6)	P.7-73
	19. HYDRAULIC OIL TANK	Replace oil	HO	460 (121.5)	P.7-74
	20. WASHER TANK	Supply liquid	Washer liquid	—	—

*1 Replace item 1 whenever required.

*2 Replace item 12 at the initial 50 hours.

*3 Item 14, this is when the long life coolant is used.
On the other case, replace item 14 on every 6 months.

Clean the grease fittings before greasing.

Wipe off the excess grease.



Stop the engine when supplying grease.

7.3.2 LOWER LUBRICATION

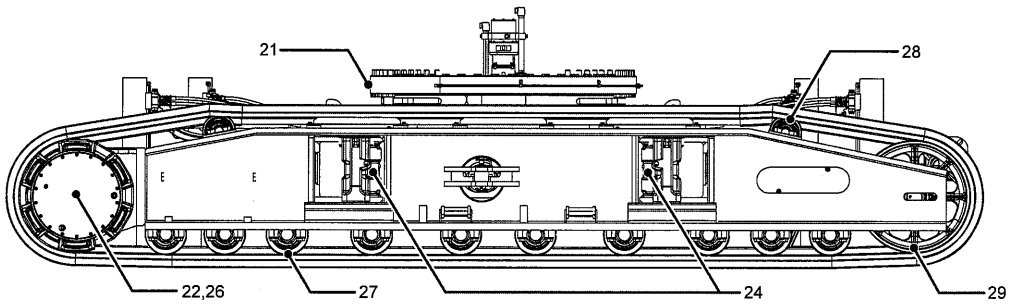
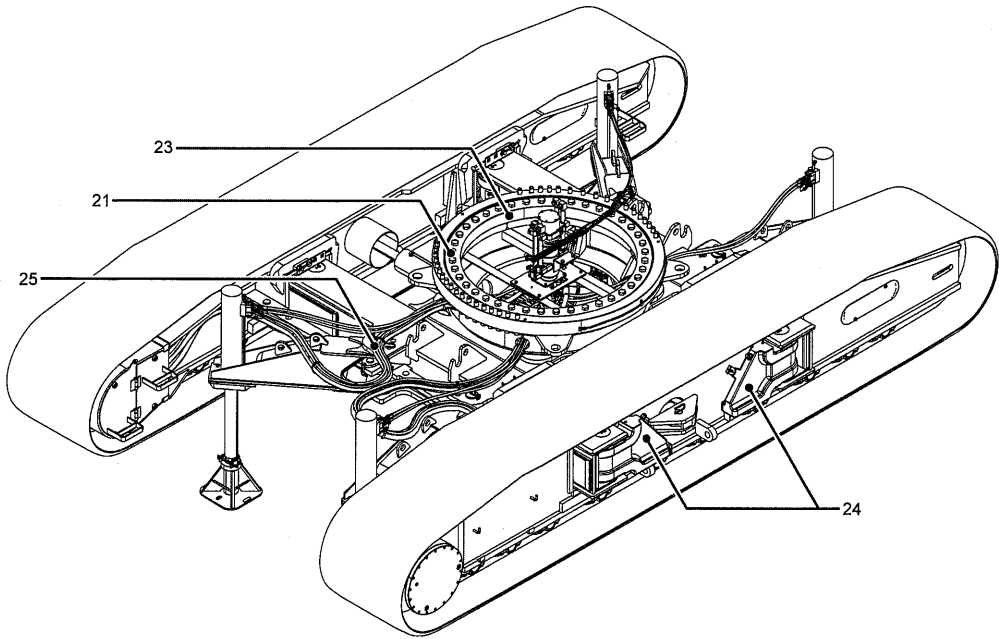

LOWER LUBRICATION TABLE (WATER SUPPLY)

Check and lubrication interval	Check and lubrication place	Required service	Kind of lubricant	Amount : L (gal)	Reference page
Weekly or every 50 hours	21. SLEWING BEARING	Grease	EPG	—	P.7-75
Quarterly or every 250 hours	22. REDUCTION UNIT (PROPEL)	Check oil level	GO	—	P.7-75
	23. SLEWING RING GEAR *4	Grease	GL	—	P.7-76
	24. AXLE EXTENSION	Grease	EPG	—	P.7-76
	25. TRANSLIFTER ARM MTG. PIN	Grease	EPG	—	P.7-77
Annually or every 1,000 hours	26. REDUCTION UNIT (PROPEL)	Change oil	GO	25/pc (6.6/pc)	P.7-77
*5	27. LOWER ROLLER	Change oil	GO	0.13/pc (0.03/pc)	P.7-78
	28. UPPER ROLLER	Change oil	GO	0.06/pc (0.02/pc)	P.7-78
	29. IDLER WHEEL	Change oil	GO	0.25/pc (0.06/pc)	P.7-78

*4 Apply grease item 23 on every week or every 50 hours operation in case of clamshell or lifting magnet work.

*5 Item 27 to 29, change oil at the overhaul time if there is no abnormality such as oil leak is noted.

Clean the grease fittings before greasing.

Wipe off the excess grease.



Stop the engine when supplying grease.

7.3.3 ATTACHMENT LUBRICATION

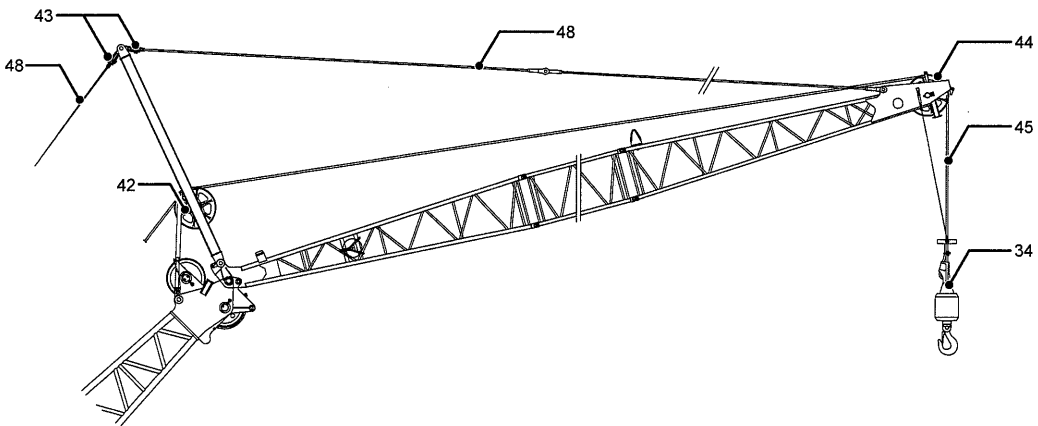
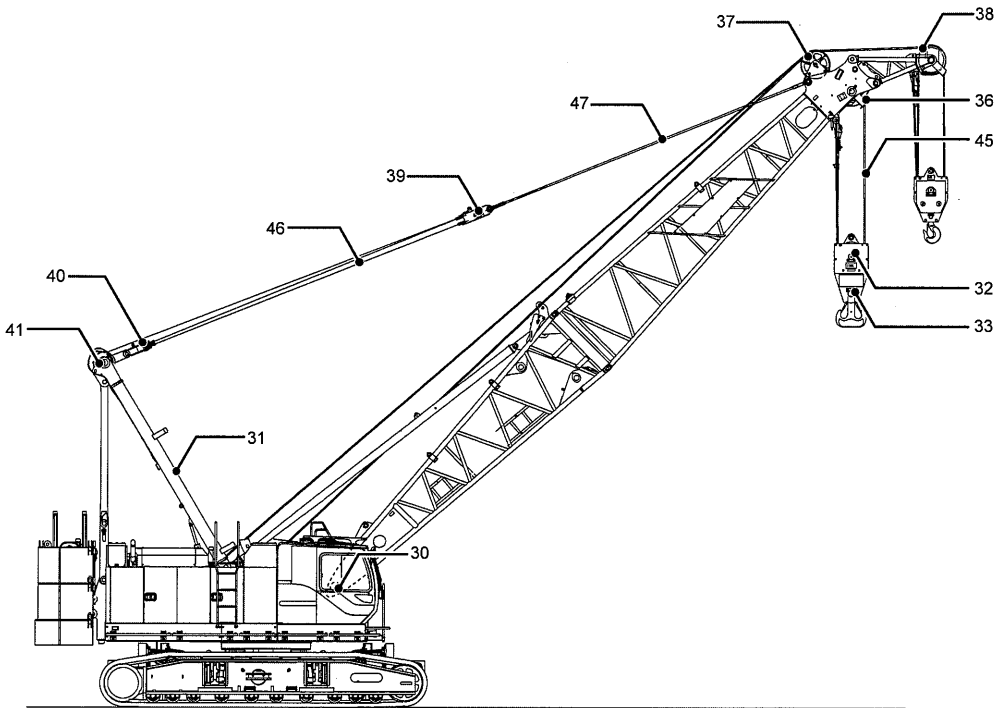

ATTACHMENT LUBRICATION TABLE

Check and lubrication interval	Check and lubrication place	Required service	Kind of lubricant	Reference page
Daily or every 8 hours (Every shift)	30. BOOM FOOT PIN	Grease	EPG	P.7-79
	31. GANTRY LINK	Grease	EPG	P.7-79
Weekly or every 50 hours	32. HOOK SHEAVE	Grease	EPG	P.7-80
	33. HOOK BEARING	Grease	EPG	P.7-80
	34. BALL HOOK BEARING	Grease	EPG	P.7-80
Annually or every 1,000 hours *6	36. BOOM POINT SHEAVE	Grease	EPG	—
	37. IDLER SHEAVE	Grease	EPG	—
	38. AUXILIARY SHEAVE	Grease	EPG	—
	39. UPPER SPREADER SHEAVE (BOOM HOIST)	Grease	EPG	—
	40. LOWER SPREADER SHEAVE (BOOM HOIST)	Grease	EPG	—
	41. GANTRY PEAK SHEAVE	Grease	EPG	—
	42. STRUT SHEAVE	Grease	EPG	—
	43. STRUT EQUALIZER SHEAVE	Grease	EPG	—
*7	44. JIB POINT SHEAVE	Grease	EPG	—
	45. FRONT, REAR DRUM HOIST WIRE ROPE	Lubricate	WO	—
	46. BOOM DRUM HOIST WIRE ROPE	Lubricate	WO	—
	47. BOOM GUY LINE	Lubricate	WO	—
	48. JIB GUY LINE	Lubricate	WO	—

*6 Item 36 to 44 are grease sealed type.

If plug is installed to sheave pin or sheave, change it with grease fitting.

In case of clamshell, lifting magnet or hammer grab, grease to item 36 to 41 on every 500 hours.

*7 Apply lubricant to the wire rope based on work condition.

Use brush or spray when applying lubricant to wire rope.

Clean the grease fittings before greasing.

Wipe off the excess grease.



Stop the engine when supplying grease.

7.3.4 INSPECTION, GREASING (WATER SUPPLY) ON EACH POINT

INSPECTION, GREASING (WATER SUPPLY) ON UPPER MACHINERY

(Refer to P.7-50)

1. REFILLING FUEL

After daily work is finished, fill the fuel tank as full as possible in order to minimize condensation.

CAUTION

Never run the fuel pump empty.

WARNING

Do not use fuel other than those specified.
Check for proper type of fuel again before refilling.
When fuel is to be refilled, ensure to stop the engine.

Do not overfill the fuel.

Otherwise it may cause fire.

Ensure to wipe off spilled fuel completely.

Do not bring fire close.

Failure to observe these precautions may result in serious injuries or loss of life.

WARNING

Use ultra low sulfur diesel fuel only (S50 : sulfur content lower than 50 ppm).

If fuel other than specified one is used, adverse affect may be caused to the engine or diesel particulate filter and white smoke or failure may be resulted.

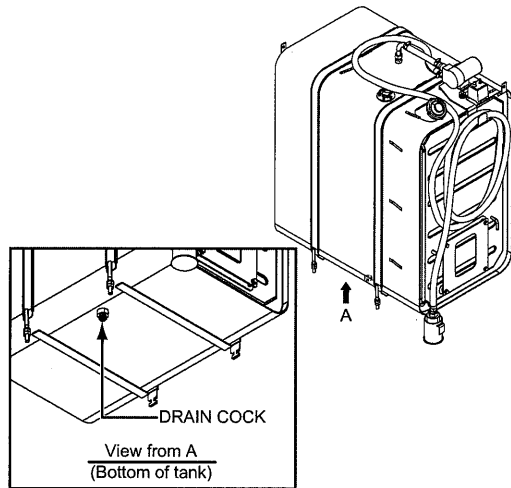

The fuel pump is optional item.
 If the fuel pump is not equipped, supply fuel
 from the filler port.

Refer to P.7-69 for fuel tank drain.

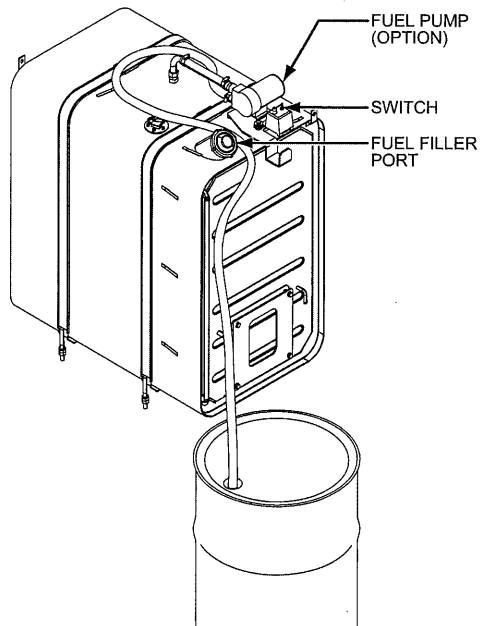

7

2. ENGINE OIL LEVEL CHECK

Ensure to check the engine oil level prior to
 work.

Wipe the level gauge clean once and then insert
 the level gauge.

If the level is within the range of proper oil level,
 it is normal.

Refer to P.7-69 for replacing engine oil.

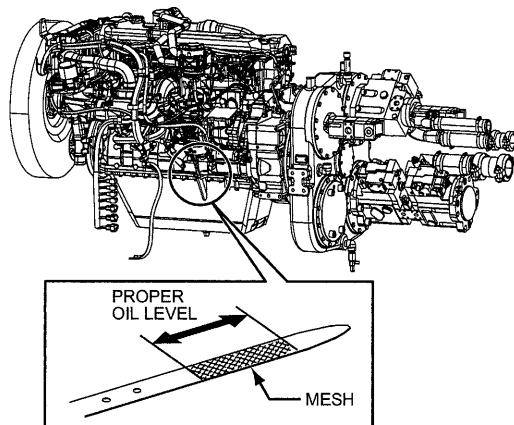

3. CHECKING OF COOLANT LEVEL

⚠ WARNING

Do not remove the radiator cap while the engine is hot.

Use a heavy cloth or gloves to protect yourself while slowly loosening the cap.

Wait until any sound or fluid flow stops before removing cap.

Engine coolant is hot and under pressure when the engine is at operating temperature.

Failure to observe this precaution may result in a serious injury or loss of life.

After removing the radiator cap, confirm the coolant level, and also confirm the coolant level of the sub-tank.

- When coolant is insufficient, fill the radiator up to the foot of the water supply port. Fill the sub-tank up to the "FULL" mark position with soft water.

Refer to P.7-70 for replacing coolant.

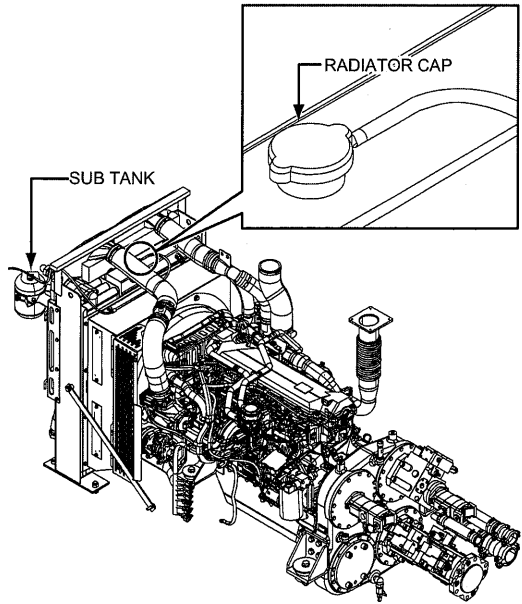

4. CHECK OF HYDRAULIC OIL LEVEL

If the hydraulic oil level is within the specified range shown in the label of the level gauge with the following conditions and the engine running, the oil level is normal.

(Oil temperature : 20°C [68°F])

Gantry cylinder : Extended

Crawler ext/retr cylinder : Extended

Translifter cylinder : Retracted

CWT self removal cylinder : Retracted

Refer to P.7-74 for replacing hydraulic oil.

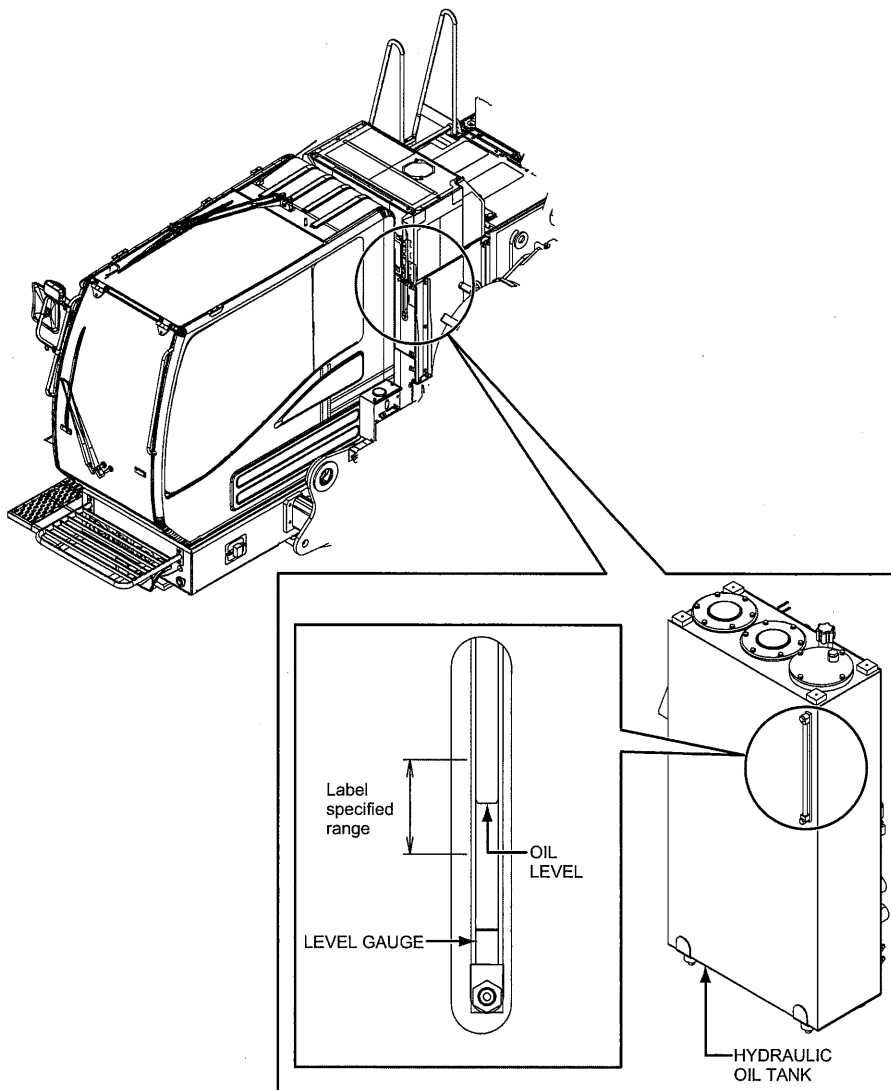

5. DRUM LOCK

Supply grease to the drum lock of the front, rear and third drum (option) from the grease fittings provided on the front face of the swing frame. (2 or 3 for with third drum)

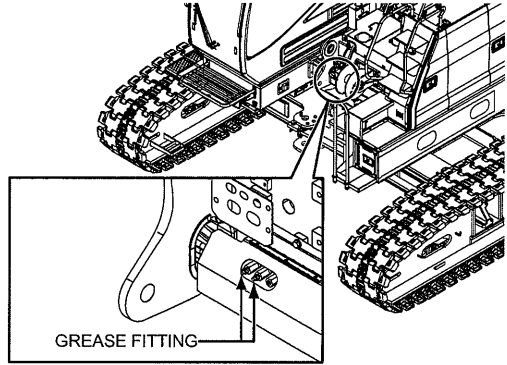

Supply grease to the boom drum lock from the grease fitting provided under the swing frame.

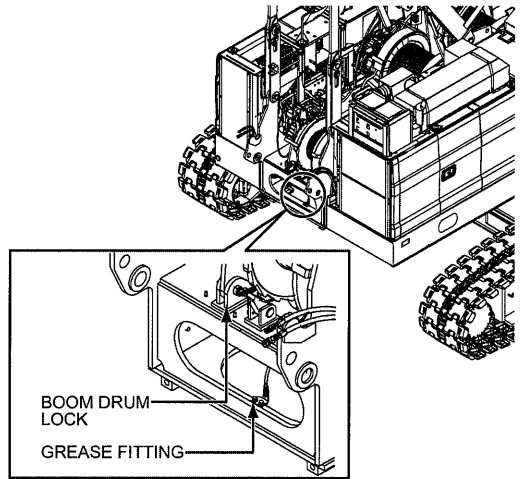

6. DRAIN OF HYDRAULIC OIL TANK

Before starting operation, loosen the drain plug to drain water and sediment from the tank. (2 locations)

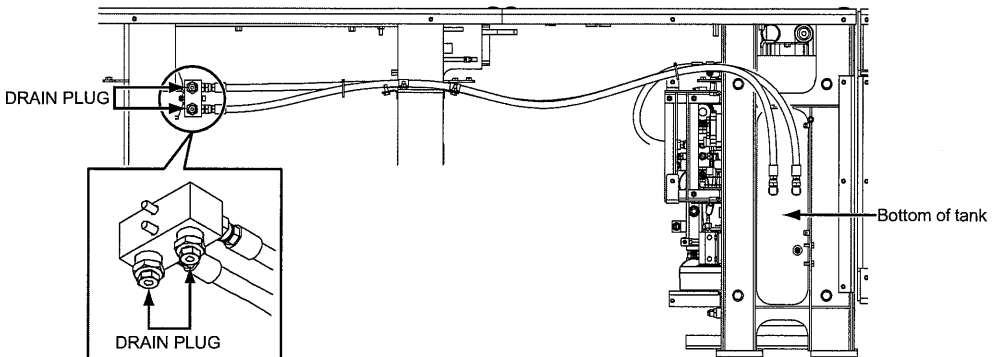

View from under the deck

7. OIL LEVEL CHECK OF SWING REDUCTION UNIT

Check the oil level more than 30 minutes after the operation is stopped.

If the oil level is in the proper oil level, it is normal.

Refer to P.7-71 for oil change of the swing reduction unit.

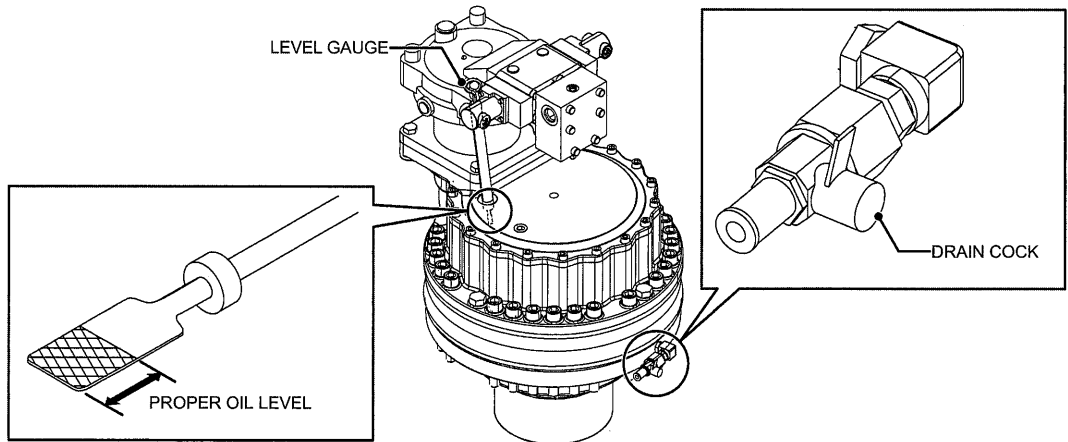

8. OIL LEVEL CHECK OF POWER DIVIDER

Check the oil level more than 30 minutes after the operation is stopped.

If the oil level is up to the red color mark of the level gauge, it is normal.

Refer to P.7-73 for oil change of the power divider.

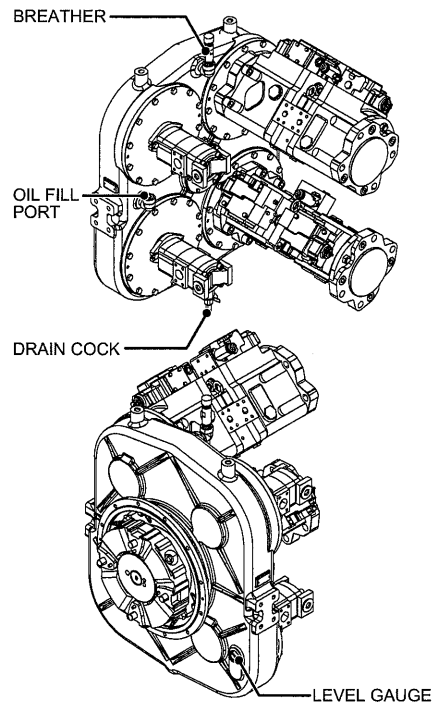

9. DRUM SHAFT BEARING

Supply grease from the grease fitting provided on the bearing sleeve on the rope clamp side. There are 3 grease fittings but take one easiest grease point. (It is not necessary to grease from all 3 points.)

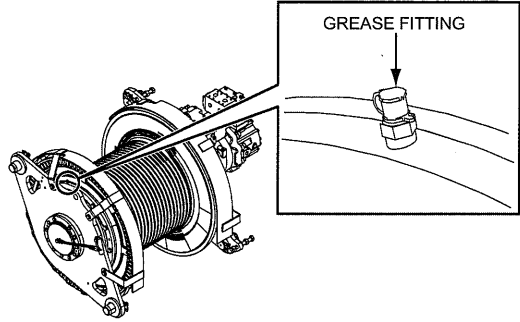

10. OIL LEVEL CHECK OF REDUCTION UNIT (FRONT, REAR, THIRD DRUM [OPTION])

More than 30 minutes of operation stop, check the oil level.

If the oil level is up to red mark on the oil level meter, it is normal in case of front drum and rear drum.

Refer to P.7-72 for oil change of reduction unit (front, rear and third drum [option]).

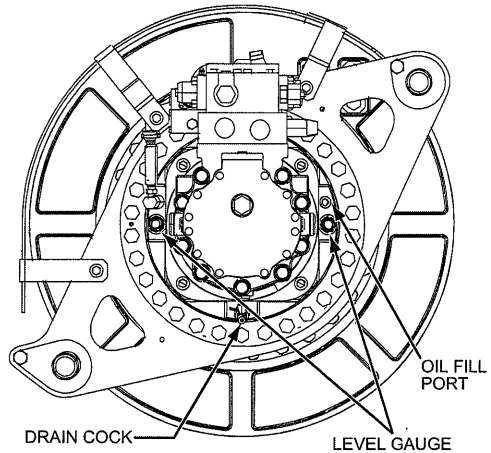

11. OIL LEVEL CHECK OF WINCH REDUCTION UNIT (BOOM DRUM)

More than 30 minutes of operation stop, check the oil level.

If the level is up to the specified point, it is normal.

Refer to P.7-72 for oil change of the winch reduction unit (boom drum).

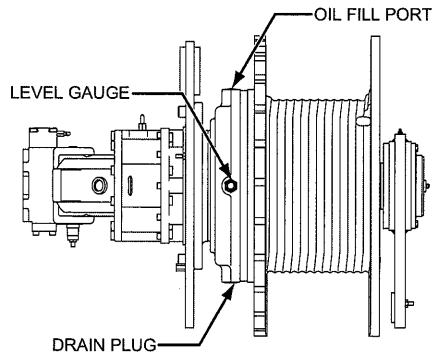

View from rear side of the reduction unit (boom drum)

12. ENGINE OIL CHANGE

⚠ WARNING

Draining the engine oil while it is hot may cause burns.

Drain the oil after it becomes cool.

Failure to observe this precaution may result in serious injuries or loss of life.

⚠ CAUTION

The warranty does not cover malfunctions caused by the use of parts other than KOBELCO genuine parts (genuine oil, grease and filter).

- (1) Prepare the container about 30 L (7.9 gal).
- (2) Loosen the drain plug and drain the oil to the prepared container.
- (3) Tighten the drain plug.
- (4) Check the drained oil for no metal powder mixed and pour the new oil to the fill port. When changing oil, replace the oil filter.
- (5) When the filter element and the total quantity of the oil are changed, pour the oil using the guidepost position of oil pouring. (Do not start the engine.) Drive the engine for a few minutes. Stop the engine for about 30 minutes. Then confirm that the oil level is in the proper level.

13. FUEL TANK DRAIN

Loosen the drain plug and drain the water or sediment in the tank.

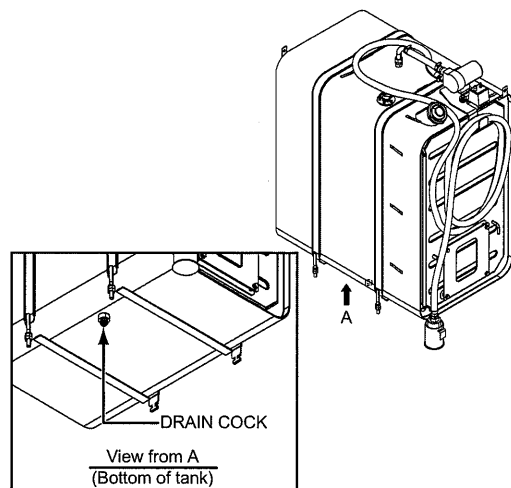
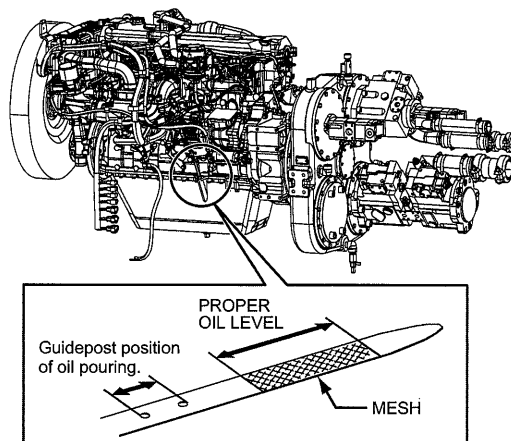
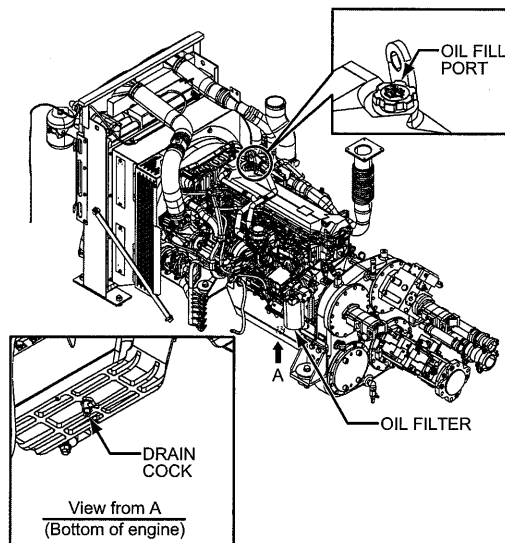

14. CHANGE OF COOLANT

⚠ WARNING

Do not drain the coolant when it is hot.
The hot water may spout out which could result in a personal injury.
After the water has cooled, drain the water.
Failure to observe this precaution may result in a serious injury.

- (1) Loosen the drain cock in the bottom of the radiator and the plug of the water jacket, drain the coolant.
- (2) Combine soft water (tap water) and long life coolant, and fill the radiator up to the foot of the water supply port.
 In order to prevent air from entering, slowly pour coolant.
 After coolant pouring, confirm that the coolant level does not lower, then tighten the radiator cap.
- (3) Start and run the engine for about 1 minute.
 Stop the engine, and check coolant level.
 If insufficient, add coolant.

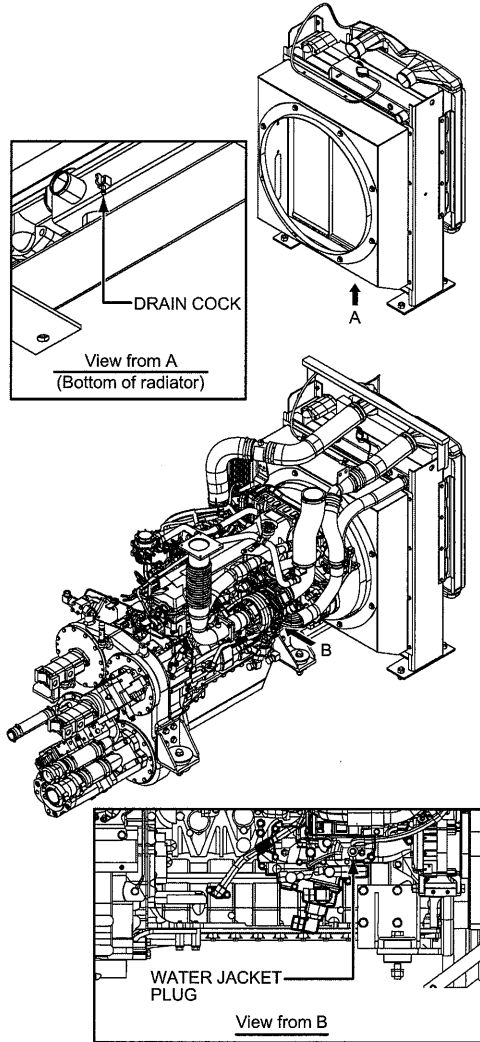

COOLANT BLENDING

Blend the coolant (long life coolant) based on ambient temperature.
 Refer to P.7-109 for blending.

15. OIL CHANGE OF SWING REDUCTION UNIT

With the gauge stick drawn out, loosen the drain cock, and drain the oil into a prepared container. Shut the drain cock and supply the specified oil through the fill port until the oil level reaches the specified level.

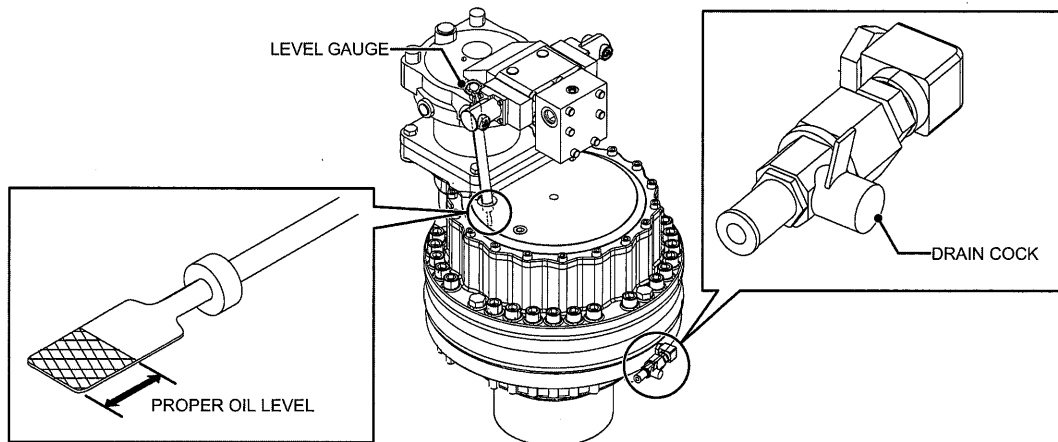

7

⚠ WARNING

Do not drain the oil when it is hot.
The hot oil may spout out which could result in a personal injury.
After the oil has cooled, drain the oil.
Failure to observe this precaution may result in a serious injury.

**16. OIL CHANGE OF REDUCTION UNIT
(FRONT, REAR, THIRD DRUM [OPTION])**

Prepare a container of approx. 30 L (7.9 gal) capacity.

With the oil fill plug removed, turn the lever of the drain cock to drain the oil into the prepared container.

Return the lever of the drain cock to the original position, and supply the specified oil through the oil fill port until the oil level reaches the specified oil level.

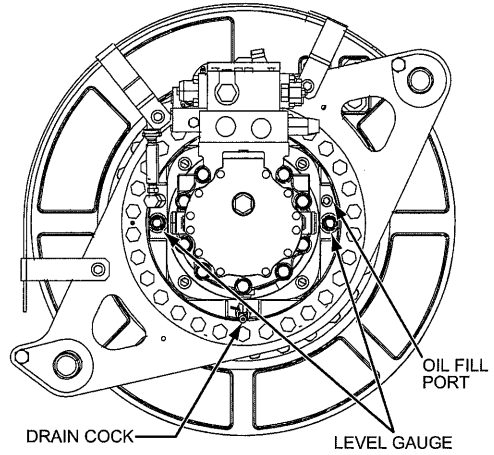

⚠ WARNING

Do not drain the oil when it is hot.
The hot oil may spout out which could result in a personal injury.
After the oil has cooled, drain the oil.
Failure to observe this precaution may result in a serious injury.

**17. OIL CHANGE OF BOOM HOIST DRUM
REDUCTION UNIT**

Prepare a container of approx. 10 L (2.6 gal) of capacity.

With the level plug removed, remove the drain plug to drain the oil into the container.

Return the drain plug to the original position, and supply the specified oil through the oil fill port until the oil level reaches the specified level.

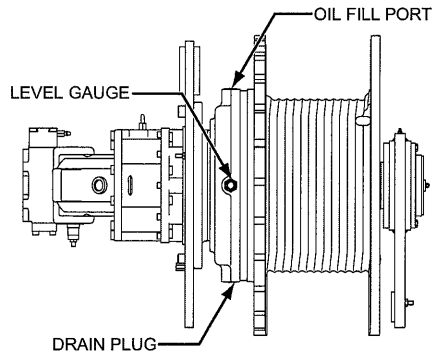

View from rear side of the reduction unit (boom drum)

18. OIL CHANGE OF POWER DIVIDER

Prepare a container of approx. 20 L (5.3 gal) of capacity.

With the cap of the oil supply port removed, turn the lever of the drain cock to drain the oil into the container.

Return the lever of the drain cock to the original position, pour the specified oil through the oil supply port until the oil level reaches the specified level.

WARNING

Do not drain the oil when it is hot.

The hot oil may spout out which could result in a personal injury.

After the oil has cooled, drain the oil.

Failure to observe this precaution may result in a serious injury or loss of life.

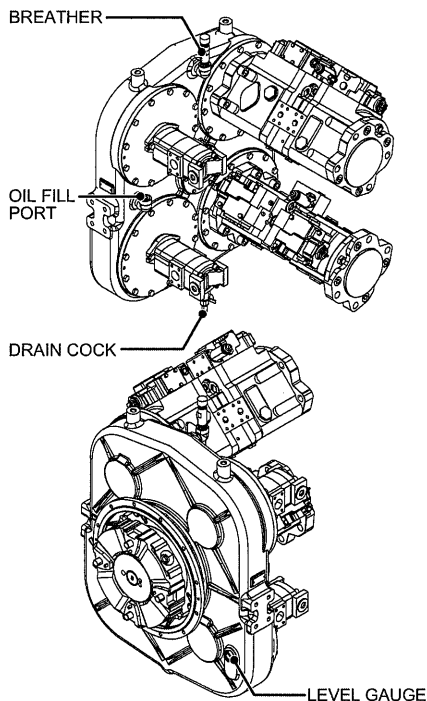

19. CHANGE OF HYDRAULIC OIL

WARNING

Do not drain the oil when it is hot.

The hot oil may spout out which could result in a personal injury.

After the oil has cooled, drain the oil.

Failure to observe this precaution may result in a serious injury or loss of life.

CAUTION

Extra care must be taken to ensure that all the hydraulic tank is completely filled with oil before the engine is restarted.

Failure to properly prime the hydraulic pumps could result in a catastrophic failure of the pumps.

It is standard to replace hydraulic oil every 2,000 hours of the hourmeter, but if the oil is remarkably contaminated or deteriorated, replace the oil regardless of operating hours.

- (1) Prepare a container of approx. 400 L (105.6 gal).
- (2) Remove the cap of the filler port and filter cover.
- (3) Loosen the drain plug and drain the hydraulic oil into the prepared container.
- (4) Replace the drain plug, fill the tank with the specified hydraulic oil through the filler port up to the specified level.
- (5) Reinstall the filter cover and oil supply cap.
- (6) Check the oil level again.

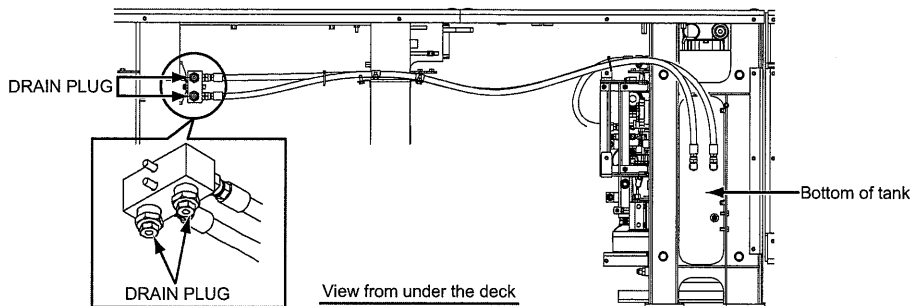

When changing hydraulic oil, change the filter also at the same time.

INSPECTION, GREASING OF LOWER MACHINERY

(Refer to P.7-58)

21. SLEWING BEARING

Grease through the grease fitting provided on the slewing ring bearing.

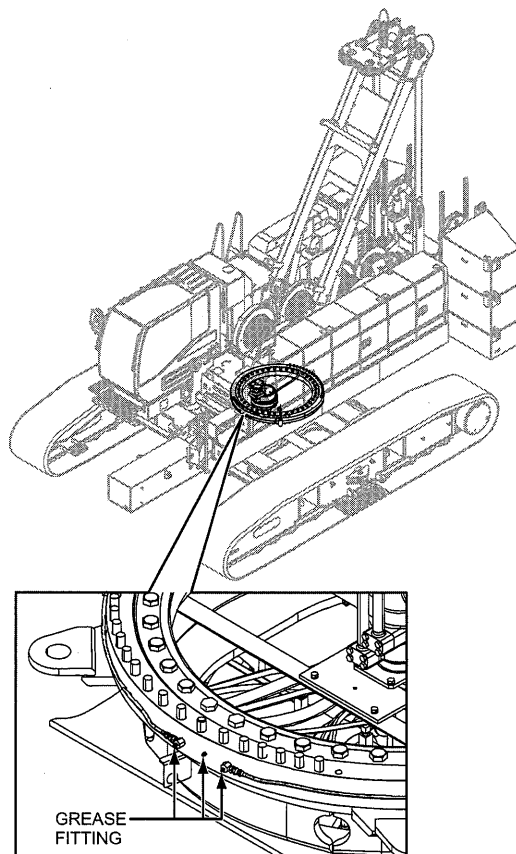

7

22. OIL LEVEL CHECK OF PROPEL REDUCTION UNIT

Check the oil level more than 30 minutes after the operation is stopped.

With the drain plug positioned at the lower side, remove the level plug.

If the oil level is up to the bottom of the level plug opening, it is normal.

Refer to P.7-77 for oil change of the propel reduction unit.

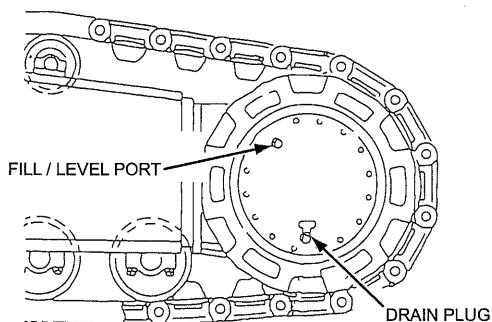

23. SLEWING RING GEAR

Removing the upper and lower cover in the swing frame front, turn the upper little by little, and grease so that grease goes around the entire ring gear.

⚠ WARNING

To avoid injury, do not apply grease to slewing ring gear directly by hand.

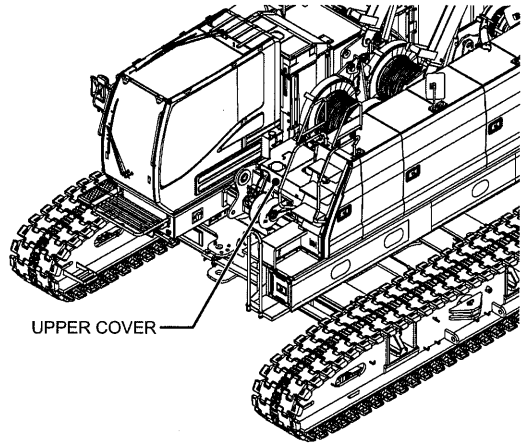
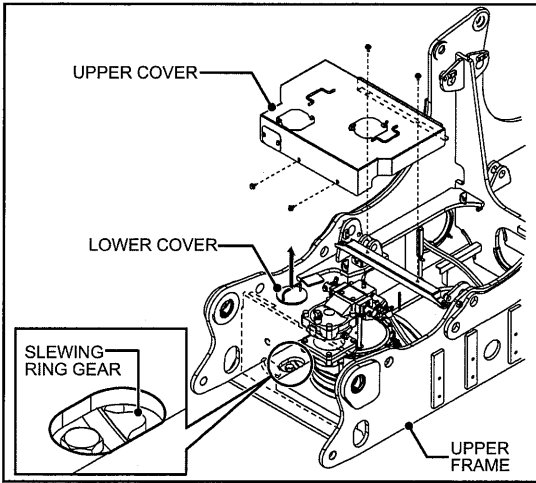

24. AXLE EXTENSION

Apply grease from the grease fitting provided in the rotating area of the axle extension. Grease from the inside with the crawler extended. (4 locations)

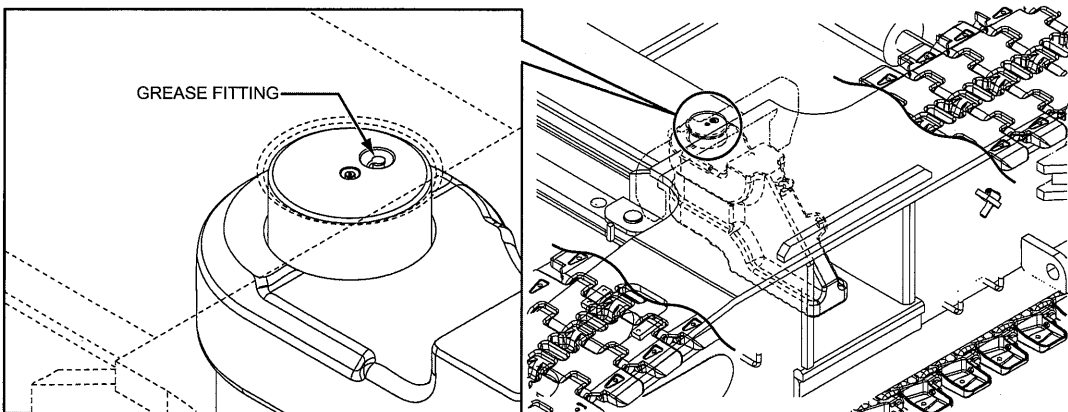

25. TRANSLIFTER ARM MOUNTING PIN

Supply grease from the grease fitting provided on the rotating area of the translifter arm.
(4 locations on upper side, 4 locations on lower side, total 8 locations)

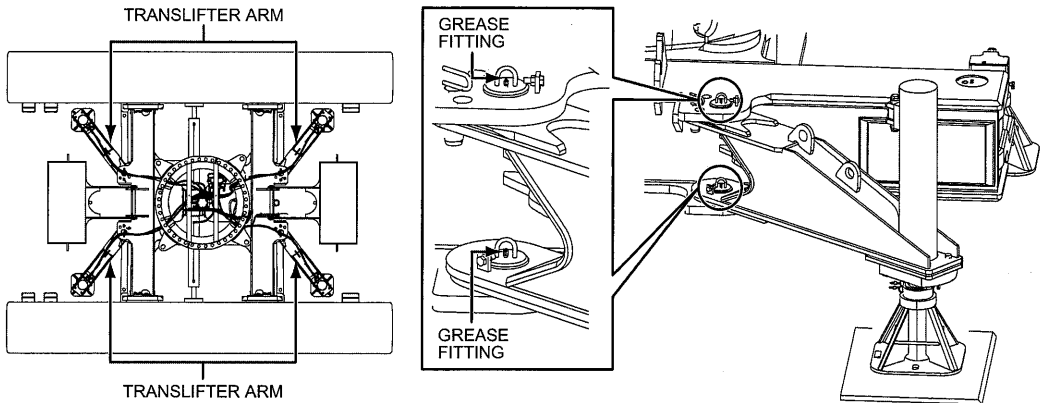
**26. OIL CHANGE OF PROPEL REDUCTION UNIT**

Prepare a container of approx. 30 L (7.9 gal) of capacity.

With the level plug removed, remove the drain plug to drain the oil into the container.

Reinstall the drain plug, pour the specified oil through the fill/level port until the oil reaches the specified level.

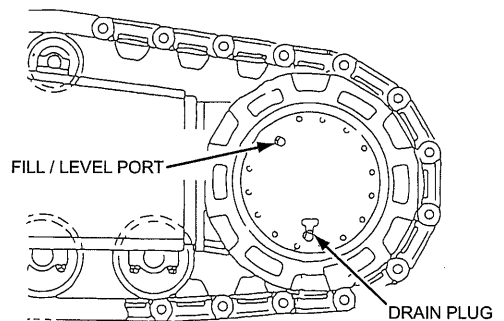
**WARNING**

Do not drain the oil when it is hot.

The hot oil may spout out which could result in a personal injury.

After the oil has cooled, drain the oil.

Failure to observe this precaution may result in a serious injury or loss of life.

27. OIL CHANGE OF LOWER ROLLER

Remove the both end plugs to drain the oil.
Supply the specified oil of specified amount.
To change oil, consult the local KOBELCO
authorized distributor.

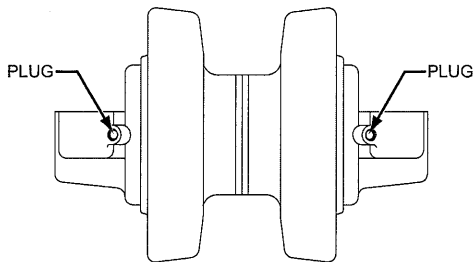

28. OIL CHANGE OF UPPER ROLLER

Remove the both end plugs to drain the oil.
Supply the specified oil of specified amount.
To change oil, consult the local KOBELCO
authorized distributor.

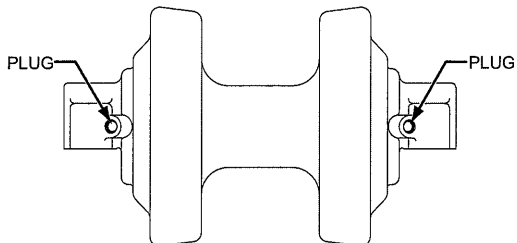

29. OIL CHANGE OF IDLER WHEEL

Remove the plug of the sliding block to drain
the oil.
Supply the specified oil of specified amount.
To change oil, consult the local KOBELCO
authorized distributor.

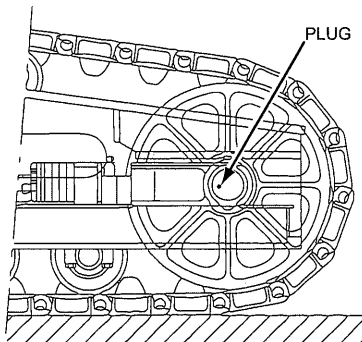

INSPECTION, LUBRICATION OF ATTACHMENT

(Refer to P.7-60)

30. BOOM FOOT PIN

Grease through the grease fitting on the foot pin. (Left and right)

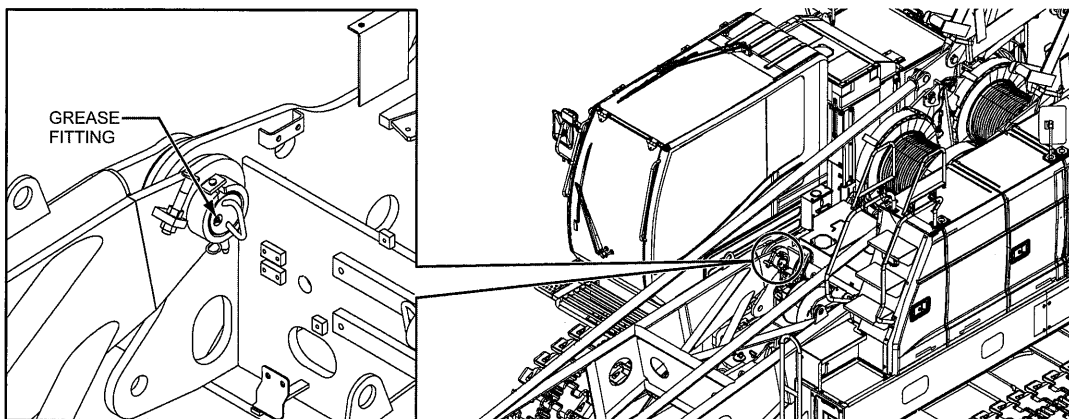

31. GANTRY LINK

Grease through the grease fitting provided on the front member.

CAUTION

Before climbing on machine make certain that the guard and walk ways are clean and dry, and use safety belt in order to prevent falls due to slippery surface.

Failure to observe this precaution may result in a serious injury or loss of life.

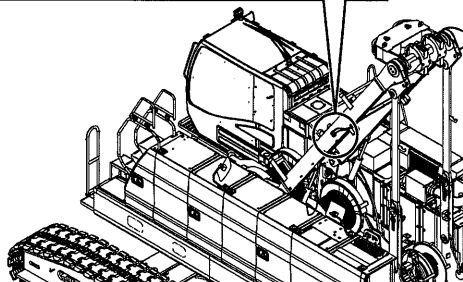
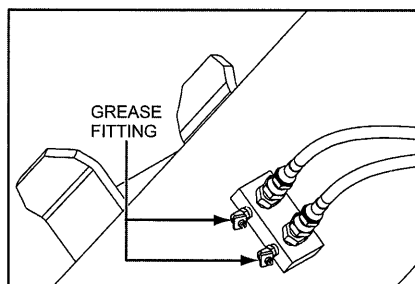

32. HOOK SHEAVE

Grease from the grease fitting on the sheave pin.

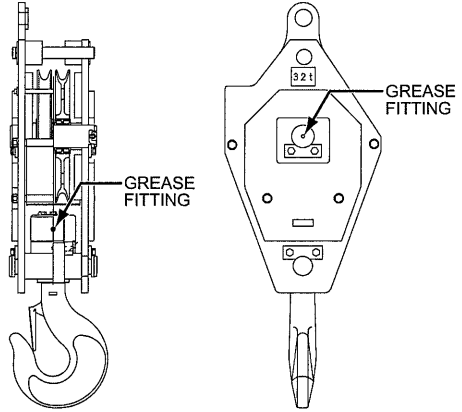

33. HOOK BEARING

Grease from the grease fitting on the bearing cap.

34. BALL HOOK BEARING

Grease from the grease fitting provided on the bearing cap.

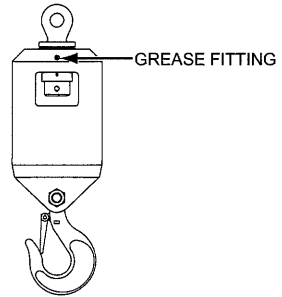

This page is blank for editing convenience.

7.4 CLEANING/WASHING/CHANGING FILTER ELEMENT AND STRAINER

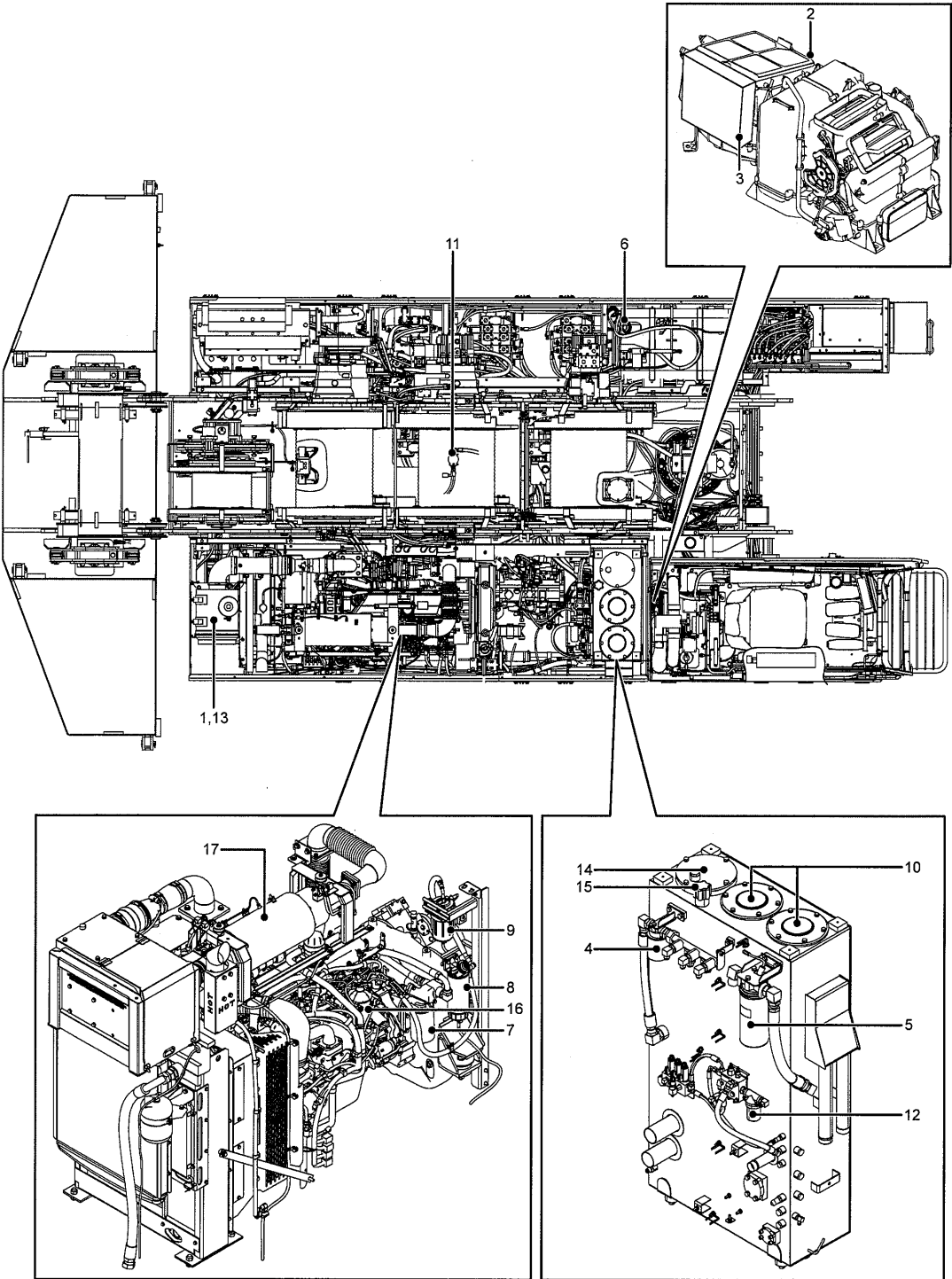

Check interval	Check, lubrication, change point clean	Required service	Part No.	Quantity	Reference page
Monthly or every 100 hours	1. CLEANING AIR ELEMENT	Clean	NIPPON-DONALDSON (P812362)	1	P.7-84
	2. CLEANING AIR CONDITIONER FILTER (INTERNAL AIR FILTER)	Clean	YT20M00004S050 SANDEN	1	P.7-84
	3. CLEANING AIR CONDITIONER FILTER (OPEN AIR FILTER)	Clean	YN50V01006P1 SANDEN (51186-41870)	1	P.7-84
Quarterly or every 250 hours	4. CHANGING DRAIN FILTER (CARTRIDGE)	Replace	2446U141S2	1	P.7-86
	5. CHANGE OF LINE FILTER FOR BRAKE COOLING LINE (CARTRIDGE)	Replace	2446U254S3	1	P.7-87
	6. WASHING FUEL TANK FILL PORT STRAINER	Wash		1	P.7-87
	7. CHANGE OF ENGINE OIL ELEMENT	Replace	HINO MOTORS (VHS1560-72190)	1	P.7-88
Half years or 500 hours	8. REPLACING FUEL FILTER	Replace	HINO MOTORS (VH23414-E0020)	1	P.7-89
	9. CHANGING OF FUEL PRE-FILTER	Replace	YN21P01068R100 (Element, O-ring, gasket)	1	P.7-92
Annually or every 1,000 hours	10. CHANGE OF HYDRAULIC OIL TANK RETURN FILTERS	Replace	YN52V01016R110 (Repair kit)	2	P.7-93
	11. WASHING OF LINE FILTER (a)	Wash, Replace	2446R183S2 (Filter) 45Z91D84 (O-ring)	1	P.7-96
	12. WASHING OF LINE FILTER (b)	Wash, Replace	R36P0019 (Filter) 2446U346S5 (O-ring)	1	P.7-96
	13. CHANGING OF AIR ELEMENT	Replace	NIPPON-DONALDSON (P812362)	1	P.7-96
Every 2 years or 2,000 hours	14. CHANGING HYDRAULIC OIL SUCTION FILTER	Replace	GN50V00001S001 (Element)	1	P.7-97
	15. WASHING FILL PORT STRAINER	Wash		1	P.7-97
	16. REPLACING FUEL FILTER (ON ENGINE)	Replace		1	P.7-98
Every 4,500 hours	17. CLEANING OR REPLACING DIESEL PARTICULATE FILTER	Clean, Replace	HINO MOTORS (VHS1850-E0750)	1	P.7-100

* Replace item 4, 5, 7 at the initial 50 hours.

1. CLEANING AIR ELEMENT

Remove the air element, and blow air from the inside to remove any dust.

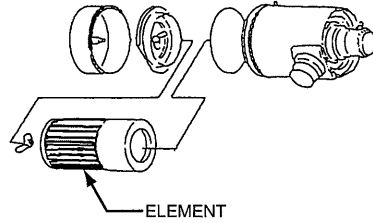

2. CLEANING AIR CONDITIONER FILTER (INTERNAL AIR FILTER)

3. CLEANING AIR CONDITIONER FILTER (OPEN AIR FILTER)

The clogged air conditioner filter causes air volume to decrease and low air conditioner performance.

Clean the filter according to the check and maintenance list.

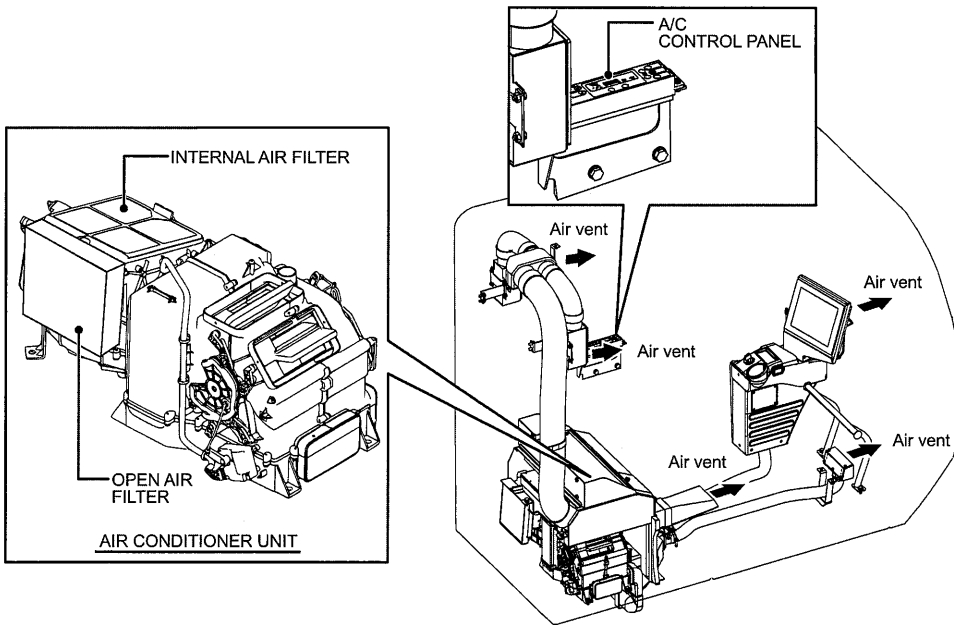

Removal and installation

(1) Internal air filter

Removal :

Remove the emergency cable cover.

Then, pick the tab of the filter, and remove the filter upward.

Installation :

Install the filter by reversing the removal steps.

(2) Open air filter

Removal :

Remove the cover on the rear of the seat and take out the filter upward.

Installation :

Take the reverse way of the installation.

Cleaning

(1) Cleaning of the internal air filter (once a month)

- Remove the inspection window in rear of the operator's seat.
- Draw out the filter upward.
- Remove any dirt including dusts from the filter with compressed air.

If the filter is excessively dirty or clogged, immerse it in lukewarm water with a neutral detergent dissolved, and wash it by moving it up, down, right.

Then, rinse it with clean water, and let it dry completely.

(2) Cleaning of the open air filter (once a month)

- Remove the cover on the back of the operator's seat.
- Draw out the filter.
- Remove any dirt including dusts from the filter with compressed air.

If the filter is excessively dirty or clogged, immerse it in the lukewarm water with a neutral detergent dissolved, and wash it by forcibly moving it back and forth in the solution for twenty to thirty seconds.

Then, rinse it with clean water until detergent bubbles are almost washed away, and shake the filter two or three times to drain water off.

Then, blow compressed air (approx. 5 Pa) right down to the whole surface of the filter for approx. two minutes to dry it completely.

Note

It is recommended that the filters be replaced once a year in order to maintain the filter's good performance.

Carefully handle the filters not to make a hole, nor break them.

4. CHANGING DRAIN FILTER (CARTRIDGE)

Loosen the plug of the filter cover to remove the remaining pressure in the tank.

Prepare an oil container under the filter, and replace the cartridge with a new one.

5. CHANGE OF LINE FILTER FOR BRAKE COOLING LINE (CARTRIDGE)

Loosen the plug of the filter cover to remove the remaining pressure in the tank.
Prepare an oil container under the filter, and replace the cartridge with a new one.

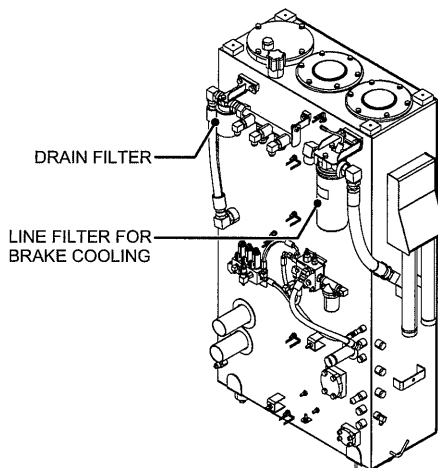

6. WASHING FUEL TANK FILL PORT STRAINER

Remove the cap, take out the strainer and sufficiently wash it with washing liquid.



Keep fuel away from spark or flame.
Failure to observe this precaution may result in a serious accident.

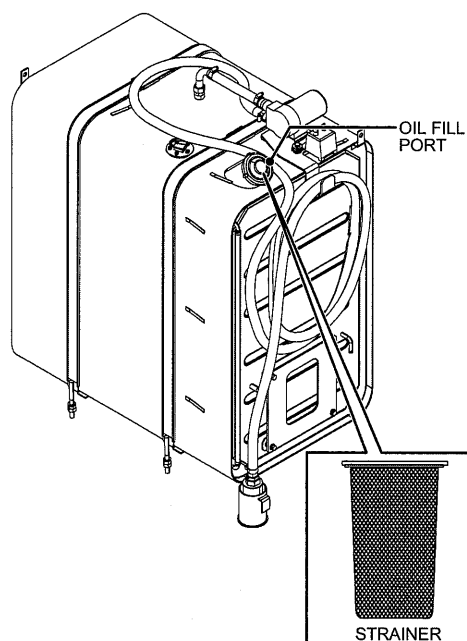

7

7. CHANGE OF ENGINE OIL ELEMENT

- (1) Place the container to receive the oil under the filter.
- (2) Turn the element to left and remove it using the special oil filter wrench.

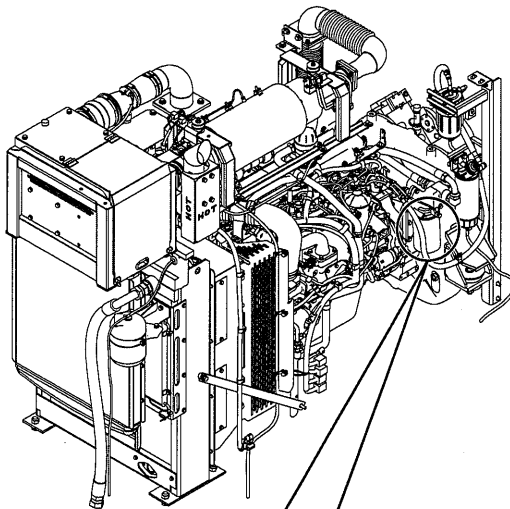

WARNING

Do not remove the engine oil filter while the engine oil is hot.

Oil will be extremely hot and may cause burns.

Failure to observe this precaution may result in serious injuries or loss of life.

- (3) Remove the dirt or mud adhered to the seal face of the oil filter body.
- (4) Apply the engine oil on the gasket of the new element and rotate it lightly to right until it touches the body seal face.

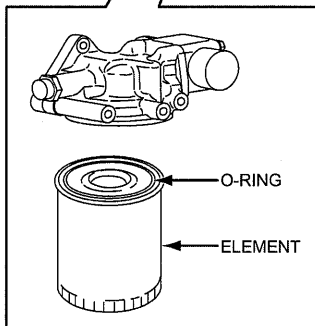

Note

Ensure to use the new gasket supplied as element kit.

When installing it, take extra care not to damage the gasket due to twisting.

Do not reuse the element.

- (5) Under this condition, rotate the element for about 3/4 to 1 turn with the oil filter wrench supplied as special tool.
- (6) After the element is replaced, start the engine and make the element filled with oil and then check the engine oil level.

WARNING

After the element is replaced, start the engine and make sure that this is no oil leak around the filter. Oil leak may result in a fire.

Failure to observe this precaution may result in a serious accident.

8. REPLACING FUEL FILTER

- (1) Removing fuel filter element
- (A) Prepare the container to receive the drained fuel under the drain valve (b).
 - (B) Loosen the drain valve (b) and air bleed plug (a) and drain the fuel accumulated in the fuel filter element.
 - (C) Remove the element (c) from the filter body together with the ball (d).
 - (D) Remove the element (c) from the ball (d).
The ball is to be re-used.
Do not damage it or put flaw on it.

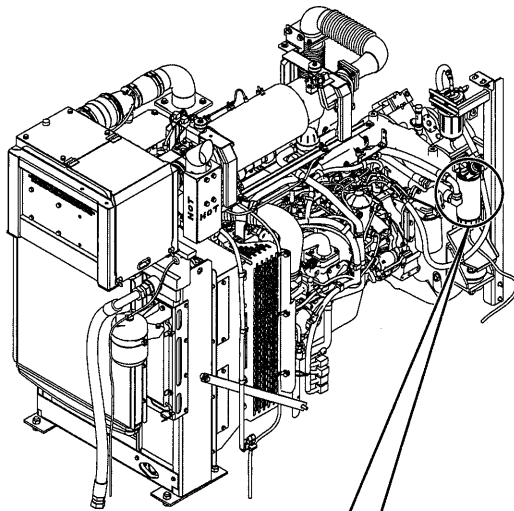

WARNING

The drained water contains the fuel.
Dispose them by following the rule specified by regional authority office.

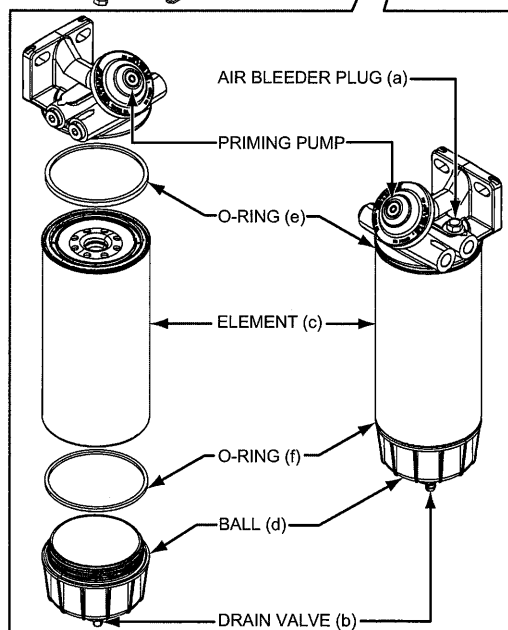

7

- (2) Installing the fuel filter element
- (A) Remove the dirt or foreign material adhered to the installation surface.
- (B) Rotate the new element (c) for about 1/2 turns after the element touches the O-ring (f) of the filter body to install on the filter body.
- Apply the fuel on the O-ring (f) surface.
 - Hand tighten. Do not use tool.
-

 **CAUTION**

**Do not re-use the element (c).
Use the new element supplied as element kit.
Take extra care not to damage the O-ring (f) by twisting.
Make sure that the O-ring (f) touches firmly on the seal face.**

- (C) After the O-ring (f) of the ball (d) contacts the element (c), rotate it further for about 1/2 to 3/4 turns to install the element (c).
- Do not reuse O-ring (f).
 - Apply fuel on the O-ring (f) face and install it.
 - Do not use tools. Hand-tighten.
- (D) Tighten the drain valve (b).
- (E) Start the priming pump and bleed air in the system.
-

 **CAUTION**

Make sure that the air bleed plug (a) is loose.

- (F) Install the air bleed plug (a).
-

 **CAUTION**

After work, wipe off the leaked fuel and start the engine and make sure that there is no more oil leak.

(3) Drain water from fuel filter

If the condition with the water mixed in the fuel filter is left, it may result in the premature damage and deterioration of the engine fuel system.

Thoroughly perform checking before starting daily works and drain the water if mixed in.

The condition can be visually checked through the ball section under the filter.

<Water drainage instruction>

- (A) Place a container to receive the drained water under the drain valve.
- (B) Loosen the air bleeder plug and the drain valve of the fuel filter to drain water accumulated at the inside of the fuel filter.

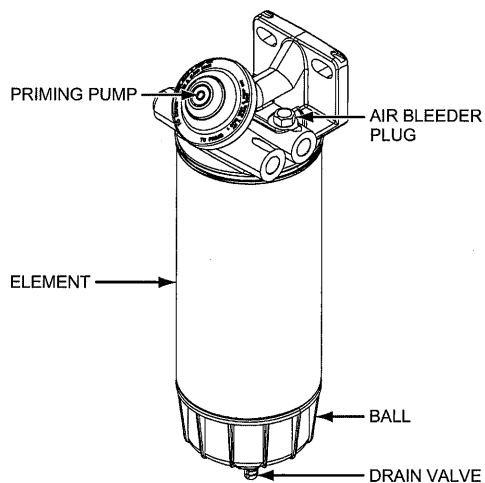

7

CAUTION

Drained water contains fuel, therefore, follow the disposing regulation specified in each region, when disposing of it.

- (C) Tighten the water drain valve and air bleeder plug.
- (D) Bleed air from the system.

9. CHANGING OF FUEL PRE-FILTER

- (1) Prepare container for drain oil.
- (2) Loosen air bleeder plug (a) and drain valve (b) and drain fuel from fuel pre-filter.
- (3) Fit the special filter wrench to the lower side of stiffening ribs and remove case (c).
Parts number : YN01T01044P1
- (4) Remove drain valve (b).
- (5) Remove dirt and foreign matter from attaching surface.
- (6) Apply light oil to new O-rings (d), (f) thinly, set it to case (c) and replace it with new element (e).
- (7) Fit case (c) to filter head by hand securely and tighten it with filter wrench.
- (8) Tighten air bleeder plug (a) and drain valve (b).
- (9) Bleed air according to the air bleeding procedure for fuel system.

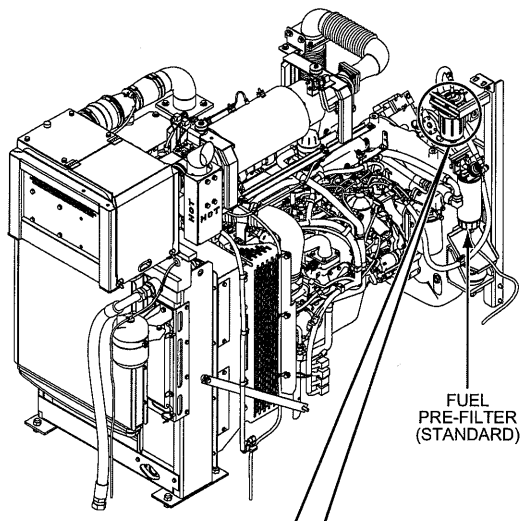

CAUTION

Do not reuse the element.
Replace old O-rings.
Be careful not to damage the O-rings by twisting.
Check to see if the O-rings firmly contact to the sealing surface.

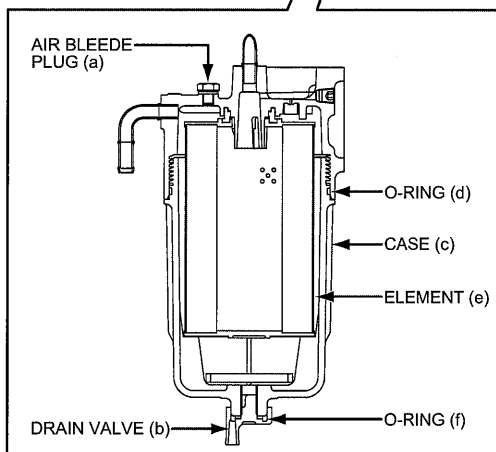

10. CHANGE OF HYDRAULIC OIL TANK RETURN FILTERS

CAUTION

Do not change hydraulic oil filter when hydraulic oil is hot.

After the oil has cooled and the pressure has been released, change the filter.

Failure to observe this precaution may result in a serious injury or loss of life.

Procedure of replacing the return filter

Remove the filter cover and replace the element and O-ring with new ones.

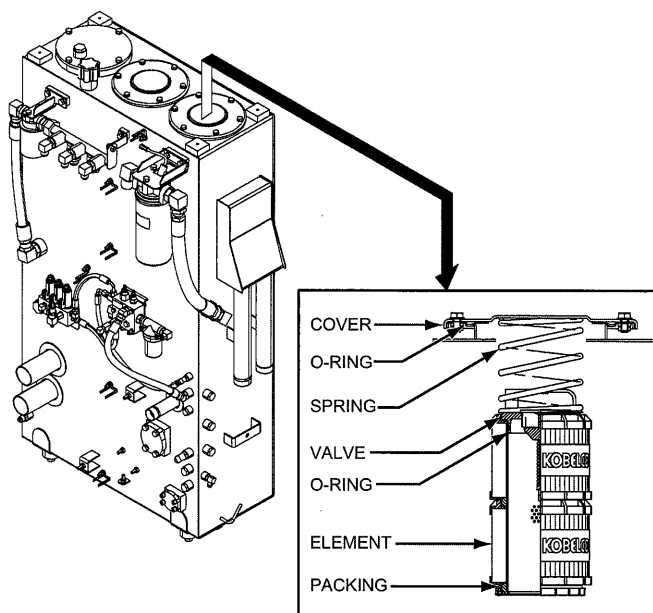

- (1) Remove the filter assembly and place it on the flat surface.

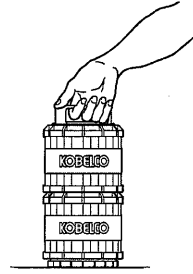

- (2) Hold the top mold plate and loosen the grip.

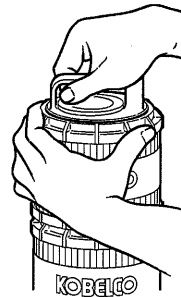

- (3) Pull out the grip assembly.

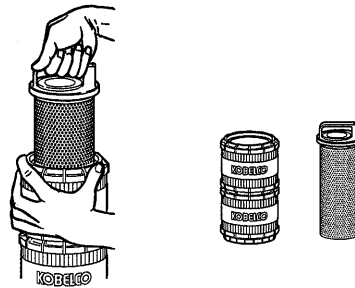

- (4) Turn over the filter.



- (5) Hold the plate on which the end plate is attached.

- (6) Loosen the end plate and replace the packing of the end plate with new one.

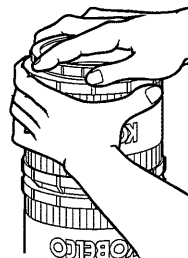

- (7) This is to complete the disassembly.
To assemble, take the reverse way.

CAUTION

Do not try to pull out the grip assembly by holding lower portion.

This may make disassembly harder since the element may be twisted and excessive force may be applied.

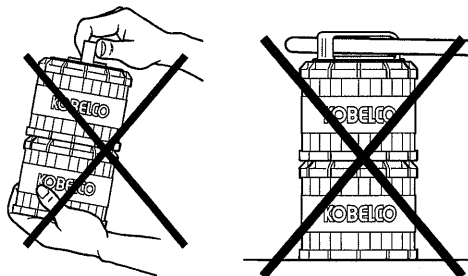
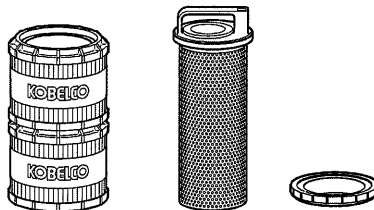

11. WASHING OF LINE FILTER (a)

12. WASHING OF LINE FILTER (b)

Remove the case, take out the filter and sufficiently wash it.

Replace the O-ring with a new one.



After stopping engine, wait for five minutes to release pressure.

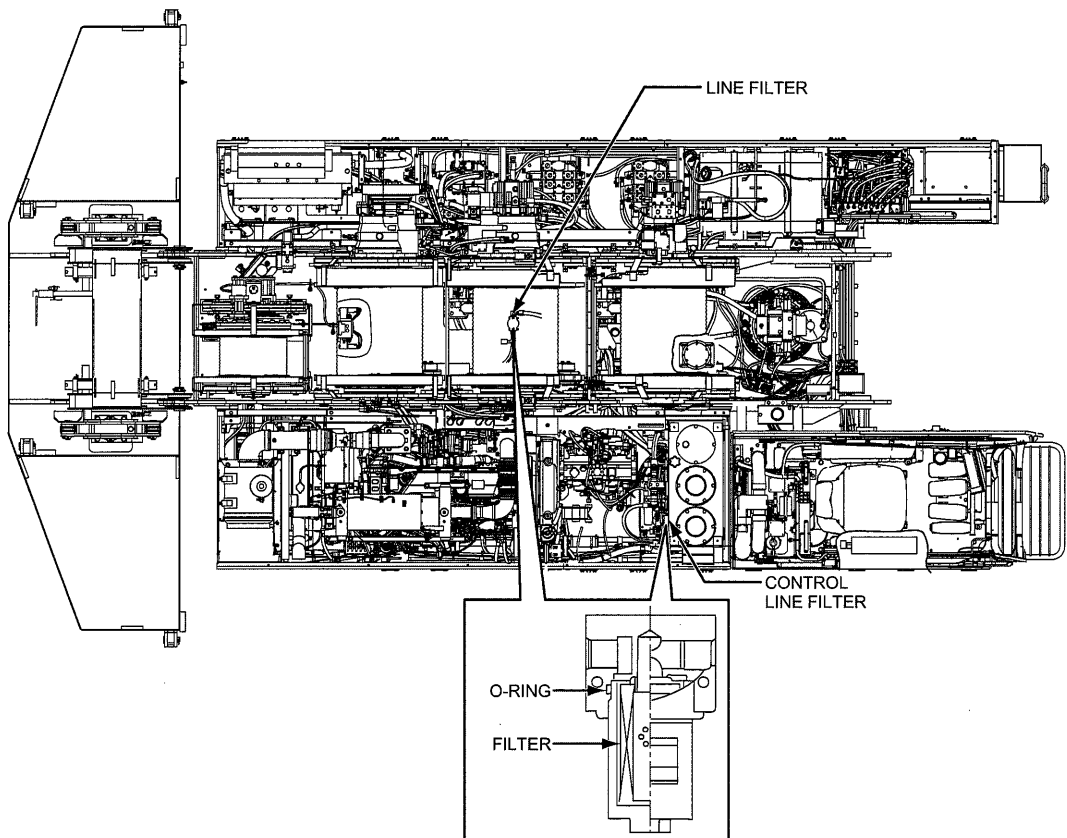

13. CHANGING OF AIR ELEMENT

If the element is exceptionally dirty and the element is deformed, replace the element with a new one early.

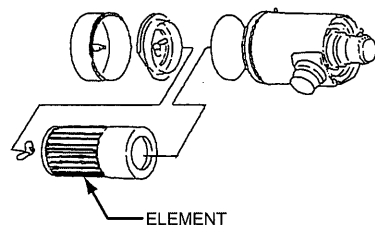

14. CHANGING HYDRAULIC OIL SUCTION FILTER

Remove the filter cover and replace the element and O-ring.
Perform this change when changing the hydraulic oil.

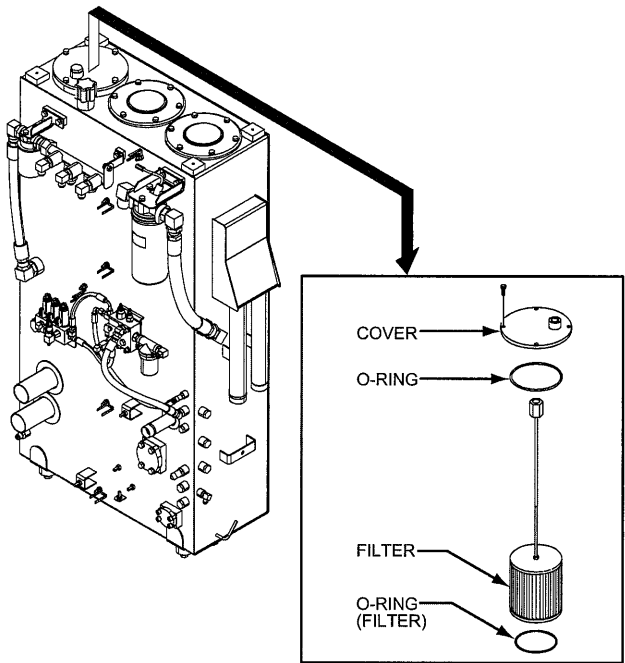

7

15. WASHING OIL FILL PORT STRAINER

Remove the air breather cap, take out the fill port strainer, and sufficiently wash it with washing liquid.

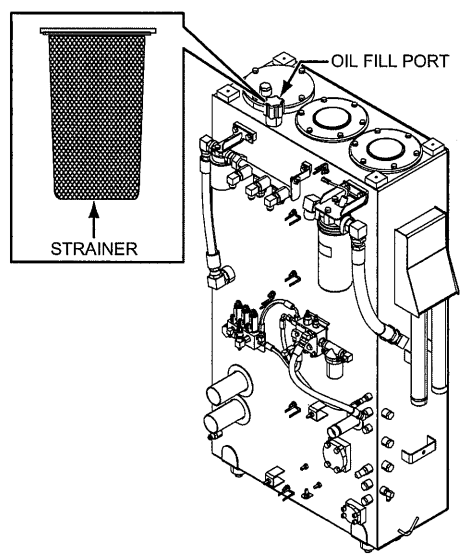

16. REPLACING FUEL FILTER (ON ENGINE)

The fuel filter is an element type.

Its purpose is to remove moisture and fine dirt particles from the fuel, the element is made from resin and paper.

Draining of fuel

- * Clean the area around the fuel filter before the start of work.
Otherwise dirt may enter.
- (1) Provide a waste oil container under the fuel filter.
 - (2) After loosening the drain plug, loosen the air bleeder plug and drain the fuel from the drain pipe.
- * At this time, drain all fuel from the filter.
When the element is replaced without draining all of the fuel, unfiltered fuel may remain inside the filter and later flow to the engine.

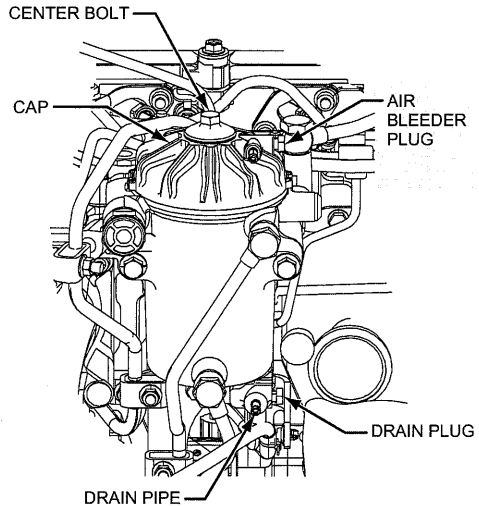
**⚠ WARNING**

- For safety and to keep the ground clean, always collect the fuel in a container.
- Carefully wipe off any fuel splashed onto engine parts.
Otherwise it may cause a fire.
- Keep burning cigarettes etc. away during work.
Otherwise there is the danger of parts catching fire.

- (3) Confirm that no more fuel flows from the drain pipe and then tighten the drain plug.

Tightening torque

Drain plug	4.9 to 8.9 N·m (3.6 to 6.6 ft·lbs)
------------	---------------------------------------

Removing the fuel filter element

Loosen the center bolt, remove the cap, and then remove the element.

Installing the fuel filter element

- (1) After replacing the element by a new one, install the cap and tighten the center bolt and the air bleeder plug.

Tightening torque

Center bolt	24.5 to 34.3 N·m (18.1 to 25.3 ft·lbs)
Air bleeder plug	4.9 to 8.9 N·m (3.6 to 6.6 ft·lbs)

- * Replace the gasket by the new gasket included in the element kit.
- (2) After installation, bleed the air from the fuel system.

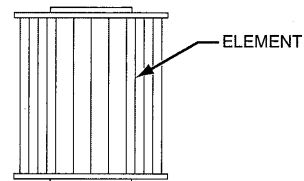

WARNING

After replacing the element, start the engine, make a test run, and confirm that there are no fuel leaks around the filter.

Leaking fuel may cause a fire.

- * Refer to P.7-89 for bleeding air from the fuel system.

17. CLEANING OR REPLACING DIESEL PARTICULATE FILTER

It is necessary to clean or replace the diesel particulate filter under the specified inspection interval.

Contact the nearest KOBELCO service shop to carry out cleaning or replacement.

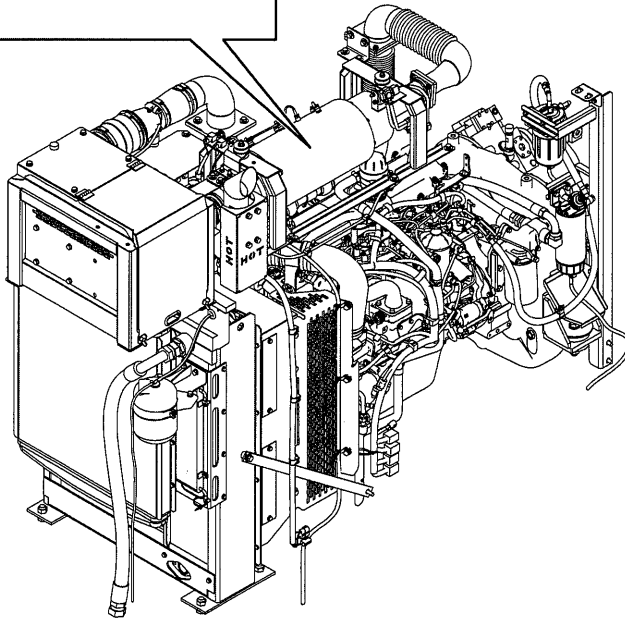
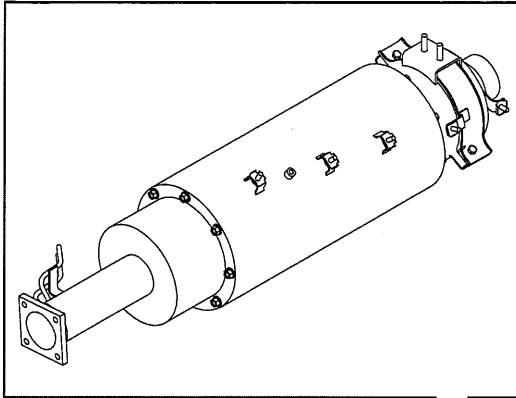

7.5 BATTERY INSPECTION

Check interval	Check item	Part No.
Monthly or every 100 hours	1. Check of battery electrolyte level.	
As required	2. Check of charge condition.	Battery : JJ72S00001P1 (165G51)

1. CHECKING BATTERY ELECTROLYTE LEVEL

If the battery electrolyte level is up to 10 mm (3/8 inch) above the plates, it is normal.

If insufficient, add distilled water.

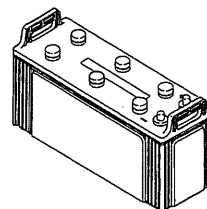

- (1) Checking the battery electrolyte level from the side level line :

Clean around the level lines with a wet cloth, and make sure that the electrolyte level is between the upper level and the lower level.

When the electrolyte level is lower than the level halfway between the upper level and the lower level, add battery electrolyte.

After replenishment, securely tighten the plug.

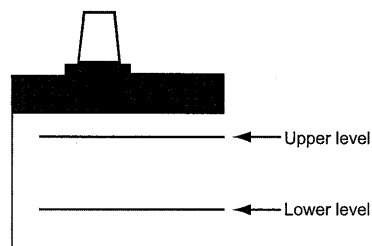

7

⚠ DANGER

NEVER clean the battery with a dry cloth.

Otherwise, static electricity occurs, leading to combustion and explosion.

Failure to observe this precaution may result in a serious injury or loss of life.

- (2) When you cannot check the battery electrolyte level from the side level line, or no level lines are provided on the side of the battery :

Detach the plug at the top of the battery, and check the battery electrolyte level from the filling port.

If the electrolyte level is lower than the sleeve, add battery electrolyte to the bottom of the sleeve.

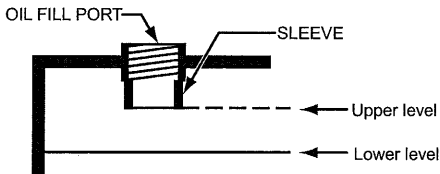

Sufficiently replenished

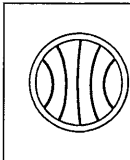

When the electrolyte level reaches the bottom of the sleeve, the electrolyte surface is swelled by surface tension, and the pole plates seen to be warp.

Insufficiently replenished

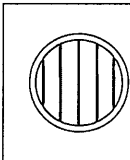

When the electrolyte level does not reach the bottom of the sleeve, the pole plates seen to be straight.

⚠ WARNING

- **Keep battery away from flame or spark.**
- **Never smoke while checking electrolyte level.**

This could cause the battery electrolyte to ignite and cause property damage, injury to personnel or loss of life.

2. CHECKING CHARGE CONDITION

The charge condition is judged by measuring the specific gravity of the battery electrolyte.

The normal specific gravity is 1.25 to 1.27 at 20°C (68°F) of electrolyte temperature.

If the specific gravity is lower than 1.25, charge the battery.

If the battery is not used for a long time, remove the battery from the machine and store it in a cold and dark place.

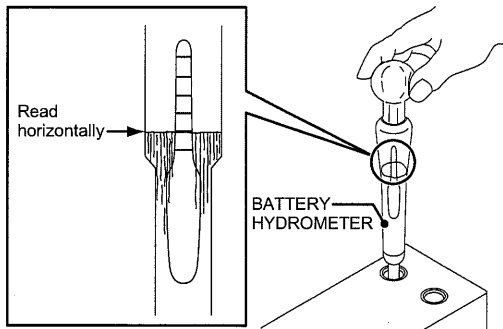

⚠ WARNING

Do not short across the battery terminals to check charging condition.

Failure to observe this precaution may result in a serious injury or loss of life.

3. CHANGING BATTERY

- (1) Place the machinery on the horizontal place and stop the engine.
- (2) When changing to new battery, make sure to change two batteries as one set.
- (3) When removing the battery cable, make sure to remove the earth side cable (\ominus side terminal) first.
- (4) After installed, put the red and black battery terminal covers.

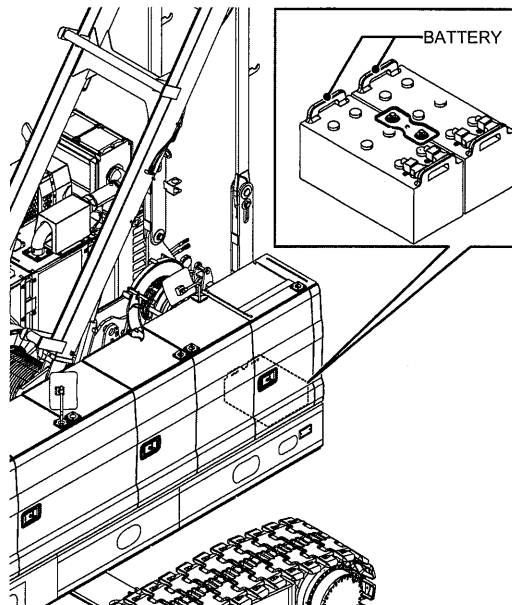

7

4. USING BOOSTER CABLES

CAUTION

Battery generates flammable hydrogen gas. This page is blank for editing convenience.

Do not use fire or spark near the battery.

Do not use or charge the battery when the battery fluid level is lower than limit level.

This may cause battery explosion.

Place the machine and machine on dry soil or concrete.

Placing on the steel plate makes machine grounded condition and may cause unexpected spark.

When the booster cables are connected, do not connect \oplus terminal and \ominus terminal.

This cause short circuit and is dangerous.

Note

This machine has DC24 V system.

Ensure to use DC24 V machine with large capacity enough to start as booster machine.

When the battery is discharged and booster machine battery is to be connected with the booster cables to start the engine, observe the following procedures.

- (1) Connecting the booster cables
 - (A) Stop the booster machine engine.
 - (B) Connect one end of the booster cable (a) (red) to the battery \oplus terminal of this machine and the other end to the battery terminal \oplus of the booster machine.
 - (C) Connect one end of the other booster cable (b) (black) to the battery \ominus terminal of the booster machine and the other end to the swing frame of this machine.

Since at the last connection, sparking will occur, connect it separating from the battery as much as possible.

 - (D) Make sure for connection and then start the booster machine engine.
 - (E) Start this machine engine.
 - (F) After the engine is started, remove the booster cable (b) and (a) in this order in the following procedure which is reverse way to the connection.

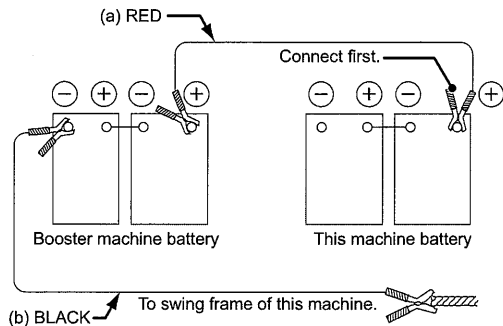

- (2) Removing the booster cable
 - (A) Remove the booster cable (b) (black) which is connected to the swing frame of this machine.
 - (B) Remove the booster cable (b) (black) which is connected to the \ominus terminal of the booster machine.
 - (C) Remove the booster cable (a) (red) which is connected to \oplus terminal of the booster machine.
 - (D) Remove the booster cable (a) (red) which is connected to \oplus terminal of this machine.
 - (E) Put the red and black battery terminal covers as the last step.

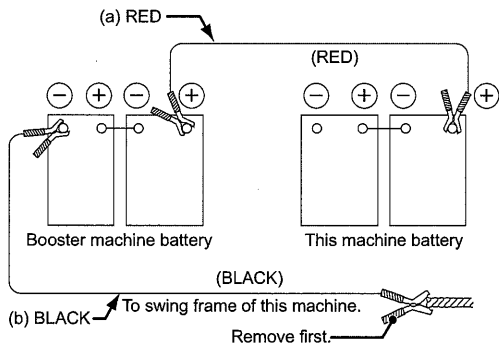

This page is blank for editing convenience.

7.6 LOCATION AND USE OF FUSE

While lifting two locks on the side face of the fuse box, open the cover.

Cover will not open unless the locks are completely unlocked.

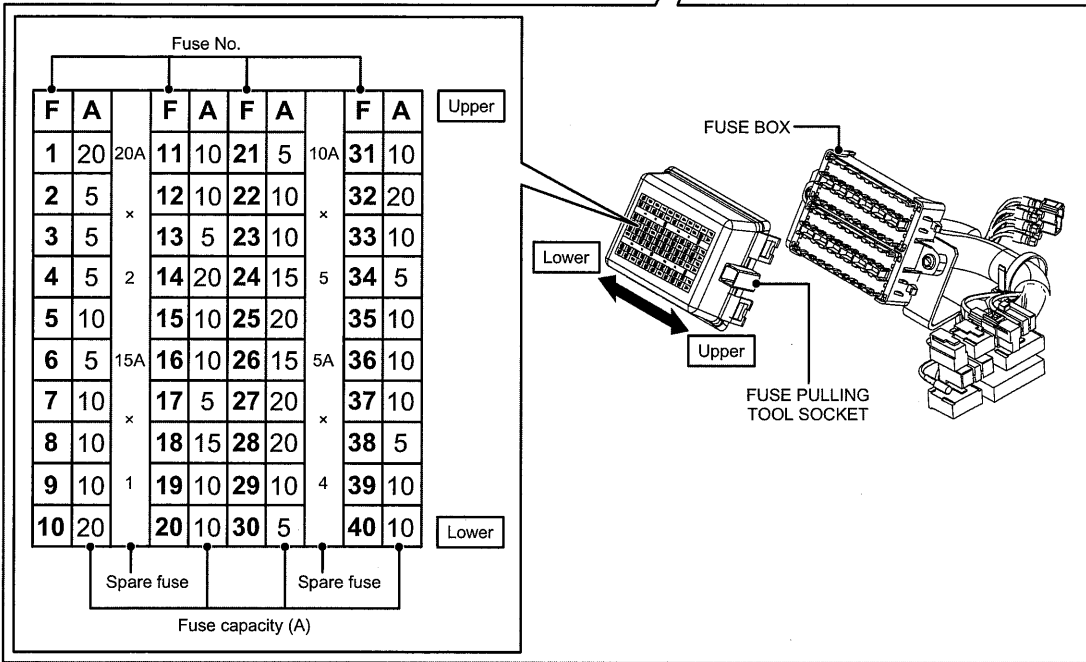
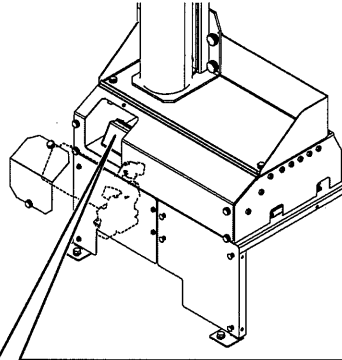

CLASSIFICATION OF FUSE USE

Fuse No.	Capacity	Line No.	Use
F1	20A	1A - 11	Main power supply, Work light
F2	5A	4-12	Sub battery voltage monitor
F3	5A	1B - 13	IT controller
F4	5A	1B - 14	Back-up (M/L, MC1, MC2, Radio)
F5	10A	2F - 15	Redundancy circuit
F6	5A	2F - 16	Release circuit
F7	10A	2F - 17	Control power (M/L)
F8	10A	2F - 18	Output power (M/L)
F9	10A	2F - 19	Control power (MC1)
F10	20A	2F - 20	Output power (MC1)
F11	10A	2F - 21	Auto-stop
F12	10A	2F - 22	Engine condition
F13	5A	52 - 23	Radio, One-way call
F14	20A	2G - 24	Wiper
F15	10A	2G - 25	Function lock
F16	10A	2G - 26	Remo-con
F17	5A	2G - 27	Monitor
F18	15A	2E - 28	Air conditioner
F19	10A	2E - 29	Air conditioner 2
F20	10A	2E - 30	Fun motor
F21	5A	51 - 31	Generation detect
F22	10A	471 - 32	PCV1 (P11C engine)
F23	10A	471 - 33	PCV2 (P11C engine)
F24	15A	2J - 34	ECU (+BF)
F25	20A	2J - 35	ECU (+B:J08E)
F26	15A	2J - 36	ECU (+B:P11C)
F27	20A	2I - 37	DC motor 1 for oil cooler
F28	20A	2I - 38	DC motor 2 for oil cooler
F29	10A	2I - 39	Swing flasher, Voice alarm
F30	5A	54 - 40	Starter
F31	10A	2H - 41	Control power (MC2)
F32	20A	2H - 42	Output power (MC2)
F33	10A	2H - 43	Solenoid valve (Confluence/independent)
F34	5A	2H - 44	Overhoist limit switch
F35	10A	2H - 45	Fuel pump, Cigarette lighter
F36	10A	2K - 46	Relay
F37	10A	2K - 47	Relay
F38	5A	2K - 48	Free fall
F39	10A	2K - 49	Light
F40	10A	2K -	Spare

7.7 OPERATION UNDER SEVERE CONDITIONS

OPERATION IN EXTREME COLD

- **Engine oil**

Use engine oil suitable to the atmospheric temperature. (JASO DH-2, API CJ-4, ACEA E-6)

Atmospheric temperature when engine starting	40°C to 0°C (104°F to 32°F)	10°C to -30°C (50°F to -22°F)	40°C to -30°C (104°F to -22°F)
Viscosity of oil	SAE 30	SAE 10W	SAE 10W-30

 **CAUTION**

When adding oil, do not mix different brand and type of oil.

 **CAUTION**

In order to keep good function of the diesel particulate filter, it is recommended to use the specified brand (recommended) engine oil.

- **Fuel**

Use fuel, suitable to the atmospheric temperature.

Before starting work, drain water.

After the work is finished, fill the tank as full as possible.

Ambient temp.	Type
-5°C (23°F) or more	JIS 2 light oil
-5°C to -15°C (23°F to 5°F)	JIS 3 light oil
-15°C (5°F) or less	JIS 3 special light oil

 **WARNING**

Use ultra low sulfur diesel fuel only (S50 : sulfur content lower than 50 ppm).

If fuel other than specified one is used, adverse affect may be caused to the engine or diesel particulate filter and white smoke or failure may be resulted.

- **Coolant**

Combine antifreeze (long life coolant) according to the atmospheric temperature.

Capacity of coolant : 30 L (7.9 gal)

Atmospheric temperature : °C (°F)	Volume of Cooling water : L (gal)	Volume of antifreeze : L (gal)
-4 (24.8)	27 (7.1)	3 (0.8) (10%)
-7 (19.4)	25 (6.6)	5 (1.3) (15%)
-13 (8.6)	22 (5.8)	8 (2.1) (25%)
-17 (1.4)	21 (5.5)	9 (2.4) (30%)
-21 (-5.8)	19 (5.0)	11 (2.9) (35%)
-25 (-13)	18 (4.8)	12 (3.2) (40%)
-31 (-23.8)	16 (4.2)	14 (3.7)(45%)
-40 (-40)	15 (4.0)	15 (4.0) (50%)

7

⚠ CAUTION

Sometimes, combination rate may be different depending upon brands.

- **Battery**

Sufficiently charge the battery.
(Maintain the specific gravity more 1.22.)

⚠ CAUTION

The electrolyte in a fully charged battery will resist freezing at lower temperatures better than a battery that is not fully charged.

⚠ CAUTION

After distilled water has been added, start and run the engine to mix water and electrolyte.

OPERATION IN EXTREME HEAT

- **Engine oil**

Use engine oil suitable to the atmospheric temperature.

(JASO DH-2, API CJ-4, ACEA E-6)

Atmospheric temperature when engine starting	40°C (104°F) or more	40°C to 0°C (104°F to 32°F)
Viscosity of oil	SAE 40	SAE 30

 **CAUTION**

In order to keep good function of the diesel particulate filter, it is recommended to use the specified brand (recommended) engine oil.

 **CAUTION**

Do not mix different brand and type of oil.

- **Coolant**

Do not use antifreeze (long life coolant), but mix anticorrosive to soft water and fill with it.

Wash the inside of the radiator with washing liquid.

- **Battery**

Always maintain the electrolyte level 10 mm (3/8 in.) above the plates.

OPERATION IN DUSTY PLACE

- **Air cleaner**
Perform washing and change of the element early.
- **Radiator, oil cooler**
Early clean the core not to allow dust to clog the core.
- **Filter, element**
Early replace with new ones.
- **Engine oil**
Early change oil.
- **Slewing ring gear**
Early lubricate.
- **Wire rope**
Early clean and lubricate.

7

OPERATION IN SEASIDE

- **Lubrication**
Thoroughly and carefully lubricate each point.
Lubricate connector sections not equipped with grease fittings.
- **Basic machine**
Sufficiently wash the basic machine, radiator and oil cooler to wash salt off.

7.8 HANDLING OF DIESEL PARTICULATE FILTER

Diesel particulate filter system burns soot automatically in the cleaning mode when the filter collected soot is accumulated to certain level.

In order to prevent failure of diesel particulate filter, observe the following points.

(* Soot accumulation time and burning time may vary depending on work condition.)

What is the diesel particulate filter

When the soot accumulated in the cleaner of the diesel particulate filter reaches a certain level, the unit starts burning process (regeneration).

With this, the cleaning capacity of the diesel particulate filter is kept to a satisfactory level.

In addition, with using the high performance catalyst and common-rail fuel injection system, it becomes possible to burn (regenerate) soot during the crane work.

- Do not use fuel other than specified one.
-

WARNING

Use ultra low sulfur diesel fuel only (S50 : sulfur content lower than 50 ppm).

If fuel other than specified one is used, adverse affect may be caused to the engine or diesel particulate filter and white smoke or failure may be resulted.

- Use recommended engine oil.
-

CAUTION

In order to keep good function of the diesel particulate filter, it is recommended to use the specified brand (recommended) engine oil.

- Do not modify the tail pipe.

⚠ CAUTION

If the tail pipe direction or length is changed, performance of the diesel particulate filter would be adversely affected. Do not modify the tail pipe. Should modification become necessary for a certain reason, contact the nearest KOBELCO service shop.

- Diesel particulate filter burns (regenerates) soot collected automatically.

⚠ CAUTION

Do not park the crane near the place where dry grass or inflammable objects are there. After the work or during cleaning mode, exhaust pipe area, muffler and exhaust gas become hot. Inflammable object may cause fire. Hot exhaust gas may also cause burns to personnel. Failure to observe these precautions may result in serious injuries or loss of life.

When the diesel particulate filter is working, take care of the following points.

Due to some work conditions, burning (regeneration) of the soot collected in the diesel particulate filter may not be completed.

In such case, "soot burning (regenerate) icon" is indicated on the main monitor.

This is to resume function of the diesel particulate filter and is not a failure.

When "soot burning (regenerate) icon" is indicated on the main monitor, push the soot burning (regenerate) icon to burn soot (regeneration).

If the crane is left idling for long time, idling speed may increase and load valve may actuate to prevent from exhausting white smoke.

The diesel particulate filter may cause increase of engine idling speed and may actuate load valve and lever operation may becomes impossible under the following case.

This is to raise the exhaust temperature and to clean the exhaust gas but not a failure.

- When the “soot burning (regenerate) icon” is indicated on the main monitor and the icon is pushed to burns (regenerate) the soot. (Lever work becomes impossible.)
- When it becomes auto-regeneration mode during work. (Lever work becomes possible.)
- If the low exhaust air temperature continues for long time (such as longer than 1 hour idling), regeneration motion may be interrupted once when the lever is turned on to work.
This regeneration may resume whenever lever is returned to the neutral within a certain period of time.

The diesel particulate filter has the following features.

- Since the exhaust gas is cleaned with the diesel particulate filter, exhaust gas has different smell compared with the conventional machines.
- At machine start, white smoke comes out of the tail pipe.
This is moisture and is normal.
- During soot burning (regenerating) white smoke may come out from the muffler area.
This is exhaustion of moisture accumulated around the muffler area and is normal.

7.9 MACHINE STORAGE

1. Short term storage (period of 30 days or less)
 - Clean, sufficiently dry, and then carefully lubricate the entire machine.
 - Cover the machine to protect it from dust.
2. Long term storage (longer than one month and less than 1 year)
 - Clean, sufficiently dry, and then carefully lubricate the entire machine.
 - Sufficiently grease the slewing ring gear.
 - Replace the reduction unit gear oil and hydraulic oil with fresh oil.
 - Replace all filters with new ones.
 - Remove the battery and store it in a cool and, dark place.
 - Apply thin coat of oil to places that are prone to rust.
 - Completely drain coolant and post a "No Water" sign.
 - Cover the entire machine to protect it from dust.

As for the storage of the engine area, refer to the engine manual (proper operating-long time storage).

7.10 TIGHTENING TORQUE VALUES

1. Unless otherwise specified, torque all metric screws and bolts on this machine to the values shown in the table below.

Nominal	Metric coarse thread screw (Plated)				
	4T		7T		2 face width : mm (in.)
	Tightening torque : N·m (ft·lbs)		Tightening torque : N·m (ft·lbs)		
	Dry	Lubricated	Dry	Lubricated	
M6	4.6 to 5.6 (3.4 to 4.1)	3.9 to 4.7 (2.9 to 3.5)	10 to 12.2 (7.4 to 9.0)	8.4 to 10.2 (6.2 to 7.5)	
M8	11.1 to 12.2 (8.2 to 9.0)	9.5 to 10.5 (7.0 to 7.7)	24.4 to 30.1 (18 to 22.2)	20.2 to 24.8 (14.9 to 18.3)	13 (1/2)
M10	22 to 27 (16.2 to 19.9)	18.5 to 22.7 (13.6 to 16.7)	47.6 to 58.2 (35.1 to 42.9)	40.6 to 49.6 (29.9 to 36.6)	17 (11/16)
M12	37.1 to 45.3 (27.4 to 33.4)	32.7 to 39.9 (24.1 to 29.4)	81.0 to 99.2 (59.7 to 73.2)	68.8 to 84.0 (50.7 to 62.0)	19 (3/4)
M14	59.1 to 72.3 (43.6 to 53.3)	50.2 to 61.5 (37.0 to 45.4)	129 to 157 (95.1 to 115.8)	109 to 133 (80.4 to 98.1)	22 (7/8)
M16	90 to 110 (66.4 to 81.1)	75.9 to 92.7 (56.0 to 68.4)	194 to 238 (143 to 176)	163 to 199 (120 to 147)	24 (15/16)
M18	123 to 151 (91 to 111)	105 to 129 (77.4 to 95.1)	274 to 334 (202 to 246)	229 to 281 (169 to 207)	27 (1-1/16)
M20	174 to 212 (128 to 156)	146 to 178 (108 to 131)	379 to 463 (280 to 341)	318 to 388 (235 to 286)	30 (1-3/16)
M22	229 to 281 (169 to 207)	194 to 238 (143 to 176)	503 to 615 (371 to 454)	423 to 517 (312 to 381)	32 (1-1/4)
M24	300 to 366 (221 to 270)	238 to 292 (176 to 215)	643 to 787 (474 to 580)	520 to 636 (384 to 469)	36 (1-7/16)
M27	432 to 528 (319 to 389)	353 to 431 (260 to 318)	943 to 1153 (696 to 850)	768 to 938 (566 to 692)	41 (1-5/8)
M30	591 to 723 (436 to 533)	494 to 604 (364 to 445)	1279 to 1563 (943 to 1153)	1075 to 1315 (793 to 970)	46 (1-13/16)
M33	794 to 970 (586 to 715)	661 to 809 (488 to 597)	1721 to 2101 (1269 to 1550)	1446 to 1768 (1067 to 1304)	50 (1-15/16)
M36	1023 to 1251 (755 to 923)	856 to 1046 (631 to 771)	2205 to 2659 (1626 to 1961)	1843 to 2253 (1359 to 1662)	55 (2-3/16)

Nominal	Metric fine thread screw (Plated)				2 face width : mm (in.)
	4T		7T		
	Tightening torque : N·m (ft·lbs)		Tightening torque : N·m (ft·lbs)		
	Dry	Lubricated	Dry	Lubricated	
M8	11.6 to 14.2 (8.6 to 10.5)	9.8 to 12 (7.2 to 8.9)	25.6 to 31.2 (18.9 to 23)	21.1 to 25.9 (15.6 to 19.1)	13 (1/2)
M10	22.9 to 28.1 (16.9 to 20.7)	19.4 to 23.8 (14.3 to 17.6)	49.4 to 60.4 (36.4 to 44.5)	42.7 to 51.7 (31.5 to 38.1)	17 (11/16)
M12	40.6 to 49.6 (29.9 to 36.6)	34.4 to 42 (25.4 to 31)	87.3 to 106.7 (64.4 to 78.7)	73.2 to 89.4 (54 to 65.9)	19 (3/4)
M16	94 to 116 (69.3 to 85.6)	79.4 to 97 (58.6 to 71.5)	202 to 248 (149 to 183)	172 to 210 (127 to 155)	24 (15/16)
M20	185 to 227 (136 to 167)	157 to 191 (116 to 141)	406 to 496 (299 to 366)	335 to 409 (247 to 302)	30 (1-3/16)
M24	318 to 388 (235 to 286)	265 to 323 (195 to 238)	688 to 840 (507 to 620)	573 to 701 (423 to 517)	36 (1-7/16)
M30	635 to 777 (468 to 573)	529 to 647 (390 to 477)	1393 to 1703 (1027 to 1256)	1156 to 1412 (853 to 1041)	46 (1-13/16)
M36	1058 to 1294 (780 to 954)	882 to 1078 (651 to 795)	2311 to 2825 (1705 to 2084)	1922 to 2350 (1418 to 1733)	55 (2-3/16)

2. Tightening torque of bolt, nut with special specification are listed below.
 Tightening torque shall be within $\pm 10\%$ of the value in the list.

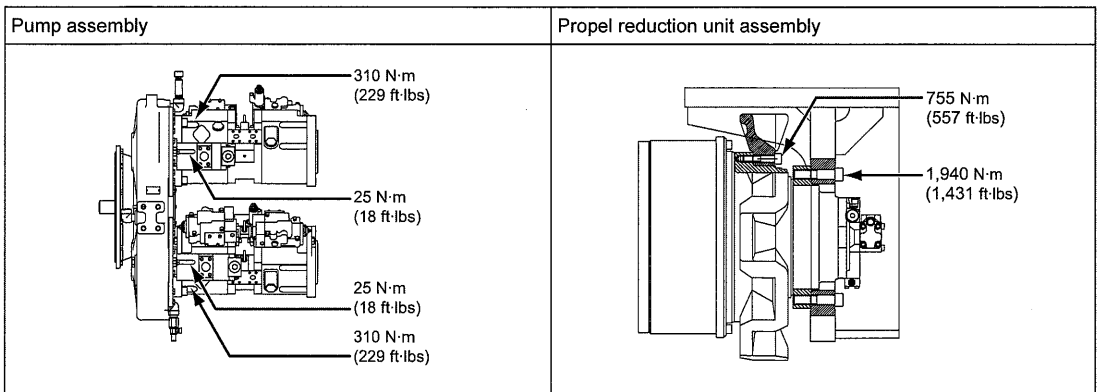
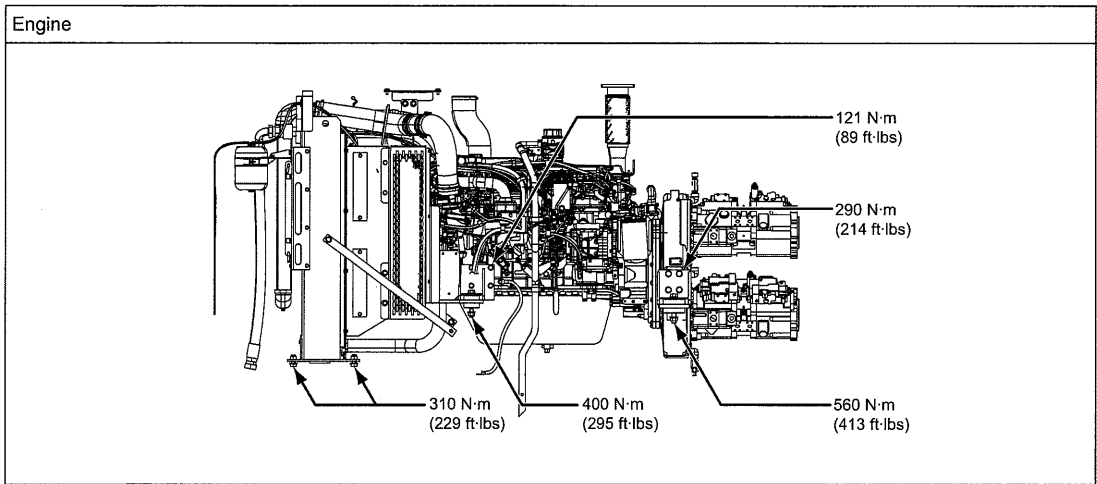
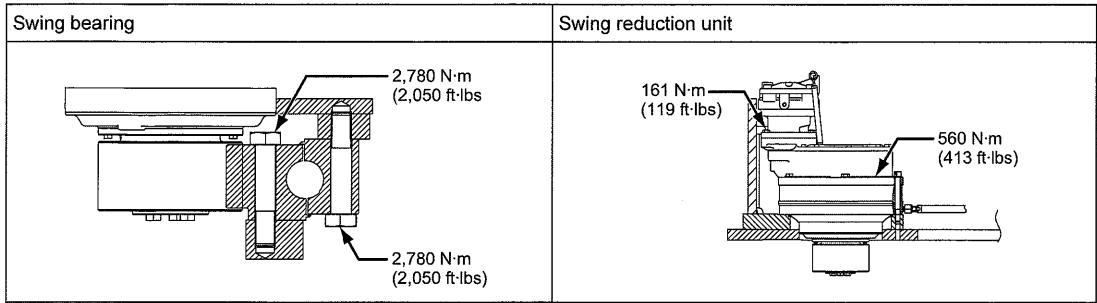

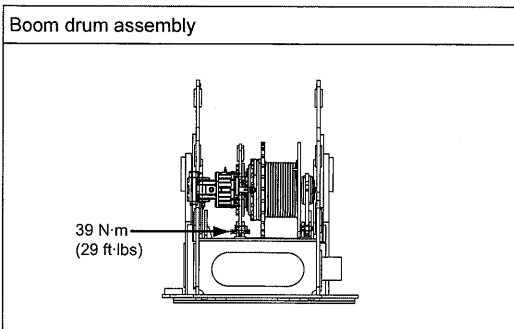
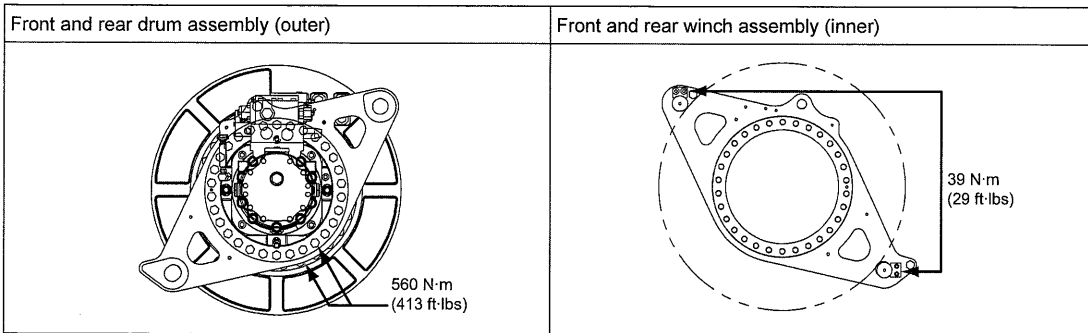

Apply Loctite #242 or #243 or equivalence to the bolts and nuts.

For maintenance, contact our KOBELCO authorize distributor.

7.11 PERIODICAL REPLACING SECURITY PARTS

In order to use the machine safely for long time, it is requested to inspect and repair the machine periodically.

Therefore replace the following parts periodically to keep safety of the machine.

These parts may cause material deterioration by aging, wear or fatigue and may lead to serious accident.

It would be difficult to judge these parts life by operation or visual inspection.

If there is any abnormality noticed on the periodic inspection maintenance time, replace these parts with new ones even before periodic replacement time as shown here.

Contact KOBELCO service shop for part replacement.

1. Hose damage related clutch brake and control pressure may lead to the serious accident.

Replace the following hoses as periodical replacing security parts on every 2 years or less.

No.	Hose related periodical replacing parts	Replacement Interval (Recommended)
Front drum nega. posi-clutch main hose	Front drum CLM	GG20H01053DC
	Front drum ESM	GG20H01054DC
	Rear drum CLA	GG20H01053DB
	Rear drum ESA	GG20H01054DB
	Third drum CLT	GG20H01053DD
	Third drum EST	GG20H01054DD
Foot brake control hose	Front drum FBM	ZX23M06190
	Rear drum FBA	ZX23M06190
	Third drum FBT	ZX23M06330
Pressure control hose (Pump to line filter)	Relief valve	ZX33M08082
Pressure control hose (Line filter to accumulator)	Manifold	ZX23M08230
Pressure control hose (Accumulator to valve block)	Under floor block	ZX23M06130
	Left deck front P block	ZX23M08270
	2 section valve (Remocon. cut)	ZX23M06120
	Remocon. valve (Brake pedal)	ZX23M08032
	4 section valve (Free fall)	ZX23M08170
	Remocon. valve (Third brake pedal)	ZX23M08076
	2 section valve (Third free fall)	ZX33M08120
		2 years

7

As for all hydraulic hoses, inspect them periodically and replace them if oil oozing or leaking are found.

- The guy lines are subject to damage caused by internal fatigue or corrosion and can not be judged for their replacement time by outer visual inspections.

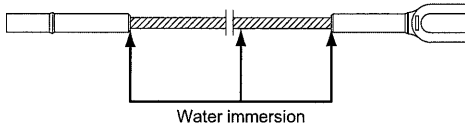

If the internal damage or corrosion is progressed, guy line may be broken and may cause serious accident.

Make sure to replace periodically based on work condition.

Guy line related periodically replacing parts	Recommended Interval
1. General crane work.	6 years
2. Crane work main with clamshell and bucket work as sub.	4 years
3. Only for lifting magnet, clamshell and hammer grab.	2 years

CRANE GUY LINE

Boom guy line chart					Connector type
Symbol	Guy line dimension		Part number	Remarks : m (ft.)	
	Diameter : mm (in.)	Length : m (ft. in.)			
A	34 (1-5/16)	7.1 (23 3-1/2)	GK71A00005D1	Boom tip	
B	34 (1-5/16)	3.05 (10)	JJ71A00006D1	3.0 (10) Boom insert	
C	34 (1-5/16)	6.10 (20)	JJ71A00006D2	6.1 (20) Boom insert	
E	34 (1-5/16)	12.20 (40)	JJ71A00006D4	12.2 (40) Boom insert	

CRANE JIB GUY LINE

Kind of guy line				Connector type
Symbol	Guy line dimension		Part number	
	Diameter : mm (in.)	Length : m (ft. in.)		
J	22 (7/8)	40.0 (131 2-13/16)	2430R317D5	
K	22 (7/8)	2.44 (8 1/16)	2430R316D1	
F	22 (7/8)	19.34 (63 5-7/16)	2430R317D2	
G	22 (7/8)	5.88 (19 3-1/2)	2430R316D3	
H	22 (7/8)	11.75 (38 6-5/8)	2430R316D2	

7.12 ADJUSTMENT

7.12.1 ADJUSTMENT OF FRONT, REAR, THIRD DRUM LOCKS

WARNING

Do not adjust the drum locks until the boom, hook block, and load have been lowered to the ground. Failure to observe this precaution may result in a serious injury or loss of life.

1. Pull the drum lock knob in the "LOCK" position and check to see that the pawl is engaged in the bottom of the drum ratchet. If the pawl is not engaged in the bottom of the ratchet, adjust the spring length to allow the pawl to be engaged.
2. With the "RELEASE" position, adjust the respective dimension as shown in the figure to the right.
3. Push the drum lock knob in the "RELEASE" position and check to see that the pawl is clear of the ratchet by at least 20 mm (13/16 in.).
4. Operate the knob to the "LOCK" position, and to the "RELEASE" position and confirm that the pawl moves smoothly.

WARNING

Take extra-care on the rotating drum to prevent accident of being caught. Failure to observe this precaution may result in serious injuries or loss of life.

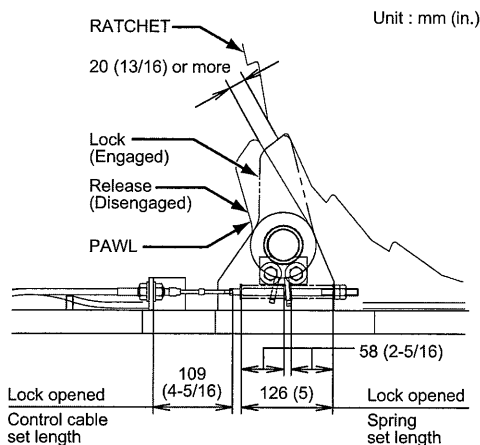

FRONT, REAR, THIRD DRUM LOCKS

7.12.2 ADJUSTMENT OF BOOM DRUM LOCK



Do not adjust the boom hoist drum lock until the boom has been lowered to the ground.

Failure to observe this precaution may result in a serious injury or loss of life.

1. Pull the drum lock knob in the "LOCK" position and check to see that the pawl is engaged in the bottom of the drum ratchet with the drum lock condition.
If the pawl is not engaged in the bottom of the ratchet, adjust the spring dimension to allow the pawl to be engaged.
2. With the "RELEASE" position, adjust the respective dimension as shown in the figure to the right.

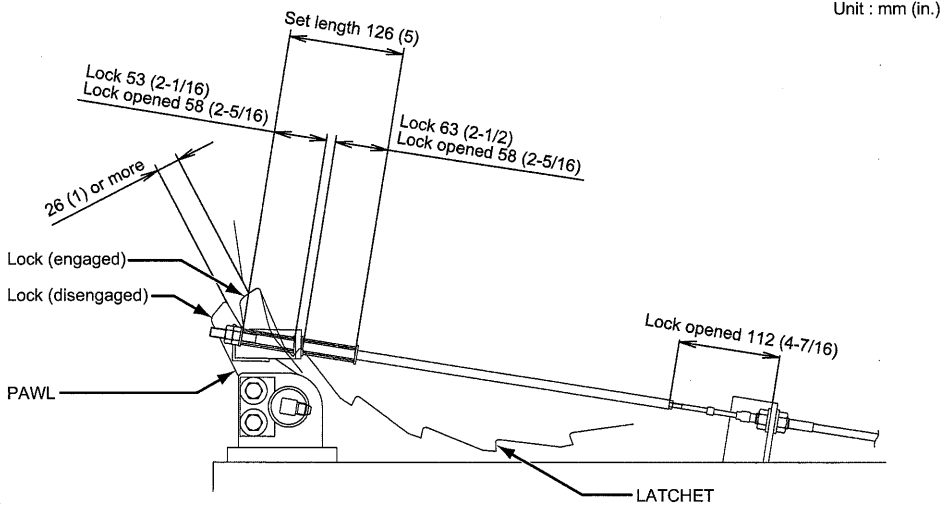

3. Push the drum lock knob in the "RELEASE" position, and check to see that the pawl is clear of the ratchet by at least 26 mm (1 in.).
4. Operate the knob to the "LOCK" position, and to the "RELEASE" position, and confirm that the pawl moves smoothly.

⚠ WARNING

Do not adjust the boom hoist drum lock until the boom has been lowered to the ground.

Failure to observe this precaution may result in a serious injury or loss of life.

7.12.3 CRAWLER SHOES ADJUSTMENT

If the crawler tension is high, the shoes wear quickly and connection between two shoes could break.

On the other hand, if the tension too loose, the shoes may run off the drive tumbler or idler wheel during propel.

To prevent these, it is necessary to adjust shoe tension.

Propel forward about 7 m (23 ft.) with the drive tumbler at rear and then adjust the shim to make upper shoe slackening to be 10 to 20 mm (3/8 to 7/8 in.).

To adjust shoe tension, proceed as follows :

1. Propel the machine forward about one crawler length so that the slack in the crawler shoes appear on the top of the crawler.
2. Remove all the shims from shim pack (a).
3. Position the hydraulic jack between the bracket and block of the side frame. Operate the jack to push the idler wheel and remove the slack in the shoes.
4. Insert the shims removed from pack (a) in step (2) into the vacant room of pack (b). Insert the remaining shims into pack (a).
5. After the shims are installed, install the mud cover (c) on the shim installation area (a). Install the cover (d) to the elongated hole area of both crawler frames.

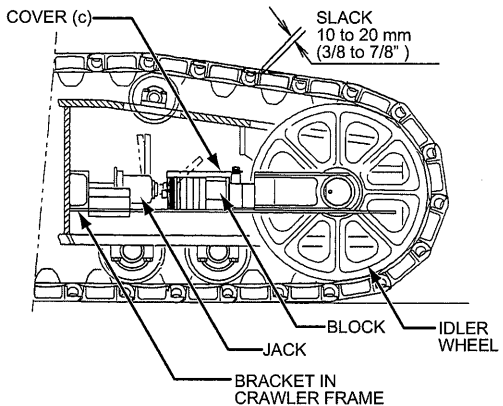
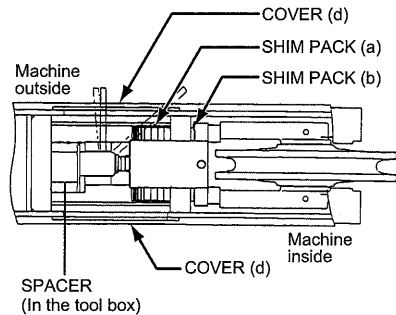

Equalize the tension in right and left crawler tracks.

7.13 CONSUMABLE PARTS LIST

1. OIL/GREASE

For the recommended oil and grease, refer to the "KOBELCO GENUINE LUBRICANT CHART" on P.7-51, and use genuine KOBELCO parts.

For the battery electrolyte and the window washer liquid, use commercial items.

2. FILTER ELEMENT

For the recommended filter element, refer to the chart on P.7-83.

3. FUSE

For the recommended fuse, refer to the chart on P.7-106.

4. WIRE ROPE

For the recommended wire rope, refer to the article 6 "WIRE ROPE".

5. LIGHT AND MIRROR

6. BATTERY

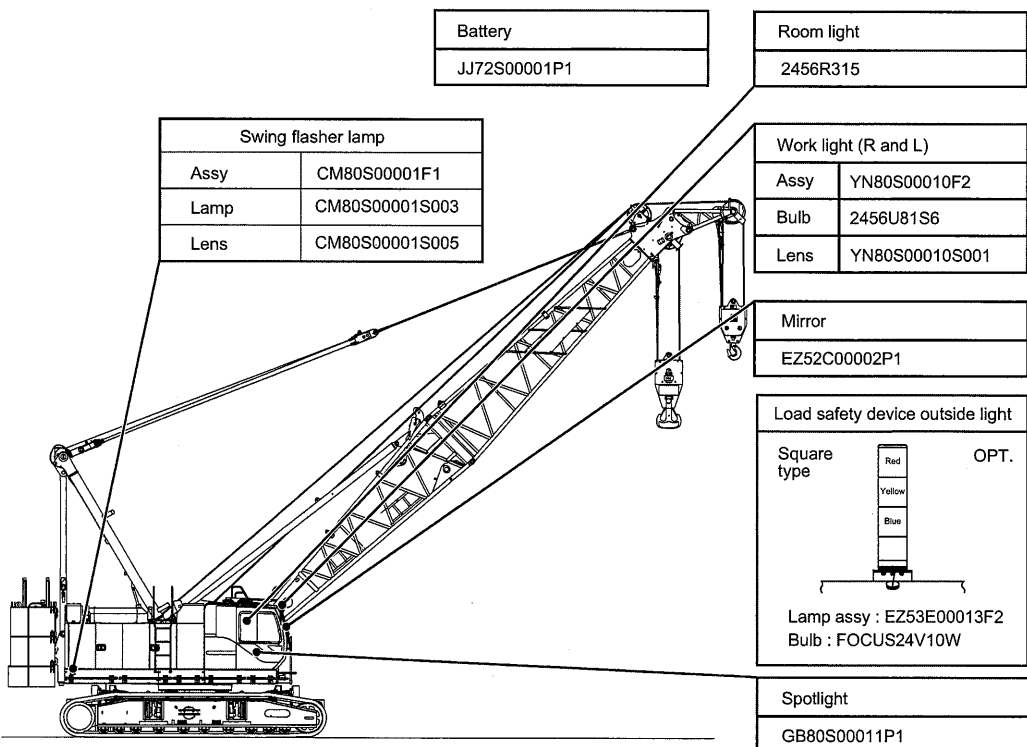

7. WINDOW GLASS AND WIPER

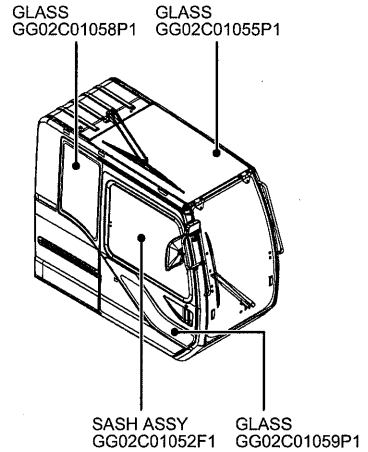
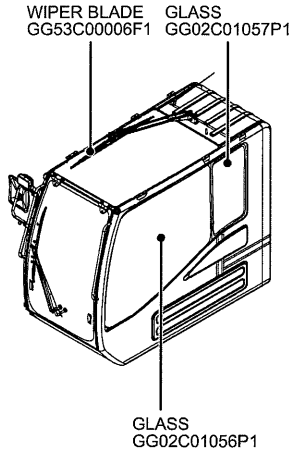
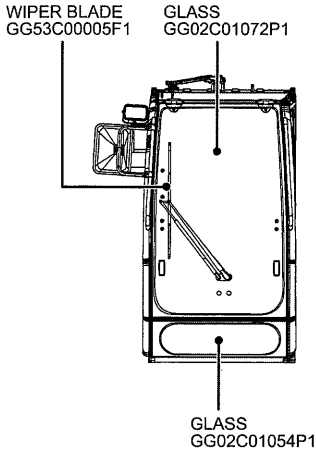

8. HOOK OVERHOIST LIMIT SWITCH

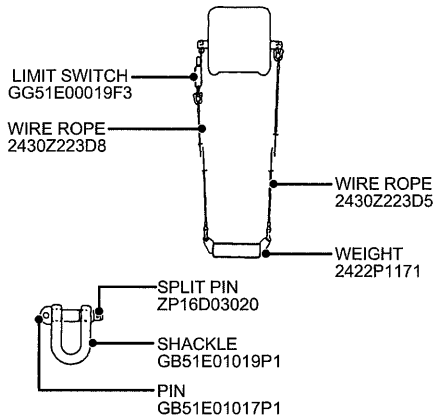
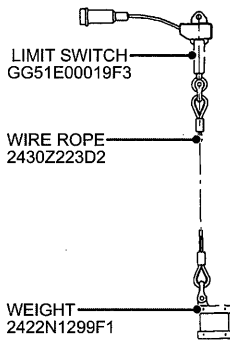

9. CABLE REEL

For crane hook overhoist	GG82S00005F1
For crane jib hook overhoist	GG82S00003F1

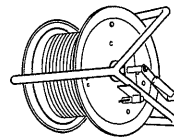







10. KEY



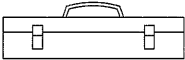

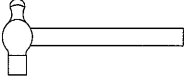
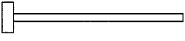

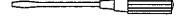





ENGINE
DOOR
GUARD

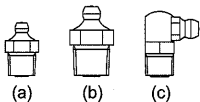
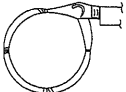
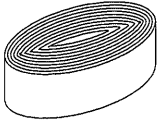

YN50S01010P1

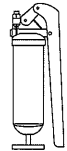
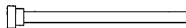
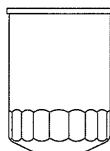
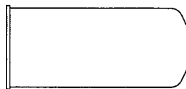
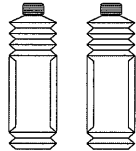
11. TOOL

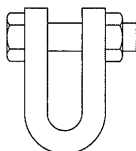
Name	Part No.	Detail
TOOL BOX	4027R1	
PLIERS	2421R393	
ADJUST WRENCH	ZT12D20000 (24 mm [1-15/16"]) ZT12D37500 (44 mm [2-3/4"])	
HAMMER	2421R397	
	21Z72D4	
⊕ DRIVER	GB01T01008D1	
⊖ DRIVER	2421R395D2 (5.5 mm [3/16"])	
ADAPTOR (When adjustment of shoe)	2416T9379	

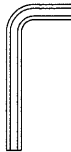
Name	Part No.	Detail						
JACK (When adjustment of shoe)	2421Z228D18							
RATCHET HANDLE	2406R527 (□ 12.7) ZT31B19500 (□ 19)							
EXTENSION BAR	2406Z623D4 (□ 12.7) ZT31D19400 (□ 19)							
SPANNER	ZT12A55000 (55 mm [2-3/16"])							
SOCKET	<table border="0"> <tr> <td>2408R587D1 (17 mm [11/16"])</td> <td>2408R587D4 (24 mm [15/16"])</td> </tr> <tr> <td>2408R587D2 (19 mm [3/4"])</td> <td>ZT32A30000 (30 mm [1-3/16"])</td> </tr> <tr> <td>2408R587D3 (22 mm [7/8"])</td> <td>ZT32A55000 (55 mm [2-3/16"])</td> </tr> </table>	2408R587D1 (17 mm [11/16"])	2408R587D4 (24 mm [15/16"])	2408R587D2 (19 mm [3/4"])	ZT32A30000 (30 mm [1-3/16"])	2408R587D3 (22 mm [7/8"])	ZT32A55000 (55 mm [2-3/16"])	
2408R587D1 (17 mm [11/16"])	2408R587D4 (24 mm [15/16"])							
2408R587D2 (19 mm [3/4"])	ZT32A30000 (30 mm [1-3/16"])							
2408R587D3 (22 mm [7/8"])	ZT32A55000 (55 mm [2-3/16"])							
TUBE	2420T3100							
GREASE NIPPLE	(a) ZG91S02000 (PT1/8) (b) ZG91S04000 (PT1/4) (c) ZG91U02000 (PT1/8)							
FILTER WRENCH	2421R171							
TAPE	GG11E00029D1							

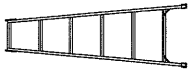
Name	Part No.	Detail
GREASE PUMP	2421R107	
HOSE (For grease pump)	44Z186	
CARTRIDGE	2446U141S2	
CARTRIDGE	2446U254S3 (Only with free fall)	
GREASE	2421R114D11	
GEAR OIL (For swing gear)	21Z16D5	
SHACKLE	GK01T01018D3×4 (For 10.0 t) 2420Z605D7×2 (For 2.0 t)	
PIPE WRENCH	2421R152	
SCREW KEY	ZT22A14000	

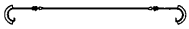
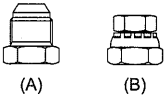
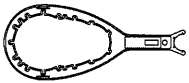
Name	Part No.	Detail
STEP LADDER	2429Z291	
CHAIN	GK32T01006F1	
SUPPORT ASSY	JJ01T01012F1	
PLUG	(A) 2444Z2728D2 (B) 2444Z2729D2	
WRENCH (For engine fuel prefilter)	YN01T01044P1	

7.14 MEASURES REQUIRED FOR FRONT, REAR WINCH MONITORING

CAUTION

Refer to the information on the general inspection of the front, rear winch too.

7.14.1 THEORETICAL SERVICE LIFE

The theoretical service life is determined from certain operating conditions and a theoretical operating time assumed by the design engineer when calculating and dimensioning the winches of this crane.

The winches of this crane are classified as follows.

(ISO 4301/1, FEM 1.001, DIN Calculating code for power unit)

Power unit group	M3
Load spectrum	Q 1 (L 1)
Load spectrum factor	$K_m = 0.125$
Theoretical service life	$D = 3,200 \text{ h}$

CAUTION

The theoretical service life is not the same as the real (actual) service life of a winch.

The real service life of a winch is affected by a number of additional external factors, such as :

1. Overloading caused by improper use of the crane.	
2. Insufficient maintenance	Oil is not changed at the specified intervals.
3. Operating errors	Extreme acceleration or deceleration of the load. Sudden load drops and stops while lifting load.
4. Improper maintenance	Wrong oil used. Incorrect filling quantity. Contamination during oil change.
5. Improper assembly during maintenance and repair work.	
6. Leaks which were ignored.	
7. Improper adjustment of safety devices.	
8. Concealed damage caused by accidents.	
9. Extreme environmental conditions	Extreme low or high temperatures. Severe climate condition. Dust and dirt.

7.14.2 USED PROPORTION OF THEORETICAL SERVICE LIFE

The crane operator must perform a crane inspection at least once a year (ISO 9927-1).

This includes establishing the proportion of theoretical service life that has been used.

If required, the crane operator is to appoint an expert for this assessment.

The actual operating conditions (load spectrum) and the operating hours of the hoists are to be determined for each inspection interval when establishing the proportion of theoretical service life that has been used.

The operator is responsible for proper documentation in the crane logbook.

Determining the operating conditions (Load spectrum)

The load spectrum of the crane is divided into groups :
(also refer to ISO 430/1, JIS 8822-2)

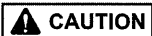

When establishing the load spectrum, the existing wire cable condition is used as a standard, i.e. under certain circumstances, the crane can be supporting a heavy load, whereby the winch is actually supporting a light load.

Therefore, the following graphic representation of the load spectrum refers to the winch's wire cables.

Collective load class	Definition	Proportion of operating time	Collective load factor Km =	Graphic representation
Light Q1 L1	Power units or parts thereof that are rarely subject to maximum load, but are constantly subject to minimal loads	<ul style="list-style-type: none"> • 10% of the operating time with highest load (dead load + 1/1 payload) • 40% of the operating time with dead load + 1/3 payload • 50% of the operating time with dead load only 	0.125	
Medium Q2 L2	Power units or parts thereof that are fairly often subject to maximum load, but continuously subject minimal loads	<ul style="list-style-type: none"> • 1/6 of the operating time with highest load (dead load + 1/1 payload) • 1/6 of the operating time with dead load + 2/3 payload • 1/6 of the operating time with dead load + 1/3 payload • 50% of the operating time with dead load only 	0.25	
Heavy Q3 L3	Power units or parts thereof that are often subject to maximum load and continuously subject to medium loads	<ul style="list-style-type: none"> • 50% of the operating time with highest load (dead load + 1/1 payload) • 50% of the operating time with dead load only 	0.5	
Very heavy Q4 L4	Power units or parts thereof that are regularly subject to loads close to maximum load	<ul style="list-style-type: none"> • 90% of the operating time with highest load (dead load + 1/1 payload) • 10% of the operating time with dead load only 	1	

7

One of the load spectrums listed above should be selected on the basis of the actual operating conditions and entered in the crane logbook for the respective testing interval.

The load spectrum L1 and the load spectrum factor Km = 0.125 are generally applied to your crane.

Determination of the effective operating hours Ti

The effective operating hours, must be entered into the crane log book for the corresponding testing interval.

Determining the proportion of theoretical service life used

For a testing interval "i" (max. 1 year according to ISO 9927-1) the used proportion of theoretical service life S_i is calculated using the formula :

$$S_i = \frac{K_{mi}}{K_m} \times T_i$$

K_m = Load spectrum factor established during winch calculation. This factor is given in the operating instructions.

K_{mi} = Load spectrum factor in inspection interval "i" in accordance with the section "Determining the operating conditions (collective load)"

T_i = Effective operating hours in the testing interval "i" according to section "Determining the actual operating hours T_i "

This used proportion is subtracted from the remaining theoretical service life D_i after every testing interval (see example in the appendix to this chapter).

If the remaining theoretical service life is not sufficient for the next operating period, then a general overhaul of the winch must be performed.

If theoretical service life D has been reached (7.14.1), the winch must not be operated until after a general overhaul has been performed.

A general overhaul must be performed at least once every 10 years after commissioning of the crane.

The general overhaul is to be arranged by the operator and performed by the manufacturer or their representative.

The results are to be entered in the crane logbook.

The manufacturer or his representative will specify a new theoretical service life D upon completion of the general overhaul.

The next general overhaul must be performed within 10 years.

Alternative provision

If, after ten years, the theoretical service life has not been used up, the winch can continue to be operated without a general overhaul under the following conditions.

The crane expert has confirmed that the used portion of the service life is correct and proper by signing his/her name in the crane test book after every inspection. In this case, the crane expert must closely inspect the winch.

As a minimum, this includes :

- A visual inspection of the exterior (for leaks, damage, malformation etc.)
- An oil inspection (especially for metallic residue)
- A load inspection with minimum and maximum rope pull and each with maximum possible speed.

At least one position is to be wound.

Pay attention to any unusual noises during the load inspection.

This inspection must be confirmed in the crane test book by the crane expert and there must be a declaration of continued operation for the winch.

The next inspection takes place before the 12th year of operation and must be repeated every year thereafter.

Sample table to determine the remaining theoretical service life on winch no. 1 (main hoisting winch)

Crane model : CK1200G
 Work number : GK05-****
 Commissioned on : 01.04.2011
 Serial number of the winch in accordance with the type plate :
 Last general overhaul performed on :
 Winch design data (see operating instructions) :
 Power unit group : M 3
 Load spectrum : Q 1 (L 1)
 Factor of the load spectrum : Km = 0.125
 Theoretical service life : D = 3,200 h

Inspection interval no. (max. 1 year)	Date of commission/ (date of inspection)	Operational condition since the last inspection	Load spectrum factor Km _h	Operating hours of the entire crane	Operating hours of the superstructure since the last inspection [h]	Operating hours of the winch	Operating hours of the winch since the last inspection [h]	Used proportion of theoretical service life D _i [h]	Remaining theoretical service life D _i = D _{1,1} - S _i [h]	Name of competent person	Signature	Note	Name of the approved inspector	Signature
"I"														
0(*)	10. 6. 11	-	-	-	0	-	-	0	3,200					
1	5. 6. 12	L 1	0.125	-	800	800	160 (20% of 800)	160	3,040					
2	20. 5. 13	L 2	0.5	-	2,000	1,200	480 (40% of 1,200)	1,920	1,120					
3	18. 5. 14	L 3	0.25	-	3,000	1,000	300 (30% of 1,000)	600	520					

CAUTION :
A general overhaul is to be performed every 10 years.

Alternative provision, refer to [ALTERNATIVE PROVISION] in chapter "10.11.2".

Last general overhaul performed on

- S_i = Used proportion of theoretical service life since the last inspection
- D_i = Remaining theoretical service life
- D_{1,1} = Remaining theoretical service life after the previous inspection
- Km = Load spectrum factor established during winch calculation. This factor is given in the operating instructions.
- Km_h = Load spectrum factor in the inspection interval "n".
- T_i = Effective working hours in the inspection interval "i".
- (*) Copy last line of the previous page to the following pages.

7.14.3 EXAMPLE

Power unit group	M3
Load spectrum	Light L1, Km = 0.125
Theoretical service life	D = 3,200 h

The used proportion S of theoretical service life is calculated over the individual inspection intervals as follows :

1. Inspection (1st year)

The crane was used for assembly work during the previous year : Load spectrum L1, i.e. Km1 = 0.125.

The operating hour counter reads 800 h.

The winch was operated 20 % of the time, i.e. T1 = 160 h.

The used proportion S1 of theoretical service life after the first inspection is therefore :

$$S_1 = \frac{0.125}{0.125} \times 160 \text{ h} = 160 \text{ h}$$

Remaining theoretical service life :

$$D_1 = 3,200 \text{ h} - 160 \text{ h} = 3,040 \text{ h}$$

The aforementioned values are entered in the table (see table example P.7-138.)

2. Inspection (2nd year)

The crane was used for unloading work on docks :

Load spectrum : L3, i.e. Km2 = 0.5.

The operating hour counter reads 2,000 h, i.e. during this period :

2,000 h - 800 h = 1,200 h (800 h were used during the first year).

The winch was operated 40 % of the time, i.e. T2 = 480 h.

The used proportion S2 of theoretical service life after the second inspection is therefore :

$$S_2 = \frac{0.5}{0.125} \times 480 \text{ h} = 1,920 \text{ h}$$

Remaining theoretical service life :

$$D_2 = 3,040 \text{ h} - 1,920 \text{ h} = 1,120 \text{ h}$$

The values above are entered in the table (see table example P.7-138.)

3. Inspection (3rd year)

The crane was used for assembly work and occasional unloading work on docks :

Load spectrum : L2, i.e. $Km3 = 0.25$.

The operating hour counter reads 3,000 h, i.e. during this period :

$3,000 \text{ h} - 2,000 \text{ h} = 1,000 \text{ h}$ (2,000 h were used during the first two years).

The winch was operated 30% of the time, i.e. $T3 = 300 \text{ h}$.

The used proportion S3 of theoretical service life after the third inspection interval is therefore :

$$Si = \frac{0.25}{0.125} \times 300 \text{ h} = 600 \text{ h}$$

Remaining theoretical service life :

$$D3 = 1,220 \text{ h} - 600 \text{ h} = 620 \text{ h}$$

The values are entered in the table (see table example P.7-138.)

8. REFERENCE MATERIALS

8.1	SPECIFICATION	8-1
8.1.1	OUTER DIMENSION	8-2
8.1.2	CRANE SPECIFICATION, PERFORMANCE.....	8-3
8.1.3	CRANE WORKING RANGES	8-4
8.2	DIMENSION, WEIGHT OF EACH COMPONENT	8-7
8.2.1	BASE MACHINE	8-7
8.2.2	COUNTERWEIGHT	8-9
8.2.3	ATTACHMENT	8-11
8.3	CLAMSHELL RATED LOADS (OPTION).....	8-14
8.4	SWING AND PROPEL STABILITY	8-17
8.5	PROPEL ALLOWABLE SLOPE ANGLE.....	8-19
8.5.1	CRANE ATTACHMENT INSTALLED : BOOM INSERT CONFIGURATION.....	8-19
8.6	LOW GANTRY POSITION	8-26
8.7	SAFETY DEVICE LIST (OPTION)	8-27

8. REFERENCE MATERIALS

Note

Actual lengths of boom section, wire rope are metric.

The values in () are approximate conversion to feet.

8.1 SPECIFICATION

This crane is designed for normal work of lifting hook.

Classification of this crane is as follows.

(ISO 4301/2, FEM 1.001)

Class of utilization : U1

State of loading : Q2

Group Classification as crane : A1

In case of severer work condition such as bucket etc, components life may be lowered.

In case of severer work condition, perform work referring to manufacture's recommended condition.

As for Front or Rear winch, calculate service life of component referring to article 7. "MEASURES REQUIRED FOR WINCH MONITORING" and perform maintenance work under appropriate interval.

8.1.1 OUTER DIMENSION

Unit : mm (ft. in.)

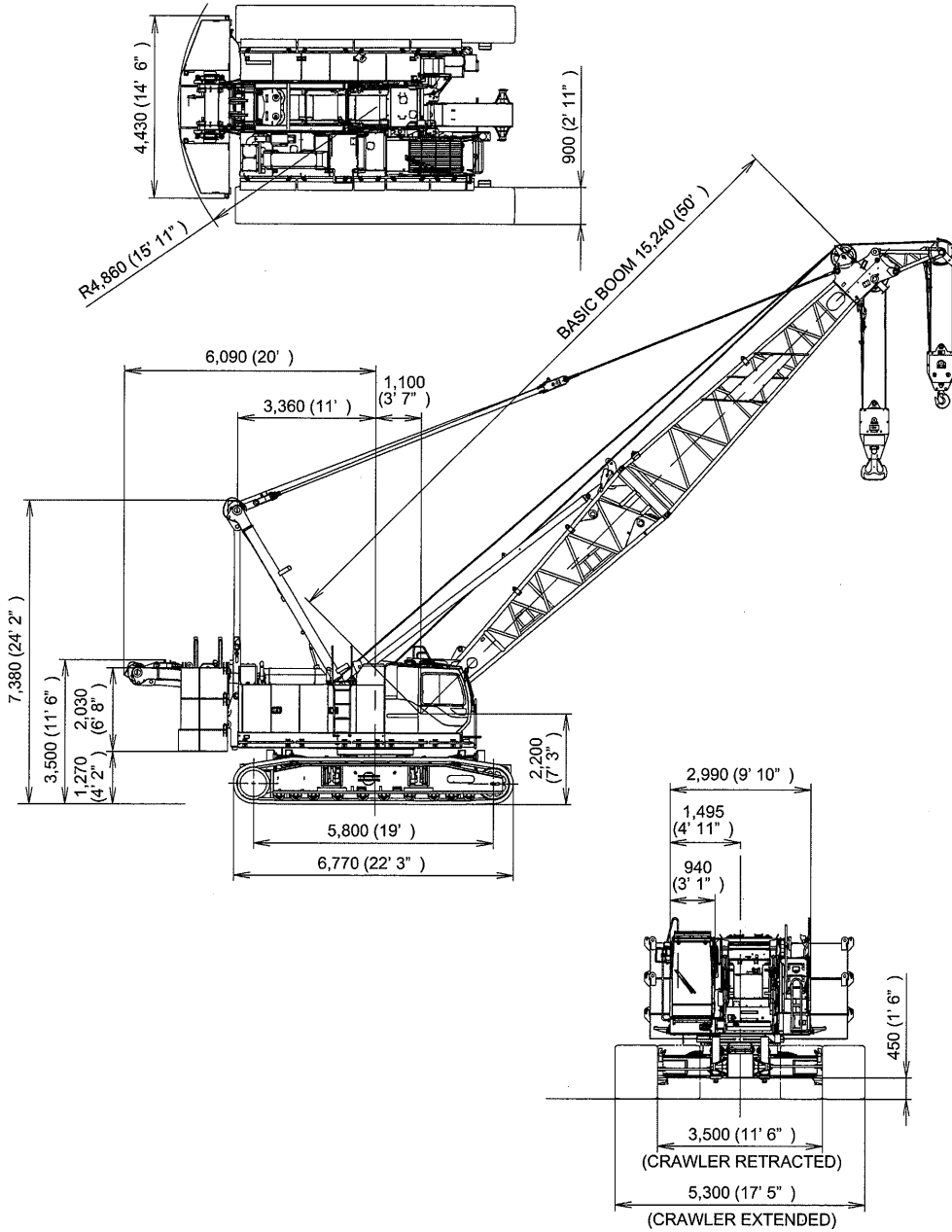

8.1.2 CRANE SPECIFICATION, PERFORMANCE

Type	Full swing, crawler type	
Max. rated load × work radius	108.9 t × 3.65 m (240,000 lbs × 12')	
Boom length		
• Basic boom	15.2 m (50')	
• Maximum boom	70.1 m (230')	
• Crane jib	9.1 m (30') to 21.3 m (70')	
• Maximum boom and jib	61 m (200') Boom + 21.3 m (70') Jib	
Work speed (wire rope)		Wire rope dia.
• Front / Rear hoisting rope speed	120 m/min (390 ft/min)	26 mm
• Front / Rear lowering rope speed	120 m/min (390 ft/min)	
• Boom raising rope speed	48 m/min (160 ft/min)	20 mm
• Boom lowering rope speed	48 m/min (160 ft/min)	
• Third hoisting rope speed (option)	120 m/min (390 ft/min)	26 mm
• Third lowering rope speed (option)	120 m/min (390 ft/min)	
• Swing speed	3.2 min ⁻¹ (3.2 rpm)	
• Propel speed	1.4/1.0 km/h (0.87/0.62 MPH)	
Grad ability (tan θ)	40%	
Working weight *1	99.942 t (220,330 lbs)	
Average ground pressure *1	Approx. 93.9 kPa (13.6 psi)	
Engine		
• Engine name	Hino J08E-UV	
• Engine out put	213 kW/2,100 min ⁻¹ (286 HP/2,100 rpm)	

*1 Crane (15.2 m [50'], Without rear drum rope, Without main hook, With self removal)

- Each rope speed varies based on load.
- Each rope speed is the value of the drum first layer's one.

OUTSIDE DIMENSIONS

Unit : mm (ft. in.)

Overall width of cab	2,990 (9' 10")
Radius of rear end (counterweight)	4,860 (15' 11")
Center of rotation to rear end (low gantry position)	6,090 (20')
Center of rotation to boom foot pin (from center of rotation)	1,100 (3' 7")
Height from ground to boom foot pin	2,200 (7' 3")
Height to top of gantry (working position)	7,380 (24' 2")
Height to top of gantry (low gantry position)	3,500 (11' 6")
Counterweight ground clearance	1,270 (4' 2")
Overall length of crawlers	6,770 (22' 3")
Distance between centers of tumblers	5,800 (19')
Overall width of crawlers (extend/retract)	5,300 / 3,500 (17' 5" / 11' 6")
Width of crawler shoe	900 (2' 11")
Ground clearance of carbody	450 (1' 6")

8.1.3 CRANE WORKING RANGES

1. Crane working ranges

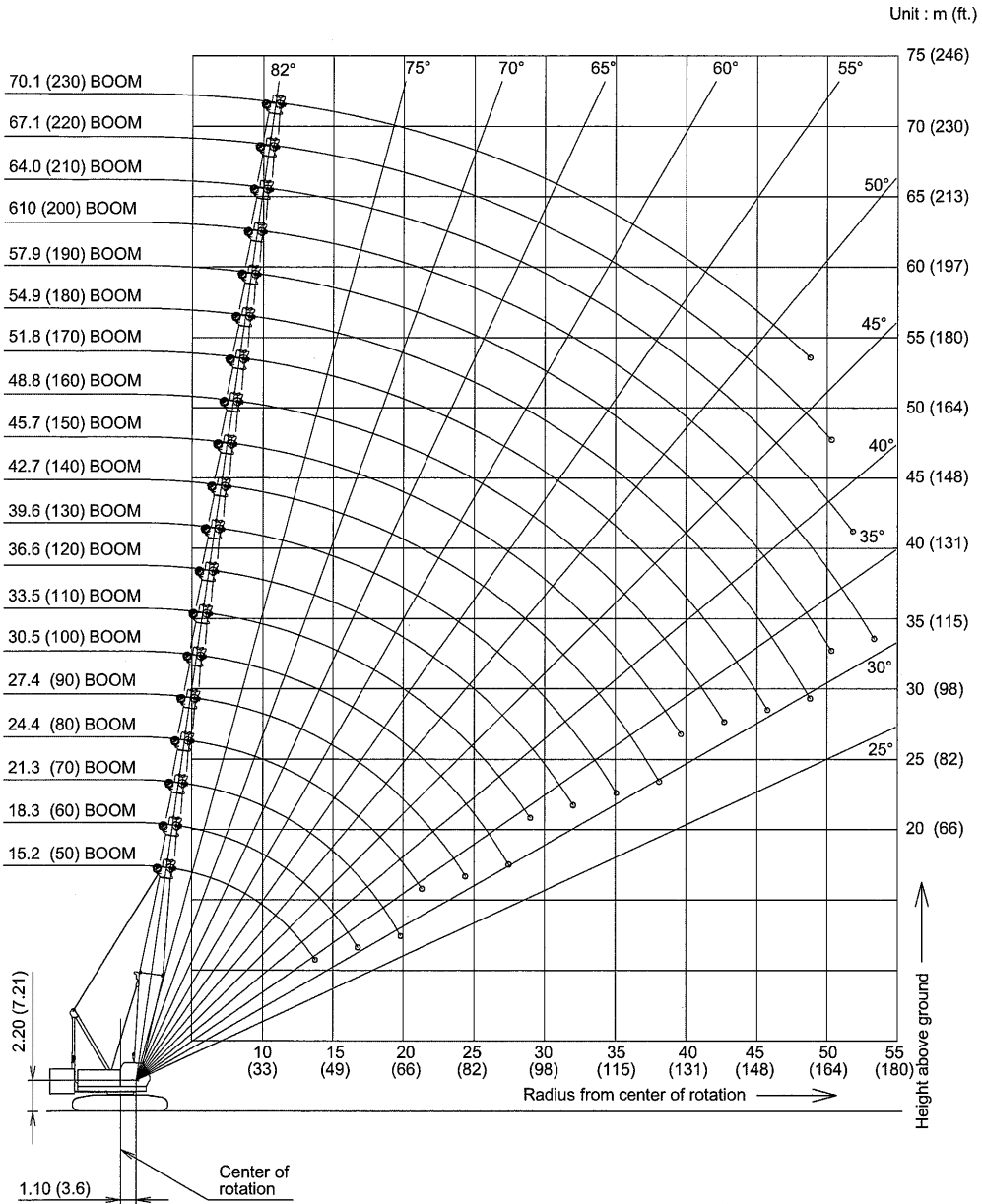

2. Jib working range

(1) Offset angle 10 degrees

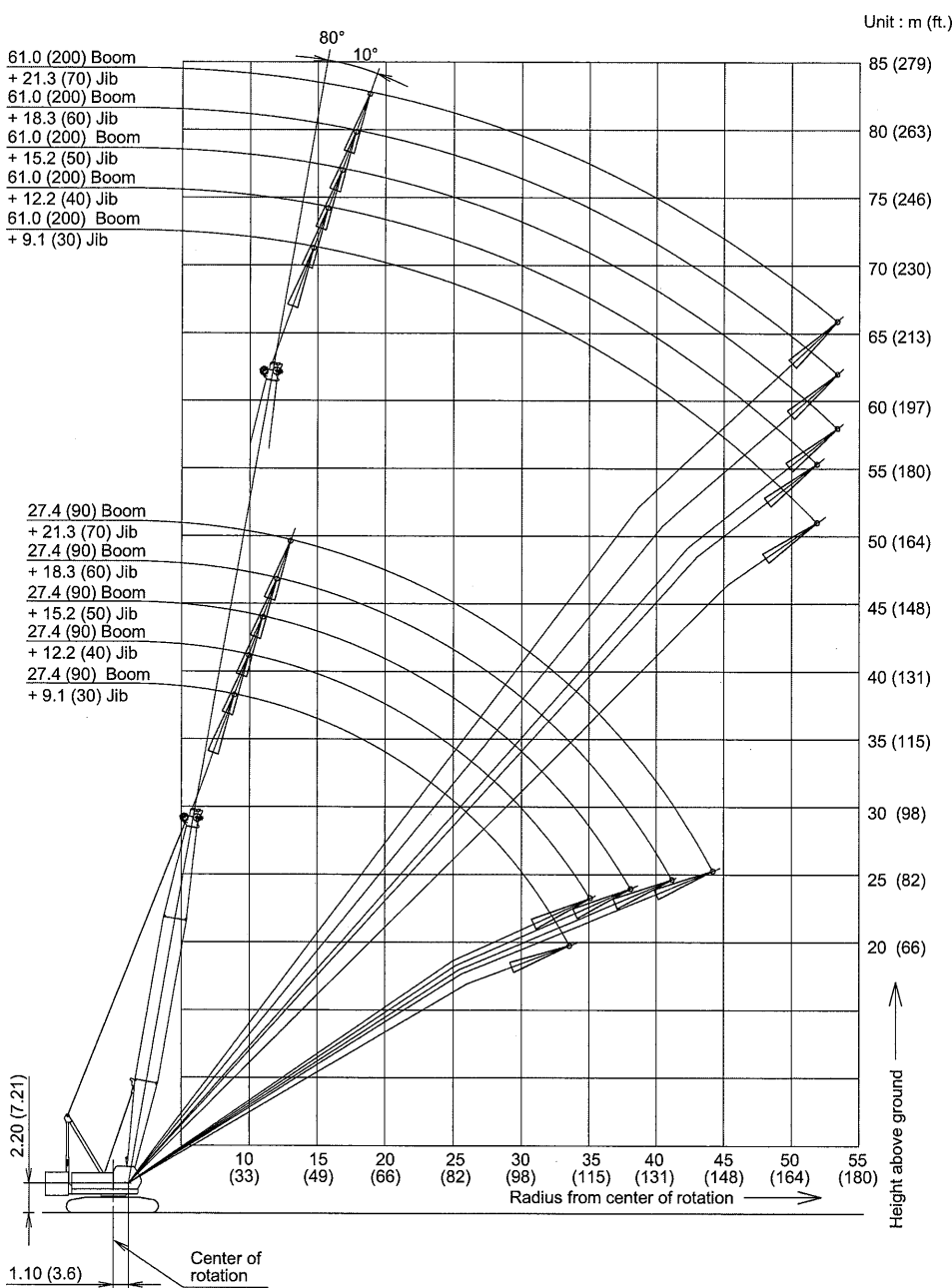

(2) Offset angle 30 degrees

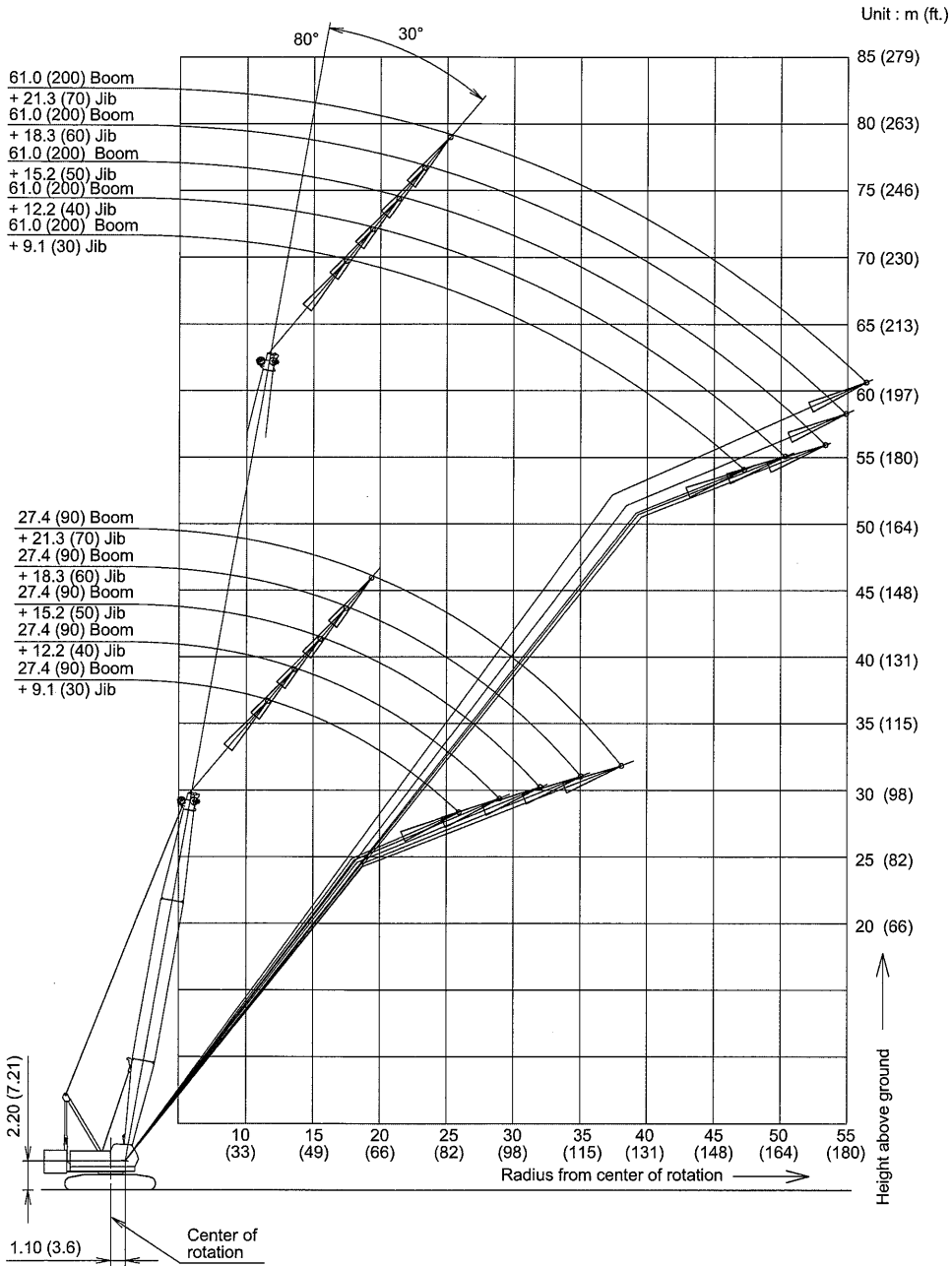

8.2 DIMENSION, WEIGHT OF EACH COMPONENT

Dimension and weight of each component when disassembled is shown here.
Use this as reference value.

8.2.1 BASE MACHINE

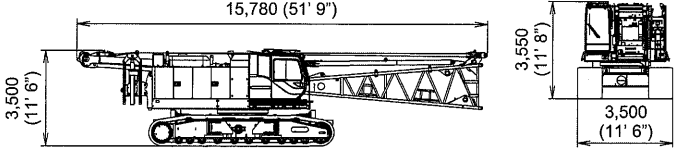
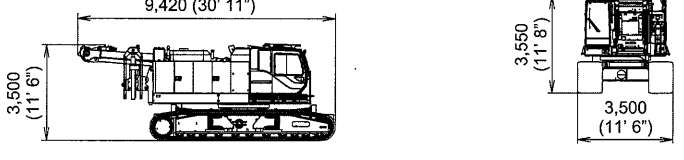
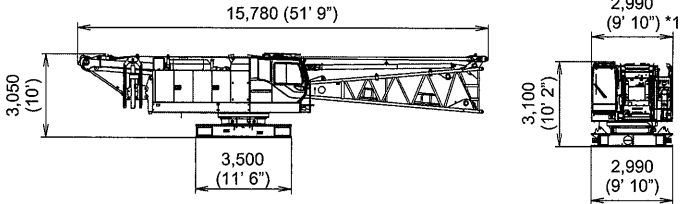
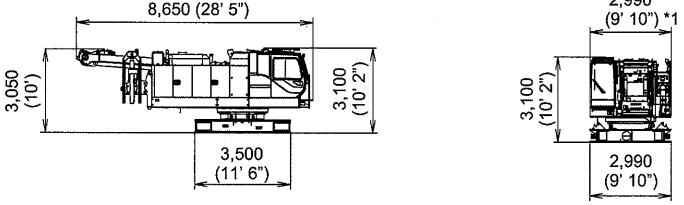
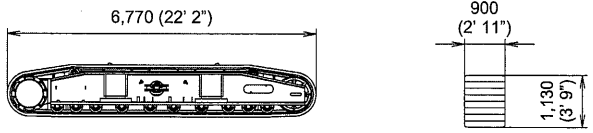
Name	Dimension : mm (ft. in.)	Weight : kg (lbs)
Base Machine <ul style="list-style-type: none"> • Boom base • Gantry • Crawler • Wire rope (Front, rear, boom hoist) 		57,520 (126,808)
Base Machine <ul style="list-style-type: none"> • Gantry • Crawler • Wire rope (Front, rear, boom hoist) 		54,200 (119,489)
Base Machine <ul style="list-style-type: none"> • Boom base • Gantry • Wire rope (Front, rear, boom hoist) • Without crawler • Without side steps 		33,660 (74,206)
Base Machine <ul style="list-style-type: none"> • Gantry • Wire rope (Front, rear, boom hoist) • Without crawler • Without side steps 		30,340 (66,887)
Crawler		11,930 (26,301)

*1 With the side step on cabin side : 3,170 (10' 5")
With the side steps on the both side : 3,340 (11')

Name	Dimension : mm (ft. in.)	Weight : kg (lbs)
Translifter	<p>Technical drawing of a Translifter component. The drawing shows two views: a side view and a top view. The side view shows a triangular structure with a central spring mechanism. Dimensions include a height of 970 mm (3' 2") and a base width of 1,480 mm (4' 10"). The top view shows a rectangular base with a width of 1,480 mm (4' 10") and a height of 230 mm (9").</p>	320 (705) /1piece

8.2.2 COUNTERWEIGHT

Name	Dimension : mm (ft. in.)	Weight : kg (lbs)
No.1 Counterweight	<p>Technical drawing of counterweight No.1. The top view shows a rectangular shape with a width of 4,430 mm (14' 6") and a height of 1,190 mm (3' 11"). The side view shows a depth of 830 mm (2' 9").</p>	11,600 (25,600)
No.3, No.5 Counterweight (R)	<p>Technical drawing of counterweight No.3, No.5 (Right). The drawing shows two views. The top view has a width of 880 mm (2' 11") and a length of 1,450 mm (4' 9"). The side view has a height of 1,170 mm (3' 10").</p>	5,750 (12,680)
No.2, No.4 Counterweight (L)	<p>Technical drawing of counterweight No.2, No.4 (Left). The drawing shows two views. The top view has a length of 1,450 mm (4' 9") and a width of 880 mm (2' 11"). The side view has a height of 1,170 mm (3' 10").</p>	5,750 (12,680)

[8. REFERENCE MATERIALS]

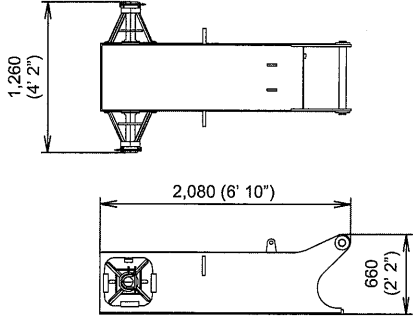
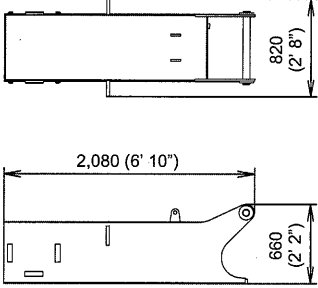
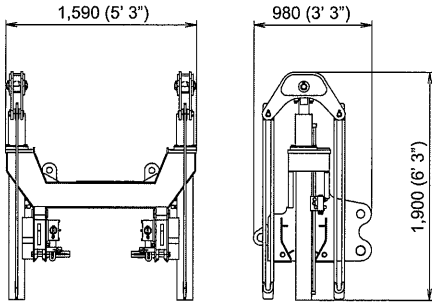
Name	Dimension : mm (ft. in.)	Weight : kg (lbs)
<p>Carbody weight</p> <ul style="list-style-type: none"> • With float 		<p>3,320 (7,319) /1piece</p>
<p>Carbody weight</p> <ul style="list-style-type: none"> • Without float 		<p>3,250 (7,165) /1piece</p>
<p>Self removal unit</p>		<p>870 (1,918)</p>

8.2.3 ATTACHMENT

Name	Dimension : mm (ft. in.)	Weight : kg (lbs)
Boom tip		1,525 (3,360)
Boom base		2,235 (4,927)
3.0 m (10') Boom insert		380 (840)
6.1 m (20') Boom insert		655 (1,445)
12.2 m (40') Boom insert		1,195 (2,635)
12.2 m (40') Boom insert (With lug)		1,220 (2,690)
Backstop		440 (970) (each)

8

[8. REFERENCE MATERIALS]

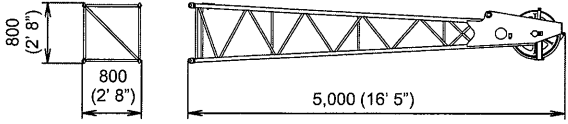
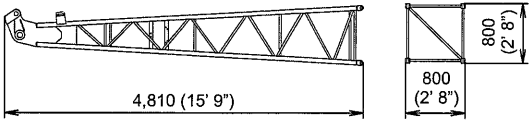
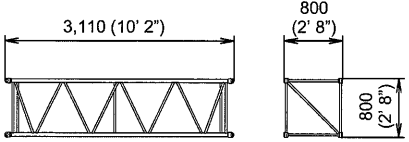
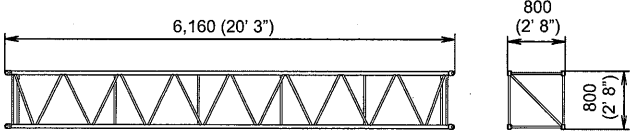
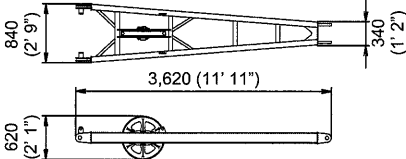
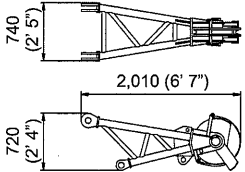
Name	Dimension : mm (ft. in.)	Weight : kg (lbs)
Jib tip		280 (620)
Jib base		200 (440)
3.0 m (10') Jib insert		100 (220)
6.0 m (20') Jib insert		180 (400)
strut		250 (550)
Auxiliary sheave		300 (660)

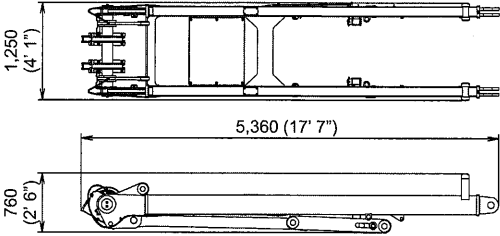
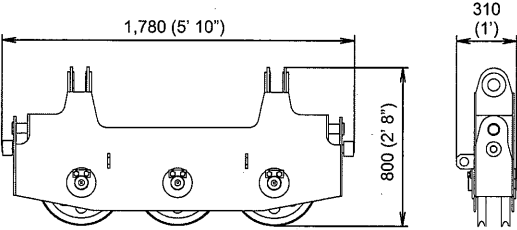
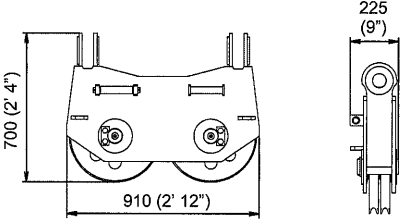
Name	Dimension : mm (ft. in.)	Weight : kg (lbs)
Gantry		1,320 (2,910)
Upper spreader		300 (660)
Lower spreader		200 (440)

8.3 CLAMSHELL RATED LOADS (OPTION)

CLAMSHELL SPECIFICATION

1. Rated loads included in the charts are the maximum allowable freely suspended loads at a given boom length, boom angle and load radius, and have been determined for the machine standing level on firm supporting surface under ideal operating conditions.

The user must limit or de-rate rated loads to allow for adverse conditions (such as soft or uneven ground, out-of-level conditions, wind, side loads, pendulum action, jerking or sudden stopping of loads, inexperience of personnel, multiple machine lifts, and traveling with a load).

2. Rated loads do not exceed 66% of minimum tipping loads.

Rated loads based on factors other than machine stability such as structural competence are shown by asterisk * in the charts.

3. The machine must be reeved and set-up as stated in the operation manual and all the instruction manuals.

If these manuals are missing, obtain replacements.

- Boom backstops are required for all boom lengths.
- Gantry must be fully raised position for all operations.
- Crawlers must be fully extended and be locked in position.
- The crane must be leveled to within 1% on a firm supporting surface.
- 50,900 lbs Counterweight and without carbody weight.

4. Do not attempt to lift where no radius on load is listed as crane may tip or collapse.

5. Attempting to lift more than rated loads may cause machine to tip or collapse.

Do not tip machine to determine rated loads.

6. Weight of bucket, slings and other lifting devices are a part of the total load.

Their total weight must be subtracted from the rated load to obtain the weight that can be lifted.

7. The boom should be erected over the front of the crawlers, not laterally.
8. Least stable position is over the side.

MAXIMUM LOAD FOR MAIN BOOM

No. of Part of Line	1
Maximum Loads (lbs)	25,000

9. Rated loads listed apply only to the machine as originally manufactured and designed by KOBELCO CRANES CO.,LTD. Modifications to this machine or use of equipment other than that specified can reduce operating capacity.

10. Assembling the counterweight

- 50,900 lbs Counterweight
- Without carbody counterweight.

Operation of this equipment in excess of rated loads or disregard of instruction voids the warranty.

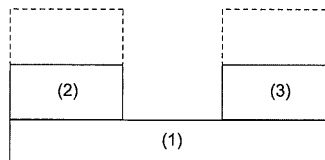

COUNTERWEIGHTS



CARBODY WEIGHTS

CLAMSHELL CAPACITIES IN POUNDS
 THREE COUNTERWEIGHTS (50,900 lbs)
 WITHOUT CARBODY WEIGHTS (0 lbs)
 CRAWLERS : EXTENDED POSITION

50' Boom		
Load Radius (ft.)	Boom Angle (deg.)	360° Rated Load (lbs)
26.0	64.4	25,000 *
28.0	61.8	25,000 *
30.0	59.2	25,000 *
32.0	56.4	25,000 *
34.0	53.6	25,000 *
36.0	50.7	25,000 *
38.0	47.6	25,000 *
40.0	44.3	25,000 *
45.0	35.2	23,100

60' Boom		
Load Radius (ft.)	Boom Angle (deg.)	360° Rated Load (lbs)
30.0	64.8	25,000 *
32.0	62.6	25,000 *
34.0	60.4	25,000 *
36.0	58.2	25,000 *
38.0	55.9	25,000 *
40.0	53.5	25,000 *
45.0	47.2	22,900
50.0	40.2	19,800
55.0	31.9	17,400

70' Boom		
Load Radius (ft.)	Boom Angle (deg.)	360° Rated Load (lbs)
34.0	65.0	25,000 *
36.0	63.2	25,000 *
38.0	61.3	25,000 *
40.0	59.4	25,000 *
45.0	54.5	22,700
50.0	49.2	19,600
55.0	43.5	17,200
60.0	37.1	15,200

80' Boom		
Load Radius (ft.)	Boom Angle (deg.)	360° Rated Load (lbs)
40.0	63.6	25,000 *
45.0	59.5	22,500
50.0	55.2	19,400
55.0	50.7	17,000
60.0	45.8	15,000
65.0	40.5	13,200
70.0	34.6	11,900

90' Boom		
Load Radius (ft.)	Boom Angle (deg.)	360° Rated Load (lbs)
45.0	63.2	21,600 *
50.0	59.5	19,200
55.0	55.8	16,800
60.0	51.8	14,800
65.0	47.6	13,000
70.0	43.0	11,700
75.0	38.1	10,600
80.0	32.5	9,500

100' Boom		
Load Radius (ft.)	Boom Angle (deg.)	360° Rated Load (lbs)
50.0	62.9	18,500 *
55.0	59.6	16,500
60.0	56.2	14,600
65.0	52.6	12,800
70.0	48.9	11,500
75.0	45.0	10,400
80.0	40.7	9,300
85.0	36.0	8,400
90.0	30.8	7,700

110' Boom		
Load Radius (ft.)	Boom Angle (deg.)	360° Rated Load (lbs)
55.0	62.6	15,900 *
60.0	59.6	14,300
65.0	56.5	12,600
70.0	53.3	11,200
75.0	50.0	9,900
80.0	46.5	9,000
85.0	42.7	8,200
90.0	38.7	7,300
95.0	34.3	6,600

120' Boom		
Load Radius (ft.)	Boom Angle (deg.)	360° Rated Load (lbs)
60.0	62.4	13,900 *
65.0	59.7	12,600
70.0	56.8	11,200
75.0	53.9	9,900
80.0	50.9	9,000
85.0	47.7	8,200
90.0	44.4	7,300
95.0	40.8	6,600
100.0	37.0	6,000
105.0	32.8	5,500

8.4 SWING AND PROPEL STABILITY

1. Without carbody weight

Attachment	Counterweight : t (lbs)	All-round swing			Propelling on slope	
		Crawler extend	Crawler retract	When jacked up without crawler	Forward	Backward
Without attachment (Base machine only)	0 (Without)	○	○	○	○	○
	11.6 (25,573) (No.1)	○	△ (No abrupt lever control)	×	○	○
	23.1 (50,925) (No.1 to No.2)	○	×	×	×	○
	34.6 (76,277) (No.1 to No.3)	×	×	×	×	×
With boom base (Boom angle : 30 degrees or less)	0 (Without)	○	○	○	○	○
	11.6 (25,573) (No.1)	○	○	×	○	○
	23.1 (50,925) (No.1 to No.2)	○	×	×	△ (Slope : 8 deg. or less)	○
	34.6 (76,277) (No.1 to No.3)	△ (No abrupt lever control)	×	×	×	△ (No abrupt lever control)

8

○ : Allowed
 △ : With restriction
 × : Not allowed

(1) The table above shows the values for operation on a firm ground.

On a weak ground, operate with care after curing the ground.

(2) As a principle, swinging on a trailer is prohibited.

(3) Maximum slope angle is 21.8 degrees (40%). This may become lower depending on condition (ground, crane configuration).

(4) Travelling forward means the case where the counterweight is at the lower slope and the traveling backward where it is at the upper slope.

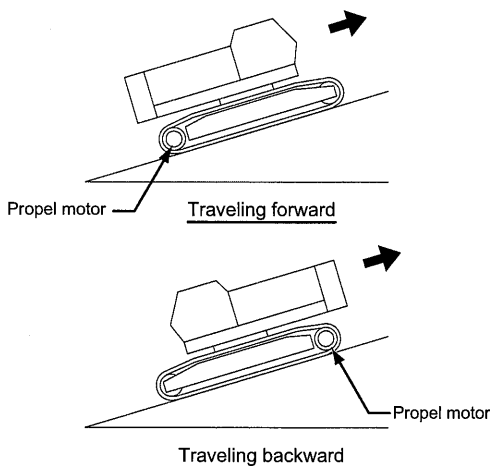

2. With carbody weight

Attachment	Counterweight : t (lbs)	All-round swing			Propelling on slope	
		Crawler extend	Crawler retract	When jacked up without crawler	Forward	Backward
Without attachment (Base machine only)	0 (Without)	○	○	○	○	○
	11.6 (25,573) (No.1)	○	○	×	○	○
	23.1 (50,925) (No.1 to No.2)	○	×	×	△ (Slope : 5 deg. or less)	○
	34.6 (76,277) (No.1 to No.3)	△ (No abrupt lever control)	×	×	×	△ (No abrupt lever control)
With boom Base (Boom angle : 30 degrees or less)	0 (Without)	○	○	○	○	○
	11.6 (25,573) (No.1)	○	○	△ (No abrupt lever control)	○	○
	23.1 (50,925) (No.1 to No.2)	○	×	×	△ (Slope : 12 deg. or less)	○
	34.6 (76,277) (No.1 to No.3)	○	×	×	×	○

○ : Allowed
 △ : With restriction
 × : Not allowed

- (1) The table above shows the values for operation on a firm ground.
 On a weak ground, operate with care after curing the ground.
- (2) As a principle, swinging on a trailer is prohibited.
- (3) Maximum slope angle is 21.8 degrees (40%).
 This may become lower depending on condition (ground, crane configuration).
- (4) Travelling forward means the case where the counterweight is at the lower slope and the traveling backward where it is at the upper slope.

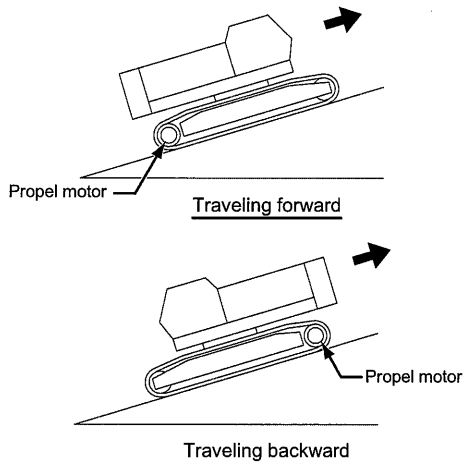

8.5 PROPEL ALLOWABLE SLOPE ANGLE

8.5.1 CRANE ATTACHMENT INSTALLED : BOOM INSERT CONFIGURATION

CAUTION

In the area showing [-] mark, do not propel.

Machine may overturn.

Failure to observe this precaution may result in a serious injuries or loss of life.

If the machine has to propel by some reason, observe the following points.

- Do not propel with a load lifted.
- Propel with low speed and gently.
- Propel on the flat and firm ground.
- Ensure to check the ground condition and propel on the slope angle smaller than shown in the chart.
- Propel straight against slope.
- Provide the gentle slope at the beginning and end positions of slope.

8

PROPEL UPWARD DOWNWARD ON SLOPE (θ : ALLOWABLE ANGLE)

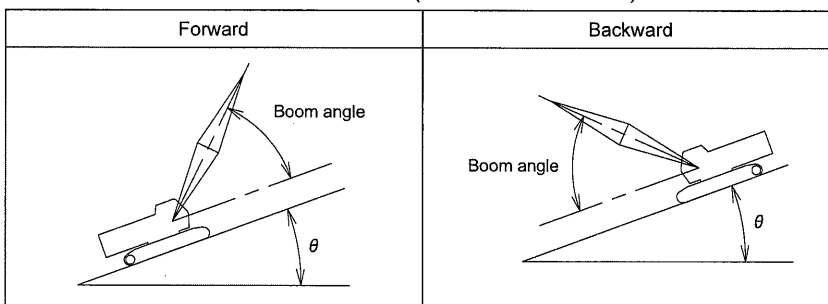

1. Crane propel allowable slope angle

(1) Without Aux. sheave

(Unit : Degrees)

Boom length m (ft.)	Forward			Backward		
	Boom angle			Boom angle		
	35	40	50	40	50	60
15.2 (50)	7	7	5	8	8	8
18.3 (60)	8	8	6	8	8	8
21.3 (70)	8	8	7	8	8	8
24.4 (80)	8	8	7	8	8	8
27.4 (90)	8	8	7	8	8	8
30.5 (100)	8	8	8	8	8	8
33.5 (110)	8	8	8	8	8	8
36.6 (120)	8	8	8	8	8	8
39.6 (130)	8	8	8	8	8	8
42.7 (140)	8	8	8	8	8	8
45.7 (150)	8	8	8	8	8	8
48.8 (160)	8	8	8	7	8	8
51.8 (170)	8	8	8	5	6	8
54.9 (180)	8	8	8	3	5	6
57.9 (190)	8	8	8	1	3	5
61.0 (200)	8	8	8	-	2	4
64.0 (210)	8	8	8	-	-	2
67.1 (220)	8	8	8	-	-	1
70.1 (230)	8	8	8	-	-	-

(2) With Aux. sheave

(Unit : Degrees)

Boom length m (ft.)	Forward			Backward		
	Boom angle			Boom angle		
	35	40	50	40	50	60
15.2 (50)	7	7	5	8	8	8
18.3 (60)	8	8	6	8	8	8
21.3 (70)	8	8	7	8	8	8
24.4 (80)	8	8	7	8	8	8
27.4 (90)	8	8	7	8	8	8
30.5 (100)	8	8	8	8	8	8
33.5 (110)	8	8	8	8	8	8
36.6 (120)	8	8	8	8	8	8
39.6 (130)	8	8	8	8	8	8
42.7 (140)	8	8	8	8	8	8
45.7 (150)	8	8	8	8	8	8
48.8 (160)	8	8	8	7	8	8
51.8 (170)	8	8	8	5	6	8
54.9 (180)	8	8	8	3	5	6
57.9 (190)	8	8	8	1	3	5
61.0 (200)	8	8	8	-	2	4
64.0 (210)	8	8	8	-	-	2
67.1 (220)	8	8	8	-	-	1

2. Fixed jib propel allow slope angle

(Unit : Degrees)

Jib length m (ft.)	9.1 (30)					
Offset angle	10					
Configuration	Forward			Backward		
Boom length m (ft.)	Boom angle			Boom angle		
	35	40	50	40	50	60
27.4 (90)	8	8	8	8	8	8
30.5 (100)	8	8	8	8	8	8
33.5 (110)	8	8	8	8	8	8
36.6 (120)	8	8	8	8	8	8
39.6 (130)	8	8	8	8	8	8
42.7 (140)	8	8	8	7	8	8
45.7 (150)	8	8	8	5	6	8
48.8 (160)	8	8	8	4	5	7
51.8 (170)	8	8	8	2	4	5
54.9 (180)	8	8	8	-	2	4
57.9 (190)	8	8	8	-	-	3
61.0 (200)	8	8	8	-	-	1

(Unit : Degrees)

Jib length m (ft.)	9.1 (30)					
Offset angle	30					
Configuration	Forward			Backward		
Boom length m (ft.)	Boom angle			Boom angle		
	35	40	50	40	50	60
27.4 (90)	8	8	8	8	8	8
30.5 (100)	8	8	8	8	8	8
33.5 (110)	8	8	8	8	8	8
36.6 (120)	8	8	8	8	8	8
39.6 (130)	8	8	8	8	8	8
42.7 (140)	8	8	8	7	8	8
45.7 (150)	8	8	8	5	6	8
48.8 (160)	8	8	8	4	5	7
51.8 (170)	8	8	8	2	4	5
54.9 (180)	8	8	8	-	2	4
57.9 (190)	8	8	8	-	-	3
61.0 (200)	8	8	8	-	-	1

8

(Unit : Degrees)

Jib length m (ft.)	12.2 (40)					
Offset angle	10					
Configuration	Forward			Backward		
Boom length m (ft.)	Boom angle			Boom angle		
	35	40	50	40	50	60
27.4 (90)	8	8	8	8	8	8
30.5 (100)	8	8	8	8	8	8
33.5 (110)	8	8	8	8	8	8
36.6 (120)	8	8	8	8	8	8
39.6 (130)	8	8	8	8	8	8
42.7 (140)	8	8	8	7	7	8
45.7 (150)	8	8	8	4	6	7
48.8 (160)	8	8	8	3	5	6
51.8 (170)	8	8	8	1	3	5
54.9 (180)	8	8	8	-	1	4
57.9 (190)	8	8	8	-	-	2
61.0 (200)	8	8	8	-	-	1

(Unit : Degrees)

Jib length m (ft.)	12.2 (40)					
Offset angle	30					
Configuration	Forward			Backward		
Boom length m (ft.)	Boom angle			Boom angle		
	35	40	50	40	50	60
27.4 (90)	8	8	8	8	8	8
30.5 (100)	8	8	8	8	8	8
33.5 (110)	8	8	8	8	8	8
36.6 (120)	8	8	8	8	8	8
39.6 (130)	8	8	8	8	8	8
42.7 (140)	8	8	8	7	7	8
45.7 (150)	8	8	8	4	6	7
48.8 (160)	8	8	8	3	5	6
51.8 (170)	8	8	8	1	3	5
54.9 (180)	8	8	8	-	1	3
57.9 (190)	8	8	8	-	-	2
61.0 (200)	8	8	8	-	-	1

(Unit : Degrees)

Jib length m (ft.)	15.2 (50)					
Offset angle	10					
Configuration	Forward			Backward		
Boom length m (ft.)	Boom angle			Boom angle		
	35	40	50	40	50	60
27.4 (90)	8	8	8	8	8	8
30.5 (100)	8	8	8	8	8	8
33.5 (110)	8	8	8	8	8	8
36.6 (120)	8	8	8	8	8	8
39.6 (130)	8	8	8	8	8	8
42.7 (140)	8	8	8	6	7	8
45.7 (150)	8	8	8	4	5	7
48.8 (160)	8	8	8	3	4	6
51.8 (170)	8	8	8	1	3	5
54.9 (180)	8	8	8	-	1	3
57.9 (190)	8	8	8	-	-	2
61.0 (200)	8	8	8	-	-	1

(Unit : Degrees)

Jib length m (ft.)	15.2 (50)					
Offset angle	30					
Configuration	Forward			Backward		
Boom length m (ft.)	Boom angle			Boom angle		
	35	40	50	40	50	60
27.4 (90)	8	8	8	8	8	8
30.5 (100)	8	8	8	8	8	8
33.5 (110)	8	8	8	8	8	8
36.6 (120)	8	8	8	8	8	8
39.6 (130)	8	8	8	8	8	8
42.7 (140)	8	8	8	6	7	8
45.7 (150)	8	8	8	4	5	7
48.8 (160)	8	8	8	3	4	6
51.8 (170)	8	8	8	1	2	4
54.9 (180)	8	8	8	-	1	3
57.9 (190)	8	8	8	-	-	2
61.0 (200)	8	8	8	-	-	1

(Unit : Degrees)

Jib length m (ft.)	18.3 (60)					
Offset angle	10					
Configuration	Forward			Backward		
Boom length m (ft.)	Boom angle			Boom angle		
	35	40	50	40	50	60
27.4 (90)	8	8	8	8	8	8
30.5 (100)	8	8	8	8	8	8
33.5 (110)	8	8	8	8	8	8
36.6 (120)	8	8	8	8	8	8
39.6 (130)	8	8	8	7	8	8
42.7 (140)	8	8	8	5	6	8
45.7 (150)	8	8	8	3	4	6
48.8 (160)	8	8	8	2	4	6
51.8 (170)	8	8	8	-	2	4
54.9 (180)	8	8	8	-	-	3
57.9 (190)	8	8	8	-	-	1
61.0 (200)	8	8	8	-	-	-

(Unit : Degrees)

Jib length m (ft.)	18.3 (60)					
Offset angle	30					
Configuration	Forward			Backward		
Boom length m (ft.)	Boom angle			Boom angle		
	35	40	50	40	50	60
27.4 (90)	8	8	8	8	8	8
30.5 (100)	8	8	8	8	8	8
33.5 (110)	8	8	8	8	8	8
36.6 (120)	8	8	8	8	8	8
39.6 (130)	8	8	8	7	8	8
42.7 (140)	8	8	8	5	6	8
45.7 (150)	8	8	8	3	4	6
48.8 (160)	8	8	8	2	4	5
51.8 (170)	8	8	8	-	2	4
54.9 (180)	8	8	8	-	-	3
57.9 (190)	8	8	8	-	-	1
61.0 (200)	8	8	8	-	-	-

(Unit : Degrees)

Jib length m (ft)	21.3 (70)					
Offset angle	10					
Configuration	Forward			Backward		
Boom length m (ft)	Boom angle			Boom angle		
	35	40	50	40	50	60
27.4 (90)	8	8	8	8	8	8
30.5 (100)	8	8	8	8	8	8
33.5 (110)	8	8	8	8	8	8
36.6 (120)	8	8	8	8	8	8
39.6 (130)	8	8	8	7	7	8
42.7 (140)	8	8	8	5	6	7
45.7 (150)	8	8	8	2	4	6
48.8 (160)	8	8	8	1	3	5
51.8 (170)	8	8	8	-	1	3
54.9 (180)	8	8	8	-	-	2
57.9 (190)	8	8	8	-	-	1
61.0 (200)	8	8	8	-	-	-

(Unit : Degrees)

Jib length m (ft)	21.3 (70)					
Offset angle	30					
Configuration	Forward			Backward		
Boom length m (ft)	Boom angle			Boom angle		
	35	40	50	40	50	60
27.4 (90)	8	8	8	8	8	8
30.5 (100)	8	8	8	8	8	8
33.5 (110)	8	8	8	8	8	8
36.6 (120)	8	8	8	8	8	8
39.6 (130)	8	8	8	7	7	8
42.7 (140)	8	8	8	5	6	7
45.7 (150)	8	8	8	2	4	6
48.8 (160)	8	8	8	1	3	5
51.8 (170)	8	8	8	-	1	3
54.9 (180)	8	8	8	-	-	2
57.9 (190)	8	8	8	-	-	1
61.0 (200)	8	8	8	-	-	-

8.6 LOW GANTRY POSITION

During the work, if the machine must propel under low overhead place such as under bridge, move with low gantry position (Gantry is lowered).

DANGER

Never lift a load with low gantry position. Otherwise damage to the boom, gantry or travel kit or coming up of counterweight may occur and is very dangerous.

Ensure to see that there is enough clearance between the machine height / boom height and the low overhead place.

Make low gantry propel distance as short as possible and slowly.

CONDITIONS

- The crawlers are fully extended.
- All counterweight are equipped and secured firmly with bolts.
- Install the travel kit to the counterweight firmly.
- Propel on level ground with low speed.
- The boom angle is horizontal or slightly up.
- Guy cable with proper length is connected on the boom tip.
- Boom angle should be such that the guy cables do not press down the boom tip guide roller.
- The longest boom length is 15.2 m (50 ft.)
(The longest boom length with auxiliary sheave is 15.2 m [50 ft.])

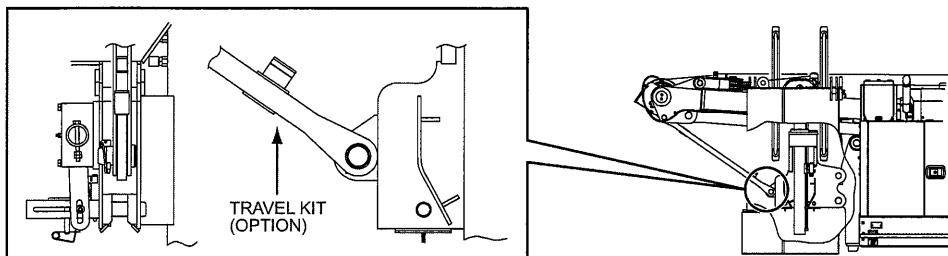
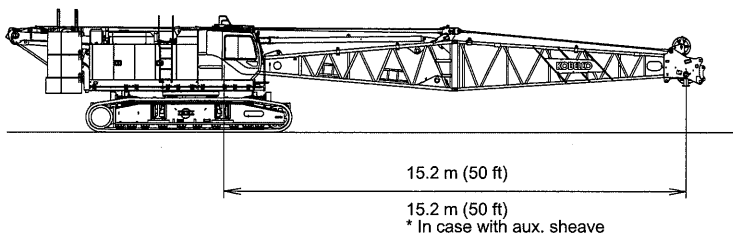

8.7 SAFETY DEVICE LIST (OPTION)

Item	Assembly dwg No.	
1. MONITOR CAMERA Monitor camera installation for rope winding and machine rear condition.	Front / rear drum monitor camera	GG55E00034F1
	Boom drum monitor camera	GG55E00031F1
	Machine rear monitor camera	GG55E00033F1
	Controller installation.	GG22E00042F2
2. CAB CEILING WINDOW GUARD Preventing damage of ceiling window by falling thing.	GG25C00009F1	
3. AUXILIARY PLATFORM Stowing type step on the both side of machine deck. (width : 300 mm)	Width : 300 mm (1')	GG40C00045F1
4. LOAD SAFETY DEVICE OUTER INDICATING LIGHT Indication of load condition by square type 3 color light to outside (gr, ye, Re)	GG53E00022F1	
5. PROPEL WARNING DEVICE Warning at propel by buzzer intermittent sound.	GG53E00019F1	
6. EXTINGUISHER ABC powder type extinguisher	For EU	GG71M00002F1
		GG71M00005F1
7. RIGHT AND LEFT GUARD UPPER FACE HANDRAIL (HIGH) Preventing falling off at guard upper face (folding type).	For right guard	GG41C00164F1
	For left guard	GG41C00170F1

9. ELECTRIC SYSTEM SCHEMATIC

9. ELECTRIC SYSTEM SCHEMATIC

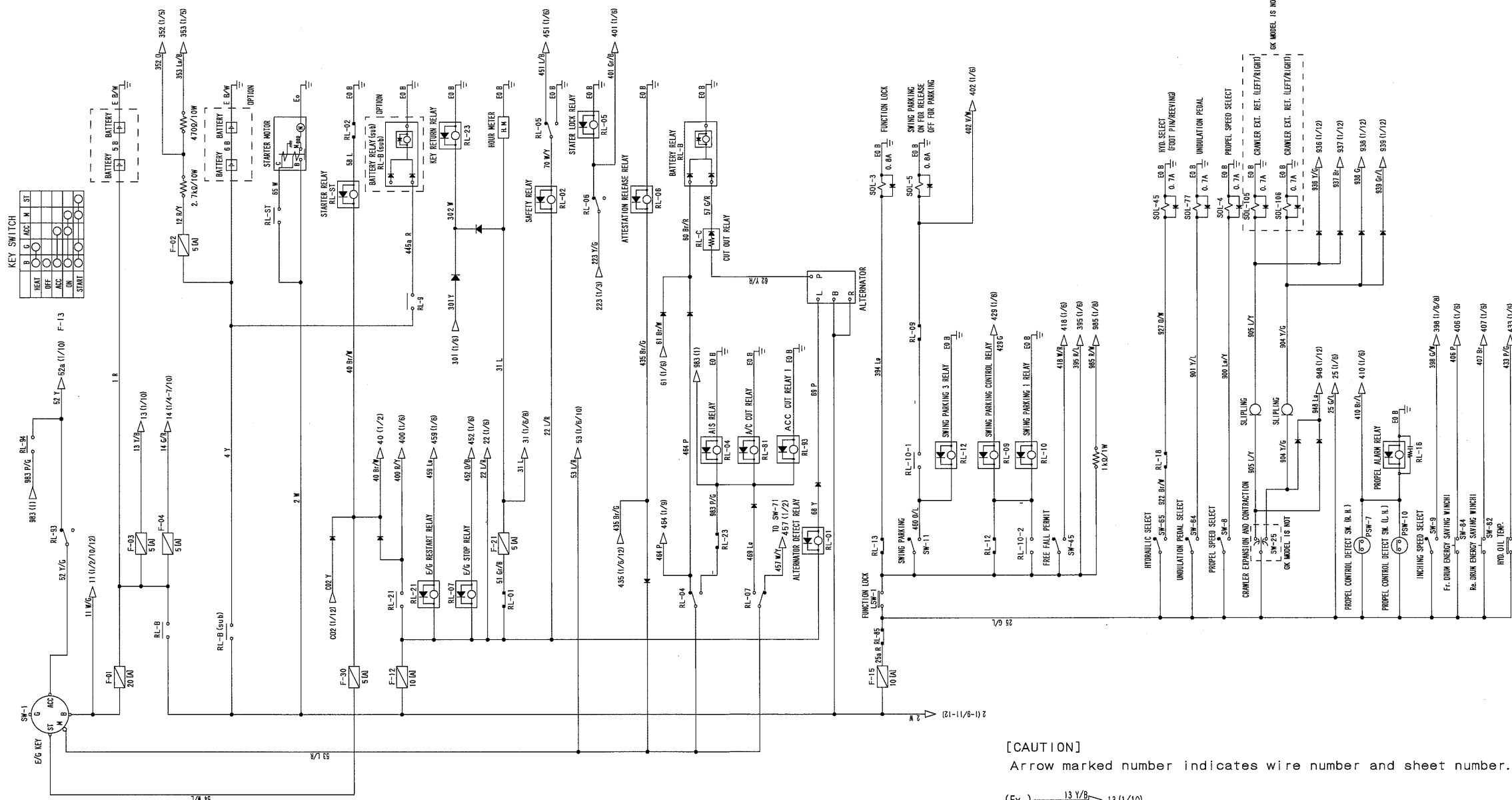

[CAUTION]
 Arrow marked number indicates wire number and sheet number.

- (Ex.) \rightarrow 13 Y/B \rightarrow 13 (1/10)
 SHEET 10
 SHEET 1
 Wire number 13
- (Ex.) \rightarrow 2 W \rightarrow 2 (1-9/11-12)
 SHEET 11 to 12
 SHEET 1 to 9

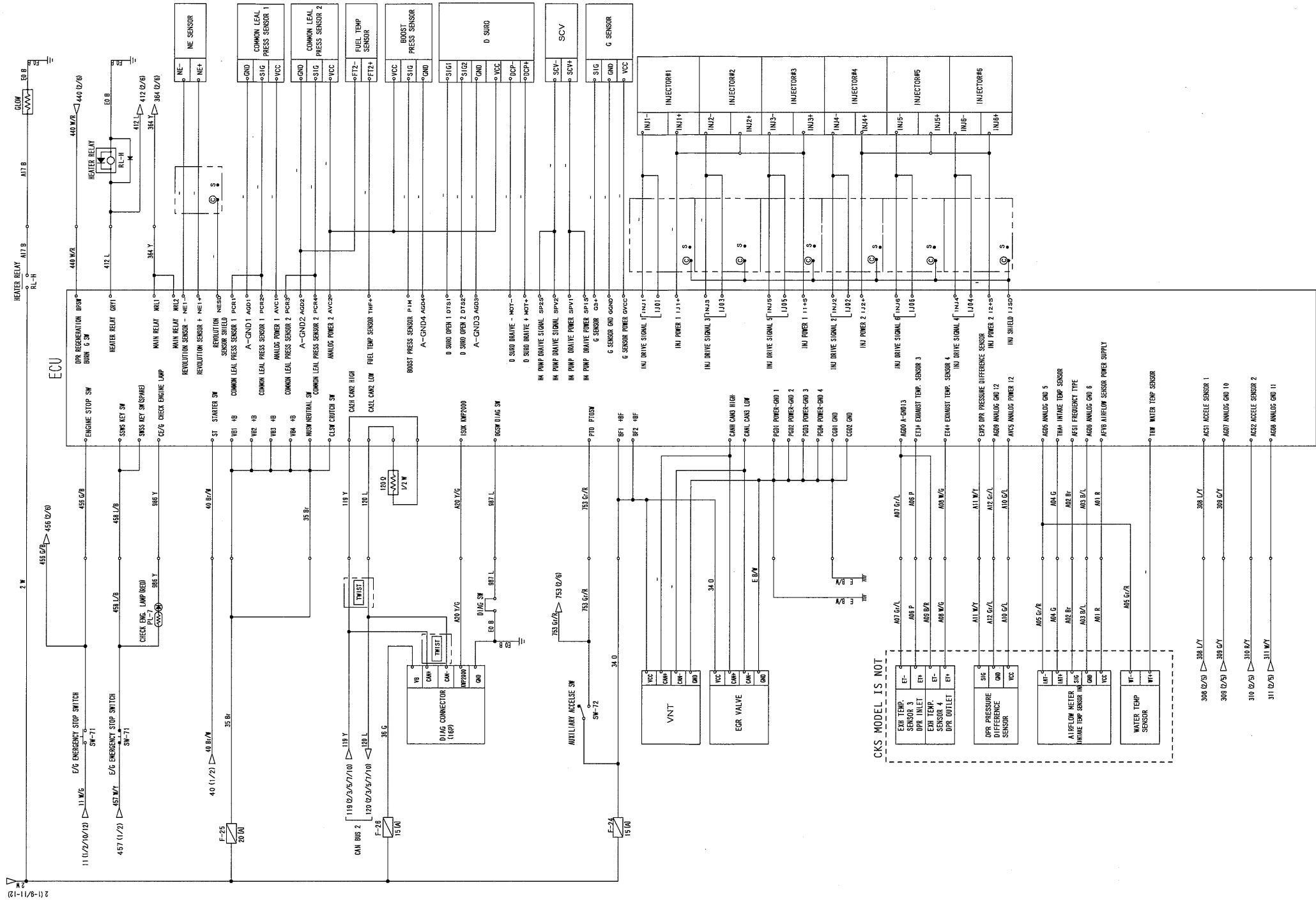

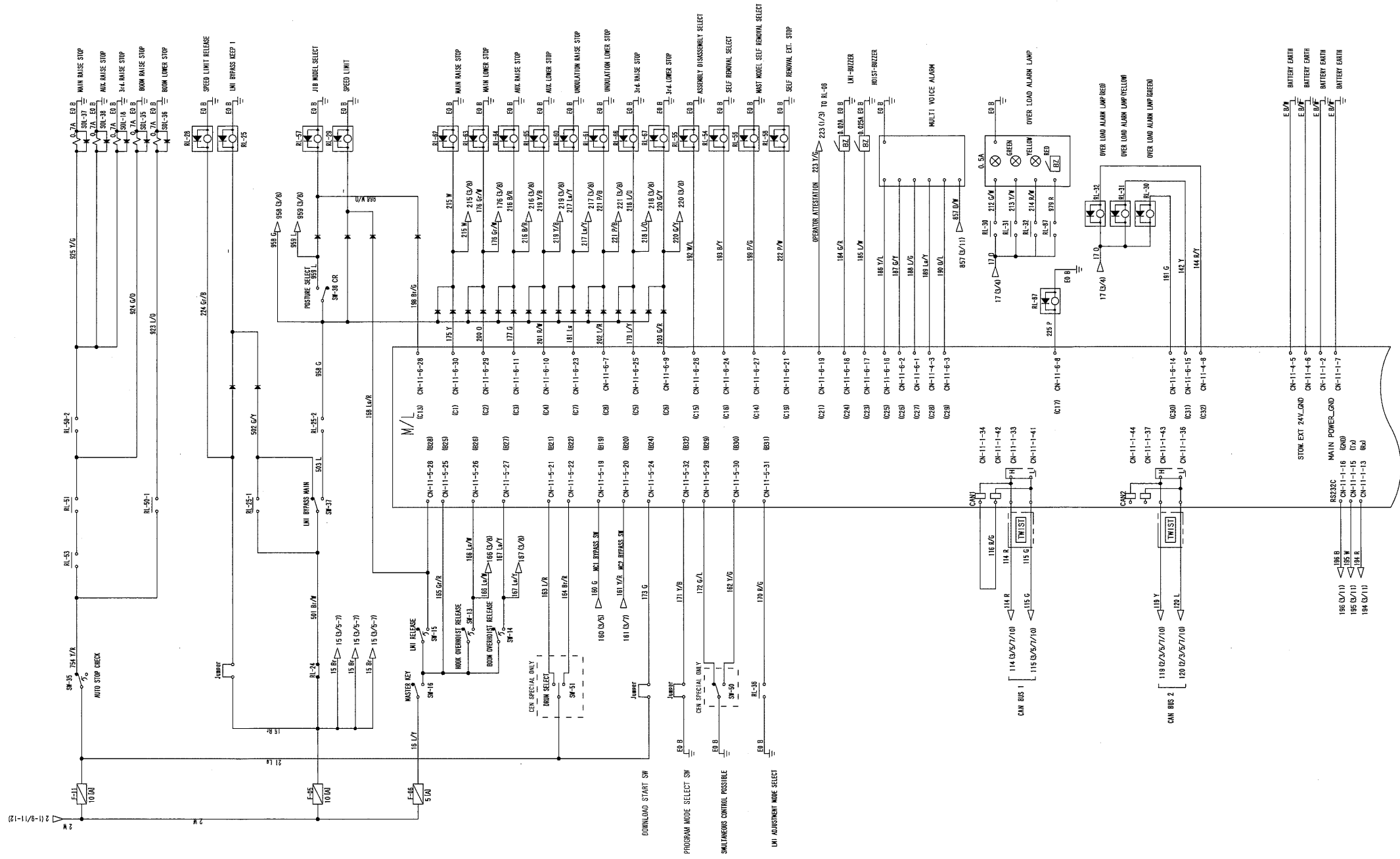

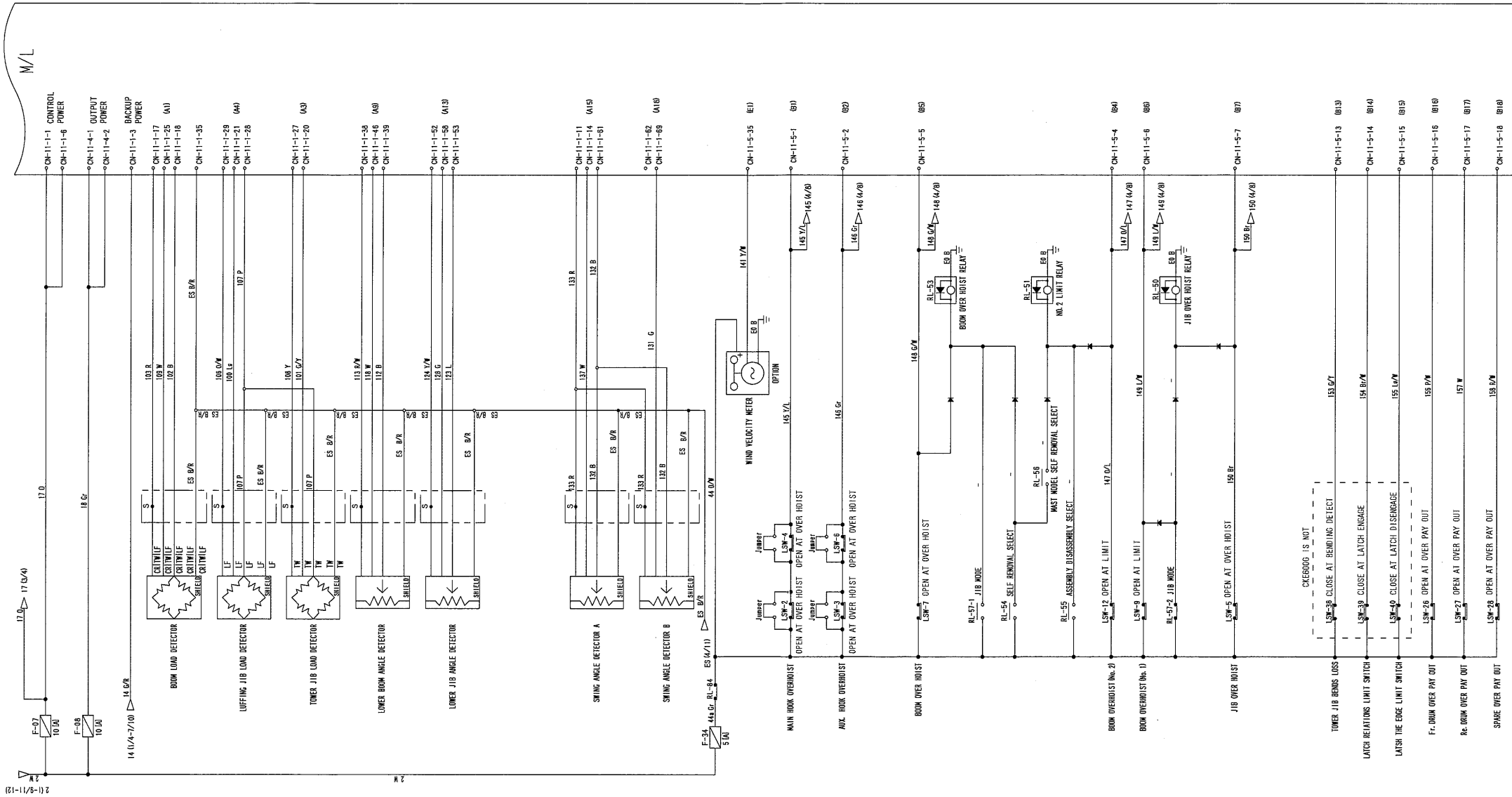

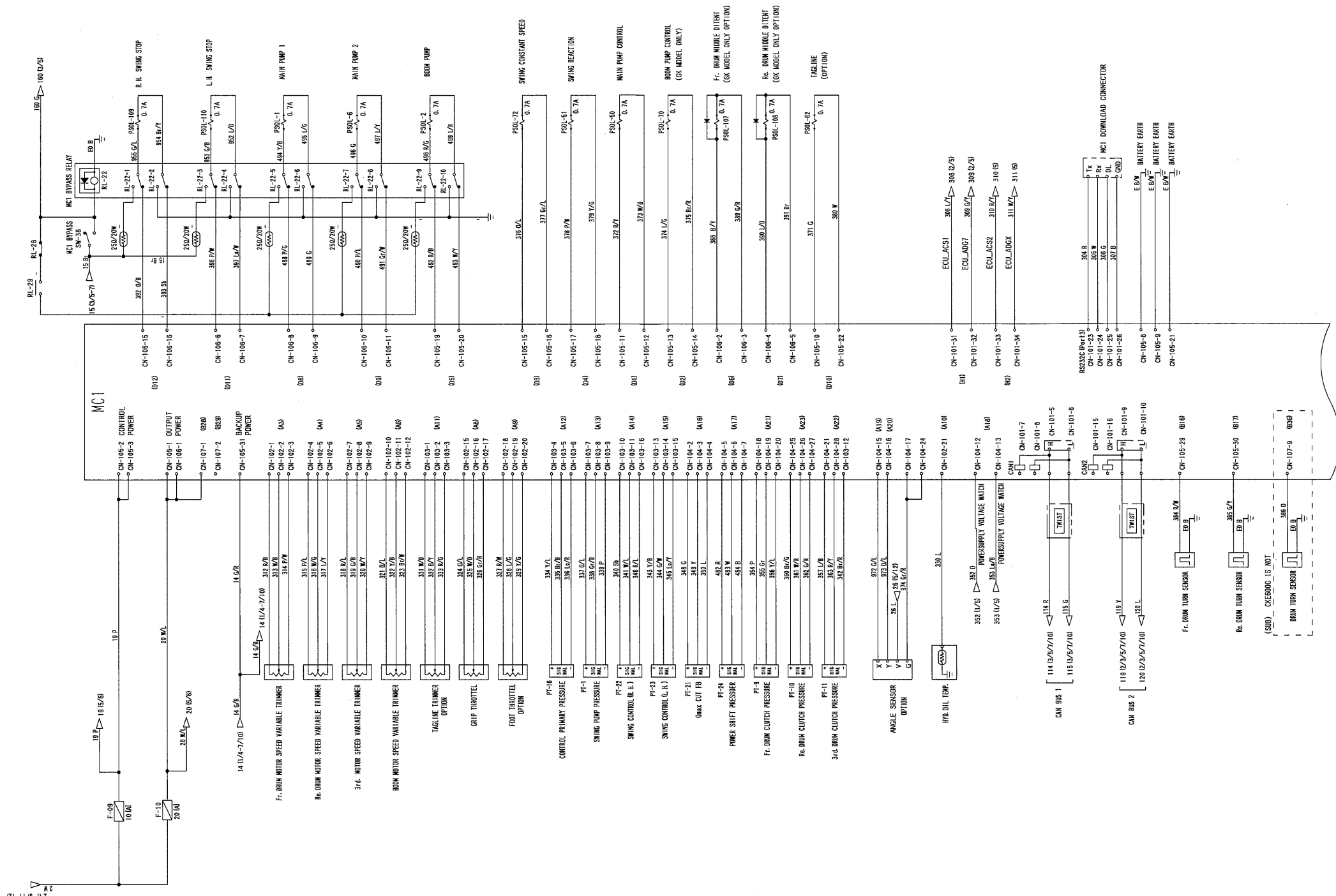

2 (1-9/11-12)

GG03Z00026P1 (5/18)

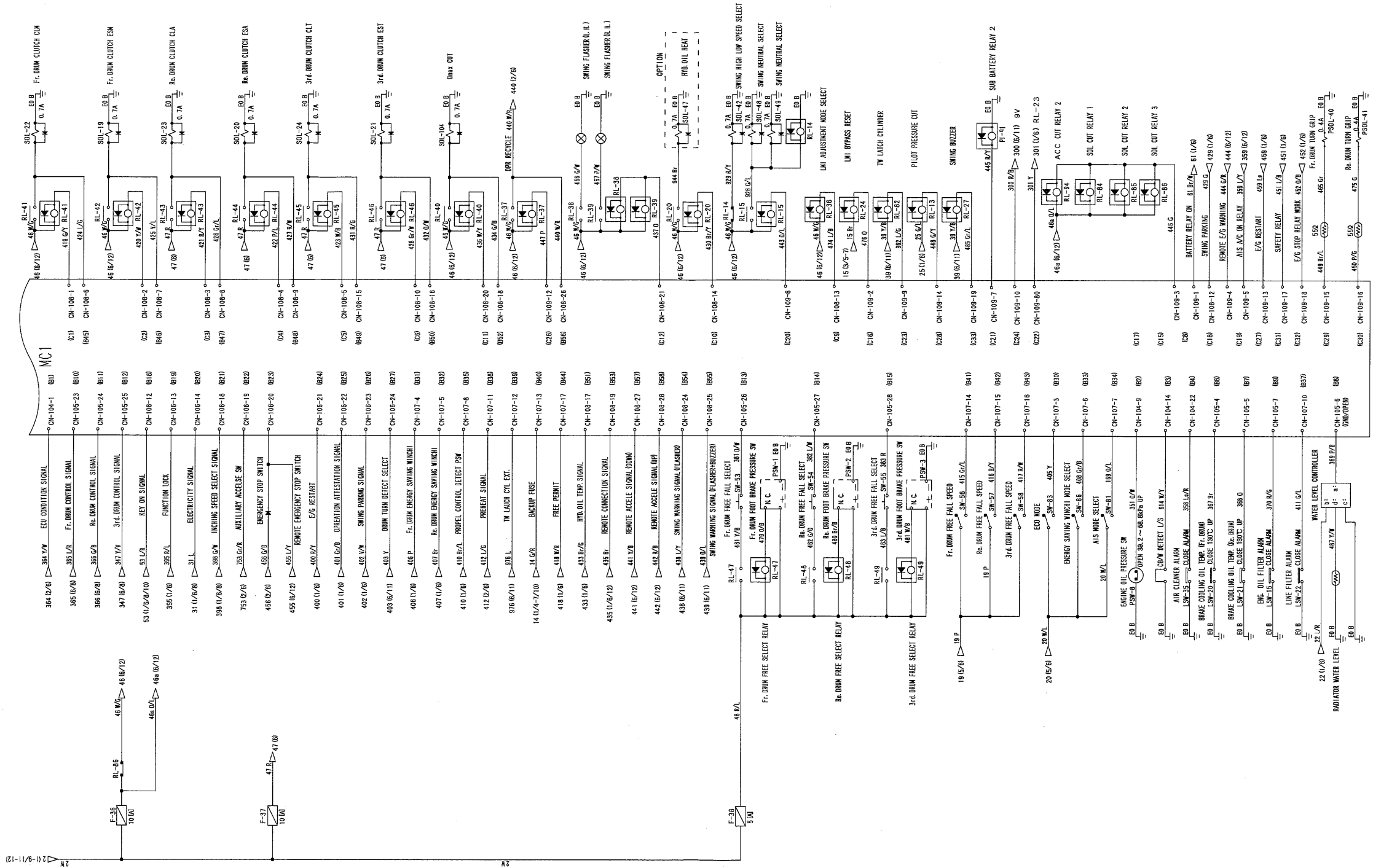

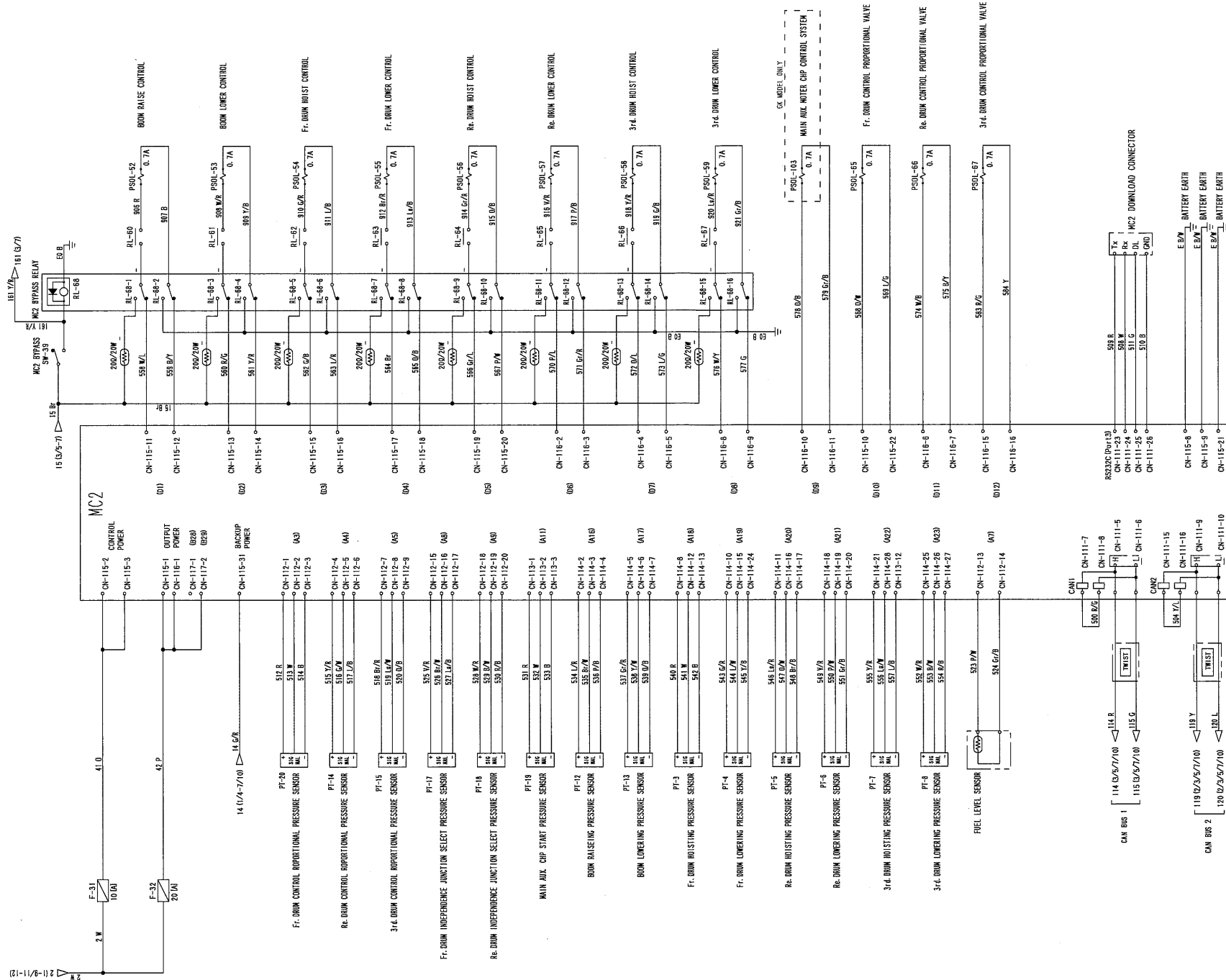

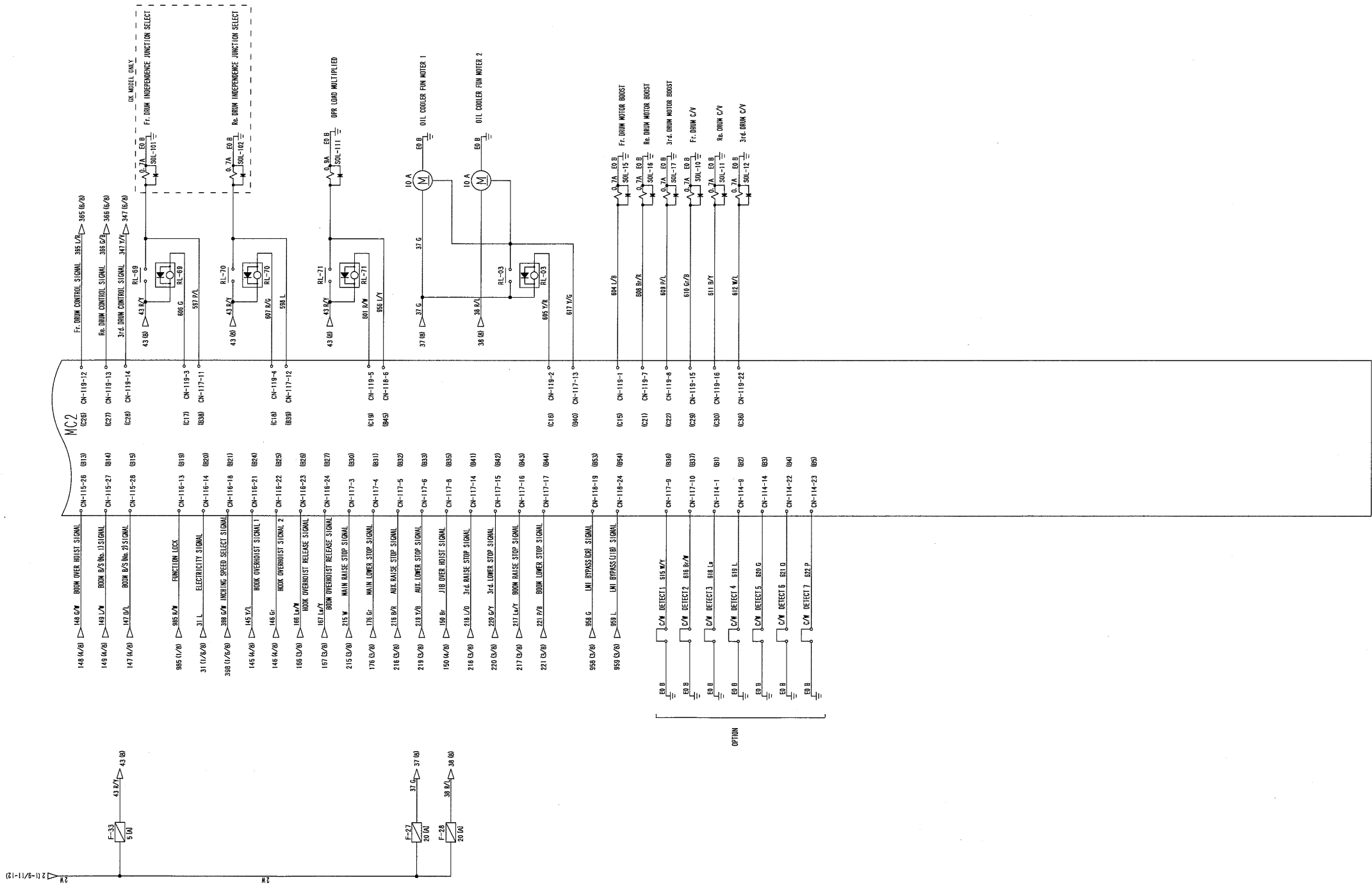

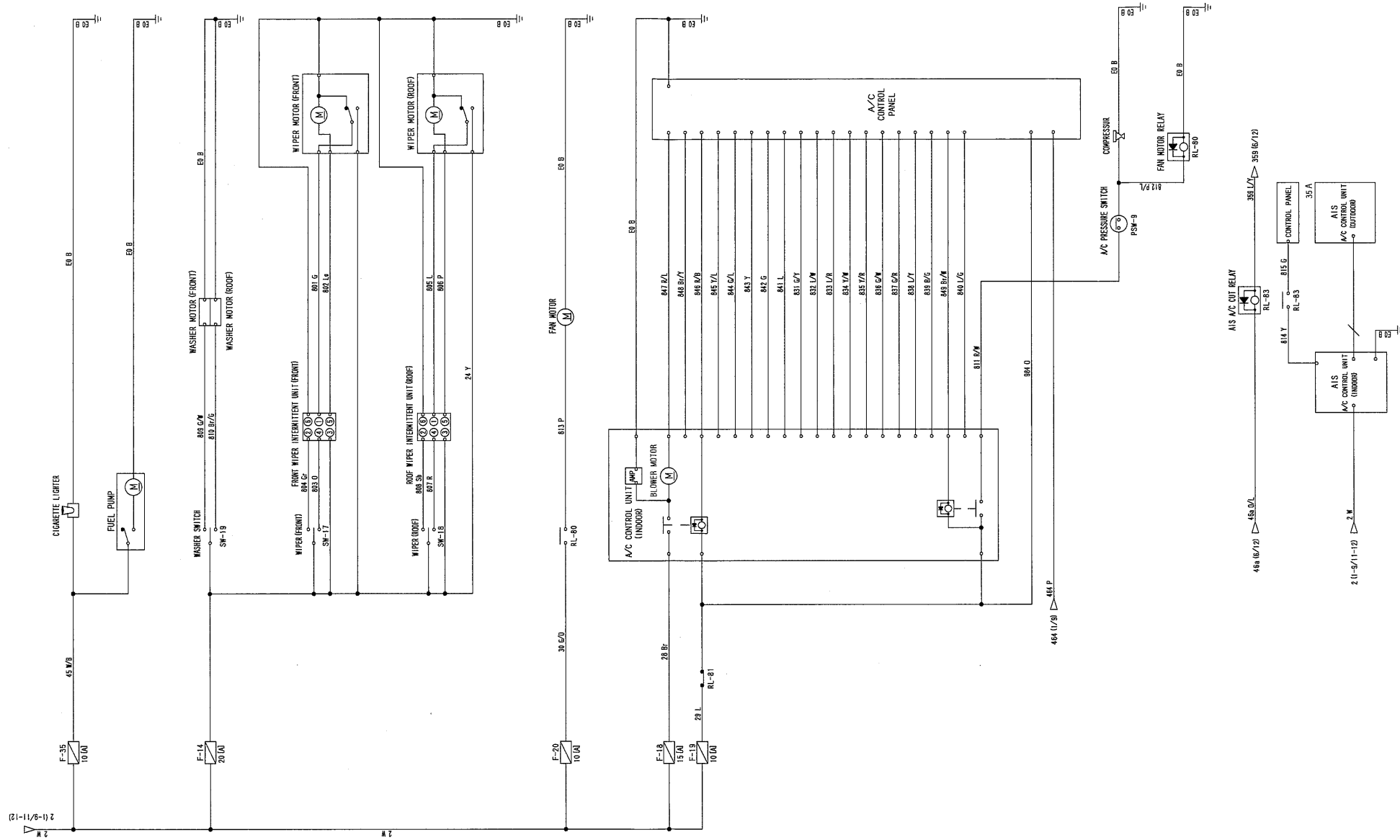

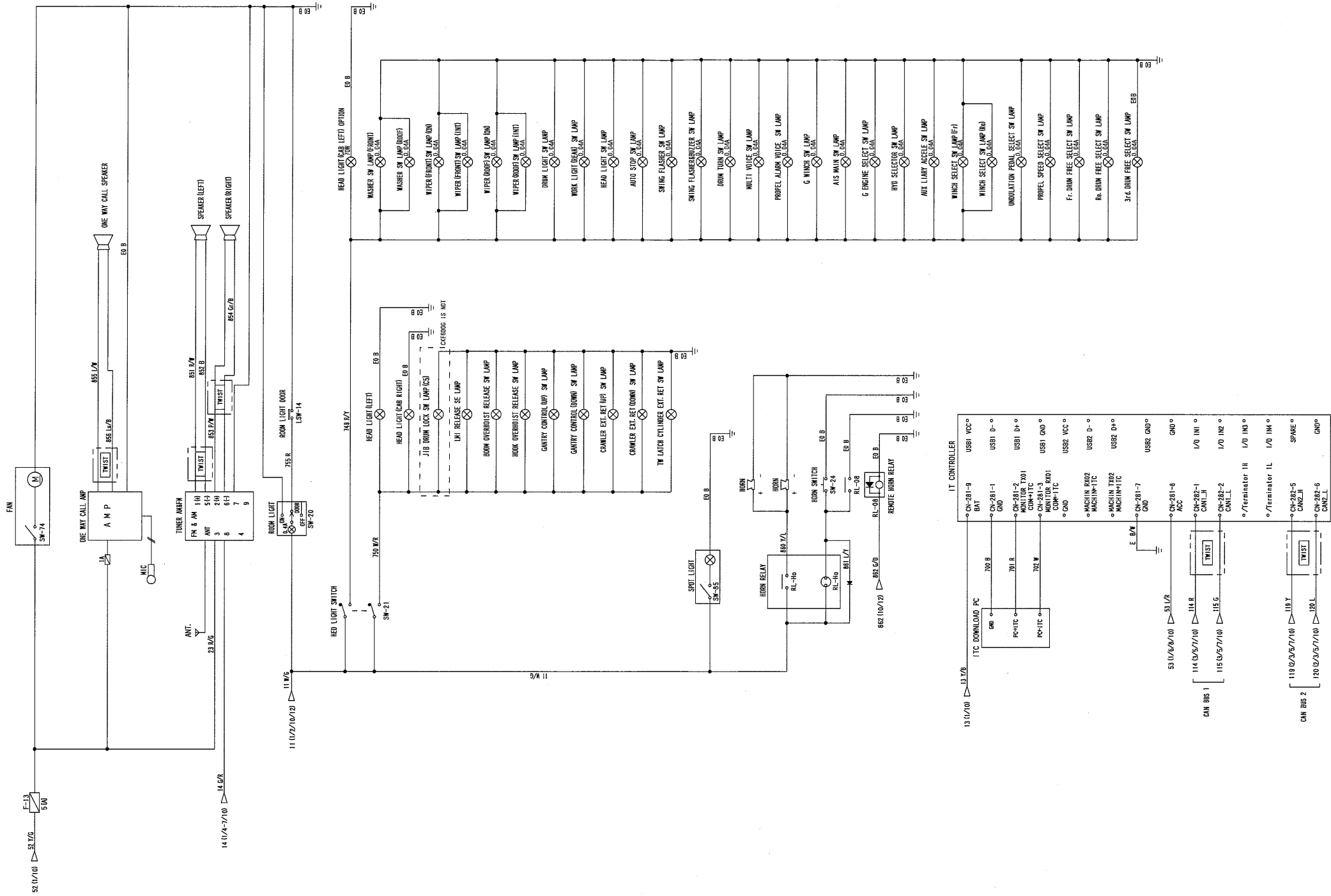

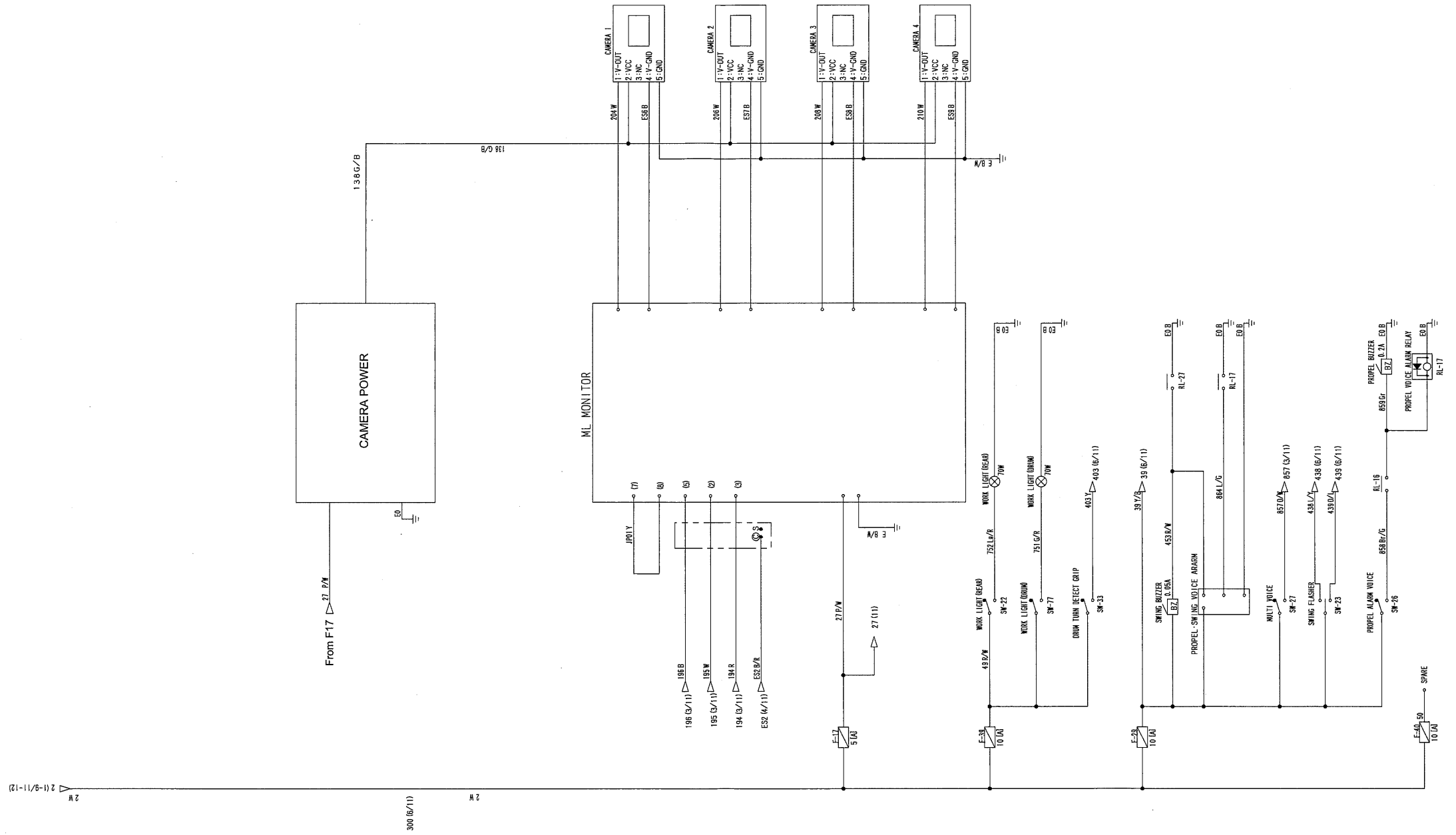

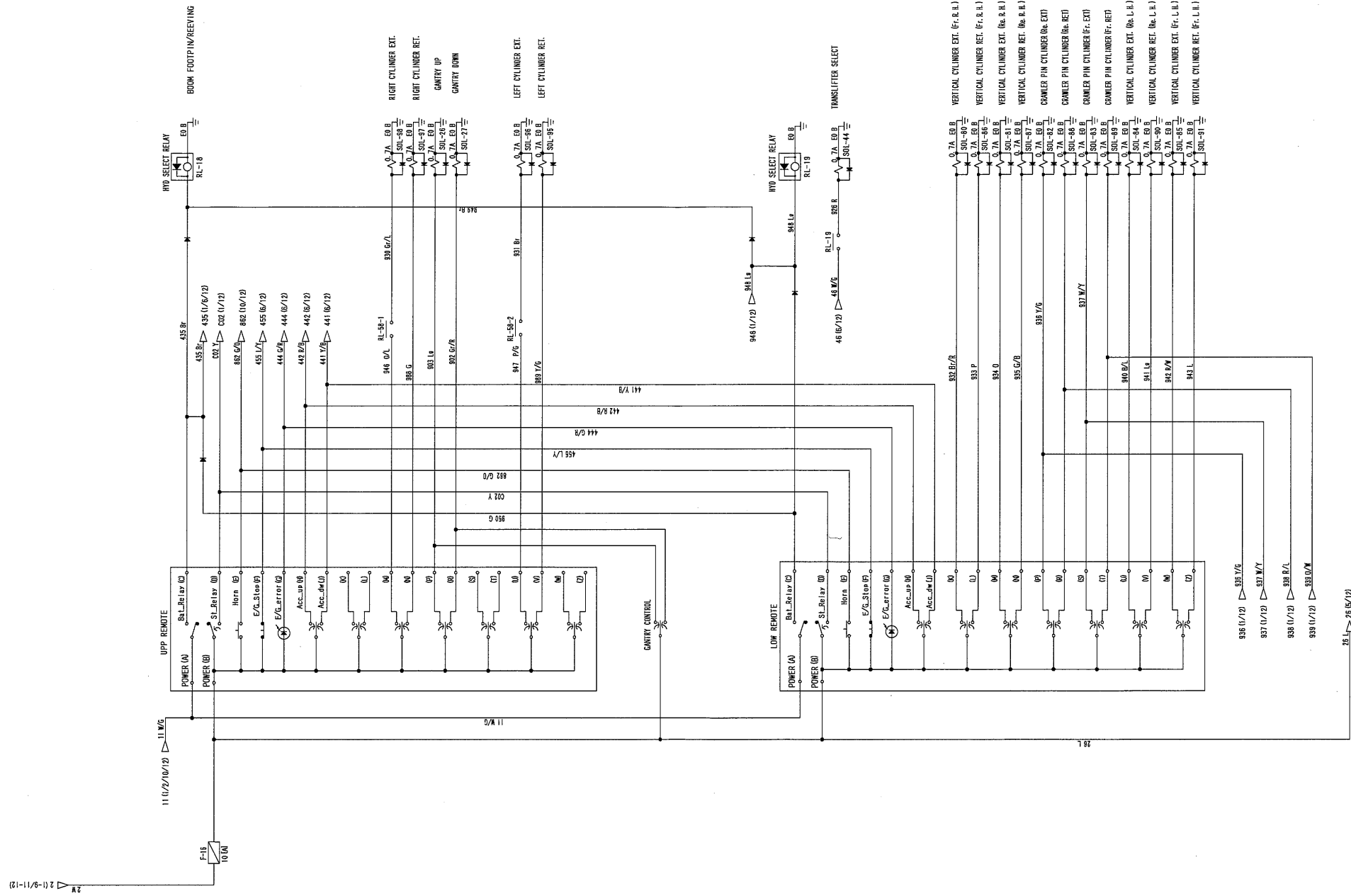

RELAY					
RL-NO.	COIL SHEET No.	TERMINAL SHEET No.	TYPE	U S E	KOBELCO PART NO. (Reference only. Please double check by Part Manual.)
RL-B(sub)	1	1	NO	BATTERY RELAY (sub)	EZ24S00027F1
RL-B	1	1	NO	BATTERY RELAY	EZ24S00027F1
RL-Ho	10	10	NO	HORN RELAY	4079Z22
RL-C	1		NO	CUT OUT RELAY	(27730-1050)
RL-H	2	2	NO	HEATER RELAY	(28620-1430)
RL-ST	1	1	NO	STARTER RELAY	(28410-1282)
RL-01	1	1	NC	ALTERNATOR DETECT RELAY	GG24E00038F1
RL-02	1	1	NC	SAFETY RELAY	EZ24S00011P1
RL-03	8	8	NO	OIL COOLER MOTER	EN24S00008P1
RL-04	1	1	NO NC	AIS RELAY	GG24E00038F1
RL-05	1	1	NO NC	STATER LOCK RELAY	
RL-06	1	1	NC	ATTESTATION RELEASE RELAY	
RL-07	1	1	NO NC	E/G STOP RELAY	
RL-08	10	10	NO	REMOTE HORN RELAY	
RL-09	1	1	NC	SWING PARKING CONTROL RELAY	
RL-10	1			SWING PARKING 1 RELAY	
RL-10-1		1	NO	SWING PARKING 1	
RL-10-2		1	NO	SWING PARKING 2	
RL-12	1	1	NC	SWING PARKING 3 RELAY	
RL-13	6	1	NC	PILOT PRESSURE CUT	

RELAY					
RL-NO.	COIL SHEET No.	TERMINAL SHEET No.	TYPE	U S E	KOBELCO PART NO. (Reference only. Please double check by Part Manual.)
RL-14	6	6	NC	SWING HIGH LOW SPEED SELECT	GG24E00038F1
RL-15	6	6	NO	SWING NEUTRAL BRAKE SELECT	
RL-16	1	11	NO	PROPEL ALARM RELAY	
RL-17	11	11	NO	PROPEL VOICE ALARM RELAY	
RL-18	12	1	NC	HYD SELECT RELAY	
RL-19	12	12	NO	HYD SELECT RELAY	
RL-20	6	6	NO	HYD.OIL HEAT	
RL-21	1	1	NO	E/G RESTART RELAY	
RL-22	5			MC1 BYPASS RELAY	
RL-22-1		5	NO NC	MC1 BYPASS RELAY	
RL-22-2		5	NO NC	MC1 BYPASS RELAY	
RL-22-3		5	NO NC	MC1 BYPASS RELAY	
RL-22-4		5	NO NC	MC1 BYPASS RELAY	
RL-22-5		5	NO NC	MC1 BYPASS RELAY	
RL-22-6		5	NO NC	MC1 BYPASS RELAY	
RL-22-7		5	NO NC	MC1 BYPASS RELAY	
RL-22-8		5	NO NC	MC1 BYPASS RELAY	
RL-22-9		5	NO NC	MC1 BYPASS RELAY	
RL-22-10		5	NO NC	MC1 BYPASS RELAY	
RL-23	1	1	NC	KEY RETURN RELAY	

RELAY					
RL-NO.	COIL SHEET No.	TERMINAL SHEET No.	TYPE	U S E	KOBELCO PART NO. (Reference only. Please double check by Part Manual.)
RL-24	6	3	NC	LMI BYPASS RESET	GG24E00038F1
RL-25	3			LMI BYPASS KEEP 1	
RL-25-1		3	NO	LMI BYPASS KEEP 1	
RL-25-2		3	NO	LMI BYPASS KEEP 2	
RL-27	6	11	NO	SWING BUZZER	
RL-28	3	5	NC	SPEED LIMIT RELEASE	
RL-29	3	5	NO	SPEED LIMIT	
RL-30	3	3	NO	OVER LOAD ALARM LAMP (GREEN)	
RL-31	3	3	NO	OVER LOAD ALARM LAMP (YELLOW)	
RL-32	3	3	NO	OVER LOAD ALARM LAMP (RED)	
RL-36	6	3	NO	LMI ADJUSTMENT MODE SELECT	
RL-37	6	6	NO	DPR RECYCLE RELAY	
RL-38	6	6	NO	SWING FLASHER (L. H.) RELAY	
RL-39	6	6	NO	SWING FLASHER (R. H.) RELAY	
RL-40	6	6	NO	Qmax CUT RELAY	
RL-41	6	6	NO	CLM RELAY	
RL-42	6	6	NO	ESM RELAY	
RL-43	6	6	NO	CLA RELAY	
RL-44	6	6	NO	ESA RELAY	
RL-45	6	6	NO	CLT RELAY	

RELAY						
RL-NO.	COIL SHEET No.	TERMINAL SHEET No.	TYPE	U S E	KOBELCO PART NO. (Reference only. Please double check by Part Manual.)	
RL-46	6	6	NO	EST RELAY	GG24E00036F1	
RL-47	6	6	NO	Fr. DRUM FREE SELECT RELAY		
RL-48	6	6	NO	Re. DRUM FREE SELECT RELAY		
RL-49	6	6	NO	3rd. DRUM FREE SELECT RELAY		
RL-50	4			JIB OVER HOIST RELAY		
RL-50-1		3	NO	JIB OVER HOIST RELAY		
RL-50-2		3	NO	JIB OVER HOIST RELAY		
RL-51	4	3	NO	NO. 2 LIMIT RELAY		
RL-53	4	3	NO	BOOM OVER HOIST RELAY		
RL-54	3	4	NO	SELF REMOVAL SELECT		
RL-55	3	4	NO	ASSEMBLY DISASSEMBLY SELECT		
RL-56	3	4	NO	MAST MODEL SELF REMOVAL SELECT		
RL-57	3			JIB MODE SELECT		
RL-57-1		4	NO	JIB MODE		
RL-57-2		4	NC	JIB MODE		
RL-58	3			SELF REMOVAL EXT. STOP		
RL-58-1		12	NO	SELF REMOVAL EXT. STOP		
RL-58-2		12	NO	SELF REMOVAL EXT. STOP		
RL-60	3	7	NO	UNDULATION RAISE STOP		GG24E00036F1
RL-61	3	7	NO	UNDULATION LOWER STOP		

RELAY					
RL-NO.	COIL SHEET No.	TERMINAL SHEET No.	TYPE	U S E	KOBELCO PART NO. (Reference only. Please double check by Part Manual.)
RL-62	3	7	NO	MAIN RAISE STOP	GG24E00036F1
RL-63	3	7	NO	MAIN LOWER STOP	
RL-64	3	7	NO	AUX RAISE STOP	
RL-65	3	7	NO	AUX. LOWER STOP	
RL-66	3	7	NO	3rd. RAISE STOP	
RL-67	3	7	NO	3rd. LOWER STOP	
RL-68	7			MC2 BYPASS RELAY	
RL-68-1		7	NO NC	MC2 BYPASS RELAY	
RL-68-2		7	NO NC	MC2 BYPASS RELAY	
RL-68-3		7	NO NC	MC2 BYPASS RELAY	
RL-68-4		7	NO NC	MC2 BYPASS RELAY	
RL-68-5		7	NO NC	MC2 BYPASS RELAY	
RL-68-6		7	NO NC	MC2 BYPASS RELAY	
RL-68-7		7	NO NC	MC2 BYPASS RELAY	
RL-68-8		7	NO NC	MC2 BYPASS RELAY	
RL-68-9		7	NO NC	MC2 BYPASS RELAY	
RL-68-10		7	NO NC	MC2 BYPASS RELAY	
RL-68-11		7	NO NC	MC2 BYPASS RELAY	
RL-68-12		7	NO NC	MC2 BYPASS RELAY	
RL-68-13		7	NO NC	MC2 BYPASS RELAY	

RELAY					
RL-NO.	COIL SHEET No.	TERMINAL SHEET No.	TYPE	U S E	KOBELCO PART NO. (Reference only. Please double check by Part Manual.)
RL-68-14		7	NO NC	MC2 BYPASS RELAY	GG24E00036F1
RL-68-15		7	NO NC	MC2 BYPASS RELAY	
RL-68-16		7	NO NC	MC2 BYPASS RELAY	
RL-69	8	8	NO	Fr. DRUM INDEPENDENCE JUNCTION SELECT RELAY	
RL-70	8	8	NO	Re. DRUM INDEPENDENCE JUNCTION SELECT RELAY	
RL-71	8	8	NO	DPR LOAD MULTIPLIED RELAY	EN24S00008P1
RL-80	9	9	NO	FUN MOTOR RELAY	EN24S00008P1
RL-81	1	9	NC	A/C CUT RELAY	EN24S00008P1
RL-82	6	11	NO	TW LATCH CYLINDER	EN24S00008P1
RL-83	9	9	NO	AIS A/C CUT RELAY	EN24S00008P1
RL-84	6	4	NC	SOL CUT RELAY 1	EN24S00008P1
RL-85	6	1	NC	SOL CUT RELAY 2	EN24S00008P1
RL-86	6	6	NC	SOL CUT RELAY 3	EN24S00008P1
RL-87	3	3	NO	OVER LOAD ALARM BUZZER (RED)	EN24S00008P1
RL-91	6	1	NO	SUB BATTERY RELAY 2	EN24S00008P1
RL-93	1	1	NC	ACC CUT RELAY 1	EN24S00008P1
RL-94	6	1	NO	ACC CUT RELAY 2	EN24S00008P1

FUSE				
F-NO.	RATED	U S E	SHEET NO.	KOBELCO PART NO. (Reference only. Please double check by Part Manual.)
F-01	20	ELECTRIC POWER SOURCE	1	2479Z2812D9
F-02	5	POWERSUPPLY-VOLTAGE WATCH RELAY	1	2479Z2812D5
F-03	5	ITC and RADIO POWER SOURCE	1	2479Z2812D5
F-04	5	ML BACK-UP	1	2479Z2812D5
F-05	10	BYPASS SWITCH	3	2479Z2812D7
F-06	5	RELEASE SWITCH	3	2479Z2812D5
F-07	10	LMI CONTROL POWER	4	2479Z2812D7
F-08	10	LMI OUTPUT POWER	4	2479Z2812D7
F-09	10	MC1 CONTROL POWER	5	2479Z2812D7
F-10	20	MC1 OUTPUT POWER	5	2479Z2812D9
F-11	10	AUTO STOP	3	2479Z2812D7
F-12	10	E/G CONDITION	1	2479Z2812D7
F-13	5	ONE WAY/RADIO	10	2479Z2812D5
F-14	20	WIPER	9	2479Z2812D9
F-15	10	FUNCTION LOCK	1	2479Z2812D7
F-16	10	REMOTE	12	2479Z2812D7
F-17	5	MONITOR	11	2479Z2812D5
F-18	15	A/C	9	2479Z2812D8
F-19	10	A/C 2	9	2479Z2812D7
F-20	10	FUN MOTOR	9	2479Z2812D7

FUSE				
F-NO.	RATED	U S E	SHEET NO.	KOBELCO PART NO. (Reference only. Please double check by Part Manual.)
F-21	5	GENERATION OF ELECTRICITY SENSOR	1	2479Z2812D5
F-24	15	ECU (+BF)	2	2479Z2812D8
F-25	20	ECU (+B)	2	2479Z2812D9
F-26	15	ECU	2	2479Z2812D8
F-27	20	OIL COOLER FUN MOTER 1	8	2479Z2812D9
F-28	30	OIL COOLER FUN MOTER 2	8	2479Z2812D11
F-29	10	SWING FLASHER/VOICE ARARM	11	2479Z2812D7
F-30	5	STARTER	1	2479Z2812D5
F-31	10	MC2 CONTROL POWER	7	2479Z2812D7
F-32	20	MC2 OUTPUT POWER	7	2479Z2812D9
F-33	5	MC2 EARTH OUTPUT POWER	8	2479Z2812D5
F-34	5	OVERHOIST L/S	4	2479Z2812D5
F-35	10	FUEL PUMP/CIGARETTE LIGHTER	9	2479Z2812D7
F-36	10	MC1 EARTH OUTPUT POWER 1	6	2479Z2812D7
F-37	10	MC1 EARTH OUTPUT POWER 2	6	2479Z2812D7
F-38	5	NEUTRAL FREE	6	2479Z2812D5
F-39	10	LIGHT	11	2479Z2812D7
F-40	10	SPARE	11	2479Z2812D7

SOLENOID VALVE				
SOL-NO.	U S E	SHEET NO.	KOBELCO PART NO. (Reference only. Please double check by Part Manual.)	
SOL-3	FUNCTION LOCK	1	YN35V00027F2	
SOL-4	PROPEL SPEED SELECT	1	YN35V00027F2	
SOL-5	SWING PARKING ON FOR RELEASE OFF FOR PARKING	1	YN35V00027F2	
SOL-10	Fr. DRUM C/V	8	JJ35V00010F2	
SOL-11	Re. DRUM C/V	8	JJ35V00010F2	
SOL-12	3rd. DRUM C/V	8		
SOL-15	Fr. DRUM MOTOR BOOST	8		
SOL-16	Re. DRUM MOTOR BOOST	8	YN35V00050F1	
SOL-17	3rd. DRUM MOTOR BOOST	8		
SOL-18	3rd. RAISE STOP	3		
SOL-19	Fr. DRUM CLUTCH ESM	6	JJ35V00008F1	
SOL-20	Re. DRUM CLUTCH ESA	6	JJ35V00008F1	
SOL-21	3rd. DRUM CLUTCH EST	6	GG35V00014F1	
SOL-22	Fr. DRUM CLUTCH CLM	6	JJ35V00008F1	
SOL-23	Re. DRUM CLUTCH CLA	6	JJ35V00008F1	
SOL-24	3rd. DRUM CLUTCH CLT	6	GG35V00014F1	
SOL-26	GANTRY UP	12	JJ30V00024F1	
SOL-27	GANTRY DOWN	12	JJ30V00024F1	
SOL-35	BOOM RAISE STOP	3	JJ35V00009F2	

SOLENOID VALVE				
SOL-NO.	U S E	SHEET NO.	KOBELCO PART NO. (Reference only. Please double check by Part Manual.)	
SOL-36	BOOM LOWER STOP	3	JJ35V00009F2	
SOL-37	MAIN RAISE STOP	3	JJ35V00009F2	
SOL-38	AUX. RAISE STOP	3	JJ35V00009F2	
SOL-42	SWING HIGH LOW SPEED SELECT	6	YN35V00027F2	
SOL-44	TRANSLIFTER SELECT	12	JJ30V00024F1	
SOL-45	HYD. SELECT (FOOT PIN/REEVING)	1	JJ30V00024F1	
SOL-47	HYD. OIL HEAT	6	GG27V00001F1	
SOL-48	SWING NEUTRAL SELECT	6	GB15V00004F1	
SOL-49	SWING NEUTRAL SELECT	6	GB15V00004F1	
SOL-69	JIB UNDULATION DRUM LOCK (ON FOR UNLOCK)	1	EE35V00007F1	
SOL-77	UNDULATION PEDAL	1	EN35V00038F1	
SOL-80	VERTICAL CYLINDER EXT. (Fr. R. H.)	12		
SOL-81	VERTICAL CYLINDER EXT. (Re. R. H.)	12		
SOL-82	CRAWLER PIN CYLINDER (Re. EXT)	12		
SOL-83	CRAWLER PIN CYLINDER (Fr. EXT)	12		
SOL-84	VERTICAL CYLINDER EXT. (Re. L. H.)	12	JJ30V00015F3	
SOL-85	VERTICAL CYLINDER EXT. (Fr. L. H.)	12		
SOL-86	VERTICAL CYLINDER RET. (Fr. R. H.)	12		
SOL-87	VERTICAL CYLINDER RET. (Re. R. H.)	12		
SOL-88	CRAWLER PIN CYLINDER (Re. RET)	12		

SOLENOID VALVE			
SOL-NO.	U S E	SHEET NO.	KOBELCO PART NO. (Reference only, Please double check by Part Manual.)
SOL-89	CRAWLER PIN CYLINDER (Fr. RET)	12	JJ30V00015F3
SOL-90	VERTICAL CYLINDER RET. (Re. L.H.)	12	
SOL-91	VERTICAL CYLINDER RET. (Fr. L.H.)	12	
SOL-95	LEFT CYLINDER RET.	12	GG30V00035F2
SOL-96	LEFT CYLINDER EXT.	12	
SOL-97	RIGHT CYLINDER RET.	12	
SOL-98	RIGHT CYLINDER EXT.	12	
SOL-101	Fr. DRUM INDEPENDENCE JUNCTION SELECT	8	GG35V00015F1
SOL-102	Re. DRUM INDEPENDENCE JUNCTION SELECT	8	GG35V00015F1
SOL-104	Qmax CUT	6	GG35V000019F1
SOL-105	CRAWLER EXT. RET. (LEFT/RIGHT)	1	GG30V00041F1
SOL-106	CRAWLER EXT. RET. (LEFT/RIGHT)	1	
SOL-111	DPR LOAD MULTIPLIED	8	GG20V00025F1

SOLENOID VALVE			
PSOL-NO.	U S E	SHEET NO.	KOBELCO PART NO. (Reference only, Please double check by Part Manual.)
PSOL-1	MAIN PUMP 1	5	GG35V00019F1
PSOL-2	BOOM PUMP	5	JD10V00003F1
PSOL-6	MAIN PUMP 2	5	GK35V00003F1
PSOL-40	Fr. DRUM TURN GRIP	6	GB50M01093F1
PSOL-41	Re. DRUM TURN GRIP	6	GB50M01093F1
PSOL-50	MAIN PUMP CONTROL	5	GG10V00025F1
PSOL-51	SWING REACTION	5	YM35V00001F2
PSOL-52	BOOM RAISE CONTROL	7	GG20V00017F3
PSOL-53	BOOM LOWER CONTROL	7	GG20V00017F3
PSOL-54	Fr. DRUM HOIST CONTROL	7	GG20V00017F3
PSOL-55	Fr. DRUM LOWER CONTROL	7	GG20V00017F3
PSOL-56	Re. DRUM HOIST CONTROL	7	GG20V00017F3
PSOL-57	Re. DRUM LOWER CONTROL	7	GG20V00017F3
PSOL-58	3rd. DRUM HOIST CONTROL	7	GG20V00017F3
PSOL-59	3rd. DRUM LOWER CONTROL	7	GG20V00017F3
PSOL-62	TAGLINE	5	GB22V00007F1
PSOL-65	Fr. DRUM CONTROL PROPORTIONAL VALVE	7	GG15V00015F1
PSOL-66	Re. DRUM CONTROL PROPORTIONAL VALVE	7	GG15V00015F1
PSOL-67	3rd. DRUM CONTROL PROPORTIONAL VALVE	7	GG15V00015F1
PSOL-70	BOOM PUMP CONTROL	5	JD10V00003F1

SOLENOID VALVE			
PSOL-NO.	U S E	SHEET NO.	KOBELCO PART NO. (Reference only, Please double check by Part Manual.)
PSOL-72	SWING CONSTANT SPEED	5	GG10V00015F2
PSOL-103	MOTER CHP CONTROL SYSTEM	7	GG35V00015F1
PSOL-107	Fr. DRUM MIDDLE DITENT	5	GG30V00042F1
PSOL-108	Re. DRUM MIDDLE DITENT	5	GG30V00042F1
PSOL-109	R. H. SWING STOP	5	EE35V00012F1
PSOL-110	L. H. SWING STOP	5	EE35V00012F1

SWITCH			
SW-NO.	U S E	SHEET NO.	KOBELCO PART NO. (Reference only, Please double check by Part Manual.)
SW-1	E/G KEY	1	YN50S00026F1
SW-8	PROPEL SPEED SELECT	1	GG50S00061P1
SW-9	INCHING SPEED SELECT	1	(GG50M01032F1)
SW-11	SWING PARKING	1	(GB20E00001F3)
SW-12	GANTRY CONTROL	12	GG50S00071P1
SW-13	HOOK OVERHOIST RELEASE	3	GG50S00055P1
SW-14	BOOM OVERHOIST RELEASE	3	GG50S00054P1
SW-15	LMI RELEASE	3	GG50S00053P1
SW-16	MASTER KEY	3	JJ50S00015P1
SW-17	WIPER (FRONT)	9	GG50S00041P1
SW-18	WIPER (ROOF)	9	GG50S00042P1
SW-19	WASHER SWITCH	9	GG50S00040P1
SW-20	ROOM LIGHT	10	2456R315
SW-21	HED LIGHT SWITCH	10	GG50S00043P1
SW-22	WORK LIGHT (REAR)	11	GG50S00064P1
SW-23	SWING FLASHER	11	GG50S00046P1
SW-24	HORN SWITCH	10	(GB20E00001F3)
SW-25	CRAWLER EXPANSION AND CONTRACTION	1	GG50S00066P1
SW-26	PROPEL ALARM VOICE	11	GG50S00033P1
SW-27	MULTI VOICE	11	GG50S00034P1

SWITCH			
SW-NO.	U S E	SHEET NO.	KOBELCO PART NO. (Reference only, Please double check by Part Manual.)
SW-33	DRUM TURN DETECT GRIP	11	GG50S00032P1
SW-35	AUTO STOP CHECK	3	GG50S00045P1
SW-36	POSTURE SELECT	3	GG50S00073P1
SW-37	LMI BYPASS MAIN	3	
SW-38	MC1 BYPASS	5	2479Z2872
SW-39	MC2 BYPASS	7	
SW-45	FREE FALL PERMIT	1	GG50S00005P1
SW-50	SMULTANEOUS CONTROL POSSIBLE	3	JJ50S00005P1
SW-51	DRUM SELECT	3	GG50S00035P1
SW-53	Fr. DRUM FREE FALL SELECT	6	GG50E00006F5
SW-54	Re. DRUM FREE FALL SELECT	6	
SW-55	3rd. DRUM FREE FALL SELECT	6	
SW-56	Fr. DRUM FREE FALL SPEED	6	GG50S00056P1
SW-57	Re. DRUM FREE FALL SPEED	6	GG50S00057P1
SW-58	3rd. DRUM FREE FALL SPEED	6	GG50S00038P1
SW-64	UNDULATION PEDAL SELECT	1	GG50S00062P1
SW-65	HYDRAULIC SELECT	1	GG50S00059P1
SW-71	E/G EMERGENCY STOP SWITCH	2	GG50S00022P1
SW-72	AUXILIARY ACCELSW SW	2	GG50S00044P1
SW-74	FAN	10	(EN75S00002P1)

SWITCH			
SW-NO.	U S E	SHEET NO.	KOBELCO PART NO. (Reference only, Please double check by Part Manual.)
SW-75	LAUCH LOCK OPERATION	11	-
SW-77	WORK LIGHT (DRUM)	11	GG50S00063P1
SW-79	JIB UNDULATION DRUM LOCK	1	GG50S00001P1
SW-81	AIS MODE SELECT	6	GG50S00051P1
SW-82	Re. DRUM G WINCHI	1	GG50E00006F5
SW-83	G ENGINE	6	GG50S00052P1
SW-84	Fr. DRUM G WINCHI	1	GG50E00006F5
SW-85	SWITCH	10	-
SW-86	G WINCHI MODE SELECT	6	GG50S00050P1

LIMIT SWITCH			
LSW-NO.	U S E	SHEET NO.	KOBELCO PART NO. (Reference only, Please double check by Part Manual.)
LSW-1	FUNCTION LOCK	1	GB50S00038F1
LSW-2	MAIN HOOK OVERHOIST	4	24100N6192F5
LSW-3	AUX. HOOK OVERHOIST	4	24100N6192F5
LSW-4	HOOK OVERHOIST (AUX)	4	
LSW-5	JIB OVER HOIST	4	GG50S00015D1
LSW-6	HOOK OVERHOIST (JIB)	4	24100N6192F5
LSW-7	BOOM OVER HOIST	4	GG50S00004P1
LSW-9	BOOM OVERHOIST (No. 1)	4	GK50S00001P1
LSW-12	BOOM OVERHOIST (No. 2)	4	GK50S00001P1
LSW-14	ROOM LIGHT DOOR	10	2479R638
LSW-15	ENG OIL FILTER ALARM	6	-
LSW-20	BRAKE COOLING OIL TEMP. (Fr. DRUM)	6	GG50S00002D1
LSW-21	BRAKE COOLING OIL TEMP. (Re. DRUM)	6	GG50S00002D1
LSW-22	LINE FILTER ALARM	6	(GG50V00001F1)
LSW-24	MAST CYLINDER	4	GK50S00001P1
LSW-26	Fr. DRUM OVER PAY OUT	4	GG50S00013P1
LSW-27	Re. DRUM OVER PAY OUT	4	GG50S00013P1
LSW-28	SPARE OVER PAY OUT	4	GG50S00013P1
LSW-30	HYD. OIL TEMP.	1	GG50S00002D2
LSW-35	AIR CLEANER ALARM	6	-

LIMIT SWITCH			
LSW-NO.	U S E	SHEET NO.	KOBELCO PART NO. (Reference only, Please double check by Part Manual.)
LSW-38	TOWER JIB BENDS LOSS	4	GB50S00024D1
LSW-39	LATCH RELATIONS LIMIT SWITCH	4	GG50S00017D1
LSW-40	LATSH THE EDGE LIMIT SWITCH	4	GG50S00018D1
LSW-41	GANTRY STAND UP DETECT	4	GK50S00001P1

PRESSURE SWITCH				
PSW-NO.	TYPE	U S E	SHEET NO.	KOBELCO PART NO. (Reference only, Please double check by Part Manual.)
PSW-1	N.D.	Fr. DRUM FOOT BRAKE PRESSURE SW	6	GG50S00006P1
PSW-2	N.D.	Re. DRUM FOOT BRAKE PRESSURE SW	6	
PSW-3	N.D.	3rd. DRUM FOOT BRAKE PRESSURE SW	6	
PSW-7	N.D.	PROPEL CONTROL DETECT SW. (R. H.)	1	GG50S00007F1
PSW-8	N.C.	ENGINE OIL PRESSURE SW	6	-
PSW-9	N.D.	A/C PRESSURE SWITCH	9	-
PSW-10	N.D.	PROPEL CONTROL DETECT SW. (L. H.)	1	GG50S00007F1

PRESSURE SENSOR			
PT-NO.	U S E	SHEET NO.	KOBELCO PART NO. (Reference only, Please double check by Part Manual.)
PT-1	SWING PUMP PRESSURE	5	LS52S00015P1
PT-3	Fr. DRUM HOISTING PRESSURE SENSOR	7	LC52S00019P1
PT-4	Fr. DRUM LOWERING PRESSURE SENSOR	7	LC52S00019P1
PT-5	Re. DRUM HOISTING PRESSURE SENSOR	7	LC52S00019P1
PT-6	Re. DRUM LOWERING PRESSURE SENSOR	7	LC52S00019P1
PT-7	3rd. DRUM HOISTING PRESSURE SENSOR	7	LC52S00019P1
PT-8	3rd. DRUM LOWERING PRESSURE SENSOR	7	LC52S00019P1
PT-9	Fr. DRUM CLUTCH PRESSURE	5	GN52S00002P1
PT-10	Re. DRUM CLUTCH PRESSURE	5	GN52S00002P1
PT-11	3rd. DRUM CLUTCH PRESSURE	5	GN52S00002P1
PT-12	BOOM RAISING PRESSURE SENSOR	7	LC52S00019P1
PT-13	BOOM LOWERING PRESSURE SENSOR	7	LC52S00019P1
PT-14	Re. DRUM CONTROL ROPORTIONAL PRESSURE SENSOR	7	LC52S00019P1
PT-15	3rd. DRUM CONTROL ROPORTIONAL PRESSURE SENSOR	7	LC52S00019P1
PT-16	CONTROL PRIMARY PRESSURE	5	GN52S00002P1
PT-17	Fr. DRUM INDEPENDENCE JUNCTION SELECT PRESSURE SENSOR	7	LC52S00015P1
PT-18	Re. DRUM INDEPENDENCE JUNCTION SELECT PRESSURE SENSOR	7	LC52S00015P1
PT-19	MAIN AUX. CHP START PRESSURE SENSOR	7	LC52S00019P1

PRESSURE SENSOR			
PT-NO.	U S E	SHEET NO.	KOBELCO PART NO. (Reference only, Please double check by Part Manual.)
PT-20	Fr. DRUM CONTROL ROPORTIONAL PRESSURE SENSOR	7	LC52S00019P1
PT-21	Qmax CUT FB	5	LC52S00015P1
PT-22	SWING CONTROL (R. H.)	5	LC52S00019P1
PT-23	SWING CONTROL (L. H.)	5	LC52S00019P1
PT-24	POWER SHIFT PRESSUER	5	LC52S00019P1

PIROT LAMP			
PL-NO.	U S E	SHEET NO.	KOBELCO PART NO. (Reference only, Please double check by Part Manual.)
PL-7	CHECK ENG. LAMP (RED)	2	JJ80S00006D2

**CALIFORNIA EMISSION CONTROL
WARRANTY STATEMENT
YOUR WARRANTY RIGHTS AND OBLIGATIONS**

The California Air Resources Board (CARB), the Environmental Protection Agency (EPA) and HINO are pleased to explain the emission control system warranty on your 2011 engine. In California, new off-road compression-ignition engines must be designed, built and equipped to meet the State's stringent anti-smog standards. In all states, nonroad compression-ignition engines must be designed, built and equipped to meet the United States EPA emissions standards. HINO must warrant the emission control system on your engine for the periods of time listed below provided there has been no abuse, neglect or improper maintenance of your engine.

Your emission control system may include parts such as the fuel injection system and the air induction system. Also included may be hoses, belts, connectors and other emission-related assemblies.

Where a warrantable condition exists, HINO will repair your off-road compression-ignition engine at no cost to you including diagnosis, parts and labor.

HINO'S WARRANTY COVERAGE:

The 2011 off-road compression-ignition engines are warranted for a period of five years or 3,000 hours of operation, whichever comes first. If any emission-related part on your engine is defective, the part will be repaired or replaced by HINO.

OWNER'S WARRANTY RESPONSIBILITIES:

- As the engine owner, you are responsible for the performance of the required maintenance listed in your owner's manual. HINO recommends that you retain all receipts covering maintenance on your off-road compression-ignition engine, but HINO cannot deny warranty solely for the lack of receipts or for your failure to ensure the performance of all scheduled maintenance.

- As the engine owner, you should however be aware that HINO may deny you warranty coverage if your off-road compression-ignition engine or a part has failed due to abuse, neglect, improper maintenance or unapproved modifications.

- Your engine is designed to operate on diesel only. Use of any other fuel may result in your engine no longer operating in compliance with applicable emissions requirements.
- You are responsible for initiating the warranty process. You must present your engine to a HINO dealer as soon as a problem exists. The warranty repairs should be completed by the dealer as expeditiously as possible.

If you have any questions regarding your warranty rights and responsibilities, you should contact at 1-248-442-6868 (Hino's contact).

EMISSION WARRANTY PARTS:

(1) Fuel Metering System

- (A) Fuel injection system.

(2) Air Induction System

- (A) Intake manifold.
- (B) Turbocharger/Supercharger Systems.
- (C) Charge Air Cooling Systems.

(3) Exhaust Gas Recirculation (EGR) System

- (A) EGR valve body, and carburetor spacer if applicable.
- (B) EGR rate feedback and control system.

(4) Catalyst

(5) Diesel Particulate Control System

Traps, filters, precipitators, and any other device used to capture particulate emissions.

(6) Miscellaneous items Used in Above Systems

- (A) Vacuum, temperature, and time sensitive valves and switches.
- (B) Electronic control units, sensors, solenoids, and wiring harnesses.
- (C) Hoses, belts, connectors, assemblies, clamps, fittings, tubing, sealing gaskets or devices, and mounting hardware.
- (D) Pulleys, belts and idlers.
- (E) Emission Control Information Labels.
- (F) Any other part with the primary purpose of reducing emissions or that can increase emissions during failure without significantly degrading engine performance.