



---

# ***Operation & Maintenance Manual***

*Original Instructions  
Keep this manual with machine at all times.*

## ***Models TL642D, TL943D, TL1055D, TL1255D***

SN ML800150 to Present, SN MLG00150 to Present  
SN MLJ00150 to Present, SN MLD00150 to Present  
SN ML500150 to Present, SN MNT00150 to Present  
SN ML700150 to Present, SN MYW00150 to Present

**31211035  
SEBU9293-05**

*February 18, 2019 - Rev F*

---



## **WARNING**

Operating, servicing and maintaining this vehicle or equipment can expose you to chemicals including engine exhaust, carbon monoxide, phthalates, and lead, which are known to the State of California to cause cancer and birth defects or other reproductive harm. To minimize exposure, avoid breathing exhaust, do not idle the engine except as necessary, service your vehicle or equipment in a well-ventilated area and wear gloves or wash your hands frequently when servicing. For more information go to [www.P65Warnings.ca.gov](http://www.P65Warnings.ca.gov).

## **REVISION LOG**

May 8, 2015 - A - Original Issue of Manual

August 31, 2015 - B - Revised cover and pages d, 2-1, 2-4, 2-5, 2-6, 2-8, 2-9, 2-10, 2-12, 2-13, 2-16, 3-3, 3-5, 3-8, 3-16, 3-17, 4-1, 4-5, 4-7, 5-2, 5-3, 5-35, 5-36, 7-4, -5, 7-7 thru 7-16, 7-19, 7-20, 7-22, 7-23 & 9-1 thru 9-12.

April 10, 2017 - C - Revised pages 1-1, 1-4, 2-5, 2-9 & 5-44.

July 20, 2017 - D - Revised pages b, 1-1, 1-2, 1-4, 1-10, 1-14, 2-1, 2-4 thru 2-16, 2-18, 2-19, 3-3 thru 3-7, 3-9, 3-10, 3-14, 3-18 thru 3-20, 3-25 thru 3-55, 4-4, 4-13, 5-1 thru 5-4, 5-12, 5-26, 5-44, 5-46 thru 5-48, 6-1 thru 6-3, 7-1, 7-3 thru 7-6, 7-8 thru 7-13, 7-24 thru 7-27, 7-29, 7-31 thru 7-33, 8-1, 9-1 thru 9-4, 9-6 & 9-10 thru 9-12.

June 29, 2018 - E - Revised Prop 65

February 18, 2018 - F - Revised pages 2-4, 2-6 thru 2-9, 2-11, 2-13 thru 2-15, 3-4, 4-13, 5-2, 5-3, 5-42, 5-43, 6-1, 7-11, 7-13, 7-24, 9-1, 9-3, 9-6, 9-7 & 9-12.

## ***Read This First***

---

This manual is a very important tool! Keep it with the machine at all times.

The purpose of this manual is to provide owners, users, operators, lessors, and lessees with the precautions and operating procedures essential for the safe and proper machine operation for its intended purpose.

Due to continuous product improvements, the manufacturer reserves the right to make specification changes without prior notification. Contact the local Caterpillar dealer for updated information.

## **Operator Qualifications**

---

The operator of the machine must not operate the machine until this manual has been read, training is accomplished and operation of the machine has been completed under the supervision of an experienced and qualified operator. Operation within the U.S.A. requires training per OSHA 1910.178.

Operators of this equipment must possess a valid, applicable driver's license, be in good physical and mental condition, have normal reflexes and reaction time, good vision and depth perception and normal hearing. Operator must not be using medication which could impair abilities nor be under the influence of alcohol or any other intoxicant during the work shift.

In addition, the operator must read, understand and comply with instructions contained in the following material furnished with the material handler:

- This Operation & Safety Manual
- Telehandler Safety Manual (ANSI only)
- All instructional decals and plates
- Any optional equipment instructions furnished

The operator must also read, understand and comply with all applicable Employer, Industry and Governmental rules, standards and regulations.

## **Modifications**

---

**Modifications to this machine may affect compliance with Industry Standards and/or Governmental Regulations. Any modification must be approved by the manufacturer.**

This product must comply with all safety related bulletins. Contact the local Caterpillar dealer representative for information regarding safety-related bulletins which may have been issued for this product.



**Other Publications Available**

---

Service Manual .....UENR6276 (31211036)

Parts Manual

    TL642D ..... SEBP7604

    TL943D ..... SEBP7603

    TL1055D ..... SEBP7199

    TL1255D ..... SEBP7197

**Note:** *The following standards may be referenced in this manual:*  
*ANSI is compliant to ANSI/ITSDF B56.6*  
*AUS is compliant to AS 1418.19*  
*CE is compliant to EN1459*  
*Refer to the machine Serial Number Plate to identify the applicable compliance standard.*

**This Page Intentionally Left Blank**

---

## TABLE OF CONTENTS

### Revision Log

### Read This First

Operator Qualifications .....	b
Modifications.....	b
Other Publications Available .....	c

### Table of Contents

#### Section 1 - General Safety Practices

1.1 Hazard Classification System .....	1-1
Safety Alert System and Safety Signal Words.....	1-1
1.2 General Precautions .....	1-1
1.3 Operation Safety.....	1-2
Electrical Hazards.....	1-2
Tip Over Hazard.....	1-4
Travel Hazard.....	1-7
Load Falling Hazard .....	1-8
Lifting Personnel.....	1-9
Driving Hazards on Slopes.....	1-10
Pinch Points and Crush Hazards.....	1-11
Fall Hazard.....	1-13
Chemical Hazards .....	1-14
1.4 Product Link (if equipped) .....	1-15
Federal Communications Commission (FCC)	
Information for Users.....	1-15

#### Section 2 - Pre-Operation and Inspection

2.1 Preparation, Inspection and Maintenance.....	2-1
2.2 Pre-Operation Check and Inspection.....	2-2
2.3 Safety Decals .....	2-4
ANSI (if equipped).....	2-4
ISO (if equipped) .....	2-9
2.4 Walk-Around Inspection .....	2-14
2.5 Warm-Up and Operational Checks .....	2-17
Warm-Up Check .....	2-17
Operational Check.....	2-17
2.6 Cab.....	2-18
2.7 Enclosed Cab Windows (if equipped).....	2-19
Cab Door Window .....	2-19
Rear Window .....	2-20

## Table of Contents

---

### Section 3 - Controls and Indicators

3.1	General.....	3-1
3.2	Controls .....	3-2
	Instrument Panel .....	3-4
	LCD Display.....	3-6
	Left Dash Control Panel.....	3-8
	Right Dash Control Panel.....	3-10
	Ignition .....	3-12
	Park Brake .....	3-13
	Parking Procedure.....	3-13
	Transmission Control Lever .....	3-14
	Accessory Control Lever (if equipped).....	3-16
	Outrigger Levers (if equipped) .....	3-17
	Joystick .....	3-18
3.3	Anti-Theft Functionality (if enabled).....	3-20
	Instrument Panel Input .....	3-20
	Multifunction Display Input.....	3-20
3.4	Steer Modes .....	3-21
	Manual Steering Alignment Mode Change .....	3-21
3.5	Operator Seat .....	3-22
	Adjustments .....	3-22
	Seat Belt .....	3-23
3.6	Boom Angle and Extension Indicators.....	3-24
3.7	Reverse Systems (if equipped) .....	3-25
	Reverse Sensing System.....	3-25
	Reversing Camera.....	3-25
3.8	Rear Axle Stabilization (RAS) System .....	3-26
	Free Pivot Mode .....	3-26
	Slow Pivot Mode .....	3-26
	Locked Mode.....	3-26
3.9	Multifunction Display (if equipped) .....	3-27
	General Information .....	3-27
	Multifunction Display and Buttons .....	3-28
	Home Screen.....	3-30
	Main Menu .....	3-32
	Operation and Maintenance .....	3-41
	Troubleshooting .....	3-55

**Section 4 - Operation**

4.1 Engine.....4-1  
    Starting the Engine .....4-1  
    Extreme Cold Weather Starting (if equipped) .....4-2  
    Battery Boosted Starting .....4-3  
    Normal Engine Operation.....4-4  
    Shut-Down Procedure .....4-5  
4.2 Operating with a Non-Suspended Load .....4-6  
    Lift Load Safely.....4-6  
    Picking Up a Load .....4-6  
    Transporting a Load.....4-7  
    Leveling Procedure .....4-7  
    Placing a Load .....4-8  
    Disengaging a Load .....4-8  
4.3 Operating with a Suspended Load .....4-9  
    Lift Load Safely.....4-9  
    Picking Up a Suspended Load.....4-9  
    Transporting a Suspended Load .....4-10  
    Leveling Procedure .....4-10  
    Placing a Suspended Load .....4-11  
    Disengaging a Suspended Load .....4-11  
4.4 Loading and Securing for Transport .....4-12  
    Tie Down .....4-12  
    Lifting .....4-13

# Table of Contents

---

## Section 5 - Attachments

5.1	Approved Attachments .....	5-1
5.2	Unapproved Attachments .....	5-1
5.3	JLG Supplied Attachments .....	5-2
5.4	Telehandler/Attachment/Fork Capacity .....	5-4
5.5	Use of the Capacity Chart .....	5-5
	Capacity Indicator Locations .....	5-5
	Sample Capacity Chart .....	5-6
	Example .....	5-7
5.6	Attachment Installation .....	5-9
	Coupler .....	5-9
	Auxiliary Hydraulic Decompression .....	5-12
5.7	Adjusting/Moving Forks .....	5-13
5.8	Attachment Operation .....	5-14
	Carriage with Forks .....	5-15
	Side Shift Carriage .....	5-16
	Side Tilt Carriage .....	5-18
	Swing Carriage .....	5-20
	Dual Fork Positioning Carriage .....	5-22
	Pipe Grapple .....	5-24
	Fork Extension .....	5-26
	Bucket .....	5-28
	Multipurpose Bucket .....	5-30
	Grapple Bucket .....	5-32
	Trash Hopper - Fork Mounted .....	5-34
	Coupler Mounted Hook .....	5-36
	Fork Mounted Hook .....	5-38
	Truss Boom .....	5-40
	Adjustable Truss Boom - Fork Mounted .....	5-42
	Material Handling Arm .....	5-44
	Personnel Work Platform - Fork Mounted .....	5-46
	Sweeper .....	5-48
	Boom Mounted Lifting Lug .....	5-50

## Section 6 - Emergency Procedures

6.1	Towing a Disabled Product .....	6-1
	Moving Short Distances .....	6-1
	Moving Longer Distance .....	6-1
6.2	Emergency Lowering of Boom .....	6-2
6.3	Emergency Exit from Enclosed Cab .....	6-3
	Inside Cab .....	6-3
	Outside Cab (if equipped) .....	6-3

**Section 7 - Lubrication and Maintenance**

7.1	Introduction .....	7-1
	Clothing and Safety Gear .....	7-1
7.2	General Maintenance Instructions .....	7-2
7.3	Maintenance Schedules .....	7-3
	Every 10 Hours .....	7-3
	First 50 Hours.....	7-3
	Every 50 Hours .....	7-4
	First 250 Hours .....	7-4
	Every 250 Hours.....	7-4
	First 500 Hours or 1 Year .....	7-5
	Every 500 Hours.....	7-5
	Every 750 Hours.....	7-5
	Every 1000 Hours .....	7-6
	Every 1500 Hours .....	7-6
	Every 2000 Hours .....	7-6
7.4	Lubrication Schedules .....	7-8
	Every 50 Hours .....	7-8
	Every 250 Hours.....	7-10
	Every 1000 Hours .....	7-12
7.5	Operator Maintenance Instructions .....	7-14
	Engine Maintenance Components.....	7-14
	Fuel System .....	7-18
	Emission System (SN ML800150 to Present, SN MLJ00150 to Present, SN ML500150 to Present, SN ML700150 to Present).....	7-20
	Engine Oil.....	7-21
	Air Intake System .....	7-22
	Tires.....	7-24
	Transmission Oil .....	7-26
	Hydraulic Oil .....	7-28
	Brake Reservoir Level.....	7-29
	Engine Cooling System.....	7-30
	Windshield Washer System (if equipped) .....	7-31
	Cab Air Filters (if equipped).....	7-32

**Section 8 - Additional Checks**

8.1	General .....	8-1
8.2	Reverse Sensing System (if equipped).....	8-1

**Table of Contents**

---

**Section 9 - Specifications**

9.1 Product Specifications..... 9-1  
    Fluids ..... 9-1  
    Capacities ..... 9-5  
    Tires ..... 9-7  
    Performance ..... 9-8  
    Dimensions ..... 9-10

**Index**

**Inspection, Maintenance and Repair Log**



---

## SECTION 1 - GENERAL SAFETY PRACTICES

---

### 1.1 HAZARD CLASSIFICATION SYSTEM

#### Safety Alert System and Safety Signal Words

---



## DANGER

**DANGER** indicates an imminently hazardous situation which, if not avoided, will result in death or serious injury.



## WARNING

**WARNING** indicates a potentially hazardous situation which, if not avoided, could result in death or serious injury.



## CAUTION

**CAUTION** indicates a potentiality hazardous situation which, if not avoided, may result in minor or moderate injury.

---

### 1.2 GENERAL PRECAUTIONS



## WARNING

Before operation, read and understand this manual. Failure to comply with the safety precautions listed in this manual could result in machine damage, property damage, personal injury or death.

- Hydraulic cylinders are subject to thermal expansion and contraction. This may result in changes to the boom and/or attachment position while the machine is stationary. Factors affecting thermal movement can include the length of time machine is stationary, hydraulic oil temperature, ambient air temperature and boom and/or attachment position.
- Precautions to avoid all hazards in the work area must be taken by the user before and during operation of the machine.

## Section 1- General Safety Practices

### 1.3 OPERATION SAFETY

**Note:** The manufacturer has no direct control over machine application and operation. Therefore, safety issues listed in this manual are non-exhaustive. The user and operator are responsible for conforming with good safety practices.

#### Electrical Hazards

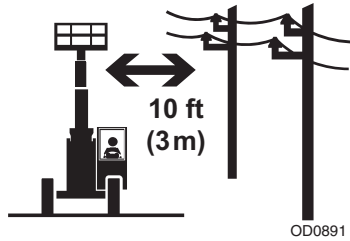
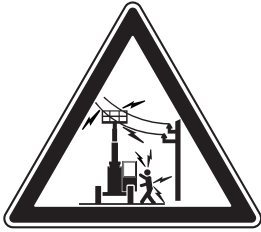

- This machine is not insulated and does not provide protection from contact or being near electrical current.
- Always check for power lines before raising the boom.
- Maintain distance from electrical lines, apparatus, or any energized (exposed or insulated) parts according to the Minimum Approach Distance (MAD).

Voltage Range (Phase to Phase)	Minimum Approach Distance (MAD)
0 to 50 KV	10 ft (3 m)
Over 50KV to 200 KV	15 ft (5 m)
Over 200 KV to 350 KV	20 ft (6 m)
Over 350 KV to 500 KV	25 ft (8 m)
Over 500 KV to 750 KV	35 ft (11 m)
Over 750 KV to 1000 KV	45 ft (14 m)

**Note:** This requirement shall apply except where employer, local or governmental regulations are more stringent.

- Allow for machine movement and electrical line swaying.
- Maintain a clearance of at least 10 ft (3m) between any part of the machine and its occupants, their tools and their equipment from any electrical line or apparatus carrying up to 50,000 volts. One foot additional clearance is required for every additional 30,000 volts or less.

## ***Section 1- General Safety Practices***

---

- The minimum approach distance may be reduced if insulating barriers are installed to prevent contact, and the barriers are rated for the voltage of the line being guarded. These barriers shall not be part of (or attached to) the machine. The minimum approach distance shall be reduced to a distance within the designed working dimensions of the insulating barrier. This determination shall be made by a qualified person in accordance with the employer, local, or governmental requirements for work practices near energized equipment.



**DANGER**

Do not maneuver machine or personnel inside prohibited zone (MAD). Assume all electrical parts and wiring are energized unless known otherwise.

## Section 1- General Safety Practices

### Tip Over Hazard

#### General

- For additional load requirements, refer to the appropriate capacity chart.

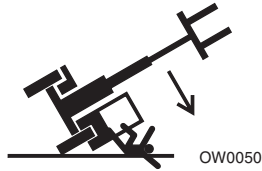

- Never use an attachment without the appropriate original equipment manufacturer (OEM) approved capacity chart installed on the telehandler.
- Understand how to properly use the capacity charts located in cab.
- **DO NOT** exceed rated lift capacity.
- Be sure that the ground conditions are able to support the machine.
- Be aware of wind conditions. Wind may cause load swing and dangerous side loads.
- Keep the machine a minimum of 2 ft (0,6 m) from holes, drop-offs, obstructions, debris, concealed holes and other potential hazards at ground level.

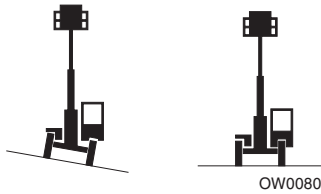
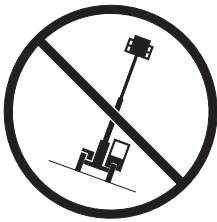

- **DO NOT** raise boom unless frame is level (0 degrees), unless otherwise noted on capacity chart.

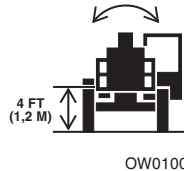
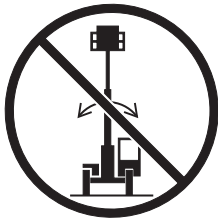

- **DO NOT** level machine with boom/attachment above 4 ft (1,2 m). (AUS - **DO NOT** level machine with load more than 11.8 in (300 mm) above ground surface.)

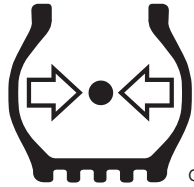

OH2291

- **MAINTAIN proper tire pressure** at all times. If proper tire pressures are not maintained, this machine could tip over.
- Refer to manufacturer's specifications for proper fill ratio and pressure requirements for tires equipped with ballast.



OH20911

- Always wear seat belt.
- Keep head, arms, hands, legs and all other body parts inside operator's cab at all times.



OH2221

If telehandler starts to tip over:

- **DO NOT JUMP**
- **BRACE YOURSELF** and **STAY WITH THE MACHINE**
- **KEEP YOUR SEAT BELT FASTENED**
- **HOLD ON FIRMLY**
- **LEAN AWAY FROM THE POINT OF IMPACT**

## Section 1- General Safety Practices

---

### Non-Suspended Load

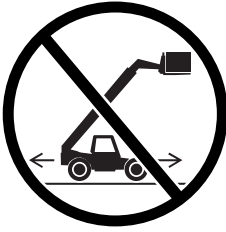

OD0901

- **DO NOT** drive with boom raised.

### Suspended Load

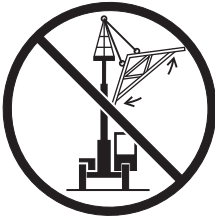

OW0150

- Tether suspended loads to restrict movement.
- Weight of all rigging (slings, etc.) must be included as part of load.
- **DO NOT** attempt to use telehandler frame-leveling to compensate for load swing.
- Keep heavy part of load closest to attachment.
- Never drag the load; lift vertically.

When driving with a suspended load:

- Start, travel, turn and stop slowly to prevent load from swinging.
- **DO NOT** extend boom.
- **DO NOT** raise the load more than 300 mm (11.8 in) above ground surface or the boom more than 45°.
- **DO NOT** exceed walking speed.

### Travel Hazard

2-WHEEL FRONT STEER

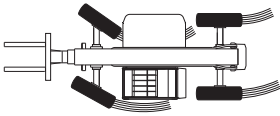

4-WHEEL CIRCLE STEER

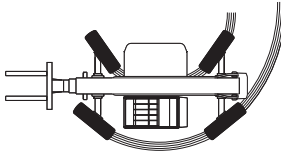

4-WHEEL CRAB STEER

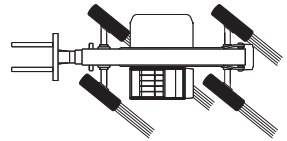

OAL2030

- Steering characteristics differ between steer modes. Identify the steer mode settings of the telehandler being operated.
- **DO NOT** change steer modes while traveling. Steer modes must be changed while telehandler is stationary.
- Visually verify proper wheel alignment after each steer mode change.
- Ensure that adequate clearance is provided for both rear tail swing and front fork swing.
- Look out for and avoid other personnel, machinery and vehicles in the area. Use a spotter if you DO NOT have a clear view.
- Before moving be sure of a clear path and sound horn.
- When driving, retract boom and keep boom/attachment as low as possible while maintaining visibility of mirrors and maximum visibility of path of travel.
- Always look in the direction of travel.
- Always check boom clearances carefully before driving underneath overhead obstructions. Position attachment/load to clear obstacles.
- When driving in high speed, use only front wheel steer (if steering modes are selectable).
- Telehandlers equipped with solid or foam filled tires should not be used in applications requiring excessive roading or driving extended distances. In the event an application requires excessive roading or driving expanded distances, it is recommended to use telehandlers not equipped with solid or foam filled tires.

## Section 1- General Safety Practices

---

### Load Falling Hazard

---

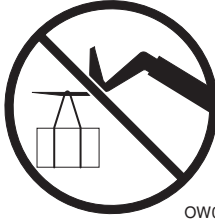

OW0130

- Never suspend load from forks or other parts of carriage weldment. Use only approved lift points.
- **DO NOT** burn or drill holes in fork(s).
- Forks must be centered under load and spaced apart as far as possible.



## Lifting Personnel

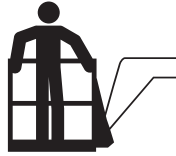

OW0171

- When lifting personnel, **USE ONLY** an approved personnel work platform, with proper capacity chart displayed in the cab.



OD0921

- **DO NOT** drive machine from cab when personnel are in platform.

## Section 1- General Safety Practices

---

### Driving Hazards on Slopes

---

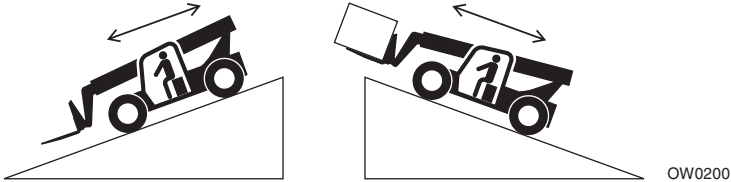

To maintain sufficient traction and braking capabilities, travel on slopes as follows:

- When unloaded, drive with forks pointed downhill.
- When loaded, drive with the forks pointed uphill.
- For additional travel requirements, refer to the appropriate capacity chart.
- To avoid overspeeding the engine and drivetrain when driving down slopes, downshift to a lower gear before going downhill and use the service brake as necessary to maintain a slow speed. **DO NOT shift into neutral and coast downhill.**
- Avoid excessively steep slopes or unstable surfaces. To avoid tip over **DO NOT** drive across excessively steep slopes under *any* circumstances.
- Avoid turning on a slope. Never engage “inching” or shift to “Neutral” when going downhill.
- **DO NOT** park on a slope.

**Pinch Points and Crush Hazards**

Stay clear of pinch points and rotating parts on the telehandler.

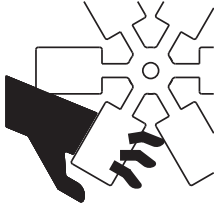

OW0210

- Stay clear of moving parts while engine is running.



OW0220

- Keep clear of steering tires and frame or other objects.



OW0230

- Keep clear from under boom.

## Section 1- General Safety Practices

---



OW0240

- Keep clear of boom holes.



OW0250

- Keep arms and hands clear of attachment tilt cylinder.



OW0260

- Keep hands and fingers clear of carriage and forks.

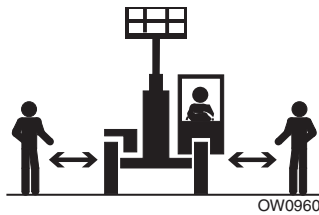

OW0960

- Keep others away while operating.

Fall Hazard



OW0280

- Enter using the proper hand holds and steps provided. Always maintain 3-point contact when mounting or dismounting. Never grab control levers or steering wheel when mounting or dismounting the machine.
- **DO NOT** get off the machine until the shutdown procedure on page 4-5 has been performed.



OW0290

- **DO NOT** carry riders. Riders could fall off machine causing death or serious injury.

## Section 1- General Safety Practices

---

### Chemical Hazards

---

#### Exhaust Fumes

- **DO NOT** operate machine in an enclosed area without proper ventilation.
- **DO NOT** operate the machine in hazardous environments unless approved for that purpose. Sparks from the electrical system and the engine exhaust can cause an explosion.

#### Flammable Fuel



OW0300

- **DO NOT** fill the fuel tank or service the fuel system near an open flame, sparks or smoking materials. Engine fuel is flammable and can cause a fire and/or explosion.

#### Hydraulic Fluid



OW0950

- **DO NOT** attempt to repair or tighten any hydraulic hoses or fittings while the engine is running or when the hydraulic system is under pressure.
- Stop engine and relieve trapped pressure. Fluid in the hydraulic system is under enough pressure that it can penetrate the skin.
- **DO NOT** use your hand to check for leaks. Use a piece of cardboard or paper to search for leaks. Wear gloves to protect hands from spraying fluid.

## **1.4 PRODUCT LINK (IF EQUIPPED)**

### **Federal Communications Commission (FCC) Information for Users**

---

#### **FCC Statement Regarding Interference**

This equipment has been tested and found to comply with the limits for a Class B digital device, pursuant to Part 15 of the FCC Rules. These limits are designed to provide reasonable protection against harmful interference in a residential installation. This equipment generates, uses and can radiate radio frequency energy and, if not installed and used in accordance with the instructions, may cause harmful interference to radio communications. However, there is no guarantee that interference will not occur in a particular installation. If this equipment does cause harmful interference to radio or television reception, which can be determined by turning the equipment off and on, the user is encouraged to try to correct the interference by one or more of the following measures:

- Reorient or relocate the receiving antenna.
- Increase the separation between the equipment and receiver.
- Connect the equipment into an outlet on a circuit different from that to which the receiver is connected.
- Consult the dealer or an experienced radio/TV technician for help.

This device complies with Part 15 of the FCC Rules. Operation is subject to the following two conditions: (1) this device may not cause harmful interference, and (2) this device must accept any interference received, including interference that may cause undesired operation.

Changes or modifications not expressly approved by the party responsible for compliance could void the user's authority to operate the equipment.

## **Section 1- General Safety Practices**

---

### **Notice Regarding Radio Frequency Radiation Exposure**

Do not operate your unit when a person is within eight inches (20 centimeters) of the antenna. A person or object within eight inches (20 centimeters) of the antenna could impair call quality and may cause the unit to operate at a higher power level than necessary, as well as expose that person to RF energy in excess of that established by the FCC RF Exposure Guidelines.

**Important:** The unit must be installed in a manner that provides a minimum separation distance of eight inches (20 centimeters) or more between the antenna and persons and just not be co-located or operate in conjunction with any other antenna or transmitter in order to satisfy FCC RF exposure requirements for mobile transmitting devices.

**Important:** To comply with the FCC RF exposure limits and to satisfy the categorical exclusion requirements for mobile transmitters, the requirements described in the following section, "Antenna Installation", must be met.

### **Antenna Installation**

A minimum separation distance of eight inches (20 centimeters) must be maintained between the antenna and all persons.

The combined cable loss and antenna gain must not exceed +7.5 dBi (850 band). The combined cable loss and antenna gain must not exceed +2.5 dBi and total system output must not exceed 2.0W EIRP in the PCS (1900) band in order to comply with the EIRP limit of 24.232 (b). OEM installers must be provided with antenna installation instruction and transmitter operating conditions for satisfying RF exposure compliance



## **SECTION 2 - PRE-OPERATION AND INSPECTION**

### **2.1 PREPARATION, INSPECTION AND MAINTENANCE**

The following table covers the periodic machine inspections and maintenance required. Consult local regulations for further requirements for telehandlers. The frequency of inspections and maintenance must be increased as necessary when the machine is used in a harsh or hostile environment, if the machine is used with increased frequency, or if the machine is used in a severe manner.

<b>Inspection and Maintenance</b>				
<b>Type</b>	<b>Frequency</b>	<b>Primary Responsibility</b>	<b>Service Qualification</b>	<b>Reference</b>
Pre-Operation Inspection	Beginning of each work shift or at each change of operator.	User or Operator	User or Operator	Operation & Maintenance Manual
Pre-Delivery Inspection (see note)	Before each sale, lease or rental delivery.	Owner, Dealer or User	Qualified Mechanic	Service Manual and applicable Inspection form.
Preventative Maintenance	At intervals as specified in the Service Manual and/or the Maintenance Charts located on the machine.	Owner, Dealer or User	Qualified Mechanic	Service Manual and Maintenance Charts

**Note:** *Inspection forms are available.*

## Section 2- Pre-Operation and Inspection

### 2.2 PRE-OPERATION CHECK AND INSPECTION

**Note:** Complete all required maintenance before operating unit.



## WARNING

**FALL HAZARD.** Use extreme caution when checking items beyond your normal reach. Use an approved ladder.

The pre-operation check and inspection, performed at beginning of each work shift or at each change of operator, should include the following:

1. **Cleanliness** - Check all surfaces for leakage (oil, fuel or battery fluid) or foreign objects. Report any leakage to the proper maintenance personnel.
2. **Structure** - Inspect the machine structure for dents, damage, weld or parent metal cracks or other discrepancies.

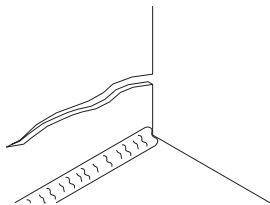

**PARENT METAL CRACK**

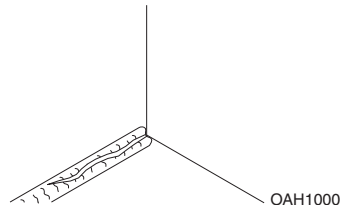

**WELD CRACK**

3. **Safety Decals** - Ensure all safety decals are legible and in place. Clean or replace as required. See page 2-3 for details.
4. **Operation and Safety Manuals** - Operation & Maintenance Manual and AEM Safety Manual (ANSI only) located in cab manual holder.
5. **Walk-Around Inspection** - See page 2-14 for details.
6. **Fluid Levels** - Check fluids, including fuel, diesel exhaust fluid (DEF), hydraulic oil, engine oil and coolant. When adding fluids, refer to Section 7- Lubrication and Maintenance and Section 9- Specifications to determine proper type and intervals. Before removing filler caps or fill plugs, wipe all dirt and grease away from the ports. If dirt enters these ports, it can severely reduce component life.
7. **Attachments/Accessories** - Ensure correct capacity charts are installed on telehandler. If provided, reference Operation & Maintenance Manual of each attachment or accessory installed for specific inspection, operation and maintenance instructions.

## ***Section 2- Pre-Operation and Inspection***

---

- Operational Check** - Once the walk-around inspection is complete, perform a warm-up and operational check (see page 2-17) of all systems in an area free of overhead and ground level obstructions. See Section 3- Controls and Indicators for more specific operating instructions.



## **WARNING**

If telehandler does not operate properly, immediately bring machine to a stop, lower boom and attachment to ground and stop the engine. Determine cause and correct before continued use.



**1001195849 - ENGLISH**  
**1001195851 - ENGLISH/FRENCH**

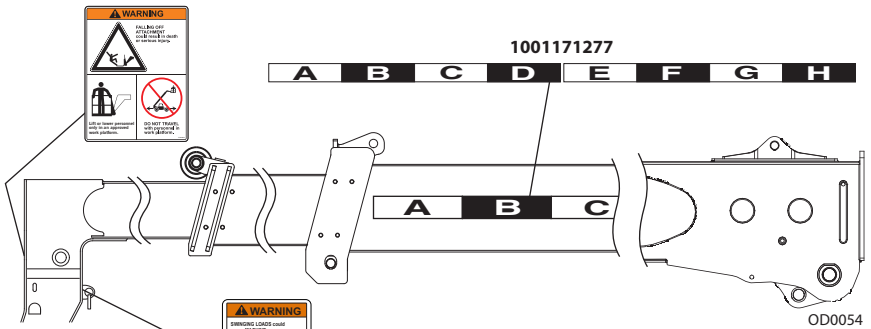

**1001207217 - ENGLISH**  
**1001209625 - ENGLISH/FRENCH**  
**(IF EQUIPPED WITH BOOM MOUNTED LIFTING LUG)**

## Section 2- Pre-Operation and Inspection

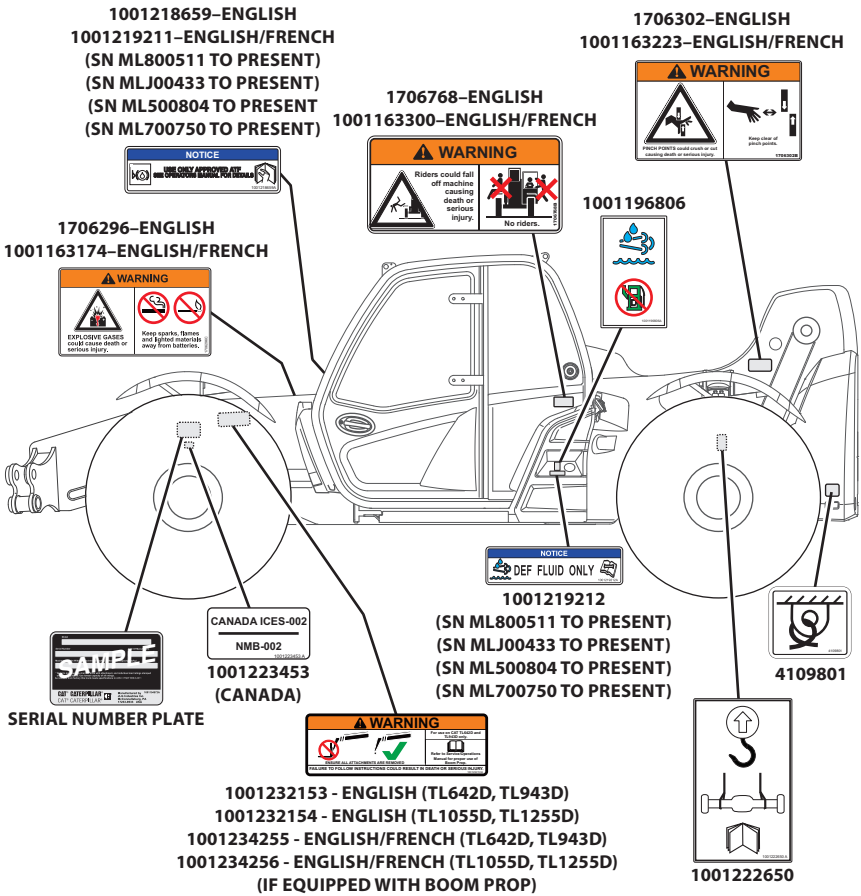

### VIEWS OF FRAME AT FRONT OF MACHINE

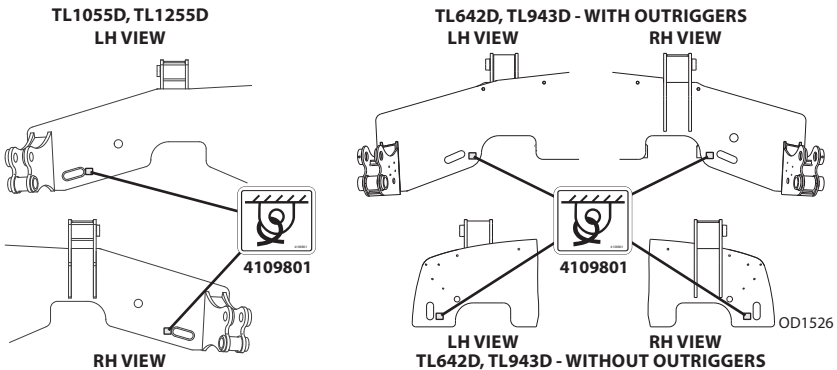

## Section 2- Pre-Operation and Inspection

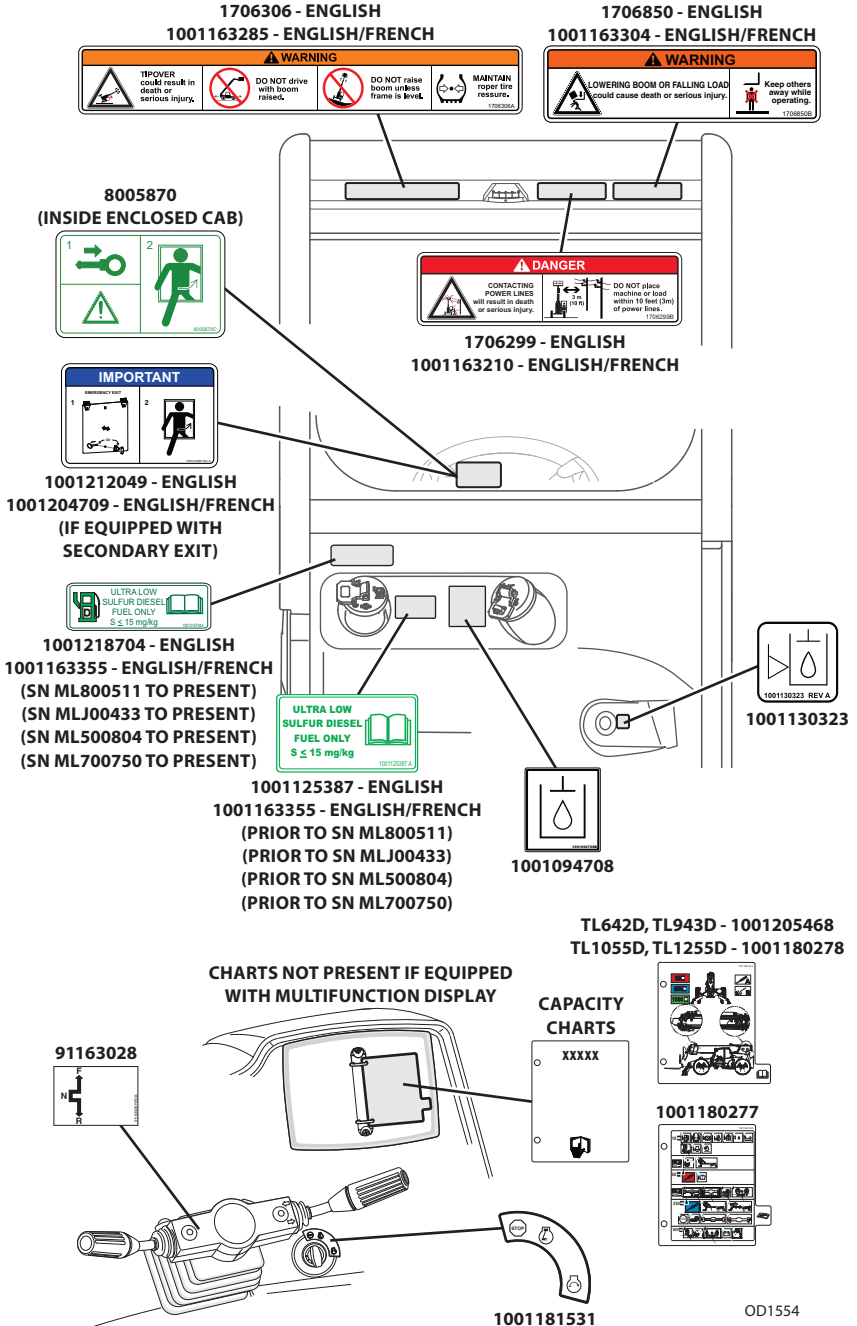

# Section 2- Pre-Operation and Inspection

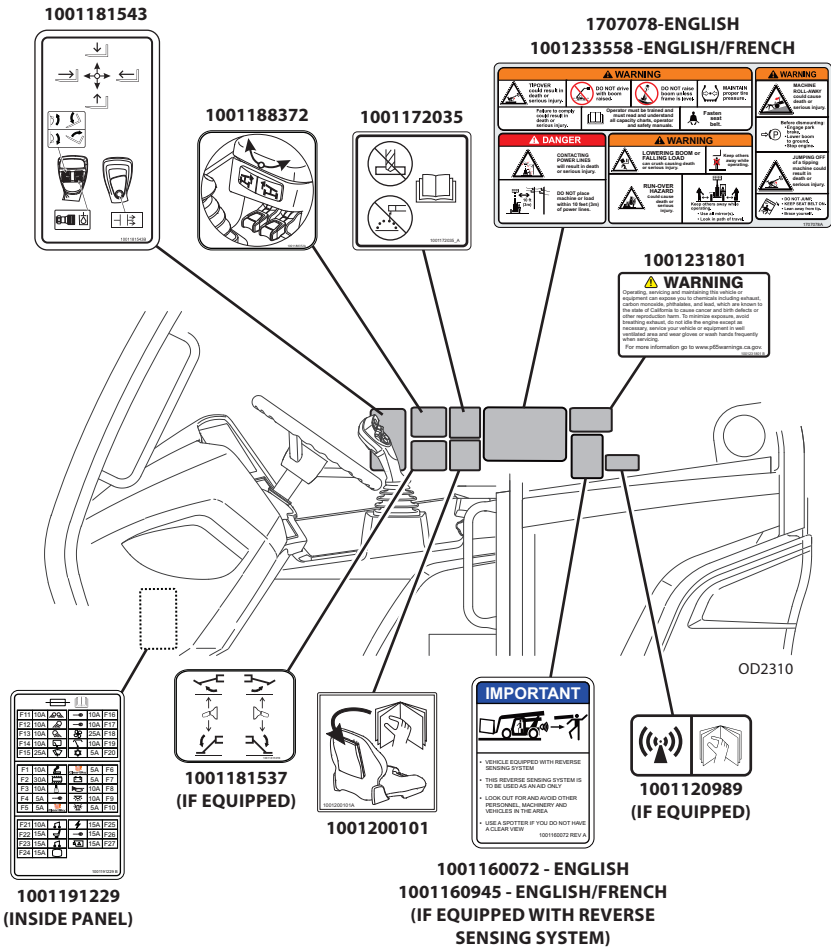



## Section 2- Pre-Operation and Inspection

### ISO (if equipped)

VIEW UNDER ENGINE COVER

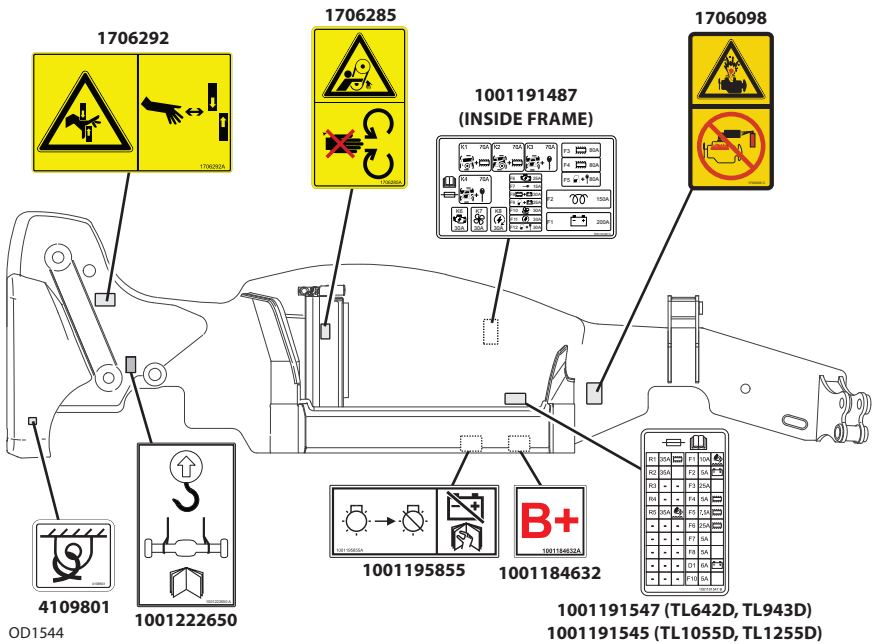
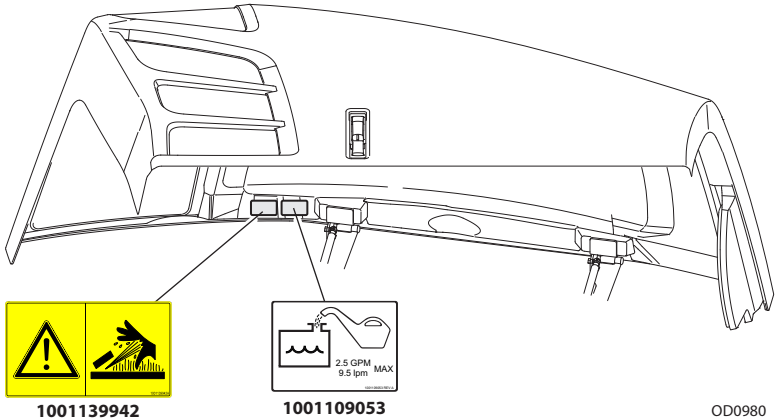

**Section 2- Pre-Operation and Inspection**

---

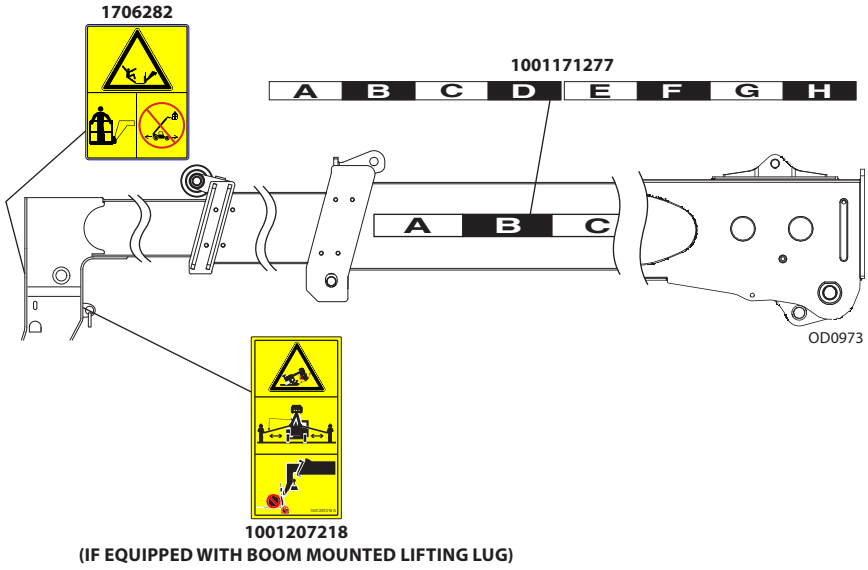

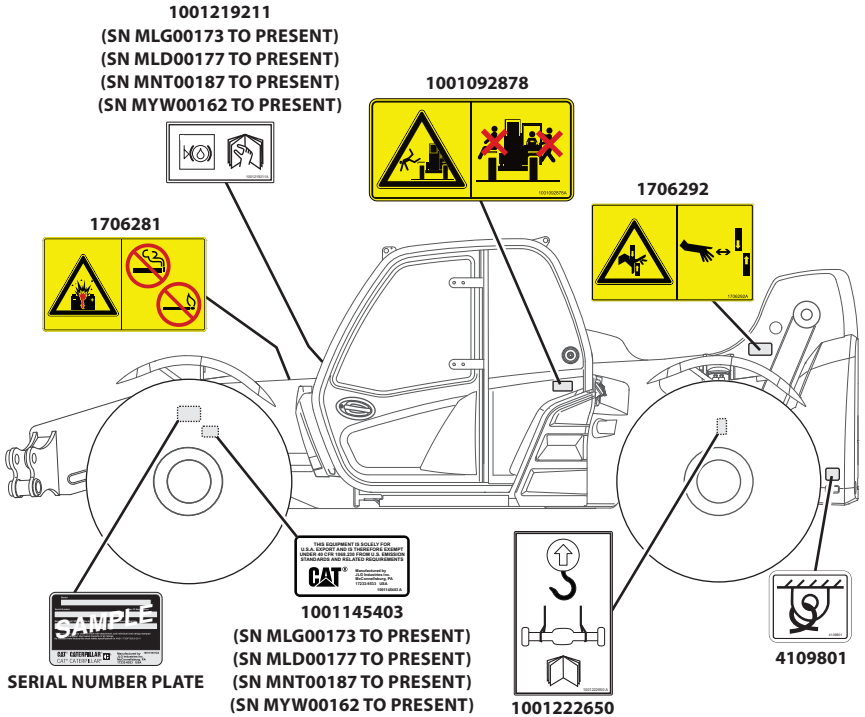

### VIEWS OF FRAME AT FRONT OF MACHINE

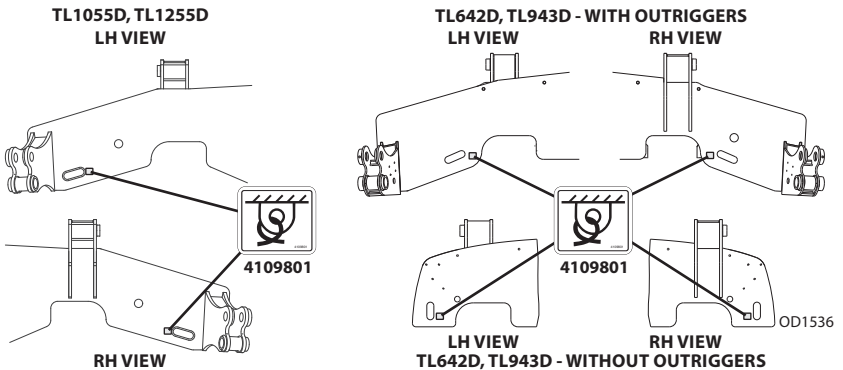

## Section 2- Pre-Operation and Inspection

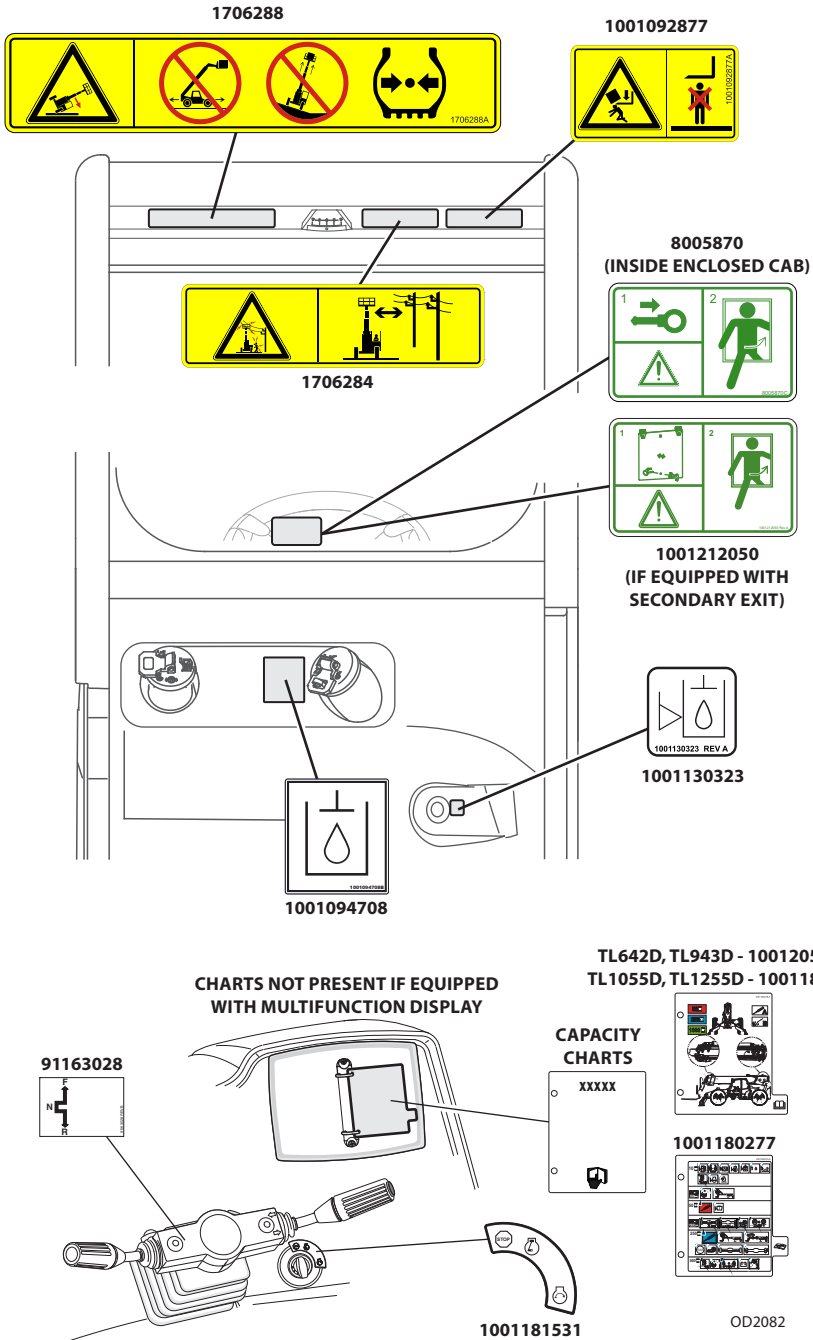

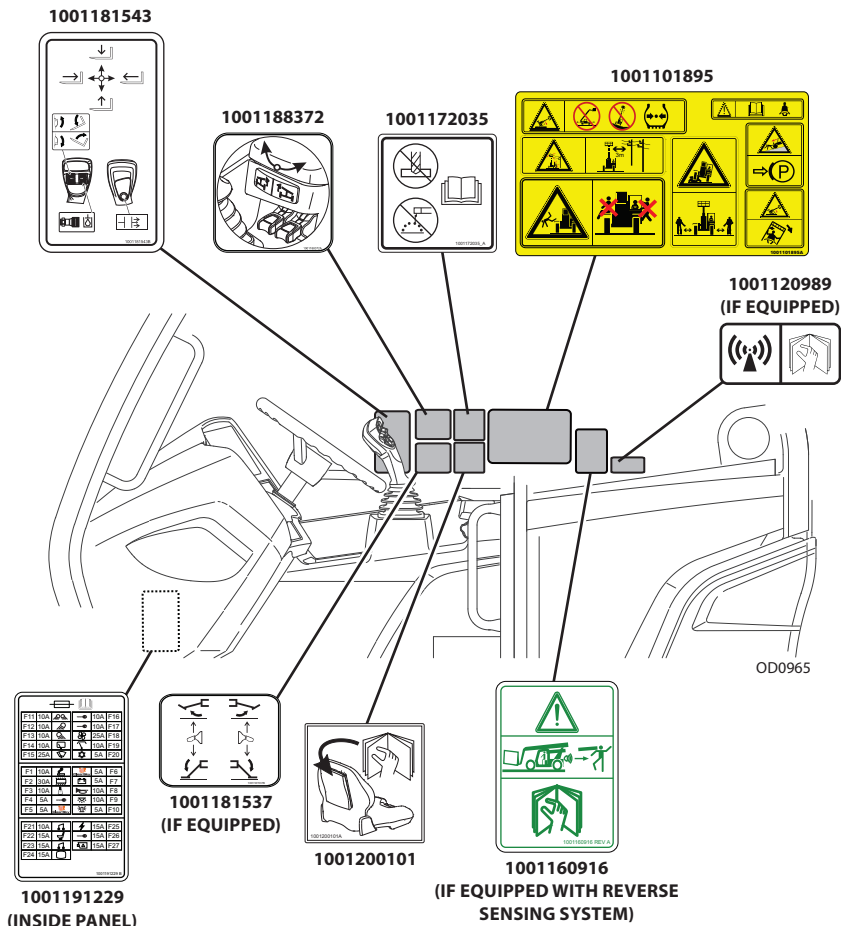

## Section 2- Pre-Operation and Inspection

### 2.4 WALK-AROUND INSPECTION

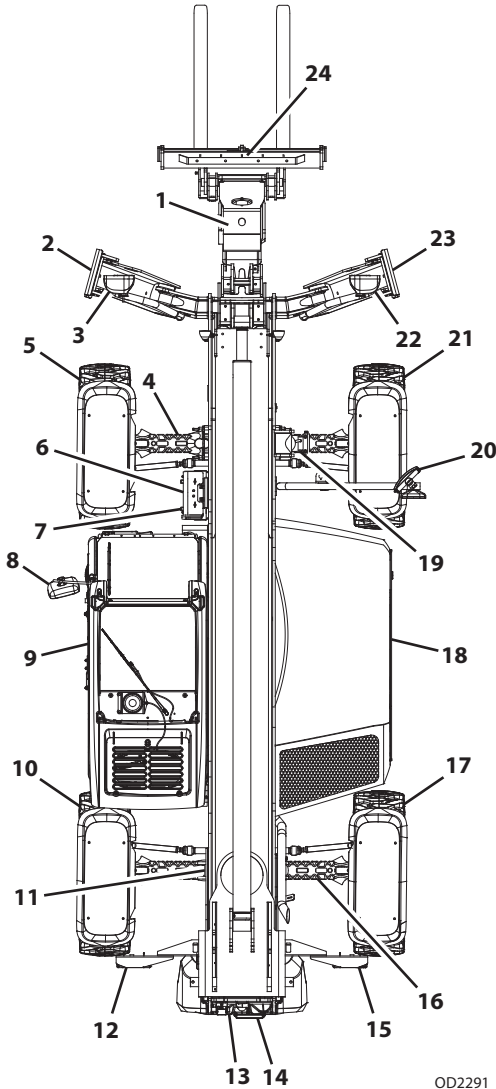

OD2291

Begin your walk-around inspection at item 1, as noted below. Continue to your right (counterclockwise when viewed from top) checking each item in sequence.

**INSPECTION NOTE:** On all components, make sure there are no loose or missing parts, that they are securely fastened and no visible leaks or excessive wear exists in addition to any other criteria mentioned. Inspect all structural members including attachment for cracks, excessive corrosion and other damage.

## **Section 2- Pre-Operation and Inspection**

---

- 1. Boom Sections and Lift, Tilt, Extend/Retract, Compensating Cylinders -**
  - Check front, top, side and rear wear pads for presence of grease.
  - Pivot pins secure; hydraulic hoses undamaged, not leaking.
- 2. Left Outrigger (if equipped) -** Pins secure; hydraulic hoses and cylinder undamaged, not leaking.
- 3. Front Lights (if equipped) -** Clean and undamaged.
- 4. Front Axle -** Steer cylinders undamaged, not leaking; pivot pins secure; hydraulic hoses undamaged, not leaking.
- 5. Wheel/Tire Assembly -** Properly inflated and secured; no loose or missing lug nuts. Inspect for worn tread, cuts, tears or other discrepancies.
- 6. Boom Prop (if equipped) -** See inspection note.
- 7. Wheel Chock (if equipped) -** See inspection note.
- 8. Mirror -** Clean and undamaged.
- 9. Cab and Electrical -**
  - General appearance; no visible damage
  - Frame level indicator(s) and window glass undamaged and clean
  - Gauges, switches, joystick, foot controls and horn operational
  - Check seat belt for damage, replace belt if frayed or cut webbing, damaged buckles or loose mounting hardware
- 10. Wheel/Tire Assembly -** Properly inflated and secured; no loose or missing lug nuts. Inspect for worn tread, cuts, tears or other discrepancies.
- 11. Rear Axle Stabilizer Cylinder -** Pins secure; hydraulic hoses undamaged, not leaking.
- 12. Rear Lights (if equipped) -** Clean and undamaged.
- 13. Reversing Camera (if equipped) -** See inspection note.
- 14. Reversing System (if equipped) -** See inspection note.
- 15. Rear Lights (if equipped) -** Clean and undamaged.
- 16. Wheel/Tire Assembly -** Properly inflated and secured; no loose or missing lug nuts. Inspect for worn tread, cuts, tears or other discrepancies.
- 17. Rear Axle -** Steer cylinders undamaged, not leaking; pivot pins secure; hydraulic hoses undamaged, not leaking.
- 18. Engine Compartment -**
  - Drive belts, check condition and replace as required.
  - Engine mounts - See inspection note.
  - Power Distribution Plate - No damage or corrosion on connections or wiring.
  - Engine cover properly secured.
- 19. Frame Level Cylinder -** Pins secure; hydraulic hose undamaged, not leaking.

## **Section 2- Pre-Operation and Inspection**

---

- 20. Mirror** - Clean and undamaged.
- 21. Wheel/Tire Assembly** - Properly inflated and secured; no loose or missing lug nuts. Inspect for worn tread, cuts, tears or other discrepancies.
- 22. Front Lights (if equipped)** - Clean and undamaged.
- 23. Right Outrigger (if equipped)** - Pins secure; hydraulic hoses and cylinder undamaged, not leaking.
- 24. Attachment** - Properly installed, see "*Attachment Installation*" on page 5-9.



### 2.5 WARM-UP AND OPERATIONAL CHECKS

---

#### Warm-Up Check

---

During warm-up period, check:

1. Heater, air conditioning and wipers (if equipped).
2. Check all lighting systems (if equipped) for proper operation.
3. Adjust mirrors for maximum visibility.



## WARNING

**CUT/CRUSH/BURN HAZARD.** Keep engine cover closed while engine is running except when checking transmission oil level.

#### Operational Check

---

When engine warms, perform an operational check:

1. Service brake and parking brake operation.
2. Forward and reverse travel.
3. Each gear.
4. Steering in both directions with engine at low idle (steering lock to lock will not be reached). Check in each steering mode.
5. Horn and back-up alarm. Must be audible from inside operators cab with engine running.
6. All joystick functions operate smoothly and correctly.
7. Perform any additional checks described in Section 8.

## Section 2- Pre-Operation and Inspection

---

### 2.6 CAB

The telehandler is equipped with an open or enclosed ROPS/FOPS cab.



## WARNING

Never operate telehandler unless the overhead guard, cab structure and right side glass or screen are in good condition. Any modification to this machine must be approved by the manufacturer to assure compliance with ROPS/FOPS certification for this cab/machine configuration. If the overhead guard or cab structure is damaged, the **CAB CANNOT BE REPAIRED**. It must be **REPLACED**.



## WARNING

Never drill, cut, and/or weld to cab. Any modification to this machine must be approved by the manufacturer to assure compliance with machine configuration. If unauthorized drilling, cutting and/or welding is present, the cab must be **REPLACED**.

## **2.7 ENCLOSED CAB WINDOWS (IF EQUIPPED)**

Keep all windows clean and unobstructed.

### **Cab Door Window**

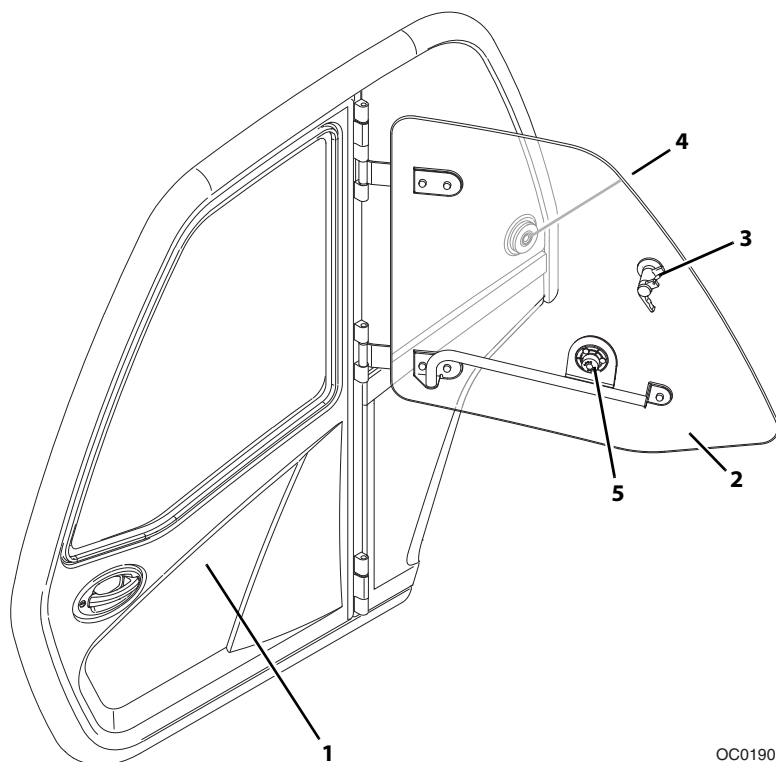

OC0190

- During operation the cab door window (2) must either be latched open or closed
- Open the cab door window using lever (3) and secure it in the latch (4)
- Press release (4) inside cab or (5) outside cab to unlatch window

## **NOTICE**

**EQUIPMENT DAMAGE.** Cab door (1) must be closed during operation. Failure to do so may result in machine damage.

## Section 2- Pre-Operation and Inspection

---

### Rear Window

---

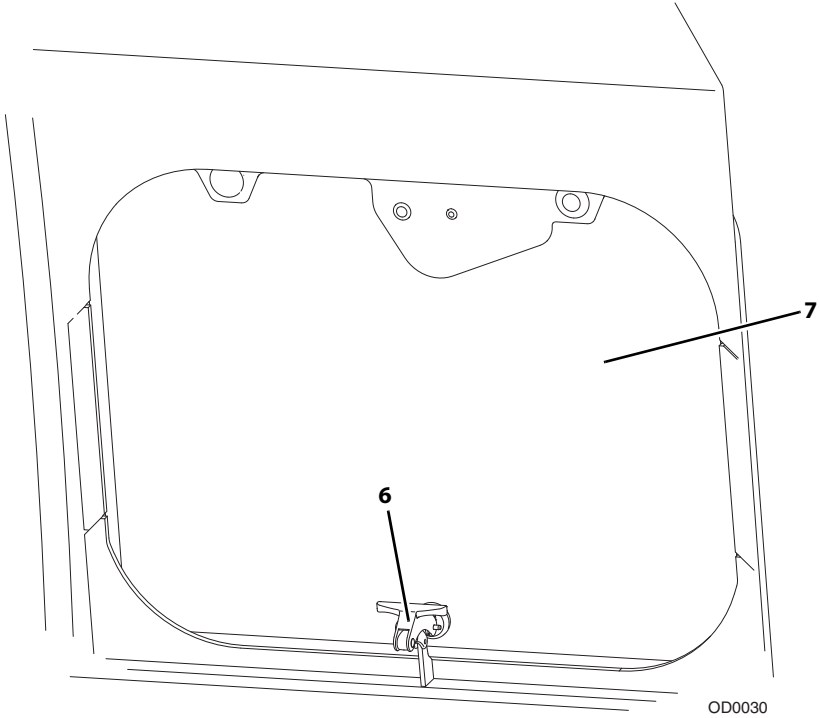

- Lift lever (6) and push to open the rear window (7)
- Lift lever and pull to close

## **SECTION 3 - CONTROLS AND INDICATORS**

---

### **3.1 GENERAL**

This section provides the necessary information needed to understand control functions.

# Section 3- Controls and Indicators

## 3.2 CONTROLS

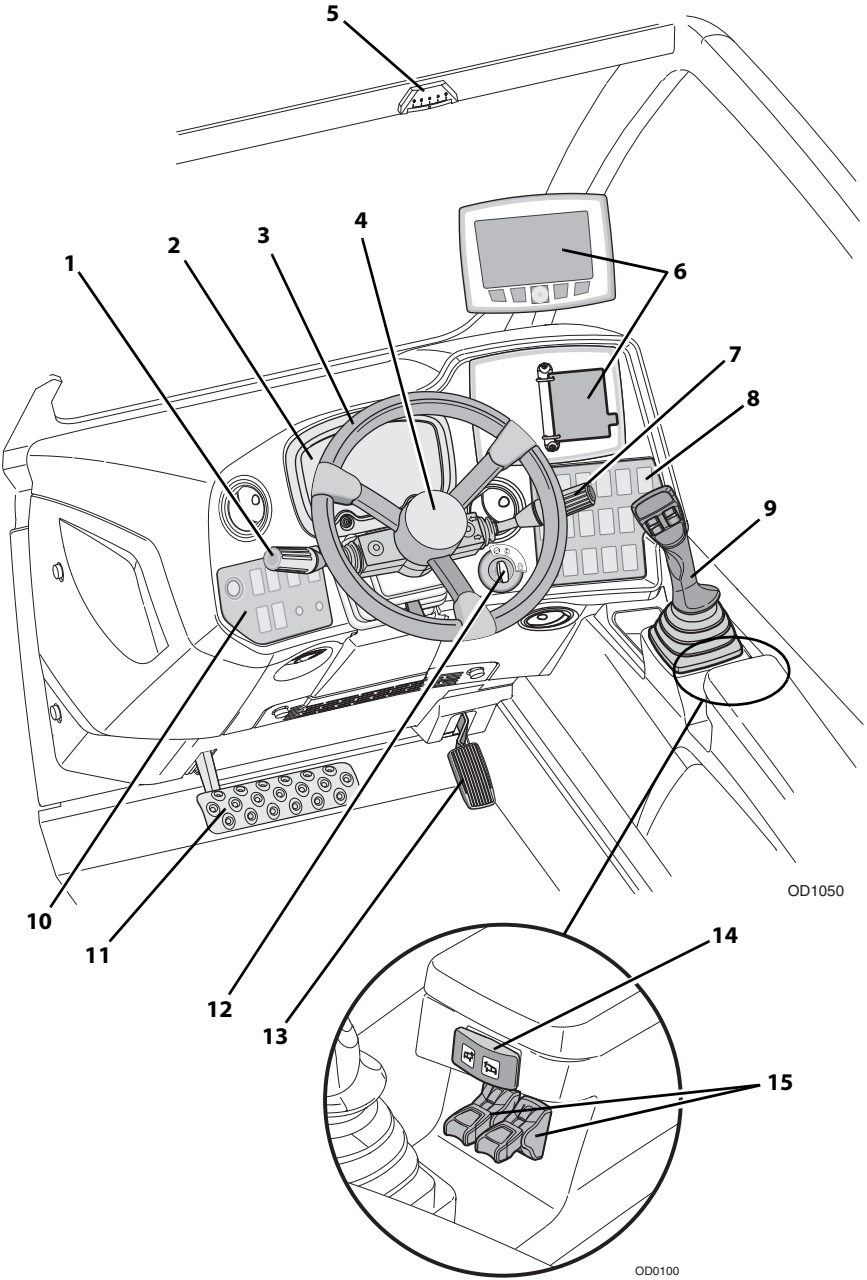

1. **Transmission Control Lever:** See page 3-14.
2. **Instrument Panel:** See page 3-4.
3. **Steering Wheel:** Turning the steering wheel to the left or right steers the machine in the corresponding direction. Three steering modes are available. See "Steer Modes" on page 3-21.
4. **Horn:** Press to sound horn.
5. **Frame Level Indicator:** Enables operator to determine the left to right level condition of the telehandler.
6. **Charts/Display:**
  - a. Capacity and Maintenance Charts (if equipped): See Section 5- Attachments or Section 7- Lubrication and Maintenance.
  - b. Multifunction Display (if equipped): See page 3-20.
7. **Accessory Control Lever (if equipped):** See page 3-16.
8. **Right Dash Control Panel:** See page 3-9.
9. **Joystick:** See page 3-18.
10. **Left Dash Control Panel:** See page 3-8.
11. **Service Brake Pedal:** Further pedal is pressed, the slower the travel speed.
12. **Ignition Switch:** Key activated. See page 3-12.
13. **Accelerator Pedal:** Pressing down the pedal increases engine and hydraulic speed.
14. **Frame Level Switch:** Controls left to right frame level of machine. Press right side of switch to rotate frame right; press left side of switch to rotate frame left.
15. **Outrigger Levers (if equipped):** See page 3-17.

## Section 3- Controls and Indicators

### Instrument Panel

The instrument panel uses different colors to alert the operator to different types of operational situations that could arise.

- When an indicator illuminates RED (except park brake) or if a gauge enters a red zone, immediately bring machine to a stop, lower boom and attachment to the ground and stop the engine. Determine cause and correct before continued use.
- When an indicator illuminates YELLOW an abnormal operating condition is present. If not corrected, machine interruption or damage may result.
- When an indicator illuminates GREEN or BLUE or if a gauge is in the green zone, important information regarding safe operation is being displayed.

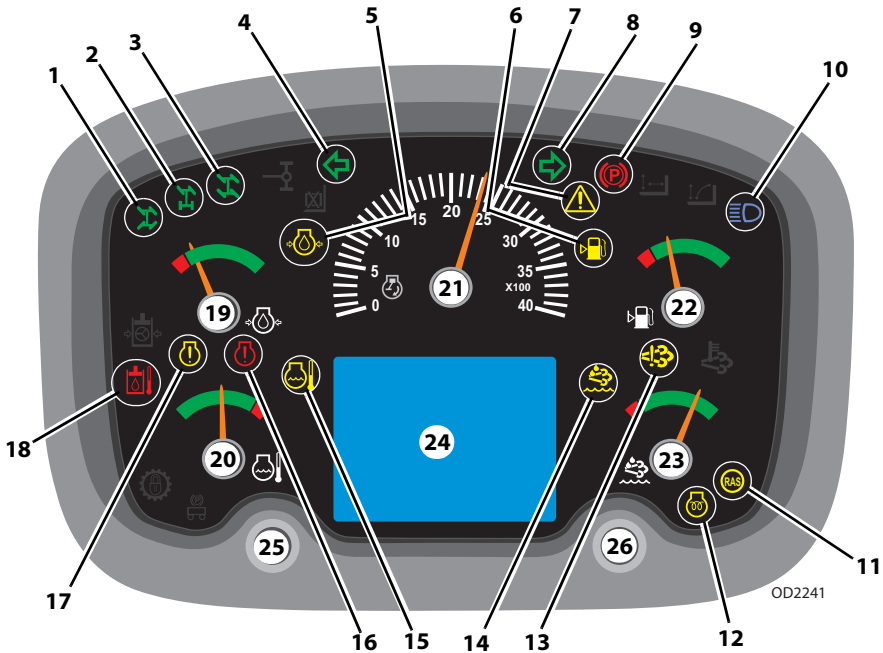

## NOTICE

**EQUIPMENT DAMAGE.** When a red indicator illuminates (except park brake), immediately bring machine to a stop, lower boom and attachment to ground and stop the engine. Determine cause and correct before continued use.

- 1. 4-Wheel Circle Steer:** Illuminates when all wheel steer is active. See page 3-21.
- 2. 2-Wheel Front Steer:** Illuminates when two wheel steer is active. See page 3-21.
- 3. 4-Wheel Crab Steer:** Illuminates when crab steer is active. See page 3-21.



## Section 3- Controls and Indicators

---

4. **Left Turn (if equipped):** Illuminates and flashes when left turn signal or hazard lights are active.
5. **Low Engine Oil Pressure:** Illuminates when oil pressure is low.
6. **Low Fuel Level:** Illuminates when fuel level is low.
7. **System Distress:** Illuminates when critical machine and engine faults exist.
8. **Right Turn (if equipped):** Illuminates and flashes when right turn signal or hazard lights are active.
9. **Park Brake:** Illuminates when park brake is applied. See page 3-13.
10. **High Beam (if equipped):** Illuminates when high beam lights are active.
11. **Rear Axle Stabilization (RAS):** Illuminates when rear axle stabilization is active. See page 3-26.
12. **Engine Preheat:** Illuminates with ignition key in position 1. Indicator goes out when start temperature is reached.
13. **Emissions System (SN ML800150 to Present, SN MLJ00150 to Present, SN ML500150 to Present, SN ML700150 to Present):** Illuminates when an issue exists with the emissions system.
14. **Low Diesel Emission Fluid (DEF) (SN ML800150 to Present, SN MLJ00150 to Present, SN ML500150 to Present, SN ML700150 to Present):** Illuminates when DEF is low.
15. **High Engine Coolant Temperature:** Illuminates when engine coolant temperature is high.
16. **Engine Fault Critical:** Illuminates when critical engine fault exists.
17. **Engine Fault Warning:** Illuminates when engine is operating outside normal range.
18. **High Hydraulic Oil Temperature:** Illuminates when hydraulic oil temperature is high.
19. **Engine Oil Pressure Gauge:** Indicates engine oil pressure.
20. **Engine Coolant Temperature Gauge:** Indicates engine coolant temperature.
21. **Engine Speed:** Indicates engine speed in revolutions per minute (rpm).
22. **Fuel Level Gauge:** Indicates fuel level.
23. **Diesel Emission Fluid (DEF) Level Gauge (SN ML800150 to Present, SN MLJ00150 to Present, SN ML500150 to Present, SN ML700150 to Present):** Indicates fluid level.
24. **LCD Display:** See page 3-6.
25. **Left Control Button** Press to decrease display brightness. Increases digits in anti-theft function. See page 3-20.
26. **Right Control Button** Press to increase display brightness. Confirms digits in anti-theft function. See page 3-20.

## Section 3- Controls and Indicators

### LCD Display

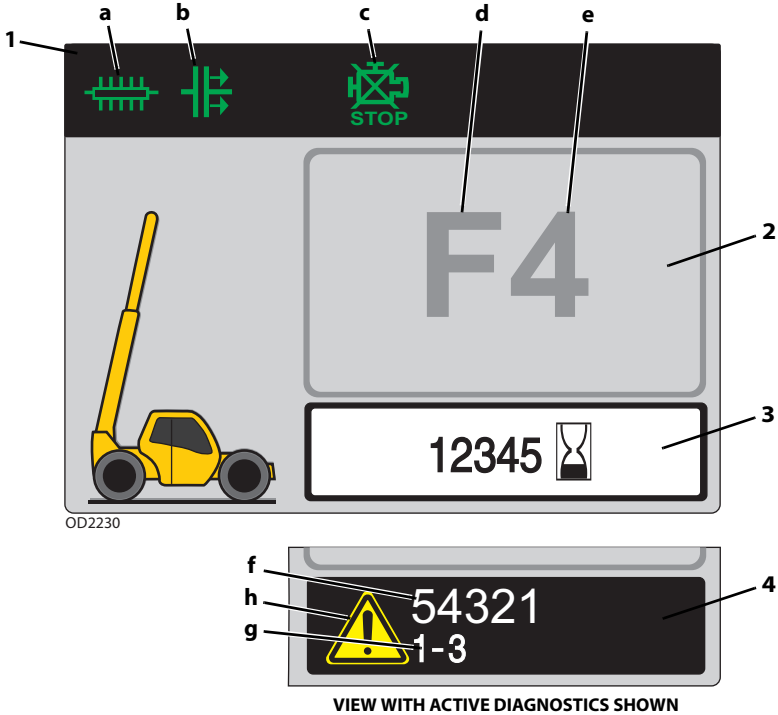

**1. Indicators:** Indicator will display when active.

- a. Continuous Auxiliary Hydraulics - Illuminates when continuous auxiliary hydraulics are active.
- b. Transmission Declutch - Illuminates when transmission declutch function is enabled. See page 3-19.
- c. Do Not Shut Off Engine - Illuminates when stationary exhaust system cleaning is required. See page 4-6.

**2. Driving Direction and Gear:** Displays current driving condition.

- d. Direction - Forward (F), Neutral (N) or Reverse (R).
- e. Gear - First (1), Second (2), Third (3) or Fourth (4).

**3. Operating Hours:** Displays total hours of telehandler operation. Displays when ignition is in ON position and no faults codes exist.



**TRANSMISSION OIL  
TEMPERATURE**



**LOW BATTERY  
INDICATOR**



**SYSTEM DISTRESS  
INDICATOR**



OD2090

**MAINTENANCE  
REQUIRED INDICATOR**

**4. Active Diagnostics:** Displays icon and applicable diagnostic code. Display cycles through each active warning or diagnostic if multiple are present. See Service Manual for details.

f. Fault Code - Displays applicable diagnostic code.

g. Numeric Code Indicator - Displays number of engine fault codes which are present.

h. Diagnostic Icon - Displays diagnostic symbols.

Transmission Oil Temperature Indicator - Illuminates when transmission temperature is high.

Low Battery Indicator - Illuminates when battery is at low charge or charging system is not functioning properly.

System Distress Indicator - Illuminates when critical machine and engine faults exist.

Maintenance Required Indicator - Illuminates when maintenance is required.

## Section 3- Controls and Indicators

### Left Dash Control Panel

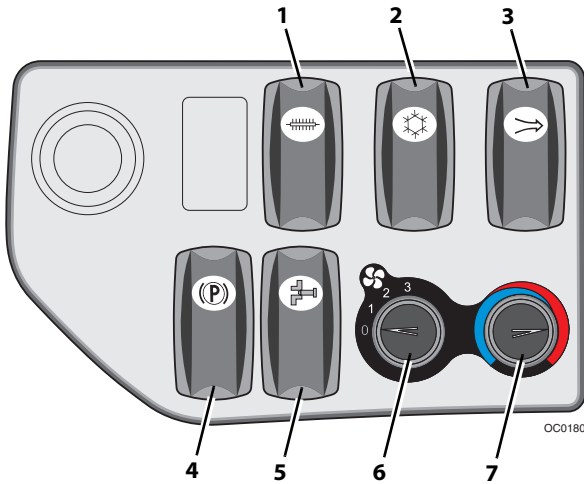

- 1. Continuous Auxiliary Hydraulic Switch (if equipped):** Push for continuous operation of hydraulic powered attachments. See Section 5- Attachments for approved attachments and control instructions.
- 2. Air Conditioning Switch (if equipped):** On/Off switch.
- 3. HVAC Recirculation Switch (if equipped):** On/Off switch. Push to activate and recirculate air inside the cab. While deactivated, air is circulated from outside the cab.
- 4. Park Brake Switch:** On/Off switch. See page 3-13 for details.
- 5. Coupler Switch (if equipped):** Used in conjunction with joystick to hydraulically lock or unlock an attachment. See page 5-11 for details.
- 6. HVAC Fan Speed (if equipped):** Adjustable rotary switch.
- 7. HVAC Temperature Control Switch (if equipped):** Adjustable rotary switch.

**This Page Intentionally Left Blank**

## Section 3- Controls and Indicators

### Right Dash Control Panel

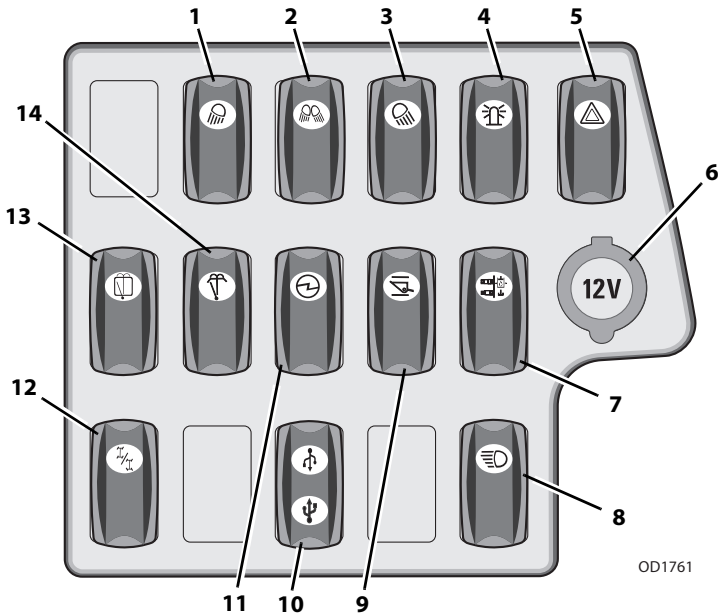

OD1761

1. **Front Work Lights Switch (if equipped):** On/Off switch.
2. **Boom Work Lights Switch (if equipped):** On/Off switch.
3. **Rear Work Lights Switch (if equipped):** On/Off switch.
4. **Beacon Light Switch (if equipped):** On/Off switch.
5. **Hazard Lights Switch (if equipped):** On/Off switch.
6. **Power Outlet (if equipped):** 12V receptacle.
7. **Auxiliary Decompression Switch:** Press to relieve pressure in auxiliary hydraulic circuit. See page 5-12.
8. **Master Light and Road Lights Switch (if equipped):** Three positions: Off, Enable, On. Switch must be in the enable position in order to operate work lights. Prior to machine shut-down, ensure switch is in the off position.
9. **Boom Ride Control Switch (if equipped):** On/Off switch. While enabled and travelling 3 mph (5 kph) or faster, the system acts to improve boom control over rough terrain. Depress switch again to disable boom ride control.
10. **USB Port (if equipped):** USB ports under protective tab.
11. **Auxiliary Electric Switch (if equipped):** On/Off switch.

### **Section 3- Controls and Indicators**

---

- 12. Steer Select Switch:** Three positions: 4-wheel circle steer, 4-wheel crab steer and 2-wheel front steer. See page 3-21.
- 13. Rear Wiper Switch (if equipped):** On/Off switch.
- 14. Roof Wiper Switch (if equipped):** On/Off switch.

## Section 3- Controls and Indicators

---

### Ignition

---

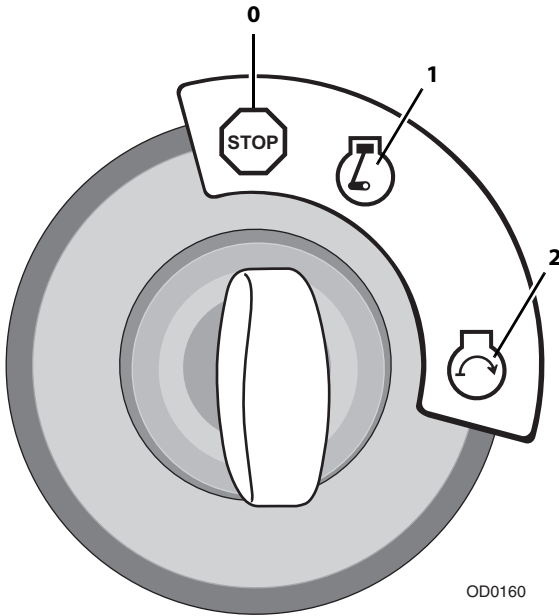

OD0160

- Position **0** - Engine off, no voltage available.
- Position **1** - Voltage available for all electrical functions. Wait to start engine until preheat indicator on instrument panel goes out.
- Position **1** - Engine run.
- Position **2** - Engine start. In the event the engine does not start, rotate key to position 0 then back to position 2 to re-engage the starter.



## Park Brake



ON

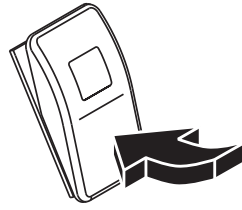

OFF

OD0141

Park brake switch controls the application and release of the park brake.

- With the engine running and the park brake switch in OFF position, park brakes are disengaged.
- With switch in ON position, park brake is engaged and transmission will not engage forward or reverse.



## WARNING

**MACHINE ROLL-AWAY HAZARD.** In the event of engine failure, apply constant pressure to service brake pedal while activating the park brake to the ON position.



## WARNING

**MACHINE ROLL-AWAY HAZARD.** Always move park brake switch to ON position, lower boom to ground and stop engine before leaving cab.



## WARNING

**CRUSH HAZARD.** Turning engine off applies the park brake. Applying park brake or turning engine off while traveling will cause unit to stop abruptly and could cause load loss. Either may be used in an emergency situation.

## Parking Procedure

1. Using service brake, stop telehandler in an appropriate parking area.
2. Follow "Shut-Down Procedure" on page 4-5.

## Section 3- Controls and Indicators

### Transmission Control Lever

#### Direction of Travel Selection

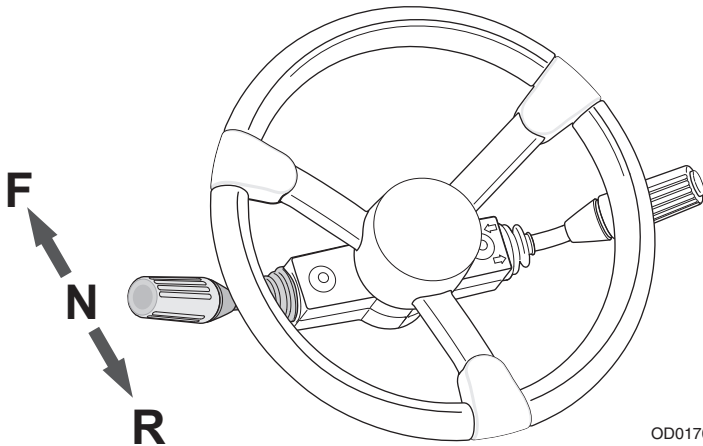

Transmission control lever engages forward or reverse travel.

- Push lever forward for forward travel; pull lever rearward for reverse travel. Move lever to centered position for neutral.
- Forward or reverse travel can be selected while in any gear.
- When traveling in reverse, the back-up alarm will automatically sound.
- Drive in reverse and turn only at slow rates of speed.
- Unless transmission declutch button is activated (see page 3-19), do not increase engine speed with the transmission in forward or reverse and the service brake pressed in an attempt to get quicker hydraulic performances. This could cause unexpected machine movement.



## WARNING

**TIP OVER/CRUSH HAZARD.** Bring telehandler to a complete stop before shifting transmission control lever. A sudden change in direction of travel could reduce stability and/or cause load to shift or fall.

## NOTICE

**EQUIPMENT DAMAGE.** Do not downshift more than one gear at a time. Bring telehandler to a complete stop before shifting transmission into neutral or changing direction of travel. Improper use may result in transmission damage.

### Gear Selection

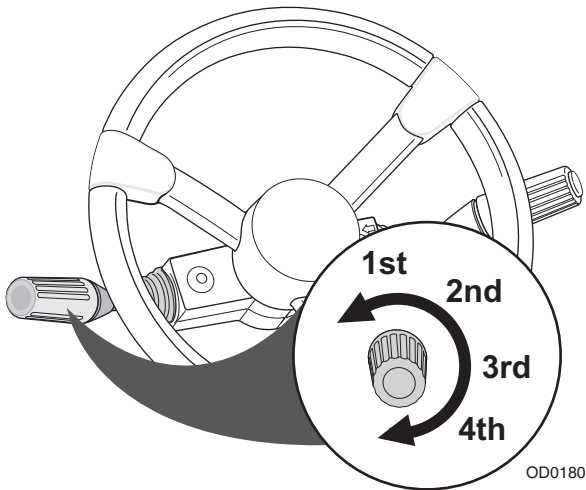

Gear selection is located on the twist grip handle of transmission control lever.

- Twist hand grip to select gear.
- The Transmission is equipped with four forward and three reverse gears.
- Select appropriate gear for task being performed. **Use a lower gear for transporting a load.** Use a higher gear only when driving unloaded for longer distances.
- Slow down prior to downshifting. **Do not downshift more than one gear at a time.**

## Section 3- Controls and Indicators

### Accessory Control Lever (if equipped)

#### Turn Signals and Low/High Beam Headlights

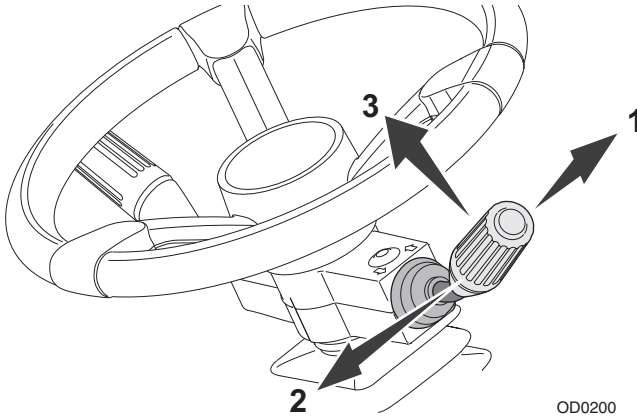

OD0200

- Push accessory control lever forward (1) to activate left turn signal.
- Pull lever backward (2) to activate right turn signal.
- The lever must be manually returned to the center position to deactivate either turn signal. The lever will not cancel automatically after a turn.
- Pull lever up (3) to switch between low and high beam headlights.

#### Front Windshield Wiper

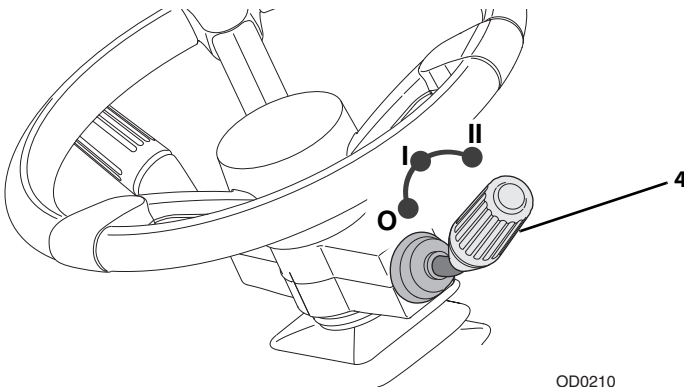

OD0210

- Rotate hand grip (4) to activate front windshield wiper.  
O - Off, I - Continuous or II - Fast.
- Push hand grip (4) towards column to activate windshield wiper fluid.

**Outrigger Levers (if equipped)**

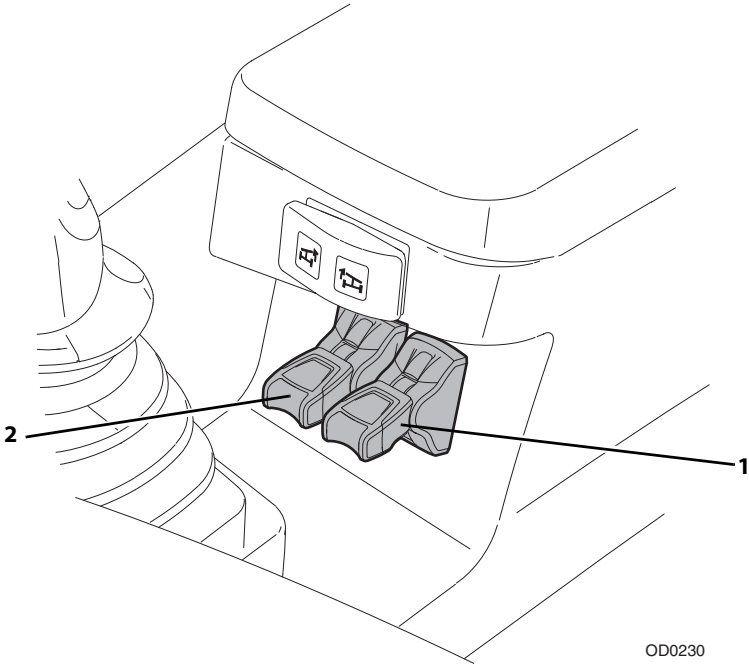

Levers (1 & 2) control the outriggers.

- Left lever (1) controls left outrigger and right lever (2) controls right outrigger.
- Press lever down to lower outriggers.
- Lift lever up to raise outriggers.
- Use the outriggers to increase stability and/or load capacity and in leveling telehandler. Study capacity charts to determine maximum load capacities, with and without outriggers.



**WARNING**

**TIP OVER HAZARD.** Outriggers increase stability and load capacity only if they are used properly. Using outriggers on soft surfaces could cause telehandler to tip over. Always ensure surface can support telehandler and load.

## Section 3- Controls and Indicators

### Joystick

Verify the joystick decal located inside the cab matches the machine controls.

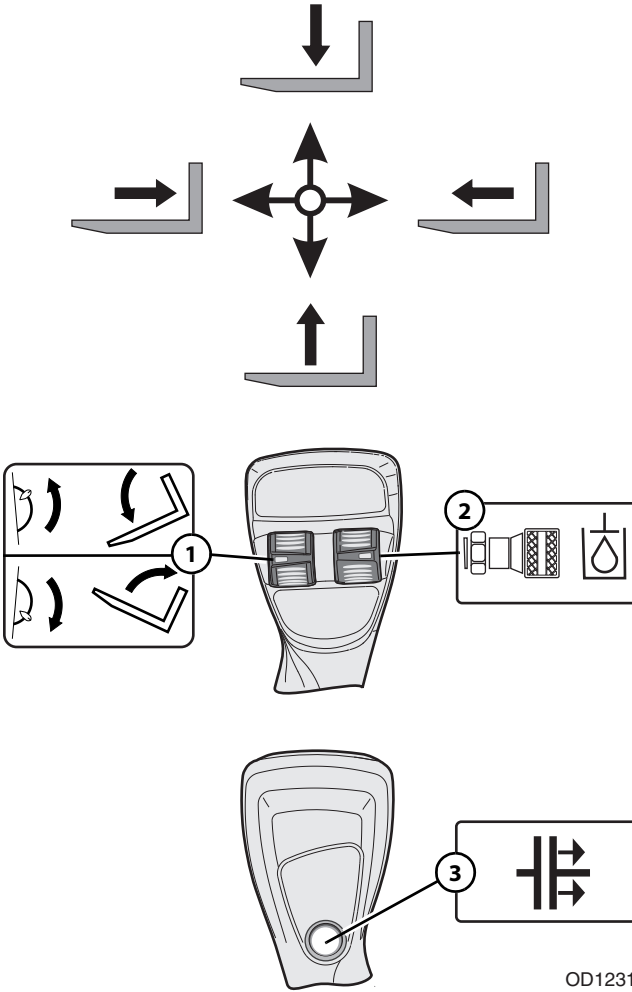

OD1231

The joystick controls the boom, attachment tilt, auxiliary hydraulic and transmission declutch functions.

### Boom Functions

- Move the joystick back to lift boom; move joystick forward to lower boom; move joystick right to extend boom; move joystick left to retract boom.
- The speed of boom functions depends upon the amount of joystick travel in corresponding direction. Increasing engine speed will also increase function speed.
- For two simultaneous boom functions, move joystick between quadrants. For example; moving the joystick forward and to the left will lower and retract boom simultaneously.



## WARNING

**TIP OVER/CRUSH HAZARD.** Rapid, jerky operation of controls will cause rapid, jerky movement of the load. Such movements could cause the load to shift or fall or could cause the machine to tip over.

### Attachment Tilt Function

Attachment tilt is controlled by the roller switch (1).

- Press the roller switch up to tilt attachment down; press the roller switch down to tilt attachment up.

### Auxiliary Hydraulic Functions

The Auxiliary Hydraulics roller switch (2) controls the function of attachments that require the hydraulic supply for operation. See Section 5- Attachments for approved attachments and control instructions.

### Transmission Declutch

Transmission declutch is controlled by button (3).

**Note:** Verify functionality of Transmission Declutch prior to operation.

- While applying service brake, depress and release button to enable transmission declutch function and disengage transmission.  
While applying service brake, depress and release button to disable transmission declutch function and engage transmission.
- (TL1055D, TL1255D Early Production Only) Apply service brake. Depress and hold button to enable transmission declutch function and disengage transmission. Release button or release service brake to disable transmission declutch function and engage transmission.

## Section 3- Controls and Indicators

---

### 3.3 ANTI-THEFT FUNCTIONALITY (IF ENABLED)

Machines with anti-theft feature active require entering a numeric code before operation to prevent unauthorized use. If multifunction display is installed, anti-theft feature is accessed from that display only.

**Note:** If the anti-theft feature is active and the current access code is not known, it may be viewed or changed by the machine owner (level 2 password may be required). See Service Manual for information.

#### Instrument Panel Input

---

Code entry is accomplished using information provided in the instrument panel display.

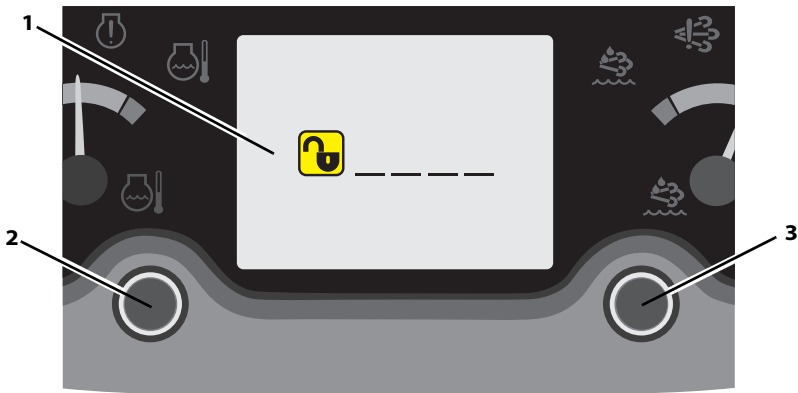

OD1240

1. Turn ignition switch to position 1. If anti-theft is active, the display (1) will prompt the operator for a numeric code.
2. Use the left button (2) to select the first digit. Press button to increase number. Number will increase from 0 thru 9 then roll over to 0.
3. Press the right button (3) to confirm current digit and move to the next digit.
4. Continue until the code is complete.
5. If an incorrect code is entered, the display will prompt the operator again for the numeric code.
6. If the correct code is entered, normal start up can continue.

#### Multifunction Display Input

---

If machine is equipped with Multifunction Display, refer to page 3-41 for anti-theft functionality information.



### 3.4 STEER MODES

Three steer modes are available for operator use.

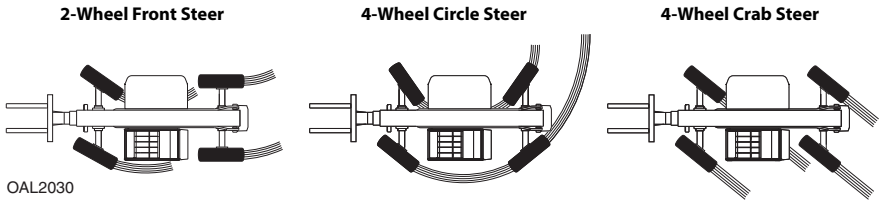

**Note:** 2-Wheel Front Steer mode is required for travel on public roads.

### Manual Steering Alignment Mode Change

**Note:** Steer mode will change immediately after selection.

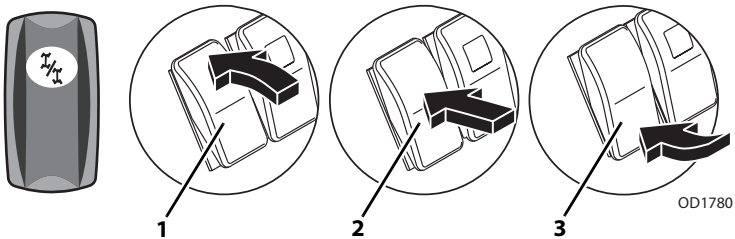

1. Bring machine to a stop using service brake. If front steer mode (2) is active and rear wheels are aligned, go directly to step 4.

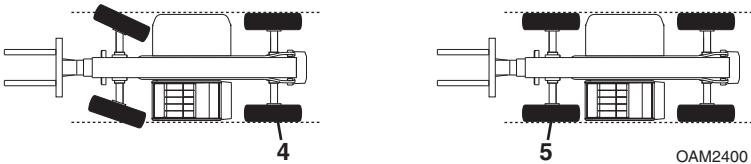

2. With circle steer (1) or crab steer (3) mode active, turn the steering wheel until the left rear wheel (4) is aligned with the side of the machine.
3. Select front steer mode (2).
4. Turn the steering wheel until the left front wheel (5) is aligned with the side of the machine.
5. Wheels are now aligned. Select desired steer mode.

## Section 3- Controls and Indicators

---

### 3.5 OPERATOR SEAT

#### Adjustments

---

Prior to starting the engine adjust seat for position and comfort.

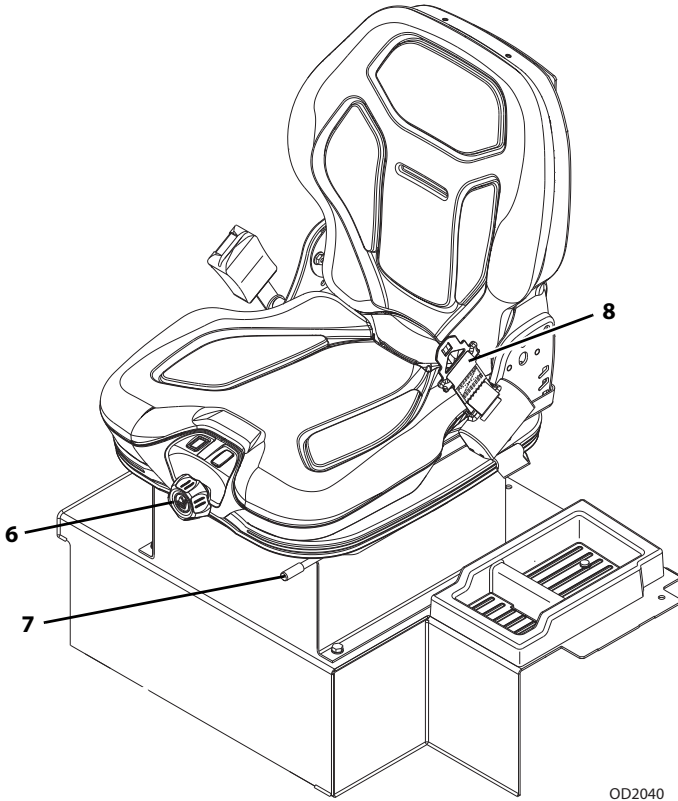

OD2040

1. **Suspension:** Use the knob (6) to adjust the suspension to appropriate weight setting.
2. **Fore/Aft:** Use lever (7) to move seat fore and aft.
3. **Seat Belt:** Always fasten seat belt (8) during operation.

**Seat Belt**

---



Fasten seat belt as follows:

1. Grasp both free ends of the belt making certain that belt webbing is not twisted or entangled.
2. With back straight in the seat, couple the retractable end (male end) of the belt into the receptacle (buckle) end of the belt.
3. With belt buckle positioned as low on the body as possible, pull the retractable end of the belt away from the buckle until it is tight across the lap.
4. To release belt latch, press red button on the buckle and pull free end from buckle.

## Section 3- Controls and Indicators

---

### 3.6 BOOM ANGLE AND EXTENSION INDICATORS

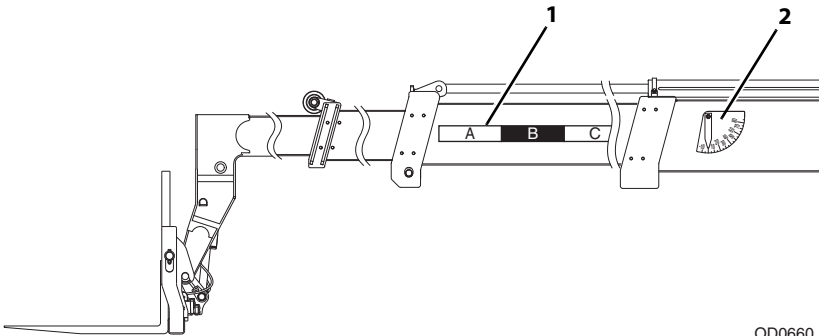

- The boom extension indicators (1) are located on the left side of the boom. Use these indicators to determine boom extension when using the capacity chart (see *“Use of the Capacity Chart”* on page 5-5).
- The boom angle indicator (2) is located on the left side of the boom. Use this indicator to determine the boom angle when using the capacity chart (see *“Use of the Capacity Chart”* on page 5-5).

---

### 3.7 REVERSE SYSTEMS (IF EQUIPPED)



## WARNING

**CRUSH HAZARD.** Running into persons or objects can cause death, serious injury, or damage to property and equipment. Always check mirrors and area behind vehicle before and when backing up. Reverse systems are for supplementary use only.

---

### Reverse Sensing System

The reverse sensing system provides audible indication of objects to rear of unit while in reverse gear.

- Alarm sounds signaling machine is placed in reverse gear.

**Note:** *Reverse Sensing System detects objects larger than 36 square inches (232.25 square centimeters) area and is functional when machine is moving in reverse direction.*

- No alarm when detection zone is clear of objects.
- Pulsing alarm sounds when an object is in range of Reverse Sensing System. Alarm increases in frequency as object becomes closer.
- If alarm sounds at a frequency of eight pulses per second (8 Hz) an object is detected within 5 feet (1.5 m). Stop reverse direction of machine by applying service brake. Perform “*Shut-Down Procedure*” on page 4-5. Check and clear area behind machine of objects before proceeding in a reverse direction.

---

### Reversing Camera

If machine is equipped with Multifunction Display, refer to page 3-25 for reversing camera information.

## Section 3- Controls and Indicators

---

### 3.8 REAR AXLE STABILIZATION (RAS) SYSTEM

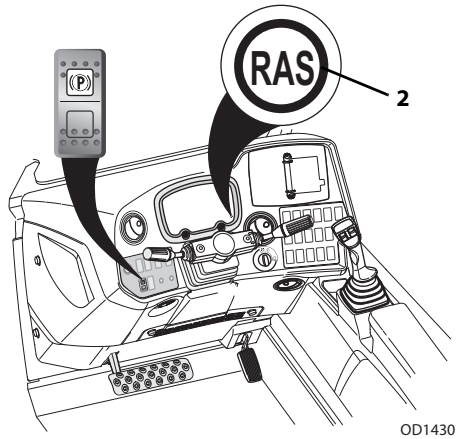
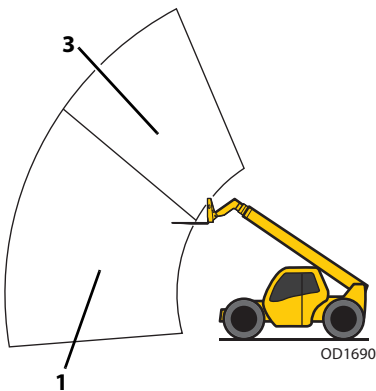

#### Free Pivot Mode

---

With boom below 40° (1), RAS system is in Free Pivot Mode. Rear axle pivots freely and frame level functions normally. RAS indicator (2) will be off.

#### Slow Pivot Mode

---

With boom above 40° (3), the RAS system is in Slow Pivot Mode when service brake is not applied and transmission is in gear. Rear axle will respond slowly to changes in terrain and frame level functions normally. RAS indicator (2) will be off.

#### Locked Mode

---

With boom above 40° (3), and activating one or more of following functions, RAS system is in Locked Mode.

- Park brake switch engaged
- Transmission control lever in Neutral
- Service brake pedal depressed

The RAS indicator (2) will illuminate when in lock mode. When the rear axle is locked, if frame level or outriggers functions are operated, the rear axle goes into Slow Pivot Mode.

### 3.9 MULTIFUNCTION DISPLAY (IF EQUIPPED)

#### General Information

This section provides the necessary information needed to understand the multifunction display.

#### Start of Multifunction Display

The multifunction display will be active when the ignition is in position 1.



OAP0320

After the multifunction display has been powered on, the machine brand logo (1) will be displayed briefly followed by the home screen.

**Note:** If anti-theft is active, the display will prompt the operator for a numeric code. See page 3-41 for procedure.

## Section 3- Controls and Indicators

### Multifunction Display and Buttons

**Note:** Apply park brake to access the Attachment Selection and Main Menu buttons.



**1. Display:** The display shows the following depending on selection.

- Anti-theft. See page 3-41.
- Home screen. See page 3-30.
- Reversing camera (if equipped). See page 3-44.
- Advanced diagnostics. See page 3-33.
- Maintenance charts. See page 3-45.
- Lubrication charts. See page 3-47.
- Personalities screen: Personalities menu displays various electrically controlled parameters that drive the hydraulic functions related to outriggers, frame level, boom lift, extend/retract and auxiliary. See Service Manual for more personalities information.
- Operator tools screen. See page 3-38.
- Calibration screen. See page 3-39.

**2. Previous Screen Button:** The previous screen button returns the display to the previous menu or screen. The screen will not change if already at the home screen.



- 3. Attachment Select Button:** The attachment selection button allows the operator to select a specific attachment in order to display the applicable capacity chart. See page 3-42.
- 4. Navigation Button:** The navigation button has four arrow buttons to navigate up, down, left or right. The center button allows the operator to confirm the selection.
- 5. Main Menu Button:** The main menu button displays the main menu. The operator can navigate the menu using the navigation button. See page 3-32.
- 6. Home Screen Button:** The home screen button returns display to the home screen. The screen will not change if already at the home screen.

## Section 3- Controls and Indicators

### Home Screen

The home screen displays at the successful startup or when the Home Screen button is selected.

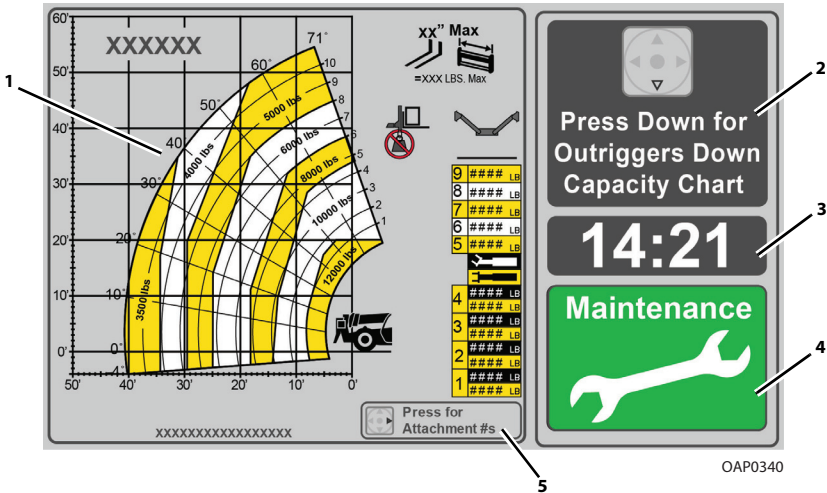

- 1. Capacity Chart:** The capacity chart is displayed based on the selected attachment, and if equipped, selected outriggers position. See page 3-42 for capacity chart selection and page 5-5 for use of the capacity chart.

**Note:** If the display does not have capacity charts, see Service Manual for troubleshooting.

- 2. Outriggers Position (if equipped):** Outriggers position allows the operator to select the current outriggers position. Appropriate capacity chart will display based on the selected outriggers position. See page 3-43.

**Note:** If machine is not equipped with outriggers, the outriggers position will be blank.

- 3. Real-Time Clock (RTC):** The real-time clock displays the time in 12 or 24 hour format.
- 4. Maintenance Status:** The maintenance status icon shows the current status of maintenance and notifies the operator if any maintenance activity is required. See page 3-36.

- Green: No scheduled maintenance required.
- Yellow: Scheduled maintenance required. See page 3-45.

**Note:** Brand logo is displayed when the maintenance status is not enabled.

**5. Attachment Part Numbers:** Press right Navigation button to display the list of OEM supplied attachment part numbers. Part numbers display for 3 seconds, then home screen displays.

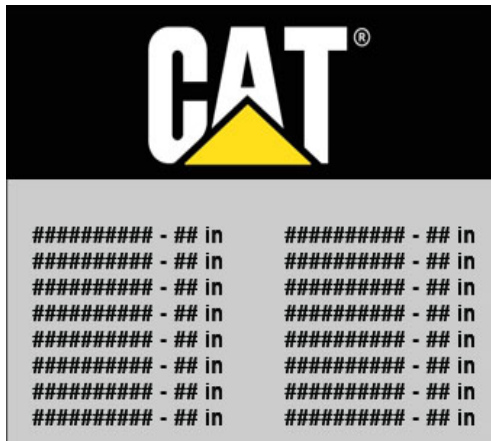

OAP0350

## Section 3- Controls and Indicators

---

### Main Menu

---

Press the Main Menu button to access the main menu.

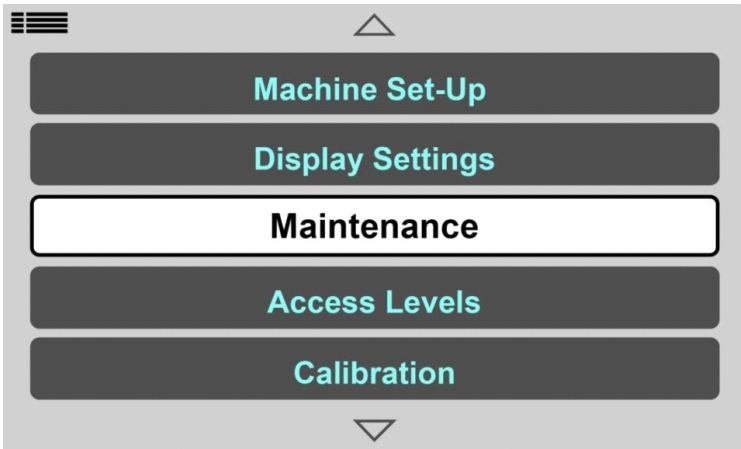

OAP0050

**Note:** Scroll up or down to view all items.

#### Maintenance

Maintenance menu displays the maintenance intervals and lubrication requirements to properly maintain the telehandler.

**Maintenance Intervals:** Maintenance intervals allow the operator to view all the unique maintenance tasks required when engine hours reach an identified interval or multiples of the intervals. See page 3-45.

**Lubrication:** Lubrication allows the operator to view lubrication charts. See page 3-47.

#### Access Level

The access level screen displays the current access level. Code entry determines access level.

- Operator (Level 3) - No code required.
- Customer (Level 2) - See Service Manual.
- Service (Level 1) - Manufacturer service representative only.

### Advanced Diagnostics

Advanced diagnostics menu allows the operator to view diagnostic information.

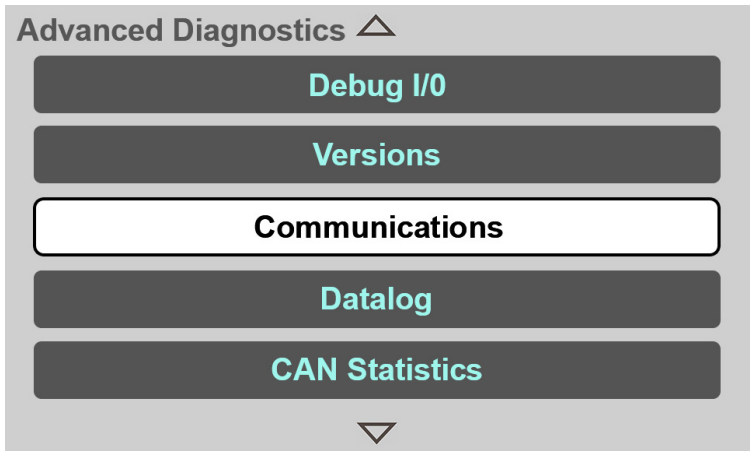

OAP0060

**Communications:** Communications screen displays the status of all CAN modules in the control system. The status of the appropriate module will be RED in color if there is any CAN loss. If the communication is good, the appropriate module status will be GREEN in color.

**Versions:** Versions screen displays the version of the software, hardware and constant data of control modules in the machine.

**Debug I/O:** Debug I/O screen displays the status of all inputs/outputs and assigned machine function name for the cabin control module, front frame facing control module, and rear frame facing control modules.

**Engine:** Engine screen displays parameters related to engine.

**Joystick:** Joystick screen displays parameters related to the joystick.

**Transmission:** Transmission screen displays parameters related to the drive or transmission.

**Hydraulics:** Hydraulics screen displays parameters related to the outriggers, frame level and cabin functions.

**Calibration Data:** Calibration data screen displays calibration values for all calibrated sensors in the control system.

**System:** System screen displays parameters related to control system.

**Drive/Steer:** Drive/Steer screen displays parameters related to steering system.

**Lights:** Lights screen displays parameters related to lighting.

### ***Section 3- Controls and Indicators***

---

**Boom Ride & Float:** Boom ride and float screen displays parameters related to boom ride and float.

**CAN Statistics:** CAN statistics screen displays the parameters of the system bus and diagnostic bus.

### Display Settings

Display settings menu allows the operator to set up the Real-Time Clock (RTC) and screen brightness. Additionally, the operator can view the language settings, maintenance status icon (enable/disable) and revision number of library files.

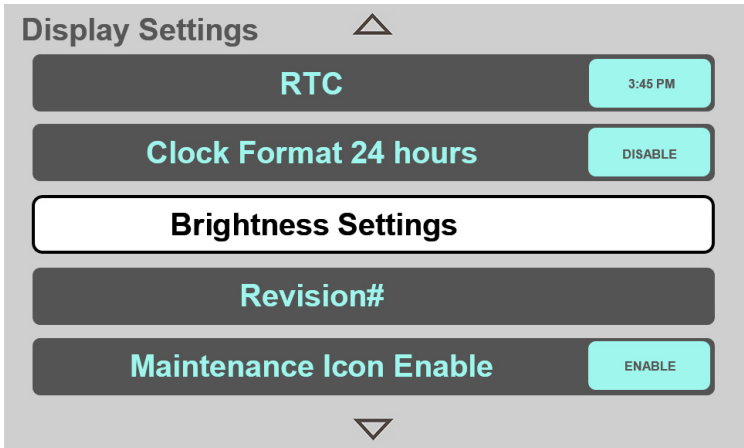

OAP0070

**Brightness Settings:** Brightness settings menu allows the operator to adjust the screen brightness. It consists of following features to adjust the screen brightness.

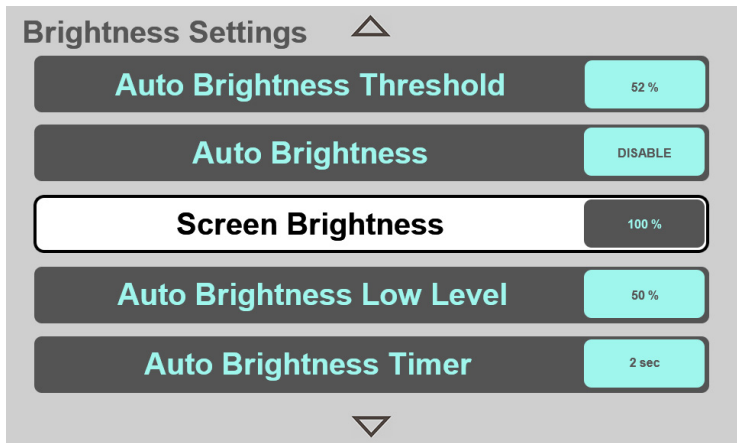

OAP0080

- Screen Brightness:** Screen brightness allows the operator to adjust the screen brightness (0 - 100% in 1% increment).
- Auto Brightness:** Auto brightness screen allows the operator to set auto brightness to enable or disable mode.

## Section 3- Controls and Indicators

---

- c. **Auto Brightness Threshold:** Auto brightness threshold allows the operator to adjust the auto brightness threshold value when auto brightness is enabled. Based on ambient light level and auto brightness threshold, display will set to auto brightness low level or screen brightness.
- d. **Auto Brightness Timer:** Auto brightness timer allows the operator to adjust the length of time to change to appropriate brightness when auto brightness is enabled.
- e. **Auto Brightness Low Level:** Auto brightness low level allows the operator to set the preferred lowest brightness level (in %) when auto brightness is enabled.

**Clock Format 24 Hours:** Clock format screen allows the operator to set the real-time clock in 12 or 24 hour format.

**Real-Time Clock (RTC):** Real-time clock screen allows the operator to set hours, minutes, day, month and year by the use of navigation button.

**Language:** Language allows the operator to view the current language. See Service Manual to change current language.

**Maintenance Icon Enable:** Maintenance icon enable screen allows the operator to set the maintenance status to enable or disable mode on the home screen.

**Revision#:** Revision# screen displays the revision numbers of all libraries (capacity and maintenance chart) and application.

**Competitive Coupler:** Competitive coupler screen allows the operator to show or hide competitive coupler attachments in the attachment selection menu when a competitive coupler is fitted.



### Machine Set-Up

Machine set-up menu displays configuration (brand, model, engine and transmission etc.) of the machine.

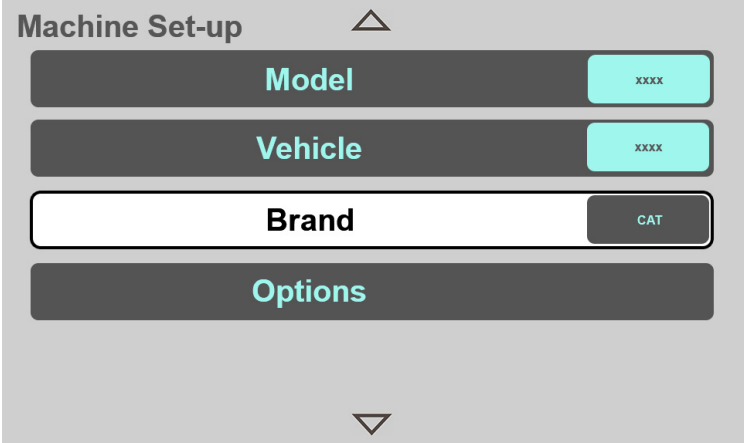

The screenshot shows a 'Machine Set-up' menu with four main sections: 'Model', 'Vehicle', 'Brand', and 'Options'. Each section has a corresponding input field. The 'Model' and 'Vehicle' fields are dark grey with light blue text and light blue input boxes containing 'XXXX'. The 'Brand' field is white with black text and a dark grey input box containing 'CAT'. The 'Options' field is dark grey with light blue text and no input box. The menu is framed by a grey border with an upward-pointing triangle at the top and a downward-pointing triangle at the bottom.

OAP0360

**Brand:** Brand displays brand name of the machine.

**Vehicle:** Vehicle displays the type of vehicle based on boom configuration and market preferences.

**Model:** Model displays machine model.

**Options:** Options screen provides machine configuration details for transmission, engine control, auxiliary functions and all other controls.

## Section 3- Controls and Indicators

---

### Operator Tools

Operator tools menu allows the operator to set various machine settings.

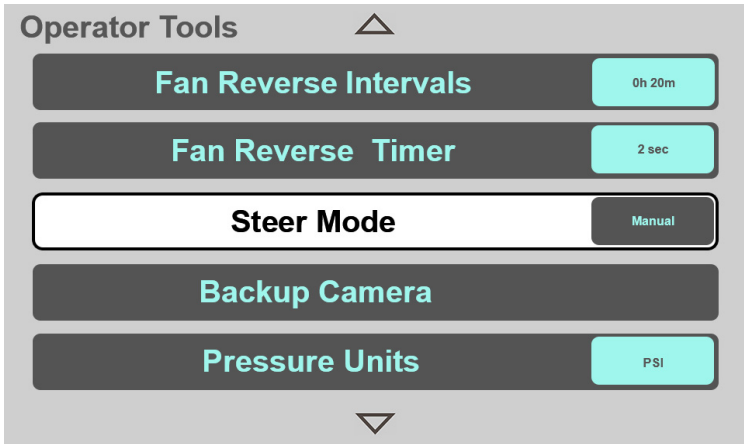

OAP0100

**Steer Mode:** Steer mode allows the operator to select desired steer mode.

- Manual steer mode
- Automatic steer mode (not utilized on current model)

**Fan Reverse Timer:** Not utilized on current model.

**Fan Reverse Interval:** Not utilized on current model.

**Default Gear:** Not utilized on current model.

**Elevated Idle:** Elevated idle allows the operator to set the elevated idle.

**Vehicle Speed Units:** Not utilized on current model.

**Temperature Units:** Temperature units allows the operator to set the units for temperature in Fahrenheit (F) or Celsius (C).

**Pressure Units:** Pressure units allows the operator to set the units for pressure in PSI or BAR.

**Backup Camera (if equipped):** Backup camera allows the operator to temporarily view the area behind the telehandler on the home screen.

### Calibrations

Calibrations menu allows the operator to perform functionality checks for various machine controls.

- Park brake test. See page 3-51.
- See Service Manual for more calibrations information.

### Error Messages (Fault Codes)

Error messages screen allows the operator to view up to 25 recently logged Diagnostic Trouble Code (DTC)/Diagnostics Message 1 (DM1) fault codes along with a text description. The fault codes are displayed in the order in which they are received. Active fault codes are shown with an asterisk symbol. See Service Manual for additional fault code information.

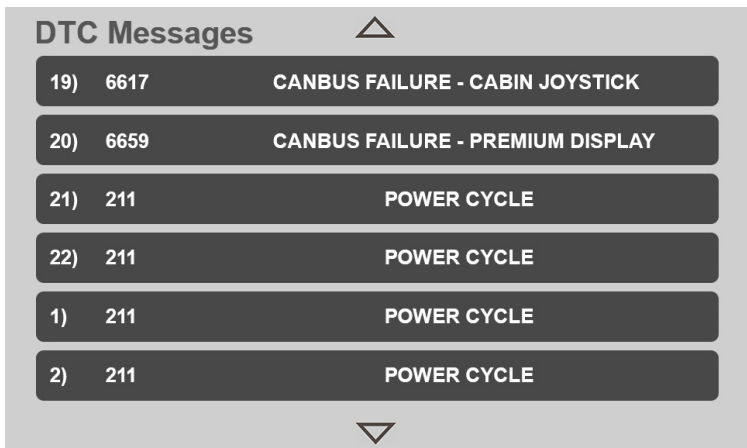

OAP0110

**DTC Messages:** DTC messages display all machine related fault codes. The DTC message consists of a three to five digit number and corresponding message.

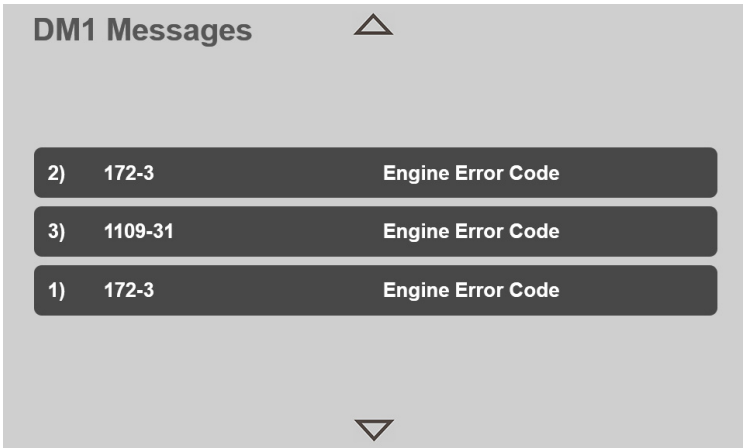

OAP0120

**DM1 Messages:** DM1 messages display all engine related fault codes. The DM1 message consists of the Suspect Parameter Number (SPN) and Fault Mode Indicator (FMI) component.

### Operation and Maintenance

#### Anti-Theft Functionality

Machines with anti-theft feature active require entering a numeric code before operation to prevent unauthorized use. If multifunction display is installed, anti-theft feature is accessed from that display only.

**Note:** If the anti-theft feature is active and the current access code is not known, it may be viewed or changed by the machine owner. See Service Manual.

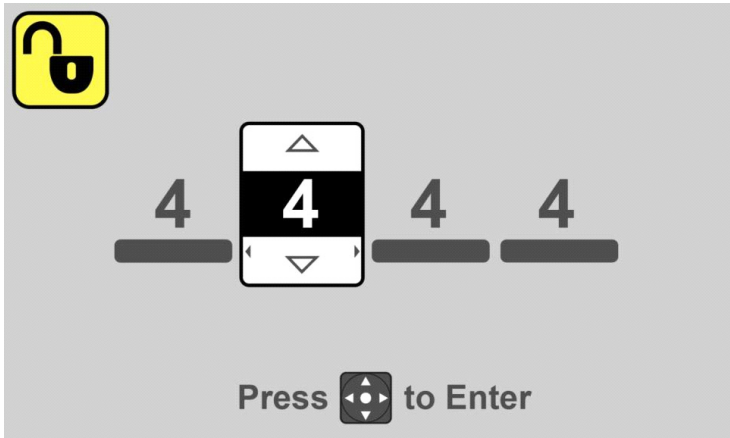

OD1920

1. Turn ignition switch to position 1. If anti-theft is active, the display will prompt the operator for a numeric code.
2. Press the up/down arrows of the Navigation button to select the first digit.
3. Press the right arrow of the Navigation button to move to the next digit.
4. Continue until the code is complete. Press the center of the Navigation button to confirm the code.
5. If an incorrect code is entered, the display will prompt the operator again for the numeric code.
6. If the correct code is entered, normal start up can continue.

## Section 3- Controls and Indicators

### Capacity Chart Selection

The home screen displays proper capacity chart based on the selected attachment, and if equipped, selected outriggers position.

#### A. Attachment Selection

The attachment selection button allows the operator to select a specific attachment in order to display the applicable capacity chart.

1. Press the Attachment Select button to access the types of attachments.

**Note:** The Competitive Coupler type is only visible when enabled. See "Display Settings" on page 3-35.

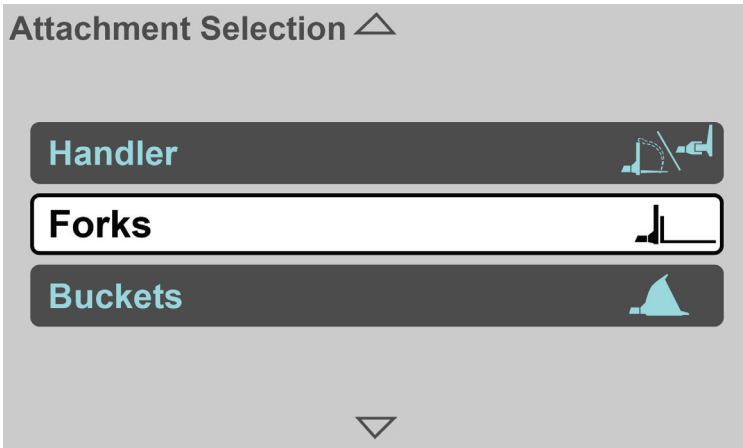

OAP0130

2. Select the type of attachment.

**Note:** Scroll up or down to view all items.

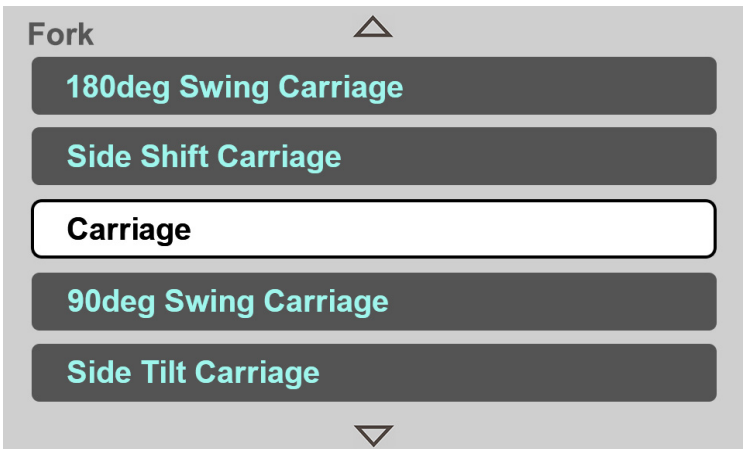

OAP0140

3. Select the specific attachment to be used.

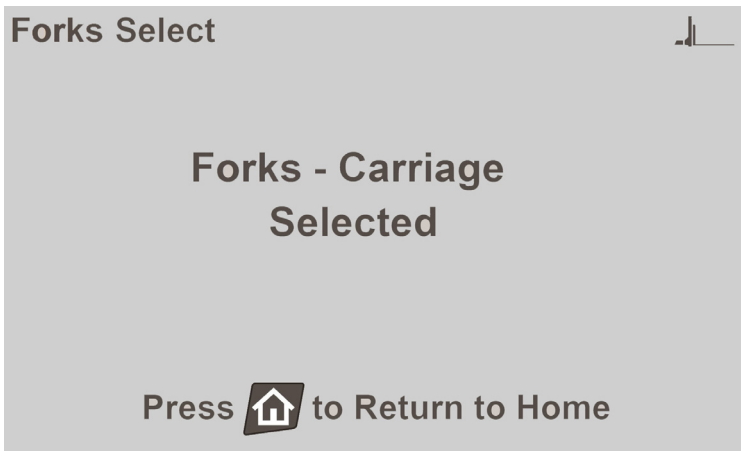

OAP0150

4. A message screen will display to confirm the selection. Press Home Screen button to go to home screen, the capacity chart for the selected attachment will display.

**B. Outriggers Position Selection (if equipped)**

If machine is equipped with outriggers, the display will show the capacity chart based on the selected outriggers position. See page 5-5 for use of the capacity chart.

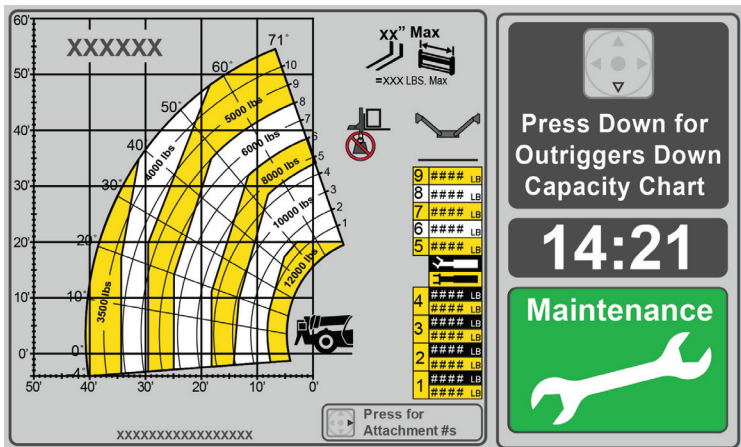

OAP0340

**Note:** The default capacity chart is outriggers up.

1. Press down arrow of the Navigation button to display outriggers down capacity chart.

## Section 3- Controls and Indicators

2. Press up arrow of the Navigation button to display outriggers up capacity chart.

### Reversing Camera (if equipped)

## WARNING

**CRUSH HAZARD.** Running into persons or objects can cause death, serious injury, or damage to property and equipment. Always check mirrors and area behind vehicle before and when backing up. Reverse systems are for supplementary use only.

The reversing camera provides an additional view of the area directly behind the telehandler. The view displays on the multifunction display home screen when the telehandler is running, transmission is in reverse and when backup camera is configured to be present under machine Setup. The display automatically returns to the standard home screen when transmission is shifted out of reverse.



OAP0160

The screen provides a graphic overlay indicating approximate distances of objects at rear of telehandler.

- **Red Line:** Approximately 5 ft (1,52 m).
- **Yellow Line:** Approximately 15 ft (4,57 m).

## NOTICE

**EQUIPMENT MALFUNCTION.** Always keep camera lens clean. Camera may not operate normally at extremely high or low temperatures.



### Maintenance Schedule Screen

Maintenance schedules identify maintenance tasks required when operating hours reach an identified interval.

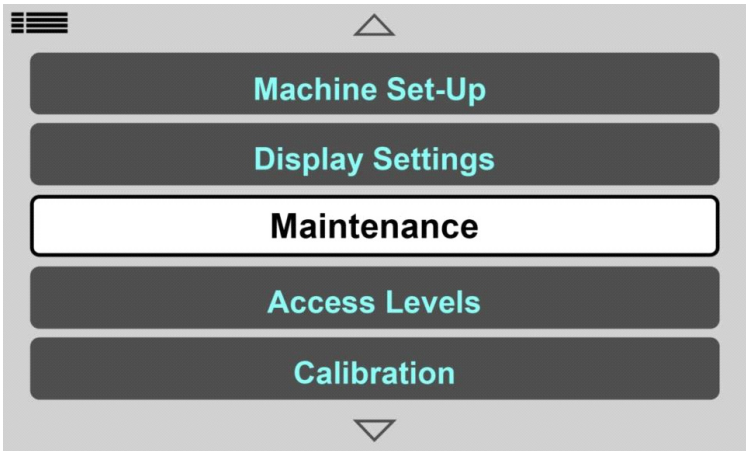

OAP0050

1. Press Main Menu button and select Maintenance.

**Note:** Scroll up or down to view all items.

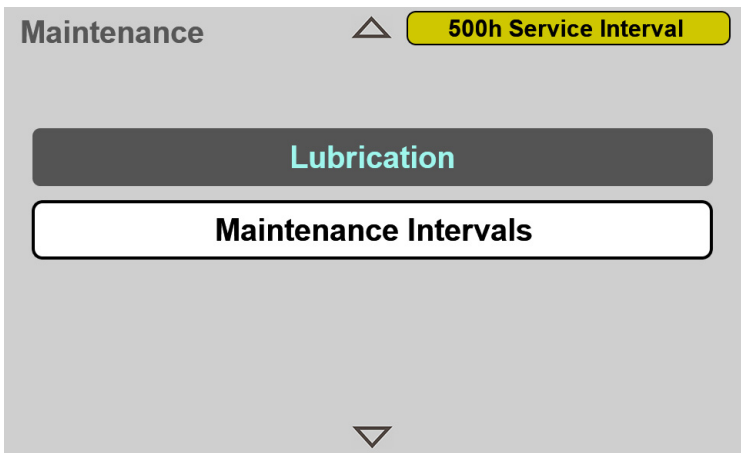

OAP0170

2. Select Maintenance Intervals.

## Section 3- Controls and Indicators

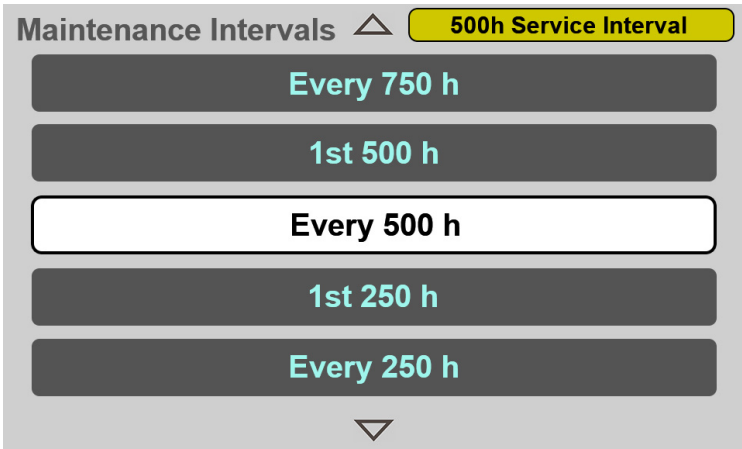

OAP0180

3. Select the required maintenance interval to view the maintenance schedule. See Section 7- Lubrication and Maintenance for additional information.

**Note:** The screen will display the current maintenance interval in the upper right corner when scheduled operating hours are reached.

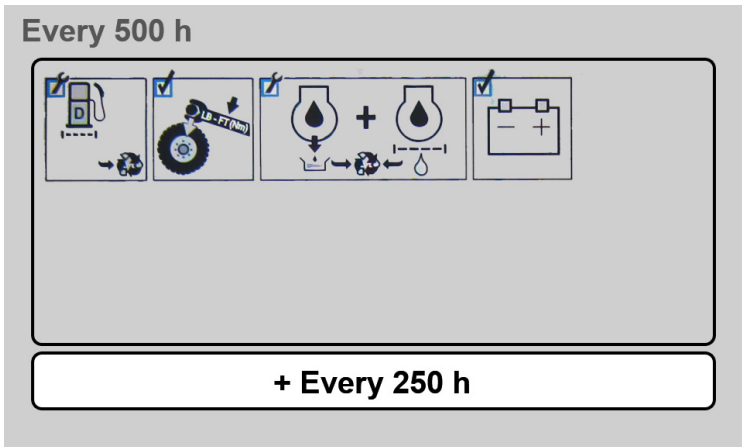

OAP0190

4. Press the center of the Navigation button to view subsequent maintenance schedules until maintenance intervals screen displays.

**Lubrication Schedule Screen**

Lubrication schedules identify lubrication tasks required when operating hours reach an identified interval.

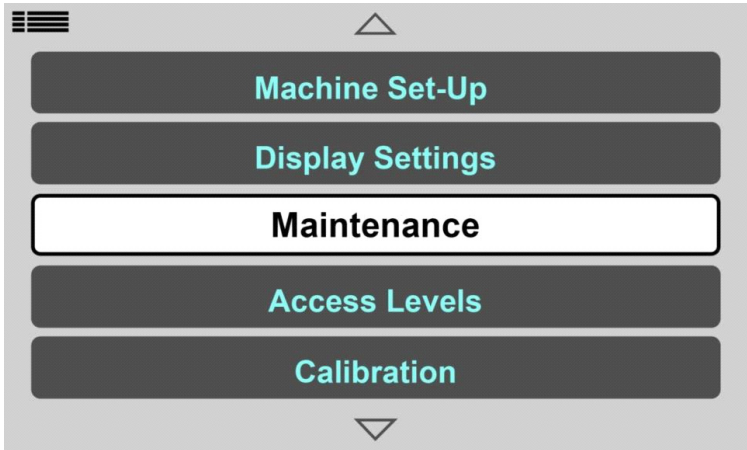

OAP0050

1. Press Main Menu button and select Maintenance.

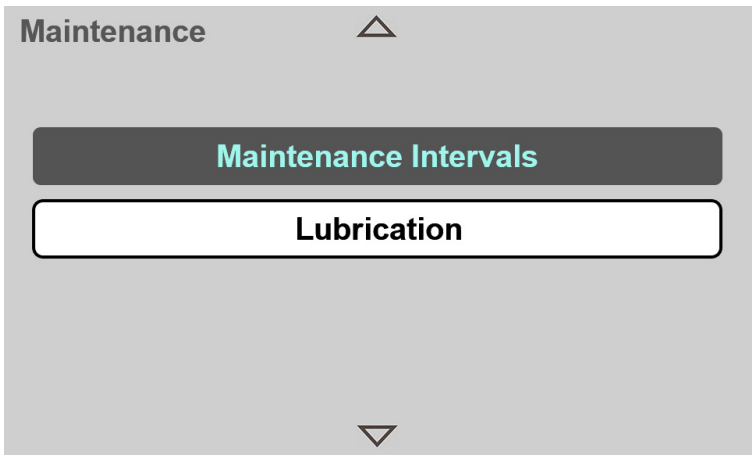

OAP0200

2. Select Lubrication to view the lubrication schedule.

## Section 3- Controls and Indicators

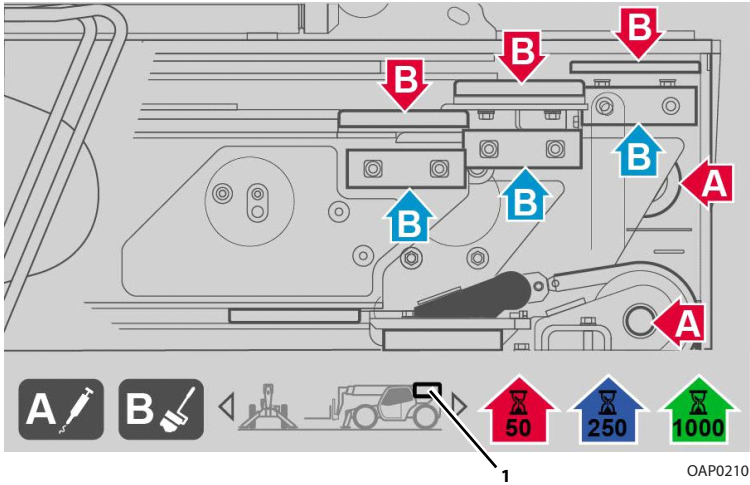

3. Use left/right arrow of the Navigation button to view lubrication points in different locations. See Section 7- Lubrication and Maintenance for additional information.

**Note:** Rectangle (1) indicates the area of the machine displayed on the screen above.

Real-Time Clock (RTC) Setup

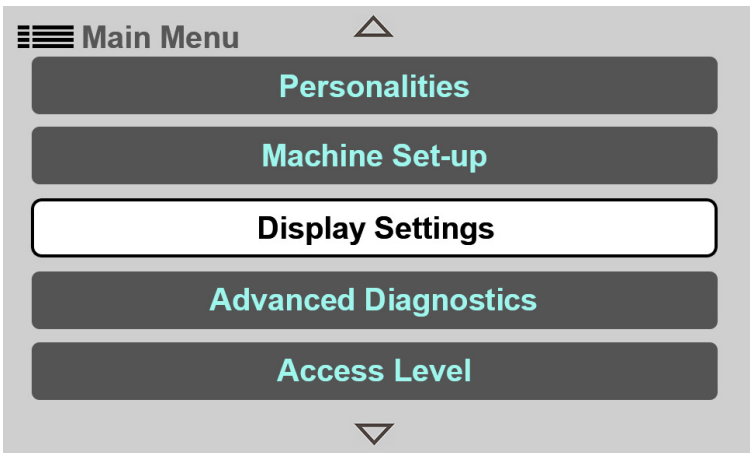

OAP0220

1. Press Main Menu button and select Display Settings.

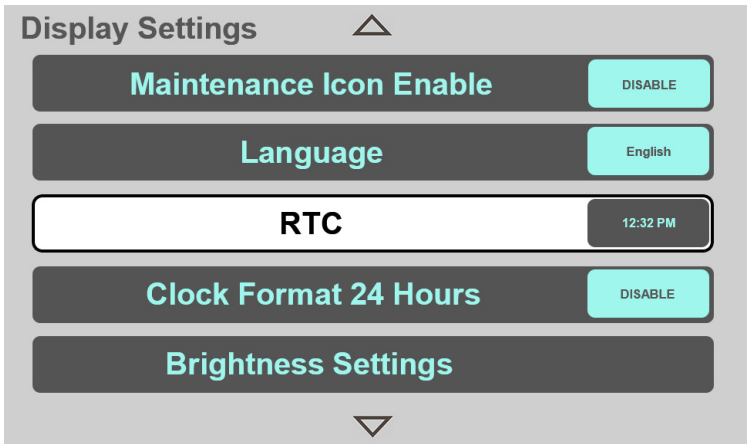

OAP0230

2. Select RTC to set the date and time.

## Section 3- Controls and Indicators

---

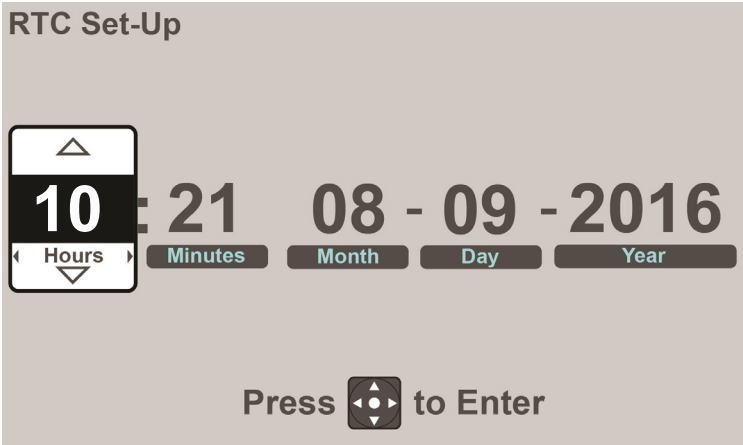

OAP0240

3. Press the up/down arrow of the Navigation button to select the first digit.
4. Press the right arrow of the Navigation button to move to the next digit.
5. Continue until the set-up is complete. Press the center of the Navigation button to confirm.

### Park Brake Test

Park brake test allows the operator to check the function of park brake.

**Note:** Each step of the calibration procedure must be completed within 60 seconds. If not, then the calibration fails and need to initiate the calibration procedure again.



## WARNING

**CRUSH HAZARD.** Running into persons or objects can cause death, serious injury, or damage to property and equipment. Always check mirrors and area around machine before performing any test. Apply service brake if machine moves.

1. Apply park brake and start engine to perform the test.

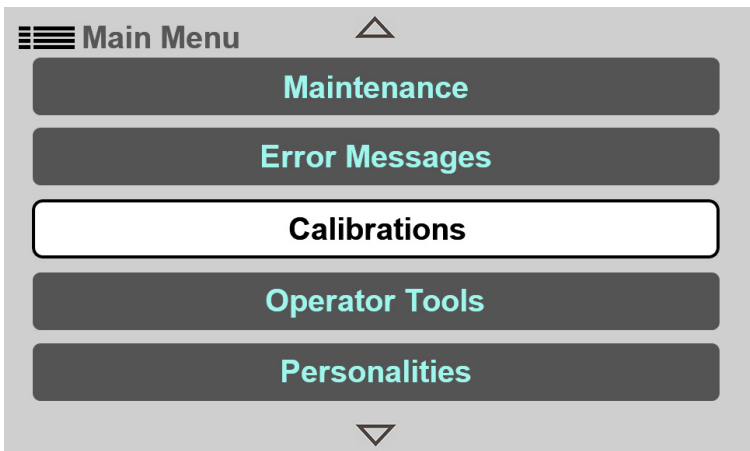

OAP0250

2. Press Main Menu button and select Calibrations.

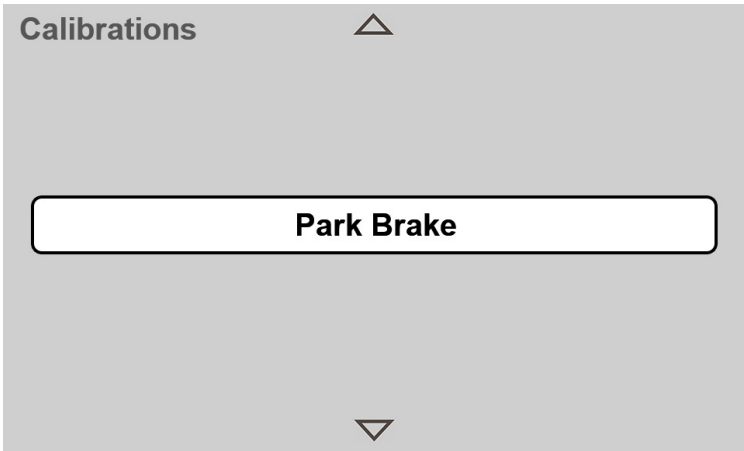

OAP0260

3. Select Park Brake.

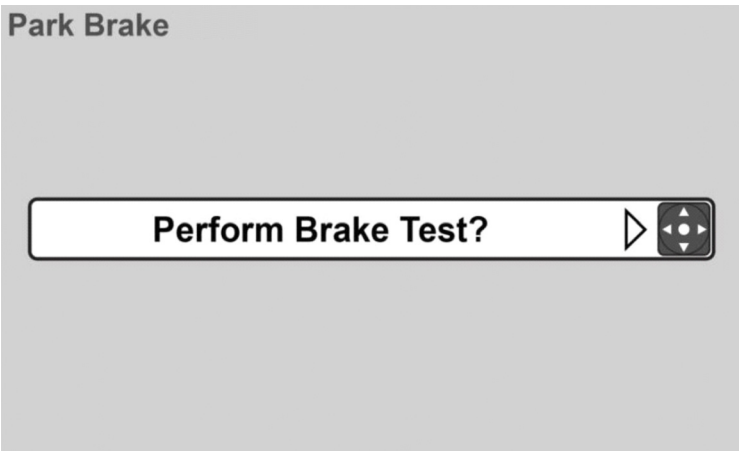

OAP0270

4. Press center of the Navigation button to confirm "Perform Brake Test?".



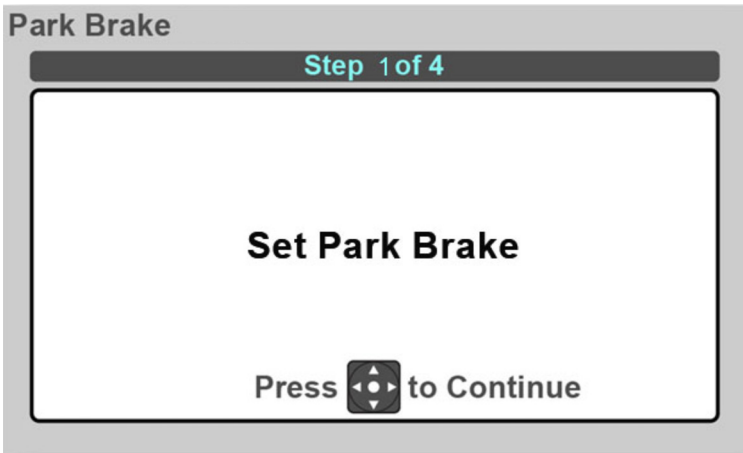

5. Ensure the park brake is engaged. Press center of the Navigation button to confirm.



6. Display shows warning message, "Warning: Drive will be engaged". Place transmission in second gear. Press center of the Navigation button to continue.

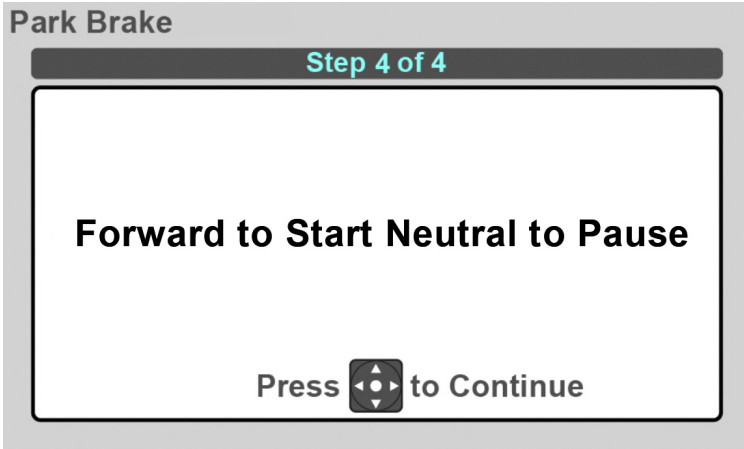

OAP0300

7. Place the transmission in Forward (F).
8. Place the transmission in Neutral (N). Press center of the Navigation button to continue.
9. "Park Brake Test Complete" will be displayed if successful. Press center of the Navigation button to confirm and return to calibrations menu.  
"Park Brake Test Failed" will be displayed if failed. Press center of the Navigation button to confirm and return to calibrations menu to repeat the test. If failed again, machine must be removed from service and repaired before continued operation.

**Troubleshooting**

**Communication Error Screen**



OAP0310

Communication error screen will be displayed if there is a communication failure. Wait for a few moments and restart the machine. If the communication error continues to display, contact the local Caterpillar dealer.

**This Page Intentionally Left Blank**

## SECTION 4 - OPERATION

### 4.1 ENGINE

**Note:** Refer to Engine Operation & Maintenance Manual for additional information.

#### Starting the Engine

This machine can be operated under normal conditions in temperatures of 0°F to 118°F (-20°C to 48°C). Consult Telehandler Product Group for operation outside this range or under abnormal conditions.

If equipped for extreme cold weather, -40°F to 0°F (-40°C to -20°C), see page 4-2 for starting procedure.

1. Make sure all controls are in "Neutral" and all electrical components (lights, heater, etc.) are turned off. Apply park brake.
2. Turn ignition switch to position 1 and wait for engine preheat indicator on instrument panel to go out.
3. Turn ignition switch to position 2 to engage starting motor. Release key immediately when engine starts. If engine fails to start within 20 seconds, release key and allow starting motor to cool for two minutes before trying again.

**Note:** If engine fails to start after three attempts, turn key to OFF position and allow starting motor to cool for 30 minutes before trying again.

4. After engine starts, observe indicators. If indicators remain on for more than five seconds, stop engine and determine cause before restarting engine.
5. Warm up engine at approximately 1/2 throttle.

**Note:** Engine will not start unless transmission is in neutral and park brake is applied.



## WARNING

**UNEXPECTED MOVEMENT HAZARD.** Always ensure that transmission is in neutral and the service brake is applied before releasing park brake. Releasing park brake in either forward or reverse could cause the machine to move abruptly.



## WARNING

**ENGINE EXPLOSION.** Do not spray ether into air intake for cold weather starting.

## **Section 4- Operation**

---

### **Extreme Cold Weather Starting (if equipped)**

---

If equipped with extreme cold weather components, machine can be operated in temperatures of -40°F to 0°F (-40° C to -20° C).

1. Machine must be equipped with heating components and extreme cold weather fluids. See Section 9- Specifications for fluid details.
2. Locate the two yellow extension cords stored behind seat in cab.
3. Connect the oil pan and hydraulic tank heaters to one extension cord and the battery and block heaters to the other extension cord. Connect each extension cord to separate A/C power supplies with a minimum rating of 15 Amps each.
4. Allow the heating components to operate a minimum of 12 hours prior to machine operation.
5. Follow start-up procedure on page 4-1 and allow engine to idle 20 minutes.
6. Operate all boom functions continuously for five minutes to circulate the warm hydraulic fluid.
7. Perform "*Shut-Down Procedure*" on page 4-5.
8. Disconnect A/C power supplies and place back in storage locations.
9. Machine is ready for operation.

## Battery Boosted Starting



OW0530

If battery-boost starting (jump-start) is necessary, proceed as follows:

- Never allow vehicles to touch.
- Ensure boosting vehicle engine is running.

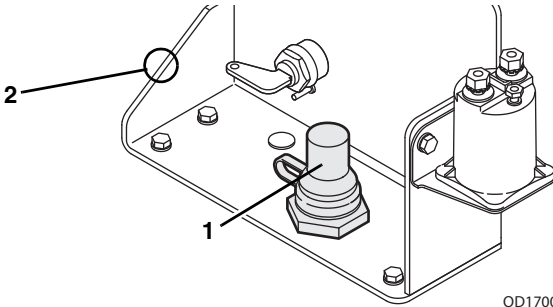

OD1700

- Remote battery post is located on right side of engine compartment for jump-starting.
- Connect positive (+) jumper cable to positive (+) post (1) of discharged battery.
- Connect opposite end of positive (+) jumper cable to positive (+) post of booster battery.
- Connect negative (-) jumper cable to negative (-) post on booster battery.
- Connect opposite end of negative (-) jumper cable to ground point on machine (2).
- Follow standard starting procedures.
- Remove cables in reverse order after machine has started.



## WARNING

**BATTERY EXPLOSION HAZARD.** Never jump start or charge a frozen battery as it could explode. Keep sparks, flames and lighted smoking materials away from battery. Lead acid batteries generate explosive gases when charging. Wear safety glasses.

## **Section 4- Operation**

---

### **Normal Engine Operation**

---

- Observe instrument panel and display frequently to be sure all systems are functioning properly.
- **Be alert for unusual noises or vibration.** When an unusual condition is noticed, park machine in safe position and perform shut-down procedure. Report condition to your supervisor or maintenance personnel.
- **Avoid prolonged idling.** If engine is not being used, turn it off.
- If prolonged idling is required (park brake applied and all controls in neutral), engine idle may increase.
- When operating a machine at high altitudes, a decrease in machine performance may occur due to a decrease in air density. When operating a machine at high temperatures, a decrease in machine performance and an increase in engine coolant temperature may occur. Contact the local Caterpillar dealer for operation under abnormal conditions.



---

## **Shut-Down Procedure**

---

When parking the telehandler, park in a safe location on flat level ground and away from other equipment and/or traffic lanes.

1. Apply park brake.
2. Shift transmission to "Neutral".
3. Lower forks or attachment to ground.
4. Operate engine at low idle for 3 to 5 minutes. **DO NOT over rev engine.**
5. Shut off engine and remove ignition key.
6. Exit telehandler properly.

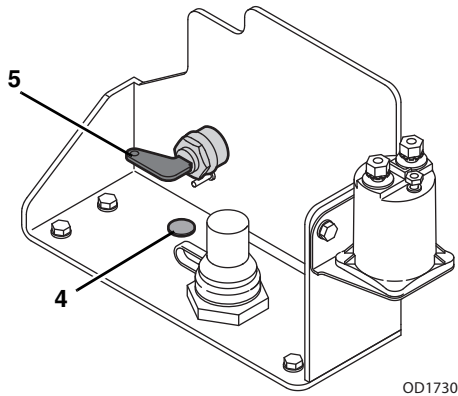

7. Purge indicator (4) will illuminate until DEF is purged from the system. Do not turn key (5) to off while indicator is illuminated.
8. Turn off electrical master switch.
9. Block wheels (if necessary).

## Section 4- Operation

---

### 4.2 OPERATING WITH A NON-SUSPENDED LOAD

#### Lift Load Safely

---

- You must know weight and load center of every load you lift. If you are not sure of weight and load center, check with your supervisor or with supplier of the material.



## WARNING

**TIP OVER HAZARD.** Exceeding lift capacity of the telehandler could damage the equipment and/or cause tip over.

- Know rated load capacities (refer to Section 5) of telehandler to determine operating range in which you can safely lift, transport and place a load.

#### Picking Up a Load

---

- Note conditions of the terrain. Adjust travel speed and reduce amount of load if conditions warrant.
- Avoid lifting double-tiered loads.
- Make sure load is clear of any adjacent obstacles.
- Adjust spacing of forks so they engage the pallet or load at maximum width. See *"Adjusting/Moving Forks"* on page 5-13.
- Approach load slowly and squarely with fork tips straight and level. **NEVER** attempt to lift a load with just one fork.
- **NEVER** operate telehandler without a proper and legible capacity chart in operator cab for telehandler/attachment combination you are using.

## **Transporting a Load**

---



- After engaging the load and resting it against the backrest, tilt the load back to position it for travel. Travel in accordance with the requirements set forth in Section 1- General Safety Practices and Section 5- Attachments.

## **Leveling Procedure**

---

1. Position machine in best location to lift or place load.
2. Apply parking brake and shift transmission to NEUTRAL.
3. Observe level indicator(s) to determine whether machine must be leveled prior to lifting load. If equipped, level machine with frame level switch (see page 3-3) or outrigger controls (see page 3-3 or 3-17).
4. Move boom/attachment to 4 ft (1,2 m) off ground.  
(AUS - Move boom so forks are no more than 11.8 in (300 mm) above ground surface.)

### **Important things to remember:**

- Never raise boom/attachment more than 4 ft (1,2 m) above ground unless telehandler is level.  
(AUS - Never raise the forks more than 300 mm (11.8 in) above ground surface unless telehandler is level.)
- Combination of frame leveling and load could cause telehandler to tip over.

## **Section 4- Operation**

---

### **Placing a Load**

---

Before placing any load be sure that:

- Landing point can safely support weight of the load.
- Landing point is level; front to back and side to side.
- Use capacity chart to determine safe boom extension range. See *"Use of the Capacity Chart"* on page 5-5.
- Align forks at level the load is to be placed, then position boom slowly until load is just above area where it is to be placed.
- Lower the boom until the load rests in position and the forks are free to retract.

### **Disengaging a Load**

---

Once the load has been placed safely at the landing point, proceed as follows:

1. With forks free from weight of load, boom can be retracted.
2. Lower carriage.
3. Telehandler can now be driven from landing location to continue work.

---

## 4.3 OPERATING WITH A SUSPENDED LOAD

---

### Lift Load Safely

---

- You must know weight and load center of every load you lift. If you are not sure of weight and load center, check with your supervisor or with supplier of the material.



## WARNING

**TIP OVER HAZARD.** Exceeding lift capacity of the telehandler could damage the equipment and/or cause tip over.

- Know rated load capacities (refer to Section 5) of telehandler to determine operating range in which you can safely lift, transport and place a load.

### Picking Up a Suspended Load

---

- Note conditions of terrain. Adjust travel speed and reduce amount of load if conditions warrant.
- Avoid lifting double-tiered loads.
- Make sure load is clear of any adjacent obstacles.
- **NEVER** operate telehandler without a proper and legible capacity chart in operator cab for telehandler/attachment combination you are using.
- Only use approved lifting devices rated for lifting of load.
- Identify proper lifting points of load, taking into consideration center of gravity and load stability.
- Ensure to always properly tether loads to restrict movement.
- Refer to “*Use of the Capacity Chart*” on page 5-5 for proper lifting guidelines in addition to appropriate capacity chart in operator cab.

## Section 4- Operation

---

### Transporting a Suspended Load

---



OZ3160

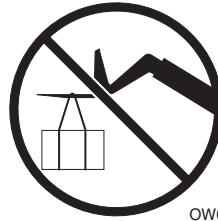

OW0130

- Travel in accordance with the requirements set forth in Section 1- General Safety Practices and Section 5- Attachments.
- For additional requirements, refer to appropriate capacity chart in operator cab.

#### **Important things to remember:**

- Ensure boom is fully retracted.
- Never raise load more than 11.8 in (300 mm) above ground surface or boom more than 45°.
- Combination of frame leveling and load could cause telehandler to tip over.
- Guide persons and operator must remain in constant communication (verbal or hand) and be in visual contact with operator at all times.
- Never place guide persons between suspended load and telehandler.
- Only transport load at walking speed, 0.9 mph (0.4 m/s), or less.

#### **Leveling Procedure**

---

1. Position machine in best location to lift or place load.
2. Apply parking brake and shift transmission to NEUTRAL.
3. Observe level indicator(s) to determine whether machine must be leveled prior to lifting load. If equipped, level machine with frame level switch (see page 3-3) or outrigger controls (see 3-17).
4. Move boom so load is no more than 11.8 in (300 mm) above ground surface and boom/or boom is raised no more than 45°.

## **Placing a Suspended Load**

---

Before placing any load be sure that:

- Landing point can safely support weight of load.
- Landing point is level; front to back and side to side.
- Use capacity chart to determine safe boom extension range. See *"Use of the Capacity Chart"* on page 5-5.
- Align load at level the load is to be placed, then position boom slowly until load is just above area where it is to be placed.
- Ensure that guide persons and operator remain in constant communication (verbal or hand) when placing load.

## **Disengaging a Suspended Load**

---

- Never place guide persons between suspended load and telehandler.
- Once at destination of load, ensure to bring telehandler to a complete stop and apply park brake prior to disengagement of lifting devices and tethers.

## Section 4- Operation

### 4.4 LOADING AND SECURING FOR TRANSPORT

#### Tie Down

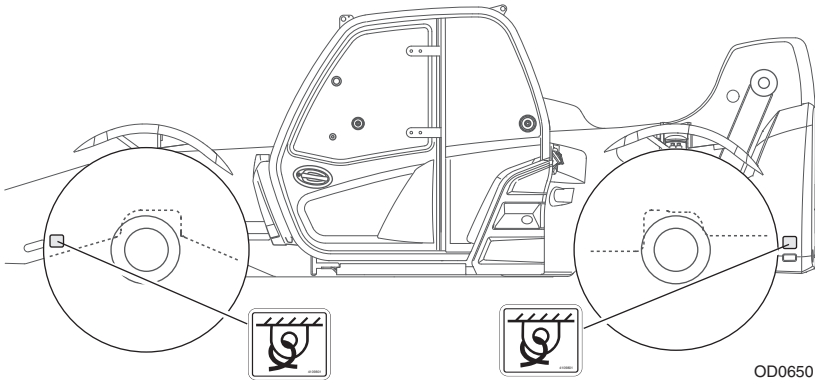

1. Level telehandler prior to loading.
2. Using a spotter, load telehandler with boom as low as possible.
3. Once loaded, apply parking brake and lower boom until boom or attachment is resting on deck. Move all controls to "Neutral," stop engine and remove ignition key.
4. Secure machine to deck by passing chains through designated tie down points as shown in figure.
5. Do not tiedown front of boom.

**Note:** User assumes all responsibility for choosing proper method of transportation and tie-down devices, making sure equipment used is capable of supporting weight of vehicle being transported and that all manufacturer's instructions and warnings, regulations and safety rules of their employer, Department of Transportation and/or any other local, state or federal/provincial laws are followed.



## WARNING

**TELEHANDLER SLIDE HAZARD.** Before loading telehandler for transport, make sure deck, ramps and telehandler wheels are free of mud, snow and ice. Failure to do so could cause telehandler to slide.



## Lifting

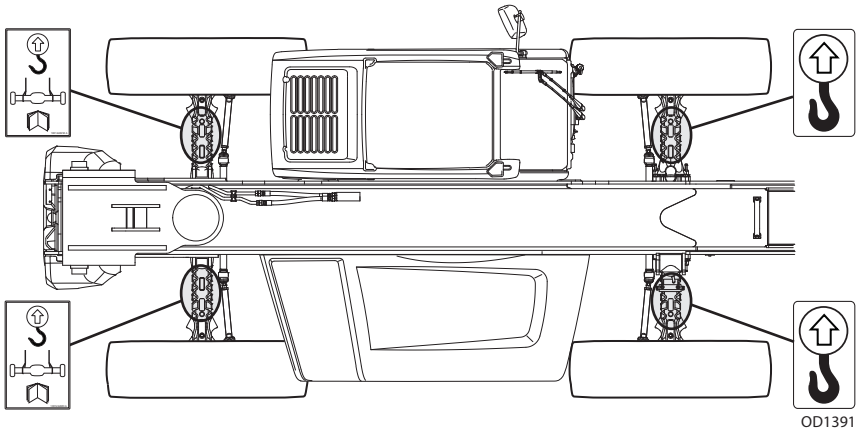

OD1391

The weight of the machine is listed on the serial number plate located at the front of the frame. Actual machine weight and center of gravity will vary depending on attachment, fluid levels and machine options. Actual weight and center of gravity should be verified prior to lifting.

The following precautions must be taken when lifting the machine with a mobile crane:

- Make adjustments to the lifting device and equipment to ensure that the machine will be level when elevated. The machine must remain level at all times while being lifted.
- Machine must never be lifted by any point on the boom.
- Take care not to let cables, chains, slings, etc. contact any part of the vehicle during lift.
- The appropriate lifting locations are the axle beams, inboard of the kingpins. Take care as not to damage the axles and components.
- Ensure that the boom is retracted and lowered.
- Ensure that the lifting device and equipment is adequately rated and suitable for the intended purpose.
- Remove all loose items from machine prior to lifting of the machine.
- Lift at a slow, even pace.
- Obtain any additional training regarding the proper lifting procedures that may be required. Please consult the local, state, and employer regulations.

**This Page Intentionally Left Blank**

---

## **SECTION 5 - ATTACHMENTS**

---

### **5.1 APPROVED ATTACHMENTS**

To determine if an attachment is approved for use on specific telehandler you are using, perform following prior to installation.

- The machine is authorized for use with original equipment manufactured (OEM) supplied attachments or where explicit written authorization has been provided by the manufacturer.
- The model on the capacity chart must match the model telehandler being used.
- Hydraulically powered attachments must only be used on machines equipped with auxiliary hydraulics.
- Hydraulically powered attachments that require auxiliary electrics must only be used on machines equipped with auxiliary hydraulics and electrics.

If any of the above conditions are not met, do not use attachment. Telehandler may not be equipped with proper capacity chart or attachment may not be approved for the model telehandler being used. Contact the local Caterpillar dealer for further information.

---

### **5.2 UNAPPROVED ATTACHMENTS**

Do not use unapproved attachments for the following reasons:

- Range and capacity limitations for “will fit,” homemade, altered, or other non-approved attachments cannot be established.
- An overextended or overloaded telehandler can tip over with little or no warning and cause serious injury or death to the operator and/or those working nearby.
- The ability of a non-approved attachment to perform its intended function safely cannot be assured.



## **WARNING**

Use only approved attachments. Attachments which have not been approved for use with your telehandler could cause machine damage or an accident.

## Section 5- Attachments

### 5.3 JLG SUPPLIED ATTACHMENTS

Attachment	Part Number	Applicable Model			
		TL642D	TL943D	TL1055D	TL1255D
Carriage, 50 in (1270 mm)	474-2531	X	X	X	X
	301-9757	X	X	X	X
Carriage, 60 in (1524 mm)	474-0139	X	X	X	X
	500-4475	X	X	X	X
Carriage, 72 in (1829 mm)	474-2532	X	X	X	X
	301-9758	X	X	X	X
Side Shift Carriage, 50 in (1270 mm)	474-0141	X	X	X	X
Side Tilt Carriage, 50 in (1270 mm)	309-4315	X	X	X	X
	549-8955	X	X	X	X
Side Tilt Carriage, 72 in (1829 mm)	309-4316	X	X	X	X
	549-8956	X	X	X	X
Side Tilt Carriage, 48 in (1220 mm)	341-3590				X
Side Tilt Carriage, 72 in (1829 mm)	474-0140				X
100° Swing Carriage, 72 in (1829 mm)	318-9222	X	X	X	X
180° Swing Carriage, 72 in (1829 mm)	341-3591			X	X
	560-2577			X	X
Dual Fork Positioning Carriage, 50 in (1270 mm)	397-6838	X	X	X	X
	555-1350	X	X	X	X
Dual Fork Positioning Carriage, 72 in (1829 mm)	555-1351	X	X	X	X
Fork, Pallet 2.4x4.0x48 in (60x100x1220 mm)	301-9755	X	X	X	
Fork, Pallet 2.4x4.9x48 in (60x125x1220 mm)	301-9753	X	X	X	X
Fork, Pallet 2.4x4.9x60 in (60x125x1524 mm)	550-9930	X	X	X	X
Fork, Pallet 2.4x4.9x72 in (60x125x1829 mm)	567-1247	X	X	X	X
Fork, Lumber 1.6x5.9x60 in (40x150x1540 mm)	323-5737	X	X	X	X
Fork, Lumber 1.75x7x60 in (45x180x1524 mm)	301-9756	X	X	X	
Fork, Lumber 2.36x6x60 in (60x150x1524 mm)	301-9754	X	X	X	X
Fork, Dual Taper 2.0x6.0x72 in (50x150x1830 mm)	311-2854	X	X	X	X
Fork, Block 2.0x2.0x48 in (50x50x1220 mm)	301-9752	X	X	X	X
Fork Extension, 90 in (2286 mm)	397-6114	X	X	X	X

Attachment	Part Number	Applicable Model			
		TL642D	TL943D	TL1055D	TL1255D
Pipe Grapple	486-0526			X	X
Bucket, 95 in–1.3 yd <sup>3</sup> (2418 mm–1,0 m <sup>3</sup> )	163-4261	X	X	X	X
	456-0498	X	X	X	X
Bucket, 95 in–2.0 yd <sup>3</sup> (2418 mm–1,5 m <sup>3</sup> )	186-5838	X	X	X	X
	456-0507	X	X	X	X
Bucket, 102 in–2.0 yd <sup>3</sup> (2600 mm–1,5 m <sup>3</sup> )	474-0148	X	X	X	X
Multipurpose Bucket, 95 in–1.3 yd <sup>3</sup> (2418 mm–1,03 m <sup>3</sup> )	163-4265	X	X	X	X
	486-0141	X	X	X	X
Grapple Bucket, 96 in–1.7 yd <sup>3</sup> (2450 mm–1,3 m <sup>3</sup> )	474-0142	X	X	X	X
Hook, Fork Mounted	321-0556	X	X	X	X
Hook, Coupler Mounted	456-0465	X	X	X	X
Trash Hopper, Fork Mounted	486-0529	X	X	X	X
Sweeper	486-0528	X	X	X	X
Truss Boom, 12 ft (3,7 m)	474-0144	X	X	X	X
Truss Boom, 13.1 ft (4,0 m)	169-3945	X	X	X	X
	456-0473	X	X	X	X
Truss Boom, 15 ft (4,6 m)	474-0145	X	X	X	X
Truss Boom w/ Winch, 3 ft (0,9 m)	491-9893	X	X	X	X
Truss Boom w/ Winch, 12 ft (3,7 m)	474-0147	X	X	X	X
Truss Boom, Adjustable, Fork Mounted	549-5456	X	X	X	X
Material Handling Arm, 6.7–13.2 ft (2-4 m)	229-9714	X	X	X	X
Platform, Fork Mounted (ASME)	343-9736	X	X	X	X
Platform, Fork Mounted (ASME - French)	343-9738	X	X	X	X
Platform, Fork Mounted (ISO)	343-9737	X	X	X	X

\* Part number not available at publication.

## Section 5- Attachments

### 5.4 TELEHANDLER/ATTACHMENT/FORK CAPACITY

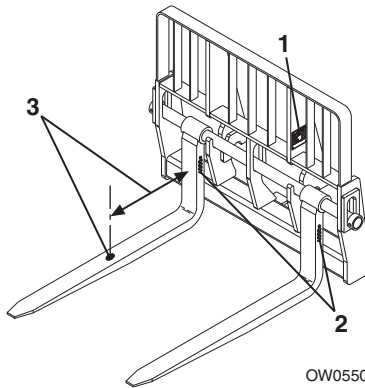

Prior to installing attachment, verify it is approved and telehandler is equipped with proper capacity chart. See *“Approved Attachments”* on page 5-1.

To determine maximum capacity of telehandler and attachment, use the **smallest** of the following capacities:

- Capacity stamped on attachment identification plate (1).
- Fork capacities and load centers are stamped on the side of each fork (2) (if equipped). This rating specifies maximum load capacity that the individual fork can safely carry at maximum load center (3). Total attachment capacity is multiplied by number of forks on attachment (if equipped), up to maximum capacity of attachment.
- Maximum capacity as indicated on the proper capacity chart. See *“Approved Attachments”* on page 5-1.
- When load rating of telehandler differs from capacity of the forks or attachment, the lower value becomes the overall load capacity.

Use the proper capacity chart to determine maximum capacity at various machine configurations. Lifting and placing a load may require use of more than one capacity chart based on machine configuration.

Other than block forks, all forks should be used in matched pairs, block forks used in matched sets.



## WARNING

Never use an attachment without the appropriate manufacturer approved capacity chart installed on the telehandler.

## **5.5 USE OF THE CAPACITY CHART**

To properly use capacity chart (see page 5-6), operator must first determine and/or have the following:

1. An approved attachment. See "Approved Attachments" on page 5-1.
2. Proper Capacity Chart(s).
3. Weight of load being lifted.
4. Load placement information:
  - a. HEIGHT where load is to be placed.
  - b. DISTANCE from front tires of telehandler where load is to be placed.
5. On capacity chart, find the line for height and follow it over to distance.
6. Number in load zone where the two cross is the maximum capacity for this lift. If the two cross at a division between zones, the smaller number must be used.

The number in load zone must be equal to or greater than weight of load to be lifted. Determine limits of load zone on capacity chart and keep within these limits.

### **Capacity Indicator Locations**

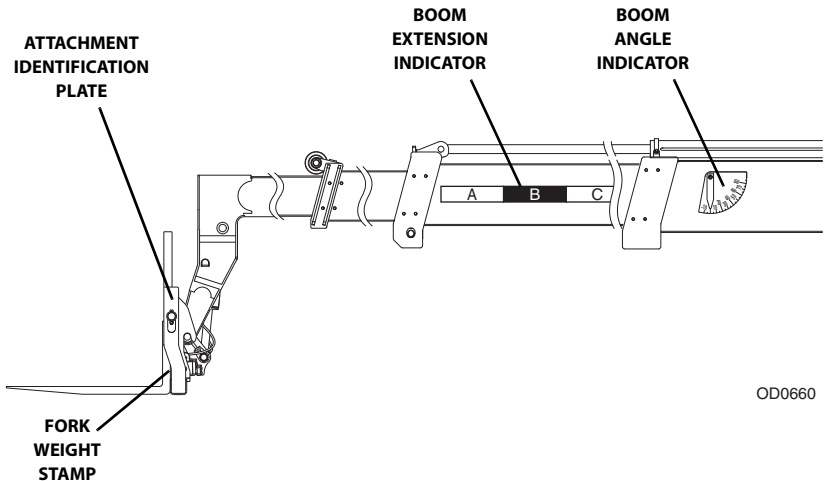

# Section 5- Attachments

## Sample Capacity Chart

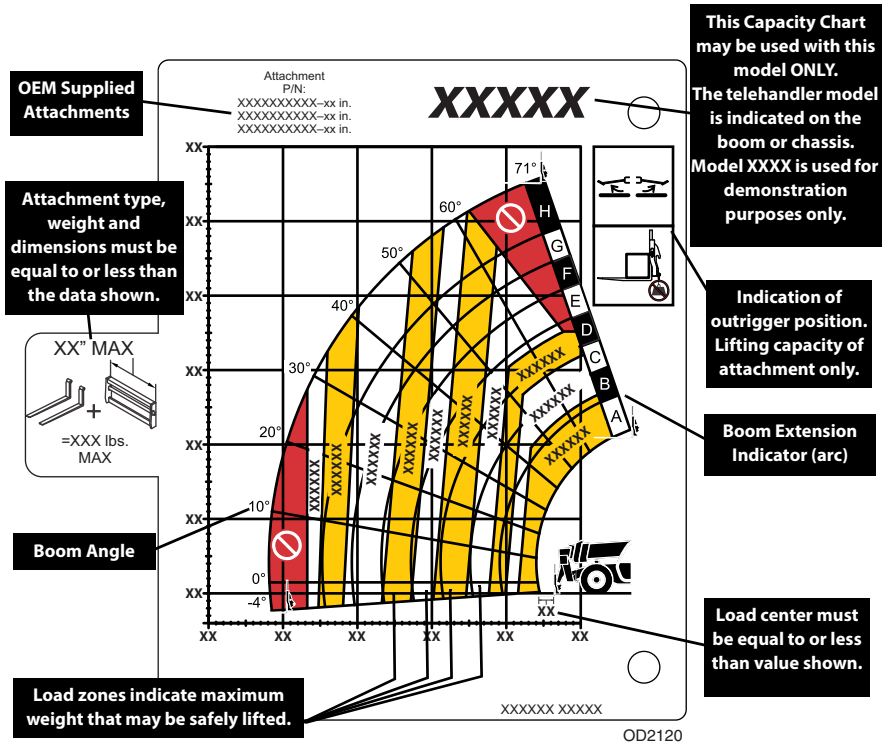



**Note:** This is sample capacity chart **only! DO NOT** use this chart, use the one located in your operator cab.

# ⚠ WARNING

**TIP OVER HAZARD.** All loads shown on rated capacity chart are based on machine being on firm ground with frame level (see page 4-7 or 4-10); the forks being positioned evenly on carriage; the load being centered on forks; proper size tires being properly inflated; and the telehandler being in good operating condition.

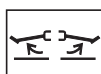
To identify the proper capacity chart on telehandlers equipped with outriggers, refer to the following icons which may be located on the capacity chart.

- Use when lifting a load with outriggers up.  OD1080
- Use when lifting a load with outriggers down.  OD1070



**Example**

A contractor owns a model xxxx telehandler with a fork carriage. The contractor knows this attachment may be used with his model since:

- The part number on the attachment identification plate matches the attachment part number on a capacity chart located in the operator cab.
- Attachment style, weight, dimensions and load center match the attachment data on the capacity chart.
- Capacity chart is clearly marked for model xxxx and corresponds with machine configuration being used.

Below are examples with various conditions the contractor may encounter and whether or not the load may be lifted.

	Load Weight	Distance	Height	OK to Lift
1	5750lb (2608 kg)	25 ft (7,62 m)	10 ft (3 m)	Yes
2	4900lb (2223 kg)	30 ft (9,2m)	30 ft (9,2 m)	NO
3	8100lb (3674 kg)	5 ft (1,5 m)	30 ft (9,2 m)	Yes
4	5250lb (2381kg)	15ft (4,6 m)	45 ft (13,7 m)	NO

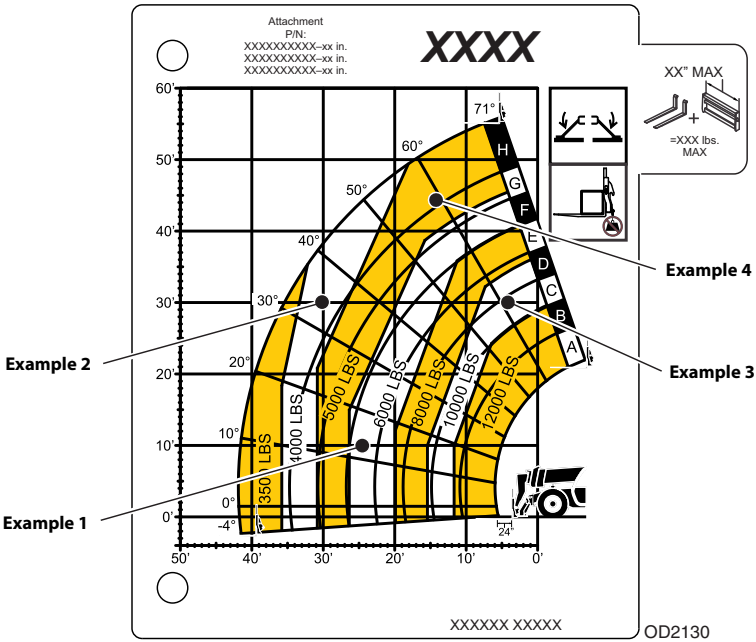

**Note:** This is a sample capacity chart **only!** **DO NOT** use this chart, use the one located in your operator cab.

**This Page Intentionally Left Blank**

## 5.6 ATTACHMENT INSTALLATION

### Coupler

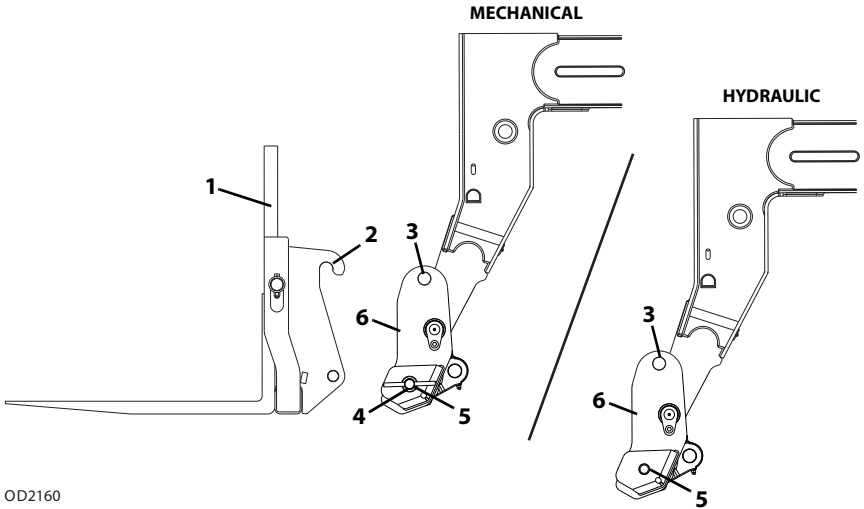

OD2160

1. **Attachment**
2. **Attachment Pin Recess**
3. **Attachment Pin**
4. **Retainer Pin** (right side of mechanical coupler)
5. **Lock Pin**
6. **Coupler** (attachment tilt control in cab, see page 3-18)



## WARNING

**CRUSH HAZARD.** Always be certain that carriage or attachment is properly positioned on boom and is secured by lock pin and retainer pin. Failure to ensure proper installation could permit carriage/attachment/load to disengage.

## Section 5- Attachments

### Mechanical Coupler

This installation procedure is designed for one-person operation. Prior to exiting cab, perform "Shut-Down Procedure" on page 4-5.

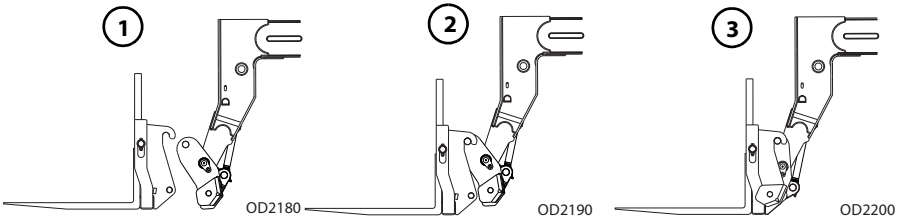

1. Tilt coupler forward to provide clearance. Check to be sure lock pin is removed.
2. Align attachment pin with recess in attachment. Raise boom slightly to engage attachment pin in recess.
3. Tilt coupler back to engage attachment.

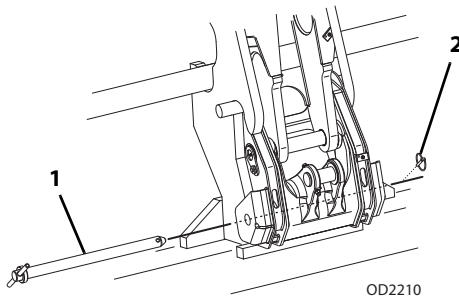

4. Insert lock pin (1) completely through coupler. Insert pin (2) and ensure lock pin is secure.
5. If attachment is equipped, connect auxiliary hydraulic hoses. See "Auxiliary Hydraulic Decompression" on page 5-12.
6. If equipped, connect auxiliary electric harness.

### Hydraulic Coupler

This installation procedure is designed for one-person operation.

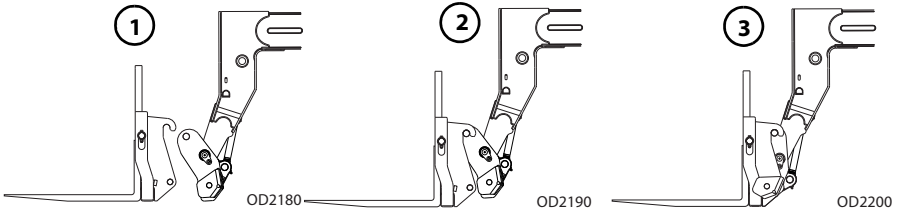

1. Tilt coupler forward to provide clearance.
2. Align attachment pin with recess in attachment. Raise boom slightly to engage attachment pin in recess.
3. Check to be sure lock pin is disengaged. Tilt coupler back to engage attachment.

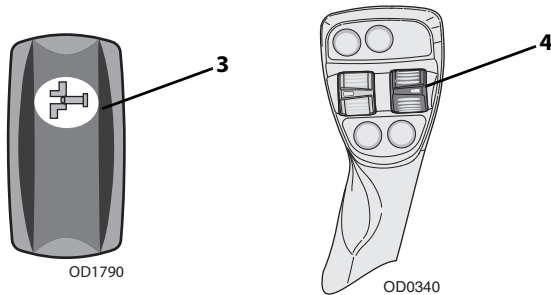

4. Press and hold the coupler switch (3) on left control panel. At the same time, press roller switch (4) up to engage lock pin. Press roller switch (4) down to disengage lock pin.

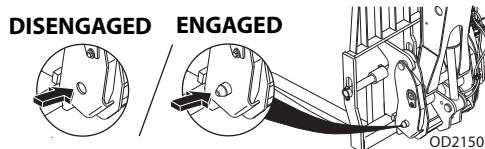

5. Raise boom to eye level and visually check that lock pins protrude through holes on both sides of coupler. If lock pins do not protrude through holes, place attachment on ground and return to step 2.
6. If attachment is equipped, connect auxiliary hydraulic hoses. See "Auxiliary Hydraulic Decompression" on page 5-12.
7. If equipped, connect auxiliary electric harness.

## Section 5- Attachments

### Auxiliary Hydraulic Decompression

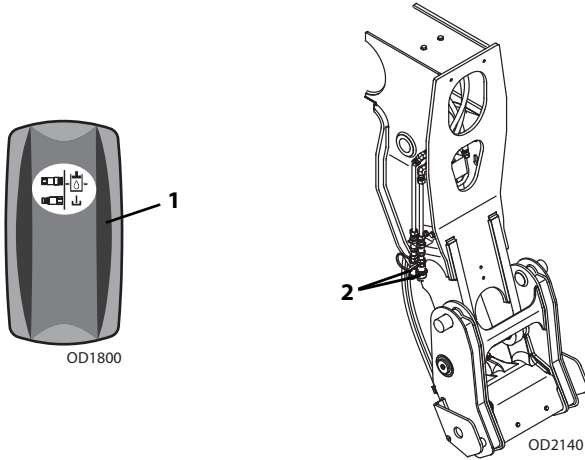

1. With engine running and attachment installed and lowered to the ground, press and hold auxiliary decompression switch (1) on right control panel for three seconds to relieve pressure at both auxiliary hydraulic fittings (2).
2. Perform "Shut-Down Procedure" on page 4-5.
3. Attachment hoses may be connected or disconnected at both auxiliary hydraulic fittings.

### 5.7 ADJUSTING/MOVING FORKS

Carriages may have different locations where forks can be positioned. Two different methods can be used for repositioning, depending upon carriage structure.

**Note:** *Apply a light coating of appropriate lubricant to ease sliding of forks or fork bar.*

**To slide forks:**

1. Ensure attachment is properly installed. See "Attachment Installation" on page 5-9.
2. If equipped, loosen fork locking bolt.
3. Elevate attachment to approximately 5 ft (1,5 m) and tilt carriage forward until fork heel is free from attachment.
4. Stand at side of carriage. To slide fork toward center of carriage, push fork near fork eye. To slide fork toward edge of carriage, pull fork near fork eye. To avoid pinching, do not place fingers or thumb between fork and carriage structure.
5. If equipped, tighten fork locking bolt.

**If removing fork bar is necessary:**

1. Rest forks on ground.
2. If equipped, loosen fork locking bolt.
3. Remove fork bar.
4. Reposition forks.
5. Reinstall the fork bar and fork bar retaining mechanism(s).
6. If equipped, tighten fork locking bolt.

**5.8 ATTACHMENT OPERATION**

- Capacities and range limits for telehandler change depending on attachment in use.
- Separate attachment instructions must be kept in manual holder in cab with this Operation & Safety Manual. An additional copy must be kept with attachment if it is equipped with a manual holder.

***NOTICE***

**EQUIPMENT DAMAGE.** Some attachments may contact front tires or machine structure when the boom is retracted and the attachment is rotated. Improper use of attachment may result in attachment or machine structural damage.

***NOTICE***

**EQUIPMENT DAMAGE.** Avoid contact with any structure or object when lifting a load. Maintain clearance around boom structure and load. Failure to maintain clearance may result in attachment or machine structural damage.



## Carriage with Forks

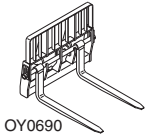

Use Carriage Attachment Capacity Chart

To determine maximum capacity, refer to "Telehandler/Attachment/Fork Capacity" on page 5-4.

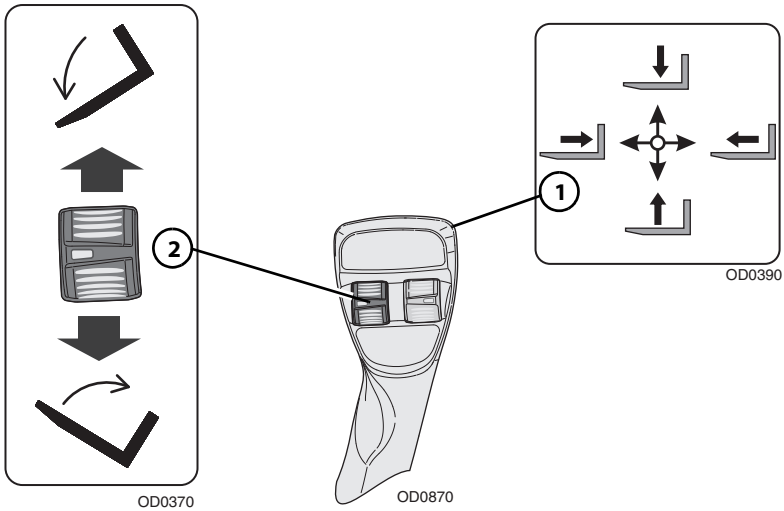

Joystick (1) controls movement of the boom.

Roller switch (2) controls carriage tilt.

- Press roller switch down to tilt up.
- Press roller switch up to tilt down.

### Installation Procedure:

Refer to "Attachment Installation" on page 5-9.

### Equipment Damage Precautions:

- Do not use forks as a lever to pry material. Excessive prying forces could damage forks or machine structure.
- Do not attempt to lift loads that are attached or connected to another object.

## Section 5- Attachments

### Side Shift Carriage

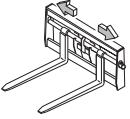

OAL1540

Use Side Shift Carriage Capacity Chart

To determine maximum capacity, refer to "Telehandler/Attachment/Fork Capacity" on page 5-4.

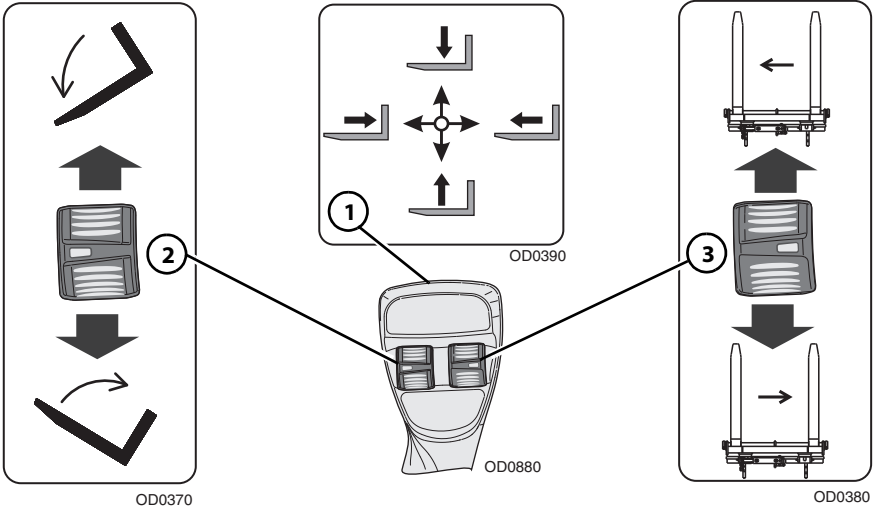

Joystick (1) controls movement of the boom.

Roller switch (2) controls carriage tilt.

- Press roller switch down to tilt up.
- Press roller switch up to tilt down.

#### To Side Shift:

Roller switch (3) controls carriage side shift.

- Press roller switch down to shift right.
- Press roller switch up to shift Left.

**Installation Procedure:**

- Refer to “Attachment Installation” on page 5-9.



**WARNING**

**CRUSH HAZARD.** Do not use side shift to push or pull objects or load. Failure to comply could cause object or load to fall.

**Equipment Damage Precautions:**

- Do not use forks as a lever to pry material. Excessive prying forces could damage forks or machine structure.
- Do not attempt to lift loads that are attached or connected to another object.

## Section 5- Attachments

### Side Tilt Carriage

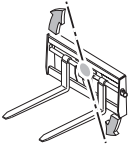

OAL1550

Use Side Tilt Carriage Attachment Capacity Chart

To determine maximum capacity, refer to "Telehandler/Attachment/  
Fork Capacity" on page 5-4.

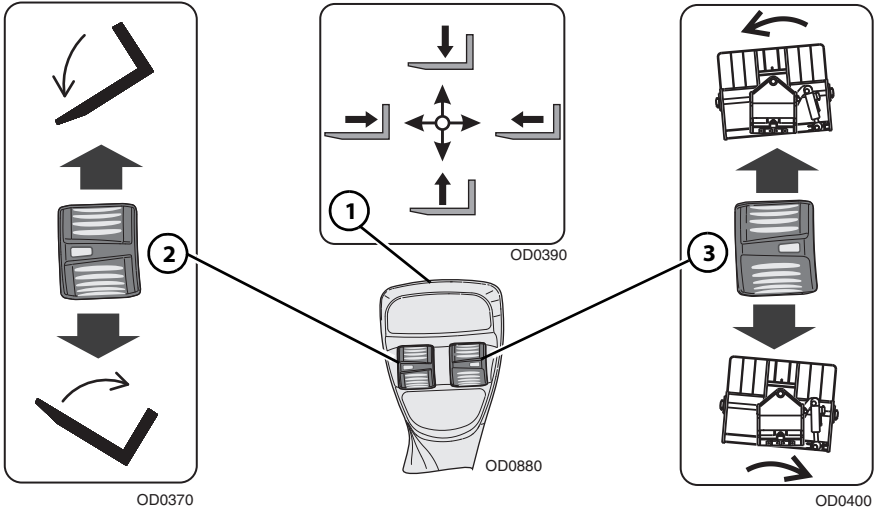

Joystick (1) controls movement of the boom.

Roller switch (2) controls carriage tilt.

- Press roller switch down to tilt up.
- Press roller switch up to tilt down.

#### To Side Tilt:

Roller switch (3) controls carriage side tilt.

- Press roller switch down to side tilt right.
- Press roller switch up to side tilt left.

### Installation Procedure:

- Refer to “Attachment Installation” on page 5-9.



## WARNING

**CRUSH HAZARD.** Do not use side tilt to push or pull objects or load. Failure to comply could cause object or load to fall.

### Operation:

- Approach load with forks centered on load and stop telehandler.
- Level telehandler before side tilting carriage to engage load.
- Side tilt carriage to left or right to align forks with load and engage load.
- Raise load slightly and level carriage side to side.
- Travel in accordance with requirements set forth in Section 1- General Safety Practices.

### Equipment Damage Precautions:

- Do not use forks as a lever to pry material. Excessive prying forces could damage forks or machine structure.
- Do not attempt to lift loads that are attached or connected to another object.

## Section 5- Attachments

### Swing Carriage

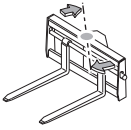

OU2150

Use Swing Carriage Attachment Capacity Chart

To determine maximum capacity, refer to "Telehandler/Attachment/Fork Capacity" on page 5-4.

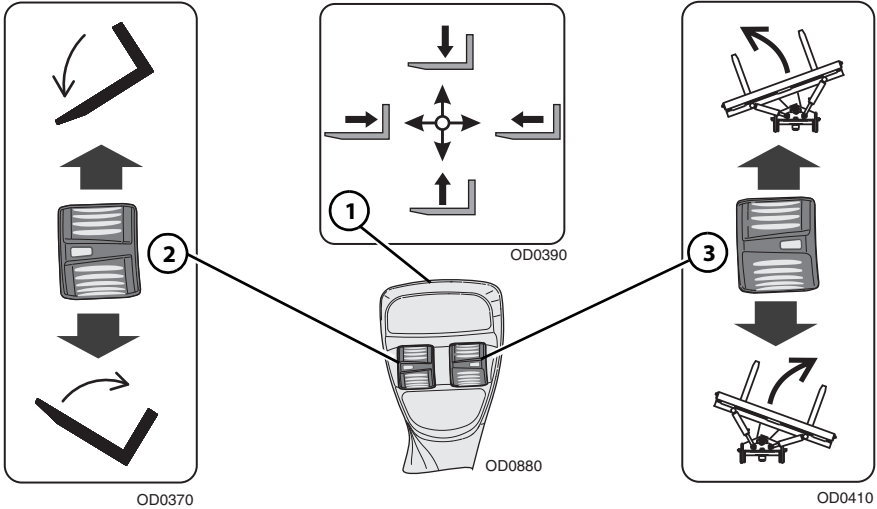

Joystick (1) controls movement of the boom.

Roller switch (2) controls carriage tilt.

- Press roller switch down to tilt up.
- Press roller switch up to tilt down.

#### To Swing:

Roller switch (3) controls carriage swing.

- Press roller switch down to swing right.
- Press roller switch up to swing left.

**Installation Procedure:**

- Refer to “Attachment Installation” on page 5-9.



**WARNING**

**CRUSH HAZARD.** Always level forks (horizontally) and telehandler frame before swinging load to side. Swinging unlevel forks could cause load to slide off forks.



**WARNING**

**CRUSH HAZARD.** Do not use swing carriage to push or pull objects or load. Failure to comply could cause object or load to fall.



**WARNING**

**CRUSH HAZARD.** Use retaining pin (if equipped) for locking swing frame to fixed frame when carrying loads greater than 5000 lb (2268 kg). Failure to comply could cause object or load to fall.

**Operation:**

- To drive with a load, keep forks pointed forward and travel in accordance with requirements set forth in Section 1- General Safety Practices.

**Equipment Damage Precautions:**

- Do not use forks as a lever to pry material. Excessive prying forces could damage forks or machine structure.
- Do not attempt to lift loads that are attached or connected to another object.

## Section 5- Attachments

### Dual Fork Positioning Carriage

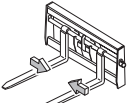

OZ3670

Use Dual Fork Positioning Carriage Capacity Chart

To determine maximum capacity, refer to "Telehandler/Attachment/Fork Capacity" on page 5-4.

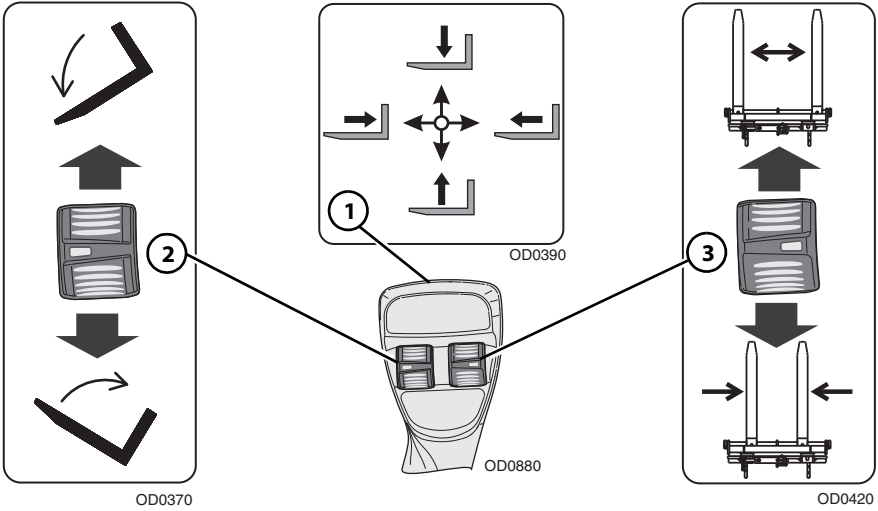

Joystick (1) controls movement of the boom.

Roller switch (2) controls carriage tilt.

- Press roller switch down to tilt up.
- Press roller switch up to tilt down.

#### To Fork Position:

Roller switch (3) controls fork position.

- Press roller switch down to shift forks in.
- Press roller switch up to shift forks out.



**Installation Procedure:**

- Refer to “Attachment Installation” on page 5-9.



**WARNING**

**CRUSH HAZARD.** Do not use fork positioning to push or pull objects or load. Failure to comply could cause object or load to fall.

**Operation:**

- Travel in accordance with requirements set forth in Section 1- General Safety Practices.

**Equipment Damage Precautions:**

- Do not use forks as a lever to pry material. Excessive prying forces could damage forks or machine structure.
- Do not attempt to lift loads that are attached or connected to another object.

## Section 5- Attachments

### Pipe Grapple



Use Pipe Grapple Attachment Capacity Chart

To determine maximum capacity, refer to "Telehandler/Attachment/Fork Capacity" on page 5-4.

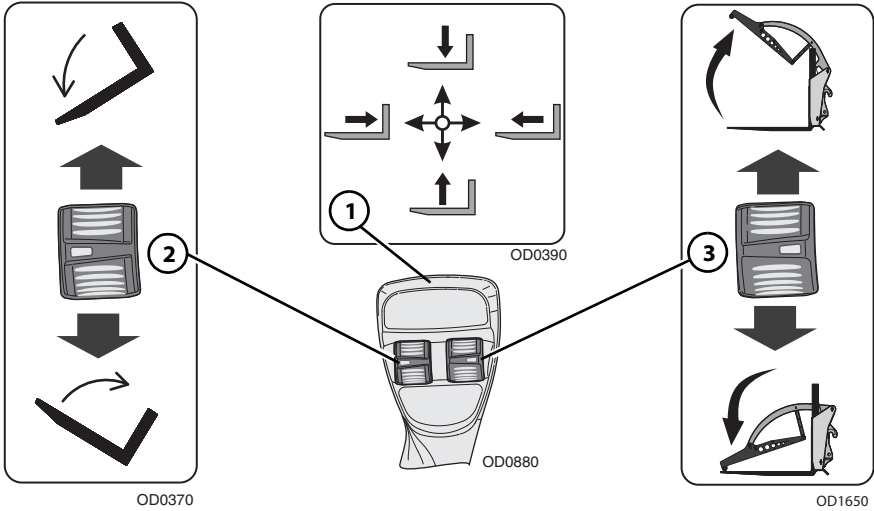

Joystick (1) controls movement of the boom.

Roller switch (2) controls pipe grapple tilt.

- Press roller switch down to tilt up.
- Press roller switch up to tilt down.

#### To Open/Close Pipe Grapple:

Roller switch (3) controls the open/close movement of the pipe grapple.

- Press roller switch down to close grapple.
- Press roller switch up to open grapple.

### **Installation Procedure:**

- Refer to “Attachment Installation” on page 5-9.

### **Operation:**

- Raise or lower boom to appropriate height and open pipe grapple for loading material.
- Align and center telehandler with face of material.
- Drive slowly and smoothly into material for loading. Boom extension may be required for loading material.
- Center load on forks, tilt forks up far enough to retain load, close pipe grapple and back away.
- Travel in accordance with requirements set forth in Section 1- General Safety Practices.
- Open pipe grapple and unload material from forks.

### **Equipment Damage Precautions**

- Except for lifting or unloading material, the boom must be fully retracted for all operations.
- Do not use forks as a lever to pry material. Excessive prying forces could damage forks or machine structure.
- Do not use pipe grapple as a lever to pry material. Excessive prying forces could damage pipe grapple or machine structure.
- Do not attempt to load material which is hard or frozen. This could cause severe damage to coupler or machine structure.
- Do not attempt to lift loads that are attached or connected to another object.

## Section 5- Attachments

### Fork Extension

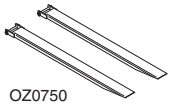

Use Appropriate Carriage Attachment Capacity Chart

To determine maximum capacity, refer to *“Telehandler/Attachment/Fork Capacity”* on page 5-4. The maximum capacity of the carriage when equipped with fork extensions may be reduced to the capacity indicated on the fork extensions. If the load exceeds the capacity of the fork extension, contact the local Caterpillar dealer to obtain forks and/or fork extensions of the proper load rating and length.

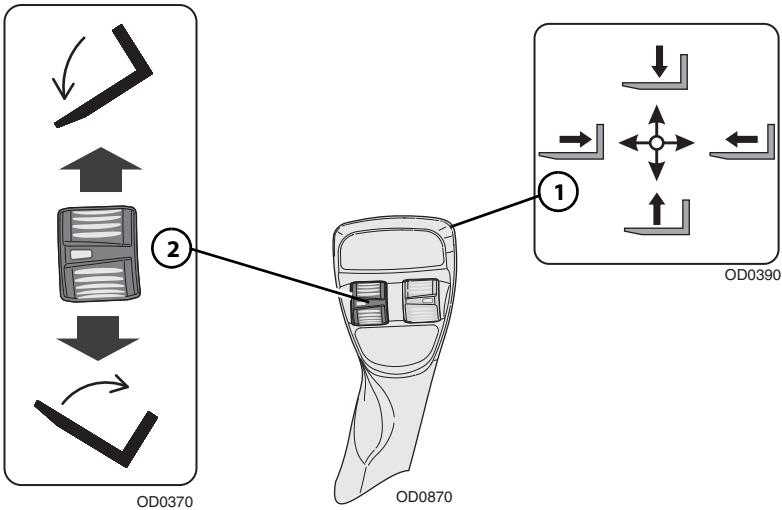

Joystick (1) controls movement of the boom.

Roller switch (2) controls carriage tilt.

- Press roller switch down to tilt up.
- Press roller switch up to tilt down.

### **Installation Procedure:**

- Ensure carriage is properly installed. Refer to “Attachment Installation” on page 5-9.
- Ensure length and cross section of the parent fork arm is equal to or exceeds the parent fork arm blade length stamped into the fork extension.
- Secure the fork extensions to the forks by sliding the fork extensions onto the parent forks and install the retaining pin behind the vertical shank of the fork.

### **Operation:**

- Heavy part of load must be against carriage backrest.
- Do not allow load center of gravity to be in front of tip of the supporting fork.
- Do not pick up a load or pry materials with tip of fork extensions.

## Section 5- Attachments

### Bucket

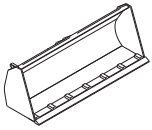

OZ0730

Use Appropriate Bucket Capacity Chart

To determine maximum capacity, refer to "Telehandler/Attachment/  
Fork Capacity" on page 5-4.

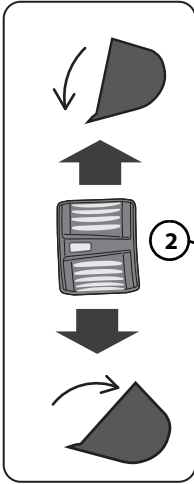

OD0460

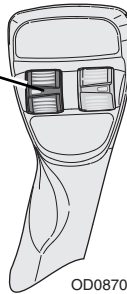

OD0870

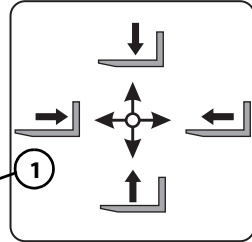

OD0390

Joystick (1) controls movement of the boom.

Roller switch (2) controls bucket tilt.

- Press roller switch down to tilt up.
- Press roller switch up to tilt down.

### **Installation Procedure:**

- Refer to “Attachment Installation” on page 5-9.

### **Operation:**

- Raise or lower boom to appropriate height for loading material from stockpile.
- Align telehandler with face of stockpile and drive slowly and smoothly into pile to load bucket.
- Tilt bucket up far enough to retain load and back away from pile.
- Travel in accordance with requirements set forth in Section 1- General Safety Practices.
- Tilt bucket down to dump load.

### **Equipment Damage Precautions**

- Except for lifting or dumping a load, the boom must be fully retracted for all bucket operations.
- Do not corner-load bucket. Distribute material evenly within the bucket. Bucket capacity charts are for evenly distributed loads only.
- Do not use bucket as a lever to pry material. Excessive prying forces could damage bucket or machine structure.
- Do not attempt to load material which is hard or frozen. This could cause severe damage to coupler or machine structure.
- Do not use bucket for "back dragging." This could cause severe damage to coupler and retraction cables/chains.

## Section 5- Attachments

### Multipurpose Bucket

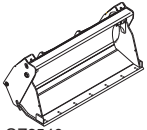

OZ2540

Use Multipurpose Bucket Capacity Chart

To determine maximum capacity, refer to "Telehandler/Attachment/  
Fork Capacity" on page 5-4.

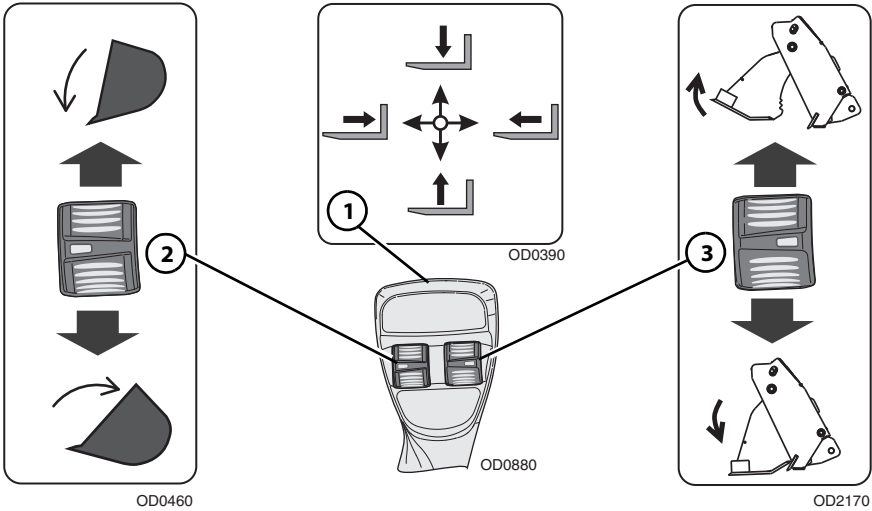

Joystick (1) controls movement of the boom.

Roller switch (2) controls bucket tilt.

- Press roller switch down to tilt up.
- Press roller switch up to tilt down.

#### To Open/Close Bucket:

Roller switch (3) controls the open/close movement of the bucket.

- Press roller switch down to close bucket.
- Press roller switch up to open bucket.



### **Installation Procedure:**

- Refer to "Attachment Installation" on page 5-9.

### **Operation:**

- Raise or lower boom to appropriate height and close bucket for loading material from stockpile.
- Align telehandler with face of stockpile and drive slowly and smoothly into pile to load bucket.
- Tilt bucket up far enough to retain load and back away from pile.
- Travel in accordance with requirements set forth in Section 1- General Safety Practices.
- Open bucket or tilt bucket down to dump load.

### **Equipment Damage Precautions**

- Except for lifting or dumping a load, the boom must be fully retracted for all bucket operations.
- Do not corner-load bucket. Distribute material evenly within the bucket. Bucket capacity charts are for evenly distributed loads only.
- Do not use bucket as a lever to pry material. Excessive prying forces could damage bucket or machine structure.
- Do not attempt to load material which is hard or frozen. This could cause severe damage to coupler or machine structure.
- Do not use bucket for "back dragging." This could cause severe damage to coupler and retraction cables/chains.

## Section 5- Attachments

### Grapple Bucket



OZ1450

Use Grapple Bucket Capacity Chart

To determine maximum capacity, refer to "Telehandler/Attachment/Fork Capacity" on page 5-4.

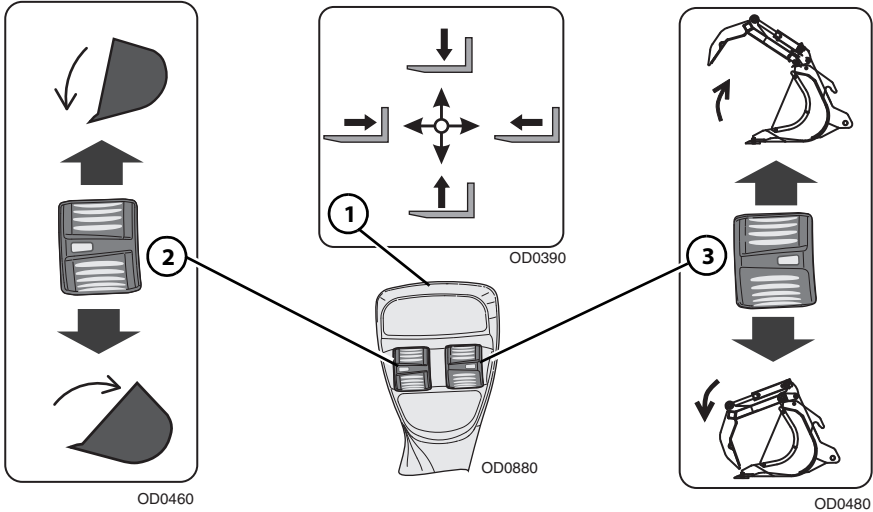

Joystick (1) controls movement of the boom.

Roller switch (2) controls grapple bucket tilt.

- Press roller switch down to tilt up.
- Press roller switch up to tilt down.

#### To Open/Close Grapple:

Roller switch (3) controls the open/close movement of the grapple.

- Press roller switch down to close grapple.
- Press roller switch up to open grapple.

### **Installation Procedure:**

- Refer to "Attachment Installation" on page 5-9.

### **Operation:**

- Raise or lower boom to appropriate height and open grapple for loading material from stockpile.
- Align telehandler with face of stockpile and drive slowly and smoothly into pile to load bucket.
- Tilt bucket up far enough to retain load, close grapple and back away from pile.
- Travel in accordance with requirements set forth in Section 1- General Safety Practices.
- Open grapple and tilt bucket down to dump load.

### **Equipment Damage Precautions**

- Except for lifting or dumping a load, the boom must be fully retracted for all bucket operations.
- Do not corner-load bucket. Distribute material evenly within the bucket. Bucket capacity charts are for evenly distributed loads only.
- Do not use bucket as a lever to pry material. Excessive prying forces could damage bucket or machine structure.
- Do not attempt to load material which is hard or frozen. This could cause severe damage to coupler or machine structure.
- Do not use bucket for "back dragging." This could cause severe damage to coupler and retraction cables/chains.

## Section 5- Attachments

### Trash Hopper - Fork Mounted

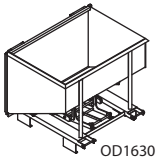

Use Appropriate Trash Hopper Capacity Chart

To determine maximum capacity, refer to *“Telehandler/Attachment/  
Fork Capacity”* on page 5-4.

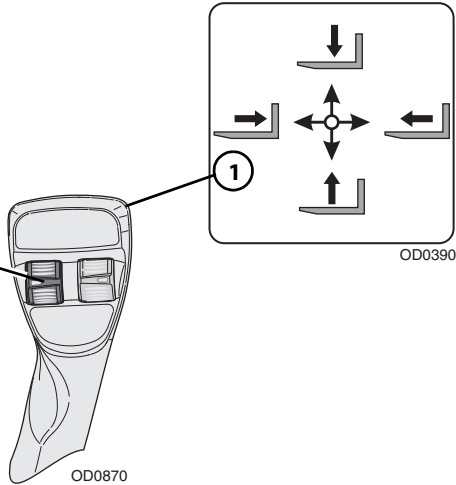
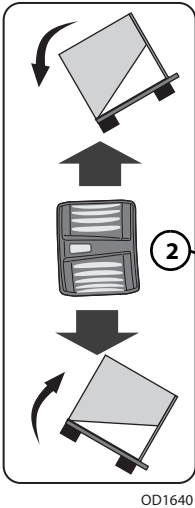

Joystick (1) controls movement of the boom.

Roller switch (2) controls trash hopper tilt.

- Press roller switch down to tilt up.
- Press roller switch up to tilt down.

### **Installation Procedure:**

- Ensure carriage is properly installed. Refer to “Attachment Installation” on page 5-9.
- Secure the fork mounted trash hopper to the forks by sliding the fork mounted trash hopper onto the parent forks and install the retaining pin behind the vertical shank of the fork.

### **Operation:**

- Raise or lower boom to appropriate height for loading material.
- Travel in accordance with requirements set forth in Section 1- General Safety Practices.
- To release gate, tilt fork mounted trash hopper down approximately 10 degrees and engage bottom bumper on edge of dumpster. The gate will open allowing the contents to slide out.
- Tilt fork mounted trash hopper back to close and secure the gate.
- Do not use with mast carriage attachment.
- Do not use fork mounted trash hopper with attachments capable of rotating (i.e. side tilt carriages) without disabling the rotation feature(s).

### **Equipment Damage Precautions**

- Except for lifting or dumping a load, the boom must be fully retracted for all fork mounted trash hopper operations.

## Section 5- Attachments

### Coupler Mounted Hook



Use Appropriate Coupler Mounted Hook Capacity Chart

To determine maximum capacity, refer to "Telehandler/Attachment/  
Fork Capacity" on page 5-4.

**Suspend loads in accordance with requirements set forth in Section 1- General Safety Practices.**

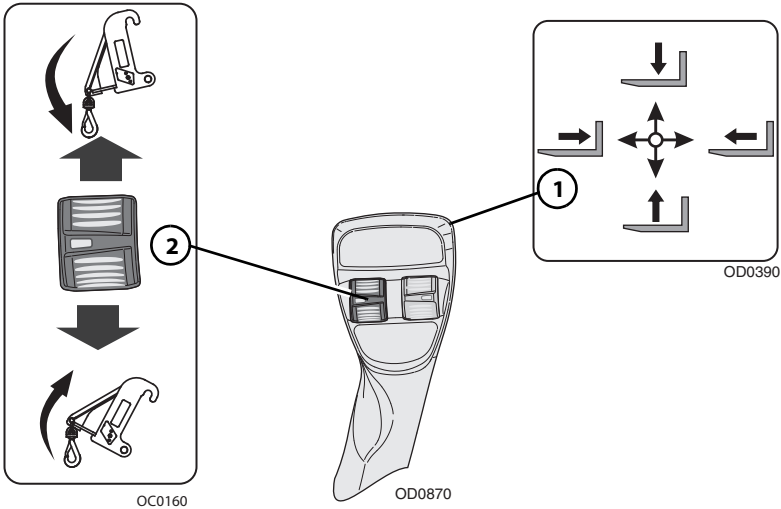

Joystick (1) controls movement of the boom.

Roller switch (2) controls coupler mounted hook tilt.

- Press roller switch down to tilt up.
- Press roller switch up to tilt down.

**Installation Procedure:**

- Refer to “Attachment Installation” on page 5-9.

**Operation:**

- Weight of rigging must be included as part of total load being lifted.

## Section 5- Attachments

### Fork Mounted Hook

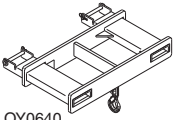

Use Appropriate Carriage Attachment Capacity Chart

To determine maximum capacity, refer to "Telehandler/Attachment/Fork Capacity" on page 5-4.

**Suspend loads in accordance with requirements set forth in Section 1- General Safety Practices.**

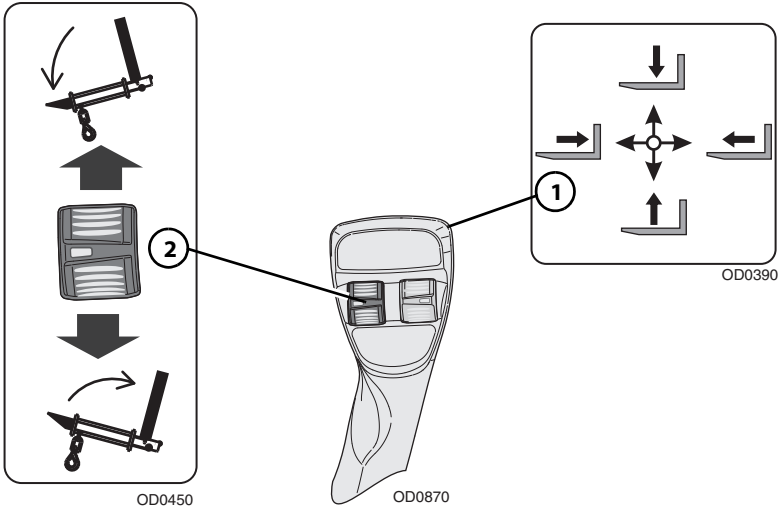

Joystick (1) controls movement of the boom.

Roller switch (2) controls carriage tilt.

- Press roller switch down to tilt up.
- Press roller switch up to tilt down.



### **Installation Procedure:**

- Ensure carriage is properly installed. Refer to “Attachment Installation” on page 5-9.
- Secure the fork mounted hook to the forks by sliding the fork mounted hook onto the parent forks and install the retaining pin behind the vertical shank of the fork.

### **Operation:**

- Pallet or lumber forks of an appropriate load rating must be used. Do not use with cubing or block forks.
- Fork mounted hook and rigging weight must be included as part of total load being lifted.
- Do not use with mast carriage attachment.
- Do not use fork mounted hook with attachments capable of rotating (i.e. side tilt and swing carriages) without disabling the rotation feature(s).

## Section 5- Attachments

### Truss Boom

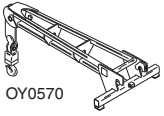

Use Appropriate Truss Boom Attachment Capacity Chart

To determine maximum capacity, refer to "Telehandler/Attachment/Fork Capacity" on page 5-4.

**Suspend loads in accordance with requirements set forth in Section 1- General Safety Practices.**

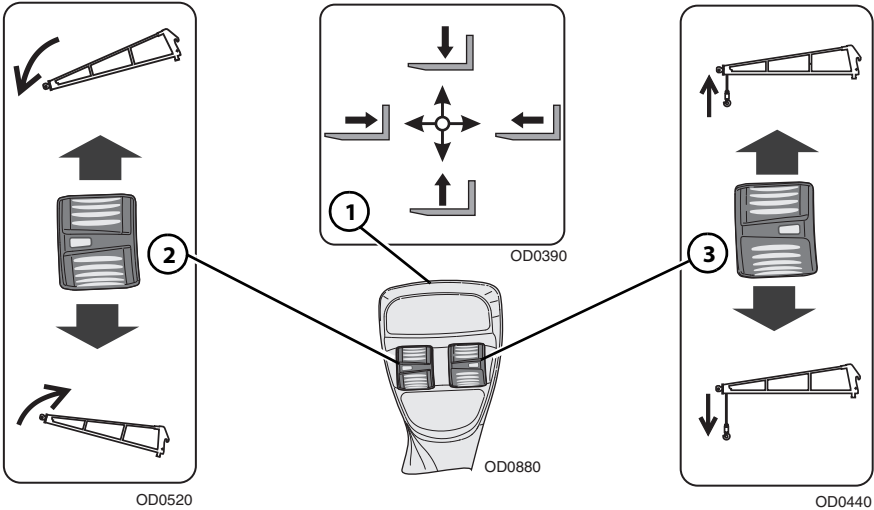

Joystick (1) controls movement of the boom.

Roller switch (2) controls truss boom tilt.

- Press roller switch down to tilt up.
- Press roller switch up to tilt down.

#### **Winch Control (if equipped):**

Roller switch (3) controls truss boom mounted winch.

- Press roller switch down to lower cable.
- Press roller switch up to raise cable.

**Installation Procedures**

- Refer to “Attachment Installation” on page 5-9.



**WARNING**

**CRUSH HAZARD.** Maintain a minimum of three wraps of wire rope on the cable drum at all times. Failure to comply could cause object or load to fall.

**Operation:**

- Weight of rigging must be included as part of total load being lifted.

## Section 5- Attachments

### Adjustable Truss Boom - Fork Mounted

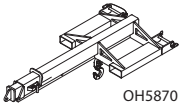

Use Appropriate Adjustable Truss Boom Attachment Capacity Chart

To determine maximum capacity, refer to "Telehandler/Attachment/  
Fork Capacity" on page 5-4.

**Suspend loads in accordance with requirements set forth in Section 1- General Safety Practices.**

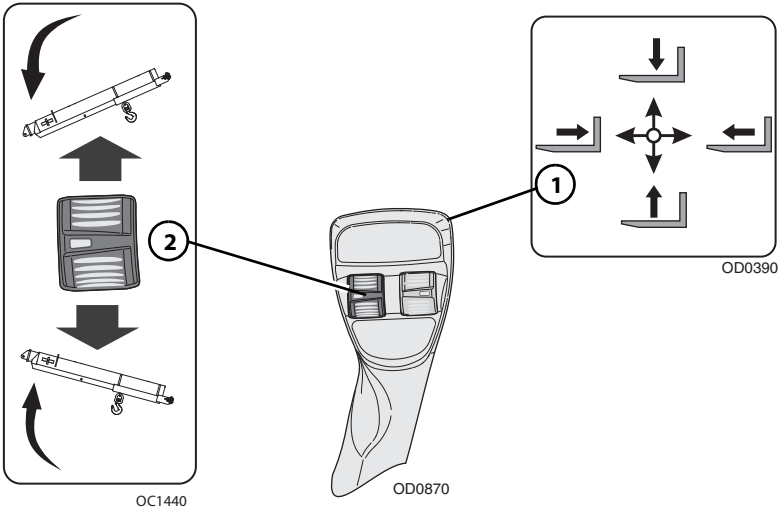

Joystick (1) controls movement of the boom.

Roller switch (2) controls adjustable truss boom tilt.

- Press roller switch down to tilt up.
- Press roller switch up to tilt down.

### Installation Procedures

- Ensure carriage is properly installed. Refer to “Attachment Installation” on page 5-9.
- Secure the adjustable truss boom to the forks by sliding the adjustable truss boom onto the parent forks and install the retaining pin behind the vertical shank of the fork.



## WARNING

**CRUSH HAZARD.** Ensure adjustable arm is properly secured using the retaining pin prior to lifting load. Failure to comply could cause object or load to fall.

### Operation:

- Pallet or lumber forks of an appropriate load rating must be used. Do not use with cubing or block forks.
- Weight of rigging must be included as part of total load being lifted.
- Do not use with mast carriage attachment.
- Do not use adjustable truss boom with attachments capable of rotating (i.e. side tilt and swing carriages) without disabling the rotation feature(s).

## Section 5- Attachments

### Material Handling Arm

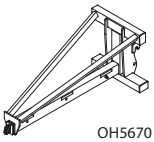

Use Appropriate Material Handling Arm Attachment Capacity Chart

To determine maximum capacity, refer to "Telehandler/Attachment/  
Fork Capacity" on page 5-4.

**Suspend loads in accordance with requirements set forth in Section 1- General Safety Practices.**

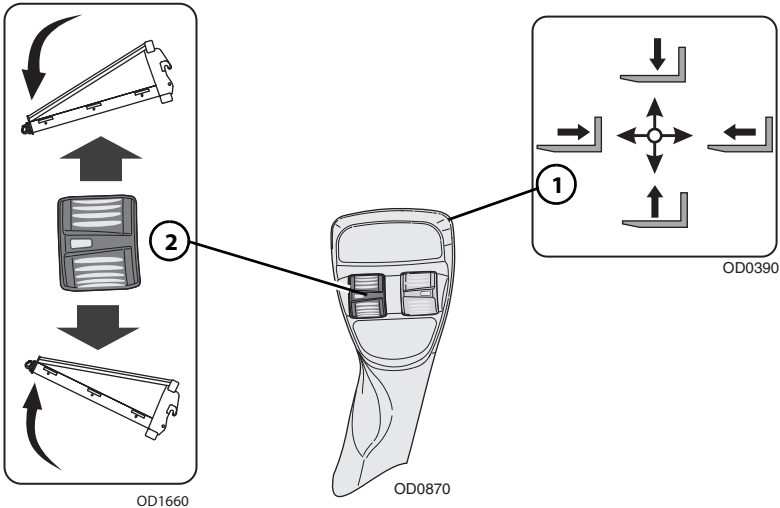

Joystick (1) controls movement of the boom.

Roller switch (2) controls material handling arm tilt.

- Press roller switch down to tilt up.
- Press roller switch up to tilt down.

**Installation Procedures**

- Refer to “Attachment Installation” on page 5-9.
- Secure adjustable arm in desired position using the retaining pin.



**WARNING**

**CRUSH HAZARD.** Ensure adjustable arm is properly secured using the retaining pin prior to lifting load. Failure to comply could cause object or load to fall.

**Operation:**

- Weight of rigging must be included as part of total load being lifted.

## Section 5- Attachments

### Personnel Work Platform - Fork Mounted

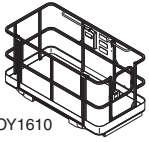

OY1610

For fork mounted platforms utilized on machines built to the B56.6-2011 Standard or older, use Appropriate Carriage Attachment Capacity Chart

For fork mounted platforms utilized on machines built to the B56.6-2016 Standard, use Fork Mounted Platform Attachment Capacity Chart

To determine maximum capacity, refer to *"Telehandler/Attachment/Fork Capacity"* on page 5-4.

**The operator and personnel in platform must read and understand the separate personnel work platform manual prior to installing and using a platform.**

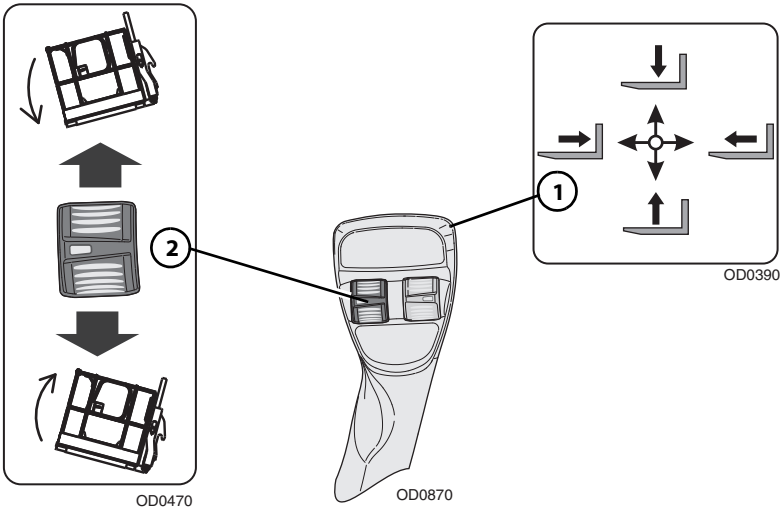

Joystick (1) controls movement of the boom.

Roller switch (2) controls platform tilt.

- Press roller switch down to tilt up.
- Press roller switch up to tilt down.



### Installation Procedure:

- Ensure carriage is properly installed. Refer to "Attachment Installation" on page 5-9.
- Secure the fork mounted platform to the forks by sliding the fork mounted platform onto the parent forks and install the retaining pin behind the vertical shank of the fork.

### Preparation and Setup:

1. Ensure the telehandler is on a firm surface and is level.
2. Engage the park brake. Blocking the wheels is also recommended.
3. Level the platform, both side to side (frame level) and front to back (attachment tilt).
4. Keep area under platform free from personnel.
5. When personnel are on platform, the operator must remain seated in cab with personnel in direct line of sight.
6. **DO NOT** lift or carry persons in a bucket or on forks.



## WARNING

**FALL HAZARD.** Never tilt the platform forward, rearward, or level the machine when the platform is occupied.

## Section 5- Attachments

### Sweeper

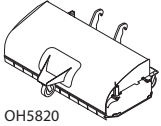

OH5820

Use Sweeper Capacity Chart

To determine maximum capacity, refer to "Telehandler/Attachment/Fork Capacity" on page 5-4.

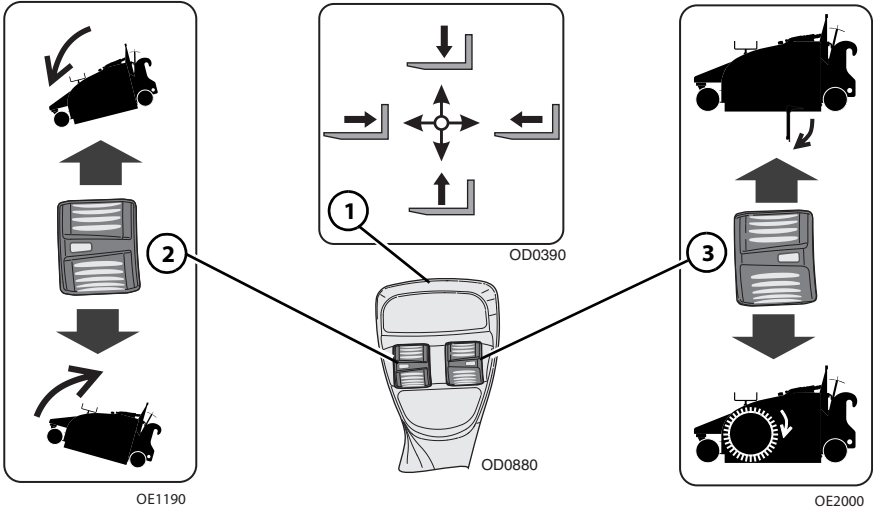

Joystick (1) controls movement of the boom.

Roller switch (2) controls sweeper tilt.

- Press roller switch down to tilt up.
- Press roller switch up to tilt down.

#### To Control Sweeper:

Roller switch (3) controls the sweeper.

- Press roller switch down to close hopper and engage sweeper brushes.
- Press roller switch up to open hopper.

### To Enable/Disable Continuous Operation of Sweeper Brushes:

- With transmission in neutral, press and hold continuous auxiliary hydraulics switch on left dash control panel.
- Press roller switch (3) down to engage sweeper brushes.
- Release continuous auxiliary hydraulics switch and roller switch (3) to enable continuous operation of sweeper brushes.
- To disable continuous operation of sweeper brushes, press continuous auxiliary hydraulics switch again.

### Installation Procedure:

- Refer to "Attachment Installation" on page 5-9.



## WARNING

**CRUSH HAZARD.** Remove large objects in path of sweeper before operating. Failure to comply could cause object to be thrown by sweeper.

### Operation:

- Place sweeper on a level area. Fully retract boom and lower until all three sweeper wheels are in contact with the ground.
- Using height and angle gauge on the sweeper, obtain the central mid-float position to obtain best sweeping operation.
- Operate roller switch (3) to engage sweeper brushes.
- Sweep a path less than the width of the sweeper.
- Travel in accordance with requirements set forth in Section 1- General Safety Practices.
- To empty hopper, raise sweeper over desired dump area ensuring proper clearance. Operate roller switch (3) to open the hopper allowing the contents to slide out. Close the hopper after all contents are removed.

### Equipment Damage Precautions

- Except for emptying hopper, the boom must be fully retracted for all sweeper operations.
- Avoid excessive downward pressure on brushes when sweeping.
- Do not store sweeper with weight on brushes. Place on blocks or storage stands.

## Section 5- Attachments

### Boom Mounted Lifting Lug

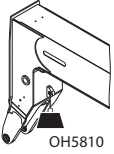

Use Boom Mounted Lifting Lug Capacity Chart

To determine maximum capacity, refer to "Telehandler/Attachment/Fork Capacity" on page 5-4.

**Suspend loads in accordance with requirements set forth in Section 1- General Safety Practices.**

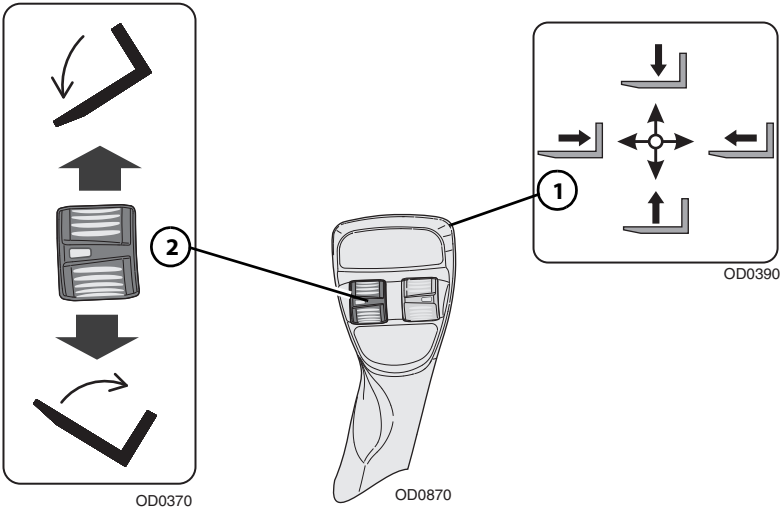

Joystick (1) controls movement of the boom.

Roller switch (2) controls carriage tilt.

- Press roller switch down to tilt up.
- Press roller switch up to tilt down.



## WARNING

**TIP OVER HAZARD.** No load may be on attachment when lifting load with boom mounted lifting lug. Failure to comply could cause tip over.

### Operation:

- Weight of rigging must be included as part of total load being lifted.

## **SECTION 6 - EMERGENCY PROCEDURES**

---

### **6.1 TOWING A DISABLED PRODUCT**

**The following information assumes telehandler cannot be moved under its own power.**

- Before moving the telehandler, read all of the following information to understand options available. Then select the appropriate method.
- Machine mounted retrieval devices provide suitable means to attach a tow rope, chain or tow bar only in the event the telehandler becomes stuck or disabled.
- Retrieval devices are not intended for on-road trailer towing applications.
- The steering system permits manual steering if engine or power assist feature fails; however, **steering will be slow and will require much greater force.**
- **DO NOT** attempt to tow a telehandler that is loaded or the boom/attachment is raised above 4 ft (1,2 m).

### **Moving Short Distances**

---

- If it is only necessary to move telehandler a short distance, less than 30 m (100 ft), it is permissible to use a vehicle of sufficient capacity to tow the unit with no previous preparation.

### **Moving Longer Distance**

---

- See Service Manual for information.
- Dependant on local regulations the appropriate machine Service Manual should be kept in the cab at all times.

**Contact the local Caterpillar dealer for specific instructions if neither of these methods are applicable.**

## ***Section 6- Emergency Procedures***

---

### **6.2 EMERGENCY LOWERING OF BOOM**

In the event of total loss of engine power or hydraulic pump failure with an elevated load, the situation must be properly evaluated and dealt with on an individual basis. **Contact the local Caterpillar dealer for specific instructions.**

Secure the telehandler using the following procedures:

1. If equipped with platform attachment, rescue platform occupants.
2. Clear the area around telehandler of all personnel.
3. Apply the parking brake. Place the transmission in "NEUTRAL".
4. Block all four wheels.
5. Section off a large area under the boom to restrict any personnel from entering this area.
6. See Service Manual for information.

### 6.3 EMERGENCY EXIT FROM ENCLOSED CAB

In an emergency the rear window can be used to exit the telehandler.

#### Inside Cab

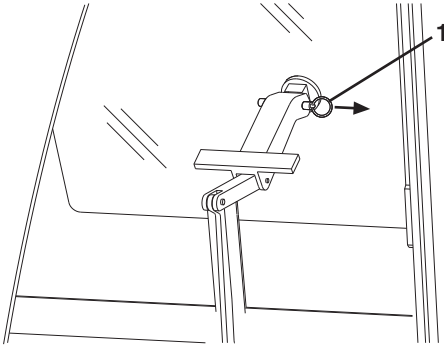

OZ0240

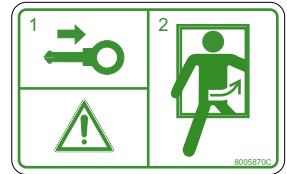

OE0751

- Remove the latch pin (1). The window is then free to swing open.

#### Outside Cab (if equipped)

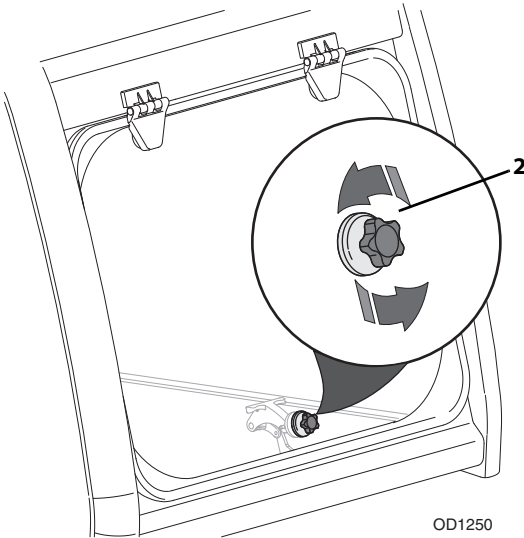

OD1250

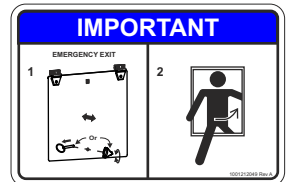

OC0721

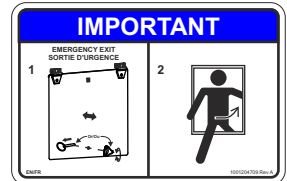

OE0761

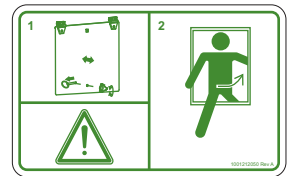

OC1280

- Remove the knob (2) securing window. The window is then free to swing open.

**This Page Intentionally Left Blank**



## SECTION 7 - LUBRICATION AND MAINTENANCE

### 7.1 INTRODUCTION

This section is intended as information to assist the operator to perform maintenance tasks only. Service product in accordance with maintenance schedule on the following pages.

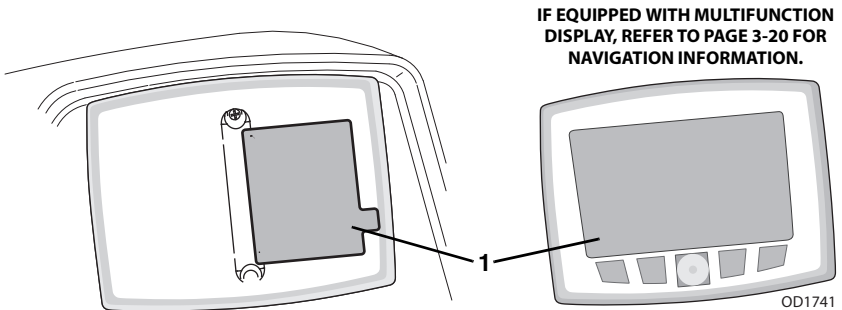

Lubrication and maintenance charts (1) contain instructions that must be followed to keep this product in good operating condition. Operation & Maintenance Manual and Service Manual contain more detailed service information with specific instructions. If equipped with Multifunction Display, refer to page 3-27 for navigation information.

### Clothing and Safety Gear

- Wear all protective clothing and personal safety devices issued to you or called for by job conditions
- **DO NOT** wear loose clothing or jewelry that can get caught on controls or moving parts

## Section 7- Lubrication and Maintenance

---

### 7.2 GENERAL MAINTENANCE INSTRUCTIONS

**Prior to performing any service or maintenance on the telehandler, follow the shut-down procedure on page 4-5 unless otherwise instructed. Ensure telehandler is level, for proper fluid readings.**

- Clean lubrication fittings before lubricating.
- After greasing telehandler, cycle all functions several times to distribute lubricants. Perform this maintenance procedure without attachment installed.
- Apply a light coating of engine oil to all linkage pivot points.
- Intervals shown are for normal usage and conditions. Adjust intervals for abnormal usage and conditions.
- Check all lubricant levels when lubricant is cool, with the exception of the transmission fluid. For ease of filling hydraulic reservoir, use a funnel with a hose or flexible tube for best results.



## WARNING

**CUT/CRUSH/BURN HAZARD.** Do not perform service or maintenance on the machine with engine running with the exception of transmission fluid level check.

### 7.3 MAINTENANCE SCHEDULES

**Note:** If hour and year intervals are listed, perform maintenance at interval that occurs first.

#### Every 10 Hours



OC0880

Check Fuel Level



OC0890

Check Tire  
Condition and  
Pressure

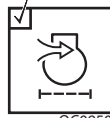

OC0950

Check Air Cleaner



OC0910

Check Engine Oil  
Level

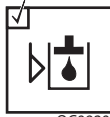

OC0920

Check Hydraulic  
Oil Level

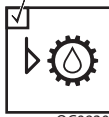

OC0930

Check  
Transmission Oil  
Level



OC0940

Check DEF Level  
(SN ML800150 to Present  
SN MLJ00150 to Present  
SN ML500150 to Present  
SN ML700150 to Present)

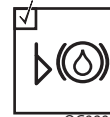

OC0900

Check Brake  
Reservoir Level



OC0980

Additional Checks  
(see Section 8)

#### First 50 Hours

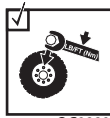

OC0990

Check Wheel Lug  
Nut Torque



OC1000

Check Boom Chain  
Tension

## Section 7- Lubrication and Maintenance

---

### Every 50 Hours

---



Lubrication  
Schedule

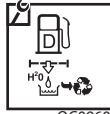

Drain Fuel/Water  
Separator



Check Engine  
Coolant Level

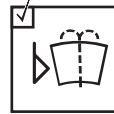

Check Washer  
Fluid



Check Cab Filter

### First 250 Hours

---



Change Axle Oil

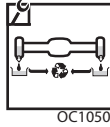

Change Wheel End  
Oil

### Every 250 Hours

---



Lubrication  
Schedule



Check Boom  
Chains

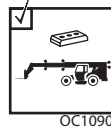

Check Boom Wear  
Pads

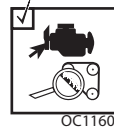

Check Fan Belt



Check Transfer  
Case Fluid Level

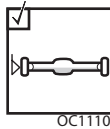

Check Axle Oil  
Level

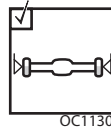

Check Wheel End  
Oil Level

**First 500 Hours or 1 Year**

---



Change  
Transmission Fluid  
and Filter

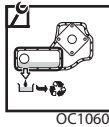

Change Transfer  
Case Fluid

**Every 500 Hours**

---



Change Fuel Filters



Check Wheel Lug  
Nut Torque

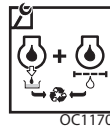

Change Engine Oil  
and Filter

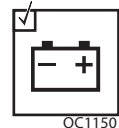

Check Battery



Check RAS System

**Every 750 Hours**

---



Change Hydraulic  
Tank Breather



Change Hydraulic  
Filters

## Section 7- Lubrication and Maintenance

---

### Every 1000 Hours

---



OC1000

Check Boom Chain  
Tension

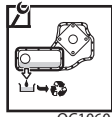

OC1060

Change Transfer  
Case Fluid



OC1200

Check Air Intake  
System

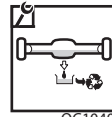

OC1040

Change Axle Oil

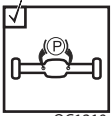

OC1210

Check Park Brake



OC1070

Change  
Transmission Fluid  
and Filter

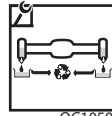

OC1050

Change Wheel End  
Oil

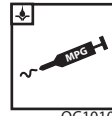

OC1010

Lubrication  
Schedule

### Every 1500 Hours

---



OC1260

Change DEF Pump  
Filter

(SN ML800150 to Present  
SN MLJ00150 to Present  
SN ML500150 to Present  
SN ML700150 to Present)



OC1240

Change Engine  
Coolant

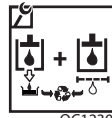

OC1230

Change Hydraulic  
Fluid and Filters



OD2300

Change Crankcase  
Vent Filter

(SN ML800150 to Present  
SN MLJ00150 to Present  
SN ML500150 to Present  
SN ML700150 to Present)

### Every 2000 Hours

---



OC1250

Change DEF Tank  
Filter

(SN ML800150 to Present  
SN MLJ00150 to Present  
SN ML500150 to Present  
SN ML700150 to Present)

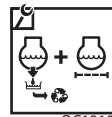

OC1310

Clean Engine DEF  
Strainer

(SN ML800150 to Present  
SN MLJ00150 to Present  
SN ML500150 to Present  
SN ML700150 to Present)

**This Page Intentionally Left Blank**

# Section 7- Lubrication and Maintenance

## 7.4 LUBRICATION SCHEDULES

### Every 50 Hours

TL642D, TL943D

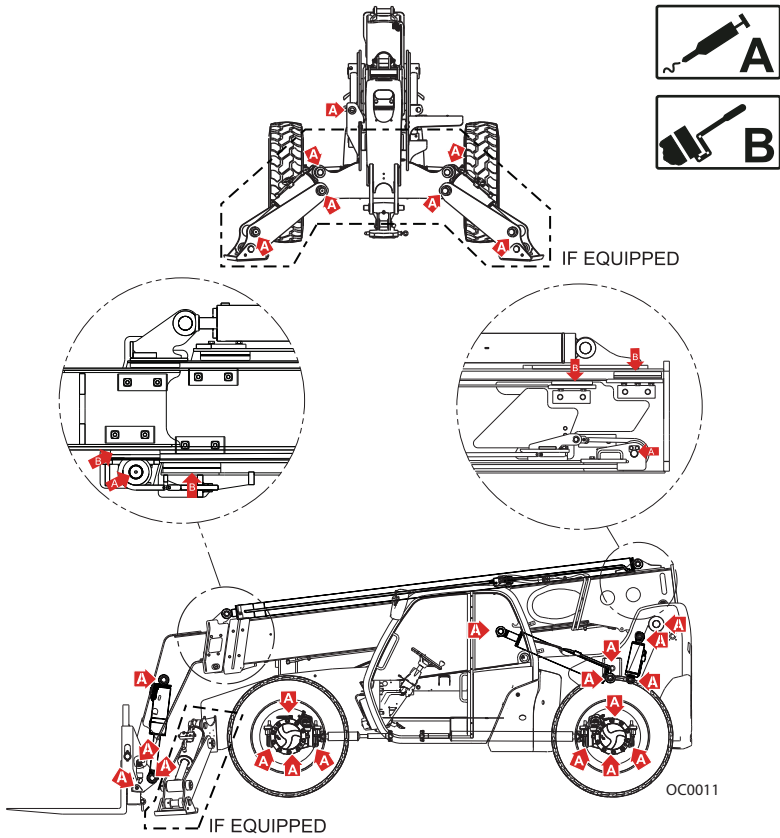



TL1055D, TL1255D

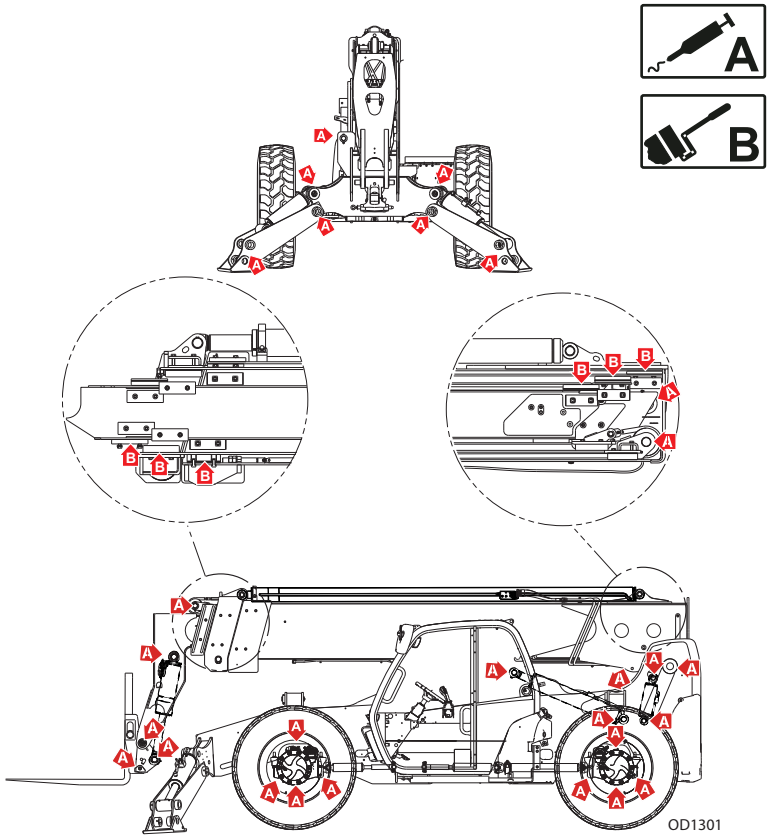

OD1301

# Section 7- Lubrication and Maintenance

## Every 250 Hours

TL642D, TL943D

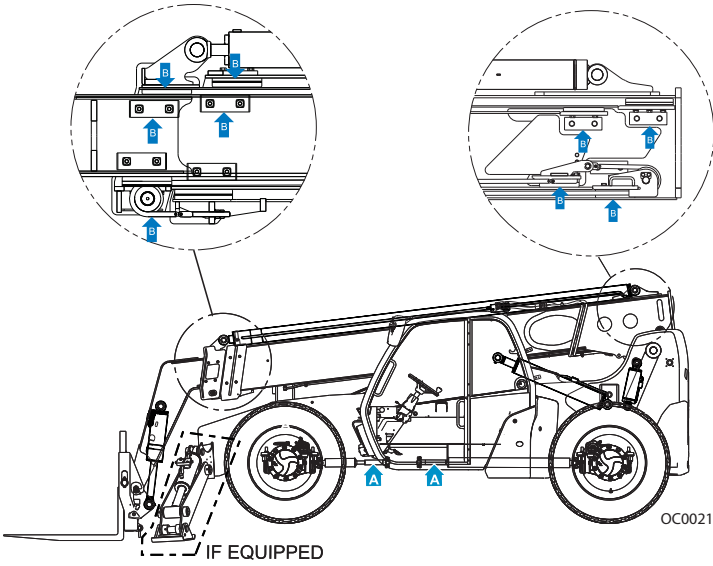
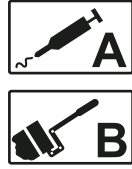

TL1055D, TL1255D

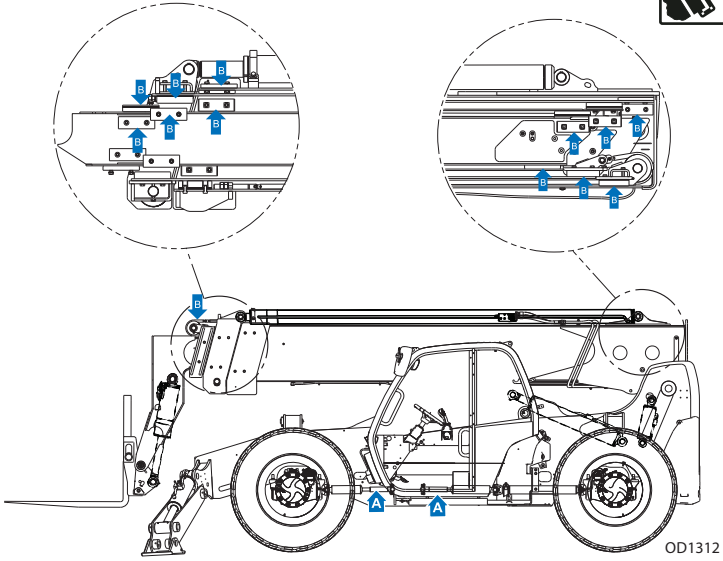

**Section 7- Lubrication and Maintenance**

**Every 1000 Hours**

TL642D, TL943D

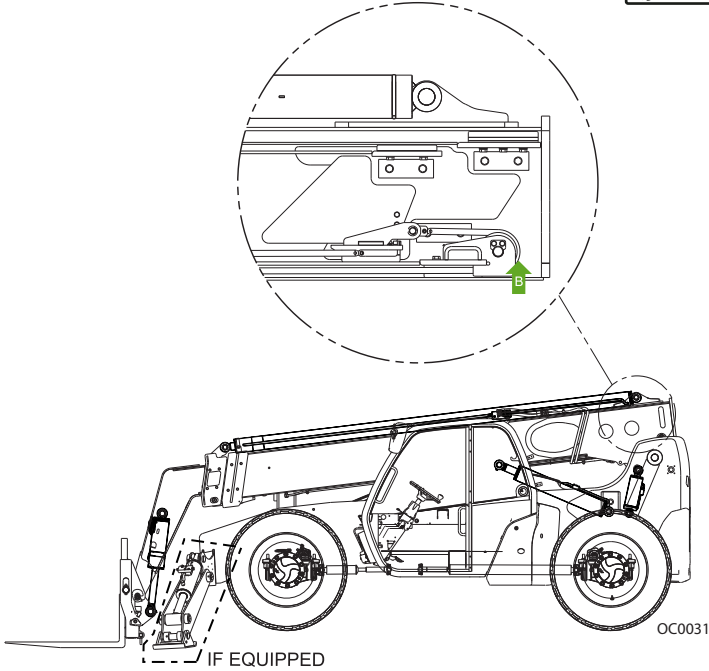

TL1055D, TL1255D

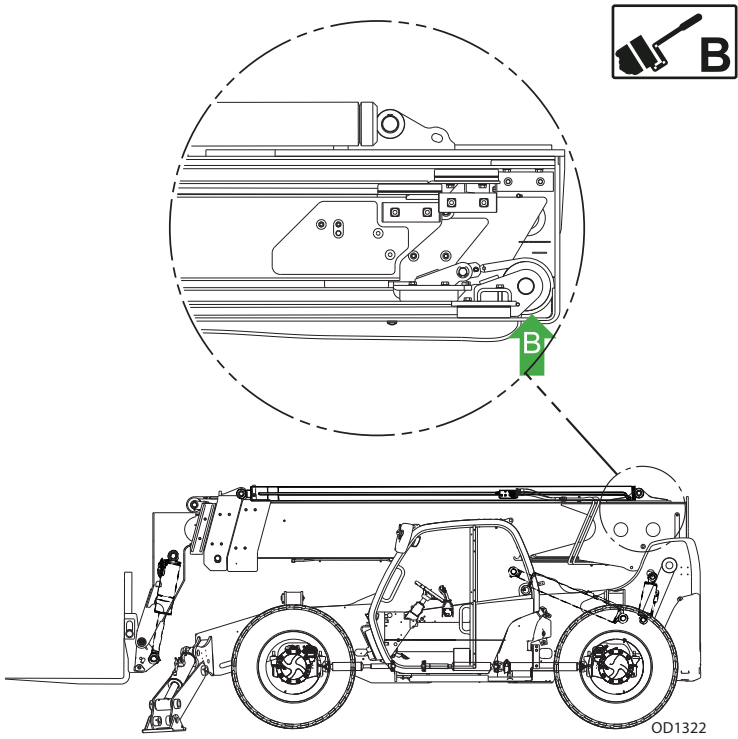

OD1322

## Section 7- Lubrication and Maintenance

---

### 7.5 OPERATOR MAINTENANCE INSTRUCTIONS

---

#### Engine Maintenance Components

---

SN ML800150 to Present, SN MLJ00150 to Present

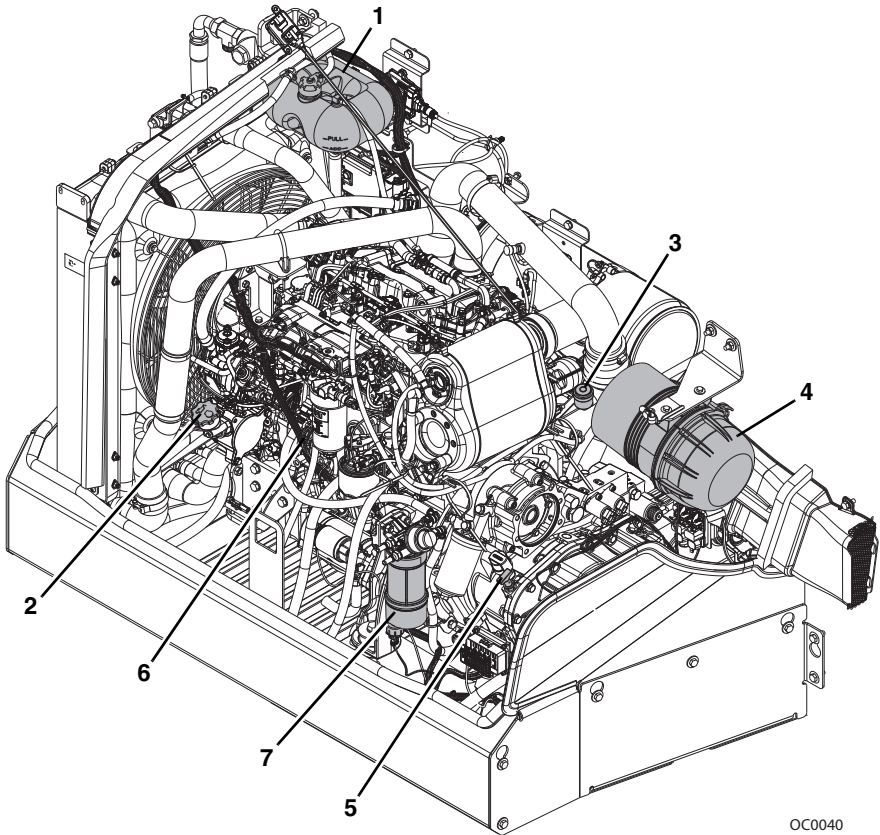

OC0040

1. **Surge Tank:** See page 7-30.
2. **Engine Oil Cap:** See page 7-21.
3. **Air Filter Restriction Indicator:** See page 7-22.
4. **Air Filter:** See page 7-22.
5. **Transmission Fluid Dipstick:** See page 7-26.
6. **Engine Oil Dipstick:** See page 7-21.
7. **Primary Fuel Filter:** See page 7-18.

**SN ML500150 to Present, SN ML700150 to Present**

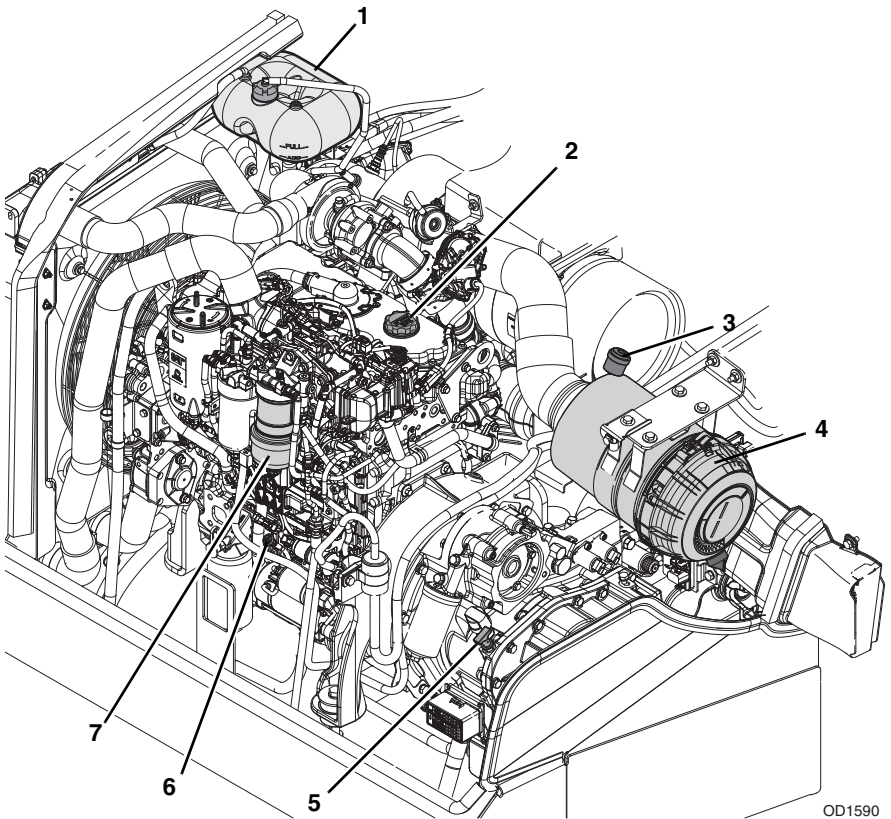

OD1590

- 1. Surge Tank:** See page 7-30.
- 2. Engine Oil Cap:** See page 7-21.
- 3. Air Filter Restriction Indicator:** See page 7-22.
- 4. Air Filter:** See page 7-22.
- 5. Transmission Fluid Dipstick:** See page 7-26.
- 6. Engine Oil Dipstick:** See page 7-21.
- 7. Primary Fuel Filter:** See page 7-18.

## Section 7- Lubrication and Maintenance

SN MLG00150 to Present, SN MLD00150 to Present, SN MNT00150 to Present,  
SN MYW00150 to Present

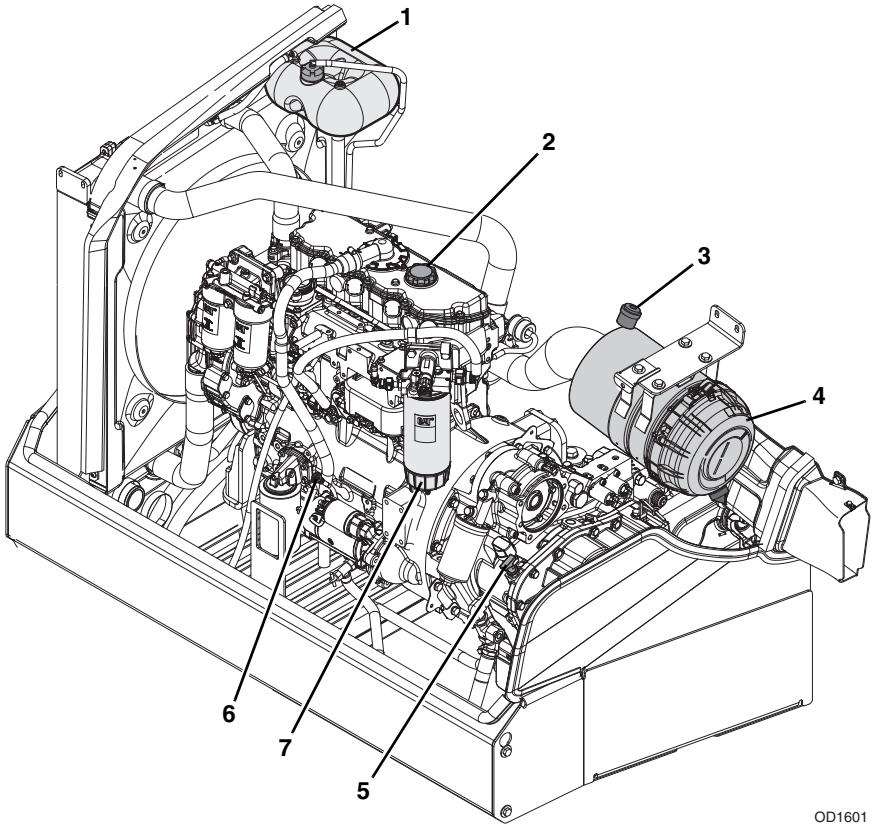

OD1601

1. **Surge Tank:** See page 7-30.
2. **Engine Oil Cap:** See page 7-21.
3. **Air Filter Restriction Indicator:** See page 7-22.
4. **Air Filter:** See page 7-22.
5. **Transmission Fluid Dipstick:** See page 7-26.
6. **Engine Oil Dipstick:** See page 7-21.
7. **Primary Fuel Filter:** See page 7-18.



**This Page Intentionally Left Blank**

## Section 7- Lubrication and Maintenance

### Fuel System

#### A. Fuel Level Check

10   
OW0970

  
OW0990

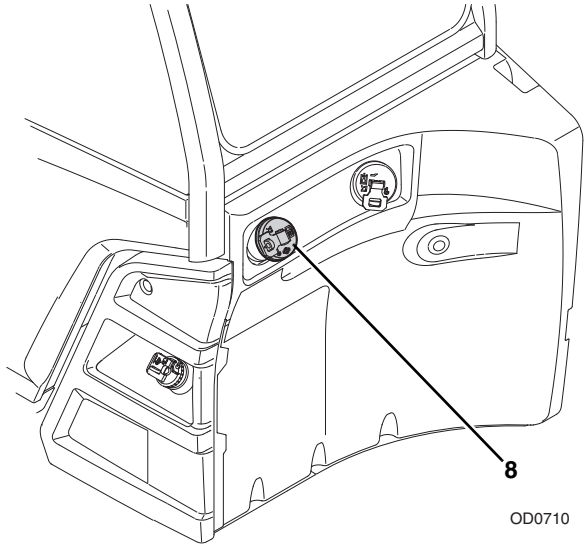
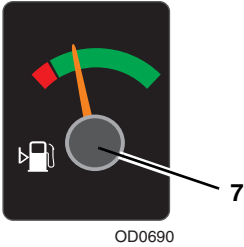

1. Check Fuel Gauge (7) located in right side of Instrument Panel in cab.
2. If fuel is low, proceed to fuel source and perform "Shut-Down Procedure" on page 4-5.
3. Turn fuel tank cap (8) to remove from filler neck.
4. Add fuel as needed.
5. Replace fuel tank cap.

**Note:** Replenish diesel fuel at end of each work shift to minimize condensation.

## NOTICE

**EQUIPMENT DAMAGE.** Do not allow machine to run out of fuel during operation. See Engine Operation & Maintenance Manual for details prior to servicing.

### B. Drain Fuel/Water Separator

50   
OW0980



SN ML800150 TO PRESENT  
SN MLJ00150 TO PRESENT

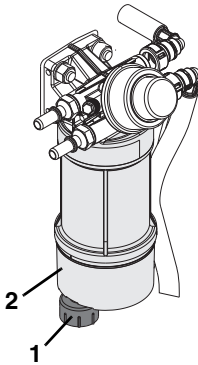

SN ML500150 TO PRESENT  
SN ML700150 TO PRESENT

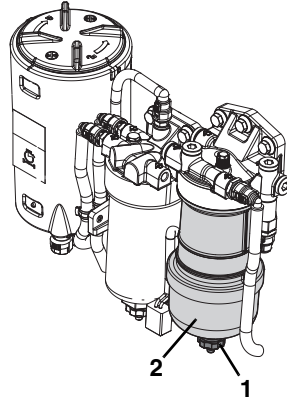

SN MLG00150 TO PRESENT, SN MLD00150 TO PRESENT,  
SN MNT00150 TO PRESENT, SN MYW00150 TO PRESENT

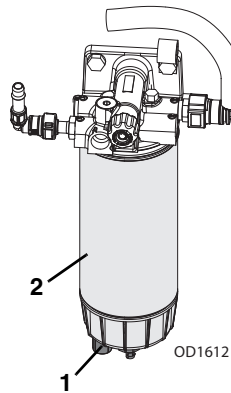

1. Perform "Shut-Down Procedure" on page 4-5.
2. Open engine cover.
3. Loosen drain cock (1) on underside of fuel filter (2) and allow all water to drain into a glass until clear fuel is visible. Tighten drain cock.
4. Close and secure engine cover.

## Section 7- Lubrication and Maintenance

### Emission System (SN ML800150 to Present, SN MLJ00150 to Present, SN ML500150 to Present, SN ML700150 to Present)

#### A. Diesel Emission Fluid (DEF) Level Check

10  
OW0970



OD1330

1

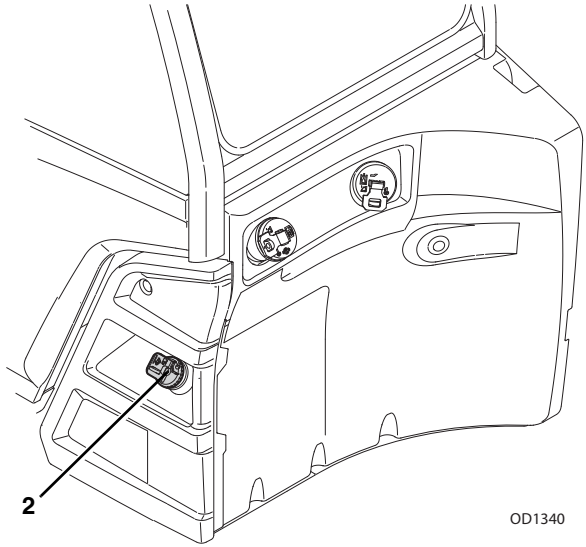

OD1340

1. Check Diesel Emission Fluid (DEF) Gauge (1) located in right side of Instrument Panel in cab.
2. If DEF is low, proceed to DEF source and perform "Shut-Down Procedure" on page 4-5.
3. Turn DEF tank cap (2) to remove.
4. Add DEF as needed.
5. Replace DEF tank cap.

## NOTICE

**EQUIPMENT DAMAGE.** Do not allow machine to run out of Diesel Emission Fluid (DEF) during operation. See the Engine Operation & Maintenance Manual for details prior to servicing.

### Engine Oil

#### A. Engine Oil Level Check

**10**   
OW0970

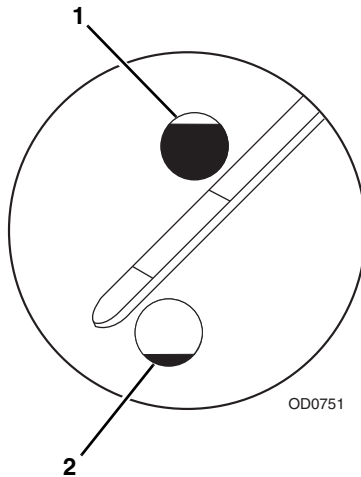

1. Perform "Shut-Down Procedure" on page 4-5.
2. Open engine cover.
3. Remove dipstick and check oil mark. Oil should be between full (1) and add (2) marks of dipstick.
4. Replace dipstick.
5. If oil is low, remove oil fill cap and add oil to bring oil up to full mark.
6. Replace oil fill cap.
7. Close and secure engine cover.

## Section 7- Lubrication and Maintenance

### Air Intake System

#### A. Air Cleaner Check

10   
OW0970

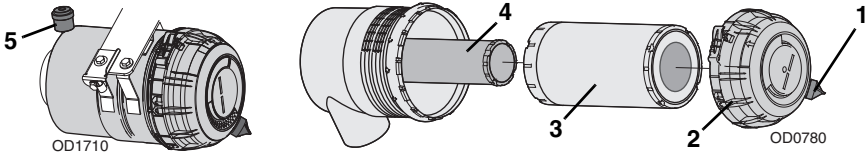

1. Perform "Shut-Down Procedure" on page 4-5.
2. Open engine cover.
3. Locate air cleaner and check restriction indicator (5). Primary element (3) must be replaced if red band is visible.
4. Remove dust from vacuator valve (1) by squeezing bottom of valve to allow loose particles to fall out.
5. Close and secure engine cover.

## NOTICE

**EQUIPMENT DAMAGE.** Only remove air cleaner cover to service elements. Excessive access to check elements can lead to premature element and/or engine failure.

### B. Element Change

**Note:** Change elements as air cleaner restriction indicator indicates or every two years. Use the interval that occurs first.

1. Perform "Shut-Down Procedure" on page 4-5.
2. Open engine cover.
3. Unlock air cleaner cover (2) and remove from air cleaner.
4. Remove outer primary element (3). Inspect element for damage then discard.
5. Thoroughly clean interior of air cleaner canister and vacuator valve.
6. Replace inner safety element (4) every third primary element change or if primary element was found to be damaged. If replacing inner safety element at this time, carefully slide element out and replace with new element.
7. Slide new primary element over inner safety element making sure sealing edge is flush with base of air cleaner.
8. Position air cleaner cover in place and lock into position.
9. Depress button on restriction indicator to reset.
10. Close and secure engine cover.

**Note:** Elements should never be washed or reused. Always install new elements.

# NOTICE

**EQUIPMENT DAMAGE.** Primary and safety elements are required to be replaced if used in an application longer than two years regardless of hours of operation.

## Section 7- Lubrication and Maintenance

---

### Tires

---

#### A. Tire Air Pressure Check



1. Perform “Shut-Down Procedure” on page 4-5.
2. Remove valve stem cap.
3. Check tire pressure.
4. Add air if required. See page 9-7 for tire pressures.
5. Replace valve stem cap.

#### B. Tire Damage

For pneumatic tires, when any cut, rip or tear is discovered that exposes sidewall or tread area cords in the tire, measures be taken to remove the product from service immediately. Arrangements must be made for replacement of the tire or tire assembly.

For polyurethane foam filled tires, when any of the following are discovered, measures must be taken to remove the product from service immediately. Arrangements must be made for replacement of the tire or tire assembly.

- Smooth even cut through the cord plies which exceeds 3 in (7,5 cm) in total length
- Any tears or rips (ragged edges) in cord plies which exceeds 1 in (2,5 cm) in any direction
- Any punctures which exceed 1 in (2,5 cm) in diameter

If a tire is damaged but within above noted criteria, tire must be inspected daily to ensure damage has not propagated beyond allowable criteria.

#### C. Tire and Wheel Replacement

It is recommended that a replacement tire to be same size, ply, inflation medium and brand as originally installed. Refer to appropriate parts manual for ordering information. If not using an approved replacement tire, replacement tires must have the following characteristics:

- Equal or greater ply/load rating and size of original
- Tire tread contact width equal or greater than original
- Wheel diameter, width and offset dimensions equal to the original
- Approved for application by tire manufacturer (including inflation pressure and maximum tire load)

Due to size variations between tire brands, when selecting and installing a replacement tire ensure both tires on the axle are the same.



## Section 7- Lubrication and Maintenance

The rims installed have been designed for stability requirements which consist of track width, tire pressure and load capacity. Size changes such as rim width, center piece location, larger or smaller diameter, etc., without written factory recommendations, may result in unsafe condition regarding stability.

### D. Wheel Installation

Torque lug nuts after first 50 hours and after each wheel installation.

**Note:** If machine is equipped with directional tire assemblies, wheel and tire assemblies must be installed with directional tread pattern "arrows" facing in direction of forward travel.

1. Start all nuts by hand to prevent cross threading. DO NOT use a lubricant on threads or nuts.

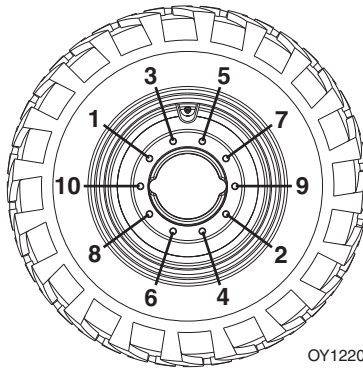

2. Tighten lug nuts in an alternating pattern as indicated in figure. See page 9-7 for torque value.



## WARNING

**TIP OVER HAZARD.** Lug nuts must be installed and maintained at the proper torque to prevent loose wheels, broken studs and possible separation of wheel from the axle.

## Section 7- Lubrication and Maintenance

### Transmission Oil

#### A. Transmission Oil Level Check

10   
OW0970

  
OW1050

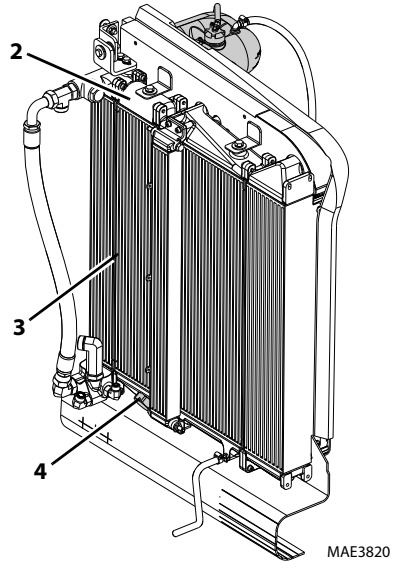
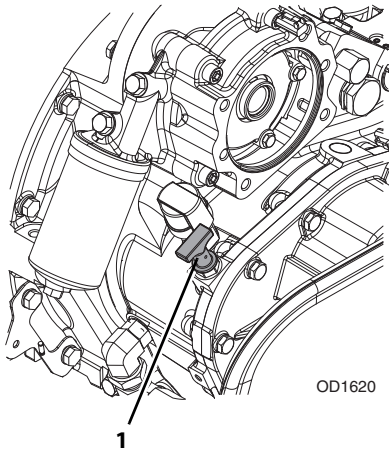

**Note:** Final transmission oil level must always be checked with engine at idle and transmission oil at operating temperature (minimum 80°C/176°F).

1. Start machine on a firm, level surface, level machine, fully retract boom, lower boom, place transmission in (N) Neutral, engage park brake and run engine at idle.
2. Open engine cover.
3. Remove transmission dipstick (1) and check oil level. The cold oil level after 2-3 minutes of idle must be above the HOT MIN line.

**Note:** Depending on the amount of fluid remaining in the transmission oil cooler, the oil level may read substantially above the HOT oil top level mark at this time. The correct oil level can be obtained after the transmission fluid is at operating temperature.

4. If oil is low, add oil as required.
5. Replace transmission dipstick.
6. Close and secure engine cover.
7. Ensure the front of the machine is clear of persons or obstacles.
8. Apply the service brake and disengage the park brake. Place the Transmission in (F) Forward at 4th gear.

## ***Section 7- Lubrication and Maintenance***

---

9. Stall the transmission against service brake at full throttle a maximum of 60 seconds. If transmission temperature icon illuminates, go to step 12.
10. Allow engine to run at idle for 30 seconds.
11. Repeat steps 9 and 10 three more times or until the transmission temperature icon illuminates.
12. Place the transmission in (N) Neutral and apply the park brake. Allow the engine to run at idle for 30 seconds.
13. Open engine cover.
14. Verify that top **(2)** of transmission oil cooler **(3)** is warm to determine that the bypass valve **(4)** has closed and oil is circulating through the cooler. If the top of the transmission oil cooler is not warm, repeat steps 6 thru 10.
15. Remove transmission dipstick **(1)** and check oil level. The oil level should be in the HOT zone.
16. Add oil as required.
17. Replace transmission dipstick.
18. Close and secure engine cover.
19. Shut engine off.

## Section 7- Lubrication and Maintenance

### Hydraulic Oil

#### A. Hydraulic Oil Level Check

**10**   
OW0970

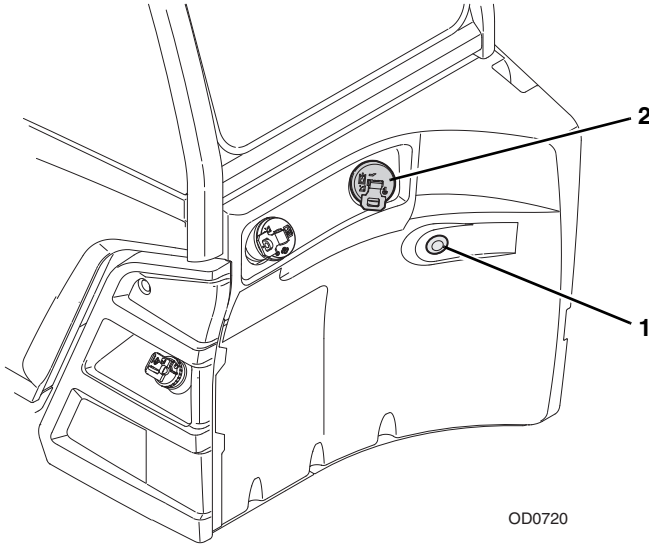

1. Be sure all cylinders are fully retracted, outriggers (if equipped) are fully raised and machine is level.
2. Perform "Shut-Down Procedure" on page 4-5.
3. If hydraulic oil is cold, check fluid level at sight gauge (1). Oil level should be visible in gauge window.
4. Remove fill cap (2). Add fluid to bring oil up to the center of the sight gauge.
5. Replace hydraulic oil fill cap.

**Brake Reservoir Level**

**A. Brake Reservoir Level Check**

**10**   
OW0970

  
OD1380

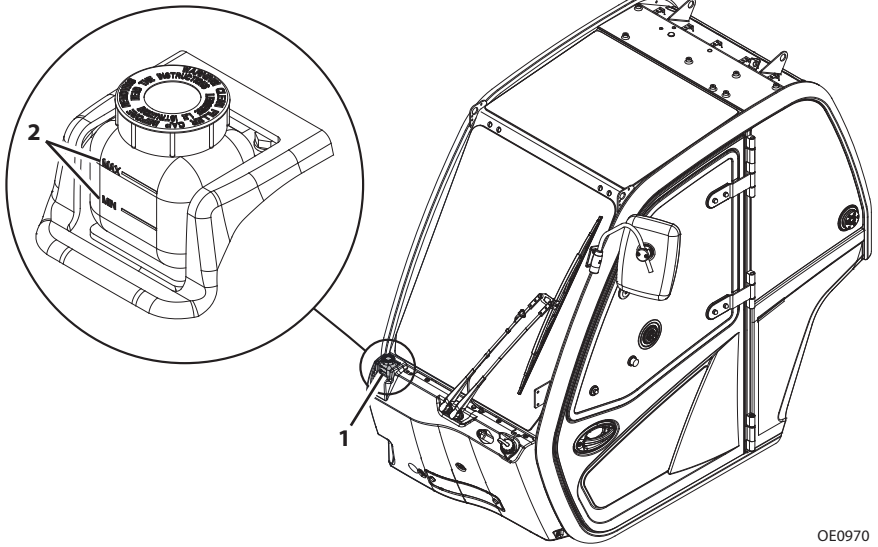

OE0970

1. Perform "Shut-Down Procedure" on page 4-5.
2. Check the brake reservoir level (1). Fluid should be between Max and Min (2) marks on brake reservoir.
3. If fluid is low, remove the product from service. See Service Manual for information.

## Section 7- Lubrication and Maintenance

### Engine Cooling System

#### A. Engine Coolant Level Check

50   
OW0980

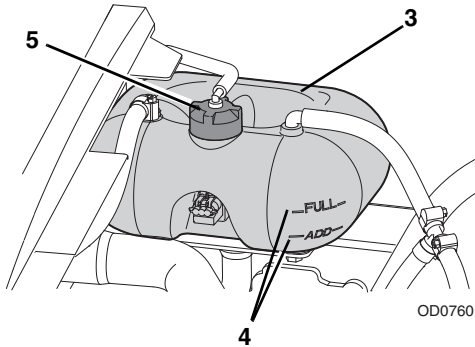

1. Perform "Shut-Down Procedure" on page 4-5.
2. Open engine cover.
3. Check coolant level in surge tank (3). Coolant should be between Full and Add (4) marks on surge tank.
4. If coolant is low, allow fluid to cool.
5. Remove surge tank cap (5) slowly. Add coolant as required.
6. Replace surge tank cap.
7. Close and secure engine cover.

**Note:** When filling coolant, maximum fill rate is 2.5 gallon per minute (9,5 liter per minute).

Windshield Washer System (if equipped)

A. Windshield Washer Fluid Level Check

50   
OW0980

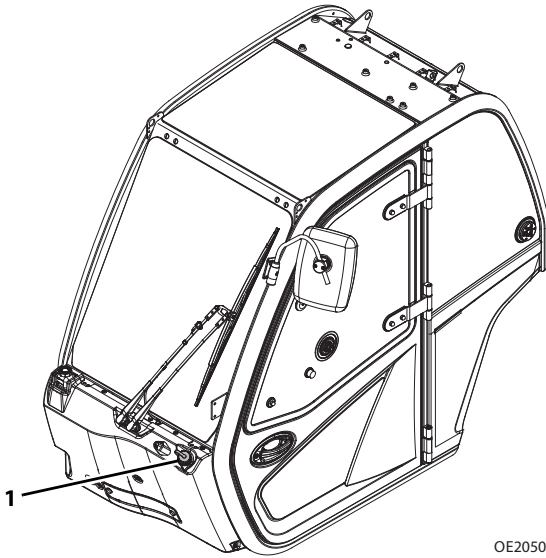

OE2050

1. Perform "Shut-Down Procedure" on page 4-5.
2. Remove reservoir cap (1).
3. Windshield washer fluid should be visible in the reservoir.
4. If washer fluid level is low, add fluid as needed.
5. Replace reservoir cap.

## Section 7- Lubrication and Maintenance

### Cab Air Filters (if equipped)

#### A. Cab Air Filters Check

50   
OW0980

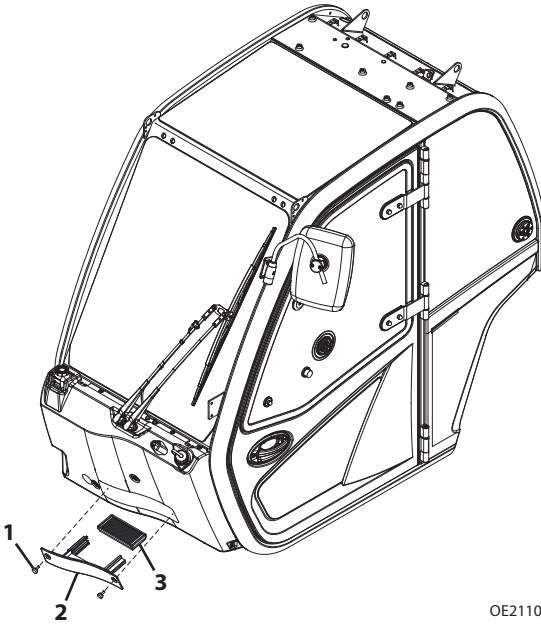

1. Perform "Shut-Down Procedure" on page 4-5.
2. Remove two thumb screws (1) and panel (2) from front of cab.
3. Remove filter (3) and inspect.
4. Replace filter if damaged or has already been cleaned twice.
5. Replace panel on front of cab and secure with thumb screws.



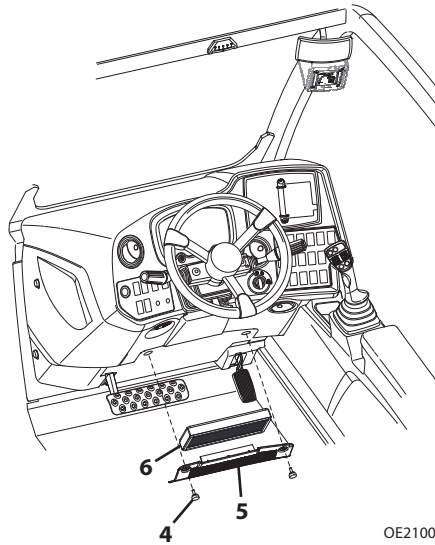

6. Remove two thumb screws (4) and panel (5) from under dash.
7. Remove filter (6) and inspect.
8. Replace filter if damaged or has already been cleaned twice.
9. Replace panel and secure with thumb screws.

**This Page Intentionally Left Blank**

## SECTION 8 - ADDITIONAL CHECKS

### 8.1 GENERAL

If any of the following test results cannot be achieved, the system is not functioning properly and the machine must be removed from service and repaired before continued operation.

### 8.2 REVERSE SENSING SYSTEM (IF EQUIPPED)

#### A. Reverse Sensing System Check



Reverse Sensing System provides audible indication of objects to rear of unit while in reverse gear.

1. Clear all people and/or obstacles behind machine before performing Reverse Sensing System check.
2. Start machine and depress and hold brake. Place machine in reverse gear.
3. Verify alarm sounds upon system start up.

**Note:** Reverse Sensing System detects objects of size more than 36 square inches (232.25 square centimeters) area and is functional when machine is moving in reverse direction.

**Note:** The use of a construction cone or similar object must be used to test the Reverse Sensing System.



## WARNING

**CRUSH HAZARD.** Do not use a person to test the reverse sensing system.

4. Verify operation with no objects in detection zone. No audible alarm.
5. Verify operation when object is in range of approximately 9 to 15 ft (2.7 to 4.5 m). Produces pulsing audible alarm at a frequency of one per second (1 Hz).
6. Verify operation when object is in range of approximately 7 to 9 ft (2.1 to 2.7 m). Produces pulsing audible alarm. Produces pulsing audible alarm at a frequency of two per second (2 Hz).
7. Verify operation when object is range of approximately 5 to 7 ft (1.5 to 2.1 m). Produces pulsing audible alarm at a frequency of four per second (4 Hz).
8. Verify operation when object is under approximately 5 ft (1.5 m) from machine. Produces pulsing audible alarm at a frequency of eight per second (8 Hz).

**This Page Intentionally Left Blank**

## SECTION 9 - SPECIFICATIONS

## 9.1 PRODUCT SPECIFICATIONS

## Fluids

SN ML800150 to Present, SN MLJ00150 to Present, SN ML500150 to Present,  
SN ML700150 to Present

Compartment or System	Type and Classification	Viscosities	Ambient Temperature Range			
			°F		°C	
			Min	Max	Min	Max
Engine Crankcase	CAT DEO ULS API CK-4	SAE 15W-40	14	118	-10	48
		SAE 10W-30	-4	104	-20	40
		SAE 0W-40	-40	118	-40	48
Transmission and Transfer Case	CAT TDTO	SAE 50	50	118	10	48
		SAE 30	32	95	0	35
		SAE 10W	0	95	-20	35
		SAE 5W-30	-22	68	-30	20
		SAE 0W-30	-40	68	-40	20
Axle Differential and Wheel Ends	CAT Gear Oil (GO)*	SAE 80W-90	-4	118	-20	48
	API GL5 with LS Additives	80W-90 LS	-4	118	-20	48
		85W-90 LS	-4	118	-20	48
		75W-90 LS	-40	118	-40	48
Hydraulic System	CAT TDTO CAT Arctic TDTO SYN commercial TO-4	SAE 15W-40	5	118	-15	48
		SAE 10W-30	-4	104	-20	40
		SAE 30	50	118	10	48
		SAE 10W	-4	104	-20	40
		SAE 5W-40	-22	104	-30	40
		SAE 5W-30	-22	104	-30	40
		SAE 0W-30	-40	104	-40	40
		SAE 0W-20	-40	104	-40	40
		CAT TDTO-TMS	-4	118	-20	48
Boom Wear Pad Grease	Extreme Pressure Grease	NLGI Grade 000	-31	118	-35	48
Grease Fittings	Extreme Pressure Grease	NLGI Grade 2 EP or NLGI Grade 3EP with Moly Additive	5	118	-15	48

## Section 9- Specifications

Compartment or System	Type and Classification	Viscosities	Ambient Temperature Range			
			°F		°C	
			Min	Max	Min	Max
Boom Chain Lubricant	Gear Oil	80W-90	-40	118	-40	48
Engine Coolant	CAT Extended Life Coolant (ELC)	50/50 Mix	Standard			
		60/40 Mix	Cold Weather			
Fuel	EN590 ASTM D975 Grade 1-D ASTM D975 Grade 2-D (Maximum B5 Diodiesel)	Ultra Low Sulfur (S ≤ 15 mg/kg)				
Diesel Exhaust Fluid	ISO22241-1	32.5%Urea				
Brake Fluid	Mobil ATF-D/M		-40	118	-40	48
Air Conditioning	Refrigerant R-134-a	Tetrafluoroethane				

\*Friction Modifier (197-0017) required for axle differentials. Must be pre-mixed with axle fluid.

## Section 9- Specifications

**SN MLG00150 to Present, SN MLD00150 to Present, SN MNT00150 to Present, SN MYW00150 to Present**

Compartment or System	Type and Classification	Viscosities	Ambient Temperature Range			
			°F		°C	
			Min	Max	Min	Max
Engine Crankcase	CAT DEO API CI-4	SAE 15W-40	14	118	-10	48
		SAE 10W-30	-4	104	-20	40
		SAE 0W-40	-40	118	-40	48
Transmission and Transfer Case	CAT TDTO	SAE 50	50	118	10	48
		SAE 30	32	95	0	35
		SAE 10W	0	95	-20	35
		SAE 5W-30	-22	68	-30	20
		SAE 0W-30	-40	68	-40	20
Axle Differential and Wheel Ends	CAT Gear Oil (GO)*	SAE 80W-90	-4	118	-20	48
	API GL5 with LS Additives	80W-90 LS	-4	118	-20	48
		85W-90 LS	-4	118	-20	48
		75W-90 LS	-40	118	-40	48
Hydraulic System	CAT TDTO CAT Arctic TDTO SYN commercial TO-4	SAE 15W-40	5	118	-15	48
		SAE 10W-30	-4	104	-20	40
		SAE 30	50	118	10	48
		SAE 10W	-4	104	-20	40
		SAE 5W-40	-22	104	-30	40
		SAE 5W-30	-22	104	-30	40
		SAE 0W-30	-40	104	-40	40
		SAE 0W-20	-40	104	-40	40
		CAT TDTO-TMS	-4	118	-20	48
Boom Wear Pad Grease	Extreme Pressure Grease	NLGI Grade 000	-31	118	-35	48
Grease Fittings	Extreme Pressure Grease	NLGI Grade 2 EP or NLGI Grade 3 EP with Moly Additive	5	118	-15	48
Boom Chain Lubricant	Gear Oil	80W-90	-40	118	-40	48
Engine Coolant	CAT Extended Life Coolant (ELC)	50/50 Mix	Standard			
		60/40 Mix	Cold Weather			

## Section 9- Specifications

Compartment or System	Type and Classification	Viscosities	Ambient Temperature Range			
			°F		°C	
			Min	Max	Min	Max
Fuel	EN590 ASTM D975 Grade 1-D ASTM D975 Grade 2-D (Maximum B5 Diodiesel)	Low Sulfur (S ≤ 500 mg/kg)				
Brake Fluid	Mobil ATF-D/M	-40	118	-40	48	
Air Conditioning	Refrigerant R-134-a	Tetrafluoroethane				

*\*Friction Modifier (197-0017) required for axle differentials. Must be pre-mixed with axle fluid.*



---

**Capacities**

---

**Engine Crankcase Oil**

Capacity with Filter Change

TL642D, TL943D .....	8.3 qt (7,9 L)
TL1055D, TL1255D.....	8.1 qt (7,7 L)

**Fuel Tank**

Capacity ..... 38.3 gal (145 L)

**Diesel Exhaust Fluid Tank, (SN ML800150 to Present, SN MLJ00150 to Present, SN ML500150 to Present, SN ML700150 to Present)**

Capacity .....5.7 gal (21,5 L)

**Cooling System**

System Capacity.....6.0 gal (22,6 L)

**Hydraulic System**

System Capacity

TL642D	
No Outriggers.....	40.2 gal (152 L)
With Outriggers.....	41.7 gal (158 L)
TL943D	
No Outriggers.....	46.5 gal (176 L)
With Outriggers.....	48.6 gal (184 L)
TL1055D .....	48.6 gal (184 L)
TL1255D .....	49.9 gal (189 L)

Reservoir Capacity to Full Mark.....23.8 gal (90 L)

**Transmission System**

Capacity with Filter Change..... 17 qt (16,1L)

**Transfer Case**

Capacity ..... 3.2 qt (3,0 L)

## Section 9- Specifications

---

### Axles

#### Differential Housing Capacity

##### TL642D

##### Front Axle

if utilizing fluid with LS Additives .....	7.6 qt (7,2 L)
if utilizing fluid without LS Additives* .....	7.2 qt (6,8 L)

##### Rear Axle

if utilizing fluid with LS Additives .....	7.1 qt (6,7 L)
if utilizing fluid without LS Additives* .....	6.8 qt (6,4 L)

##### TL943D

##### Front Axle

if utilizing fluid with LS Additives .....	13.2 qt (12,5 L)
if utilizing fluid without LS Additives* .....	12.6 qt (11,9 L)

##### Rear Axle

if utilizing fluid with LS Additives .....	12.8 qt (12,1 L)
if utilizing fluid without LS Additives* .....	12.2 qt (11,5 L)

##### TL1055D, TL1255D

##### Front Axle

if utilizing fluid with LS Additives .....	15.0 qt (14,2 L)
if utilizing fluid without LS Additives* .....	14.3 qt (13,5 L)

##### Rear Axle

if utilizing fluid with LS Additives .....	14.0 qt (13,3 L)
if utilizing fluid without LS Additives* .....	13.3 qt (12,6 L)

*\*If axle fluid does not contain LS Additives, Friction Modifier must be added. Pre-mix before placing in axle differential. Not pre-mixing fluids can lead to excessive brake noise.*

#### Friction Modifier (if needed)

TL642D .....	11.5 oz (340 mL)
TL943D .....	24.0 oz (710 mL)
TL1055D, TL1255D	
Front Axle .....	24.0 oz (710 mL)
Rear Axle .....	22.4 oz (662 mL)

#### Wheel End Capacity

##### TL642D

Front .....	1.2 qt (1,1 L)
Rear .....	1.4 qt (1,3 L)

##### TL943D ..... 1.7 qt (1,6 L) |

##### TL1055D, TL1255D

Front .....	1.8 qt (1,7 L)
Rear .....	1.5 qt (1,4 L)

#### Air Conditioning System (if equipped)

System Capacity .....	2.6 lb (1,2 kg)
-----------------------	-----------------

#### Brake Fluid

Capacity .....	1.1 qt (1,0 L)
----------------	----------------

**Tires**

**TL642D**

370/75-28, 14 Ply	
Pneumatic.....	76 psi (5,25 bar)
Pneumatic, Non Marking.....	73 psi (5,0 bar)
Foam .....	Approx 464 lb (210 kg)
13.00–24 16PR	
Pneumatic.....	80 psi (5,5 bar)
13.00–24 12PR	
Foam .....	Approx 542 lb (246 kg)

**TL943D**

370/75-28, 14 Ply	
Pneumatic.....	76 psi (5,25 bar)
Pneumatic, Non Marking.....	73 psi (5,0 bar)
Foam .....	Approx 464 lb (210 kg)
14.00–24 16PR	
Pneumatic.....	80 psi (5,5 bar)
14.00–24 12PR	
Foam .....	Approx 720 lb (327 kg)

**TL1055D**

400/75-28, 16 Ply	
Pneumatic.....	76 psi (5,25 bar)
Foam .....	Approx 570 lb (259 kg)
14.00–24 16PR	
Pneumatic.....	80 psi (5,5 bar)
14.00–24 12PR	
Foam .....	Approx 720 lb (327 kg)

**TL1255D**

400/75-28, 16 Ply	
Pneumatic.....	76 psi (5,25 bar)
Foam .....	Approx 570 lb (259 kg)
17.50–25 16PR	
Pneumatic.....	69 psi (4,75 bar)
17.50–25 12PR	
Foam .....	Approx 785 lb (356 kg)

**Wheel Lug Nut**

Torque.....	375 ±25 lb-ft (508 ±34 Nm)
-------------	----------------------------

## Section 9- Specifications

---

### Performance

---

#### Maximum Lift Capacity

TL642D .....	6,500 lb (2994 kg)
TL943D .....	9,000 lb (4082 kg)
TL1055D .....	10,000 lb (4536 kg)
TL1255D .....	12,000 lb (5443 kg)

#### Maximum Lift Height

TL642D .....	42 ft (12,8 m)
TL943D .....	43 ft (13,1 m)
TL1055D, TL1255D .....	55 ft (16,8 m)

#### Capacity at Maximum Height

TL642D	
No Outriggers .....	6,000 lb (2722 kg)
With Outriggers	
Outriggers Engaged.....	6,500 lb (2994 kg)
Outriggers Not Engaged .....	6,000 lb (2722 kg)
TL943D .....	7,000 lb (3175 kg)
TL1055D	
Outriggers Engaged .....	5,000 lb (2268 kg)
Outriggers Not Engaged.....	0 lb (0 kg)
TL1255D	
Outriggers Engaged .....	5,000 lb (2268 kg)
Outriggers Not Engaged.....	0 lb (0 kg)

#### Maximum Forward Reach

TL642D .....	29 ft (8,8 m)
TL943D .....	30.5 ft (9,3 m)
TL1055D, TL1255D .....	42 ft (12,8 m)

#### Capacity at Maximum Forward Reach

TL642D	
No Outriggers .....	700 lb (318 kg)
With Outriggers	
Outriggers Engaged.....	1,700 lb (771 kg)
Outriggers Not Engaged .....	600 lb (272 kg)
TL943D	
No Outriggers .....	1,200 lb (544 kg)
With Outriggers	
Outriggers Engaged.....	2,700 lb (1225 kg)
Outriggers Not Engaged .....	1,100 lb (499 kg)
TL1055D	
Outriggers Engaged .....	2,500 lb (1134 kg)
Outriggers Not Engaged.....	0 lb (0 kg)
TL1255D	
Outriggers Engaged .....	3,500 lb (1588 kg)
Outriggers Not Engaged.....	0 lb (0 kg)

## Section 9- Specifications

### Reach at Maximum Height

TL642D.....	62.3 in (1582 mm)
TL943D.....	72.4 in (1840 mm)
TL1055D, TL1255D.....	99.5 in (2527 mm)

### Auxiliary Hydraulic Circuit Max Flow

TL642D.....	18 gpm (68 lpm)
TL943D, TL1055D, TL1255D .....	25 gpm (94,6 lpm)

### Maximum Travel Speed (see note)

TL642D.....	21 mph (33.8 kph)
TL943D.....	19 mph (30.5 kph)
TL1055D, TL1255D.....	20 mph (32 kph)

### Hitch Capacity (no load on attachment)

TL642D.....	6,500 lb (2994 kg)
TL943D.....	9,000 lb (4082 kg)
TL1055D .....	10,000 lb (4536 kg)
TL1255D .....	12,000 lb (5443 kg)

Frame Leveling ..... 10 degrees

### Maximum Travel Grade (boom in travel position)

Gradeability .....	24 degrees (45%)
Side Slope.....	5 degrees (8.75%)

**Note:** Refer to machine specific documents and/or plates for local governmental requirements and/or restrictions.

## Section 9- Specifications

---

### Dimensions

---

**Note:** Values will vary depending on machine configuration.

#### Maximum Overall Height

TL642D .....	96 in (2430 mm)
TL943D .....	98 in (2498 mm)
TL1055D, TL1255D .....	100 in (2540 mm)

#### Maximum Overall Width

TL642D, TL943D	
No Outriggers .....	97 in (2470 mm)
With Outriggers	
Outriggers Engaged.....	134 in (3404 mm)
Outriggers Not Engaged .....	97 in (2470 mm)
TL1055D, TL1255D	
Outriggers Engaged .....	126.25 in (3207 mm)
Outriggers Not Engaged.....	100.75 in (2559 mm)

Maximum Track Width ..... 84.25 in (2140 mm)

#### Wheelbase

TL642D, TL943D .....	135 in (3430 mm)
TL1055D, TL1255D .....	137.5 in (3493 mm)

#### Length at Front Wheels

TL642D, TL943D .....	192 in (4865 mm)
TL1055D, TL1255D .....	200 in (5086 mm)

#### Overall Length (no forks)

TL642D .....	235 in (5980 mm)
TL943D .....	245 in (6233 mm)
TL1055D, TL1255D .....	251 in (6380 mm)

#### Ground Clearance

TL642D, TL943D .....	17 in (432 mm)
TL1055D, TL1255D .....	18 in (457 mm)

#### Turning Radius - Over Tires

TL642D .....	142 in (3598 mm)
TL943D .....	143 in (3640 mm)
TL1055D, TL1255D .....	168 in (4267 mm)

#### Turning Radius - Curb to Curb

TL642D .....	137 in (3468 mm)
TL943D .....	139 in (3532 mm)
TL1055D, TL1255D .....	168 in (4267 mm)

**Maximum Operating Weight (no attachment)**

TL642D	
No Outriggers.....	23,907 lb (10 844 kg)
With Outriggers .....	25,097 lb (11 384 kg)
TL943D	
No Outriggers.....	28,396 lb (12 880 kg)
With Outriggers .....	29,498 lb (13 380 kg)
TL1055D .....	33,997 lb (15 421 kg)
TL1255D .....	36,954 lb (16 762 kg)

**Distribution of Maximum Operating Weight  
(no attachment, boom level and fully retracted)**

**Front Axle**

TL642D	
No Outriggers.....	11,127 lb (5047 kg)
With Outriggers .....	13,014 lb (5903 kg)
TL943D	
No Outriggers.....	13,181 lb (5979 kg)
With Outriggers .....	14,672 lb (6655 kg)
TL1055D .....	16,845 lb (7641 kg)
TL1255D .....	17,394 lb (7890 kg)

**Rear Axle**

TL642D	
No Outriggers.....	12,780 lb (5797 kg)
With Outriggers .....	12,084 lb (5481 kg)
TL943D	
No Outriggers.....	15,214 lb (6901 kg)
With Outriggers .....	14,826 lb (6725 kg)
TL1055D .....	17,152 lb (7780 kg)
TL1255D .....	19,015 lb (8625 kg)

## Section 9- Specifications

---

### Maximum Ground Bearing Pressure

#### TL642D

Outriggers (if equipped) ..... 104 lb/in<sup>2</sup> (7,3 kg/cm<sup>2</sup>)

#### Tires

##### 370/75-28, 14 Ply

Pneumatic ..... 113 lb/in<sup>2</sup> (7,9 kg/cm<sup>2</sup>)

Foam ..... 130 lb/in<sup>2</sup> (9,1 kg/cm<sup>2</sup>)

##### 13.00-24 16PR

Pneumatic ..... 143 lb/in<sup>2</sup> (10,1 kg/cm<sup>2</sup>)

##### 13.00-24 12PR

Foam ..... 159 lb/in<sup>2</sup> (11,2 kg/cm<sup>2</sup>)

315/95-28/8.50 Solid ..... 202 lb/in<sup>2</sup> (14,2 kg/cm<sup>2</sup>)

13.00-24 Solid ..... 213 lb/in<sup>2</sup> (15,0 kg/cm<sup>2</sup>)

#### TL943D

Outriggers (if equipped) ..... 119 lb/in<sup>2</sup> (8,4 kg/cm<sup>2</sup>)

#### Tires

##### 370/75-28, 14 Ply

Pneumatic ..... 115 lb/in<sup>2</sup> (8,1 kg/cm<sup>2</sup>)

Foam ..... 132 lb/in<sup>2</sup> (9,3 kg/cm<sup>2</sup>)

##### 14.00-24 16PR

Pneumatic ..... 137 lb/in<sup>2</sup> (9,6 kg/cm<sup>2</sup>)

##### 14.00-24 12PR

Foam ..... 163 lb/in<sup>2</sup> (11,5 kg/cm<sup>2</sup>)

315/95-28/8.50 Solid ..... 211 lb/in<sup>2</sup> (14,8 kg/cm<sup>2</sup>)

13.00-24 Solid ..... 223 lb/in<sup>2</sup> (15,7 kg/cm<sup>2</sup>)

#### TL1055D

Outriggers ..... 137 lb/in<sup>2</sup> (9,6 kg/cm<sup>2</sup>)

#### Tires

##### 400/75-28, 16 Ply

Pneumatic ..... 111 lb/in<sup>2</sup> (7,8 kg/cm<sup>2</sup>)

Foam ..... 127 lb/in<sup>2</sup> (9,0 kg/cm<sup>2</sup>)

##### 14.00-24 16PR

Pneumatic ..... 140 lb/in<sup>2</sup> (9,8 kg/cm<sup>2</sup>)

##### 14.00-24 12PR

Foam ..... 165 lb/in<sup>2</sup> (11,6 kg/cm<sup>2</sup>)

360/85-28/10.00 Solid ..... 217 lb/in<sup>2</sup> (15,3 kg/cm<sup>2</sup>)

14.00-24 Solid ..... 240 lb/in<sup>2</sup> (16,9 kg/cm<sup>2</sup>)

#### TL1255D

Outriggers ..... 150 lb/in<sup>2</sup> (10,6 kg/cm<sup>2</sup>)

##### 400/75-28, 16 Ply

Pneumatic ..... 113 lb/in<sup>2</sup> (7,9 kg/cm<sup>2</sup>)

Foam ..... 129 lb/in<sup>2</sup> (9,1 kg/cm<sup>2</sup>)

##### 17.50-25 16PR

Pneumatic ..... 124 lb/in<sup>2</sup> (8,7 kg/cm<sup>2</sup>)

##### 17.50-25 12PR

Foam ..... 120 lb/in<sup>2</sup> (8,4 kg/cm<sup>2</sup>)

360/85-28/10.00 Solid ..... 232 lb/in<sup>2</sup> (16,4 kg/cm<sup>2</sup>)

14.00-24 Solid ..... 250 lb/in<sup>2</sup> (17,6 kg/cm<sup>2</sup>)



<b>A</b>	<b>D</b>
Accessory Control Lever..... 3-16	DEF Level ..... 7-20
Additional Checks ..... 8-1	DEF Tank ..... 9-5
Adjusting/Moving Forks ..... 5-13	Dimensions ..... 9-10
Air Cleaner..... 7-22	Disengaging a Load..... 4-8
Air Conditioning System..... 9-6	Disengaging a Suspended Load ..... 4-11
Approved Attachments..... 5-1	Driving Hazards on Slopes ..... 1-10
Attachment Installation	Dual Fork Positioning Carriage..... 5-22
Hydraulic Coupler ..... 5-11	
Mechanical Coupler..... 5-10	
Attachment Operation ..... 5-14	
Attachments..... 5-1	
JLG Supplied ..... 5-2	
Auxiliary Hydraulic Decompression..... 5-12	
Axles ..... 9-6	
	<b>E</b>
<b>B</b>	Electrical Hazards ..... 1-2
Battery Boosted Starting..... 4-3	Emergency Exit from Enclosed Cab ..... 6-3
Boom Indicator	Emergency Lowering of Boom ..... 6-2
Angle..... 3-24	Emergency Procedures ..... 6-1
Extension ..... 3-24	Engine
Boom Mounted Lifting Lug..... 5-50	Extreme Cold Weather Starting ..... 4-2
Boom Ride Control..... 3-10	Normal Operation ..... 4-4
Brake Fluid..... 9-6	Starting ..... 4-1
Brake Reservoir Level ..... 7-29	Engine Crankcase Oil..... 9-5
Bucket ..... 5-28	Engine Oil Level ..... 7-21
	Exit ..... 6-3
<b>C</b>	
Cab Air Filters ..... 7-32	<b>F</b>
Capacity ..... 5-4	Fall Hazard ..... 1-13
Capacity Chart	Fluids..... 9-1
Example ..... 5-7	Capacities..... 9-5
Sample ..... 5-6	Fork Extension ..... 5-26
Capacity Indicator Locations ..... 5-5	Fork Mounted Hook ..... 5-38
Carriage w/Forks..... 5-15	Frame Level ..... 3-3
Chemical Hazards ..... 1-14	Fuel Level ..... 7-18
Controls..... 3-2	Fuel Tank ..... 9-5
Coolant Level ..... 7-30	Fuel/Water Separator..... 7-19
Cooling System ..... 9-5	
Coupler Mounted Hook ..... 5-36	<b>G</b>
	General Maintenance..... 7-2
	Grapple Bucket..... 5-32
	<b>H</b>
	Hazard Classification System ..... 1-1
	Hydraulic Oil Level ..... 7-28
	Hydraulic System..... 9-5

# Index

---

**I**  
Ignition.....3-12  
Instrument Panel..... 3-4

**J**  
Joystick.....3-18

**L**  
Leveling Procedure..... 4-7, 4-10  
Lifting Personnel ..... 1-9  
Load Falling Hazard..... 1-8  
Lubrication and Maintenance ..... 7-1  
Lubrication Schedule  
    Every 1000 Hours .....7-12  
    Every 250 Hours.....7-10  
    Every 50 Hours ..... 7-8

**M**  
Maintenance Schedule  
    Every 10 Hours ..... 7-3  
    Every 1000 Hours .....7-6  
    Every 1500 Hours ..... 7-6  
    Every 2000 Hours ..... 7-6  
    Every 250 Hours..... 7-4  
    Every 50 Hours ..... 7-4  
    Every 500 Hours..... 7-5  
    Every 750 Hours..... 7-5  
    First 250 Hours ..... 7-4  
    First 50 Hours..... 7-3  
    First 500 Hours ..... 7-5

Material Handling Arm.....5-44  
Multipurpose Bucket.....5-30

**O**  
Operating with a Non-Suspended  
Load ..... 4-6  
Operating with a Suspended Load ..... 4-9  
Operational Check .....2-17  
Operator Cab .....2-18  
Operator Maintenance Instructions .....7-14  
Operator Seat .....3-22  
    Adjustments .....3-22  
Outrigger Levers.....3-17

**P**  
Park Brake .....3-13  
Parking Procedure ..... 3-13  
Performance ..... 9-8  
Personnel Work Platform—  
Fork Mounted.....5-46  
Picking Up a Load ..... 4-6  
Picking Up a Suspended Load..... 4-9  
Pinch Points and Crush Hazards ..... 1-11  
Pipe Grapple .....5-24  
Placing a Load ..... 4-8  
Placing a Suspended Load.....4-11  
Pre-Operation Check and Inspection .... 2-2

**R**  
Rear Axle Stabilization (RAS).....3-26  
Reverse Sensing System.....3-25

**S**  
Safety Practices ..... 1-1  
Safety Signal Words..... 1-1  
Seat Belt.....3-23  
Shut-Down Procedure..... 4-5  
Side Shift Carriage.....5-16  
Side Tilt Carriage .....5-18  
Specifications ..... 9-1  
Steering Alignment Mode  
    Manual.....3-21  
Sweeper .....5-48  
Swing Carriage.....5-20

**T**

Tip Over Hazard.....	1-4
Tires .....	7-24, 9-7
Air Pressure.....	7-24
Damage .....	7-24
Replacement.....	7-24
Towing.....	6-1
Transmission Control	
Direction of Travel.....	3-14
Gear Selection .....	3-15
Transmission Declutch .....	3-19
Transmission Oil Level .....	7-26
Transmission System.....	9-5
Transport	
Lifting.....	4-13
Tie Down .....	4-12
Transporting a Load .....	4-7
Transporting a Suspended Load.....	4-10
Trash Hopper—Fork Mounted .....	5-34
Travel Hazard .....	1-7
Truss Boom .....	5-40
Truss Boom, Adjustable—	
Fork Mounted .....	5-42

**W**





Warm-Up Check.....	2-17
Wheel Installation.....	7-25
Wheel Lug Nut.....	9-7
Wheel Replacement .....	7-24
Windshield Washer Fluid Level .....	7-31





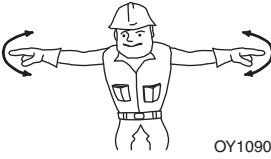
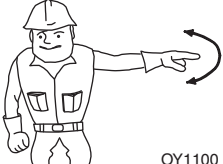

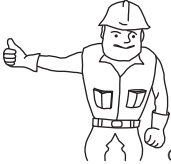
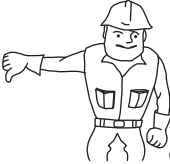
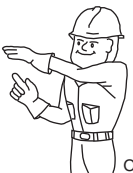
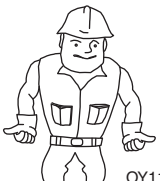
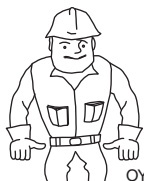
# Hand Signals

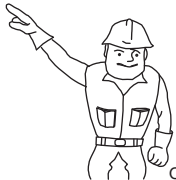
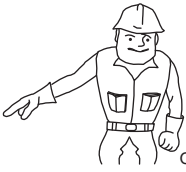
 <p>OY1090</p> <p>EMERGENCY STOP - With both arms extended laterally, hands open downward, move arms back and forth.</p>	 <p>OY1100</p> <p>STOP - With either arm extended laterally, hand open downward, move arm back and forth.</p>	 <p>OY1110</p> <p>STOP ENGINE - Draw thumb or forefinger across throat.</p>
 <p>OY1120</p> <p>RAISE BOOM - With either arm extended horizontally, fingers closed, point thumb upward.</p>	 <p>OY1130</p> <p>LOWER BOOM - With either arm extended horizontally, fingers closed, point thumb downward.</p>	 <p>OY1140</p> <p>MOVE SLOWLY - Place one hand motionless in front of hand giving motion signal. (Raise load slowly shown)</p>
 <p>OY1150</p> <p>EXTEND BOOM - With both hands clenched, point thumbs outward.</p>	 <p>OY1160</p> <p>RETRACT BOOM - With both hands clenched, point thumbs inward.</p>	 <p>OY1170</p> <p>THIS FAR TO GO - With hands raised and open inward, move hands laterally, indicating distance to go.</p>
 <p>OY1180</p> <p>TILT FORKS UP - With one arm held at side, extend other arm upward at about 45 degrees.</p>	 <p>OY1190</p> <p>TILT FORKS DOWN - With one arm held at side, extend other arm downward at about 45 degrees.</p>	

**Special Signals** - When signals for auxiliary equipment functions or conditions not covered are required, they shall be agreed upon in advance by the operator and signalman.

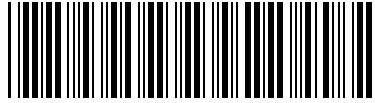

31211035

**CATERPILLAR®**