

Manitowoc 777

Operator Manual





WARNING



California Proposition 65

Breathing diesel engine exhaust exposes you to chemicals known to the State of California to cause cancer and birth defects or other reproductive harm.

Always start and operate the engine in a well-ventilated area.

If in an enclosed area, vent the exhaust to the outside.

Do not modify or tamper with the exhaust system.

Do not idle the engine except as necessary.

For more information, go to www.P65warnings.ca.gov/diesel

Batteries, battery posts, terminals, and related accessories can expose you to chemicals, including lead and lead compounds, which are known to the State of California to cause cancer and birth defects or other reproductive harm. Wash hands after handling. For more information, go to www.P65warnings.ca.gov



California Spark Arrestor

Operation of this equipment may create sparks that can start fires around dry vegetation. A spark arrestor may be required. The owner/ operator should contact local fire agencies for laws or regulations relating to fire prevention requirements.



OPERATOR MANUAL

This manual has been prepared for and is considered part of -

777

Model Number

7771Ref

Serial Number

This Manual is divided into the following sections:

SECTION 1	INTRODUCTION
SECTION 2	SAFETY INFORMATION
SECTION 3	OPERATING CONTROLS AND PROCEDURES
SECTION 4	SET-UP AND INSTALLATION
SECTION 5	LUBRICATION
SECTION 6	MAINTENANCE CHECKLIST

NOTICE

The serial number of the crane is the only method your Manitowoc dealer or Manitowoc Product Support has of providing you with correct parts and service information.

The serial number is located on a crane identification plate attached to the operator's cab. Refer to the Nameplate and Decal Assembly Drawing in Section 2 of this manual for the exact location of the crane identification plate.

Always furnish serial number of crane and its attachments when ordering parts or discussing service problems with your Manitowoc dealer or Manitowoc Product Support.



WARNING

To prevent death or serious injury:

- Avoid unsafe operation and maintenance.
Crane and attachments must be operated and maintained by trained and experienced personnel. Manitowoc is not responsible for qualifying these personnel.
- Do not operate or work on crane or attachments without first reading and understanding instructions contained in Operator Information Manual and Service Manual supplied with crane and applicable attachments.
- Store Operator Information Manual and Service Manual in operator's cab.
If Operator Information Manual or Service Manual is missing from cab, contact your Manitowoc dealer for a new one.

THIS PAGE INTENTIONALLY LEFT BLANK

171163

See end of this manual for Alphabetical Index

SECTION 1	Introduction
Crane Data	1-1
Crane/Attachment Identification	1-1
Change of Ownership Registration	1-1
Crane Orientation	1-1
Manitowoc Dealer	1-1
Identification and Location of Components	1-2
Outline Dimensions	1-4
Crane Weights	1-5
English and Metric Conversions	1-8
Direct Conversion	1-8
Inverse Conversion	1-8
SECTION 2	Safety Information
Continuous Innovation	2-1
Nameplates and Decals	2-1
Safety Messages	2-1
General	2-1
Safety Alert Symbol	2-1
Signal Words	2-1
Symbol Identification	2-1
Safety and Information Signs	2-3
Maintaining Signs	2-3
Ordering Signs	2-3
Crane Access Points	2-4
General	2-4
Getting On or Off Crane	2-4
Personal Fall-Protection	2-6
Operator Manual/Capacity Chart Storage	2-6
General	2-6
Storing Manuals	2-6
Safe Operating Practices	2-7
General	2-7
Work Area Control	2-7
Read Operator Manual	2-7
Operator Qualifications	2-7
Operator Conduct	2-8
Handling Load	2-9
Signals	2-11
Safety Devices	2-12
Operational Aids	2-12
Category 1 Operational Aids	2-12
Category 2 Operational Aids	2-13
Assembling, Disassembling, or Operating Crane Near Electric Power and Transmission Lines	2-14
Electrocution Hazard	2-14
Set-Up and Operation	2-14
Electrical Contact	2-15
Refueling	2-15
Fire Extinguishers	2-15
Accidents	2-15
Safe Maintenance	2-16
Maintenance Instructions	2-16
Safe Maintenance Practices	2-16
Environmental Protection	2-17
Boom Disassembly Safety	2-19

General	2-19
Location	2-19
Pin Removal	2-19
Disassembly Precaution	2-19
Special Application/Service	2-20
Personnel Handling Policy	2-20
Pedestal/Barge Mounted Cranes	2-21
Pedestal Mounted Crane	2-22
Barge Mounted Crane	2-22
Capacity Charts for Barge Mounted Crane	2-23
Shock Loading Caused by Barge Dynamics	2-24
Operation on Barge	2-24
Barge Mount Definitions	2-24
Inspection of Barge-Mounted Crane	2-24
Transporting Crane on Barge	2-25
Pile Driving and Extracting	2-25
Introduction	2-25
Operation of Pile Driving and Extracting Equipment	2-25
Crane Equipment	2-25
Crane Inspection	2-25
Electrocution Hazard Devices	2-26
Multiple Load Line Operation	2-26
Multiple Crane Lifts	2-27

SECTION 3. Operating Controls And Procedures

Standard Hand Signals for Controlling Crane Operations	3-2
Symbol Identification	3-4
Front Window Operation	3-8
Closing Window	3-8
Opening Window for Ventilation	3-8
Opening Window for Emergency Exit	3-8
Operating Controls	3-8
Controls Identification and Function	3-11
A – Power Controls	3-11
B – Engine Controls	3-11
C – Accessory Controls	3-12
D – Indicators	3-13
E – Gauges	3-14
F – Special Controls/Indicators	3-17
G – Boom Hoist Controls	3-18
H – Load Drum Controls	3-19
J – Swing Controls	3-21
K – Travel Controls	3-22
Remote Controls	3-22
Limit Devices	3-23
Counterweight Max Up Limit	3-23
Boom Maximum Up Limit	3-23
Boom Maximum Down Limit (if equipped)	3-23
Block Up Limit	3-23
Luffing Jib Max Up Limit	3-23
Luffing Jib Max Up 1 Limit	3-24
Luffing Jib Max Up 2 Limit	3-24
Luffing Jib Max Down Limit	3-24
Luffing Jib Max Down 1 Limit	3-24
Luffing Jib Max Down 2 Limit	3-24
Maximum Bail Limit	3-24

Minimum Bail Limit	3-25
Load Moment Limit	3-25
Seat Controls	3-26
Preparing Crane For Operation	3-27
Operation	3-27
Engine Start-up	3-27
Engine Diagnostics	3-29
Boom Hoist Operation	3-30
Boom Hoist Speed Adjustment	3-30
Luffing Hoist Operation	3-31
Swing Operation	3-32
Swing Speed/Torque Adjustment	3-32
Load Drum Operation	3-33
Travel Operation	3-35
Stopping Engine/Leaving Crane Unattended	3-37
Fuses	3-38
Fuse Location	3-38
Fuse Identification	3-38
Voltmeter Operation	3-39
Disabling and Enabling Free Fall	3-40
Disabling Free Fall	3-40
Enabling Free Fall	3-40
Remote Controls	3-43
Controls Identification and Operation	3-44
Programmable Controller Calibration Procedures	3-45
General	3-45
Controls Calibration	3-45
Pressure Sender Calibration	3-45
Digital Display Readings	3-45
Operating Conditions	3-46
Operating Limits	3-46
System Faults	3-46
Selecting Display Language	3-46
Diagnostic Display	3-50
Drum 1, 2, and 8	3-50
BHST (Boom Hoist)	3-51
Swing	3-51
Track	3-51
A1 (Handles)	3-51
D1 and D2 (Digital Outputs and Inputs)	3-52
Swing Limiter Operation	3-57
Programming Swing Limits	3-57
Adjusting Swing Limit Switch	3-60
Hydraulic System Controls	3-62
Components Function	3-62
Wind Conditions	3-64
Cold Weather Heater Package	3-65
General	3-65
Heaters	3-65
Thermostats	3-65
Turning Heaters On	3-65
Turning Heaters Off	3-65
Preparation for Cold Weather	3-68
Crane Limitations	3-68
Wire Rope	3-68
Cold Weather Starting Aid	3-68
Cooling System	3-68

Battery 3-68
 Engine Oil 3-68
 Fuel Oil 3-68
 Gear Oil 3-68
 Hydraulic Oil 3-69

SECTION 4. Set-up and Installation

Rigging Drawings 4-1
 Optional Attachments 4-1
 General Safety 4-1
 Crane Orientation 4-1
 Self-Erecting Equipment 4-1
 Assembly and Disassembly Notes 4-2
 Assembly and Disassembly Area 4-2
 Accessing Parts 4-2
 Crane Weights 4-2
 Retaining Connecting Pins 4-2
 Cold Weather Mast Operation 4-2
 Lowerworks Lubrication at Assembly 4-2
 Operating Limitations 4-4
 Operating Controls 4-5
 Shipping Crane Components 4-5
 Crane Assembly 4-7
 Pre-Start Checks 4-7
 Remove Crane from Trailer 4-7
 Install Crawlers 4-11
 Install Counterweights 4-12
 Assemble Boom 4-17
 Connect Boom Butt To Boom 4-17
 Pre-raising Checks 4-20
 Crane Disassembly 4-23
 Disconnect Butt From Boom 4-23
 Install Assembly Block 4-25
 Disassemble Boom 4-27
 Remove Counterweights 4-27
 Remove Crawlers 4-31
 Install Crane on Trailer 4-33
 Auxiliary Load Drum Installation 4-33
 Crane Requirements 4-33
 Drum Installation 4-33
 Hydraulic and Electric Connections 4-35
 Wire Rope Installation 4-35
 Butt Removal 4-35
 Boom Ladder Assembly 4-37
 Removal From Boom Butt 4-37
 Installation on Boom Inserts 4-37
 Storage in Boom Butt 4-37
 Boom Rigging Guide 4-38
 Assist Crane Requirements 4-38
 Blocked Crawlers 4-41
 Handling Components 4-41
 Boom Rigging Assembly Drawing 4-41
 Identifying Boom Sections And Pendants 4-41
 Removable Lacings 4-43
 Boom Installation 4-45
 Boom Removal 4-48

Pile Driver Adapter 4-52
 Operating Specifications 4-52
 Jib Rigging Guide 4-53
 Assist Crane Requirements 4-53
 Blocked Crawler/Extended Outriggers 4-55
 Jib Assembly Drawing 4-55
 Identifying Jib Sections and Pendants 4-55
 Installing Jib 4-57
 Removing Jib 4-61
 Wire Rope Installation 4-63
 Wire Rope Storage 4-63
 Removing Wire Rope from Shipping Reel 4-63
 Seizing and Cutting Wire Rope 4-64
 Anchoring Wire Rope to Drum 4-64
 Winding Wire Rope onto Drum 4-65
 Anchoring Wire Rope to Wedge Socket 4-66
 Breaking in Wire Rope 4-68
 Pad Eye Usage for Wire Rope Reeving 4-68
 General 4-68
 Safety 4-68
 Load Line Reeving 4-70
 Reeving Diagrams 4-70
 Wire Rope Specifications 4-70
 Wire Rope Installation 4-70
 Guide Sheave Identification 4-70
 Load Pin Sheaves 4-70
 Universal Anchor Joint 4-70
 Load Blocks 4-70
 Clamshell Reeving 4-76
 General 4-76
 Wire Rope Specifications 4-76
 Wire Rope Installation 4-76
 Load Block Tieback 4-79
 Specifications 4-79
 Universal Anchor Joint 4-80

SECTION 5 Lubrication

Lubrication 5-1

SECTION 6 Maintenance Checklist

Inspection and Maintenance Checklist 6-1
 Fiberglass Maintenance 6-1

THIS PAGE INTENTIONALLY LEFT BLANK

777163

SECTION 1 INTRODUCTION

TABLE OF CONTENTS

Crane Data	1-1
Crane/Attachment Identification	1-1
Change of Ownership Registration	1-1
Crane Orientation	1-1
Manitowoc Dealer	1-1
Identification and Location of Components	1-2
Outline Dimensions	1-4
Crane Weights	1-5
English and Metric Conversions	1-8
Direct Conversion	1-8
Inverse Conversion	1-8

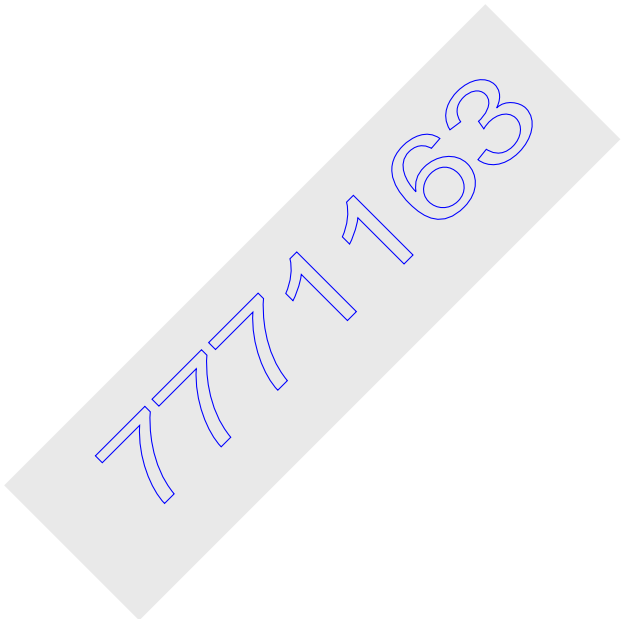

THIS PAGE INTENTIONALLY LEFT BLANK

777163

SECTION 1

INTRODUCTION

CRANE DATA

See the end of this section for crane data specific to your crane:

- Basic Specifications.
- EC Declaration (if applicable).

CRANE/ATTACHMENT IDENTIFICATION

An identification plate (see Figure 1-1) is attached to the outside of the operator's cab and to attachments available for this crane (for example, luffing jib).

The crane or attachment model and serial number are provided on the plates.

For the exact location of the identification plates on your crane, see the Nameplates and Decals Drawing in Section 2 of this manual.

CHANGE OF OWNERSHIP REGISTRATION

If you are the new owner of a Manitowoc crane, please register it with Manitowoc Product Support so we can contact you if the need arises.

1. Go to www.manitowoc.com
2. Go to SUPPORT>SERVICES>CHANGE OF OWNERSHIP.

3. Complete the form.

CRANE ORIENTATION

The terms RIGHT, LEFT, FRONT, REAR used in this manual refer to operator's right, left, front, and rear sides when seated in the operator's cab looking forward.

- The boom is on the front of the rotating bed.
- The carbody and crawler controls are on the front of the carbody.
- The drive shafts and gear boxes are on the rear of the crawlers.

MANITOWOC DEALER

For questions about this manual or the 777 crane, contact your Manitowoc dealer. If you do not know the contact information for your dealer, locate the Manitowoc dealer nearest you, as follows:

1. Go to www.manitowoc.com
2. Click on the red FIND A DEALER button.
3. Follow the on-screen prompts to locate your Manitowoc dealer.

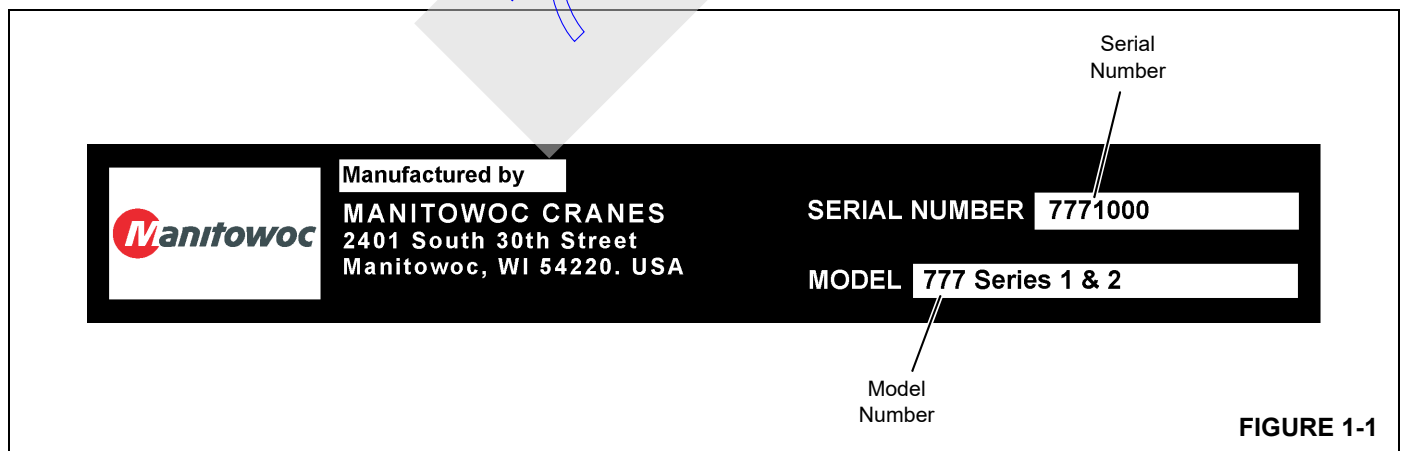
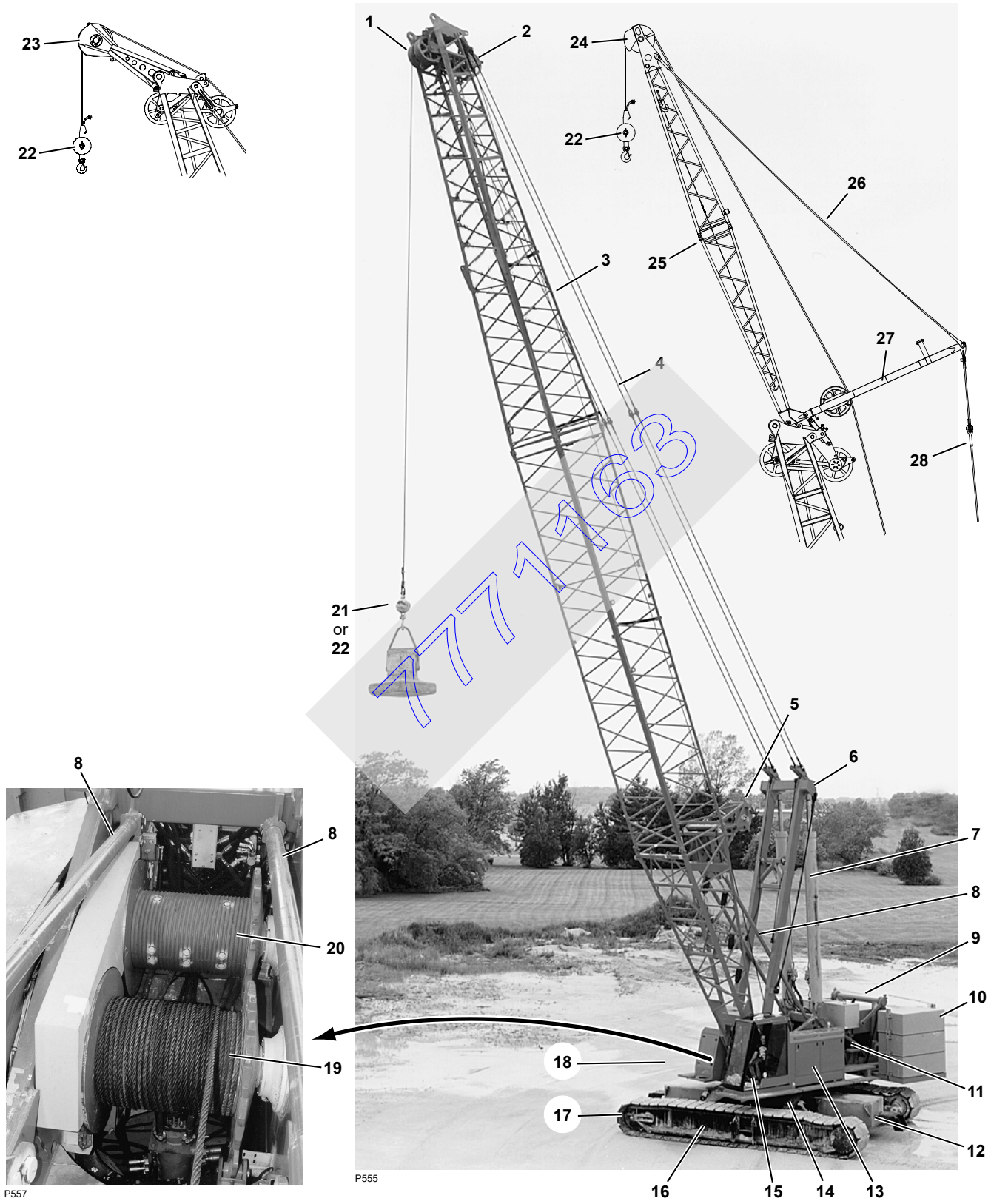
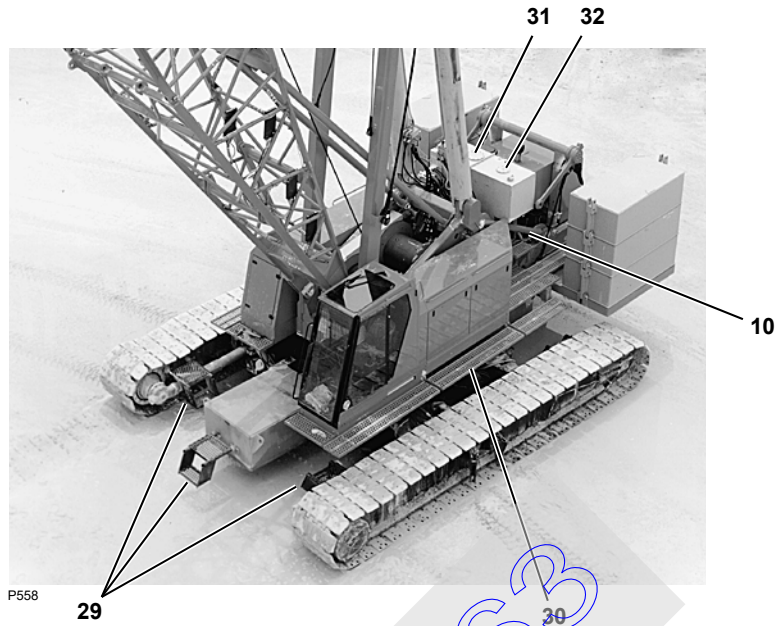

FIGURE 1-1

IDENTIFICATION AND LOCATION OF COMPONENTS





Item	Description	Item	Description
1	Boom Point, Lower	17	Carriage
2	Guide, Wire Rope (boom top)	18	Bed, Rotating
3	Boom, #78	19	Drum, Front
4	Pendant, Boom	20	Drum, Rear
5	Guide, Wire Rope (boom butt)	21	Load Block
6	Mast	22	Hook and Weight Ball
7	Cylinder, Boom Hoist	23	Boom Point, Upper
8	Boom Stop, Telescopic	24	Jib Point
9	Pivot Frame, Counterweight Handling	25	Jib, #138 Fixed
10	Counterweight, Upper	26	Pendant, Jib
11	Engine	27	Strut, Jib
12	Counterweight, Carbody	28	Pendant, Jib Backstay
13	Enclosure, Left Side	29	Steps (both ends carriage)
14	Carbody	30	Catwalk (both sides rotating bed)
15	Cab, Operator's	31	Tank, Hydraulic
16	Crawler	32	Tank, Fuel

OUTLINE DIMENSIONS

179050

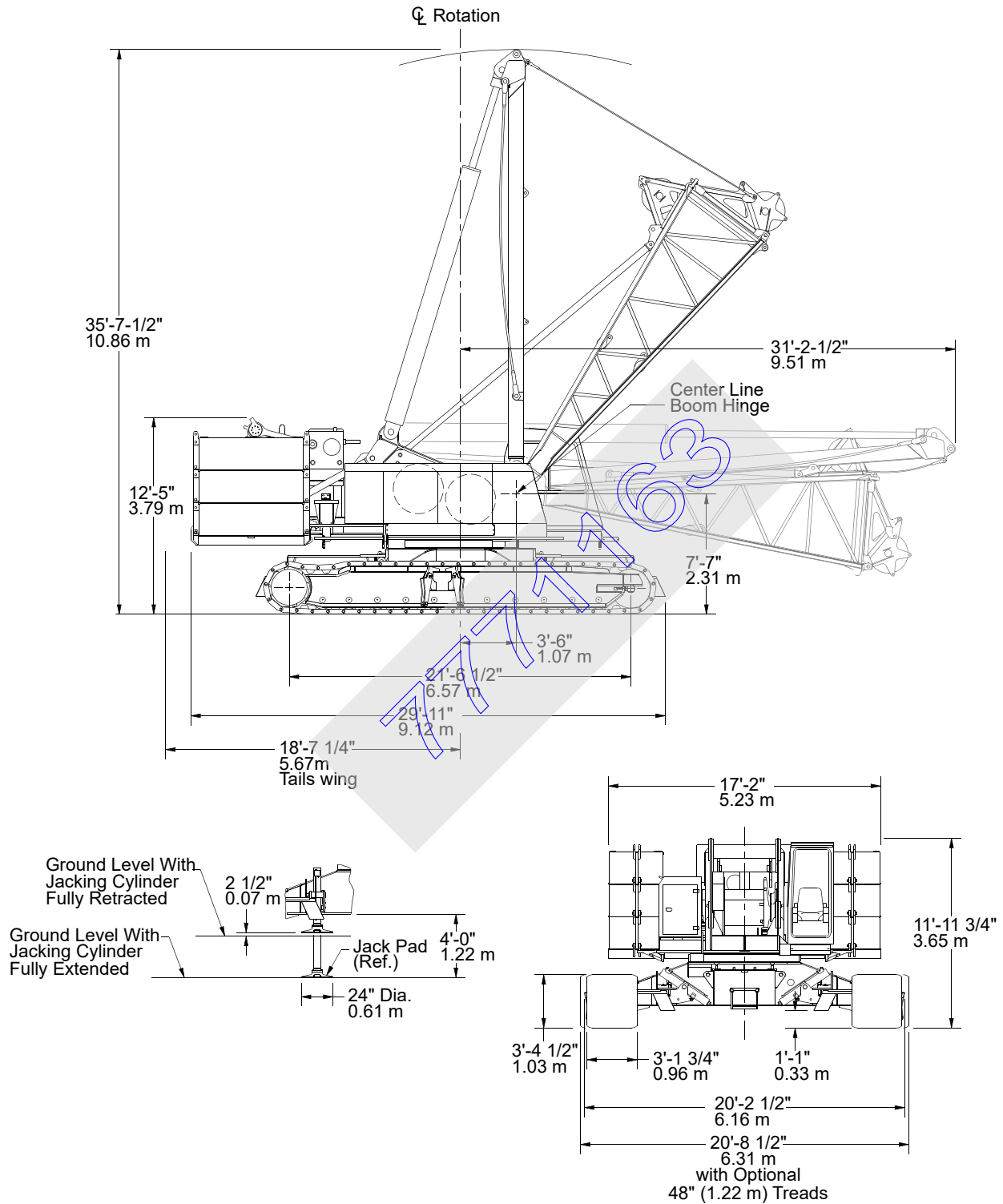

CRANE WEIGHTS

NOTE: Weights may fluctuate ±3% due to manufacturing tolerances.

	Weight	
	Pounds	Kilograms
LIFTCRANE - BOOM NO. 78:		
Rotating bed and carriage complete, 38 in. (965 mm) crawler treads, counterweight, boom hoist cylinders, mast, fully rigged 60 ft (18.3m) boom No. 78 (including upper boom point, 175 USt (160 t) block, and 15 USt (14 t) hook and weight ball), boom stops and maximum length hoist and whip lines		
777 SERIES 1	261,590	118 655
777 SERIES 2	342,710	155 450
ROTATING BED MACHINERY MODULE WITH CARBODY:		
Carbody, rotating bed with two full power drums, operator's cab, boom hoist cylinders, mast, boom butt with integral wire rope guide, carbody jacking arrangement (optional), and maximum length hoist and whip lines		
	86,125	39 065
CRAWLERS:		
24 ft 9 in. (7 544 mm) crawler assembly with 38 in. (965 mm) treads (each)		
	28,210	12 795
24 ft 9 in. (7 544 mm) crawler assembly with 48 in. (1 219 mm) treads (each)		
	33,775	15 320
COUNTERWEIGHT - UPPER:		
Box - side (4 on 777 SERIES 1, 6 on SERIES 2) (each)		
	18,500	8 391
Tray - lower counterweight		
	31,035	14 077
Counterweight pins (each)		
	5	2
Total rotating bed counterweight - 777 SERIES 1		
	105,000	47 627
Total rotating bed counterweight - 777 SERIES 2		
	142,000	64 410
COUNTERWEIGHT HANDLING:		
Counterweight lifting link (each)		
	130	58
Pivot frame with latch, pins and end plates		
	1,080	489
Pendant pivot link		
	335	151
Strut (each) with pins		
	390	176
1-1/4 in. (32 mm) pendant x 6 ft 1-1/2 in. (1.9 m) lg. (each)		
	85	38
1-1/2 in. (38 mm) pendant x 6 ft 1-1/2 in. (1.9 m) lg. (each)		
	135	61
Counterweight hanger pins (each) with end plates		
	40	18
Counterweight rear support pins (each)		
	10	4
Hinge pins (each) on engine base		
	20	9
COUNTERWEIGHT - CARBODY:		
Carbody counterweight (2 on SERIES 2) (each)		
	22,000	9 979
Carbody counterweight steps (each)		
	55	24
BOOM STOP:		
Lower tube (each)		
	145	65
Upper tube (each)		
	300	136
Spring (each)		
	75	34

MAST:

26 ft 0 in. (7 925 mm) mast - - - - -	5,000	2 267
20 ft 0 in. (6.1 m) pendant (each) - - - - -	195	88
16 ft 7-1/2 in. (5.1 m) pendant (each) - - - - -	35	15
Hydraulic boom hoist cylinders - wet (each) with pins - - - - -	4,940	2 240

BOOM NO. 78:

22 ft 6 in. (6.9 m) butt with integral wire rope guide - - - - -	5,755	2 610
37 ft 6 in. (11.4 m) top (with lower point, wire rope guide and pendant links) - - - - -	7,865	3 567
10 ft 0 in. (3.0 m) insert - - - - -	1,275	578
20 ft 0 in. (6.1 m) insert - - - - -	1,950	884
20 ft 0 in. (6.1 m) insert (with jib backstay lugs) - - - - -	2,015	913
40 ft 0 in. (12.2 m) insert - - - - -	3,525	1 598
40 ft 0 in. (12.2 m) insert (with jib backstay lugs) - - - - -	3,590	1 628
37 ft 0 in. (11.3 m) basic pendant (each) - - - - -	175	79
10 ft 1 in. (3.1 m) pendant (each) - - - - -	80	36
20 ft 1-1/2 in. (6.1 m) pendant (each) - - - - -	120	54
40 ft 3 in. (12.3 m) pendant (each) - - - - -	175	79
Intermediate strut - - - - -	605	274
Link - on mast (each) - - - - -	160	72
Wire rope guide (top - 2 sheave) - - - - -	970	439
Timber wire rope guard (each) - - - - -	25	11
Wire rope guide (butt) - - - - -	900	408
Wire rope guide (components of integral rope guide frame on butt) - - - - -	205	92

JIB NO. 134:

15 ft 0 in. (4.6 m) butt - - - - -	580	263
15 ft 0 in. (4.6 m) top (with jib point) - - - - -	990	449
10 ft 0 in. (3.0 m) insert - - - - -	350	158
20 ft 0 in. (6.1 m) insert - - - - -	580	263
30 ft 9 in. (9.4 m) basic pendant (each) - - - - -	115	52
9 ft 6 in. (2.9 m) pendant (each) - - - - -	65	29
19 ft 0 in. (5.8 m) pendant (each) - - - - -	85	38
12 ft 6 in. (3.8 m) strut with sheave - - - - -	665	301
Backstay link (each) attached to strut - - - - -	25	11
Backstay tie link - - - - -	10	4
Backstay link (each) - - - - -	65	29
Backstay spreader - - - - -	50	22
44 ft 7 in. (13.6 m) backstay pendant (each) - - - - -	150	68
4 ft 8 in. (1.4m) backstay pendant (each) - - - - -	50	22
Backstay link (each) attached to boom insert - - - - -	20	9
Jib stop assembly - - - - -	155	70
Wire rope anchor - - - - -	70	31
Winch - - - - -	35	15
Load sensor - - - - -	110	49

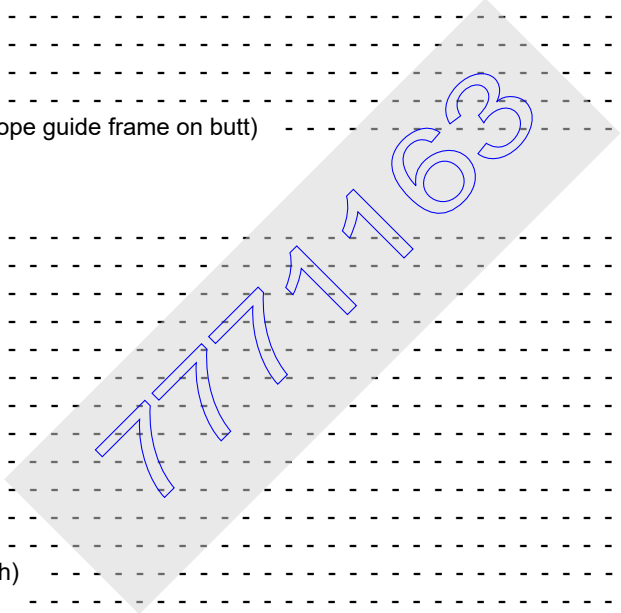

MACHINE OPTIONS:

Cummins M11-C330 power plant (increase over standard) - - - - -	660	299
Free fall for front drum (increase over standard) - - - - -	95	43
Free fall for rear drum (increase over standard) - - - - -	95	43
High line speed arrangement for front drum (increase over standard) - - - - -	1,140	517
High line speed arrangement for rear drum (increase over standard) - - - - -	1,140	517
High line pull arrangement for front drum (increase over standard) - - - - -	1,455	660
High line pull arrangement with free fall for front drum (increase over standard) - - - - -	1,695	769
Lifting arrangement for rotating bed and carbody - - - - -	500	226
Crawler handling arrangement - - - - -	570	258
Carbody jacking arrangement with beams, cylinders and pads - - - - -	2,840	1 288
21-1/4 in. (540 mm) Dia. lagging for 30-1/8 in. (765 mm) wide drum - - - - -	535	242
25-1/4 in. (641 mm) Dia. lagging (high line pull) for 30-1/8 in. (765 mm) wide drum - - - - -	1,055	479
140 ft (42.7 m) of 1 in. (26 mm) self-assembly wire rope - - - - -	260	117

BOOM AND JIB OPTIONS:

Upper boom point (single sheave) - - - - -	920	417
Lower boom point for 1-1/4 in. (32 mm) wire rope (increase over standard) - - - - -	20	9
Auxiliary drum assembly in boom butt - - - - -	3,670	1 664
21-1/4 in. (540 mm) Dia. lagging for auxiliary drum - - - - -	670	303
Wire rope guide (10 ft [3.0 m] insert - required with auxiliary drum) - - - - -	650	294
15 USt (14 t) hook and weight ball - - - - -	1,250	566
30 USt (27 t) load block - - - - -	1,500	680
60 USt (54 t) load block - - - - -	2,825	1 281
175 USt (160 t) load block - - - - -	5,470	2 481

WIRE ROPE:

Load lines - 1 in. rotation resistant wire rope 2.03 lb/ft (3.02 kg/m)		
Hoist line - 1200 ft (366 m) - - - - -	2,435	1 104
Hoist line - 1400 ft (427 m) - - - - -	2,840	1 288
Whip line - 890 ft (271 m) - - - - -	1,805	818
Auxiliary line - 890 ft (271 m) - - - - -	1,805	818
26 mm rotation resistant wire rope 2.13 lb/ft (3.17 kg/m)		
Hoist line - 1200 ft (366 m) - - - - -	2,555	1 158
Hoist line - 1400 ft (427 m) - - - - -	2,980	1 350
Whip line - 890 ft (271 m) - - - - -	1,895	859
Auxiliary line - 890 ft (271 m) - - - - -	1,895	859
32 mm rotation resistant wire rope 3.23 lb/ft (4.81 kg/m)		
Hoist line - 1000 ft (305 m) - - - - -	3,230	1 465
Whip line - 860 ft (262 m) - - - - -	2,780	1 261
1 in. conventional wire rope 1.85 lb/ft (2.75 kg/m)		
Hoist line - 1200 ft (366 m) - - - - -	2,220	1 007
Hoist line - 1400 ft (427 m) - - - - -	2,590	1 175
Whip line - 890 ft (271 m) - - - - -	1,645	746
Auxiliary line - 890 ft (271 m) - - - - -	1,645	746
26 mm conventional wire rope 1.94 lb/ft (2.89 kg/m)		
Hoist line - 1200 ft (366 m) - - - - -	2,330	1 057
Hoist line - 1400 ft (427 m) - - - - -	2,715	1 232
Whip line - 890 ft (271 m) - - - - -	1,725	782
Auxiliary line - 890 ft (271 m) - - - - -	1,725	782
1-1/4 in. conventional wire rope 2.89 lb/ft (4.30 kg/m)		
Hoist line - 1000 ft (305 m) - - - - -	2,890	1 311
Whip line - 860 ft (262 m) - - - - -	2,485	1 127

ENGLISH AND METRIC CONVERSIONS

Direct Conversion

MULTIPLY (x) known value by conversion factor to obtain equivalent value in desired units. For example, 12 ft is converted to meters (m), as follows:

$$12 \text{ ft} \times 0.3048 = 3.6576 \text{ m}$$

Inverse Conversion

DIVIDE (÷) known value by conversion factor to obtain equivalent value in desired units. For example, 3.6576 m is converted to feet, as follows:

$$3.6576 \text{ m} \div 0.3048 = 12$$

To Convert	Symbol	Application	To	Symbol	Multiply By
AREA					
Square Inch	in ²	Filter Area Clutch Contact	Square Centimeter	cm ²	6.4516
Square Foot	ft ²	Ground Contact	Square Meter	m ²	0.0929
FORCE					
Pound Force	lb	Pedal Effort	KiloNewton Newton	kN N	0.00445 4.4482
Pound Force	lb	Line Pull	KiloNewton	kN	0.00445
Pound Force Per Inch	lb/in.	Spring Force	Newton per millimeter	Nmm	0.1751
Pound Force Per Foot	lb/ft		Newton per meter	Nm	14.5939
LENGTH					
Inch	in.	Adjustments	Millimeter	mm	25.4000
Foot	ft	Outline Dimensions	Meter	m	0.3048
Mile	miles	Travel Distance	Kilometer	km	1.6093
POWER					
Horsepower	hp	Engine	Kilowatt	kW	0.7457
PRESSURE					
Pound/Sq. In.	psi	Hydraulic & Air	Bar		0.0689
Degrees Fahrenheit	°F	Oil, Air, Etc.	Degrees Centigrade	°C	°F - 32 ÷ 1.8
Degrees Centigrade	°C		Degrees Fahrenheit	°F	°C x 1.8 + 32
TORQUE					
Inch Pound	in lb	Bolt Torque	Newton Meter	Nm	0.1129
Foot Pound	ft lb		Newton Meter	Nm	1.3558
VELOCITY					
Miles Per Hour	mph	Vehicle Speed	Kilometers Per Hour	km/h	1.6093
Miles Per Hour	mph	Wind Speed	Meters Per Second	m/s	0.4470
Feet Per Minute	fpm	Line Speed	Meters Per Minute	m/min	0.3048
VOLUME					
Cubic Yard	yd ³	Bucket Capacity	Cubic Meter	m ³	0.7646
Cubic Foot	ft ³		Cubic Meter	m ³	0.0283
Cubic Inch	in ³	Pump Displacement	Cubic Centimeter	cm ³	16.3871

To Convert	Symbol	Application	To	Symbol	Multiply By
VOLUME (LIQUID)					
Ounce	oz	Fluid Capacities	Milliliter	mL	29.5735
Pint	pt		Liter	L	0.4732
Quart	qt		Liter	L	0.9464
Gallon	gal		Liter	L	3.7854
Gallon Per Minute	gpm	Pump Flow	Liters Per Minute	L/min	3.7854
WEIGHT					
Pound	lb	Unit/Component	Kilogram	kg	0.4536
US Ton (2000 lb)	USt	Load Ratings	Metric Ton	t	0.9072
US Ton (2000 lb)	USt		Kilogram	kg	907.1847

777163

THIS PAGE INTENTIONALLY LEFT BLANK

777163

SECTION 2

SAFETY INFORMATION

TABLE OF CONTENTS

Continuous Innovation	2-1
Nameplates and Decals	2-1
Safety Messages	2-1
General	2-1
Safety Alert Symbol	2-1
Signal Words	2-1
Symbol Identification	2-1
Safety and Information Signs	2-3
Maintaining Signs	2-3
Ordering Signs	2-3
Crane Access Points	2-4
General	2-4
Getting On or Off Crane	2-4
Personal Fall-Protection	2-6
Operator Manual/Capacity Chart Storage	2-6
General	2-6
Storing Manuals	2-6
Safe Operating Practices	2-7
General	2-7
Work Area Control	2-7
Read Operator Manual	2-7
Operator Qualifications	2-7
Operator Conduct	2-8
Handling Load	2-9
Size of Load	2-9
Attaching Load	2-10
Lifting/Moving Load	2-10
Holding Load	2-11
Signals	2-11
Safety Devices	2-12
Operational Aids	2-12
Category 1 Operational Aids	2-12
Category 2 Operational Aids	2-13
Assembling, Disassembling, or Operating Crane Near Electric Power and Transmission Lines	2-14
Electrocution Hazard	2-14
Set-Up and Operation	2-14
Electrical Contact	2-15
Refueling	2-15
Fire Extinguishers	2-15
Accidents	2-15
Safe Maintenance	2-16
Maintenance Instructions	2-16
Safe Maintenance Practices	2-16
Environmental Protection	2-17
Boom Disassembly Safety	2-19
General	2-19
Location	2-19
Pin Removal	2-19
Disassembly Precaution	2-19
Special Application/Service	2-20
Personnel Handling Policy	2-20



Pedestal/Barge Mounted Cranes	2-21
Pedestal Mounted Crane	2-22
Definition	2-22
Examples	2-22
Barge Mounted Crane	2-22
Definition	2-22
Examples	2-22
Capacity Charts for Barge Mounted Crane	2-23
Shock Loading Caused by Barge Dynamics	2-24
Operation on Barge	2-24
Barge Mount Definitions	2-24
Inspection of Barge-Mounted Crane	2-24
Transporting Crane on Barge	2-25
Pile Driving and Extracting	2-25
Introduction	2-25
Operation of Pile Driving and Extracting Equipment	2-25
Crane Equipment	2-25
Crane Inspection	2-25
Electrocution Hazard Devices	2-26
Multiple Load Line Operation	2-26
Multiple Crane Lifts	2-27

777163

SECTION 2

SAFETY INFORMATION



WARNING

California Proposition 65

Breathing diesel engine exhaust exposes you to chemicals known to the State of California to cause cancer and birth defects or other reproductive harm.

- Always start and operate the engine in a well-ventilated area.
- If in an enclosed area, vent the exhaust to the outside.
- Do not modify or tamper with the exhaust system.
- Do not idle the engine except as necessary.

For more information go to www.P65warnings.ca.gov/diesel.

Batteries, battery posts, terminals, and related accessories can expose you to chemicals, including lead and lead compounds, which are known to the State of California to cause cancer and birth defects or other reproductive harm. Wash hands after handling. For more information go to www.P65warnings.ca.gov.

California Spark Arrestor

Operation of this equipment may create sparks that can start fires around dry vegetation. A spark arrestor may be required. The owner/operator should contact local fire agencies for laws or regulations relating to fire prevention requirements.

CONTINUOUS INNOVATION

Due to continuing product innovation, the information in this manual is subject to change without notice. If you are in doubt about any procedure, contact your Manitowoc dealer or Manitowoc Product Support.

NAMEPLATES AND DECALS

See the drawing at the end of this section.

SAFETY MESSAGES

General

The importance of safe operation and maintenance cannot be over emphasized. Carelessness or neglect on the part of operators, job supervisors and planners, rigging personnel,

and job site workers can result in their death or injury and costly damage to the crane and property.

To alert personnel to hazardous operating practices and maintenance procedures, safety messages are used throughout the manual. Each safety message contains a safety alert symbol and a signal word to identify the hazard's degree of seriousness.

Safety Alert Symbol



This is the safety alert symbol. It is used to alert you to potential personal injury hazards. **Obey all safety messages that follow this symbol to avoid possible death or injury.**

Signal Words



DANGER

Indicates a hazardous situation which, if not avoided, will result in death or serious injury.



WARNING

Indicates a hazardous situation which, if not avoided, could result in death or serious injury.



CAUTION

Used with the safety alert symbol, indicates a hazardous situation which, if not avoided, could result in minor or moderate injury.

CAUTION

Without the safety alert symbol, identifies potential hazards that could result in property damage.

NOTE Highlights operation or maintenance procedures.

Symbol Identification

Many of the symbols used in the safety and information signs and nameplates on this crane are identified in [Table 2-1 on page 2-2](#) and [Table 2-2 on page 2-3](#).

Table 2-1 Common Safety Symbols















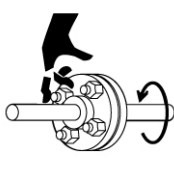

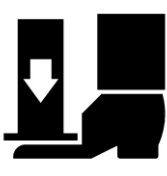







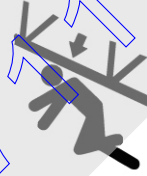

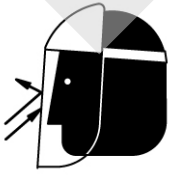

Cut or Crush Hazards					Cut Hazard
 M100090	 M100091	 M100066	 M100065	 M100069	 M100067
Crush Hazards					Fire Extinguisher
 M100070	 M100071	 M100072	 M100073	 M100074	 M100082
Fall Hazards			Falling Boom (Crush) Hazards		Explosion Hazard
 M100083	 M100084	 M100085	 M100068	 M100075	 M100080
Falling Load Hazards		Flying Objects Hazards			Overhead Obstruction Hazard
 M100076	 M100077	 M100088	 M100088	 M100089	 M100081
Electrocution Hazards		Personal Fall Protection	Pressure Cleaning	Sound Power Level	Read Manual
 M100078	 M100079	 M100095	 M100087	 M100096	 M100093

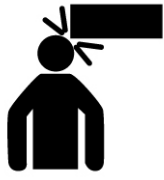
Table 2-1 Common Safety Symbols





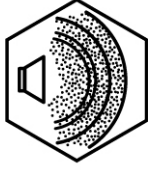









Emergency Cab Exit	Lift	Do Not Lift	Prohibited
 M102486	 M104626	 M104627	 M104628

Table 2-2 Miscellaneous Symbols

Diesel Fuel	Engine Coolant	Engine Coolant Vent	Engine Oil Level	Hydraulic Filter	Hydraulic Oil
 M100271	 M100267	 M100268	 M100269	 M100272	 M100273
Pump Drive Oil Level	Tire Pressure (if equipped)				
 M100270	 M100266	 M101972	 M101973	 M101974	

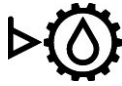
SAFETY AND INFORMATION SIGNS

Maintaining Signs

The crane owner/user shall make sure that all safety and information signs are legible and installed at the proper locations on the crane. If a sign has been defaced or removed, it must be replaced immediately. See the Nameplate and Decal Drawing at the end of this section for the installation locations of signs.

Ordering Signs

Order replacement safety and information signs from your Manitowoc dealer.

When ordering a sign, give the crane model number, the crane serial number, and the name and part number of the sign.

CRANE ACCESS POINTS



WARNING

Crush Hazard!

The upperworks can swing into and crush personnel climbing on or off the crane.

Moving crawlers can crush personnel climbing on or off the crane.

To prevent death or serious injury:

- Barricade all accessible areas to the crane so personnel cannot be struck or crushed when the upperworks is swung.
- Do not climb onto or off the crane while the upperworks is being swung or the crane is being traveled.
- Signal the operator for permission to climb onto/off the crane.
- Operator: do not swing or travel while personnel are climbing onto or off the crane. Stop the swing and travel motions. Apply the swing brake and turn on travel park.
- Operator: Always sound the horn to alert personnel before you swing or travel.
- Automatic alarms will sound to alert personnel when the crane is swung or traveled.

NOTE If the swing and travel alarms are not operating properly, they must be repaired as soon as possible. Until they are repaired, the operator shall alert personnel to crane movement using the horn on the control console.

General

Take necessary precaution to prevent slipping and/or falling off the crane during assembly, disassembly, maintenance, or other work. **Falling from any height could result in serious injury or death.**

Manitowoc has provided a ladder, steps, platforms, and catwalks at the locations shown in

The owner/user shall provide workers with approved ladders or aerial work platforms to access those areas of the crane, gantry, and boom that cannot be reached from the ground or from the ladder, steps, platforms, and catwalks provided by Manitowoc.

Adhere to local, state, and federal regulations for handling personnel and for personnel fall protection.

- Access points must be kept clear to prevent personal injury and unsafe operation of the crane. Store clothing and other personal belongings so they do not interfere with controls in operator cab or with operation of the crane.
- Do not allow ground personnel to store their personal belongings (clothing, lunch boxes, water coolers, and the like) on the crane.

This practice will prevent ground personnel from being crushed or electrocuted when they attempt to access personal belongings stored on the crane.

- Tools, oil cans, spare parts, and other necessary equipment must be stored in tool boxes or other appropriate locations. Do not allow these items to lie around loose in operator cab or on steps, ladders, catwalks, and platforms.
- To reduce risk of slipping, non-skid material (sand in paint) has been applied to painted walkways and platforms.
- Walkways and platforms can be slippery when wet and when oil or is grease is spilled on them. **Keep walkways and platforms clean and dry to prevent slipping on them.** When non-skid material wears out, reapply it.
- Wear shoes with a highly slip-resistant sole material. Clean any mud or debris from shoes before entering the crane cab or climbing onto the cab. A shoe that is not clean might slip off a control pedal during operation.
- Do not make modifications or additions to the crane's access system that have not been evaluated and approved by Manitowoc.

GETTING ON OR OFF CRANE

Personnel getting on and off the crane shall do so only:

- at the steps or ladders provided,
- while crane is parked and not moving,
- with the operator's or qualified person's permission,
- if the performance of their duties requires them to do so.

When personnel use the steps and ladders to get on or off the crane, their hands shall be free of any objects. Objects which cannot be carried in pockets or tool belts shall be lifted into place with a hand line or hoist.

Always maintain a three-point contact with the ladder: two feet and one hand or two hands and one foot.

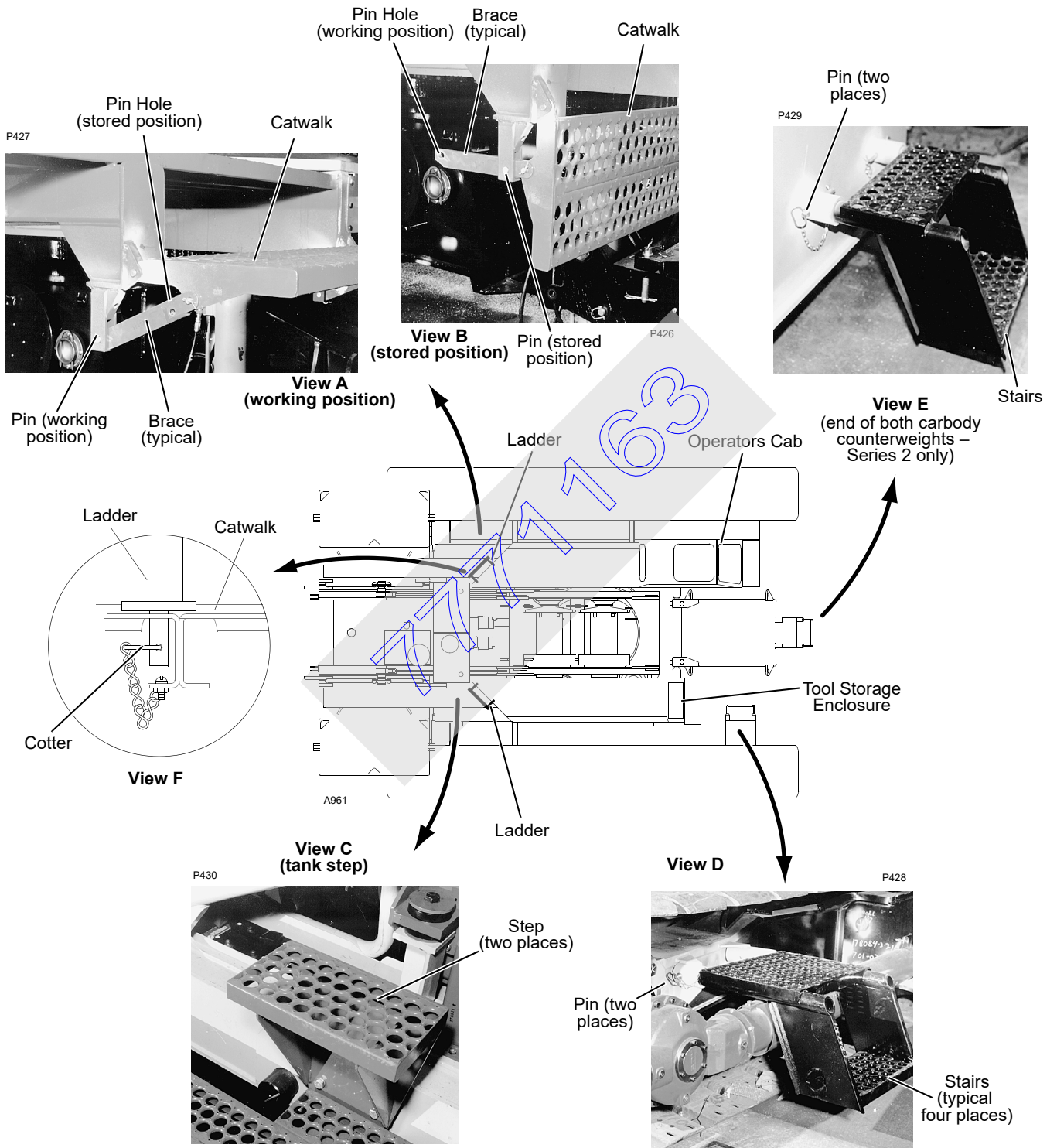

Figure 2-1. Crane Access Points

PERSONAL FALL-PROTECTION

It is the crane owner/user's responsibility to provide assembly/maintenance personnel with appropriate fall-protection equipment.

WARNING Fall Hazard!

To prevent falling from any height during crane assembly and disassembly, personnel shall appropriately wear fall-protection equipment.

OPERATOR MANUAL/CAPACITY CHART STORAGE

General

Manitowoc provides the following manuals and other important literature with your crane:

- Operator Manual (Serial Numbered)
Contains safety information, crane specifications, assembly/erection procedures, operating instructions, lubrication and maintenance checks.
- Parts Manual (Serial Numbered)
Contains illustrations and part numbers of replaceable parts.
- Capacity Chart Manual (Serial Numbered)
Contains lifting capacities and related information (wire rope specifications, drum and lagging information, etc.)
- Maintenance Checks and Lube Guide
Contains lists of maintenance checks and lube services and their prescribed intervals.
- RCI/RCL Operation
Contains rated capacity indicator and/or rated capacity limiter operation, limits, and calibration procedures.
- Service Manual (Serial Numbered)
Contains theory of operation, maintenance procedures, crane and wire rope inspection procedures, troubleshooting information, and shop procedures.

The manuals which must be retained in the operator cab (Operator Manual, Capacity Charts, Maintenance Checks and Lube Guide, and RCL Operation) are supplied in an OPERATOR INFORMATION binder.

The Operator Manuals and Capacity Charts are stamped with the serial number of the crane or attachment. The serial number on the manuals and capacity charts must match the serial number of the crane. **Using any other manual or capacity chart is prohibited.**

The crane model and serial number are located on the Crane Identification Plate on the crane cab.

If the serial numbers of your manuals and capacity charts do not match the serial numbers of the crane, contact your Manitowoc dealer for the proper manual or capacity charts.

Do not operate the crane if the proper Capacity Chart is not in the cab.

Storing Manuals

See [Figure 2-2](#).

Store the Operator Information Manuals for the crane and each applicable attachment on the bookshelf in the Operator's cab.

Attach the chain from the manual in use to the link behind the operator's seat.

Keep all other manuals provided with the crane in the crane owner's/user's office so they are readily available when needed.



Figure 2-2.

SAFE OPERATING PRACTICES

General

The importance of safe operation cannot be over emphasized. Carelessness and neglect on the part of operators, supervisors and planners, rigging personnel and job site personnel can result in their death or injury and costly damage to the crane or property.

The safety information in this publication is intended only as a guide to assist qualified operators, supervisors and planners, rigging personnel, and job site personnel in safe operation. Manitowoc cannot foresee all hazards that will arise in the field; therefore, **safety remains responsibility of crane operators and owner.**

Local, state, and other governmental agencies may require stricter operating practices. When a conflict in practices exists, follow the strictest practice.

Work Area Control

Personnel within the swing radius of the crane and fall zone of the crane's boom and/or load are subject to hazards if the crane is not operated per the requirements of the manufacturer and industry recognized safe operating practices.

To minimize the risk of harm, training of personnel on jobsite hazard recognition and prevention is required. Additionally, restricting access to the swing radius and fall zone during specific work conditions is required. The U.S. Department of Labor, Occupational Safety and Health Administration (OSHA) regulations for Construction provides requirements in 29CFR1926.1417 Operation, 29CFR1926.1424 Work area control, 29CFR1926.1425 Keeping clear of the load and 29CFR1926.1426 Free fall and controlled load lowering.

Read Operator Manual

Safe and efficient assembly, disassembly, and operation of this crane requires that it be maintained in proper working order and that its operators and maintenance personnel be familiar with the crane's functions and capabilities.

The Operator Manual supplied with and considered part of your crane must be read and completely understood by each person responsible for assembly, disassembly, operation, and maintenance of the crane.

The Operator Manual must be read to personnel who cannot read or understand English or other language into which the manual is translated.

Because of a program of continuing improvement in product design, Manitowoc reserves the right to change the information and specifications contained in the Operator

Manual at any time without notice. If you have any questions regarding the crane or its Operator Manual, please contact your Manitowoc dealer or Manitowoc Product Support.

Operator Qualifications

The crane must be operated only by the following **qualified** personnel:

1. Designated operators.
2. Trainees under direct supervision of a designated operator.
3. Supervisors, inspectors, and maintenance or test personnel when necessary in performance of their duties. Operation of the crane by these personnel shall be limited to the crane functions needed to perform the inspection or to verify the crane's performance after maintenance procedures.

No personnel shall be allowed to climb onto the crane or enter cab unless performance of their duties requires them to do so, and then only with knowledge of operator or other qualified person.

Qualified person is defined as one who by reason of training and experience is thoroughly familiar with crane operations and the hazards involved. Such a person shall meet the operator qualifications specified in Occupational Safety and Health Administration (OSHA) Regulations (United States Federal Law), in ASME B30.5 American National Standard, or in any other applicable federal, state, or local laws.

Operator training and qualification is crane owner's responsibility.

NOTE The regulations and standards mentioned above and later in this section can be obtained from:

US DOL/OSHA Rules and Regulations are available by mail from the Superintendent of Documents, PO Box 371954, Pittsburgh, PA, 15250-7954 or by:

- Phone 202-512-1899
- Fax 202-512-2250
- Online at www.osha.gov

ASME (formerly ANSI) B30 Series American National Standards are available by mail from the ASME, 22 Law Drive, Fairfield, New Jersey, 07004-2900 or by:

- Phone US & Canada 800-843-2763
- Phone Mexico 95-800-843-2763
- Phone Universal 973-882-1167
- Fax 973-882-1717 or 973-882-5155

- E-mail infocentral@asme.org

Operator Conduct

1. The operator shall not engage in any practice which diverts his/her attention while operating the crane.
2. The operator shall not operate the crane when he/she is physically or mentally unfit.
3. The operator shall be responsible for all operations under his/her direct control. When safety of an operation is in doubt, the operator shall stop the crane's functions in a controlled manner. Lift operations can resume only after safety concerns have been addressed or the continuation of crane operations is directed by the lift supervisor.
4. The operator shall be thoroughly familiar with operation of the crane and its proper care. If adjustments or repairs are necessary or if there are known defects that impair safe operation, the crane must not be operated until unsafe conditions have been corrected.
5. If there is a warning sign at the start controls, the operator shall not start the engine until the warning sign has been removed by the person who installed it.
6. Before starting the engine, the operator shall make sure that:
 - a. All daily inspection and maintenance services have been performed.
 - b. All controls are in the off position and all brakes and locking devices are applied or engaged.
 - c. All personnel are clear of the crane. Deploy a swing radius barrier.
7. The operator shall test all controls, limits, and communication systems at the start of each shift. Any defects found must be corrected before operation is begun.
8. The operator shall not start crane movement if the load or designated signal person is not within his/her range of vision or communication.
9. The operator shall understand and respond to signals from the person directing the lift or from the designated signal person. When a signal person or crane follower is not required, the operator is responsible for the lift. **Operator shall obey a stop signal at all times, no matter who gives it.**
10. The operator shall verify that the Capacity Chart being used is the correct one for the cranes configuration (boom length, load line reeving, counterweight, etc.).
11. The operator shall verify that:
 - a. All attachments are properly assembled and attached to the crane according to the rigging drawings called for in the Capacity Chart.
 - b. The counterweight — to include applicable auxiliary counterweight — is in place and of proper weight. **Maximum required counterweight must not be exceeded.**

WARNING

Safety devices and operational aids such as rated capacity indicator or limiter, boom and jib angle indicator or limiter, anti-two-block device, level indicator, swing limiter, proximity device, etc., may be installed on your crane. Such devices are to be used only as **AIDS TO ASSIST OPERATOR**; their presence on the crane in no way substitutes for or lessens requirement that operator knowledge, experience, and judgment are required to ensure safe operation of the crane.

Crane must not be loaded beyond applicable static or dynamic ratings given in Capacity Chart for crane.

- See Size of Load later in this section.
- For a description of each safety device and operational aid, see Section 3 of the MLC100-1 Operator Manual.



WARNING

Moving Load/Tipping Crane Hazard!

Changing weather conditions including, but not limited to: wind, ice or snow accumulation, precipitation, flooding, lightning, etc. should be considered when determining the location and configuration of a crane when it will be left unattended.

12. The operator shall perform the following operations before leaving the operator cab for any reason:
 - a. Park the crane and position upperworks so the crane does not interfere with operation of other equipment.
 - b. Apply travel and swing brakes or locking devices.
 - c. Land any attached load.
 - d. Lower the boom onto blocking at ground level or onto a boom rest if possible.

If the boom cannot be lowered, as determined by a qualified designated person, it must be securely fastened from movement by wind or other outside forces (see Wind Conditions in Capacity Chart Manual).

NOTE The designated person shall be familiar with the job site limitations, the crane configuration, and the expected weather conditions.

- e. Move all controls to off.
- f. Apply all drum brakes and pawls.
- g. Disengage the master clutch, if equipped.
- h. Stop the engine.

NOTE Also read Unattended Crane instructions in Section 3 of the Crane Operator Manual.

13. The operator shall perform the following operations if power or a control function fails during operation:
- a. Land all suspended loads, if possible, under brake or power control.
 - b. Apply all brakes and locking devices.
 - c. Move all controls to off.
14. If the crane will be operated at night, the operator shall make sure that there is sufficient lighting for safe operation. The load and landing area must be illuminated.
15. The operator shall not operate the crane during periods of bad weather if his/her ability to see the load or the signal person is impaired by darkness, fog, rain, snow, and the like.

Do not operate the crane with a snow or ice covered boom. The extra weight may cause overload, tipping, or structural damage.

Never operate the crane during an electrical thunderstorm.

When a local weather storm warning exists (including electrical thunderstorm), stop operation and secure the crane. See step 12 on page 2-8.

NOTE DO NOT depend on grounding. Grounding of a crane affords little or no protection from electrical hazards. The effectiveness of grounding is limited by the size of the conductor (wire) used, condition of the ground, the magnitude of voltage and current present, and numerous other factors.

16. Wind can cause the crane to tip or the boom and other attachments to collapse. The operator or qualified person directing the lift shall compensate for the effect of wind on the load and boom by reducing ratings, reducing operating speeds, or a combination of both.

Unless otherwise specified in the Capacity Chart, or Operator Manual, stop operation under the following wind conditions:

- a. If the wind causes the load to swing forward past the allowable operating radius or sideways past either

boom hinge pin, land the load and apply the drum brakes.

- b. If the wind exceeds 16 m/s (35 mph), land all loads and apply the drum brakes, lower the boom onto blocking at ground level or otherwise restrain it, and apply the swing and travel brakes and/or locks.

NOTE “*Land load*” means to set it down on a firm uniformly supporting surface.

17. Booms, jibs, or masts which are being assembled or disassembled on the ground (with or without support of boom rigging) must be securely blocked to prevent the boom, jib, or mast sections from dropping.

Workers shall not go under boom, jib, or mast sections when removing connecting pins or bolts.

18. Each outrigger must be visible to the operator or the signal person during extension and retraction.

Handling Load

Size of Load

1. The crane must not be loaded beyond the applicable static or dynamic ratings given in the Capacity Chart for the crane configuration.
2. The ratings given in the Capacity Chart are developed based on “Freely suspended loads” and specified operating conditions. When cranes are used for service other than lifting service and/or special lifting operations, Manitowoc or a qualified person shall establish the ratings, operating limitations, maintenance, testing, and inspection requirements. Please reference Special Application/Service later in this section.

NOTE “*Freely suspended load*” is a load that is hanging free with no direct external force applied except by the crane’s load-line reeving.

To determine the actual weight of the load which can be lifted at a given radius (working load), the operator shall deduct the weight of certain lifting equipment from the total weight given in the chart. See the specific Capacity Chart for your crane for a list of lifting equipment which must be deducted.

The operator’s judgment shall be used to further reduce total load to allow for the dynamic effects of swinging, hoisting, or lowering, and adverse weather conditions to include wind.

3. The operator or other designated person directing the lift shall verify that the weight of load is within the static or dynamic rating for radius at which load will be lifted.

Verified weights and measured radii must take priority over RCI/RCL readings.

Attaching Load

1. Attach the hook to the load with slings, or other suitable rigging. Each hook must have a latch that is in proper working order. **Hook latches must not be wired open.**
 - a. Inspect each hook and latch before using.
 - b. Never use a hook or latch that is distorted or bent.
 - c. Make sure spring will force the latch against the tip of the hook.
 - d. Make sure the hook supports the load. The latch must never support the load. Latches are only intended to retain loose slings under slack conditions.
2. Only use slings and other rigging that are in safe operating condition and have a rating equal to or greater than the load to be lifted.
3. Do not wrap the load line around the load.
4. Use suitable protection between slings and any sharp edges on the load. When synthetic slings are used, the synthetic sling manufacturer's instructions, limitations, specifications, and recommendations must be followed.
5. Secure unused legs of a multi-leg sling before handling a load with one leg of sling.

Lifting/Moving Load

1. Before lifting or moving a load, the operator or qualified person directing the lift shall make the following checks:
 - a. Crane has a firm, uniformly supporting foundation under all crawlers. Unless otherwise specified in the Capacity Chart, the foundation must be level to within 1% — 0,3 m (1ft) rise or fall in 30,5 m (100 ft) distance.

When such a surface is not available, it must be provided with timbers, cribbing, or other structural members to distribute the load such that the allowable bearing capacity of the underlying member is not exceeded.

For ground bearing data go to: www.manitowoc.com
 - b. The load is secured and properly balanced in the slings or the lifting device before lifting the load more than 76 to 152 mm (3 to 6 in).
 - c. The lift and swing paths are clear of personnel and obstructions.
 - d. The load is free to be lifted.
 - e. The load line is not kinked or otherwise damaged.
 - f. Multiple part load lines are not twisted around each other in such a manner that the lines will not separate when the load is lifted.

- g. The hook is brought over the load in a manner that will minimize twisting or swinging.
 - h. The load line and the boom hoist rope are properly spooled on the drums and seated in the sheaves.
 - i. The load drum brakes are in proper working order.

The operator shall test the load drum brakes each time a load approaching the rated load is handled. Lift the load 76 to 152 mm (3 to 6 in) and fully apply the brakes — load must not lower through applied brakes.
 - j. Unused load drums are parked (working and parking brakes applied; if equipped, drum pawls engaged).
 - k. All personnel are clear of the swing radius of the crane's counterweight.
2. While lifting or moving the load, the operator shall take the following precautions:
 - a. Accelerate and decelerate the load smoothly to avoid excessive stress on the boom and machinery.
 - b. Avoid sudden starts and stops while swinging. Keep the swing speed under control to prevent the load from swinging out beyond the radius at which the load can be handled and to minimize the pendulum action of the load.
 - c. When lifting, any non-vertical loads applied to the crane from dynamics, multi-crane lifts or environmental factors must be minimized or eliminated. The load must remain under the lifting point at all times.
 - d. Sound the signal horn before swinging and intermittently while swinging, especially when approaching personnel.

If equipped, the automatic swing alarm will sound when the crane is swung.
 - e. Use taglines or other restraints to control the load when necessary.
 - f. Do not exceed any swing limitations (areas of operation) given in the Capacity Chart.
 - g. Do not allow the load, boom, or any other part of the crane to contact obstructions.
 - h. Do not use the crane to drag a load.
 - i. Do not hoist, lower, or swing the load while personnel are on the load or the hook. See Personnel Handling in this section.
 - j. Avoid carrying the load over personnel. Loads which are suspended must be blocked or cribbed before personnel are allowed to work under or between them.

- k. Before lifting a load which requires the use of outriggers (or anytime outriggers are used), fully extend the outrigger beams and jacks so the truck tires do not bear any load.

Securely fasten the outrigger jack pads or floats to jacks and set them on a flat, firm surface that will support the load placed on the pads or floats. Do not set the jack pads or floats in holes, on rocky ground, or on extremely soft ground.

When dictated by ground conditions, install wood blocking or steel plates under the jack pads or floats to properly distribute the loading on the supporting surface.

Wood blocking or steel plates used under the jack pads or floats must be:

- Free of defects
- Strong enough to prevent crushing, bending, or shear failure
- Of sufficient thickness, width, and length to completely support the jack pad or float, transmit the load to the supporting surface, and prevent shifting, toppling, or excessive settlement under load.

- l. Fully retract and lock the jacks and the outrigger beams so they cannot extend when not in use.
- m. Do not lower the load or the boom to a point where less than three full wraps of wire rope remain on the respective drum (or as otherwise indicated in local, state, or federal regulations).
- n. Engage the boom hoist pawl when operating with the boom at a fixed radius.
- o. Engage the luffing hoist pawl when operating with the luffing jib at a fixed radius.

- 3. While traveling, the operator shall take the following precautions:

- a. Sound the signal horn before traveling and intermittently while traveling, especially when approaching personnel.

If equipped, the automatic travel alarm will sound when the crane is traveled.

- b. Carry the boom in-line with the lowerworks and facing the direction of travel.
- c. Do not position the boom so high that it could bounce over backwards whether traveling with or without load.
- d. Secure the rotating bed against rotation except when it is necessary to negotiate a turn, and then only when the operator is seated at controls or the boom is supported on a dolly.

- e. Lash or otherwise restrain unused hooks so they cannot swing freely.

- 4. Before traveling with a load, the operator shall take the following additional precautions:

- a. A designated person shall be responsible for operation. Decisions such as the necessity to reduce crane ratings, load position, boom position, ground support, and speed of movements must be in accordance with the designated person's decision.
- b. Maintain specified tire pressures (truck cranes).
- c. Avoid sudden starts and stops. Use taglines or other restraints to control the position of the load.

Holding Load

When a load is suspended, the operator shall take the following precautions:

1. Not leave his/her position at the controls
2. Not allow personnel to stand or pass under the load
3. Move all controls to off, apply all drum brakes, engage the boom hoist pawl, and apply the swing and travel brakes or locks.

SIGNALS

1. Continuous communication must be maintained between the operator and the signal person during all crane movements. If communication is disrupted, **operator shall stop all crane movements.**
2. Signals to the operator must be in accordance with the standard signals shown in Section 3, unless communications equipment (telephone, radio, etc.) is used.
3. All signals must be easily understood by the operator at all times. The operator shall not respond to any signal which is not clearly understood.
4. For operations not covered in the standard signals, or for special situations or emergencies, additional signals may be required. In those cases, the signals used must be agreed upon in advance by the operator and the signal person. The signals used must not conflict with or have potential to be confused with the standard signals.
5. When it is necessary to give instructions to the operator (other than those established by the signal system), all crane motions must be stopped.
6. The signal person shall:
 - a. Be tested by a designated person and show that he or she has a basic understanding of crane operations and limitations, to include boom deflection.

- b. Be thoroughly familiar with the standard hand signals and voice signals if used.
 - c. Be positioned in clear view of the operator. The signal person's position should give him or her a clear view of the load, the crane, and the operating area.
 - d. Direct the load so it does not pass over personnel.
 - e. Keep unnecessary personnel out of the crane's operating area.
7. When moving the crane, the following audible signals must be used:
- a. STOP - one short audible signal
 - b. GO AHEAD - two short audible signals
 - c. BACK UP - three short audible signals
3. Cranes operating on a barge require: a trim indicator, a swing brake, and a wind direction indicator if the wind is a factor (supplied by crane owner or user).
 4. Boom stops, both physical and automatic
If a boom stop is damaged or not working properly, it must be tagged-out or removed if possible.
 5. Jib stops, both physical and automatic (for fixed jib and luffing jib)
If a jib stop is damaged or not working properly, it must be tagged-out or removed if possible.
 6. Pedal locks for all foot-operated brakes (if applicable)
If a pedal lock is damaged or not working properly, it must be tagged-out or removed if possible.
 7. An integral holding device or check valve on each jacking cylinder.

SAFETY DEVICES



WARNING

Do not operate the crane unless all safety devices listed in this section are in proper working order.

- If a safety device stops working properly during operation, the operator shall safely stop operation.
- If any safety device listed in this section is not in proper working order, the safety device must be taken out of service and crane operation must not resume until the safety device is again working properly.
- Alternative measures are not permitted to be used for a faulty safety device.
- Always tag-out any faulty safety device and place a warning tag in the cab stating that the crane is out of service and must not be used.

Manitowoc provides the following safety devices on its cranes.

1. Horn activated by a switch on the control console in the operator cab
If the horn is not working properly, it must be tagged-out or removed if possible.
2. Crane level indicator: either electronic (viewable in crane's electronic display) or mechanical (viewable from operator cab seat). If the crane level indicator is not working properly, it must be tagged-out or removed, if possible.

OPERATIONAL AIDS



WARNING

Do not operate the crane unless all applicable operational aids listed in this section are in proper working order, except:

- Where an operational aid is being repaired
- The crane user implements a specified temporary alternative measure.

If an operational aid stops working properly during operation, the operator shall safely stop operation until the temporary alternative measures are implemented or the device is again working properly.

Manitowoc provides the following operational aids on its cranes, either as standard equipment or optional equipment. The operational aids are designated as Category 1 or Category 2:

Category 1 Operational Aids

If a Category 1 operational aid is not working properly, it must be repaired no later than 7 calendar days after the deficiency occurs.

Exception: If the crane user documents that he/she has ordered the necessary parts within 7 calendar days of the occurrence of the deficiency, the repair must be completed within 7 calendar days of receiving the parts.

1. Boom or Luffing Jib Angle Limiter

(automatic boom or jib stop)

Temporary alternative measures if inoperative or malfunctioning:

The qualified person directing the lift shall make sure the maximum boom or jib angle/radius specified in the Capacity Chart for the load being handled is not exceeded. One or more of the following methods must be used:

- a. Measure radius using a tape measure.
- b. Measure the boom angle with a protractor-level on the centerline of boom.
- c. Clearly mark the boom or luffing hoist cable (so it can easily be seen by the operator) at a point that gives the operator sufficient time to stop the boom or jib within the minimum allowable radius.

In addition, install mirrors or remote video cameras and displays if necessary for the operator to see the mark.

- d. Clearly mark the boom or luffing hoist cable (so it can easily be seen by a designated signal person) at a point that gives the signal person sufficient time to signal the operator and have the operator stop the boom or jib within the minimum allowable radius.

2. Anti-Two-Block Device

Temporary alternative measures if inoperative or malfunctioning:

The qualified person directing the lift shall establish procedures to furnish equivalent protection. One or more of the following methods must be used:

- a. Assign a signal person to signal the operator to stop hoisting when the load is a safe distance from the boom or jib point.
- b. Clearly mark the hoist cable (so it can easily be seen by the operator) at a point that will give the operator sufficient time to stop the load a safe distance from the boom or jib point.

The temporary alternative measures for the anti-two-block device do not apply when lifting personnel in load line supported baskets.

Personnel shall not be lifted in load line supported baskets when anti-two-block devices are not functioning properly.

Category 2 Operational Aids

If a Category 2 operational aid is not working properly, it must be repaired no later than 30 calendar days after the deficiency occurs.

Exception: If the employer documents that he/she has ordered the necessary parts within 7 calendar days of the occurrence of the deficiency, and the part is not received in time to complete the repair in 30 calendar days, the repair must be completed within 7 calendar days of receiving the parts.

1. Rated Capacity Indicator/Limiter

Temporary alternative measures if inoperative or malfunctioning:

The qualified person directing the lift shall establish procedures for determining load weights and shall make sure that the weight of the load does not exceed the crane's rating at the radius where the load is handled.

The weight of the load must be provided to the operator before the lift is made.

2. Boom Angle or Radius Indicator

Temporary alternative measures if inoperative or malfunctioning:

- a. Refer to the pendulum boom angle indicator on the boom butt (visible from operator cab).
- b. Measure the boom angle with a protractor-level on the centerline of boom.
- c. Measure radius using a tape measure.

3. Jib Angle or Radius Indicator

Temporary alternative measures if inoperative or malfunctioning. Use either or both:

- a. First, make sure you know the boom angle (see item [2](#) above).
- b. Then, measure radius using a tape measure.

4. Drum Rotation Indicator

Temporary alternative measures if inoperative or malfunctioning:

Mark the drum to indicate its rotation.

If the operator cannot see the drum, add mirrors or remote video cameras and displays so the operator can see the mark.

5. OPTIONAL Swing Limiter or Proximity Device

Temporary alternative measures if inoperative or malfunctioning:

The qualified person directing the lift shall establish procedures to furnish equivalent protection (for example, assign an additional signal person to observe the distance between the boom or load and job site obstructions to include power lines or to limit the swing sector specified in the Capacity Chart).

6. OPTIONAL Drum Spooling Limiter (maximum or minimum bail limit)

Temporary alternative measures if inoperative or malfunctioning:

The qualified person directing the lift, the operator, or a designated signal person shall watch the drum and signal the operator to stop it before it is over spooled (rope does not jump off drum) or before there are less than 3 full wraps of wire rope on the load drum or boom hoist.

7. OPTIONAL Closed-Circuit Television (CCTV)

Temporary alternative measures if inoperative or malfunctioning:

A designated signal person shall watch the load, the drums, and the counterweight and provide necessary hand or voice signals to the crane operator.

ASSEMBLING, DISASSEMBLING, OR OPERATING CRANE NEAR ELECTRIC POWER AND TRANSMISSION LINES

Electrocution Hazard

Thoroughly read, understand, and abide by all applicable federal, state, and local regulations regarding operation of cranes near electric power lines or equipment.

United States federal law prohibits the use of cranes closer than 6 m (20 ft) to power sources up to 350 kV and greater distances for higher voltages unless the line's voltage is known [29CFR1910.180 and 29CFR1926.1400].

To avoid death or serious injury, Manitowoc recommends that all parts of the crane, boom, and load be kept at least 6 m (20 ft) away from all electrical power lines and equipment less than 350 kV.

NOTE For detailed guidelines on operating near power lines, refer to the current edition of OSHA 29CFR1926.1400 and ASME B30.5 American National Standard.



WARNING

Electrocution Hazard!

Manitowoc cranes are not equipped with all features required to operate within OSHA 29CFR1926.1408, Table A clearances when the power lines are energized.

1. Keep all personnel and their personal belongings (clothing, water coolers, lunch boxes, etc.) away from

the crane if it is being operated near electrical power lines or equipment.

2. Before operating the crane in the vicinity of electrical power lines or equipment, notify the power utility company. Obtain positive and absolute assurance that the power has been turned off.

The crane is NOT INSULATED. Always consider all parts of the load and the crane as conductors, including the wire rope, pendants or straps, and taglines.

Most overhead power lines ARE NOT insulated. Treat all overhead power lines as being energized unless you have reliable information to the contrary from the utility company or owner.

The rules in this section must be followed at all times, even if the electrical power lines or equipment have been de-energized.

3. Crane operation is dangerous when close to an energized electrical power source. Exercise extreme caution and prudent judgment. Operate slowly and cautiously when in the vicinity of power lines.
4. If the load, wire rope, boom, or any portion of the crane contacts or comes too close to an electrical power source, everyone in, on, and around the crane can be seriously injured or killed.

The safest way to avoid electrocution is to stay away from electrical power lines and electrical power sources.

5. The operator is responsible for alerting all personnel to the dangers associated with electrical power lines and equipment. The crane is not insulated. Do not allow unnecessary personnel in the vicinity of the crane while operating. Permit no one to lean against or touch the crane. Permit no one, including riggers and load handlers, to hold the load, load lines, taglines, or rigging gear.
6. Even if the crane operator is not affected by an electrical contact, others in the area may become seriously injured or killed.
7. It is not always necessary to contact a power line or power source to become electrocuted. Electricity, depending on magnitude, can arc or jump to any part of the load, load line, or crane boom if it comes too close to an electrical power source. Low voltages can also be dangerous.

Set-Up and Operation

1. During crane use, assume that every line is energized ("hot" or "live") and take necessary precautions.
2. Position the crane such that the load, boom, or any part of the crane and its attachments cannot be moved to within 6 m (20 ft) of electrical power lines or equipment.

This includes the crane boom and all attachments. Overhead lines tend to blow in the wind, so allow for movement of the overhead lines when determining a safe operating distance.

3. Erect a suitable barricade to physically restrain the crane, all attachments, and the load from entering into an unsafe distance from electrical power lines or equipment.
4. Plan ahead and always plan a safe route before traveling under power lines. A wooden clearance frame should be constructed to ensure sufficient clearance is maintained between crane and power lines.
5. Appoint a reliable and qualified signal person, equipped with a loud signal whistle or horn and voice communication equipment, to warn the operator when any part of the crane or load moves near a power source. This person should have no other duties while the crane is working.
6. Taglines should always be made of non-conductive materials. Any tagline that is wet or dirty can conduct electricity.
7. DO NOT store materials under power lines or close to electrical power sources.
8. When operating near transmitter/communication towers where an electrical charge can be induced into the crane or load:
 - The transmitter must be deenergized OR,
 - Tests must be made to determine if an electrical charge will be induced into the crane or load.
 - The crane must be provided an electrical ground.
 - If taglines are used, they must be non-conductive.
 - Every precaution must be taken to dissipate induced voltages. Consult with a qualified RF (radio frequency) Consultant. Also refer to local, state, and federal codes and regulations.

Electrical Contact

If the crane comes in contact with an energized power source, the operator shall:

1. Stay in the crane cab. DON'T PANIC.
2. Immediately warn PERSONNEL in the vicinity to STAY AWAY.
3. Attempt to move the crane away from the contacted power source using the crane's controls which are likely to remain functional.
4. Stay in the crane until the power company has been contacted and the power source has been de-energized.

NO ONE shall attempt to come close to the crane or load until the power has been turned off.

Only as a last resort should an operator attempt to leave the crane upon contacting a power source. If it is absolutely necessary to leave the cab, JUMP COMPLETELY CLEAR OF CRANE. DO NOT STEP OFF. Hop away with both feet together. DO NOT walk or run.

5. Following any contact with an energized electrical source, your Manitowoc dealer shall be immediately advised of the incident and consulted on necessary inspections and repairs.

If the dealer is not immediately available, contact Manitowoc Product Support. The crane must not be returned to service until it is thoroughly inspected for any evidence of damage and all damaged parts are repaired or replaced as authorized by Manitowoc or your Manitowoc dealer.

REFUELING

1. When using a portable container to refuel the crane, the container must be a safety-type can equipped with an automatic closing cap and a flame arrester.
2. The engine must be **stopped** before refueling the crane.
3. Smoking and open flames must be prohibited in refueling area.

FIRE EXTINGUISHERS

1. A portable fire extinguisher with a minimum rating of 10 BC must be installed in operator's or machinery cab of the crane.
2. The operator and all maintenance personnel shall be thoroughly familiar with the location, use, and care of the fire extinguisher(s) provided.

ACCIDENTS

If this crane becomes involved in a property damage and/or personal injury accident, immediately contact your Manitowoc dealer or the Product Safety and Reliability Department at the following address:

Manitowoc Cranes

2401 So. 30th St.
Manitowoc, WI 54220

Phone: 920-684-6621

Provide a complete description of the accident, including the crane model and serial number. Accident reporting forms can be found at www.manitowoc.com.

The crane must not be returned to service until it is thoroughly inspected for any evidence of damage. All

damaged parts must be repaired or replaced as authorized by Manitowoc.

SAFE MAINTENANCE



WARNING

Importance of safe maintenance cannot be over emphasized. Carelessness and neglect on part of maintenance personnel can result in their death or injury and costly damage to the crane or property.

Safety information in this publication is intended only as a guide to assist qualified maintenance personnel in safe maintenance. Manitowoc cannot foresee all hazards that will arise in field; therefore, **safety remains responsibility of maintenance personnel and crane owner.**

Maintenance Instructions

To ensure safe and proper operation of Manitowoc cranes, they must be maintained according to the instructions contained in this manual and in the Service Manual provided with the crane.

Crane maintenance and repair must be performed by qualified personnel. These personnel shall **read Operator Manual and Service Manual before attempting any maintenance procedure.** If there is any question regarding maintenance procedures or specifications, contact your Manitowoc dealer for assistance.

Qualified person is defined as one who by reason of training and experience is thoroughly familiar with the crane's operation and required maintenance as well as the hazards involved in performing these tasks.

Training and qualification of maintenance and repair personnel are crane owner's responsibility.

Safe Maintenance Practices

1. Perform the following steps (as applicable) before starting a maintenance procedure:
 - a. Park the crane where it will not interfere with other equipment or operations.
 - b. Lower all loads to the ground or otherwise secure them against movement.
 - c. Lower the boom onto blocking at ground level, if possible, or otherwise secure the boom against dropping.
 - d. Move all controls to off and secure all functions against movement by applying or engaging all brakes, pawls, or other locking devices.
- e. Stop the engine and render the starting means inoperative.
- f. Place a warning sign at the start controls alerting other personnel that the crane is being serviced and the engine must not be started. **Do not remove sign until it is safe to return the crane to service.**
2. Do not attempt to maintain or repair any part of the crane while the engine is running, unless absolutely necessary.

If the engine must be run, keep your clothing and all parts of your body away from moving parts. **Maintain constant verbal communication between person at controls and person performing maintenance or repair procedure.**
3. Wear clothing that is relatively tight and belted.
4. Wear appropriate eye protection and approved hard hat.
5. Never climb onto or off a moving crane. **Climb onto and off the crane only when it is parked and only with operator's permission.**

Use both hands and handrails, steps and ladders provided to climb onto and off the crane.

Lift tools and other equipment which cannot be carried in pockets or tool belts onto and off the crane with hand lines or hoists.
6. The boom and gantry are not intended as ladders. Do not attempt to climb lattice work of the boom or gantry to get to maintenance points. If the boom or gantry is not equipped with an approved ladder, lower them before performing maintenance or repair procedures.
7. Do not remove cylinders until the working unit has been securely restrained against movement.
8. Pinch points are impossible to eliminate; watch for them closely.
9. Pressurized air, coolant, and hydraulic oil can cause serious injury. Make sure all air, coolant, and hydraulic lines, fittings, and components are tight and serviceable.

Do not use your hands to check for air, coolant or hydraulic oil leaks:

 - Use a soap and water solution to check for air leaks (apply to fittings and lines and watch for bubbles).
 - Use a piece of cardboard or wood to check for coolant and hydraulic oil leaks.
10. Relieve pressure before disconnecting air, coolant, and hydraulic lines and fittings.
11. Do not remove the radiator cap while the coolant is hot or under pressure. Stop the engine, wait until the pressure drops and the coolant cools, then slowly remove the cap.

12. Avoid battery explosion: do not smoke while performing battery maintenance or short across battery terminals to check its charge.
13. Read the safety information in the battery manufacturer's instructions before attempting to charge a battery.
14. Avoid battery acid contact with skin and eyes. If contact occurs, flush the area with water and immediately consult a doctor.
15. Stop the engine before refueling the crane.
16. Do not smoke or allow open flames in refueling area.
17. Use a safety-type can with an automatic closing cap and flame arrestor for refueling.
18. Hydraulic oil can also be flammable. Do not smoke or allow open flames in the area when filling hydraulic tanks.
19. Never handle wire rope with bare hands. Always wear heavy-duty gloves to prevent being cut by broken wires.
20. Use extreme care when handling coiled pendants. Stored energy can cause the coiled pendants to uncoil quickly with considerable force.
21. When inflating tires, use a tire cage, a clip-on inflater, and an extension hose which permits standing well away from the tire.
22. Only use cleaning solvents which are non-volatile and non-flammable.
23. Do not attempt to lift heavy components by hand. Use a hoist, jacks, or blocking to lift components.
24. Use care while welding or burning on the crane. Cover all hoses and components with non-flammable shields or blankets to prevent a fire or other damage.
25. To prevent damage to crane parts (bearings, cylinders, swivels, slewing ring, computers, etc.), perform the following steps **before welding on the crane**:
 - Disconnect all cables from batteries.
 - Disconnect output cables at engine junction box.
 - Attach the ground cable from the welder directly to the part being welded and as close to the weld as possible.

Do not weld on the engine or engine mounted parts (per engine manufacturer).
26. Disconnect and lock the power supply switch before attempting to service high voltage electrical components and before entering tight areas (such as carbody openings) containing high voltage components.
27. When assembling and disassembling booms, jibs, or masts on the ground (with or without support of boom rigging pendants or straps), securely block each section to provide adequate support and alignment.

Do not go under boom, jib, or mast sections while connecting bolts or pins are being removed.
28. Unless authorized in writing by Manitowoc, do not alter the crane in any way that affects the crane's performance (including welding, cutting, or burning of structural members or changing pressures and flows of air/hydraulic components). Doing so will invalidate all warranties and Capacity Charts and make the crane owner/user liable for any resultant accidents.
29. **Keep crane clean.** Accumulations of dirt, grease, oil, rags, paper, and other waste will not only interfere with safe operation and maintenance but also create a fire hazard.
30. Store tools, oil cans, spare parts, and other necessary equipment in tool boxes. Do not allow these items to lie around loose in the operator cab or on walkways and stairs.
31. Do not store flammable materials on the crane.
32. Do not return the crane to service at completion of maintenance or repair procedures until all guards and covers have been reinstalled, trapped air has been bled from hydraulic systems, safety devices have been reactivated, and all maintenance equipment has been removed.
33. Perform a function check to ensure proper operation at the completion of maintenance or repair.

ENVIRONMENTAL PROTECTION

Dispose of waste properly! Improperly disposing of waste can threaten the environment.

Potentially harmful waste used in Manitowoc cranes includes — but is not limited to — oil, fuel, grease, coolant, air conditioning refrigerant, filters, batteries, and cloths which have come into contact with these environmentally harmful substances.

Handle and dispose of waste according to local, state, and federal environmental regulations.

When filling and draining crane components: do not pour waste fluids onto the ground, down any drain, or into any source of water.

- Always drain waste fluids into leak proof containers that are clearly marked with what they contain.
- Always fill or add fluids with a funnel or a filling pump.
- Immediately wipe up any spills.

**View A
WRONG – DANGEROUS!**

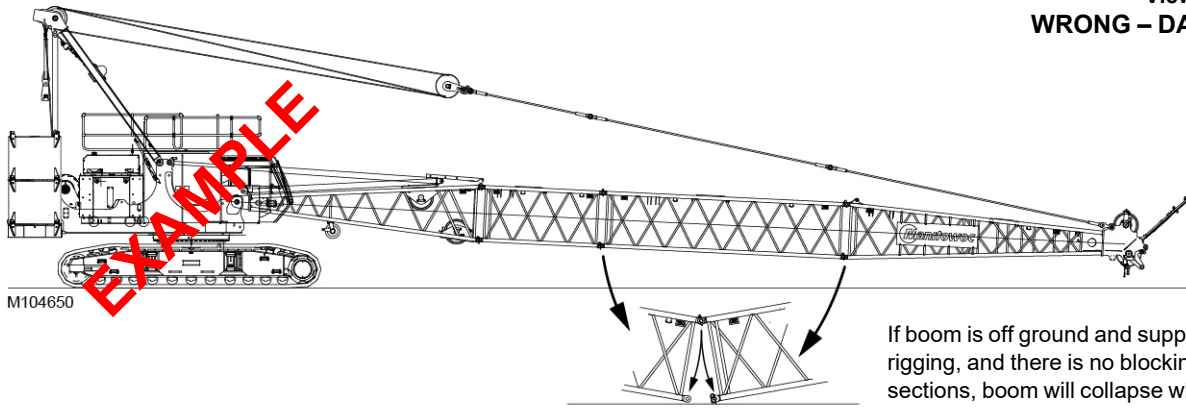

**View B
WRONG – DANGEROUS!**

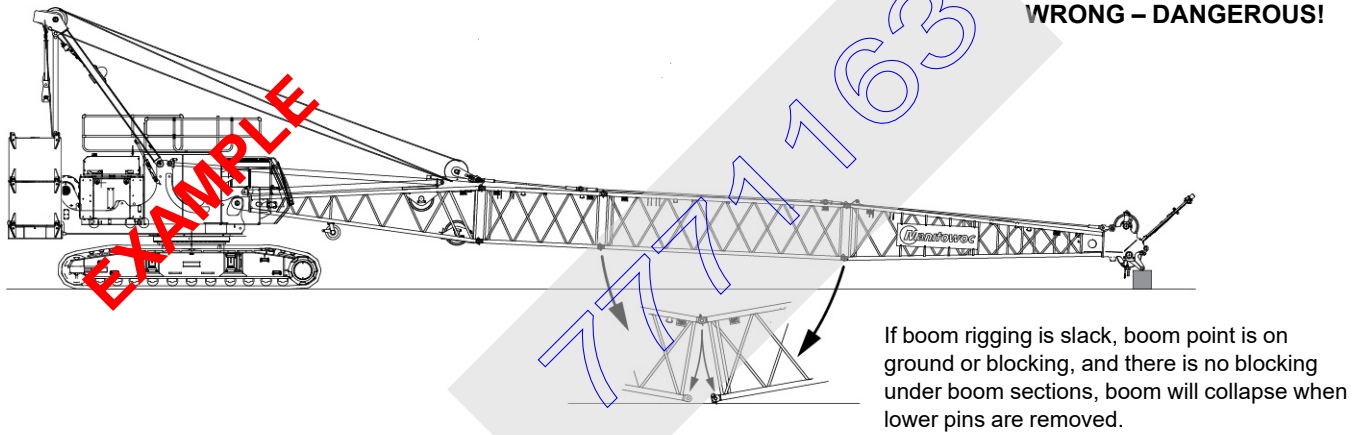

**View C
RIGHT – SAFE**

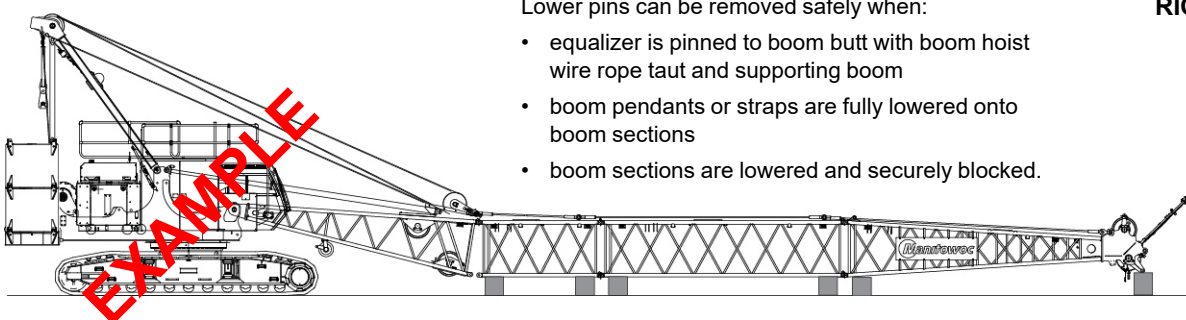

Lower pins can be removed safely when:

- equalizer is pinned to boom butt with boom hoist wire rope taut and supporting boom
- boom pendants or straps are fully lowered onto boom sections
- boom sections are lowered and securely blocked.

Figure 2-3. Boom Disassembly

BOOM DISASSEMBLY SAFETY

NOTE The term “boom” used in the following instructions applies to all lattice attachments (fixed jib, luffing jib, mast, etc.).



DANGER! **Collapsing Boom Hazard!**

Prevent death or serious injury when disassembling boom sections — read and adhere to the following instructions.

Safe handling of lattice booms during disassembly is a primary concern for preventing serious or fatal injuries. A boom can collapse during disassembly if workers fail to observe safe working practices.

Accidents during boom disassembly usually result from one of three primary causes:

- Workers are not familiar with equipment or are not properly trained.
- Disassembly area is not suitable.
- Safe procedures are overlooked because not enough time is allocated for the task.

General

Safety decals (Figure 2-4) are placed near the connectors on the boom sections as shown on the Boom Disassembly Decal Drawing at the end of this section.

Workers involved with boom disassembly shall be trained and experienced in the operation and disassembly of construction cranes. Everyone shall read and understand these instructions, the information in the Boom Assembly Drawing, and the instructions in Section 4 before beginning disassembly. Anyone who has a question should ask for an explanation. **One worker who does not fully understand or fails to follow correct procedures can endanger other workers.**

Location

Select a suitable location for boom disassembly. It must be firm, level, and free of obstructions. It should have enough open space to accommodate the crane, the length of boom, and – if required – movement of an assist crane or other equipment. If possible, secure the area to keep unauthorized personnel and vehicles away.

Pin Removal

When removing pins from boom sections, stand clear of pins being removed. Even though the boom is resting on

blocking, individual pin connections may still be under load. Pins can be ejected forcefully if the boom has any pressure on it or if the boom is not supported properly.

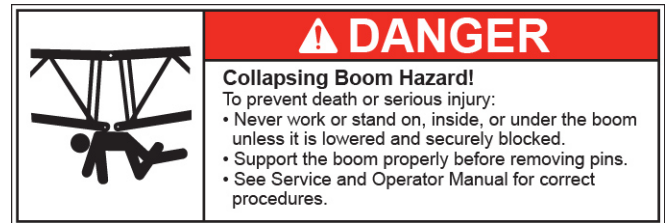

M101904

Figure 2-4. Safety Decal

Disassembly Precaution

Always block boom sections so they are securely supported and cannot shift or move suddenly when pins are removed. If there is any doubt about a boom disassembly procedure, **block tightly under boom sections before removing any pin.**



DANGER **Collapsing Boom Hazard!**

Boom can collapse or jerk when pins are removed. To avoid death or serious injury:

- Do not remove bottom connecting pins from any boom section when boom is supported by pendants as shown in Figure 2-3, View A.
- Do not remove pendant connecting pins until pendants are fully lowered onto boom sections as shown in Figure 2-3, View C.
- Do not remove bottom connecting pins from any boom section when boom point is resting on ground or blocking and boom rigging is slack as shown in Figure 2-3, View B.
- Never work or stand inside boom unless it is lowered and securely blocked as shown in Figure 2-3, View C.
- Do not stand or walk on top of the boom.



DANGER **Falling Boom Hazard!**

Crane can tip or the boom can collapse if excess boom is cantilevered. Never cantilever more boom than allowed in rigging drawing or capacity chart.

SPECIAL APPLICATION/SERVICE

Special Application/Service is defined as anything other than normal lifting activities or normal lifting operation.

As identified in ASME B30.5, cranes are sometimes used for service other than lifting service and/or special lifting operations. In such cases Manitowoc or a qualified person shall review the service to be performed and jobsite conditions prior to operation. If appropriate, Manitowoc or a qualified person shall determine and establish a reduction in rated capacity, operating limitations, maintenance, testing and inspection requirements based on the job site conditions/limitations.

Because Manitowoc is not aware of all job site conditions/limitations we cannot provide further guidance until the intended service is understood, and a review of the conditions/limitations is complete.

Manitowoc cannot foresee all hazards that will arise in the field related to the special applications/services below; therefore, safety remains the responsibility of the qualified lifting personnel involved in the crane operations and owners.

Additional resources, training and experience may exist in the crane industry to provide guidance of risk assessments and hazard avoidance regarding special applications/service.

PERSONNEL HANDLING POLICY

In 1998, the American Society of Mechanical Engineers issued a new American National Standard entitled, Personnel Lifting Systems, ASME B30.23-1998. This standard provides, ***“lifting and lowering of personnel using ASME B30 Standard hoisting equipment shall be undertaken only in circumstances when it is not possible to accomplish the task by less hazardous means. Unless all of the applicable requirements of this volume are met, the lifting or lowering of personnel using ASME B30 Standard equipment is prohibited.”***

The ASME Standards recognize that mobile and locomotive cranes are primarily designed and intended for handling materials and not personnel. The ASME Standards have a retrofit statement that applies to existing cranes after the standards go into effect. It is not the intent of the standards to require retrofitting of existing equipment. If an item is being modified, the performance requirement must be reviewed relative to the current standard.

This new standard is consistent with the U.S. Department of Labor, Occupational Safety and Health Administration (OSHA) regulations for Construction that state, in 29CFR1926.1431(a): ***The use of a crane or derrick to hoist employees on a personnel platform is prohibited, except when the erection, use, and dismantling of conventional means of reaching the work site, such as a***

personnel hoist, ladder, aerial lift, elevating work platform or scaffold, would be more hazardous or is not possible because of structural design or work site conditions.

Use of a Manitowoc crane to handle personnel is acceptable provided:

- The crane user shall comply with the manufacturer's specifications and limitations for lifting accessories (hooks, slings, personnel platforms, etc.).
 - The requirements of the applicable national, state and local regulations and safety codes are met.
 - A determination has been made that use of a crane to handle personnel is the least hazardous means to perform the work.
 - The crane operator shall be qualified to operate the specific type of hoisting equipment used in the personnel lift.
 - The crane operator shall remain in the crane cab at all times when personnel are off the ground.
 - The crane operator and occupants have been instructed in the recognized hazards of personnel platform lifts.
 - The crane is in proper working order.
 - Load and boom hoist drum brakes, swing brakes, and locking devices such as pawls and dogs must be engaged when the occupied personnel platform is in a stationary position.
 - The crane must be equipped with a boom angle indicator that is visible to the crane operator.
 - The crane must be equipped with boom hoist limiting device.
 - If the luffing jib is used for hoisting personnel, the crane must be equipped with a luffing jib angle indicator that is visible to the crane operator.
 - If the luffing jib is used for hoisting personnel, the crane must be equipped with a luffing hoist limiting device.
 - The crane is equipped with a positive acting device which prevents contact between the load block or overhaul ball and the boom tip (anti-two-block device).
For friction cranes, this implies the addition of spring applied brakes activated by the anti-two-block device. The load line hoist drum must have a system or device on the power train, other than the load hoist brake, which regulates the lowering rate of speed of the hoist mechanism (controlled load lowering).
- Free fall of the hoist line is prohibited.***
- The Operator Manual is in the cab, readily accessible to the operator.

- The crane's load Capacity Chart is affixed inside the crane cab, readily accessible to the operator. The total weight of the loaded personnel platform and related rigging must not exceed 50 percent of the rated capacity for the radius and configuration of the crane.
- The crane is uniformly level within one percent of level grade and located on a firm footing. Some Capacity Charts require more stringent levelness criteria.

Cranes with outriggers or stabilizers must have them all extended and locked. All outriggers or stabilizers must be extended equally in accordance with the Capacity Charts and operating procedures.

- Handling personnel from a platform suspended by wire rope from a luffing jib is acceptable, but only when it is not possible to accomplish the task using a less hazardous means. The crane user and operator shall take into account hazards that may be present when using a luffing jib.
- Direct attachment of a personnel platform to a luffing jib is prohibited.
- The platform meets the requirements as prescribed by applicable standards and regulations.
- Applicable personal protection equipment is provided (for example, personal fall-protection system).
- For wire rope suspended platforms, the crane is equipped with a hook latch that can be closed and locked, eliminating the throat opening.
- The platform is properly attached and secure.
- Personnel platforms must not be used in winds exceeding 20 mph (9 m/s) at the hoisted platform height or in electric storms, snow, ice, sleet, or other adverse weather conditions which could affect the safety of personnel.
- Hoisting personnel within 6 m (20 ft) of a power line that is up to 350 kV or within 15 m (50 ft) of a power line that is over 350 kV is PROHIBITED, except for work covered in OSHA 29CFR1926 subpart V.

For operation outside the United States, the requirements of the applicable national, state and local regulations and safety codes must be met. This may include, in addition to the above:

- Automatic brakes such that when the equipment operating controls are released, the motions are brought to rest.
- A holding device (such as a load hold check valve) must be provided in the hydraulic or pneumatic

systems to prevent uncontrolled movement of the hoisting equipment in the case of a system failure.

Manitowoc offers upgrade packages for friction controlled models to install anti-two-block, dead man control, and automatic hoist system control requirements to satisfy other codes and standards.

Manitowoc recommends that cranes be properly maintained, regularly inspected, and repaired as necessary. All safety signs must be in place and legible. We also urge Manitowoc crane owners to upgrade their cranes with rated capacity indicator/limiter systems for all lifting operations.

In 2016, **The International Crane Stakeholder Assembly** published a guidance document titled *Lifting of Persons with Mobile Cranes*. This document may assist crane owners and lifting personnel in the risk assessment of personnel handling.

If you have any questions about this subject or other product safety matters relating to the operation and use of a Manitowoc crane, please contact your Manitowoc dealer or the Product Safety and Reliability Department at the following address:

Manitowoc Cranes
2401 So. 30th St.
Manitowoc, WI 54220
Phone: 920-684-6621

PEDESTAL/BARGE MOUNTED CRANES

WARNING **Overload Hazard!**

A pedestal mounted crane will not tip to indicate to the operator that the crane's capacity has been exceeded. When the capacity of a pedestal mounted crane is exceeded, the hook rollers or other structural components may break, before the load lines fail, causing the crane to separate from the pedestal.

For this reason, great care must be taken to operate a pedestal mounted crane within its rated capacity.

Careful planning is required before a crane can be operated on a barge. The crane user shall verify that the barge is capable of limiting crane list and/or dynamics to the maximum allowable specified in the Capacity Charts. If the specified crane list and/or dynamic conditions are exceeded, the crane's capacity may be exceeded; the hook rollers or other structural components may break, causing the crane to separate from the pedestal.

! WARNING

The crane owner/user shall verify that the method used to fasten or restrain the crane to the foundation, the barge, the ship or the floating platform is strong enough, under all operating conditions, to prevent the crane from breaking off the foundation or moving on the barge.

Manitowoc does not permit use of a lattice boom truck crane on a barge, a ship, or a floating platform.

Pedestal Mounted Crane

Also see ASME publication B30.8-2015, Floating Cranes and Derricks.

Definition

A pedestal mounted crane is a crane which is securely fastened to a foundation, barge, ship, or floating platform so the crane is restrained from tipping.

Examples

1. Crane rotating bed mounted on a turret (pedestal) which is securely fastened to the foundation ([Figure 2-5](#)).

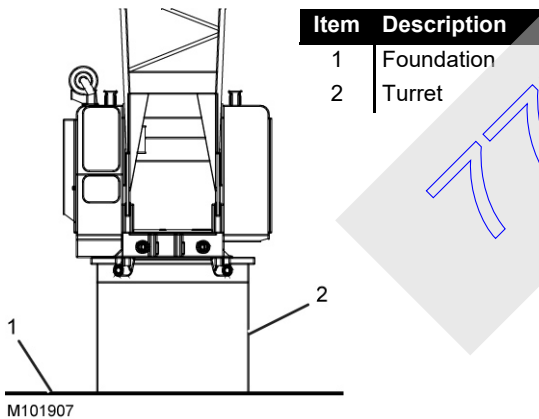

Figure 2-5. Turret-Mounted Crane

2. Crane rotating bed mounted on a carbody (crawlers removed) which is securely fastened to the foundation ([Figure 2-6](#)).

NOTE If the carbody will be bolted to the foundation, contact your Manitowoc dealer for the recommended bolt pattern and for the type and quantity of bolts to be used.

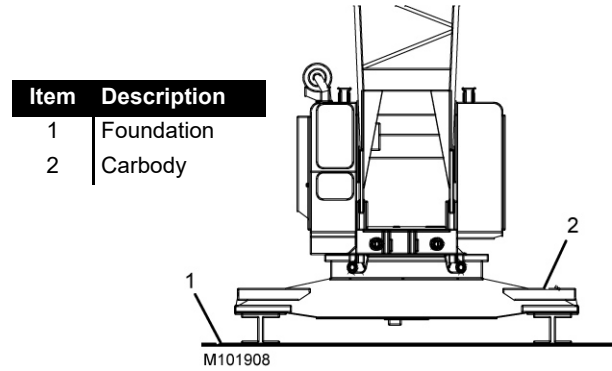

Figure 2-6. Carbody-Mounted Crane

Barge Mounted Crane

Definition

A barge mounted crane is a crane that is anchored or restrained in a work area of the barge, ship, or floating platform and is subjected to tipping forces.

Examples

NOTE The foundation is the deck of the barge, ship, or floating platform.

1. Crawler-mounted crane with the carbody anchored with tie-downs to the foundation ([Figure 2-7](#)).

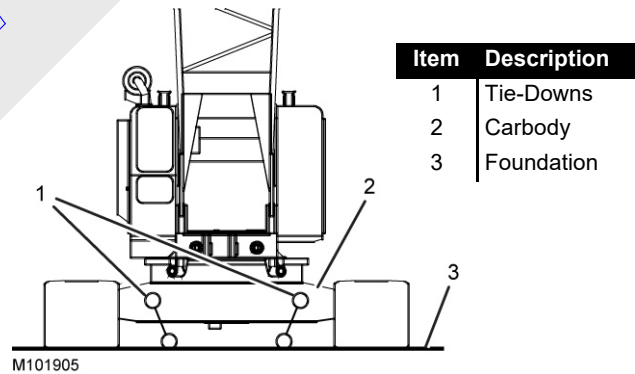

Figure 2-7. Crawler-Mounted Crane

2. Crawler-mounted crane working on a timbered area of the barge, ship, or floating platform with the crawlers restrained by curbing and end stops ([Figure 2-8](#)). When not working, the crane carbody is anchored with tie-downs to the foundation. **Traveling with load is not permitted.**

NOTE Manitowoc does not permit traveling on a barge deck with load.

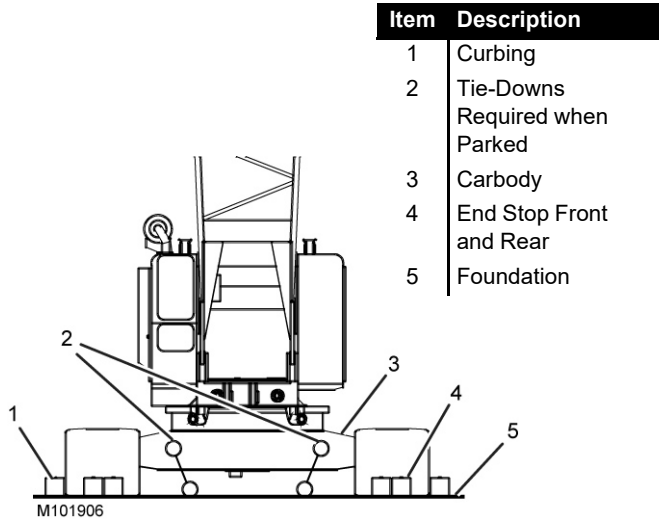

Figure 2-8. Crawler-Mounted Crane

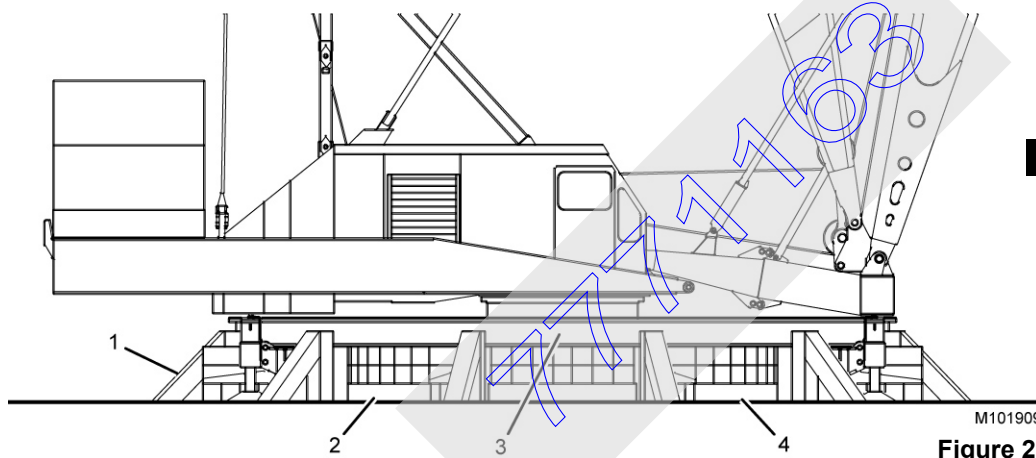
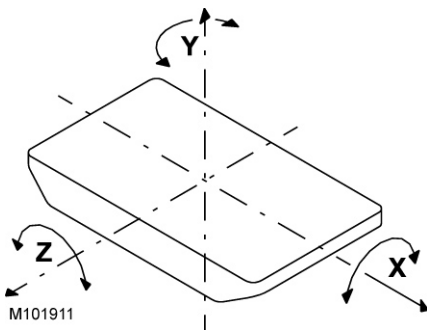

Figure 2-9. RINGER-Mounted-Crane



AXIS		TRANSITIONAL		ROTATIONAL	
SYMBOL	NAME	STATIC	DYNAMIC	STATIC	DYNAMIC
X	Longitudinal		Surge	Heel List	Roll
Y	Vertical		Heave		Yaw
Z	Lateral		Sway	Trim	Pitch

Figure 2-10. Barge Dynamics

3. RINGER® (crawler mounted, carbody mounted) supported on blocking, screw jacks, or steel pedestals which are braced and fastened to the foundation in such a manner as to prevent movement (Figure 2-9).

NOTE RINGERS must be equipped with hook rollers on the boom carrier and the counterweight carrier.

4. RINGER (platform mounted) which has the ring braced and fastened directly to the foundation in such a manner as to prevent movement.

Capacity Charts for Barge Mounted Crane

Manitowoc provides two types of Capacity Charts for a crane mounted on a barge or other supporting structure under static conditions.

1. A Capacity Chart based on tipping when the crane is anchored only to prevent shifting.
2. A Capacity Chart based on structural competence when the crane is securely fastened for use as a pedestal mounted crane.

NOTE Unless otherwise specified in a machine list Capacity Chart, a 0 degree machine list Capacity Chart rating applies to machine list **not to exceed 1/2 degree**. All other machine list ratings – 1°, 2°, and 3° – must NOT be exceeded.

Shock Loading Caused by Barge Dynamics

Shock loads to the crane can be experienced when the barge is subjected to up and down movement of wave action (referred to as DYNAMICS). [Figure 2-10](#) illustrates the dynamic conditions of the barge which influence crane capacity.

CAUTION

Structural Damage Hazard!

If the crane's boom or structure is shock loaded during operation, or there is any indication of shock loading, all structural components of the crane must be inspected to detect cracks and other damage. Nondestructive test equipment, such as magnetic particle or ultrasonic procedures, is recommended for this inspection.

NOTE Manitowoc does not recommend crane operation under dynamic conditions.

Operation on Barge

Machine list and/or dynamics will be experienced when a crane is operated on a barge, ship, or floating platform. Both of these conditions reduce the crane's capacity and each must be taken into account for safe operation on a barge, ship, or floating platform.



WARNING

Tipping Crane Hazard!

Tie-downs which only prevent the crane from shifting as in barge, ship or floating platform mounting, may not provide adequate support when using a Capacity Chart for pedestal mounting. Before operating a crane on a barge, a ship or a floating platform, the crane user shall verify that correct the Capacity Chart is being used — pedestal mounted, barge mounted, 0°, 1°, 2° or 3° list or dynamic Capacity Chart.

Failing to use the correct Capacity Chart can result in an accident.

Barge Mount Definitions

1. Machine List, as defined by Manitowoc, is the crane's out-of-level condition — from side-to-side — as measured by the angle between horizontal and a line drawn through the centerline of the crane's boom hinge pins ([Figure 2-11](#)). This out-of-level condition creates side load and affects the crane's lifting capacity.

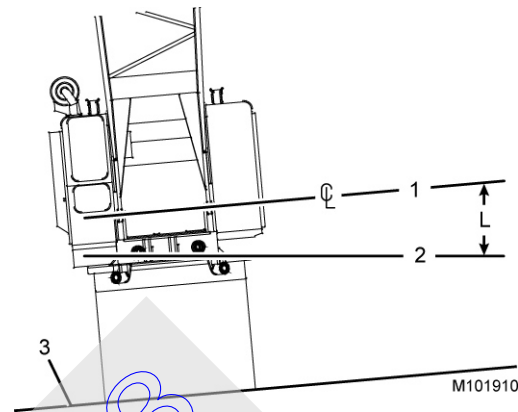

Item	Description
1	Centerline through Boom Hinge Pins
2	Horizontal
3	Barge Deck
	Degrees of Machine List (Maximum allowable is specified in Capacity Chart)

Figure 2-11. Machine List

2. Barge List (also referred to as heel or trim) causes swing out of the load and may produce side load. When Manitowoc provides a Capacity Chart showing capacities for a 2 degree machine list for example, we are referring to the maximum allowable lifting capacity for the crane when experiencing an out-of-level condition (side-to-side) of 2 degrees as measured by angle between horizontal and a line drawn through centerline of the crane's boom hinge pins.

Unless otherwise specified in the Capacity Chart, barge list (heel or trim) must not exceed the machine list degrees given in the Capacity Chart.

3. Barge List and Machine List are not the same. As the crane rotates on a barge, barge list (as defined above) will change. The worst machine list condition generally occurs when the crane swings over the corner of the barge, producing maximum side load.

Inspection of Barge-Mounted Crane

To aid in preventing harmful and damaging failure as previously indicated, regular inspection for signs of overloading in the following load bearing components is

required. Correct each defect found before placing the crane into service.

- Boom
- Counterweight
- Backhitch
- Rotating Bed
- Wire Rope
- Pendants and Straps
- Hook and House Rollers

When equipped with hook rollers, it is recommended that each hook roller assembly be inspected daily for any sign of overloading, to include:

- Deformation of roller path
- Proper hook roller adjustment
- Deformation or cracks in hook roller hanger
- Bent hook roller shaft
- Damaged bearings

Transporting Crane on Barge

If it is necessary to transport the crane on a barge, ship, or floating platform when dynamic conditions will be experienced, the boom must be lowered onto a cradle (or other support) and the crane's boom, rotating bed, and lowerworks must be secured against movement. If the crane is equipped with a mast, the mast must be securely tied down with guylines. Failing to take these steps can result in shock load or side load damage to the boom and mast.

PILE DRIVING AND EXTRACTING

Introduction

By operating within the following guidelines, pile driving is an approved application for Manitowoc brand mobile crawler cranes. Because pile driving and extracting presents many variables and unknowns, Manitowoc crane owners shall exercise discretion when considering the use of a crane for this application.

It is not our intention to recommend specific types or makes of pile driving and extracting equipment but rather to advise crane owners of our operational requirements to help avoid pile driving and extracting from having any detrimental effect on the crane and invalidating the new machine warranty. The following are the operating requirements that must be used during pile driving and extracting with a Manitowoc crawler crane. These notes are in addition to any guidelines published on the crane's capacity charts.

Operation of Pile Driving and Extracting Equipment

1. The combined weight of the drive or extractor, piling, leads, attachments, etc., must not exceed the published load chart values. A qualified person shall determine if additional capacity reductions are necessary.
2. The pile driver or pile extractor must be kept clear of the boom top at all times.
3. The crane operator shall ensure that the crane is not subject to impact loading or vibration being induced into the boom and crane structure by meeting the rate of descent of the driver and piling.
4. Pile driving or extracting must be restricted to the boom. A qualified person shall determine an appropriate configuration.
5. Pile Extraction is only permitted when using extraction devices that do not transmit vibration or shock loading into the crane. All possible precautionary measures must be taken to prevent shock loads or vibration from being imposed on crane components, either directly through the hoist cable or indirectly from ground borne vibration. Do not exceed load capacity.
6. The crane operator and other personnel associated with the pile driving and pile extraction operation shall have read and understood all safety standards applicable to crane operations as well as being thoroughly trained in the safe operation of pile driving and extracting equipment.
7. The load lines must be kept vertical at all times during pile driving and pile extraction operations.

Crane Equipment

1. Manitowoc recommends that hoist cable length be reduced to operate on the first layer for optimal spooling.
2. Crane must be assembled per applicable rigging drawing and operator manual.
3. All hoist hooks must be equipped with a positive locking latch.
4. Refer to the specific hook block or headache ball manufacturer website for additional guidelines on usage in pile driving applications.

Crane Inspection

1. In addition to the crane's frequent and periodic inspections, dated daily records must be maintained showing inspections were performed on the crane during the time it was used for pile driving or extraction.
2. The "40 Hours of Operation or Weekly" boom related inspection intervals published in the crane's *Inspection*

and *Maintenance Checklist* must be increased to 8 hour or daily intervals for the duration of pile driving operations.

3. The hoist cable must be inspected daily to ensure no abrasion or wear is occurring.

In 2014, **FEM**, a member of **The International Crane Stakeholder Assembly** published a guidance document titled *Using Mobile Cranes for Pile Driving/Extraction*. Additionally, ASSE A 10.19 Safety Requirements for Pile Installation and Extraction Operations may assist crane owners and lifting personnel in the risk assessment related to pile driving/extraction.

ELECTROCUTION HAZARD DEVICES

The use of insulated links, insulated boom cages/guards, or proximity warning devices does not assure that electrical contact will not occur. Therefore, Manitowoc does not endorse their use. When insulated links, insulated boom cages/guards, or proximity warning devices are installed on the crane as required by Regulations, Industry Codes, or company policies, the crane owner is responsible for ensuring that:

- a. The device manufacturer is contacted and provides instructions for storage, inspection, maintenance, and use of the devices.
- b. The device manufacturer provides all limitations and restrictions of the device.
- c. The documentation provided by the device manufacturer is maintained on the crane and available to the crane operator at all times.

Further, when insulated links, insulated boom cages/guards, or proximity warning devices are installed on the crane, a pre-operational meeting is to be held and a review of the instructions, limitations and restrictions related to the device(s) will be communicated to all personnel that are to work on or around the crane.

Even if the crane is equipped with these devices, failure to follow the rules, limitations and precautions outlined in this manual and provided by the device manufacturer at all times may result in serious injury or death.

Do not depend on grounding. Grounding of a crane affords little or no protection from electrical hazards. The effectiveness of grounding is limited by the size of the conductor (wire) used, the condition of the ground, the magnitude of the voltage/current present, and numerous other factors.

MULTIPLE LOAD LINE OPERATION

Multiple load line operation is becoming common practice for applications like panel tilt-up, pile tilt-up, pile driving, rolling fabricated sections, etc. The multiple load lines may be on a

common shaft (each with different parts of line) or on multiple shafts (lower boom point and upper point, boom point and fixed jib point, etc).

Manitowoc authorizes multiple load line operation for those applications requiring it, provided the following steps are performed:

1. The qualified lift planner and crane operator shall read and become thoroughly familiar with the appropriate Capacity Charts and Wire Rope Specification Charts.
2. The lift planner and the crane operator shall make sure the total load does not exceed the rated capacity given in the Capacity Chart and Wire Rope Specification Chart for given boom point or jib point, whichever is less.

EXAMPLE: If one load line is lifting from the jib point, the proper jib chart applies.

3. The crane must be thoroughly inspected by a qualified person prior to setup.
4. The crane must be thoroughly inspected for load line interference caused by routing and reeving of multiple load lines. If interference is found, it must be eliminated.
5. For cranes produced before 2003, Rated Capacity Indicators/Limiters were not required by ASME B30.5 for non-personnel lifting.

To aid the operator in staying within the crane's Capacity Chart with the total applied load, Manitowoc recommends that its cranes be equipped with Rated Capacity Indicators/Limiters to monitor the load on each load line.

Operator is still responsible for knowing load and radius whether or not the crane is equipped with load indicator(s).

6. Manitowoc recommends that each load line be equipped with an anti two-block device.
7. Manitowoc's Capacity Charts are based on freely suspended loads. To prevent side load damage to the boom, jib, and sheaves:
 - The load lines must hang as close to vertical as possible to minimize side and forward loads.
 - The load must remain centered on the boom and jib point shafts unless special lift approval is granted by Manitowoc.
 - The load lines should be located over the load's center of gravity as it is supported on a trailer, a barge, or the ground.
8. To minimize the angle of the load transmitted into the boom and/or jib, the distance between the load points and the hook points must be a minimum of three times the horizontal distance between the hook point on the load being lifted.

9. The crane operator shall be familiar with the operational characteristic of the crane as it relates to multiple drum operation (simultaneous operation, same or opposite direction, or individual operation).
10. When using tandem drums, the maximum operating layers may be limited depending on whether the crane was initially designed for tandem drum operation or not.
11. Load shift when lifting with two hooks may be more unpredictable than typical one hook lifting.

MULTIPLE CRANE LIFTS

Operate with extreme caution when using more than one crane to lift the same load. Any lift that requires more than one crane to lift the same load must be precisely planned and coordinated by a qualified person due to new and different hazards.

The following additional precautions must be taken if it is necessary for more than one crane to lift the load:

- a. Secure the services of a qualified person to analyze and plan the lift.
- b. Verify proper controls are in place to prevent overload such as the necessity to reduce crane ratings, load position, boom position, ground support, and speed of movements. These controls must be in accordance with the qualified person's

decision and all other requirements identified in the operator manual.

- c. Ensure the lift director coordinates and instructs all personnel involved in the lift plan, to include but limited to, proper rigging and positioning of the load and all movements to be made prior to beginning the lift.
- d. Make sure all signals are coordinated through the lift director.
- e. A qualified person must direct the lift.
- f. Maintain communication between all parties throughout the entire lift. If possible, provide approved radio equipment for voice communication between all parties engaged in the lift.
- g. Ensure the load lines are directly over the attach points to avoid side loading, forward loading, and transfer of loading from one crane to the other.

In 2016, **The International Crane Stakeholder Assembly** published a guidance document titled *Lifting A Load With Several Mobile Cranes (Multiple Crane or Tandem Lifting)*. This document may assist crane owners and lifting personnel in the risk assessment of multiple crane lifts.

THIS PAGE INTENTIONALLY LEFT BLANK

777163

SECTION 3

OPERATING CONTROLS AND PROCEDURES

TABLE OF CONTENTS

Standard Hand Signals for Controlling Crane Operations	3-2
Symbol Identification	3-4
Front Window Operation	3-8
Closing Window	3-8
Opening Window for Ventilation	3-8
Opening Window for Emergency Exit	3-8
Operating Controls	3-8
Controls Identification and Function	3-11
A – Power Controls	3-11
A1. Engine Ignition Switch	3-11
B – Engine Controls	3-11
B1. Engine Warning/Diagnostic Lights	3-11
B2. Ether Starting Aid Switch (for 6CTA8.3-C260 or QSL 340 engine only)	3-11
B3. Engine Hand Throttle	3-11
B4. Engine Foot Throttle	3-11
B5. Engine Clutch Pedal	3-11
B6. Emergency Engine Stop Switch	3-11
B7. Battery Disconnect Switch	3-12
C – Accessory Controls	3-12
C1. Dome Light Switch	3-12
C2. Panel Light Switch	3-12
C3. Heater/Air Conditioner Fan Switch	3-12
C4. Horn Switch	3-12
C5. Air Conditioner Temperature Selector	3-12
C6. Air Conditioner/Heater Switch	3-12
C7. Front Windshield Wiper Switch	3-12
C8. Overhead Windshield Wiper Switch	3-12
C9. Defroster Fan	3-12
C10. Tinted Visor	3-12
C11. Machinery Heaters	3-12
C12. Windshield Washer Switch	3-13
D – Indicators	3-13
D1. Digital Display and Selector Switch	3-13
D2. Operating Limit Alert	3-13
D3. System Fault Alert	3-13
D4. Rotation Indicators	3-13
D5. Level	3-13
D6. Mirrors	3-13
D7. Rated Capacity Indicator/Limiter Console	3-13
D8. Engine Hourmeter	3-13
D9. Boom Angle Indicator	3-13
E – Gauges	3-14
E1. Fuel Level Gauge	3-14
E2. Engine Water Temperature Gauge	3-14
E3. Engine Oil Pressure Gauge	3-14
E4. Battery Voltage Gauge	3-14
E5. Hydraulic Oil Temperature Gauge	3-14
F – Special Controls/Indicators	3-17
F1. Limit Bypass Switch	3-17
F2. Crane Mode Selector	3-17
F3. Front Drum Free Fall Light	3-18

F4. Rear Drum Free Fall Light	3-18
F5. Seat Switch	3-18
F6. Jib Up Limit Bypass Switch	3-18
G – Boom Hoist Controls	3-18
G1. Boom Hoist Handle	3-18
G2. Boom Hoist Park Switch	3-18
G3. Boom Cylinder Hold Switch	3-19
H – Load Drum Controls	3-19
Full-Power Operation (Free Fall Off)	3-19
Free Fall Operation (if equipped)	3-19
H1. Front Drum Handle	3-19
H2. Rear Drum or Luffing Jib Handle	3-19
H3. Auxiliary Drum Handle	3-19
H4. Front Drum Park Switch	3-20
H5. Rear Drum Park Switch	3-20
H6. Auxiliary Drum Park Switch	3-20
H7. Front Drum Pawl Switch	3-20
H8. Rear Drum Pawl Switch	3-20
H9. Auxiliary Drum Pawl Switch	3-20
H10. Front Drum Working Brake Pedal	3-21
H11. Rear Drum Working Brake Pedal	3-21
J – Swing Controls	3-21
J1. Swing Handle	3-21
J2. Swing Lock Switch	3-21
J3. Swing Brake Switch	3-21
J4. Swing Holding Brake Switch	3-21
K – Travel Controls	3-22
K1. Right Crawler Handle	3-22
K2. Left Crawler Handle	3-22
K3. Travel Detent Selector	3-22
K4. Travel Park Switch	3-22
K5. Right Crawler Pedal	3-22
K6. Left Crawler Pedal	3-22
K7. Travel Speed Selector	3-22
Remote Controls	3-22
Limit Devices	3-23
Counterweight Max Up Limit	3-23
Boom Maximum Up Limit	3-23
Boom Maximum Down Limit (if equipped)	3-23
Block Up Limit	3-23
Luffing Jib Max Up Limit	3-23
Luffing Jib Max Up 1 Limit	3-24
Luffing Jib Max Up 2 Limit	3-24
Luffing Jib Max Down Limit	3-24
Luffing Jib Max Down 1 Limit	3-24
Luffing Jib Max Down 2 Limit	3-24
Maximum Bail Limit	3-24
Minimum Bail Limit	3-25
Load Moment Limit	3-25
Seat Controls	3-26
Preparing Crane For Operation	3-27
Operation	3-27
Engine Start-up	3-27
Engine Diagnostics	3-29
Onboard Diagnostics	3-29
Engine Off Diagnostics	3-29
Boom Hoist Operation	3-30

Boom Hoist Speed Adjustment	3-30
Luffing Hoist Operation	3-31
Swing Operation	3-32
Swing Speed/Torque Adjustment	3-32
Load Drum Operation	3-33
Liftcrane Operation — Full Power	3-33
Liftcrane Operation — Free Fall	3-33
Clamshell Operation	3-34
Travel Operation	3-35
Stopping Engine/Leaving Crane Unattended	3-37
Fuses	3-38
Fuse Location	3-38
Fuse Identification	3-38
Voltmeter Operation	3-39
Disabling and Enabling Free Fall	3-40
Disabling Free Fall	3-40
Enabling Free Fall	3-40
Remote Controls	3-43
Controls Identification and Operation	3-44
Carbody Jack Controls	3-44
Crawler Pin Controls	3-44
Counterweight Remote Control	3-44
Programmable Controller Calibration Procedures	3-45
General	3-45
Controls Calibration	3-45
Pressure Sender Calibration	3-45
Digital Display Readings	3-45
Operating Conditions	3-46
Operating Limits	3-46
System Faults	3-46
Selecting Display Language	3-46
Diagnostic Display	3-50
Drum 1, 2, and 8	3-50
BHST (Boom Hoist)	3-51
Swing	3-51
Track	3-51
A1 (Handles)	3-51
D1 and D2 (Digital Outputs and Inputs)	3-52
Swing Limiter Operation	3-57
Programming Swing Limits	3-57
Adjusting Swing Limit Switch	3-60
Hydraulic System Controls	3-62
Components Function	3-62
Hydraulic Tank	3-62
Hydraulic Pump	3-62
Directional Control Valve	3-62
Hydraulic Filter	3-62
Spotter System Dump Valve	3-62
Cylinder Operating Controls	3-62
Wind Conditions	3-64
Cold Weather Heater Package	3-65
General	3-65
Heaters	3-65
120 Volt AC Option	3-65
240 Volt AC Option	3-65
Thermostats	3-65
Turning Heaters On	3-65

Turning Heaters Off	3-65
Preparation for Cold Weather	3-68
Crane Limitations	3-68
Wire Rope	3-68
Cold Weather Starting Aid	3-68
Coolant and Oil Pan Heaters	3-68
Cooling System	3-68
Battery	3-68
Engine Oil	3-68
Fuel Oil	3-68
Gear Oil	3-68
Hydraulic Cranes	3-68
Hydraulic Oil	3-69
General	3-69

777163

SECTION 3 OPERATING CONTROLS AND PROCEDURES









THIS SECTION STARTS ON THE NEXT PAGE

777163

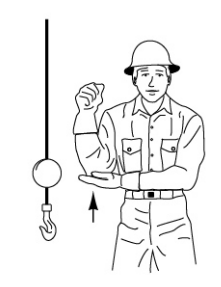
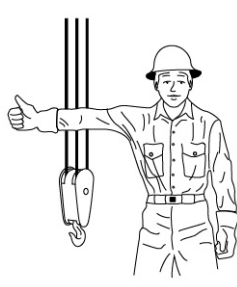
STANDARD HAND SIGNALS FOR CONTROLLING CRANE OPERATIONS

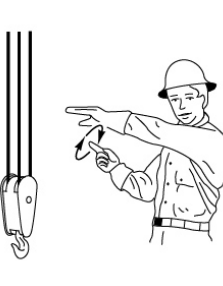
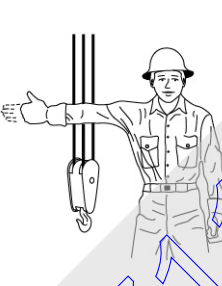
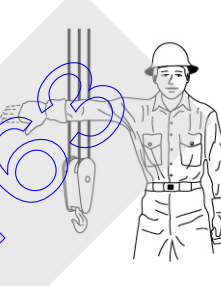
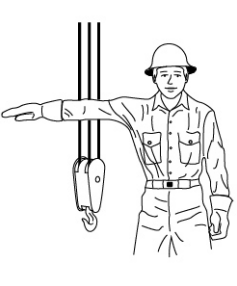
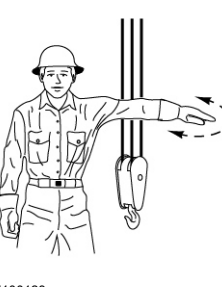
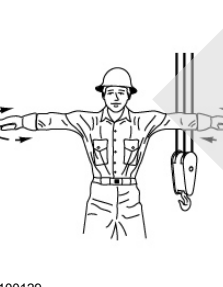
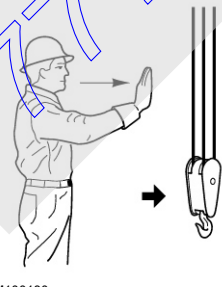
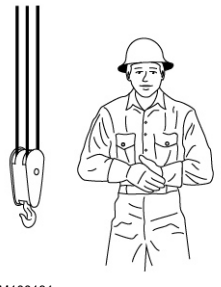
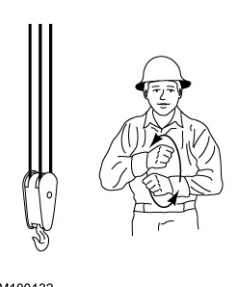
The following standard hand signals comply with ASME B30.5-2014.

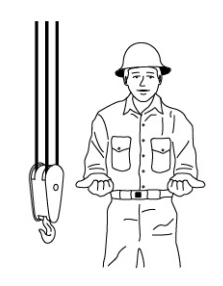
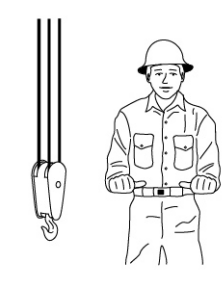
Table 3-1 Standard Hand Signals For Controlling Crane Operations

<p>1</p>  <p>M100118</p>	<p>2</p>  <p>M100119</p>	<p>3</p>  <p>M100120</p>	<p>4</p>  <p>M100121</p>	<p>5</p>  <p>M100122</p>
<p>6</p>  <p>M100123</p>	<p>7</p>  <p>M100124</p>	<p>8</p>  <p>M100125</p>	<p>9</p>  <p>M100126</p>	<p>10</p>  <p>M100127</p>
<p>11</p>  <p>M100128</p>	<p>12</p>  <p>M100129</p>	<p>13</p>  <p>M100130</p>	<p>14</p>  <p>M100131</p>	<p>15</p>  <p>M100132</p>
<p>16</p>  <p>M100133</p>	<p>17</p>  <p>M100134</p>	<p>18</p>  <p>M100135</p>	<p>19</p>  <p>M100136</p>	<p>20</p>  <p>M100137</p>

Reprinted from ASME B30.5-2014, by permission of the American Society of Mechanical Engineers. All Rights Reserved.

Item	Description
1	HOIST —With forearm vertical, forefinger pointing up, move hand in small horizontal circles.
2	LOWER —With arm extended downward, forefinger pointing down, move hand in small horizontal circles.
3	USE MAIN HOIST —Tap fist on head. Then use regular signals.
4	USE WHIPLINE (Auxiliary Hoist) —Tap elbow with one hand. Then use regular signals.
5	RAISE BOOM —Arm extended, fingers closed, thumb pointing upward.
6	LOWER BOOM —Arm extended, fingers closed, thumb pointing downward.
7	MOVE SLOWLY —Use one hand to give any motion signal and place other hand motionless in front of hand giving the motion signal (hoist slowly shown as an example).
8	RAISE BOOM & LOWER LOAD —With arm extended, thumb pointing up, flex fingers in and out as long as load movement is desired.
9	LOWER BOOM & RAISE LOAD —With arm extended, thumb pointing down, flex fingers in and out as long as load movement is desired.
10	SWING —Arm extended, point with finger in direction of swing of boom.
11	STOP —Arm extended, palm down, move arm back and forth horizontally.
12	EMERGENCY STOP —Both arms extended, palms down, move arms back and forth horizontally.
13	TRAVEL —Arm extended forward, hand open and slightly raised, make pushing motion in direction of travel.
14	DOG EVERYTHING —Clasp hands in front of body.
15	TRAVEL (Both Tracks) —Use both fists in front of body, making a circular motion about each other, indicating direction of travel forward or backward. (For Land Cranes Only).
16	TRAVEL (One Track) —Lock the track on side indicated by raised fist. Travel opposite track in direction indicated by circular motion of other fist, rotated vertically in front of body. (For Land Cranes Only).
17	EXTEND BOOM (Telescoping Booms) —Both fists in front of body with thumbs pointing outward.
18	RETRACT BOOM (Telescoping Boom) —Both fists in front of body with thumbs pointing toward each other.
19	EXTEND BOOM (Telescoping Boom) — One Hand Signal. One fist in front of chest with thumb tapping chest.
20	RETRACT BOOM (Telescoping Boom) — One hand signal. One fist in front of chest, thumb pointing outward and heel of fist tapping chest.

SYMBOL IDENTIFICATION

The following symbols are used to identify controls on this crane.













Safety Alert: Warning/Caution Operating Limit System Fault Engine Diagnostics		Data, Confirm	
Battery Voltage		Data, Select	
Boom Hold (Boom Cylinders)		Decrease/Increase	
Boom Lower		Drum	
Boom Raise		Drum, Free Fall	
Counterweights		Drum Lower - Load, Boom, Luffing Jib, or Mast	
Cylinders Extend — Retract		Drum Pawl	
		Drum Raise - Load, Boom, Luffing Jib, or Mast	

FIGURE 3-1



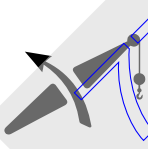
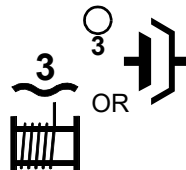

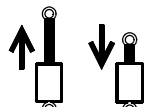











Emergency Stop		Engine Diagnostics	
Engine		Fan Blower)	
Engine, Ether Starting Aid		Fuel	
Engine Pressure		Heater	
Engine Run		Horn	
Engine Start (Current and Past Production)	 	Limit Bypass	
Engine Stop		Locked/Unlocked	
Engine Temperature		Maintenance	

FIGURE 3-1 continued





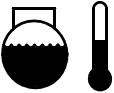









Monitor/Display		Scroll (up, down, and sideways)	
Off/Stop		Setup Mode	
On/Start		Speed — Fast	
Panel Lights (Current and Past Production)		Speed — Slow	
Park (Park On)		Swing	
Park Off		Swing Left (Current and Past Production)	
Power		Swing Lock	
Remote Control		Swing Right (Current and Past Production)	

FIGURE 3-1 continued

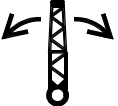

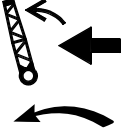

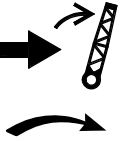

Travel	OR 	Windshield Washer	
Travel Direction Arrow indicates which crawler is operating and direction of travel with drive motors to the rear.		Windshield Wiper	
Travel Direction Arrow indicates which crawler is operating and direction of travel with drive motors to the rear.			
Travel Direction Arrow indicates which crawler is operating and direction of travel with drive motors to the rear.			
Travel Direction Arrow indicates which crawler is operating and direction of travel with drive motors to the rear.			
Travel Low Speed			

FIGURE 3-1 continued

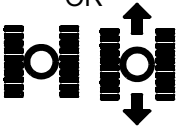
FRONT WINDOW OPERATION

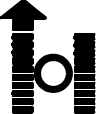
Closing Window

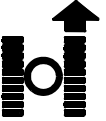
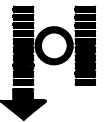
Rotate window latch handles to position shown in Figure 3-2, View A.

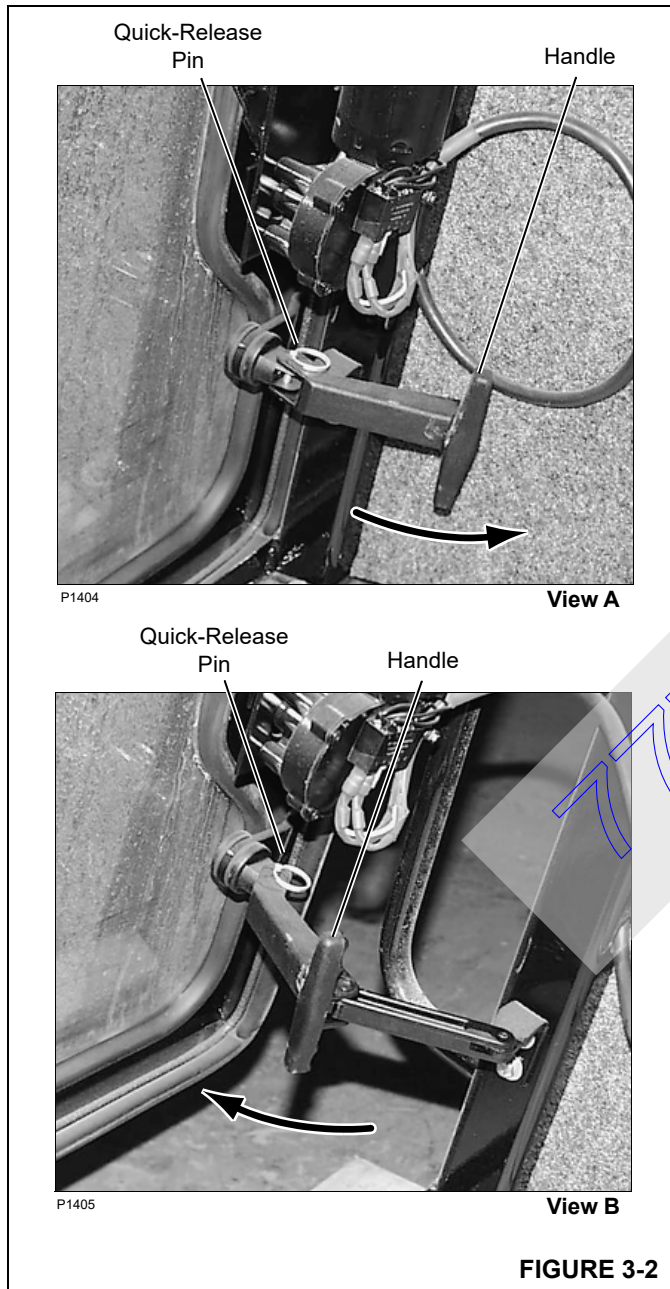

Opening Window for Ventilation

Rotate window latch handles to position shown in Figure 3-2, View B. Window can be swung open 8 in. (203 mm) for ventilation.

Opening Window for Emergency Exit

Pull out both quick-release pins Figure 3-2, View B, Window can be swung open fully to allow emergency exit from cab.

OPERATING CONTROLS

The purpose of the following instructions is to familiarize qualified operators with the location and function of standard and optional operating controls for this crane. This section also contains safety information and a description of operation for each crane function.

Depending on the options your crane is equipped with, some controls identified in this section will not apply.



WARNING

Prevent death or serious injury to personnel!

- Read and thoroughly understand instructions in this section, in Section 2, and in Capacity Chart Manual.
- Contact Factory Service Department for assistance if any operating procedure is not clearly understood.

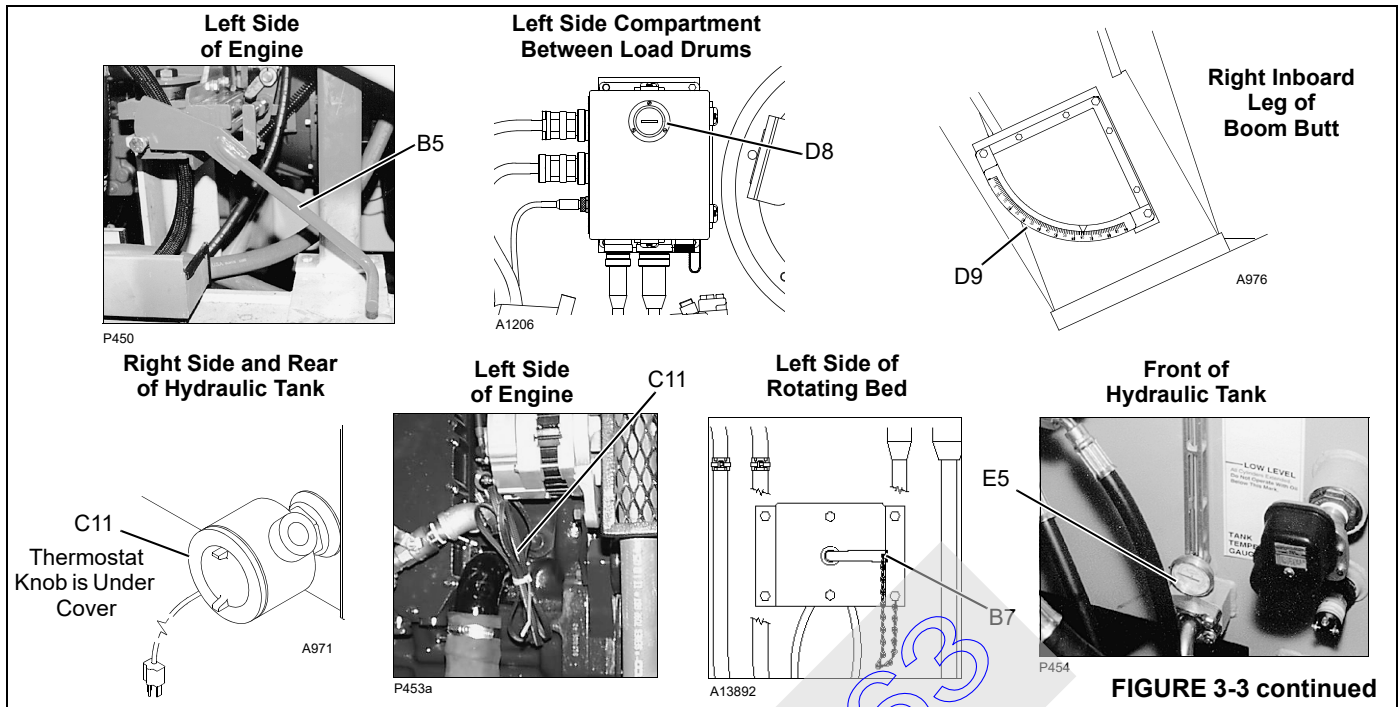

FIGURE 3-3 continued

Legend for Figure 3-3

A — Power Controls

A1. Engine Ignition Switch

B — Engine Controls

- B1. Engine Warning/Diagnostic Lights
- B2. Ether Starting Aid Switch (1)
- B3. Engine Hand Throttle
- B4. Engine Foot Throttle
- B5. Engine Clutch Pedal
- B6. Emergency Engine Stop Switch
- B7. Battery Electrical Disconnect

C — Accessory Controls

- C1. Dome Light Switch
- C2. Panel Light Switch
- C3. Heater/AC Fan Switch
- C4. Horn Switch
- C5. Air Conditioning Temperature Selector
- C6. Air Conditioner/Heater Switch
- C7. Front Windshield Wiper Switch
- C8. Overhead Windshield Wiper Switch
- C9. Defroster Fan
- C10. Tinted Visor
- C11. Machinery Heaters
- C12. Windshield Washer Switch

D — Indicators

- D1. Digital Display and Selector Switch
- D2. Operating Limit Alert
- D3. System Fault Alert
- D4. Rotation Indicators
- D5. Level
- D6. Mirrors (Interior and Exterior)
- D7. Rated Capacity Indicator/Limiter
- D8. Engine Hourmeter
- D9. Boom Angle Indicator

E — Gauges

- E1. Fuel Level Gauge
- E2. Engine Water Temperature Gauge
- E3. Engine Oil Pressure Gauge
- E4. Battery Voltage Gauge
- E5. Hydraulic Oil Temperature Gauge

F — Special Controls/Indicators

- F1. Limit Bypass Switch (2)
- F2. Crane Mode Selector
- F3. Front Drum Free Fall Light
- F4. Rear Drum Free Fall Light
- F5. Seat Switch (not shown)
- F6. Jib Up Limit Bypass Switch (1)(2)

G — Boom Hoist Controls

- G1. Boom Hoist Handle
- G2. Boom Hoist Park Switch
- G3. Boom Hold Switch

H — Load Drum Controls

- H1. Front Drum Handle
- H2. Rear Drum or Luffing Jib Handle
- H3. Auxiliary Drum Handle
- H4. Front Drum Park Switch
- H5. Rear Drum Park Switch
- H6. Auxiliary Drum Park Switch
- H7. Front Drum Pawl Switch
- H8. Rear Drum Pawl Switch
- H9. Auxiliary Drum Pawl Switch
- H10. Front Drum Working Brake Pedal
- H11. Rear Drum Working Brake Pedal

J — Swing Controls

- J1. Swing Handle
- J2. Swing Lock Switch
- J3. Swing Brake Switch
- J4. Swing Holding Brake Switch

K — Travel Controls

- K1. Right Crawler Handle
- K2. Left Crawler Handle
- K3. Travel Detent Selector
- K4. Travel Park Switch
- K5. Right Crawler Pedal
- K6. Left Crawler Pedal
- K7. Travel Speed Selector

(1) Past production only.

(2) Carefully follow instructions in Limit Devices section when by-passing a limit.

CONTROLS IDENTIFICATION AND FUNCTION

See Figure 3-3 for following instructions.

A – Power Controls

A1. Engine Ignition Switch

Insert key and rotate CLOCKWISE to RUN position to turn on the crane's electric system.

Rotate fully CLOCKWISE to START engine. *RELEASE to RUN position as soon as engine starts.* For QSC8.3 or QSL 340 engine, wait for WAIT-TO-START light to go out before starting engine.

Rotate COUNTERCLOCKWISE to STOP engine and to turn off crane's electric system.

NOTE: Stopping engine in an emergency causes all brakes to apply and any functions being operated to stop — *beware that functions stop abruptly.*



WARNING

Unauthorized Start-Up!

Always STOP engine and remove key before leaving crane unattended. This practice will prevent unauthorized personnel from operating crane.

B – Engine Controls

B1. Engine Warning/Diagnostic Lights

Refer to Engine Diagnostics in Section 10 of the Crane Service Manual for instructions.

NOTE: To active engine fault codes: (1) STOP engine; (2) move ignition switch to RUN position; and (3) move hand throttle forward and back three times in succession.

B2. Ether Starting Aid Switch (for 6CTA8.3-C260 or QSL 340 engine only)



DANGER

Explosion Hazard – QSC8.3 or QSL 340 Engine!

To avoid engine damage, do not use starting-aid fluids. This engine is equipped with an intake pre-heater. Using starting-aid fluids can cause an explosion and severe burns to personnel.

Press and hold TOP of rocker for approximately three seconds to FILL starting aid valve with a measured shot of ether.

RELEASE rocker to DISCHARGE shot of ether into engine air inlet manifold.

CAUTION

Engine Damage!

Using too much ether can damage engine. See engine manual for cold weather starting instructions and precautions.

B3. Engine Hand Throttle

Pull handle BACK to INCREASE engine speed.

Push handle FORWARD to DECREASE engine speed.

NOTE: Selected engine speed will be maintained when handle is released.

Speed of crane functions depends on engine speed and on how far control handles are moved from off.

Engine speed must be fast enough to provide sufficient power for work being done. *Engine can stall under load if engine speed is too slow.*

B4. Engine Foot Throttle

PRESS pedal to INCREASE engine speed above hand throttle setting.

RELEASE pedal to DECREASE engine speed to low idle or to hand throttle setting.

B5. Engine Clutch Pedal

Refer to Figure 3-11 for pedal operation.

Push pedal DOWN and FORWARD to DISENGAGE clutch.

Push pedal REARWARD and UP to ENGAGE clutch.

See Engine Start-Up for precautions.

B6. Emergency Engine Stop Switch

Push knob DOWN to STOP engine only in an emergency — for example, if a crane function does not stop when control handle is released to off (center position) or any other uncontrolled motion of a crane function is observed.

Beware — when knob is pushed down, engine stops, brakes apply, and any *functions being operated come to an abrupt stop.*

NOTE: Knob must be pulled up before restarting engine.

If the emergency stop switch has been activated, test all disk brakes for proper operation before putting the crane back in service. See Section 2 of Service Manual for procedure.

NOTE: Use engine ignition switch (A1) to stop engine for normal operating conditions.

B7. Battery Disconnect Switch

Turn disconnect handle CLOCKWISE to CONNECT battery circuit.

Turn disconnect handle COUNTERCLOCKWISE to DISCONNECT battery circuit for the following reasons:

- When servicing crane's electrical control system.
- If desired, to prevent batteries from discharging when the crane is stored for extended periods of time.
- If desired, to prevent crane from being started by unauthorized personnel.

CAUTION**Engine Damage!**

To avoid possible engine fault codes and undesirable operation, make sure engine ignition switch has been off two minutes before disconnecting batteries.

Do not rely on this switch to protect crane's electronic systems when welding. Disconnect battery cables at batteries before welding.

The handle can be removed in the out when in the disconnect position to keep unauthorized personnel from connecting the batteries and starting the crane.

C – Accessory Controls**C1. Dome Light Switch**

Dome light has a two-position switch with on and off settings.

The dome light can be rotated to different positions.

C2. Panel Light Switch

Press TOP of rocker to TURN ON panel lights.

Press BOTTOM of rocker to TURN OFF panel lights.

C3. Heater/Air Conditioner Fan Switch

This fan operates only when heater or air conditioner is on.

Press TOP of rocker to TURN ON fan at high speed.

Press BOTTOM of rocker to TURN ON fan at low speed.

C4. Horn Switch

PRESS and hold button to TURN ON horn. *Sound horn when necessary to warn or signal personnel while crane is being operated or serviced.*

RELEASE button to TURN OFF horn.

C5. Air Conditioner Temperature Selector

Rotate knob clockwise for cooler temperatures and counterclockwise for warmer temperatures.

C6. Air Conditioner/Heater Switch

Press TOP of rocker to TURN ON cab heater.

CENTER rocker to TURN OFF cab air conditioner or heater.

Press BOTTOM of rocker to TURN ON cab air conditioner.

NOTE: The shut-off valves in heater hoses (Figure 3-4) at engine must be open for heater operating.

The shut-off valves can be closed to block hot water flow through heater core during warm weather.

The shut-off valve in the supply line can be partially opened and closed to regulate heat.

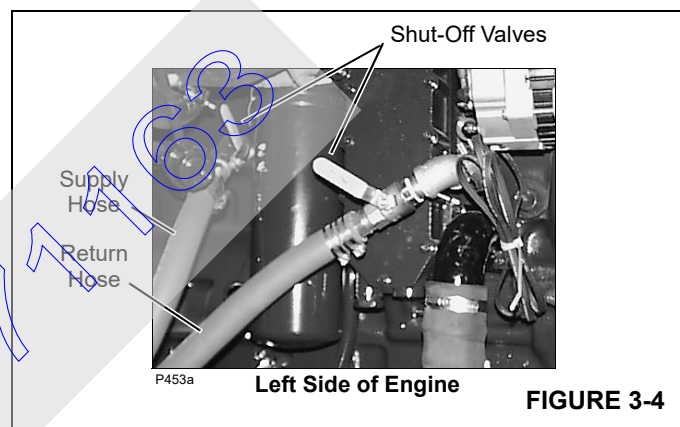
**FIGURE 3-4****C7. Front Windshield Wiper Switch****C8. Overhead Windshield Wiper Switch**

Press TOP of rocker to TURN ON wiper and operate it in HIGH SPEED.

CENTER rocker to TURN ON wiper and operate it in LOW SPEED.

Press BOTTOM of rocker to TURN OFF wiper.

C9. Defroster Fan

Defroster fan has a three-position switch with off, low, and high settings.

C10. Tinted Visor

Move to desired position to shade sun light.

C11. Machinery Heaters

To aid starting in cold weather, plug in heaters at shut-down; unplug heaters at start-up.

The hydraulic tank can be equipped with two thermostatically controlled heaters (120 V or 240 V), designed to keep oil

temperature 30°F (17°C) warmer than ambient temperature. To set each thermostat, remove cover and turn knob clockwise to 100°F (38°C).

Engine is equipped with a 1500 W block heater (120 V) without a thermostat.

C12. Windshield Washer Switch

Depress and hold TOP end of rocker to SPRAY washing solution onto upper front window.

RELEASE rocker to STOP spraying washing solution onto upper front window.

NOTE: Washer tank is mounted in lower right corner of operator's cab. Fill tank with a quality brand washing solution that will not freeze during cold weather.

D – Indicators

D1. Digital Display and Selector Switch

Allows operator to monitor three groups of crane information: operating conditions, operating limits, and system faults. See Digital Display Readings in this section for tables identifying information which can be displayed.

Press top or bottom of selector to scroll up or down through display readings. Release selector when desired information is displayed.

D2. Operating Limit Alert

GLOWS YELLOW and a BUZZER comes ON to alert operator that an operating limit has been reached (limit automatically appears on digital display). See Digital Display Readings for a list of operating limits, function responses, and corrective actions.

D3. System Fault Alert

GLOWS RED and a BEEPER comes ON to alert operator that a system fault exists (fault appears on digital display). See Digital Display Readings for a list of system faults, causes, function responses, and corrective actions.

D4. Rotation Indicators

Move UP and DOWN to signal the operator by feel, that boom hoist, luffing hoist, or corresponding drum is turning.

NOTE: Rotation indicators are pin-type actuators located under handle covers.

Indicator movement corresponds to hoist or drum speed

NOTE: Boom and load bounce while traveling or performing other operations may cause boom hoist rotation indicator to move up and down occasionally, even if boom hoist is not being operated.

D5. Level

Indicates crane levelness from front to rear and from side to side as shown in Figure 3-5. The level is mounted on front of rotating bed and is visible through right side window in the operator's cab.

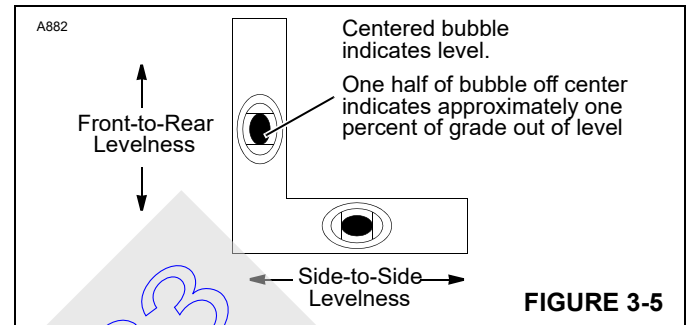

WARNING

Tipping Hazard!

Unless otherwise specified on capacity chart, all crane operations must be performed with crane *level* to within one percent of grade. Operating crane at a greater angle could cause crane to tip.

D6. Mirrors

One adjustable interior mirror lets operator view load drums.

Two adjustable exterior mirrors lets operator view to rear of crane. Both mirrors can be rotated inward for shipping.

D7. Rated Capacity Indicator/Limiter Console

See separate Rated Capacity Indicator/Limiter Manual for operation.

D8. Engine Hourmeter

Shows total number of hours engine has been run.

D9. Boom Angle Indicator

Shows angle of boom in degrees above horizontal. Boom and luffing jib angles can also be viewed under OPERATING CONDITIONS on digital display. See Figure 3-3 for identification of various boom and luffing jib angles.

! WARNING
Overload Hazard!

Use boom angle indicator only as a guide to position boom near angle corresponding to radius for given load. The radius shall govern capacity. Exceeding radius given in capacity chart can result in tipping or structural damage.

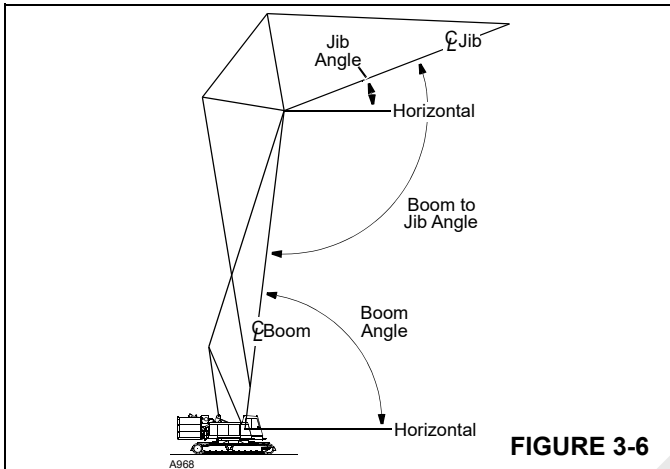

E – Gauges

E1. Fuel Level Gauge

Shows how much fuel is left in fuel tank.

E2. Engine Water Temperature Gauge

Shows temperature of coolant in engine cooling system. See your engine manual for operating conditions.

E3. Engine Oil Pressure Gauge

Shows pressure of oil in engine lubricating system. See your engine manual for operating conditions.

E4. Battery Voltage Gauge

Shows condition of battery charging system. For a complete description of meter readings, see Voltmeter Operation in this section.

E5. Hydraulic Oil Temperature Gauge

Shows temperature of oil in hydraulic tank.

A sight gauge is also located on hydraulic tank.

CAUTION
Pump Damage!

Do not operate crane functions until temperature of hydraulic oil is at least 60°F (16°C). Damage to pumps and related hydraulic parts can result if this precaution is not followed.

Table 3-2 Bypassable Limit Identification — PRIOR TO CRANE S/N 7771165

Limit	USA and non-EUROPEAN	EUROPEAN	
	Limit Bypass Switch (F1) (momentary)	Limit Bypass Switch (F1) (momentary)	Jib Up Limit Bypass Switch (F6) (maintained) ¹
Boom Maximum Up	Yes or No ²	No	No
Boom Maximum Down	Yes	Yes	No
Block Up (each load drum)	Yes	Yes	No
Bail – Max and Min (each load drum)	Yes	Yes	No
Load Moment	Yes	Yes	No
Luffing Jib Max Up	Yes	No	Yes
Luffing Jib Max Down	Yes	Yes	No

¹ Use only for rigging.

² The boom up limit cannot be bypassed on current production cranes. To determine if the boom up limit can be bypassed on your crane, perform the test given below.

LIMIT BYPASS TEST: Perform the following test to determine if the boom up limit on your crane can be bypassed or not:

1. Lower the boom onto blocking at ground level.
2. Have an assistant push the boom stop limit switch plunger down to trip the boom up limit switch open (see Section 4 of Crane Service Manual).
3. Rotate limit bypass key (F1) to the bypass position and hold.
4. Try to boom up SLOWLY — do not raise the boom any higher than necessary to perform the test:
 - a. If the boom rises, your boom up limit can be bypassed.
 - b. If the boom does not rise, your boom up limit cannot be bypassed.
5. The test is complete: release the limit bypass key and the limit switch plunger to the normal operating positions.

Table 3-3 Bypassable Limit Identification — CRANE S/N 7771165 AND NEWER

Operating Limit	non-CE ¹	non-CE Luffing Jib Setup Mode On ²	CE	CE Luffing Jib Setup Mode On ²	CE External Override Switch
Boom Maximum Up	No	No	No	No	No
Block Up (Drum 1, 2, and 8)	Yes	Alarm ⁴	Yes ⁵	Alarm	Alarm
Block Up (Boom Hoist)	Yes	Alarm	Yes ⁵	Alarm	Alarm
Maximum Bail (Drum 1, 2, and 8)	Yes	No	No	No	No
Minimum Bail (Drum 1, 2, and 8)	Yes	No	No	No	No
Load Moment (Drum 1, 2, and 8))	Yes	Alarm	Yes ^{6,7}	Alarm ⁸	Alarm
Load Moment (Boom Hoist)	Yes	Alarm	Yes ^{6,7}	Alarm ⁸	Alarm
Pawl In (Drum 1, 2, and 8)	Yes	No	Yes	No	No
Luffing Jib Max Up 1	Yes	Alarm	No	Alarm	Alarm
Luffing Jib Max Up 2	Yes ^{9,10}	Alarm ¹¹	No	Alarm ¹¹	Alarm
Luffing Jib Max Down 1	Yes	Alarm	No	Alarm	Alarm
Luffing Jib Max Down 2	Yes ¹⁰	Alarm	No	No	No
Counterweight Max Up	Yes	No	Yes	No	No

¹ CE = Cranes that comply with 2010 European Requirements.

² Use only for rigging. See F1. Limit Bypass Switch topic on page 3-17 for instructions.

³ See Rated Capacity Indicator/Limiter Operation Manual.

⁴ Alarm = Operating limit alarm comes on and fault appears in system fault screen of Digital Display. Operation (motion) of the corresponding function is not stopped. The alarm is not bypassable.

⁵ Bypassable if below chart angle, otherwise cutout and alarms active.

⁶ Bypassed from 100-110% rated capacity with reduced speeds (bypass switch not required).

⁷ Bypassable when boom or luffing jib is below chart angle for rigging purposes.

⁸ Only if below chart angle. Otherwise cutout and alarm is active.

⁹ Bypassable only if boom is below 50 degrees. Otherwise cutout and alarm is active.

¹⁰ Bypassable only if handle is returned to neutral while holding bypass switch. Otherwise cutout and alarm is active.

¹¹ Only if boom is below 50 degrees. Otherwise cutout and alarm is active.

F – Special Controls/Indicators

F1. Limit Bypass Switch



WARNING

Carefully follow instructions in Limit Devices topic when by-passing an operating limit.

This switch bypasses the limits identified in Table 3-2 and Table 3-3.

Press and hold TOP of rocker (or insert and turn optional KEY) to BYPASS reached operating limits. This position allows functions to be operated beyond the limits. If not equipped with a key, the lock on rocker must be moved up before rocker can be pressed.

RELEASE rocker (or optional key) to ACTIVATE limits. This position allows limits to stop functions in normal manner. **Switch must be in this position for normal operation. Otherwise, structural damage can occur.**

Remove optional key to prevent unauthorized operation.

NOTE: To bypass the limits listed in Table 3-3 for luffing jib setup, proceed as follows:

- Select and confirm luffing jib setup mode.
- Rotate limit bypass switch (F1) clockwise and release. The limits will remain bypassed for 10 seconds.
- Move the desired control handle (luffing hoist, boom hoist, load drum) — one control handle at a time — in the required direction. The limits will remain bypassed for as long as the handle is moved in either direction.
- The limits will remain bypassed for 10 seconds after the control handle(s) is returned to off.

F2. Crane Mode Selector



WARNING

Moving Load Hazard!

Operator must select proper operating mode prior to operating.

Unexpected drum motion or improper limit responses can result if wrong mode is selected.

Insert key. Turn CLOCKWISE and hold to SELECT desired crane mode. CRANE MODE will appear on first line of digital display. Available crane modes will then scroll by (one to two seconds apart) on second line of display.

Turn key COUNTERCLOCKWISE to CONFIRM desired crane mode when it appears on digital display.

Release key to CENTER. *Remove key to prevent unauthorized operation.*

NOTE: To check crane mode in effect at anytime, turn key to the CONFIRM position. Current mode will appear on digital display.

The crane mode in effect when engine is stopped remains in memory. At each start-up, crane mode in effect must be confirmed or another mode must be selected and confirmed. Load drums and boom hoist are not operable until this step is performed (operating limit alert will come on and CONFIRM MODE will appear on digital display if operation is attempted).

The following crane modes are available:

- **STANDARD**
Use this mode for all normal load handling operations. Load drums can be operated in full-power or free fall.
- **CLAMSHHELL**
Use clamshell mode to operate a clamshell bucket. In this mode, front drum operates as closing line and rear drum as holding line. Also clamshell power down and closing features are turned on.
- **DRAGLINE**
Use dragline mode for dragline operation. In this mode, front drum operates as dragline and rear drum as hoist line.
- **LUFFING JIB**
Same as standard mode, except in this mode rear drum operates as luffing hoist and must be rigged accordingly. See Luffing Jib Rigging Guide for raising and lowering instructions when equipped with a luffing jib attachment. **Free fall for rear drum is inoperable in this mode.**



WARNING

Falling Boom Hazard!

Setup modes are provided for crane/luffing jib assembly and disassembly purposes only.

Do not use these modes for normal load handling operations.

Read and follow Assembly and Disassembly instructions in Section 4 of this manual and in Section 4 of Luffing Jib Operator's Manual.

- LUFFING JIB SETUP

On crane S/N 7771165 and newer, this mode allows the limits listed in Table 3-3 to be bypassed with Limit Bypass Switch (F1).

- **SETUP**

In the setup mode:

- Swing speed is reduced to 1/2 its normal speed.
- Free coast is turned off (swing motion stops when handle is released to off).
- Boom MAX UP limit is turned off.
- Seat switch is disabled. Allows operator to operate boom hoist either with handle in cab or with remote control when installing and removing counterweight. The remote control has priority over handle in cab.

Follow the Assembly and Disassembly instructions in Section 4 of this manual.

- **FREE FALL**

Allows front and/or rear drum to be operated in free-fall. See topic H - Load Drum Controls for a description of free-fall operation.

The FREE FALL ON mode for either drum is not displayed until corresponding brake pedal is pressed down fully.

To turn on free-fall, proceed as follows (following example is for front drum — process is same for rear drum):

1. Bring drum to a complete stop.
2. Press down front drum brake pedal fully.
3. Turn mode selector key CLOCKWISE and hold until FRONT DRUM FFALL ON appears on display.
4. Turn mode selector key COUNTERCLOCKWISE to turn on free-fall.
5. FRONT DRUM FREE FALL light will glow yellow.

To turn off free fall, proceed as follows (following example is for front drum — process is same for rear drum):

1. Press down front drum brake pedal fully to bring drum to a complete stop.
2. Turn mode selector key CLOCKWISE and hold until FRONT DRUM FFALL OFF appears on display.
3. Turn mode selector key COUNTERCLOCKWISE to turn off free fall.
4. FRONT DRUM FREE FALL light will turn off.

NOTE: When free fall is off, the corresponding drum operates in full-power. See Load Drum Handles for a description of full-power operation.

F3. Front Drum Free Fall Light

F4. Rear Drum Free Fall Light

Glowes YELLOW when free fall is on for corresponding drum.

F5. Seat Switch

Prevents crane from being operated until operator is seated. When operator is not seated, all control handles are inoperable, all parking brakes are applied, free fall is turned off, and travel detent is turned off.

F6. Jib Up Limit Bypass Switch

This switch is not provided on current production cranes.

This switch bypasses the limits identified in Table 3-2.

This switch is provided to allow the jib up limit (maximum boom to luffing jib angle) to be by-passed when boom and luffing jib are lowered to the ground.

Turn key COUNTERCLOCKWISE to ACTIVATE jib up limit and allow it to operate normally. **Key must be in this position for normal operation. Otherwise, structural damage can occur.**

Remove key to prevent unauthorized operation.

G – Boom Hoist Controls

Boom hoist cylinders are equipped with electrically controlled hydraulic holding valves.

- Corresponding holding valves (up or down) open when boom hoist handle is moved in either direction from off to raise or lower the boom.
- Holding valves close to hold the boom in position when boom hoist handle is moved to off.
- Holding valves close to hold boom in position if power is lost for any reason.

G1. Boom Hoist Handle

Move handle to REAR to RAISE boom.

Release handle to CENTER to STOP boom and hold it in position.

Move handle to FRONT to LOWER boom.

G2. Boom Hoist Park Switch

Boom hoist park switch enables and disables boom hoist operation. With boom hoist park on, the boom hoist handle is inoperable and holding valves are closed to hold boom hoist cylinders in position.

Press TOP of rocker to TURN ON boom hoist park.

Press BOTTOM of rocker to TURN OFF boom hoist park (allow boom hoist cylinders to be operated).

G3. Boom Cylinder Hold Switch

Press TOP of rocker to TURN ON boom cylinder hold. When this feature is on, boom hoist cylinder movement caused by thermal expansion and contraction or internal leakage is monitored by crane's computer when boom hoist control handle is off (in neutral).

If cylinders move a predetermined amount in either direction, computer strokes boom hoist pump to maintain a fixed cylinder position.

Press BOTTOM of rocker to TURN OFF boom cylinder hold. When this feature is off, boom hoist cylinders may extend or retract due to thermal expansion and contraction or internal leakage.

NOTE: The boom cylinder hold feature has the following operating characteristics:

- It only operates when switch is on and boom hoist handle is off.
- The boom hoist handle is inoperable on current production cranes.
- It is normal for operator to hear boom hoist pump go on stroke when computer activates system.
- It does not operate when boom hoist park is on or engine is off.
- It does not compensate for any changes in boom angle caused by pendant stretch when a load is lifted or landed.

H – Load Drum Controls

Front and rear drums are equipped with band and disc-type spring-applied, hydraulically-released brakes.

Auxiliary drum is equipped only with a spring-applied, hydraulically-released disc brake.

Brakes apply to stop drums if power is lost for any reason.

Full-Power Operation (Free Fall Off)

Band and disc brakes operate automatically in conjunction with operation of either drum control handle.

- When a drum handle is moved in either direction from off to raise or lower a load, corresponding band and disc brakes release.
- When drum handle is returned to off, band and disc brakes apply to stop drum and hold load in position.

Free Fall Operation (if equipped)

This operation does not apply to the auxiliary drum. See full-power operation.

Automatic operation of band brake is turned off and drum clutch releases when either drum handle is moved to off.

- When a drum handle is moved to rear from off to raise a load, corresponding clutch engages. Band brake must be manually released with foot pedal to allow drum to turn.

There is no power lowering feature in free fall. *If a drum handle is moved forward from off while free falling a load, corresponding band brake will apply.*

- Disc brake prevents motor side of drive from turning until clutch is fully engaged prior to hoisting a load.
- When drum handle is moved to off, corresponding clutch disengages. Band brake must be manually applied with foot pedal to stop drum and hold load in position.

Braking control is variable, from fully applied to fully released, depending on position of foot pedal.

WARNING Falling Load Hazard!

When operating in free-fall, load will lower uncontrolled if drum brake is not applied with brake pedal when drum control handle is moved to off.

Be ready to apply drum brake with brake pedal so lowering speed can be controlled and load can be stopped immediately when necessary.

CAUTION

Machinery/Boom Damage!

While free falling a load:

- Do not move drum handle in either direction from off.
- Do not turn off free fall.
- Do not turn on drum park.

Shock load damage to machinery or boom can result. Bring drum to a complete stop with brake pedal before performing above operations.

H1. Front Drum Handle

H2. Rear Drum or Luffing Jib Handle

H3. Auxiliary Drum Handle

See Figure 3-7 for following procedure.

Move handle to FRONT to LOWER load (or luffing jib on rear drum).

Release handle to CENTER to STOP load (or luffing jib on rear drum) and hold it in position.

In free-fall mode, drum brake must be applied with brake pedal to stop and hold load.

Move handle to REAR to RAISE load (or luffing jib on rear drum).

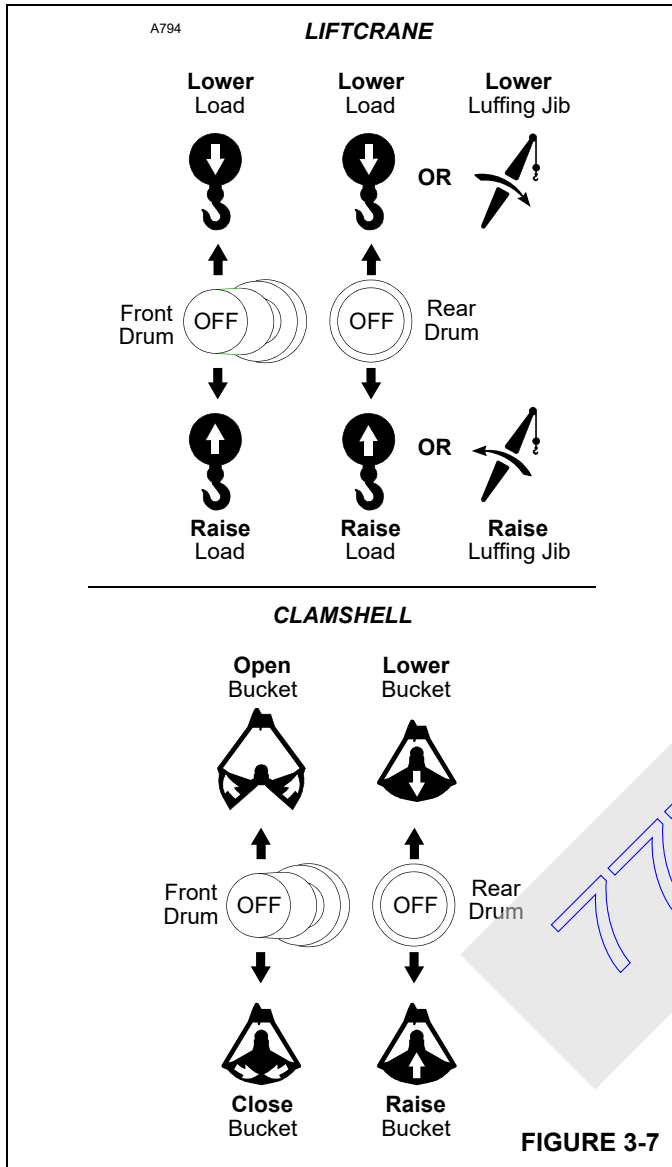

H4. Front Drum Park Switch
H5. Rear Drum Park Switch
H6. Auxiliary Drum Park Switch

Drum park switches enable and disable drum operation. With drum park on, corresponding drum handle is inoperable and brakes are applied.

Press TOP of rocker to TURN ON corresponding drum park.

Press BOTTOM of rocker to TURN OFF corresponding drum park (allow drum to be operated).

H7. Front Drum Pawl Switch
H8. Rear Drum Pawl Switch
H9. Auxiliary Drum Pawl Switch

Ratchet and pawl provides a positive means of locking corresponding drum in position when not in use.

Press TOP of rocker to ENGAGE pawl with ratchet.

Press BOTTOM of rocker to DISENGAGE pawl from ratchet.

NOTE: A drum will not operate in lower direction until corresponding pawl is disengaged.

The corresponding drum will stop lowering if pawl is engaged while lowering a load.

CAUTION

Machinery Damage!

Do not engage drum pawl while lowering a load. Damage to pawl or drum may result.

Bring drum to a complete stop and then engage drum pawl.

H10. Front Drum Working Brake Pedal**H11. Rear Drum Working Brake Pedal**

See Figure 3-8 for following procedure.

Each free fall equipped drum has a brake pedal that can be pressed down at anytime to stop the drum.

PRESS pedal to APPLY drum brake in relation to pedal movement. Fully press and latch pedal to fully apply brake.

RELEASE pedal to RELEASE drum brake gradually as pedal is eased up.

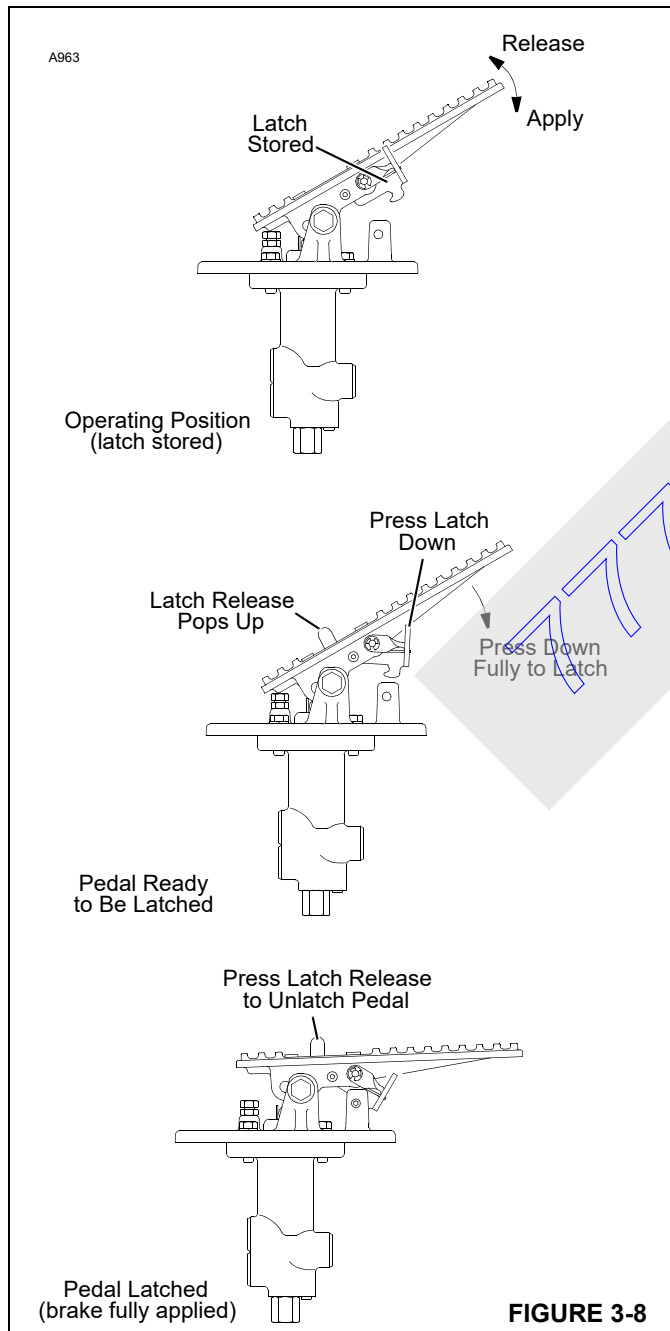
**FIGURE 3-8****J – Swing Controls****J1. Swing Handle**

Dual-axis handle allows swing and boom hoist to be operated at the same time with one handle.

Move handle to LEFT to SWING LEFT. Swing speed increases in relation to handle movement.

Release handle to CENTER to STOP. Swing speed decreases to off and rotating bed slows to a stop. Move swing control handle in the opposite swing direction to stop swing motion quicker.

Press swing holding brake switch to hold stopped rotating bed in position.

Move handle to RIGHT to SWING RIGHT. Swing speed increases in relation to handle movement.

NOTE: If equipped, the optional swing alarm will beep to warn personnel when rotating bed is swung in either direction.

J2. Swing Lock Switch

Swing lock provides a positive means of locking rotating bed in position when swinging is not required.

Press FRONT of rocker to ENGAGE swing lock with ring gear.

Press REAR of rocker to DISENGAGE swing lock from the ring gear.

CAUTION
Swing Lock Damage!

Do not engage swing lock while swinging; structural damage to swing lock and ring gear will result. Do not swing until swing lock is disengaged.

J3. Swing Brake Switch

Swing is equipped with a spring-applied, hydraulically-released disc brake.

Press FRONT of rocker to TURN ON swing brake.

Press REAR of rocker to TURN OFF swing brake.

J4. Swing Holding Brake Switch

Use swing holding brake switch (on side of swing/boom hoist handle) to hold rotating bed in position for short periods of time during operating cycle. Swing brake will apply and swing handle will be inoperable while switch is pressed.

PRESS button to APPLY swing holding brake.

RELEASE button to RELEASE swing holding brake.

CAUTION**Swing Drive/Boom Damage!**

Do not apply swing holding brake or turn on swing park while swinging; brake will bring rotating bed to an abrupt stop. This action could cause damage to boom from side loading or damage to swing drive from shock loading. Bring rotating bed to smooth stop with swing handle and then apply swing holding brake or turn on swing park.

K – Travel Controls

Crawlers are equipped with spring-applied, hydraulically-released disc brakes.

- Both crawler brakes release when either crawler handle is moved from off.
- Both crawler brakes apply when both crawler handles are moved to off.
- Both crawler brakes apply to hold the crane in position if power is lost for any reason.

K1. Right Crawler Handle**K2. Left Crawler Handle**

NOTE: The following directions of travel are with *crawler drive shafts to rear of operator*.

Move handle to **FRONT** to travel **FORWARD**. Speed increases in relation to handle movement.

Release handle to **CENTER** to **STOP** traveling.

Move handle to **REAR** to travel in **REVERSE**. Speed increases in relation to handle movement.

NOTE: If equipped, optional travel alarm will beep to warn personnel when crane is traveled in either direction.

K3. Travel Detent Selector

NOTE: Travel detent selector allows crawlers to be operated in either direction at a selected speed without operator's hand on crawler handles.

Move both crawler handles in either direction from off to select desired speed and direction of travel. **PULL UP** and release **KNOB** on right crawler handle to **TURN ON** the travel detent. Release handles to off. The crawlers will continue to travel at selected speed and direction.

Slightly move either crawler handle in opposite direction or pull up and release knob on right handle to **TURN OFF** travel detent.

K4. Travel Park Switch

The travel park switch enables and disables travel operation. With travel park on, the travel handles (or pedals) are inoperable and the travel brakes are applied.

Press **TOP** of rocker to **TURN ON** travel park.

Press **BOTTOM** of rocker to **TURN OFF** travel park (allow travel to be operated).

K5. Right Crawler Pedal**K6. Left Crawler Pedal**

For cranes equipped with crawler pedals, pedals take the place of crawler handles — no travel detent is available.

NOTE: The following directions of travel are with *crawler motors to rear of operator*.

Tilt pedal to **FRONT** to travel **FORWARD**. Speed increases in relation to pedal movement.

Release pedal to **CENTER** to **STOP** traveling.

Tilt pedal to **REAR** to travel in **REVERSE**. Speed increases in relation to pedal movement.

K7. Travel Speed Selector

Press top end of rocker to operate travel motors in **HIGH** speed. High speed operation provides maximum available travel speed for traveling long distances.

Press **BOTTOM** end of rocker to operate travel motors in **LOW** speed. Low speed operation provides smoother starts and stops and more precise control of the travel motors than high speed.

In low speed, travel motors operate at approximately 1/3 the speed of high speed.

NOTE: It is okay to change travel speed while traveling:

The travel motors will shift immediately from high to low when low speed is selected.

The travel motors will not shift from low to high when high speed is selected until:

- Engine speed is at high idle.
- Hydraulic pressure is low enough to allow motors to shift from low to high speed.

REMOTE CONTROLS

The following remote controls are provided for setup:

- Counterweight remote control in left side enclosure.
- Carbody jack handles on front of carbody.
- Crawler connecting pin handles on front of carbody.

See Remote Controls in this section for operating instructions.

**WARNING****Avoid Death or Serious Injury!**

Read and understand instructions in Crane Assembly and Disassembly Guide before selecting setup mode or using setup controls.

LIMIT DEVICES**Counterweight Max Up Limit**

Prevents over-tensioning the counterweight lifting pendants when installing counterweights and parking the boom.

If the boom is lowered too far while the lifting pendants are installed, the counterweight tray rises and trips either limit switch at the rear of the crane. The computer then stops boom down operation. The operating limit alert will turn on and COUNTERWEIGHT MAX UP will appear on the digital display.

Boom Maximum Up Limit

Automatically stops the boom when it is raised to a preset maximum angle:

- 83° for Boom without Luffing Jib
- 88° for Boom with Luffing Jib when the boom up limit **can be bypassed**.
- 89° for Boom with Luffing Jib when the boom up limit **cannot be bypassed**.

The boom can be lowered after the limit is contacted.

**WARNING****Falling Boom/Jib Hazard!**

If you bypass boom up limit for any reason, DO NOT allow physical boom stops to bottom out. Boom butt could be damaged, causing boom and jib to fall over backwards.

Crush Hazard!

Maintain constant communication between operator and assistant during following steps.

Stay clear of moving parts.

Boom Maximum Down Limit (if equipped)

Automatically stops the boom when it is lowered to a preset minimum angle (usually 0°).

The boom can be raised after the limit is contacted.

The appropriate limit bypass switch must be moved to the bypass position to lower the boom below the limit.

**WARNING****Falling Boom Hazard!**

When lowering boom below down limit, do so slowly with extreme caution. Do not lower boom to point where less than two full wraps of wire rope are on boom hoist drums; wire rope could be pulled out of drums allowing boom to fall.

Block Up Limit

Automatically stops the boom and luffing jib (if equipped) from lowering and all loads from hoisting if a load contacts a block-up limit switch.

The load on the corresponding drum can be lowered and the boom and luffing jib can be raised after a block-up limit switch is contacted.

The appropriate limit bypass switch must be moved to the bypass position to hoist a load above the limit.

**WARNING****Two-Blocking Hazard!**

If it is necessary to hoist a load above block-up limit, do so slowly with extreme caution to prevent two-blocking.

Do not hoist load above minimum block clearance given on Range Diagram in Capacity Chart Manual.

Do not use limit bypass switch to lower boom or luffing jib after block-up limit is contacted; two-blocking could occur, causing load to fall.

Luffing Jib Max Up Limit

Prior to Crane S/N 7771156

Automatically stops the luffing jib when the boom to luffing jib angle is 168°.

The luffing jib can be lowered after the limit is contacted.

For rigging purposes only (when boom and luffing jib are being raised or lowered from or to ground), the appropriate limit bypass switch must be moved to the bypass position to raise the luffing jib above the limit.



WARNING

Falling Boom/Jib Hazard!

Do not raise luffing jib above up limit during normal operation. Structural damage will occur, possibly causing boom and luffing jib to be pulled over backwards.

Luffing Jib Max Up 1 Limit

Crane S/N 7771156 and Newer

This is a programmed limit which automatically stops the luffing hoist when the boom to luffing jib angle is 168°.

The limit bypass switch must be turned to the bypass position to allow the jib to be raised an additional 3° to the LUFFING JIB MAX UP 2 limit.

The luffing jib can be lowered after this limit is contacted.

Luffing Jib Max Up 2 Limit

Crane S/N 7771156 and Newer

This is a limit switch which automatically stops the luffing hoist when the boom to luffing jib angle is 171°.

For non-CE cranes, this limit can be bypassed only when the attachment is lowered to the ground (boom below 50°) and the handle is returned to neutral while holding the bypass switch in the bypass position.

For CE cranes, the luffing jib cannot be lowered after the Jib Maximum Up 2 limit is contacted until the limit switch is reset. When the limit is contacted, the following screen will appear on the digital display.

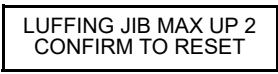

Once the screen appears, confirm it to reset the limit switch. The luffing jib can then be lowered.



WARNING

Falling Boom/Jib Hazard!

Proceed slowly when operating the luffing jib above the Max Up 1 limit.

Do not raise luffing jib above Max Up 2 limit. Structural damage will occur, possibly causing boom and luffing jib to be pulled over backwards.

Luffing Jib Max Down Limit

Prior to Crane S/N 7771156

Automatically stops the luffing jib when the boom to luffing jib angle is 60°.

The luffing jib can be raised after the limit is contacted.



WARNING

Falling Boom/Jib Hazard!

Do not lower luffing jib below down limit. Structural damage will result, possibly causing boom and luffing jib to collapse.

Luffing Jib Max Down 1 Limit

Crane S/N 7771156 and Newer

This is a programmed limit which automatically stops the luffing hoist when the boom to luffing jib angle is 60°.

The luffing jib can be raised after this limit is contacted.

Luffing Jib Max Down 2 Limit

Crane S/N 7771156 and Newer

This is a limit switch which automatically stops the luffing hoist when the boom to luffing jib angle is 57°.

This limit can be bypassed for non-CE cranes.

For CE cranes, the luffing jib cannot be raised after jib maximum down 2 limit is contacted until the limit switch is reset. When the limit is contacted, the following screen will appear on the digital display.

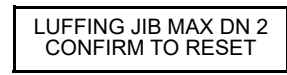

Once the screen appears, confirm it to reset the limit switch. The luffing jib can then be raised.



WARNING

Falling Boom/Jib Hazard!

Do not lower luffing jib below minimum angle given in Luffing Jib Raising Procedure in Capacity Chart Manual. Structural damage can result, possibly causing boom and luffing jib to collapse.

Maximum Bail Limit

Automatically stops the corresponding load drum from hoisting when there is a preset maximum number of wire rope layers on the drum.

The load can be lowered after the limit is contacted.

The appropriate limit bypass switch must be moved to the bypass position to hoist the load above the limit.



WARNING

Falling Load Hazard!

Do not exceed maximum allowable spooling capacity given on Wire Rope Specifications Chart in operator's cab. Wire Rope could jump off drum allowing load to fall.

Minimum Bail Limit

Automatically stops the corresponding load drum from lowering when there are three wraps of wire rope remaining on the drum.

The load can be hoisted after the limit is contacted.

The appropriate limit bypass switch must be moved to the bypass position to lower load below the limit.



WARNING

Falling Load Hazard!

When lowering load below minimum bail limit, do so slowly with extreme caution. Do not lower load to point where less than three full wraps of wire rope are on drum. Wire rope could be pulled out of drum allowing load to fall.

Load Moment Limit

See separate Rated Capacity Indicator/Limiter Manual for operating instructions.



WARNING

Overload Hazard!

Rated capacity indicator/limiter has been installed on crane to aid operator.

Presence of rated capacity indicator/limiter on crane in no way substitutes for or lessens requirement that operator knowledge, experience, and judgment are required to ensure safe operation of crane.

Before using rated capacity indicator/limiter, operator shall verify that it is properly calibrated.

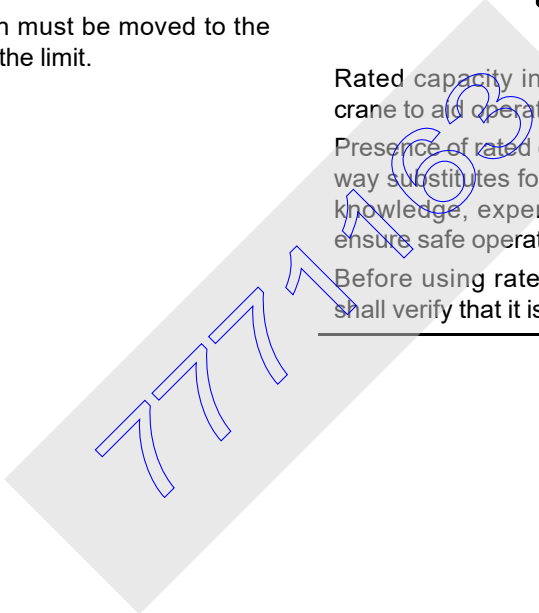

SEAT CONTROLS

A794

Avoid Damage!

Disconnect electric cord from rear of right console before removing seat from operator's cab.

SEAT FORE-AFT (adjusts seat only) -

Push release lever to left to unlock. Using body pressure, slide seat forward or rearward to desired position. Release lever and make sure it is latched.

SEAT AND CONSOLE FORE-AFT (adjusts seat and consoles) -

Push release lever to left to unlock. Using body pressure, slide seat and consoles forward or rearward to desired position. Release lever and make sure it is latched.

SEAT HEIGHT -

Push release lever to left to unlock. Using body pressure, raise and lower seat to desired position. Release lever and make sure it is latched.

ARMREST (unzip cover to expose screw at rear of each armrest) -

Turn screws to raise and lower armrests to desired position. Armrests can be rotated up when not needed.

BACKREST - Rotate knob to raise and lower backrest to desired position.

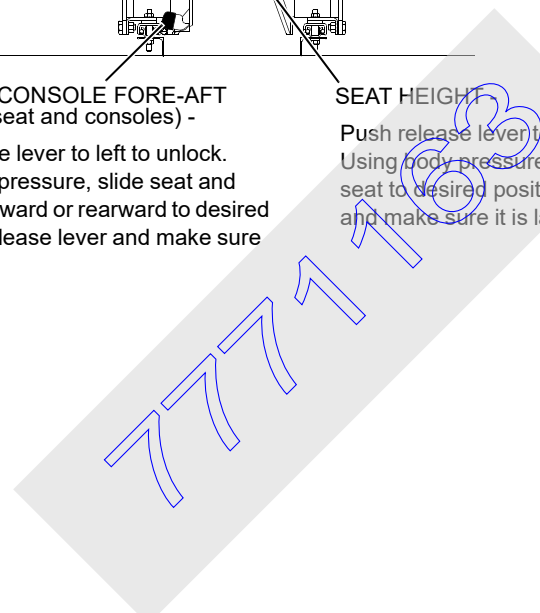
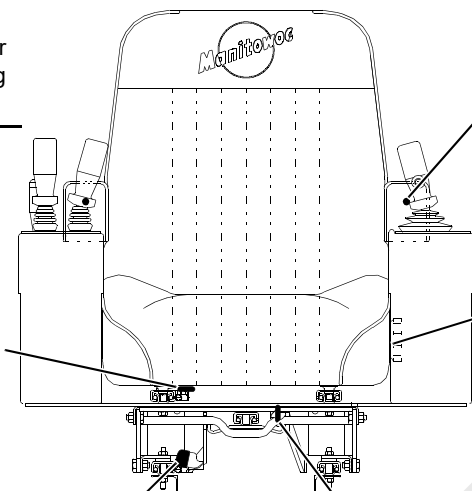

FIGURE 3-9

PREPARING CRANE FOR OPERATION



WARNING

Read Capacity Charts!

Do not attempt to operate crane without first reading and understanding capacity charts.

Crane must be rigged and operated according to instructions given in capacity charts and rigging drawings.

Unless otherwise specified in capacity charts, all crane operations must be performed with crane level to within one percent of grade; otherwise, crane could tip.

Observe minimum block weight requirement given on capacity charts.

Beware when operating in those areas of capacity chart marked (b) — weight of backstay pendants can pull jib against physical stops if load block or hook and weight ball is not heavy enough. This action will result in sudden unexpected movement of the load.

Make sure crawlers are blocked, if required per capacity chart, prior to raising and lowering attachment. Read and comply with instructions in Crawler Blocking Diagram in Capacity Chart Manual.

Do not operate crane, to include raising boom from ground level, if wind exceeds limits given in Capacity Charts. Contact your local weather station for wind velocity.

Failing to comply with capacity charts can result in tipping or structural failure of boom/luffing jib.

Moving Load Hazard!

Operator must select proper operating mode prior to operation.

Unexpected drum motion or improper limit responses can result if wrong mode is selected.

Limit bypass switches must be in “activate” position and all limits with which crane is equipped must be operational before operating crane.

Avoid injuring personnel in operating area! Sound horn to alert personnel that operation is about to begin.

CAUTION

Avoid Machinery Damage!

Before operating crane at start of each shift, perform preventive maintenance checks and lubrication services listed in your Operator’s Manual. Adjust operator’s seat as shown in Figure 3-9.

Remove *optional* rear drum pressure roller for lift crane operation. Rear drum pressure roller is required for duty-cycle application only.

OPERATION

Engine Start-up



WARNING

Avoid injuring personnel or damaging crane and property!

- Do not start engine if warning or out-of-order sign is present at start controls.
- Check that all controls are off so crane and load do not move when engine is started.
- Check that all personnel are clear of crane before starting engine. *Sound horn to alert personnel.*

See engine manual for additional start-up instructions and precautions.

1. If used, unplug or turn off engine block heater, engine oil pan heater, hydraulic tank heaters and any other heaters crane is equipped with.

NOTE: Manitowoc recommends the use of heaters (engine, hydraulic tank, etc.) to aid start-up when the ambient temperature will be 32°F (0°C) and below.

2. Open hydraulic shut-off valves. (Figure 3-10).

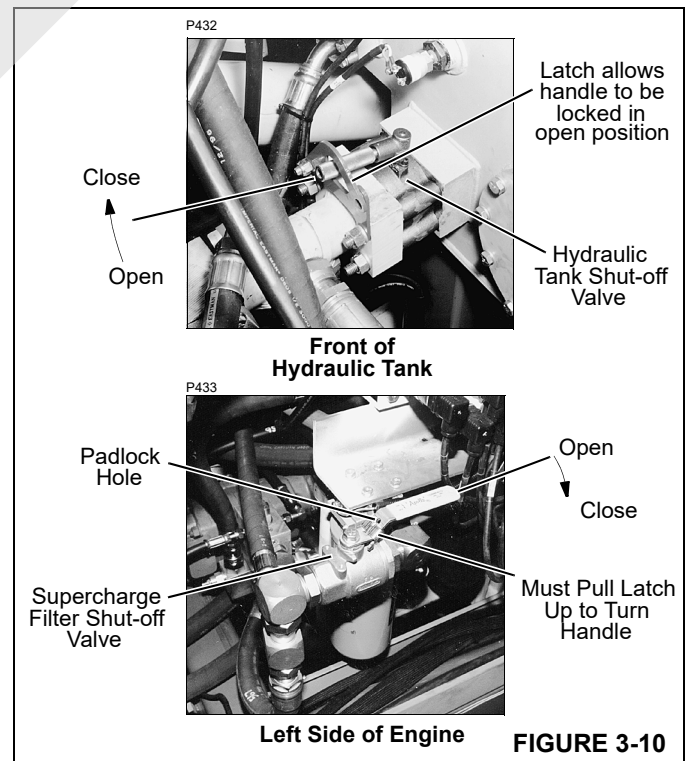

FIGURE 3-10

CAUTION

Pump Damage!

Do not start engine until hydraulic shut-off valves are open; otherwise, pumps could cavitate and be damaged.

3. Move cab power switch to ON. For QSC8.3 or QSL 340 engine *WAIT TO START* will appear on digital display indicating that pre-heaters are warming engine's air intake. Don't try to start engine until this line disappears from display (4-5 seconds).
4. Move engine run/stop switch to RUN.

NOTE: The operating limit alert and the system fault alert (lights, buzzer, beeper) should come on for three seconds when the run/stop switch is moved to run; if not, replace defective parts.

5. If ambient temperature is below 40°F (4°C), disengage engine clutch, as shown in Figure 3-11. This step will disconnect the pumps from the engine and aid in cold weather startup.

CAUTION

Engine Clutch Damage!

To maintain proper engine clutch operation:

- **Decrease engine speed to 1,300 rpm** before engaging or disengaging clutch.
- Do not run engine longer than 20 minutes with clutch disengaged.
- Disengage and engage clutch several times monthly with engine running.



WARNING

Explosion Hazard – QSC8.3 or QSL 340 Engine!

To avoid engine damage, do not use starting-aid fluids. This engine is equipped with an intake pre-heater. Using starting-aid fluids can cause an explosion and severe burns to personnel.

6. Turn ignition switch to START.

CAUTION

Starter Motor Damage!

If engine does not start after 30 seconds of cranking, wait a few minutes so starter motor cools before trying again

NOTE: A starting aid may be required when the outside air temperature is below 20°F (-7°C). See engine manual for cold weather starting instructions and safety precautions.

7. Increase engine speed as necessary to keep engine running after it starts. Allow engine to run until it begins to warm-up.
8. If disengaged, set engine speed at 1,300 rpm and **engage engine clutch slowly** to give engine time to take on added hydraulic load.

NOTE: It is normal for engine speed to droop as clutch is engaged (due to increased load of pumps and pump drive). If engine stalls, disconnect clutch and allow a longer warm-up period.

It is also normal for system fault alert and engine warning/diagnostic lights to come on after engine starts. Alert and lights should go off as engine oil pressure, hydraulic oil pressure, and hydraulic oil temperature rise to normal – if no other faults exist.

Once clutch is engaged (and engine remains running), decrease engine speed as low as

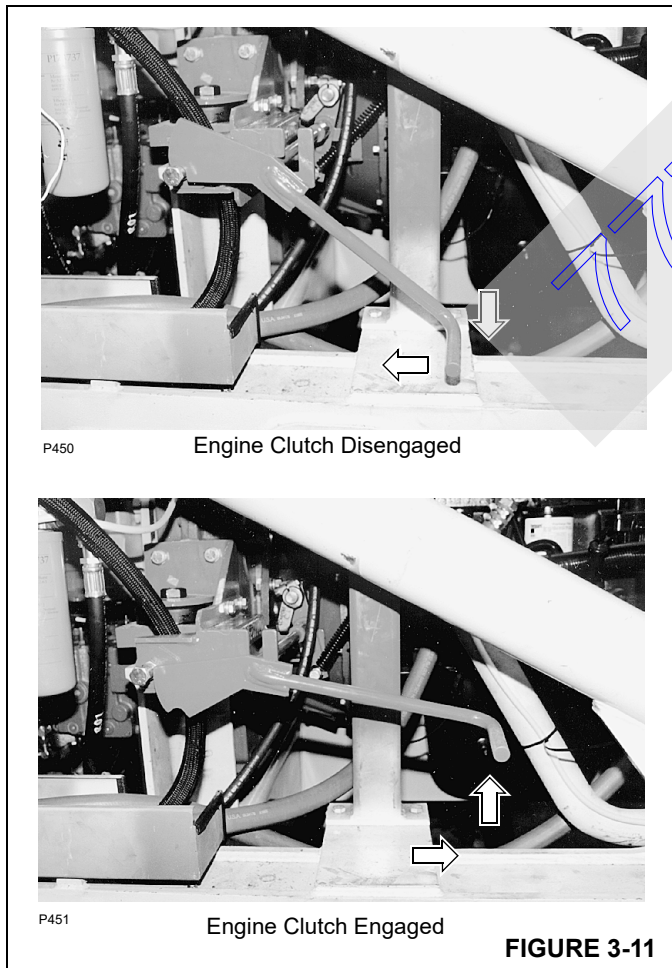

FIGURE 3-11

possible without stalling engine to **give system fault alert and engine warning/diagnostic lights time to turn off.**

- 9. Run engine at low idle until hydraulic oil temperature is at least 60°F (16°C) and **all faults are gone.**

CAUTION

Avoid Machinery Damage!

Do not operate crane when system fault alert is on. If alert does not go off soon after engine is started or comes on during operation, immediately proceed as follows:

- Determine fault on digital display.
- Land loads if possible. Otherwise apply drum pawls and brakes (if equipped with pedals) and park all functions.
- Move all control handles to off.
- Stop engine.
- Correct cause of fault.

- 10. Confirm crane mode in effect or select and confirm another crane mode. The drums and boom hoist are inoperable until this step is performed (operating limit alert will come on and CONFIRM MODE will appear on digital display if operation is attempted).

CAUTION

Machinery Damage!

Continuous operation with hydraulic oil temperature above 180°F (82°C) can result in damage to hydraulic components. Troubleshoot hydraulic system if oil temperature exceeds 180°F (82°C).

Engine Diagnostics

The Cummins QSC8.3 or QSL 340 Engine has two diagnostic modes:

- Offboard Diagnostics that requires Cummins Insite™ hardware and software, available from your local Cummins dealer.
- Onboard Diagnostics that uses warning lights to alert operator to engine problems during operation (engine running) and fault codes to identify specific problems when engine is not running.

Onboard Diagnostics

Engine Stop, Engine Warning, and Engine Maintain lights are mounted on front console in operator’s cab as shown in Figure 3-12.

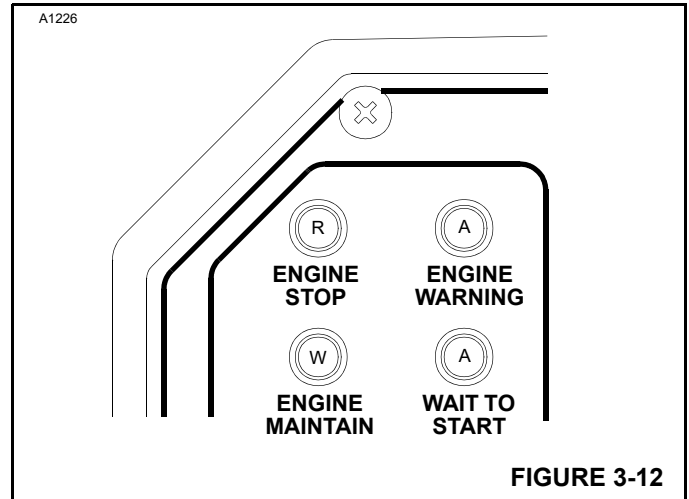

FIGURE 3-12

Engine Stop Light

When on, red Engine Stop light indicates need to **stop engine as soon as safely possible.**



WARNING

If possible, lower lifted loads and then stop engine as soon as possible when stop light comes on. Permanent damage can occur if engine is run while stop light is on. Do not run engine until fault is corrected.

Red Engine Stop light is also used with yellow Engine Warning light to flash out active fault codes when engine is off.

Engine Warning Light

When on, yellow Warning light indicates need to **repair fault at first available opportunity.**

Engine Maintain Light

When on, white Engine Maintain light indicates need to perform engine maintenance.

Engine Off Diagnostics

To identify active faults, proceed as follows. A laminated list of fault codes is located in the operator’s cab.

1. STOP engine.
2. Move key switch to RUN position.
3. Move hand throttle from low speed to high speed and back to low speed three times within five seconds.
4. If no active faults exist, WARNING and STOP lights come on but don’t flash.
5. If active faults exist, following occurs:

- a. Yellow WARNING light flashes indicating that a fault code is about to be flashed.
- b. There is a 1 to 2-second pause.
- c. Red STOP light flashes a three-digit code to show which active fault has been detected (refer to Figure 3-13 for example). There is a 1 to 2-second pause between each number.
- d. When code is finished flashing in red, there is a 1 to 2-second pause and yellow WARNING light flashes again.
- e. Same fault code flashes a second time before advancing to next code.

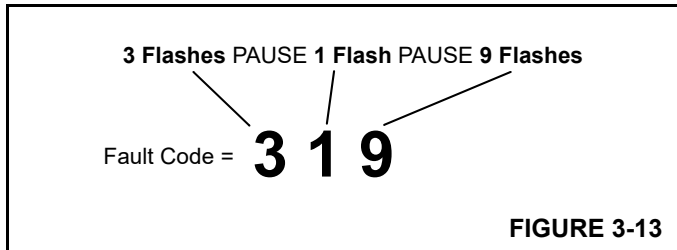

FIGURE 3-13

Boom Hoist Operation

1. Select and confirm desired mode (STANDARD, CLAM, DRAG).
2. If installed, disconnect the counterweight lifting pendants from the handling links, see Figure 3-20. Attach the pendants to the mast when not in use.
3. Turn on boom cylinder hold, if desired.

NOTE: When boom cylinder hold is on, the computer will stroke the boom hoist pump if required to maintain a “fixed cylinder position” when the boom hoist handle is off.

4. Increase engine speed to desired rpm with hand throttle. Press foot throttle to momentarily increase engine speed when more power is required.
5. Move boom hoist handle to FRONT from off to LOWER boom or to REAR from off to RAISE boom.

! WARNING

Two-Blocking Hazard!

Pay out load lines while lowering boom. Load may contact boom point or jib point sheaves if this step is not taken. Wire rope or other parts could break allowing load to fall.

6. As boom nears desired angle, slowly move boom hoist handle toward off to decrease speed. Then move handle to off to stop boom and hold it in position (holding valves will close).

NOTE: Besides being equipped with a boom up limit, a physical boom stop is provided. The physical boom stop cushions boom raising between approximately 78° and the up limit. Boom stop also provides a physical stop at 90°.

! WARNING

Falling Boom Hazard!

Operation with boom above up limit is not intended or approved. Boom could be pulled over backwards.

CAUTION

Fixed Jib Damage!

Avoid damage to fixed jib when lowering boom and jib to ground. Disconnect jib stop pendants or disengage jib stop pins before jib point contacts ground.

Boom Hoist Speed Adjustment

Boom Hoist Speed can be adjusted from 25% - 100% to suit operator needs.

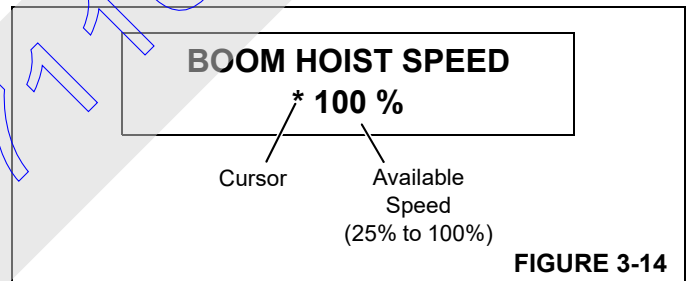

FIGURE 3-14

To adjust boom hoist speed, proceed as follows:

1. Stop booming.
2. Access boom hoist speed screen (Figure 3-14) by depressing limit bypass switch or turning key clockwise and scrolling up (with selector next to display screen). Once this step is performed, release switch or key any scroll up or down through diagnostic screens until boom hoist speed screen appears.
3. Rotate crane mode selector back-and-forth from center position to SELECT position until cursor (*) appears next to number on second line of screen.
4. Scroll up or down to change boom hoist speed to desired percentage between 25% and 100%.
5. Rotate crane mode selector back-and-forth from center position to SELECT position until cursor (*) disappears.
6. Adjustment is complete. The selected boom hoist speed will remain in computer memory, even after engine is stopped.

Luffing Hoist Operation



WARNING

Avoid Death or Serious Injury!

Read and understand instructions in Luffing Jib Operator's Manual before attempting to raise or lower luffing jib from or to ground.

Use extreme care when operating luffing hoist and boom hoist at same time. Maximum or minimum operating radius will be reached quickly when operating both hoists at same time.

CAUTION

Rigging Damage!

Avoid damage to luffing jib rigging. Check that luffing hoist wire rope is reeved through all sheaves and spooled properly onto rear drum before raising boom and jib from ground.

See Luffing Jib Rigging Drawing in Luffing Jib Operator's Manual for wire rope and reeving specifications. See Wire Rope Installation in Section 4 of this manual for instructions on attaching wire rope to rear drum.

1. Select and confirm LUFFING JIB mode.
2. If equipped, disable free fall for rear drum (see Disabling and Enabling Free Fall in this section).



WARNING

Falling Jib Hazard!

When equipped with a luffing jib, do not operate rear drum in FREE FALL mode. Luffing jib can lower uncontrolled if this precaution is not taken. To prevent free fall from being selected, disable free fall as instructed in Disabling Free Fall in this section.

3. Disengage rear drum pawl.
Luffing jib will not lower until pawl is disengaged. It may be necessary to raise luffing jib slightly before pawl will disengage.

CAUTION

Machinery Damage!

Do not engage rear drum pawl while lowering luffing jib. Damage to pawl or drum will occur.

Stop luffing hoist by moving rear drum handle to off and then engage rear drum pawl.

4. Increase engine speed to desired rpm with hand throttle. Press foot throttle to momentarily increase engine speed when more power is required.
5. Move rear drum handle to FRONT from off to LOWER luffing jib or to REAR from off to RAISE luffing jib.



WARNING

Two-Blocking Hazard!

Pay out load lines while lowering luffing jib. Load may contact luffing jib point sheaves if this step is not taken. Wire rope or other parts could break allowing load to fall.

6. As luffing jib nears desired angle, slowly move rear drum handle toward off to decrease speed. Then move handle to off to stop luffing jib and hold it in position (brake will apply).



WARNING

Falling Boom Hazard!

Operation with boom and/or luffing jib above up limits is not intended or approved. Boom and luffing jib could be pulled over backwards.

7. Engage rear drum pawl and turn on rear drum park once luffing jib is at desired angle.

CAUTION

Luffing Jib Damage!

Avoid damage to luffing jib when lowering boom and jib to ground. Disconnect jib stop pins before boom to luffing jib angle is 168° or jib stop pendants get tight, whichever occurs first.

Swing Operation



WARNING

Tipping Hazard!

Prevent crane from tipping; adhere to swing limitations given in capacity charts.



DANGER

Moving Crane Hazard!

Counterweights can strike personnel in area of swing path! Warn personnel to stay clear of swing path. Sound horn prior to swinging.

1. Turn off swing brake.
2. Disengage swing lock.

CAUTION

Swing Lock Damage!

Swing slightly in either direction so swing lock completely disengages ring gear before applying full swing power.

Do not engage swing lock while swinging; bring rotating bed to complete stop first.

3. Increase engine speed to desired rpm with hand throttle. Press foot throttle to momentarily increase engine speed when more power is required.
4. Move swing handle to LEFT from off to SWING LEFT or to RIGHT from off to SWING RIGHT.
5. Start swing motion with a smooth acceleration. Continue handle motion to swing at desired speed.
6. Stop swinging by releasing swing handle to off. Swing speed will decrease to off and rotating bed will coast to a stop. If a faster stop is desired, move swing handle slightly past off to opposite swing direction.

CAUTION

Boom/Swing Drive Damage!

Do not apply swing holding brake or turn on swing brake while swinging; brake will bring rotating bed to an abrupt stop. This action could cause damage to boom from side loading or damage to swing drive from shock loading. Bring rotating bed to smooth stop with swing handle and then apply swing holding brake or turn on swing brake.

7. Once rotating bed is stopped, apply swing holding brake to hold rotating bed in position for short periods during operating cycle.
8. To hold rotating bed in position for long periods, turn on swing brake and engage swing lock.

Swing Speed/Torque Adjustment

Swing speed and torque can be adjusted to suit operator needs.

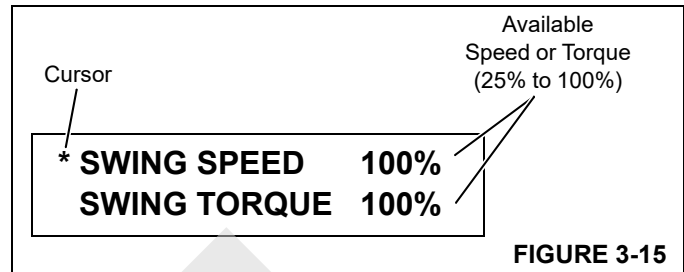

FIGURE 3-15

To adjust swing speed or swing torque, proceed as follows:

1. Stop swinging and apply swing parking brake (park upper with rocker on control console).
2. Access diagnostic screens (Figure 3-15):
 - a. Depress limit bypass button or turn limit bypass key clockwise and scroll up (with selector next to display screen).
 - a. Once step 2a is performed, scroll up at least one screen, release button or key, and scroll up or down through diagnostic screens until swing speed/swing torque screen appears.
3. Rotate crane mode selector back-and-forth from center position to SELECT position until cursor (*) appears next to SWING SPEED.

NOTE: When performing step 3 on past production 777s, use swing holding brake switch on swing lever (depress and release) instead of crane mode selector.

4. Scroll up and down to change swing speed to desired percentage between 25% and 100%.
5. Repeat steps 3 and 4 for SWING TORQUE.
6. Rotate crane mode selector back-and-forth from center position to SELECT position until cursor (*) disappears.

NOTE: When performing step 6 on past production 777s, use swing holding brake switch on swing lever (depress and release) instead of crane mode selector.

7. Adjustment is complete. The selected swing speed and torque will remain in computer memory, even after engine is stopped.

8. If desired, turn off diagnostic screens:
 - a. Depress limit bypass button or turn limit bypass key clockwise.
 - a. Once step 8a is performed, scroll down at least one screen and release button or key.

Stopping engine will also turn off diagnostic screens.

Load Drum Operation

There are three drive arrangements for the load drums:

- Standard Arrangement: one motor, planetary, disc brake and band brake on the right end of the drum.
- High Line Pull Arrangement (optional): one motor, planetary, disc brake and band brake on the right end of the drum and another motor, planetary, disc brake and band brake on the left end of the drum.
- High Line Speed Arrangement (optional): one motor, planetary, disc brake and band brake on the right end of the drum and another motor, planetary, disc brake (no band brake) on the left end of the drum.

NOTE: See Drum and Luffing Charts in Capacity Chart Manual for drum identification.



WARNING

Falling Load Hazard!

Prevent load on unused drum from falling. Engage drum pawl, apply drum brake with brake pedal (if equipped), and turn on drum park for drum not in use.

Liftcrane Operation — Full Power

NOTE: When a drum is not in free fall mode it operates in full-power.

1. Turn off free fall, if equipped, for drum to be operated.
2. Select and confirm desired crane mode. (STANDARD LUFFING JIB)
3. Disengage drum pawl for drum to be operated.

NOTE: The load will not lower until corresponding drum pawl is disengaged. It may be necessary to raise load slightly before pawl will disengage.

CAUTION

Machinery Damage!

Do not engage drum pawl while lowering a load. Damage to pawl or drum may result.

Stop drum with control handle or brake pedal (if equipped) and then engage drum pawl.

4. Release drum brake with brake pedal (if equipped) for drum to be operated.

NOTE: The brake pedal can be pressed down at any time to slow down or to stop the load.

5. Turn off drum park for drum to be operated.
6. Increase engine speed to desired rpm with hand throttle. Press foot throttle to momentarily increase engine speed when more power is required.
7. Move drum handle to REAR from off to RAISE load or to FRONT from off to LOWER load.
8. As load nears desired position, slowly move drum handle toward off to slow down load. Then release handle to off to stop load and hold it in position (drum brake will apply).

Liftcrane Operation — Free Fall

1. Fully apply drum working brake for drum to be operated in free fall.
2. Turn off drum park for drum to be operated in free fall.
3. Select and confirm FFALL ON mode for drum to be operated.

NOTE: The load drum will not switch to free fall until drum park is off and the selection and confirmation steps have been performed (see Crane Mode Selector for procedure).

4. Disengage drum pawl for drum to be operated.

NOTE: The load will not lower until corresponding drum pawl is disengaged. It may be necessary to hoist load slightly before pawl will disengage.

CAUTION

Machinery Damage!

Do not engage drum pawl while lowering a load. Damage to pawl or drum may result.

Stop drum with brake pedal and then engage drum pawl.

5. Increase engine speed to desired rpm with hand throttle. Press foot throttle to momentarily increase engine speed when more power is required.
6. Move drum handle to REAR from off and release drum brake with brake pedal to RAISE load with hydraulic power.
7. As load nears desired position, slowly move drum handle toward off to slow down load. Then fully apply

drum brake with brake pedal to stop load and release drum handle to off.



WARNING

Falling Load Hazard!

When operating in free fall, load will lower uncontrolled if drum brake is not applied with brake pedal when drum handle is released to off.

Be ready to apply drum brake so lowering speed can be controlled and load can be stopped immediately when necessary.

8. To lower load, leave drum handle in off and release drum brake with brake pedal to lower load at desired speed.

As load nears desired position, slowly apply drum brake to slow down load. Then fully apply brake to stop load and to hold it in position.

NOTE: There is no power lowering feature in free fall. *If a drum handle is moved forward from off while free falling a load, corresponding band brake will apply.*

CAUTION

Machinery/Boom Damage!

While free falling a load:

- Do not move drum handle in either direction from off.
- Do not turn off free fall.
- Do not turn on drum park.

Shock load damage to machinery or boom can result. Bring drum to a complete stop with brake pedal before performing above operations.

9. If load will be suspended for any length of time, fully press and latch brake pedal in applied position, turn on drum park, and engage drum pawl.

Clamshell Operation

Preparing for Clam Operation

1. Turn off free fall for both drums. The drums will operate in full-power.
2. Select and confirm CLAMSHELL mode.
3. Disengage drum pawl for both drums.
4. Set engine speed at desired rpm.
5. Adjust clam closing pressure as follows:
 - a. Raise bucket off ground.
 - b. Unlock, press and hold limit bypass switch.

- c. Press digital display selector to set closing line pressure. The CLAM CLOSING PRESS screen will automatically appear on the digital display.

Press top end of display selector (scroll up) to increase pressure; press bottom end of display selector (scroll down) to decrease pressure.

With the bucket raised off the ground (on holding line) at the start of the clam cycle, adjust clam closing pressure so bucket fully closes and just starts to rise on closing line.

Readjust pressure as required while digging so bucket fully closes without rising on closing line.

NOTE: The clam closing pressure selected will remain in computer memory even after engine is stopped.

Bucket size, parts of line, and type of material being handled govern clam closing pressure required. It may be necessary to readjust clam closing pressure if any of these factors change.

Operating Clamshell In Full-Power

Perform steps described in Preparing for Clam Operation. Then proceed as follows:

Closing Bucket (Digging)

1. Lower bucket into digging area.
2. Pull back closing line handle to close bucket. The holding line will pay out automatically allowing the bucket to dig in as it closes.
3. Release closing line handle to off when bucket is closed fully.

NOTE: Watch closing line when digging in a blind area. Bucket is closed when closing line stops moving (if clam closing pressure is properly adjusted).

Raising Bucket

1. Pull holding line handle back to raise bucket at desired speed.
2. Swing to dumping area as bucket rises.
3. Release holding line handle to off when bucket is at desired height.

Dumping Bucket

1. Push closing line handle forward to dump bucket at desired speed.
2. Release closing line handle to off as soon as bucket is empty and fully open.

Use care not to slacken closing line while dumping. Any slack in closing line will have to be taken out while digging. This action will slow down clam cycle.

Lowering Bucket

1. Push holding line handle forward to lower bucket at desired speed.
2. Control lowering speed by slowly moving holding line handle toward off.

NOTE: Lowering speed is controlled by handle movement. It is not necessary to apply the drum brakes with the brake pedals to slow down the bucket when operating in full-power.

3. Swing back to digging area as bucket lowers.
4. Stop swinging when bucket lands in digging area.
5. Bucket will stop lowering automatically when it contacts ground.
6. Release holding line handle to off.
7. Repeat clam cycle.

Travel Operation

WARNING Tipping Hazard!

Travel surface must be firm and uniformly supporting.

For *traveling with load*, grade must not exceed 1% in any direction.

For *traveling without load*, grade in direction of travel must not exceed 30%; grade from side to side must not exceed 2%, measured at boom hinge pins. For all travel on grades, see Maximum Allowable Travel Specifications chart.

Failing to comply with above specifications can result in tipping.

1. Before traveling:
 - a. Plan travel route. It must be free of ground and overhead constructions.
 - b. Check crawlers for proper adjustment.
 - c. Warn personnel to stand clear of travel area. *Do not travel without a signal person.*
2. Position boom at or above boom angle given on capacity chart when *traveling with load*.
3. Travel with boom in-line with crawlers except when swinging is necessary while traveling. Travel with boom facing direction of travel.
4. For *traveling with load*, carry load as close to ground as possible; stabilize load with taglines.

For *traveling without load*, carry load block and weight ball low enough that they cannot swing into boom or jib. If desired, tie off load block at front of rotating bed.

5. Increase engine speed to desired rpm with hand throttle. Press foot throttle to momentarily increase engine speed when more power is required.
6. Select desired travel speed, low or high.

WARNING

Moving Crane Hazard!

Know position of crawler drive shafts before traveling. An accident can result if crane travels opposite of intended direction.

CAUTION

Boom Damage!

Avoid shock loading boom and rigging!

Perform all travel functions — starting, turning, stopping — slowly and smoothly.

Crawler Damage!

Avoid damage to crawler components (treads, rollers, frames).

Use care to prevent dirt from piling up at tumbler and front roller ends of crawlers when turning on soft surfaces:

- Bring crawlers to a complete stop before changing travel direction.
- Turn a few degrees. Then slowly travel forward or reverse so dirt falls away from crawlers. Continue this procedure until desired turn has been made.
- Avoid sharp turns (Figure 3-17) if possible.
- Make gradual turns (Figure 3-18) or counter-rotate (Figure 3-19) whenever possible so both crawlers are always powered.
- Clean crawlers often.
- Keep crawler treads properly adjusted.

WARNING

Flying Object Hazard!

Excessive dirt build-up at tumbler and front roller ends of crawlers can result in excessive tension in tread connectors. Tread connectors can break if over tensioned, causing treads to fly apart unexpectedly with dangerous force.

NOTE: The following directions of travel are with *crawler drive shafts to rear of operator*. If the drive shafts

are to the front, the crane will travel in the direction opposite of handle movement.

- To TRAVEL STRAIGHT (Figure 3-16), move both crawler handles/pedals same amount in desired direction from off.

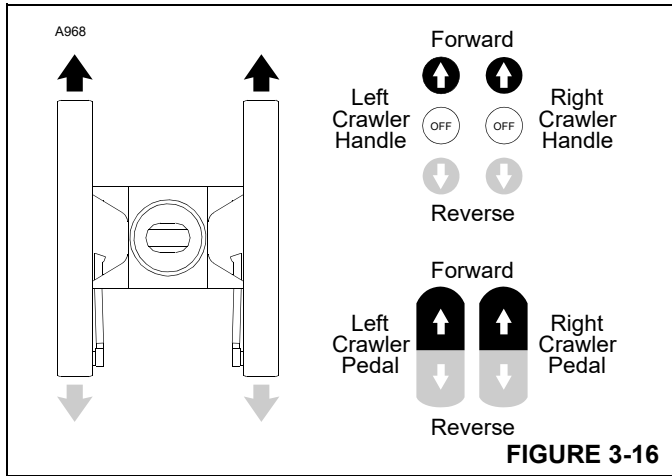

- To make a SHARP LEFT TURN (Figure 3-17), move right crawler handle/pedal to front from off and leave left crawler handle/pedal in off; crane will pivot about left crawler.

- To make a SHARP RIGHT TURN, reverse step 8.

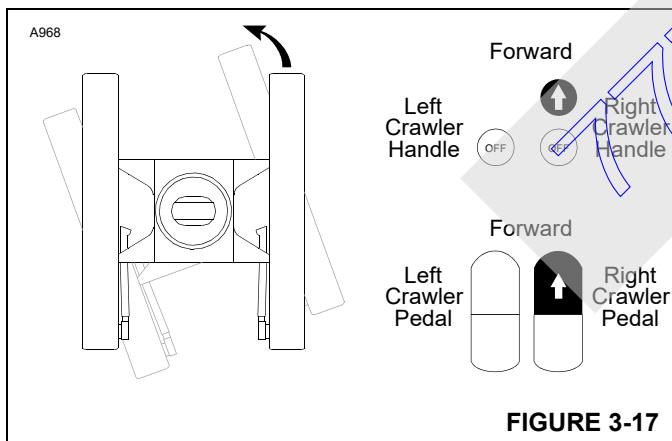

- To make a GRADUAL LEFT TURN (Figure 3-18), move both crawler handles/pedals to front from off, but move

right crawler handle/pedal farther to front than left crawler handle/pedal; right crawler will turn faster than left crawler.

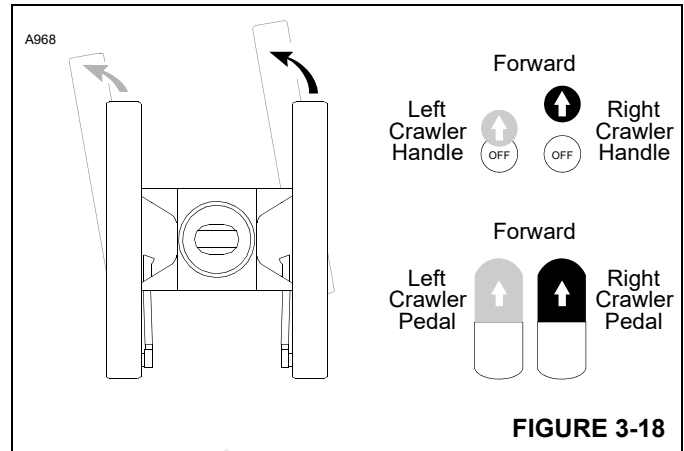

- To make a GRADUAL RIGHT TURN, reverse step 10.

- To COUNTER-ROTATE LEFT (Figure 3-19), move right crawler handle/pedal to front from off and move left crawler handle/pedal to rear from off.

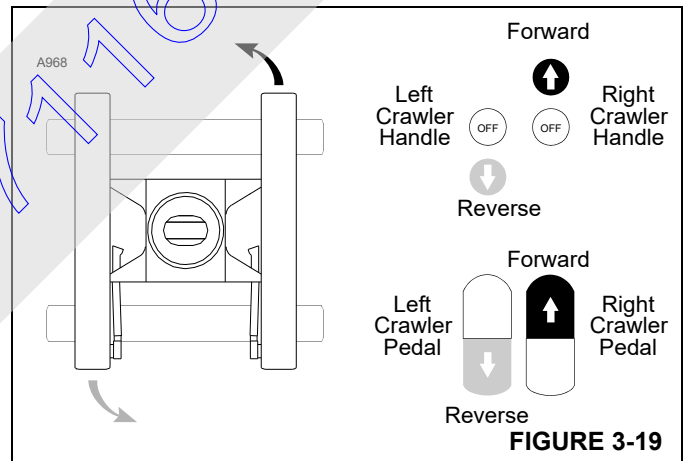

- To COUNTER-ROTATE RIGHT, reverse step 12.

- Slowly move both crawler handles/pedals to off to stop traveling and to hold crane in position.

- Turn on travel park.

Stopping Engine/Leaving Crane Unattended



WARNING

Moving Load/Tipping Crane Hazard!

Operator shall not leave operator's cab until crane, loads, and boom have been secured against movement.

Changing weather conditions including but not limited to: wind, ice or snow accumulation, precipitation, flooding, lightning, etc. should be considered when determining the location and configuration of a crane when it will be left unattended.

1. Travel crane onto a level surface; *do not leave crane unattended on a grade.*
2. Turn on travel park.
3. Swing rotating bed to desired position. Then engage swing lock and turn on swing brake.
4. Lower all loads to ground and fully apply drum brakes with brake pedals and latch pedals down (if equipped).
5. Turn on drum park for each drum.
6. Engage drum pawls.
7. If the crane will be unattended for only a short length of time, turn on boom hoist park.

When the crane is parked overnight or for any other extended length of time, the boom might lower on its own due to internal leakage or heat expansion. Naturally, this is a safety hazard if the boom lowers too far.

To prevent this problem, the boom must be parked as shown in Figure 3-20. To secure the boom, follow these instructions:

- a. Raise boom to approximately 75°.
- b. Disconnect counterweight lifting pendants from stored position on mast and pin to handling links.
- c. Lower boom until pendants just start to go into tension and stop (counterweight maximum up limit should come if you go too far).

Pendants will hold boom between 67° and 73° depending on boom length.

- d. Turn on boom hoist park.
- e. Reverse procedure to return to normal operation.

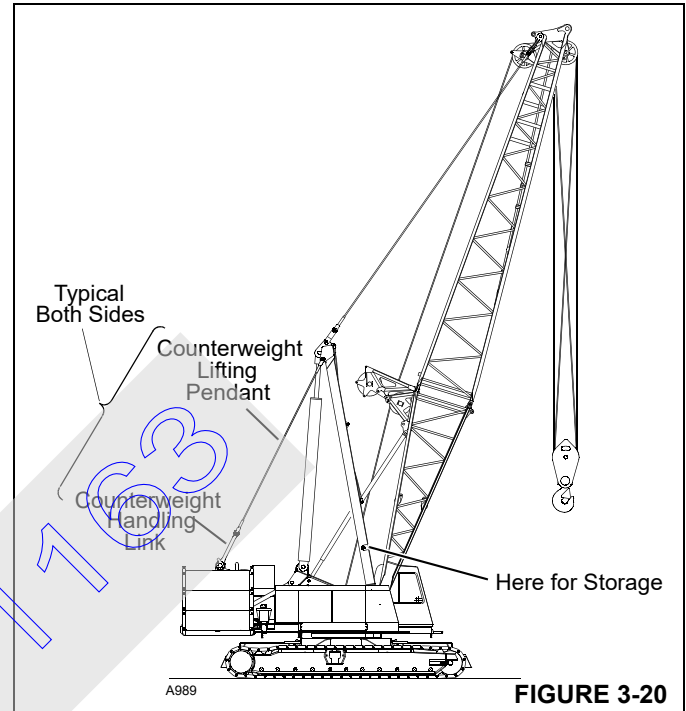

8. Turn off boom cylinder hold.
9. Check that all handles are off.
10. Decrease engine speed to low idle.
Allow engine to idle for three to five minutes so it cools evenly.
11. Stop engine.
12. Turn off cab power switch.
13. Remove all keys (cab power and crane mode) to *prevent unauthorized operation.*
14. Lock operator's cab windows and door to *prevent unauthorized entry.*

FUSES

Fuse Location

Fuses are located in the front of the left enclosure (Figure 3-3).

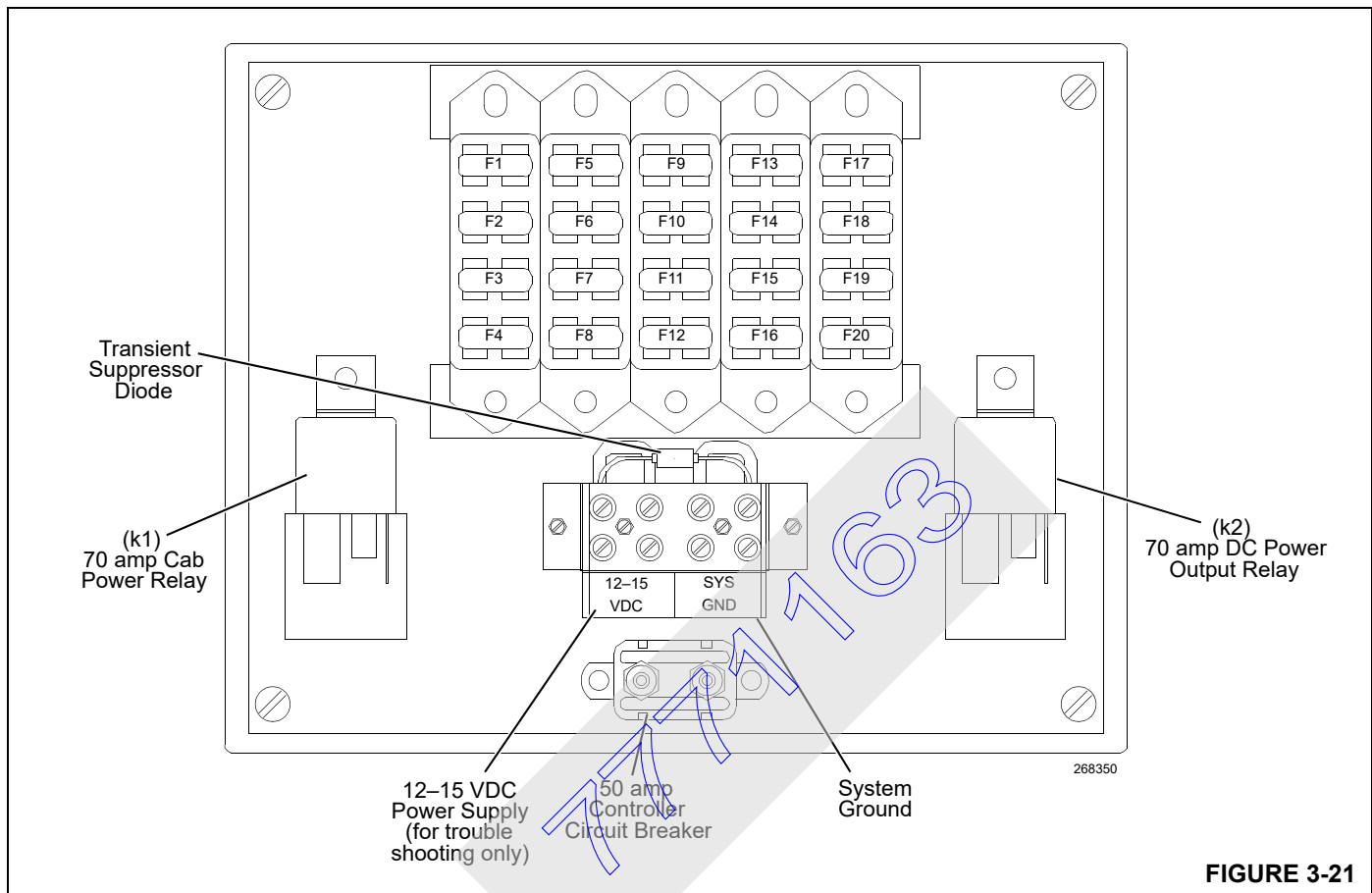

FIGURE 3-21

Fuse Identification

Fuse Number	Description	Fuse Number	Description
F1	Cab Heater (8H) 15 amp	F11	Spare 10 amp
F2	Front Wiper (8W1) 10 amp	F12	10 VDC Reg. Supply (87FA) 3 amp
F3	Overhead Wiper (8W2) 10 amp	F13	Heater Fan/Hi-Speed (5A) 20 amp
F4	Spare 20 amp	F14	Lights/Accessories (5A) 20 amp
F5	Spare 15 amp	F15	Horn (5H) 20 amp
F6	Swing/Pawls (8S) 15 amp	F16	Engine/Dome Light (5D) 10 amp
F7	Defogger Fan (8F) 10 amp	F17	20 amp
F8	Gauges/Load Cells (8A) 10 amp	F18	15 amp
F9	Sensor Inputs (8D) 10 amp	F19	10 amp
F10	Transducers/Encoders (8T) 10 amp	F20	3 amp

VOLTMETER OPERATION

Engine not running or running at low idle.

Engine running fast enough to make alternator produce.

?
Dead or disconnected battery. Disconnected or badly connected meter.

A915

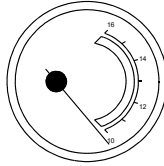

?
Disconnected meter. Engine could not run with dead or disconnected battery unless circuit was completed around battery.

?
Very low battery charge. Engine might not start.

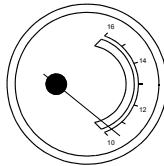

??
When pointer stays below 13.3V with engine running fast enough to operate alternator, it shows that alternator is not operating, voltage regulator is out of adjustment, or current being drawn from battery by lights, heater, fan, or other load exceeds alternator output.

?
Low battery charge. Constant reading in this area indicates need to check alternator and voltage regulator.

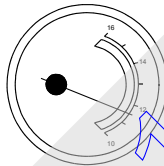

?
Well-charged battery. Indicates a good battery and that alternator and voltage regulator are operating properly.

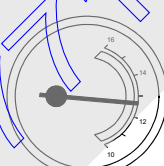

??
When engine is started, pointer might stay in this area temporarily, but it should gradually rise above 13.3V as alternator reaches normal output.

?
Pointer might remain in this position temporarily when engine has been stopped after considerable use, due to a "surface charge" in battery. To get a correct reading, turn on wipers or heater for a few minutes.

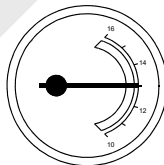

??
Under normal conditions, a 12V battery is fully charged at 12.8V. A slightly higher reading might occur under conditions outline in No. 5; generally speaking, however, any reading above 12.8V when engine is stopped is not a true reading.

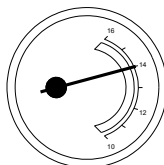

?
This is area where pointer should be when alternator, voltage regulator, and battery are all in good condition and working properly.

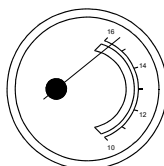

?
When pointer goes above 15.2V, voltage regulator is set too high or jammed; continued operation of engine will burn out battery.

DISABLING AND ENABLING FREE FALL

Quick-disconnect couplers in hydraulic hoses to drum clutch solenoid valves allow FREE FALL operation to be disabled at either or both drum clutches.

When equipped with a luffing jib and free fall on the rear drum, **free fall must be disabled so the luffing jib cannot lower uncontrolled.**



DANGER Falling Jib Hazard!

When equipped with a luffing jib, do not operate rear drum in FREE FALL mode. Luffing jib can lower uncontrolled if this precaution is not taken. To prevent free fall from being selected, disable free fall as instructed in this topic.

Disabling Free Fall

Perform the following steps to disable free fall operation for either or both load drums (Figure 3-22):

1. **Stop engine.**
2. For FRONT DRUM:
 - a. Disconnect clutch hose (F, View A or C) from coupler (F1) at clutch solenoid valve.
 - b. Connect clutch hose (F, View A or C) to coupler (F2) in tank return line.
3. For REAR DRUM:
 - a. Disconnect clutch hose (R, View B or C) from coupler (R1) at clutch solenoid valve.
 - b. Connect clutch hose (R, View B or C) to coupler (R2) in tank return line.

- c. **Install dust caps to keep unused couplers clean.**



WARNING

Falling Load or Jib Hazard!

To prevent load or luffing jib from falling:

- Always stop engine before disconnecting and connecting drum clutch hydraulic hoses.
- Do not operate crane unless drum clutch hydraulic hoses are connected either to couplers at solenoid valve or to couplers in tank return line.

Faulty clutch operation can occur if these precautions are ignored. Load or luffing jib could fall.

Enabling Free Fall

Perform the following steps to enable free fall operation for either or both load drums (Figure 3-22):

1. **Stop engine.**
2. For FRONT DRUM:
 - a. Disconnect clutch hose (F, View A or C) from coupler (F2) in tank return line.
 - b. Connect clutch hose (F, View A or C) to coupler (F1) at clutch solenoid valve.
3. For REAR DRUM:
 - a. Disconnect clutch hose (R, View B or C) from coupler (R2) in tank return line
 - b. Connect clutch hose (R, View B or C) to coupler (R1) at clutch solenoid valve.
 - c. **Install dust caps to keep unused couplers clean.**

A1058

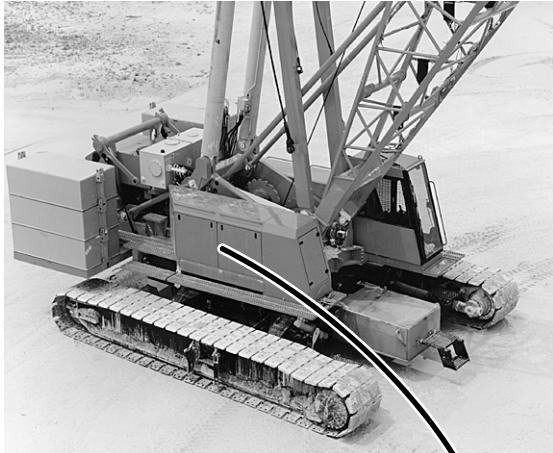

P568

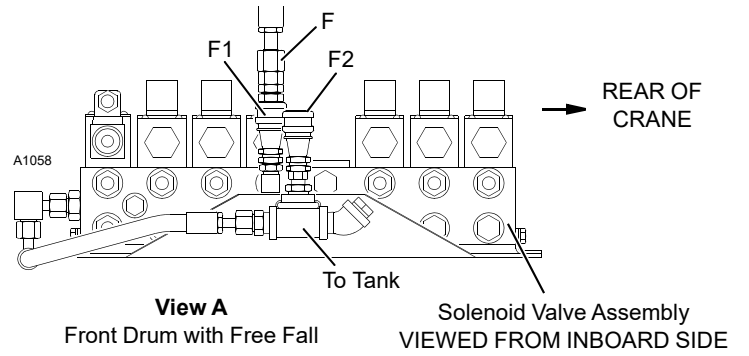

PAST PRODUCTION

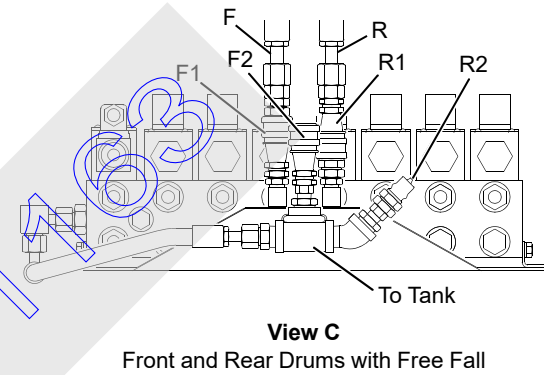
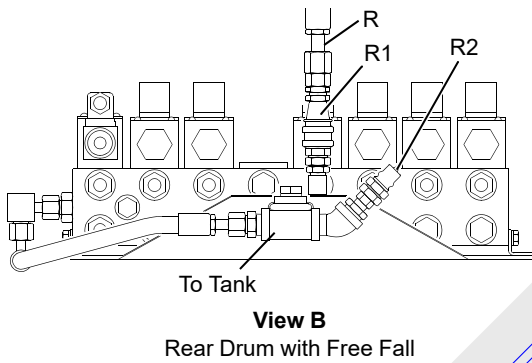

3

A1103

CURRENT PRODUCTION

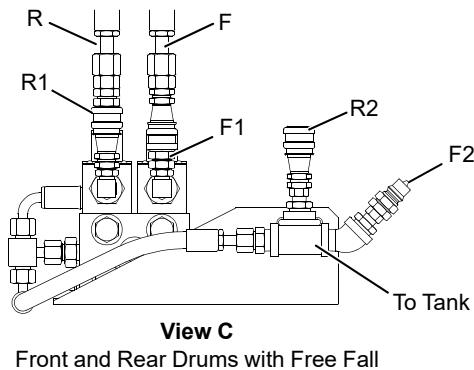
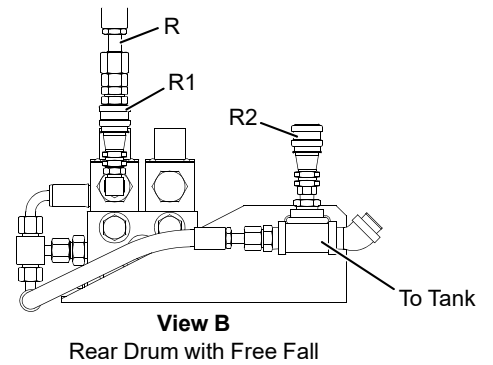
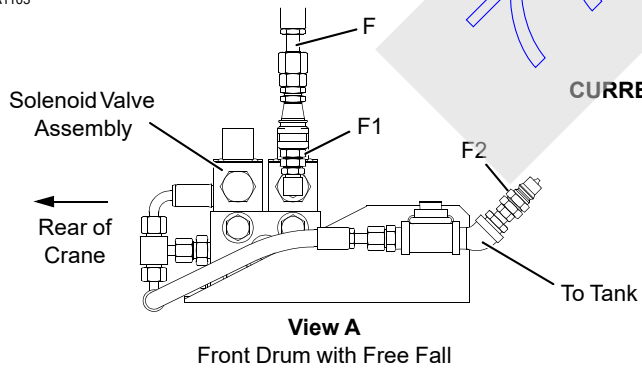

FIGURE 3-22

THIS PAGE INTENTIONALLY LEFT BLANK

777163

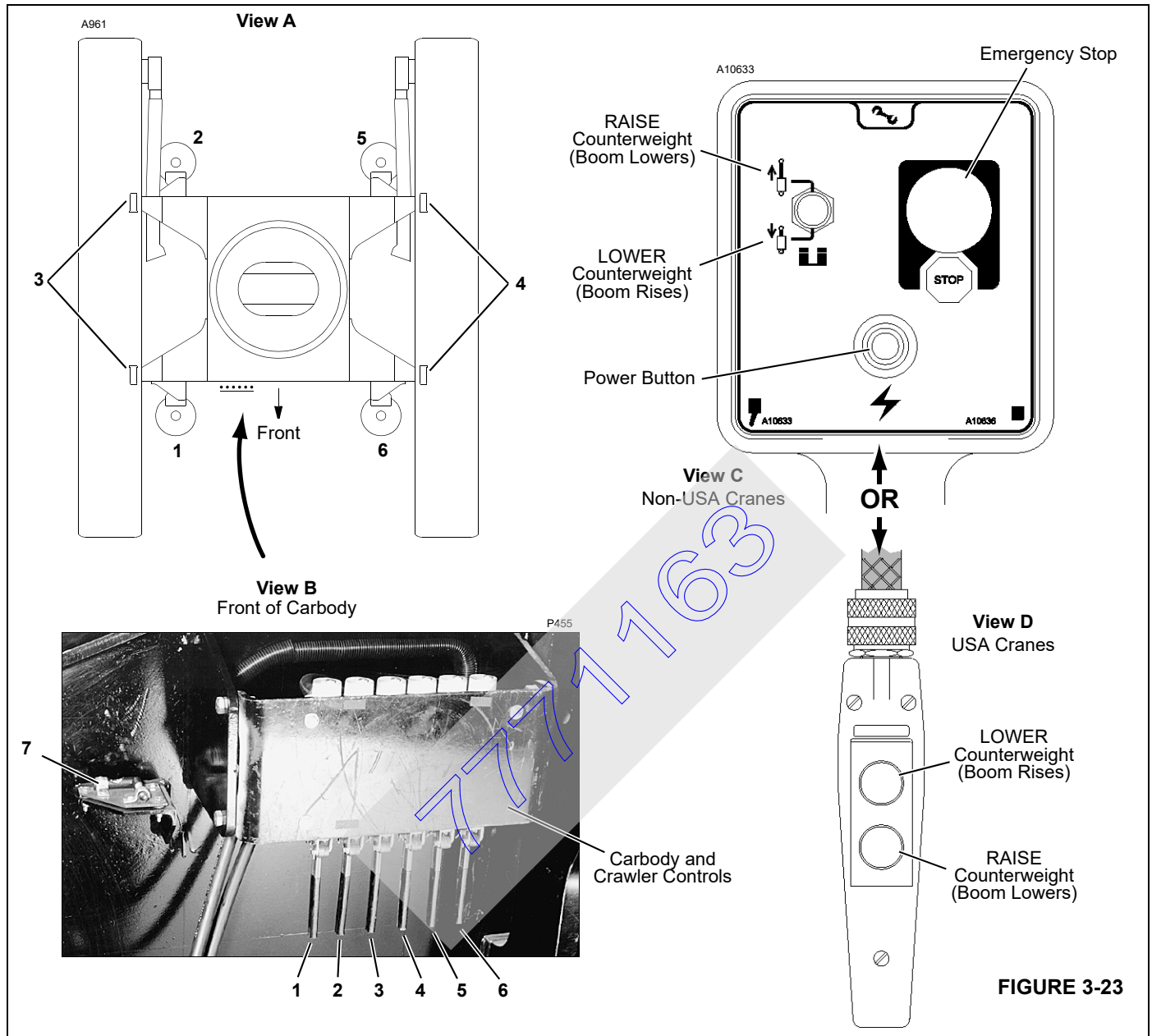

FIGURE 3-23

REMOTE CONTROLS

This topic identifies and describes operation of the remote controls used for crane assembly and disassembly.

! WARNING

Read Instructions!

Avoid death or serious injury to personnel and damage to crane:

- Read assembly and rigging procedures in this manual before operating remote controls.

NOTE: RIGHT, LEFT, FRONT, and REAR used in this section correspond to operator's right, left, front, and rear sides when seated in operator's cab with crawler drive shafts to rear.

Speed of operations depends on control handle movement and/or engine speed.

All control handles are spring returned to off.

Controls Identification and Operation

Carbody Jack Controls

- 1 – Carbody Jack Control (right front)
- 2 – Carbody Jack Control (right rear)
- 5 – Carbody Jack Control (left rear)
- 6 – Carbody Jack Control (left front)

See Figure 3-23, Views A and B for location of carbody jacks and controls.

Pull handle AWAY from carbody to RAISE carbody (extend jack).

Release handle to CENTER to stop jack. Valves on the jack lock it in position.

Push handle TOWARD carbody to LOWER carbody (retract jack).

WARNING Tipping Hazard!

Prevent crane from tipping over.

- Keep crane level while jacking.

Moving Part Hazard!

Avoid serious injury:

- Keep feet clear of moving jacks.
- Warn all personnel to stay clear of jacks while they are being extended.

CAUTION Machinery Damage!

Avoid damage to carbody jacks:

- Fully retract jacks before traveling.

7 – Carbody Level

See Figure 3-23, View C for location of the level.

Indicates crane levelness from front to rear and from side to side while jacking carbody as shown in Figure 3-23.

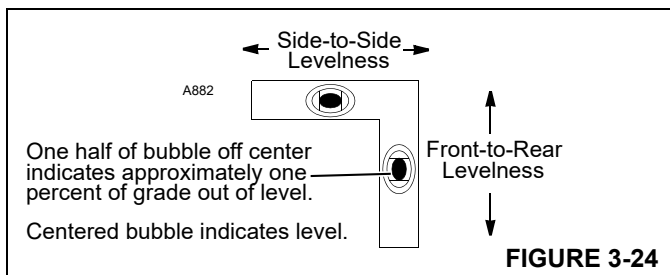

Crawler Pin Controls

- 3 – Crawler Pins Control (right crawler)
- 4 – Crawler Pins Control (left crawler)

See Figure 3-23, Views A and B for location of crawler pins and controls.

Pull handle AWAY from carbody to ENGAGE crawler connecting pins. Crawler locking pins and collars must be installed to lock connecting pins in the engaged position (see Install Crawlers in Section 4 of this manual).

Release handle to CENTER to stop pins.

Push handle TOWARD carbody to DISENGAGE crawler connecting pins. Crawler locking pins and collars must be removed before connecting pins can be disengaged (see Install Crawlers in Section 4 of this manual).

Counterweight Remote Control

NOTE: The SETUP mode must be selected and confirmed to operate counterweight remote control. When SETUP mode is selected and confirmed, boom hoist control in cab is still operable. Operation of counterweight remote control overrides boom hoist control in cab.

On Crane S/N 7771165:

- The swing and travel alarm will sound continuously when a function is being operated from the counterweight remote control. If you attempt to operate a crane function in cab while counterweight remote is being operated, the REMOTE ACTIVE fault will appear on the digital display system fault screen. The control in the cab will be disabled.

Remove the remote control from storage in left front enclosure.

Emergency Stop Push Button (Non-USA Cranes)

PUSH to LATCH. All setup functions stop immediately. TURN to RELEASE. Push button must be released before counterweight switch is enabled.

Counterweight Switches

Non-USA Cranes (Figure 3-23, View C):

Press power button and move toggle up and hold to RAISE counterweight (lower boom).

Press bottom button and move toggle down and hold to LOWER counterweight (raise boom).

USA Cranes (Figure 3-23, View D):

Press top button to LOWER counterweight (raise boom).

Press bottom button to RAISE counterweight (lower boom).

PROGRAMMABLE CONTROLLER CALIBRATION PROCEDURES

General

To ensure proper operation of the crane functions, the controls and pressure senders must be properly calibrated as described below.

Controls Calibration

The controls must be calibrated at the following intervals:

- When a pump is replaced.
- When a pump control (EDC or PCP) is replaced.
- When a boom hoist cylinder is replaced.
- When a new programmable controller is installed.
- When a new CPU board is installed.
- When a new controller chip is installed.
- When there is a noticeable increase in the time it takes a crane function to engage when the handle is pulled back from off.
- Every 6 months.

To calibrate the controls, proceed as follows:

To calibrate the controls, proceed as follows:

1. Engage swing lock.
2. Calibrate pressure senders.
3. Start and run engine at:
 - 1,900 rpm or higher for past production units (Tier 1 engine).
 - 1,600 rpm or higher for current production units (Tier 2 and 3 engine).
4. Depress and hold swing holding brake switch (on swing handle) for ONE MINUTE.
5. Repeat steps 3 and 4 a second time.

Pressure Sender Calibration

The pressure senders must be calibrated (zeroed) at the following intervals:

- When a new programmable controller is installed.
- When a new CPU board is installed.
- When a new controller chip is installed.
- When a pressure sender is replaced (see Pressure Sender Replacement in Section 2 of Service Manual).
- When displayed pressure is wrong.
- Every 6 months.

To calibrate the pressure senders, proceed as follows:

1. Stop engine.
2. Turn ON cab power switch.
3. Turn crane mode selector key counterclockwise to CONFIRM position and hold.
4. Press engine run/stop switch to RUN position.
5. Continue to hold crane mode selector key in CONFIRM position for ONE MINUTE after performing step 4.
6. Confirm that pressure senders are properly calibrated by checking charge pressure on diagnostic screens of digital display (refer to Diagnostic Display publication in Operator's Manual):
 - a. With engine off (key in RUN), charge pressure for each crane function should be 50 psi (3.4 bar) or less.
 - b. With engine running, charge pressure for each crane function should be within normal operating range (approximately 275 (19.0 bar) at low idle to 400 psi (27.6 bar) at high idle).

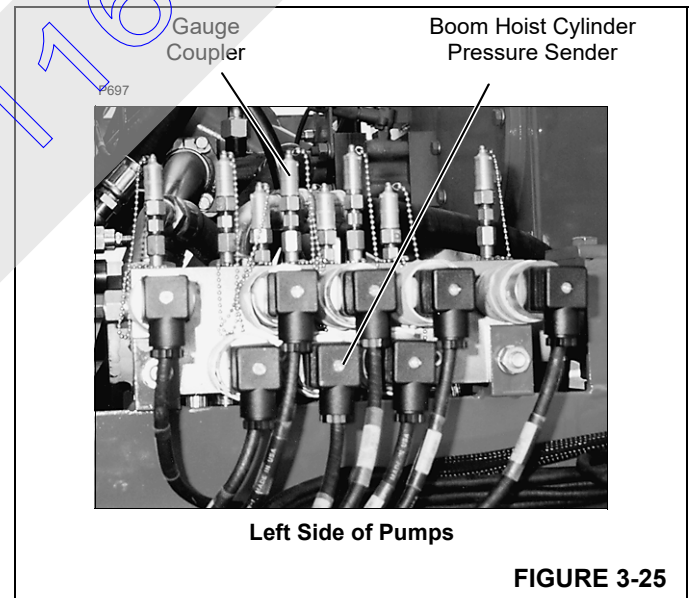

DIGITAL DISPLAY READINGS

The digital display and selector (see Operating Controls in this section) allow operator to monitor three groups of crane information: operating conditions, operating limits, and system faults.

Depress top or bottom of selector to scroll up and down through the display readings. Release selector when desired information is displayed.

To display diagnostic operating conditions listed in Table 3-4, depress limit bypass switch while scrolling up with selector.

See Table 3-7 for a list of abbreviations used and Table 3-8 for drum identification.

Operating Conditions

Table 3-4 lists operating conditions which can be displayed and the normal operating range of each.

When an operating condition is selected (such as ENGINE SPEED), the current status of the condition displays (see Figure 3-26).



FIGURE 3-26

Operating Limits

Table 3-5 lists operating limits which can be displayed.

When one or more operating limits is reached, the operating limit alert (yellow light and buzzer in cab) turns on to warn the operator. At the same time, the operating limit display immediately appears (see Figure 3-27) and automatically scrolls through the names of the limits, stopping at each for approximately three seconds.



FIGURE 3-27

The operating limit alert turns off when the cause of each limit is corrected. The name of each limit reached during operation is retained in memory, however, *until two things happen*:

1. Name of limit appears on display at least once.
2. Cause of limit is corrected.

For this reason, it is normal for the names of limits to appear when you scroll to the operating limit group, even when operating limit alert is off.

To erase names of inactive limits, scroll to operating limit group. Wait until display scrolls through the name of each limit. The names of inactive limits will be erased automatically. If the alert is on, only the names of active limits will remain.

NO FAULT appears on the display (see Figure 3-28) when no limits have been reached.



FIGURE 3-28

System Faults

Table 3-6 lists system faults which can be displayed.

When one or more system faults occur, the system fault alert (red light and beeper in cab) turns on to warn the operator. At the same time, the system fault display immediately appears (see Figure 3-29) and automatically scrolls through the names of the faults, stopping at each for approximately three seconds.

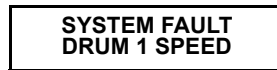

FIGURE 3-29

The system fault alert turns off when the cause of each fault is corrected. The name of each fault that has occurred during operation is retained in memory, however, *until two things happen*:

1. Name of fault appears on display at least once.
2. Cause of fault is corrected.

For this reason, it is normal for the names of faults to appear when you scroll to the system fault group, even when system fault alert is off.

To erase names of inactive faults, scroll to system fault group. Wait until the display scrolls through the name of each fault. The names of inactive faults will be erased automatically. If the alert is on, only the names of active faults will remain.

NO FAULT appears on the display (see Figure 3-30) when there are no faults.

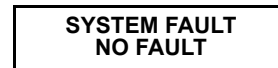

FIGURE 3-30

Selecting Display Language

The display can be viewed in English or one of several other languages. Once the desired language is selected, it will remain in memory until another language is selected.

To select a different display language, perform both of the following steps at the same time:

1. Depress limit bypass switch.
2. Turn crane mode selector key to “confirm” position.

Repeat the steps until the screen displays the desired language.

**Table 3-4
Operating Conditions**

Listed below are the operating conditions which can be viewed on the digital display.

Display Reading	Unit of Measure	Operating Range
Normal Operating Conditions		
The operating conditions listed below are displayed by scrolling up or down with the digital display selector.		
ENGINE SPEED	RPM	Low idle and high idle settings are determined by engine manufacturer.
BOOM ANGLE	DEG	Degrees boom is positioned above horizontal [1].
LUFFING JIB ANGLE [2]	DEG	Degrees luffing jib is positioned above horizontal [1].
BOOM TO LUFF JIB ANG [2]	DEG	Degrees between centerline of boom and centerline of luffing jib.
CLAM CLOSING PRESS	PSI	See Clamshell Operation instructions in this section for procedure to adjust pressure.
CRANE MODE (name of mode)	—	See Crane Mode Selector instructions in this section for procedure to select and confirm desired crane mode.
Diagnostic Screens		
Operating conditions listed below are displayed only by depressing limit bypass switch and scrolling up with digital display selector. To turn off diagnostic screens, depress limit bypass switch and scroll down or stop and restart engine.		
A1	2 Rows of numbers	These numbers are used to monitor and troubleshoot controls and hydraulic systems. See Diagnostics Display in this section for explanation of these screens.
A2		
A3		
D1		
D2		
D3		
DRUM 1		
DRUM 2		
DRUM 8 [2]		
BHST		
SWING		
TRACK		
PROGRAM M000000.0FP	—	Computer Program Version. <i>Factory service personnel will request these numbers when troubleshooting crane problems.</i>
CON 00000000000	—	Computer and Crane Configuration Code. <i>Factory service personnel will request these numbers when troubleshooting crane problems.</i>

[1] Boom angle and luffing jib angle are displayed at same time.

[2] Optional Item.



Table 3-5
Operating Limits

Listed below are limits which turn on the operating limit alert (yellow light and continuous buzzer). When the alert comes on, OPERATING LIMIT group of digital display will indicate which limit has been reached; take corrective action.

Display Reading	Function Response	Corrective Action
BLOCK UP	Load drums stop hoisting and boom or jib hoist stops lowering.	Lower corresponding load or raise boom or jib.
BOOM MAXIMUM DOWN	Boom stops lowering [3].	Raise boom.
BOOM MAXIMUM UP	Boom stops rising [3].	Lower boom.
CONFIRM MODE	All drums inoperable until an operating mode is selected and confirmed.	Select and confirm the desired operating mode (see Operating Controls for procedure).
DRUM 1 MAXIMUM BAIL [2]	Drum stops hoisting.	Operate drum in lowering direction.
DRUM 2 MAXIMUM BAIL [2]		
DRUM 8 MAXIMUM BAIL [2]		
DRUM 1 MINIMUM BAIL [2]	Drum stops lowering.	Operate drum in hoisting direction.
DRUM 2 MINIMUM BAIL [2]		
DRUM 8 MINIMUM BAIL [2]		
DRUM 1 PAWL IN	Drum doesn't lower or stops lowering.	Disengage pawl. It may be necessary to hoist slightly before pawl will disengage.
DRUM 2 PAWL IN		
DRUM 8 PAWL IN [2]		
COUNTERWEIGHT MAX UP	Boom hoist inoperable in lowering direction.	Disconnect and store counterweight lifting pendants (see Operating Controls).
JIB BELOW HORIZONTAL [2]	Luffing jib operable. See capacity chart for luffing jib minimum operating angles.	Raise luffing jib above horizontal.
LOAD MOMENT	All load drums stop hoisting and boom and luffing jib hoist stop lowering.	Land load on load drum or raise boom or jib.
LUFFING JIB MAX DOWN [2]	Luffing jib stops lowering when boom to jib angle is 60°.	Raise luffing jib.
LUFFING JIB MAX UP [2]	Luffing jib stops raising when boom to jib angle is 168°.	Lower luffing jib.
FUNCTION IS PARKED	Function inoperable because it is parked.	Turn corresponding park switch off or sit down in operator's seat.
CYLINDER ALIGNMENT	Boom cylinders out of alignment. Stops boom movement.	Check hydraulic system for blockage or replace problem cylinder encoder.
BOOM HOIST MOTION	Unintended boom motion in either direction.	Boom hoist inoperable in either direction (cannot boom up or down). Stop and restart engine to correct fault (reboot programmable controller). Troubleshoot system to determine cause of fault (electronic displacement control or pump).

Display Reading	Function Response	Corrective Action
REMOTE ACTIVE FAULT	Control in cab inoperable.	Do not attempt to operate controls in cab when operating counterweight remote control.
DATALOGGER FAULT	Does not affect operation.	Fault will appear on screen for 60 seconds at startup if there is a datalogger problem (most likely caused by real time clock).

**Table 3-6
System Faults**

Listed below are faults which turn on system fault alert (red light and beeper). When the alert comes on, the SYSTEM FAULT group of the digital display will indicate which fault has occurred; take corrective action.

The beeper sounds intermittently (I) or continuously (C) as indicated in alert column.

Display Reading	Alert	Cause of Fault	Function Response
BOOM ANGLE SENDER	I	Sender output voltage 0 volts or above 9.7 volts. Fault not active when crane is in SETUP mode.	All functions operable, but BOOM ANGLE and BOOM TO LUFFING JIB ANGLE display will be faulty; correct cause of transducer fault as soon as possible.
ENGINE OIL PRESSURE	I	Oil pressure below 15 psi (1.0 bar).	Does not affect operation. Correct cause of low oil pressure as soon as possible to prevent engine damage.
ENGINE TEMPERATURE	I	Engine coolant temperature above 205°F (96°C).	Does not affect operation. Correct cause of overheating as soon as possible to prevent engine damage.
HYD TANK FLUID TEMP	I	Oil temperature in hydraulic tank above 180°F (82°C).	Does not affect operation. Reduce loads and/or speeds to allow oil to cool.
HYD TANK FLUID LEVEL	I	Hydraulic oil at CAUTION LOW LEVEL indicated on tank gauge.	Does not affect operation. Fill tank as soon as possible.
HYDRAULIC FILTER 1	I	Corresponding filter is dirty.	All functions operable. Replace filter as soon as possible.
HYDRAULIC FILTER 2	I		
HYDRAULIC FILTER 3	I		
HYDRAULIC FILTER 4	I		
HYDRAULIC FILTER 5	I	Strainer is dirty.	All functions operable. Clean strainer in tank on crane as soon as possible.
LUFF JIB ANGLE SEND [2]	I	Sender output voltage 0 volts or above 9.7 volts. Fault not active when crane is in SETUP mode.	All functions operable, but LUFFING JIB ANGLE and BOOM TO LUFFING JIB ANGLE display will be faulty; correct cause of transducer fault as soon as possible.
MOTOR TEMPERATURE	I	Temperature of hydraulic motor 240°F (116°C) or higher.	All functions operable. Stop operating or reduce speed and load of corresponding motor until temperature lowers to normal. To determine which motor is overheating, disconnect and connect DIN connector at switch on each motor. Fault on screen will turn off when proper DIN connector is disconnected.

[2] Optional item.

[3] Angles at which boom stops vary with attachment. See Operating Controls in the section for specifications.

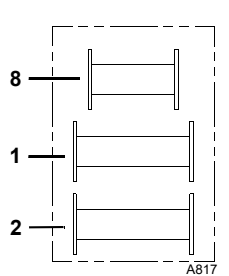

Table 3-7
Display Abbreviations

Abbreviation	Definition
+.....	Plus
-.....	Minus
%.....	Percent
A1.....	Handle Inputs
A2.....	Pump Control Outputs
A3.....	Programmer's Screen
ANG.....	Angle
AUX.....	Auxiliary
CALIB.....	Calibration
CHRG.....	Charge
CON.....	Configuration
D1.....	Digital On-Off Inputs
D2.....	Digital Inputs
D3.....	Digital Inputs or Outputs
DEG.....	Degrees (angle)
DEG F.....	Degrees Fahrenheit
FWD.....	Forward
FFall.....	Free Fall
HYD.....	Hydraulic
LUFF.....	Luffing
MIN.....	Minimum
MAX.....	Maximum
PRESS.....	Pressure
PSI.....	Pounds Per Square Inch
PSIA.....	Pounds Per Square Inch Absolute
RPM.....	Revolution Per Minute
RIN.....	Remote Input Node
SEND.....	Sender
SYS.....	System
TEMP.....	Temperature

Table 3-8
Drum Identification

Drum Number	Drum
1	Front Load Drum
2	Rear Load Drum
8	Auxiliary Load Drum (in boom butt)



DIAGNOSTIC DISPLAY

To activate the diagnostic display screens, depress the limit bypass switch and scroll up. Once this step is performed, you can scroll up and down through the diagnostic screens in addition to the normal operating screens. To deactivate the diagnostic screens, depress the limit bypass switch and scroll down. The normal operating screens will remain active.

The diagnostic display provides information about the status of all main crane components as well as the controller inputs and outputs during operation. There are a total of twelve diagnostic screens:

- Six which display information about particular crane functions — DRUMS 1, 2, and 8, BHST (Boom Hoist), SWING, and TRACK.
- Three which display information about digital inputs and outputs — D1 (outputs from crane controller), D2 (inputs to crane controller), and A1 (handle/pedal inputs to crane controller).
- Three which display controller programming information — A2, A3, and D3. These screens are for factory use only, and are not shown in this section.

See Table 3-8 for drum identification, Figure 3-30 for handle and pedal identification, and Figure 3-31 for pump identification.

Drum 1, 2, and 8

1	2	3	4	5
6	7	DRUM X		

1. Handle command in percent from neutral (+ raise, – lower)*.
2. Pump command in percent from neutral (+ raise, – lower).
3. Motor command in percent (0% max. displacement, 100% minimum displacement).
4. Parking brake command (1 release, 0 engage).
5. Clutch command (1 release, 0 engage) (applies only to drums with free fall, otherwise has no meaning).
6. Measured pump pressure (port A) in psi.
7. Measured drum speed in rpm (+ raise, – lower).

X = Corresponding drum number appears.

*For certain operating conditions the handle command can be set to neutral by the controller even if the handle is not in neutral.

BHST (Boom Hoist)

1	2	3	4
5	6	7	BHST

1. Handle command in percent from neutral (+ up, – down).
2. Pump command in percent from neutral (+ up, – down).
3. Measured pump pressure (up) in psi.
4. Measured cylinder pressure (up) in psi.
5. Port 0 count – right cylinder position (+ retract, – extend)
6. Port 1 count – left cylinder position (+ retract, – extend)
7. Boom valves:
 - 1 = raise holding valve on
 - 2 = lower holding valve on
 - 3 = both holding valves on
 - 4 = pump enable valve on
 - 5 = pump enable valve and raise holding valve on
 - 6 = pump enable valve and lower holding valve on
 - 7 = pump enable valve and both holding valves on

Swing

1	2
3	4
SWING	

1. Handle command in percent from neutral (+ right, – left)*.
2. Pump command in percent from neutral (+ right, – left).
3. Measured pump pressure swing right (port A) in psi.

4. Measured pump pressure swing left (port B) in psi.

Track

1	2	3	4
5	6	7	TRACK

1. Right handle/pedal command in percent from neutral (+ forward, – backward)*.
2. Left handle/pedal command in percent from neutral (+ forward, – backward)*.
3. Right pump command in percent from neutral (+ forward, – backward).
4. Left pump command in percent from neutral (+ forward, – backward).
5. Measured system pressure right track in psi.
6. Measured system pressure left track in psi.
7. Parking brake command (1 release, 0 engage).

*For certain operating conditions the handle command can be set to neutral by the controller even if the handle is not in neutral.

A1 (Handles)

The variable control handle output voltage is represented in the controller by a number between 0 (0 Volts) and 255 (10 Volts). Diagnostic screen A1 displays this number for each of the control handles/pedals. The normal operating outputs of the handles range from:

- approximately 38 (1.5 Volts) to 120 (4.7 Volts) for lower/reverse/right**
- approximately 136 (5.3 Volts) to 215 (8.5 Volts) for raise/forward/left**

**Some dual-axis handles (joysticks) are internally limited and will not put out the full range stated here.

A switch opens when the handle is in the neutral range (4.7 – 5.3 volts). In the neutral range, the screen reads 0 (0 volts).

1	2	3	4	5
6	7	8	9	A1

1. Handle 1 – Front Drum.
2. Handle 2 – Rear Drum.
3. Handle 3 – Boom Hoist.
4. Handle 5 – Right Track.
5. Handle 6 – Left Track.
6. Handle 4 – Swing.
7. Handle 7 – Auxiliary Drum.

- 8. Pedal 1 – Right Track.
- 9. Pedal 2 – Left Track.

D1 and D2 (Digital Outputs and Inputs)

The status of the digital outputs from the controller and the inputs to the controller is displayed in several banks in screens D1 and D2. Each bank can indicate the state of up to eight individual digital inputs or outputs.

1	_2_	_3_	_4_	_5_
6	_7_	_8_	D X	

Items 1 through 8 are bank numbers.

X = Corresponding digital screen number (1 or 2) appears.

Each individual input/output is assigned a number (identifier) in the binary system (powers of two). The identifiers of all inputs/outputs that are ON (active), are added to a total in each bank. Thus, the number displayed for each bank is the sum of all identifiers of the inputs/outputs that are ON (0 – 255). With this system, each possible ON/OFF combination per bank has a unique total.

For identification of the digital outputs and inputs (and the crane components connected to them) see Tables 3-9 and 3-10 in this section.

To determine the state of the individual inputs/outputs in a bank, find the number displayed for the bank in the first column in Table 3-11. In the corresponding row the identifier

numbers that are ON (active) in the bank are shaded. Use Tables 3-9 and 3-10 to identify the crane components associated with the identifiers for the corresponding bank.

Example 1: The number displayed in Bank 5 of screen D2 of the digital display is 41. Go to row number 41 in Table 3. The boxes for identifiers 1, 8 and 32 are shaded in this row, indicating that the corresponding inputs are active. Find the component description for the identifiers in Table 2, Bank 5. In this example, the inputs for Front Pawl In (1), Auxiliary Drum Pawl In (8), and Seat Switch (32) are active.

Example 2: You want to know if the controller output for the rear drum band brake is ON. In Table 1 you will find Rear Drum Band Brake in Bank 1 (identifier 2). Look up the current number for Bank 1 in screen D1 on the digital display (e.g. 152). Then go to the corresponding row number (152) in Table 3. Identifier 2 box is not shaded in this row, indicating that the controller output to the rear drum band brake is OFF.

NOTE: All numbers in screen D1, and the pump/motor command values in screens DRUM, SWING and TRACK represent controller commands to the corresponding output devices only. The state of a certain output port on the controller may not necessarily correspond to the actual state of the associated crane component (brake valve, clutch valve, etc.), since the connection between the controller and the component may be faulty due to loose connections, corroded terminals, broken wiring or improperly operating components.

Table 3-9
D1 (Digital Outputs)

Identifier*	Component
Bank 1	
1	Front Drum Band Brake
2	Rear Drum Band Brake
4	Boom Up Enable
8	Travel Park Brake
16	Boom Down Enable
32	Right Front Drum Clutch Free Fall
64	Right Rear Drum Clutch Free Fall
128	Front Drum Disc Brake
Bank 2	
1	Rear Drum Disc Brake
2	Spare
Bank 3	
1	Auxiliary Drum Disc Brake
2	Spare
4	Swing & Travel Alarm
8	Operating Limit Alarm
16	System Fault Alarm
32	Boom Pump Enable Valve
64	Left Front Drum Clutch Free Fall
128	Left Rear Drum Clutch Free Fall
Bank 4	
1	Front Drum Free Fall Light
2	Rear Drum Free Fall Light
Bank 5	
1	Spare
2	Front Drum Rotation Indicator
4	Rear Drum Rotation Indicator
8	Boom Cylinder Up/Down Indicator
16	Auxiliary Drum Rotation Indicator
32	2-Speed Travel Valve
64	Spare Digital Output-27
128	Spare Digital Output-28
Bank 6	
1	Spare Digital Output-29
2	Spare Digital Output-30
Bank 7	
1	Spare Digital Output-31
2	Spare Digital Output-32
4	Spare Digital Output-33
8	Spare Digital Output-34
16	Spare Digital Output-35
32	Auxiliary Drum Pump Control – Up
64	Auxiliary Drum Pump Control – Down

Table 3-10
D2 (Digital Inputs)

Identifier*	Component
Bank 1	
1	Travel Detent Set/Cancel
2	Maximum Bail Limit – Front Drum
4	Minimum Bail Limit – Front Drum
8	Left Side Counterweight Limit Switch
16	Right Side Counterweight Limit Switch
32	Boom Point Block-Up Limit
64	Maximum Bail Limit – Rear Drum
128	Minimum Bail Limit – Rear Drum
Bank 2	
1	Select Mode
2	Confirm Mode
4	Max Boom/Luffing Angle Limit Bypass
8	Boom Maximum Up Limit
16	Boom Maximum Down Limit
32	Luffing Jib Maximum Up Limit
Bank 3	
1	Luffing Jib Maximum Down Limit
2	Minimum Hydraulic Fluid Level
4	Maximum Hydraulic Fluid Temperature
8	Engine Oil Pressure
16	Engine Coolant Temperature
32	Left Front Drum Clutch Switch
64	Rear Drum Free Fall Safety Switch
128	Right Front Drum Clutch Switch
Bank 4	
1	Front Drum Free Fall Safety Switch
2	Rated Capacity Indicator/Limiter
4	Limit Bypass
8	Display Scroll Up
16	Setup Remote – Boom Up
32	Setup Remote – Boom Down
Bank 5	
1	Front Drum Pawl In
2	Rear Drum Pawl In
4	Left Rear Drum Clutch Switch
8	Auxiliary Drum Pawl In
16	Display Scroll Down
32	Seat Switch
64	High-Speed Travel
128	Right Rear Drum Clutch Switch
Bank 6	
1	Front Drum Disc Brake
2	Rear Drum Disc Brake
4	Boom Cylinder Enable
8	Travel Park Brake
16	Auxiliary Drum Disc Brake
32	Auxiliary Drum Minimum Bail Limit
Bank 7	
1	Spare
2	Swing Park Brake
4	Hydraulic Filter Alarm 1
8	Hydraulic Filter Alarm 2
16	Hydraulic Filter Alarm 3
32	Hydraulic Filter Alarm 4
64	Hydraulic Filter Alarm 5
128	Boom Cylinders Hold
Bank 8	
1	Spare
2	Boom Right Cylinder Encoder Channel A7
4	Boom Right Cylinder Encoder Channel B7
8	Boom Left Cylinder Encoder Channel A8
16	Boom Left Cylinder Encoder Channel B8
32	Hydraulic Filter Alarm 6

* Binary

** These digital ports are pulsed for auxiliary pump control. For both ports a digital ON is displayed when pulsing, to prevent a flickering number for the corresponding bank.



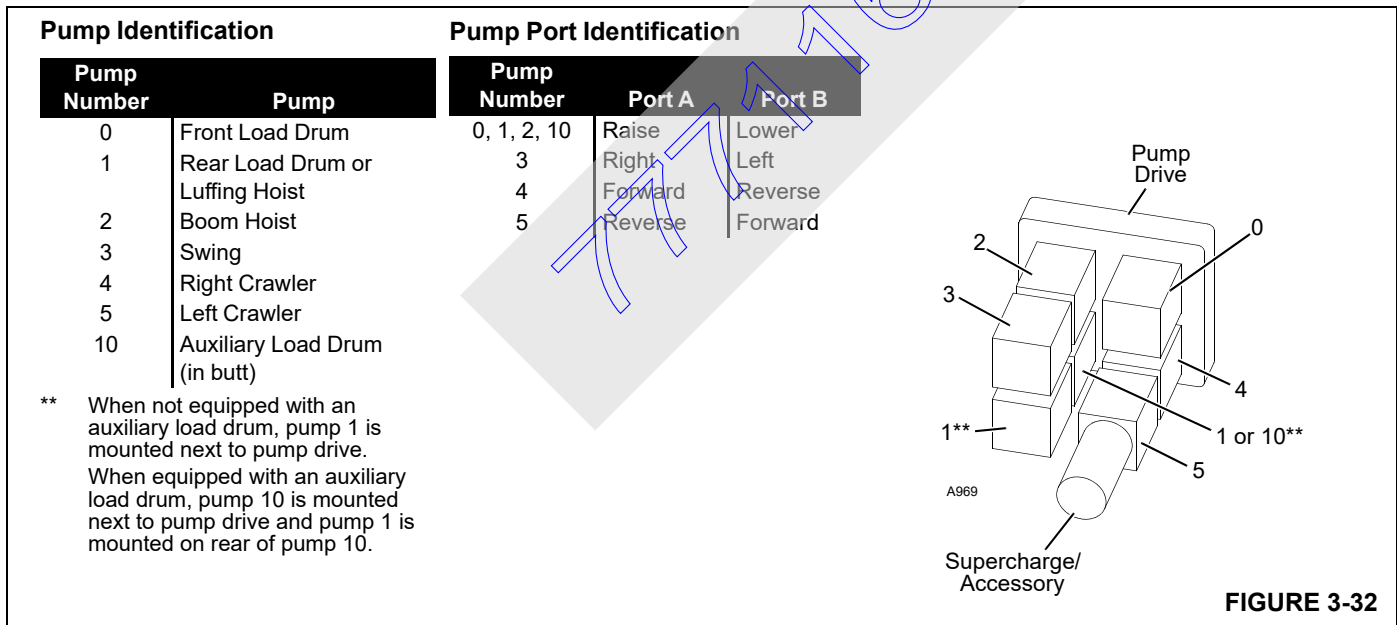
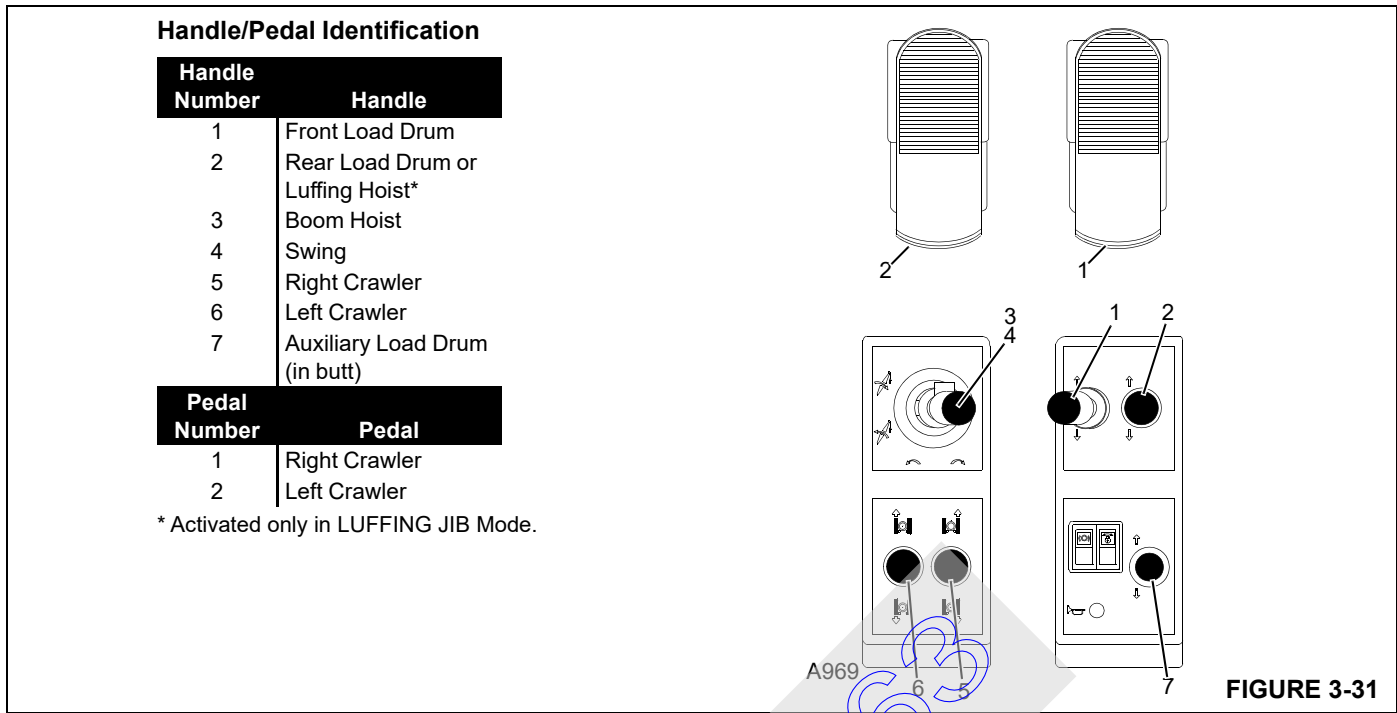

Table 3-11
8-Bit Binary System

	1	2	4	8	16	32	64	128
1								
2								
3								
4								
5								
6								
7								
8								
9								
10								
11								
12								
13								
14								
15								
16								
17								
18								
19								
20								
21								
22								
23								
24								
25								
26								
27								
28								
29								
30								
31								
32								
33								
34								
35								
36								
37								
38								
39								
40								
41								
42								
43								
44								
45								
46								
47								
48								
49								
50								
51								
52								
53								
54								
55								
56								
57								
58								
59								
60								
61								
62								
63								
64								
65								
66								
67								
68								
69								
70								
71								
72								
73								
74								
75								
76								
77								
78								
79								
80								
81								
82								
83								
84								
85								
86								
87								
88								
89								
90								
91								
92								
93								
94								
95								
96								
97								
98								
99								
100								
101								
102								
103								
104								
105								
106								
107								
108								
109								
110								
111								
112								
113								
114								
115								
116								
117								
118								
119								
120								
121								
122								
123								
124								
125								
126								
127								
128								
129								

Dark shaded boxes indicate ON; white boxes OFF.

Table 3-11
8-Bit Binary System (continued)

	1	2	4	8	16	32	64	128
130								
131								
132								
133								
134								
135								
136								
137								
138								
139								
140								
141								
142								
143								
144								
145								
146								
147								
148								
149								
150								
151								
152								
153								
154								
155								
156								
157								
158								
159								
160								
161								
162								
163								
164								
165								
166								
167								
168								
169								
170								
171								
172								

	1	2	4	8	16	32	64	128
173								
174								
175								
176								
177								
178								
179								
180								
181								
182								
183								
184								
185								
186								
187								
188								
189								
190								
191								
192								
193								
194								
195								
196								
197								
198								
199								
200								
201								
202								
203								
204								
205								
206								
207								
208								
209								
210								
211								
212								
213								
214								
215								

	1	2	4	8	16	32	64	128
216								
217								
218								
219								
220								
221								
222								
223								
224								
225								
226								
227								
228								
229								
230								
231								
232								
233								
234								
235								
236								
237								
238								
239								
240								
241								
242								
243								
244								
245								
246								
247								
248								
249								
250								
251								
252								
253								
254								
255								

Dark shaded boxes indicate ON; white boxes OFF.

SWING LIMITER OPERATION

Swing limiter system is a safety device that allows operator to program how far rotating bed can be swung right and left. When programmed limit is reached in either direction, programmable controller automatically stops rotating bed and prevents swing past programmed limit. The operator can swing in the opposite direction.

The system consists of the following components (see Figure 3-33):

- Swing Sensor — Electronically monitors swing speed and direction and sends corresponding electric signals to crane’s programmable controller.
- Crane Mode Keyswitch — Used to turn swing limits on and off.
- Digital Display — Contains swing limiter programming screens.
- Programmable Controller — Receives input signals from swing sensor and crane mode keyswitch, and controls swing pump to stop rotating bed and hold it in position at programmed swing limits.
- Limit Switch and Actuators — Apply swing parking brake to stop rotating bed if programmed swing limits fail for any reason.

! WARNING
Operator Aid!

Swing limiter is a safety device designed to stop rotating bed (prevent crane or boom from swinging into job site obstructions) in event operator fails to stop rotating bed from swinging in normal manner. Any other use of swing limiter is neither intended nor approved.

Programming Swing Limits

Check programmed swing limits daily at start of operation by swinging slowly to each limit. The rotating bed should stop smoothly when either swing limit is reached.

1. Access diagnostic screens on digital display by depressing scroll up and bypass switches at same time.
2. Scroll through diagnostic screens until either of following screens appears.



3. To **TURN OFF** swing limits:
 - a. Turn crane mode keyswitch to SELECT position. An asterisk * will appear to left of SWING LIMITER line.
 - b. Scroll up or down to LIMITS OFF.
 - c. Turn crane mode keyswitch to SELECT position. Swing limits will be turned off and asterisk will disappear.
 - d. Remove limit switch actuators.

CAUTION

Avoid Shock Load Damage to Boom and Jib!

Remove limit switch actuators prior to operating crane with swing limiter system turned off.

Limit switch will apply swing parking brake when either actuator is contacted if this step is not performed. Crane rotating bed will stop abruptly, possibly resulting in shock load damage to boom and jib.

4. To **SET LIMITS**:
 - a. Remove limit switch actuators if they will interfere with desired programmed limits.
 - b. Make sure crane’s swing motion is stopped at any position between desired swing limits.
 - c. Turn crane mode keyswitch to SELECT position. An asterisk * will appear to left of SWING LIMITER line.
 - d. Scroll up or down to SET LIMITS.



NOTE: The programmed swing limits have an accuracy of ±1.5 degrees of rotation (approximately ±0.5 ring gear tooth).

- e. Swing rotating bed to desired right or left position and bring rotating bed to smooth stop. *Do not swing beyond desired limit.*
- f. Swing rotating bed in opposite direction and bring rotating bed to a smooth stop at desired position. *Do not swing beyond desired limit.*
- g. Scroll up to LIMITS ON to activate selected limits.
- h. Turn crane mode keyswitch to SELECT position. Swing limits will remain on and asterisk will disappear.
- i. Install and adjust limit switch actuators.



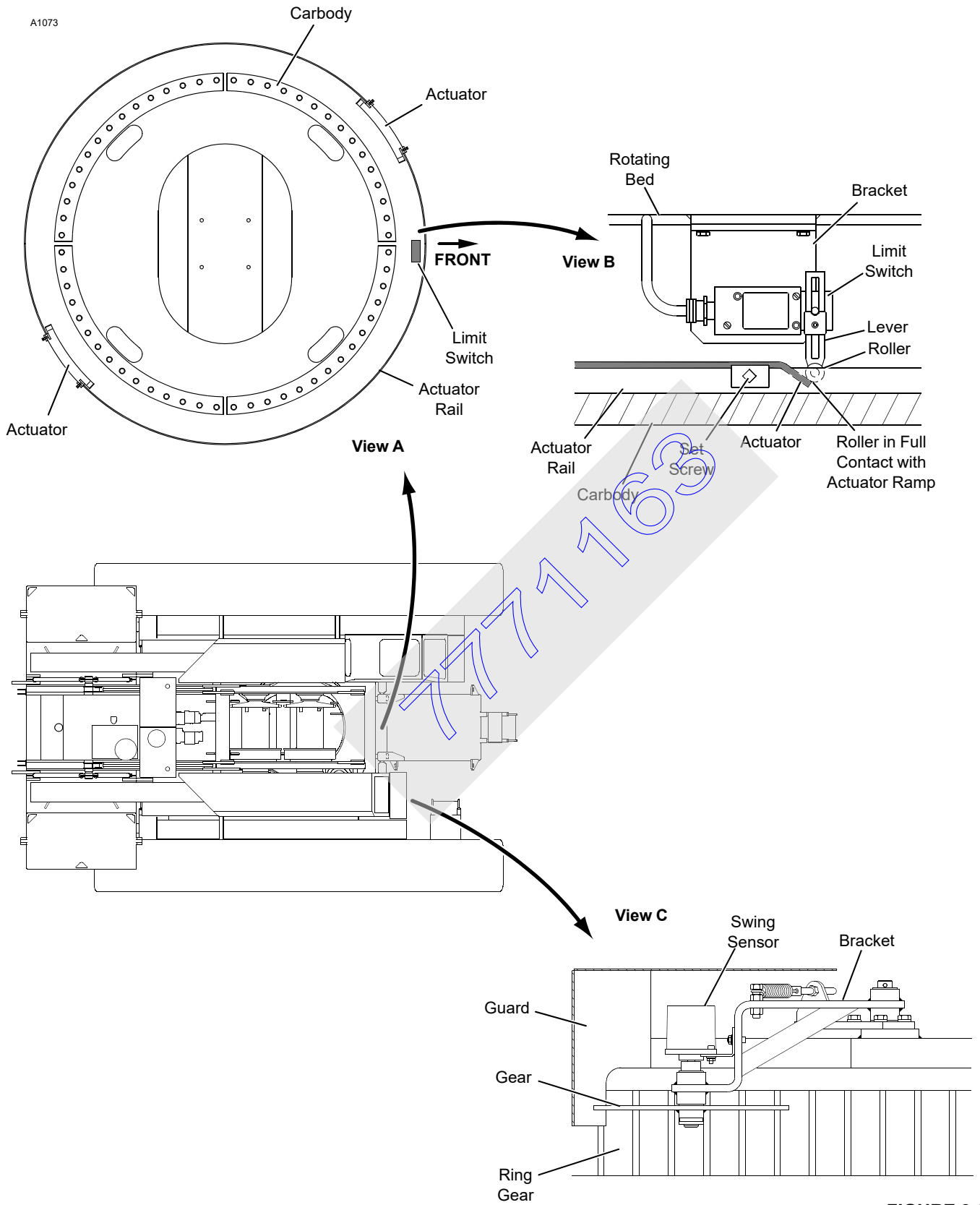

FIGURE 3-33

THIS PAGE INTENTIONALLY LEFT BLANK

777163

Adjusting Swing Limit Switch

The physical limits defined by position of limit switch actuators cannot be bypassed. If either actuator is contacted, swing pump shifts to neutral and swing brake applies.

Limit switch is mounted on front outboard side of rotating bed for easy access.

1. At initial set-up only, adjust limit switch lever so roller is in full contact with actuator ramp (Figure 3-33).
2. Remove both limit switch actuators from actuator rail.
3. Program swing limits.
4. Swing rotating bed in either direction to programmed right or left swing limit.
5. Engage swing lock.
6. Place actuator on rail (Figure 3-33 View B) — to right of limit switch for swing right limit or to left of limit switch for swing left limit — so actuator just lightly contacts limit switch roller. *Do not trip limit switch open while performing this step.*
7. Securely tighten setscrews to secure actuator.
8. Swing rotating bed to programmed swing limit in opposite direction and repeat steps 6 – 7.

NOTE: The operator can swing away from either actuator by moving swing handle in opposite direction and building a pressure in that direction (if pump control is stuck in wrong direction, pressure will not build up in safe direction and brake will never release).

If for any reason machine swings in wrong direction after brake has been released (i.e., crane out of level or excessive side wind) the brake will reapply. The operator is free to attempt to swing away from the actuator again or stop and investigate. After several attempts, it is possible to "ratchet" oneself well beyond the limit.

Operator, if you are unable to swing away from actuators in 2-3 attempts, stop and move crane away from dangerous area before trying to swing again.

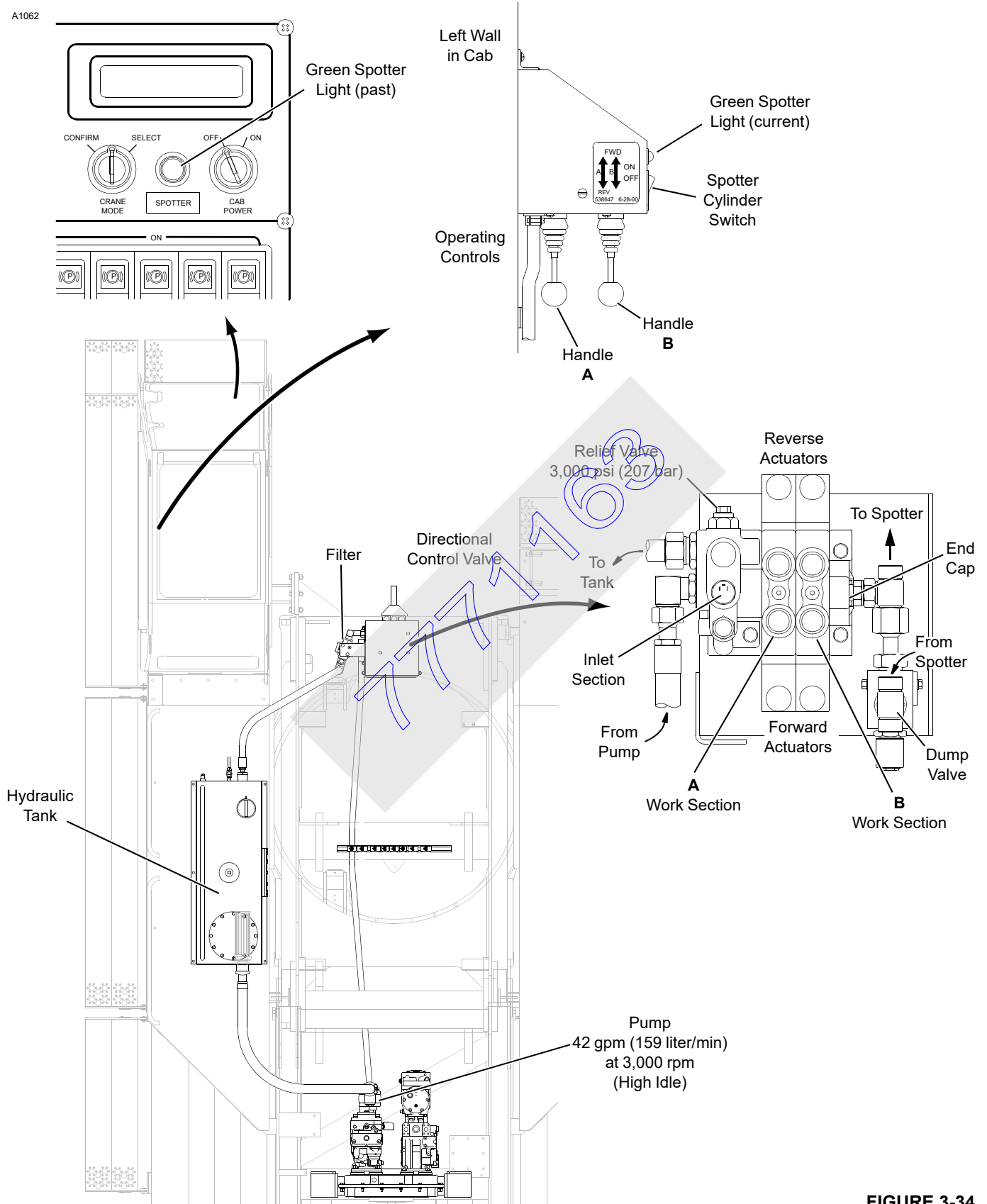

FIGURE 3-34

HYDRAULIC SYSTEM CONTROLS

This topic identifies location and function of hydraulic components Manitowoc has provided for the Customer Supplied Pile Driving System.

See Figure 3-34 for location of hydraulic components.

Components Function

Hydraulic Tank

The hydraulic tank is mounted on left side machinery enclosure. It houses the hydraulic oil for the system.

A sight gauge and level decal are provided on outside of tank.

Tank contains a 100-mesh suction screen which prevents large pieces of foreign matter from entering pump.

Hydraulic Pump

The pump is mounted on and driven by the 777 front drum pump.

The pump is a gear type with a flow rating of 42 gpm (159 liters/min) at 3,000 rpm, when engine is operated at high idle.

Directional Control Valve

The directional control valve is mounted on front of rotating bed. The valve has four sections:

- Inlet section which routes oil from pump to two work sections (A and B) of valve and routes return oil flow from work sections through filter back to tank.

The inlet section has a relief valve which limits system pressure to 3,000 psi (207 bar).

- Two electrically controlled work sections that are spring returned to neutral. The work sections direct oil flow to customer supplied cylinders in response to controls in operator's cab.
 - Work sections A and B have a 4-way, 3-position spool for controlling a cylinder. When in neutral, work section valves A and B lock cylinders in

position and allow oil flow to customer supplied spotter system control valve. When enabled, work station valves A or B direct oil flow to customer supplied cylinders. Return oil from cylinders flows to inlet section then through system filter and back to tank.

- The end cap routes return oil back to inlet section or to spotter system.

Hydraulic Filter

The hydraulic filter is mounted along side directional control valve in return line to tank.

The filter has a 10-micron, spin-on type element with a visual service indicator.

Spotter System Dump Valve

Spotter switch is a 2-position maintained rocker, located on operator's cab upper left wall. The Spotter switch controls operation of 2-position dump valve. The lock on rocker must be moved up before rocker can be placed in ON position. When Spotter switch is ON, green SPOTTER light on front console comes on. The dump valve closes to allow oil flow from directional control valve to spotter system control valve. When rocker is placed in OFF position, green SPOTTER light goes out. The dump valve opens to allow oil flow through the system filter and back to tank.

NOTE: When one or both directional control valves are operating, oil available to operate spotter system is greatly reduced.

Cylinder Operating Controls

The controls are 3-position, handle-operated electric valves which provided variable control of the customer supplied cylinders.

Handle A controls forward and reverse operation of the A work section of directional control valve. Handle B controls forward and reverse operation of the B work section of directional control valve. Exact operation of controls depends upon how the customer connects the hydraulic lines to cylinders.

Forward stability is affected by wind on the rear of the boom. Wind applies a force to the boom and load that adds to the crane's overturning moment. This action has the same effect as adding load to the hook.

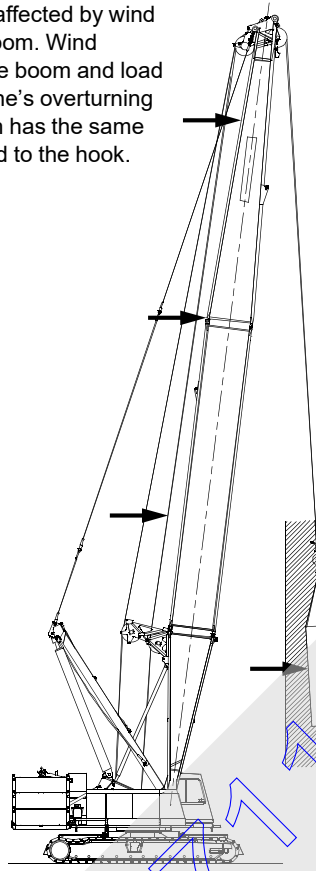

The wind's affect on the rear of the load increases load radius. This condition can result in an overload hazard, possibly causing the crane to tip or the boom to collapse.

To avoid this hazard, reduce operating speeds and load (see appropriate table for recommended capacity reductions).

A1019

Backward stability is affected by wind on the front of the boom. This condition is especially dangerous when the boom is at or near the maximum angle when operating without load.

Wind forces on the front of the boom reduce the normal forward tipping effect of the boom. The crane can tip or the boom can collapse if this condition is not avoided.

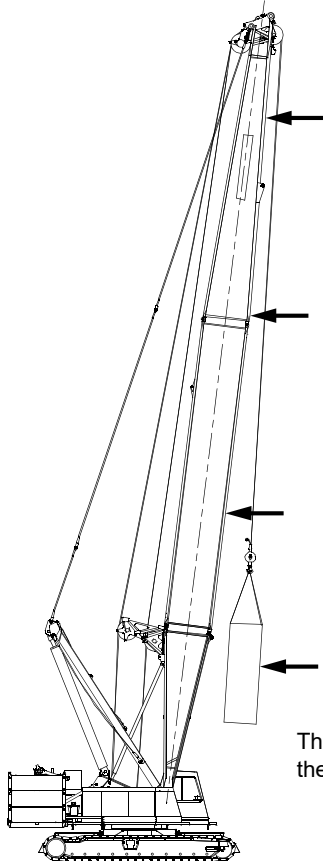

The boom can buckle and collapse if the load contacts the boom.

Boom strength is affected the most when the wind acts on the side of the boom.

The wind's affect on the side of the load can cause the load to swing out past the boom hinge pin. This condition can result in excessive side load forces on the boom, possibly causing the crane to tip or the boom to collapse.

To avoid this hazard, reduce operating speeds and load (see appropriate table for recommended capacity reductions).

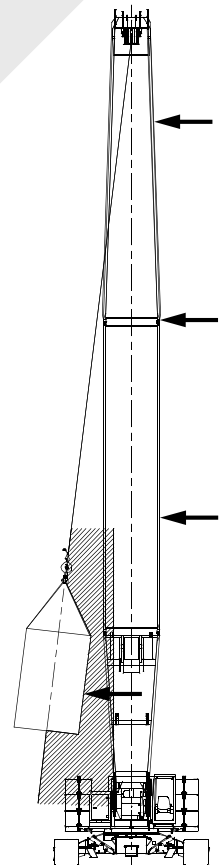

FIGURE 3-35

WIND CONDITIONS

Wind adversely affects lifting capacity and stability as shown in Figure 3-35. The result could be loss of control over the load and crane, even if the load is within the crane's capacity.



WARNING **TIPPING CRANE HAZARD!**

Judgment and experience of qualified operators, job planners, and supervisors must be used to compensate for affect of wind on lifted load and boom by reducing ratings, reducing operating speeds, or a combination of both.

Failing to observe this precaution can cause crane to tip or boom and/or jib to collapse. Death or serious injury to personnel can result.

For wind conditions specific to this crane, see Wind Conditions Chart at end of this section or, if applicable, see wind conditions in Capacity Charts provided with crane and attachments.

Wind speed (to include wind gusts) must be monitored by job planners and supervisors.

Beware that wind speed at boom or jib point can be greater than wind speed at ground level. Also beware that the larger the sail area of the load, the greater the wind's affect on the load.

As a general rule, ratings and operating speeds must be reduced when:

Wind causes load to swing forward past allowable operating radius or sideways past either boom hinge pin.

777163

COLD WEATHER HEATER PACKAGE

General

The heaters provided in the cold weather heater package preheat critical machinery and lubricant sumps during cold weather shutdown. Figure 3-36 identifies heater components.

A 777 working in an arctic climate — **outside temperature continuously below 0°F (-18°C) to -30°F (-34°C)** — should be equipped with the heaters identified in this topic and lubricated with the lubricants listed in Section 5 of this manual.

CAUTION

Machinery Damage!

Operating in an arctic climate without heaters can damage machinery during cold weather start-up due to lack of lubrication.

Heater package described in this topic may not provide adequate protection when operating below -30°F (-34°C). Contact Service Department at factory for recommendations.

CAUTION

Hydraulic Pump Damage!

To prevent damage to pumps, warm hydraulic oil to 60°F (16°C) minimum before operating crane in an arctic climate.

Heaters

The heaters operate on electrical power supplied by an owner furnished external power supply.

120 Volt AC Option

The heater package includes the following:

- Engine Oil Sump (300 watts)
- Hydraulic Oil Tank (two, 500 watts each)
- Control Console (30 watts)

NOTE: A 1,500 watt engine coolant heater is supplied as standard equipment with the engine. This heater has its own cord. The total power requirement for the heater package plus the coolant heater is 2,830 watts.

240 Volt AC Option

The heater package includes the following:

- Engine Oil Sump (300 watts)
- Engine Coolant (1,000 watts)
- Hydraulic Oil Tank (two, 500 watts each)
- Control Console (125 watts)

Thermostats

Thermostats turn the heaters on and off at the temperatures listed below.

Heater	Heater On	Heater Off
Hydraulic Oil Reservoir	60°F (16°C)	80°F (27°C)
Engine Oil Sump	60°F (16°C)	80°F (27°C)
Control Console	50°F (10°C)	60°F (16°C)

Turning Heaters On

1. Check that external power supply is off.



WARNING

Electrocution Hazard!

Severe electric shock can cause death or serious injury. Crane owner/user must make provisions for turning off electrical power supply before connecting and disconnecting power supply cords

2. Connect external power supply cord to cord at hydraulic tank on crane.
3. Turn on external power supply.

Turning Heaters Off

1. Turn off external power supply.
2. Unplug external power supply cord from cord at hydraulic tank on crane.

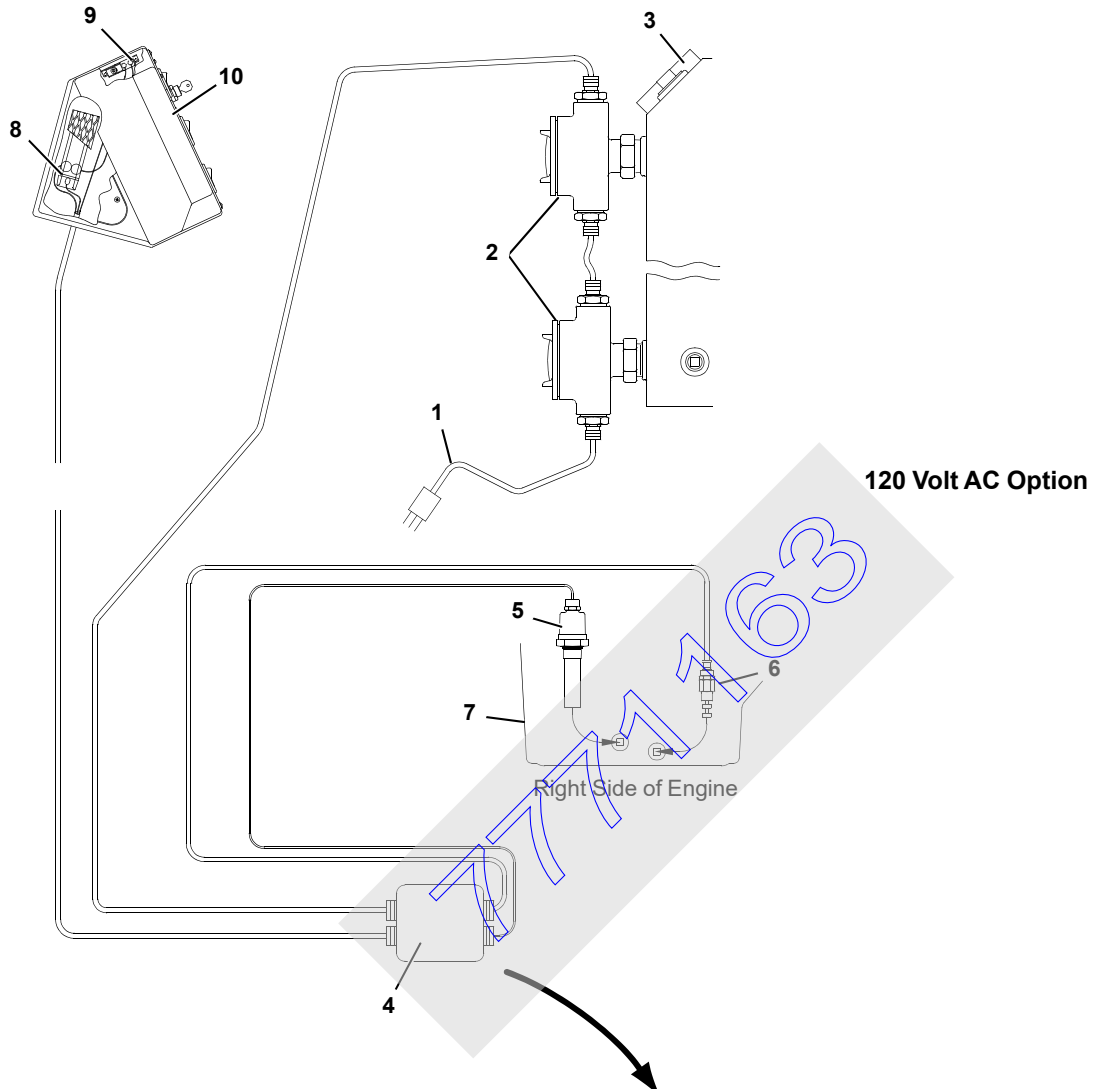

A1089

Item	Description
1	Power Supply Cord
2	Hydraulic Reservoir Heaters (two, 1000 watts total)
3	Hydraulic Reservoir
4	Junction Box (front of rotating bed beam under engine)
5	Oil Pan Thermostat (C-330 engine only)
6	Oil Pan Heater (300 watts)
7	Oil Pan
8	Control Console Heater (30 watts)
9	Control Console Thermostat
10	Front Control Console
11	Beam (engine base)

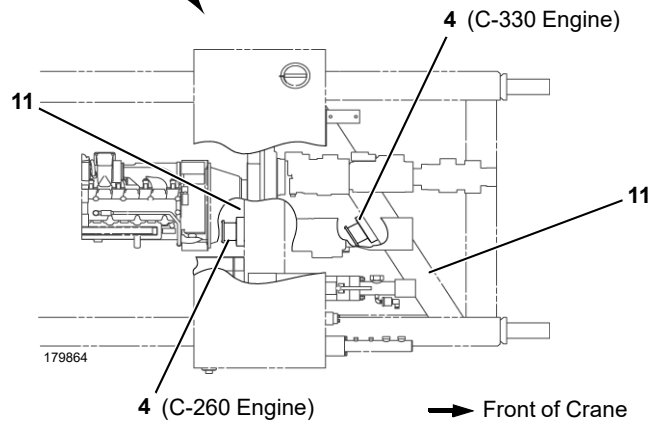
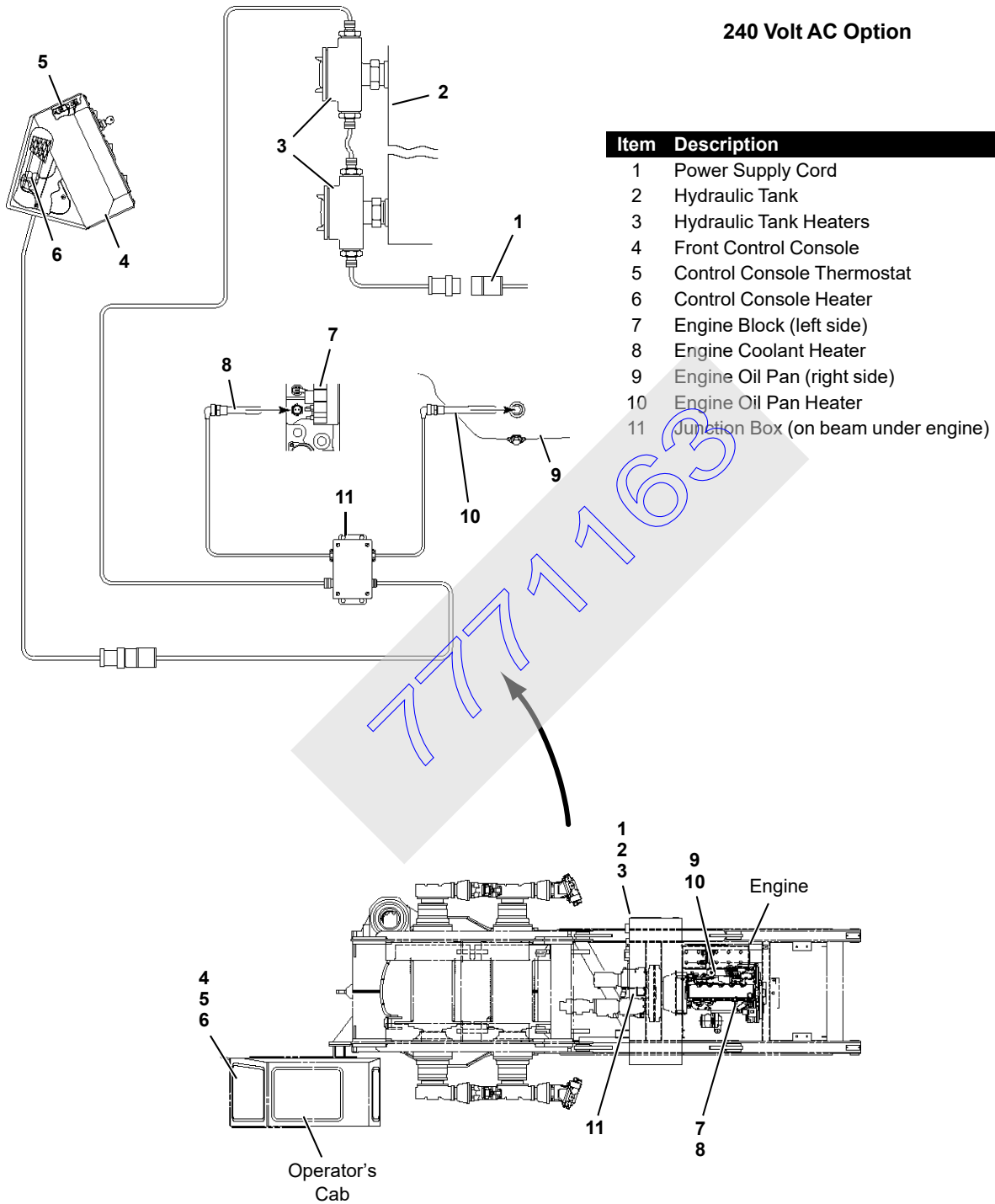

FIGURE 3-36

P2092

240 Volt AC Option



3

FIGURE3-36continued

PREPARATION FOR COLD WEATHER

Crane Limitations

The static load carrying limitations of the steels used in Manitowoc cranes is not affected by cold weather. Manitowoc's capacity charts are acceptable for use in cold weather.

Dynamic loads (impact and shock) can affect the steels used in Manitowoc cranes when operating in cold weather. Dynamic loads are created by traveling, sudden application and release of load, and duty-cycle operations.

To prevent possible damage to the crane and its attachment when operating during cold weather Manitowoc recommends:

- At -5 to -22°F (-21 to -30°C) — Avoid impact or shock loading of crane and attachment. Operations involving hydraulic cranes should be conducted with regard to potential failure of hydraulic components.
- At -23 to -40°F (-31 to -40°C) — De-rate crane by 40% for all lift operations. Halting all lifts should be considered. Duty-cycle operation is prohibited.
- Below -40°F (-40°C) — All operation (lift and duty-cycle) is prohibited except in extreme emergencies, and then only with approval from a competent engineer who has de-rated the crane accordingly.

Wire Rope

Wire rope manufacturers indicate that wire rope will not become brittle in temperatures down to -30°F (-34°C). Lubrication may be a problem during extreme cold weather as normal wire rope lubricants may harden and chip off leaving the rope without lubrication.

Consult your wire rope supplier for recommended cold-weather lubricants.

Cold Weather Starting Aid

Engine startup at temperatures below 40°F (4°C) requires the use of a cold weather starting aid.



DANGER

Engine Explosion Hazard!

The crane engine has an air intake pre-heater, do not spray any combustible starting aid (ether) into air intake.

Pre-heater will ignite ether causing a severe explosion and/or burns.

Coolant and Oil Pan Heaters

A 120 volt coolant and oil pan heater can be installed in the engine. The heaters use an electric heating element to heat the coolant and oil inside the engine when the crane is idle. Each heater has an extension cord for connecting to an owner furnished electric power supply. The coolant heater must be capable of maintaining the engine's coolant and oil temperatures between 40 to 50°F (4 to 10°C). Contact the nearest engine distributor for availability and installation of the heaters.

Engine heaters must be unplugged when engine is running to prevent cooling system from overheating.

Cooling System

The cooling system must be kept full and be protected from freezing at the lowest expected ambient temperature. See the engine manual for antifreeze recommendations.

A mixture of 40% antifreeze and 60% water provides freeze protection to -35°F (-37°C). A mixture of 60% antifreeze and 40% water provides freeze protection to approximately -60°F (-51°C). 100% antifreeze will freeze at -10°F (-23°C).

Battery

To provide maximum cranking power and to prevent the battery from freezing, it must be kept fully charged (1.26 to 1.28 specific gravity) and warm when the crane is idle during cold weather.

It is recommended that the battery be stored indoors or heated with a battery heater when the crane is idle.

Be aware that:

- A battery with a 50% charge freezes at -16°F (-27°C). A battery with a 100% charge freezes at -70°F (-57°C).
- A battery with a 100% charge retains only 40% of its cranking power at 0°F (-18°C). At -20°F (-29°C), the same battery retains only 18% of its cranking power.

Engine Oil

See engine manufacturer's manual for recommendations.

Fuel Oil

See engine manufacturer's manual for recommendations.

Gear Oil

Hydraulic Cranes

Use a gear oil which meets MIL-L-2105C specification or API-GL-5 classification. Change to one of the following viscosities when the corresponding temperature range will be encountered:

- 75W-90 below: -10°F (-23°C).

- 80W-90 above: -10 to 100°F (-23 to 38°C)
- 85W-140 above: 100°F (38°C)

Hydraulic Oil

General

Optional thermostatically controlled heaters (120 or 240 volt) can be installed in the hydraulic tank to aid in cold-weather startup.

The heaters are designed to keep the oil temperature 30°F (17°C) warmer than ambient air temperature. Each heater

has an extension cord for connecting to an owner furnished electric power supply.

Hydraulic tank heaters must be unplugged when engine is running to prevent hydraulic system from overheating.

Change the oil in the hydraulic system to ISO Grade 15 when the expected ambient temperature will remain at 32°F (0°C) or below.

Change the oil in the hydraulic system to ISO Grade 46 when the expected ambient temperature will remain above 32°F (0°C).

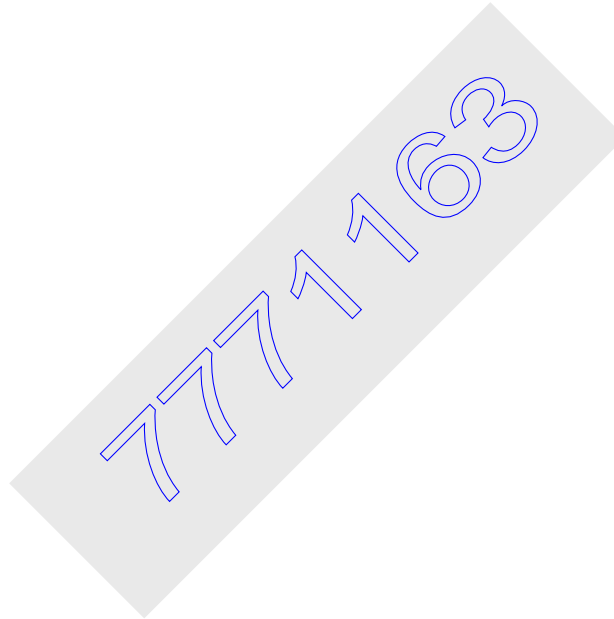

THIS PAGE INTENTIONALLY LEFT BLANK

777163

SECTION 4

SET-UP AND INSTALLATION

TABLE OF CONTENTS

Rigging Drawings	4-1
Optional Attachments	4-1
General Safety	4-1
Crane Orientation	4-1
Self-Erecting Equipment	4-1
Assembly and Disassembly Notes	4-2
Assembly and Disassembly Area	4-2
Accessing Parts	4-2
Crane Weights	4-2
Retaining Connecting Pins	4-2
Cold Weather Mast Operation	4-2
Lowerworks Lubrication at Assembly	4-2
Operating Limitations	4-4
Operating Controls	4-5
Shipping Crane Components	4-5
Crane Assembly	4-7
Pre-Start Checks	4-7
Engine	4-7
Gear Boxes	4-7
Hydraulic System	4-7
Remove Crane from Trailer	4-7
Install Crawlers	4-11
Install Counterweights	4-12
Assemble Boom	4-17
Connect Boom Butt To Boom	4-17
Pre-raising Checks	4-20
Crane Disassembly	4-23
Disconnect Butt From Boom	4-23
Install Assembly Block	4-25
Disassemble Boom	4-27
Remove Counterweights	4-27
Remove Crawlers	4-31
Install Crane on Trailer	4-33
Auxiliary Load Drum Installation	4-33
Crane Requirements	4-33
Modifications	4-33
Equipment Required	4-33
Drum Installation	4-33
Hydraulic and Electric Connections	4-35
Wire Rope Installation	4-35
Butt Removal	4-35
Boom Ladder Assembly	4-37
Removal From Boom Butt	4-37
Installation on Boom Inserts	4-37
Storage in Boom Butt	4-37
Boom Rigging Guide	4-38
Assist Crane Requirements	4-38
Blocked Crawlers	4-41
Handling Components	4-41
Boom Rigging Assembly Drawing	4-41
Identifying Boom Sections And Pendants	4-41

Removable Lacings	4-43
Storing Jib Sections	4-43
Removing Jib Sections	4-43
Boom Installation	4-45
Assemble Boom	4-45
Install Intermediate Suspension	4-47
Install Pendants	4-47
Install Upper Boom Point	4-47
Install Jib	4-48
Connect Boom Butt to Boom	4-48
Install Load Line	4-48
Install Block-Up Limit Control	4-48
Install Rated Capacity Indicator/Limiter Components	4-48
Install Wind Speed Indicators	4-48
Perform Pre-raising Checks	4-48
Boom Removal	4-48
Store Load Lines	4-48
Remove Electrical Components from Boom and Jib	4-48
Disconnect Boom Butt from Boom	4-48
Install Assembly Block	4-48
Remove Jib	4-48
Remove Upper Boom Point	4-48
Disconnect Pendants	4-48
Remove Intermediate Suspension	4-49
Disassemble Boom	4-49
Pile Driver Adapter	4-52
Operating Specifications	4-52
With Standard Top	4-52
Jib Rigging Guide	4-53
Assist Crane Requirements	4-53
Blocked Crawler/Extended Outriggers	4-55
Jib Assembly Drawing	4-55
Identifying Jib Sections and Pendants	4-55
Past Production:	4-55
Current Production:	4-55
Installing Jib	4-57
Prepare Boom	4-57
Install Jib Butt	4-57
Install Jib Inserts	4-57
Install Jib Top	4-57
Install Jib Pendants	4-59
Install Backstay Pendants	4-59
Install Jib Offset Links or Pendants	4-59
Raise Jib Strut	4-61
Install Jib Stop	4-61
Finish Rigging Boom	4-61
Removing Jib	4-61
Lower Boom and Jib	4-61
Store Jib Stop	4-62
Lower Strut	4-62
Remove Backstay Pendants	4-62
Remove Jib Pendants	4-62
Remove Jib Top and Inserts	4-62
Remove Jib Butt	4-62
Wire Rope Installation	4-63
Wire Rope Storage	4-63
Removing Wire Rope from Shipping Reel	4-63

Seizing and Cutting Wire Rope	4-64
Anchoring Wire Rope to Drum	4-64
Winding Wire Rope onto Drum	4-65
Anchoring Wire Rope to Wedge Socket	4-66
Breaking in Wire Rope	4-68
Pad Eye Usage for Wire Rope Reeving	4-68
General	4-68
Safety	4-68
Load Line Reeving	4-70
Reeving Diagrams	4-70
Wire Rope Specifications	4-70
Wire Rope Installation	4-70
Guide Sheave Identification	4-70
Load Pin Sheaves	4-70
Universal Anchor Joint	4-70
Load Blocks	4-70
Clamshell Reeving	4-76
General	4-76
Wire Rope Specifications	4-76
Wire Rope Installation	4-76
Load Block Tieback	4-79
Specifications	4-79
Shackle	4-79
Sling Length	4-79
Sling Capacity	4-79
Universal Anchor Joint	4-80

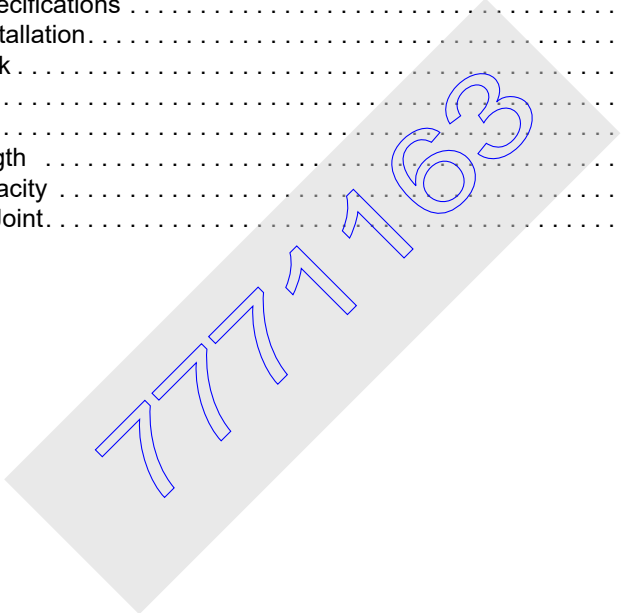

THIS PAGE INTENTIONALLY LEFT BLANK

777163

SECTION 4

SET-UP AND INSTALLATION

RIGGING DRAWINGS

For boom and jib rigging drawings that apply to your crane, see end of this section.

OPTIONAL ATTACHMENTS

If applicable, instructions for optional attachments that apply to your crane, are located at the end of this section.

GENERAL SAFETY

To prevent accidents that can result in death or injury during crane assembly and disassembly, comply with following general safety information and with specific safety information contained in assembly and disassembly steps.



WARNING

Avoid Death or Serious injury!

Read and understand setup and installation instructions in this section before attempting to assemble or disassemble crane.



WARNING

Tipping/Overload Hazard!

Avoid tipping crane over or collapsing mast:

- Assemble and disassemble crane on a firm, level, uniformly supporting surface.
- Do not exceed swing limits and mast lifting capacities given in Table 4-1.
- Keep crane level when operating carbody jacks.



WARNING

Avoid Falling Off Crane and Boom!

It is necessary to climb onto crane and boom during assembly and disassembly steps.

Use sturdy owner furnished ladders or an approved personnel hoist to gain access to areas which cannot be reached from ladders or steps provided with crane.



WARNING

Moving Parts/Pinch Points!

Avoid death or crushing injury during crane assembly and disassembly:

- Assembly personnel — take every precaution to prevent injury when working near moving parts.
- Maintain communication between operator and assemblers to avoid accidents.
- Do not raise or lower gantry and mast until all personnel are off crane.
Keep unauthorized personnel well clear of crane.



WARNING

Falling Load Hazard!

To prevent lifting equipment from failing and load from dropping, crane owner/user shall verify following prior to each lift:

- All lifting equipment (shackles, hooks, slings, blocks) have been properly maintained and are safe for use.
- All lifting equipment has a capacity equal to or greater than load to be lifted.

CRANE ORIENTATION

The terms RIGHT, LEFT, FRONT, REAR used in this section see the operator's right, left, front, and rear sides when seated in the operator's cab looking forward with the crawler motors to the rear.

SELF-ERECTING EQUIPMENT

The Model 777 is a self-erecting crane equipped with the following components for assembly and disassembly:

- Carbody jacks with pads for lifting the crane onto and off the trailer. The jacks are controlled by handles located on the front of the carbody.
- Hydraulically actuated pins for connecting and disconnecting the crawlers to and from the carbody. These pins are controlled by handles located on the front of the carbody.
- Boom butt and wire rope guide which can be used as a boom to handle the crane's crawlers, counterweights, and boom sections.

- Counterweight handling pendants and counterweight pivot frame for installing and removing the counterweights.
- Counterweight installation and removal can be controlled by the counterweight remote control (in setup mode) or by the boom hoist control located in the cab.
- 30 USt (27 t) load block and 4-leg chain sling with hooks for handling parts.

ASSEMBLY AND DISASSEMBLY NOTES

The crane, boom, and jib shall be assembled and disassembled by experienced personnel trained in erection and operation of construction cranes.

Read and become thoroughly familiar with the instructions in the applicable capacity charts, in this section, and in the rigging drawings at the rear of this section before attempting to assemble or disassemble the crane, boom, or jib.

Contact your Manitowoc dealer for assistance if any procedure is not fully understood.

ASSEMBLY AND DISASSEMBLY AREA

Select an assembly/disassembly area that has a firm, level, uniformly supporting surface. Make sure the area is large enough to accommodate the crane, the selected boom and jib length, movement of trucks with trailers, and movement of the 777 (or assist crane).

Set the carbody jack pads on a flat, firm foundation that will support the load placed on them. The maximum load on each jack is 70,000 lb (31 752 kg).

Do not set the jack pads in holes, on rocky ground, or on extremely soft ground.

If necessary, use wood blocking or steel plates under the jack pads to properly distribute loading. Blocking or steel plates must be:

- Free of defects.
- Strong enough to prevent being crushed or bent.
- Of sufficient size to prevent settling under load.

Contact Manitowoc Product Support for ground bearing information.

ACCESSING PARTS

Some parts of the crane, boom, and jib cannot be reached from the ground. Take necessary precautions to prevent falling off the crane or boom during assembly and disassembly.

Owner/user shall provide approved ladders or personnel hoists so workers can safely access those areas of crane, boom, and jib that cannot be reached from ground. Adhere to local, state, and federal regulations for handling personnel.

Optional boom ladders (stored in boom butt) are available from Manitowoc. If your crane has ladders, see instructions later in this section.

CRANE WEIGHTS

See Crane Weights in Section 1 for overall weight of the crane and individual weights of components.

RETAINING CONNECTING PINS

Connecting pins are retained in various ways:

- Snap pins.
- Quick-release pins.
- Cotter pins.
- Keeper plates with cap screws and lock washers.

Do not operate crane until all connecting pins are installed and properly retained.

COLD WEATHER MAST OPERATION

The mast, mast cylinders, and mast arms can be damaged when attempting to lower the mast during cold weather.

Do not attempt to lower the mast during cold weather until the following steps have been performed:

- Hydraulic oil warmed up to at least 60°F (16°C).
- Mast cylinders fully extended and retracted twice to fill cylinders with warm oil.

NOTE: To check hydraulic fluid temperature, observe HYD TANK FLUID TEMP on the digital display in the operator's cab.

LOWERWORKS LUBRICATION AT ASSEMBLY

Each time the crawlers are assembled to the carbody, thoroughly clean and apply Never-Seez® or equivalent anti-seizing compound to all machined surfaces on the carbody and the crawlers — surfaces marked → in Figure 4-1.

If this step is not performed, excessive friction will occur in the closely machined mating surfaces between the crawlers and the carbody. The result will be loud noises coming from the lowerworks when turning (cutting) the crawlers or swinging the upperworks over the corner of the crawlers.

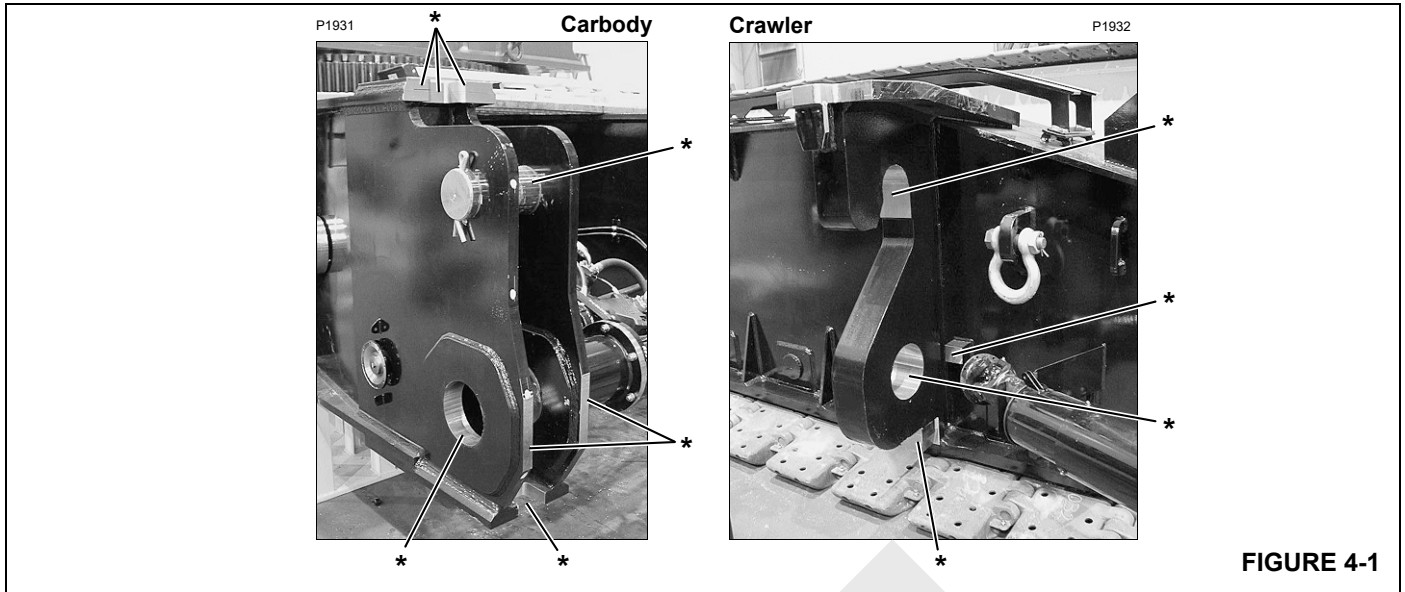

FIGURE 4-1

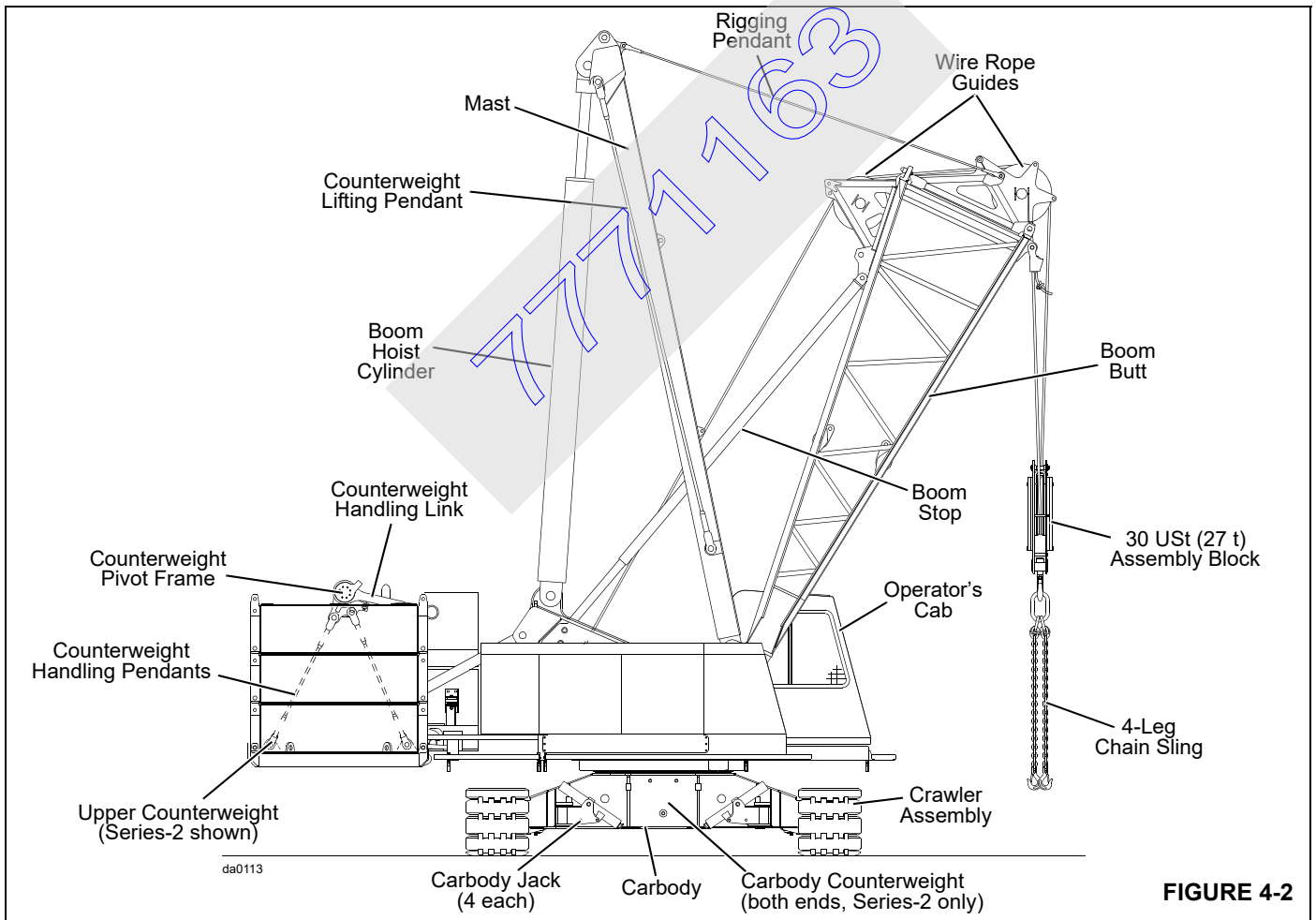
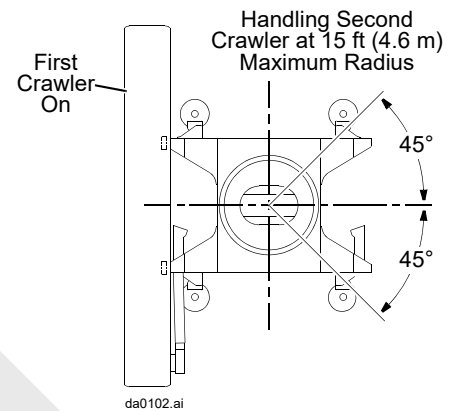

FIGURE 4-2

OPERATING LIMITATIONS

Table 4-1
Swing and Capacity Limitations During Erection

Crane Configuration	Swing Limitations	Capacity Limitations*
Crane on Jacks (No Crawlers) Boom Butt in Transport Position No Counterweight Installed	360° Swing Permitted	Load Handling NOT ALLOWED When Crane Is In This Configuration
Crane on Jacks (No Crawlers) Boom Butt Fully Raised No Counterweight Installed	360° Swing Permitted	15 ft (4.6 m) Maximum Radius 40,000 lb (18 144 kg) Maximum Load
Crane on Jacks Installing Crawlers with Boom Butt No Counterweight Installed	Handling First Crawler: • 360° Swing Permitted	Handling First Crawler: • 15 ft (4.6 m) Maximum Radius
	Handling Second Crawler: • 45° Swing Permitted	Handling Second Crawler: • 15 ft (4.6 m) Maximum Radius • First Crawler Installed
Crane on Crawlers Handling Loads with Boom Butt Counterweight Installed or Removed	360° Swing Permitted	26 ft (7.9 m) Maximum Radius 40,000 lb (18 144 kg) Maximum Load



* 40,000 lb (18 144) capacity is for a 2-part line and includes weight of wire rope, load block, and lifting slings.

OPERATING CONTROLS

See Section 3 for identification and operation of all controls.

- The carbody controls (crawler pins and carbody jacks) are operable any time the engine is running.
- To operate the mast as a boom using the boom hoist handle, the crane CRANE SETUP mode must be selected and confirmed.
- To operate the switches on the remote control (counterweight, boom butt, etc.) SETUP REMOTE mode must be turned ON and confirmed. *The mast is still operable in this mode.*

Turn off SETUP REMOTE mode to prevent accidental operation of remote switches when remote control is not in use.

SHIPPING CRANE COMPONENTS

To ensure the crane's self-erecting system can load and unload the carbody and upperworks assembly, the trailer must meet the specifications given in Figure 4-3.

It is the owner/user's responsibility to ensure the following:

- That all trailer loads comply with local, state, and federal transportation requirements.
- ***That all crane components are properly blocked and secured so they cannot shift or fall off trailers.***
- To avoid damage to components:

Use nylon tie-downs to secure components as shown in Figure 4-3, View A.

If chain tie-downs are used, install protective covering (such as sections of rubber tire) between the chain and component being secured as shown in Figure 4-3, View B.

When securing boom sections, wrap tie-downs over chords — never over lacings. Keep tie-downs as close to blocking as possible (View A) to prevent bending the chords.

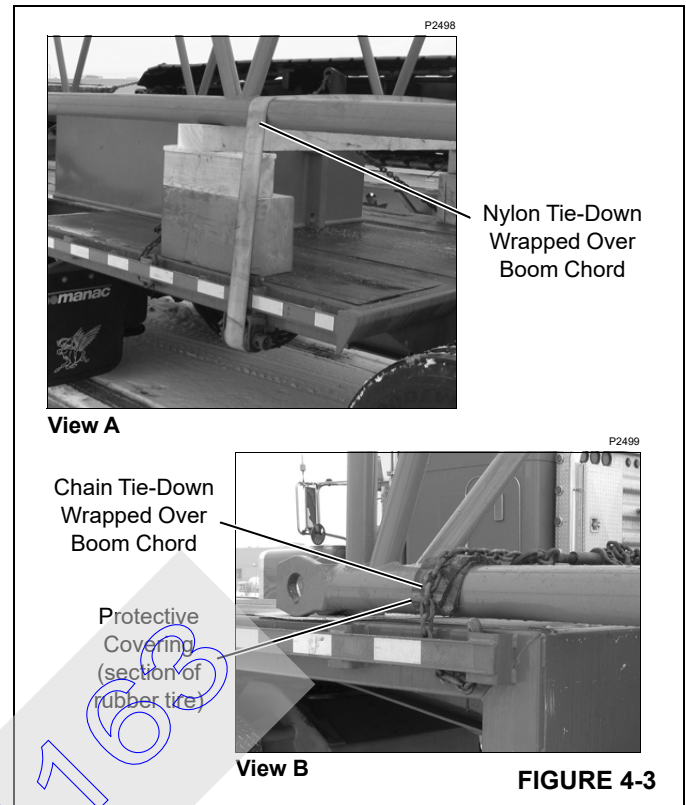

THIS PAGE INTENTIONALLY LEFT BLANK

777163

CRANE ASSEMBLY

Pre-Start Checks

Make the following checks before starting the engine upon arrival at the assembly site. See Section 3 for starting instructions.

Engine

1. Check for leaks.
2. Check fuel, oil, and coolant levels.
3. Repair or refill as required.

Gear Boxes

1. Check for leaks.
2. Check levels.
3. Repair or refill as required.

Hydraulic System

1. Check for leaks.
2. Check level.
3. Repair or refill as required.
4. Make sure shut-off valves are open.

Remove Crane from Trailer

! WARNING
Moving Part Hazard!

Avoid serious crushing injury. Warn all personnel to stand clear of jacks.

Tipping Hazard!

Keep crane level while jacking. A 2-way level is provided near controls on front of carbody (Figure 4-5, View D).

See Figure 4-4 for following steps.

1. Untie crane from trailer.
2. Raise and pin all catwalks in operating position (View A).
3. Check that boom angle indicator electrical cord (View B) is plugged into junction box on boom butt.
4. Check that boom electrical cord is plugged into shorting plug on boom junction box (View B).

NOTE: The boom electrical cord is plugged into junction box *only* during erection procedure. After crane is assembled, boom electrical cord must be plugged into cable reel on boom butt.

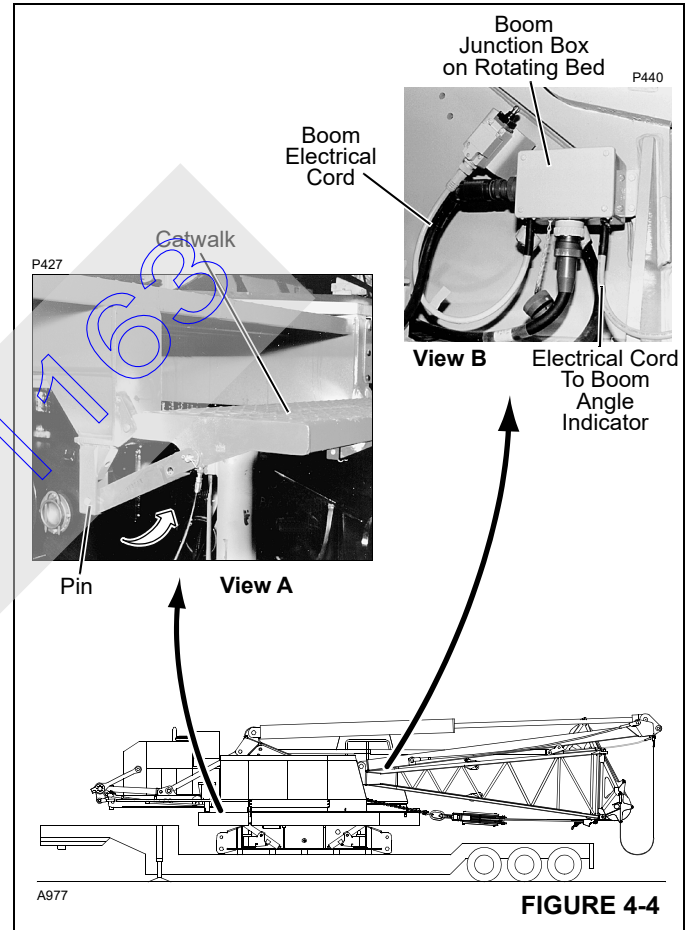

FIGURE 4-4

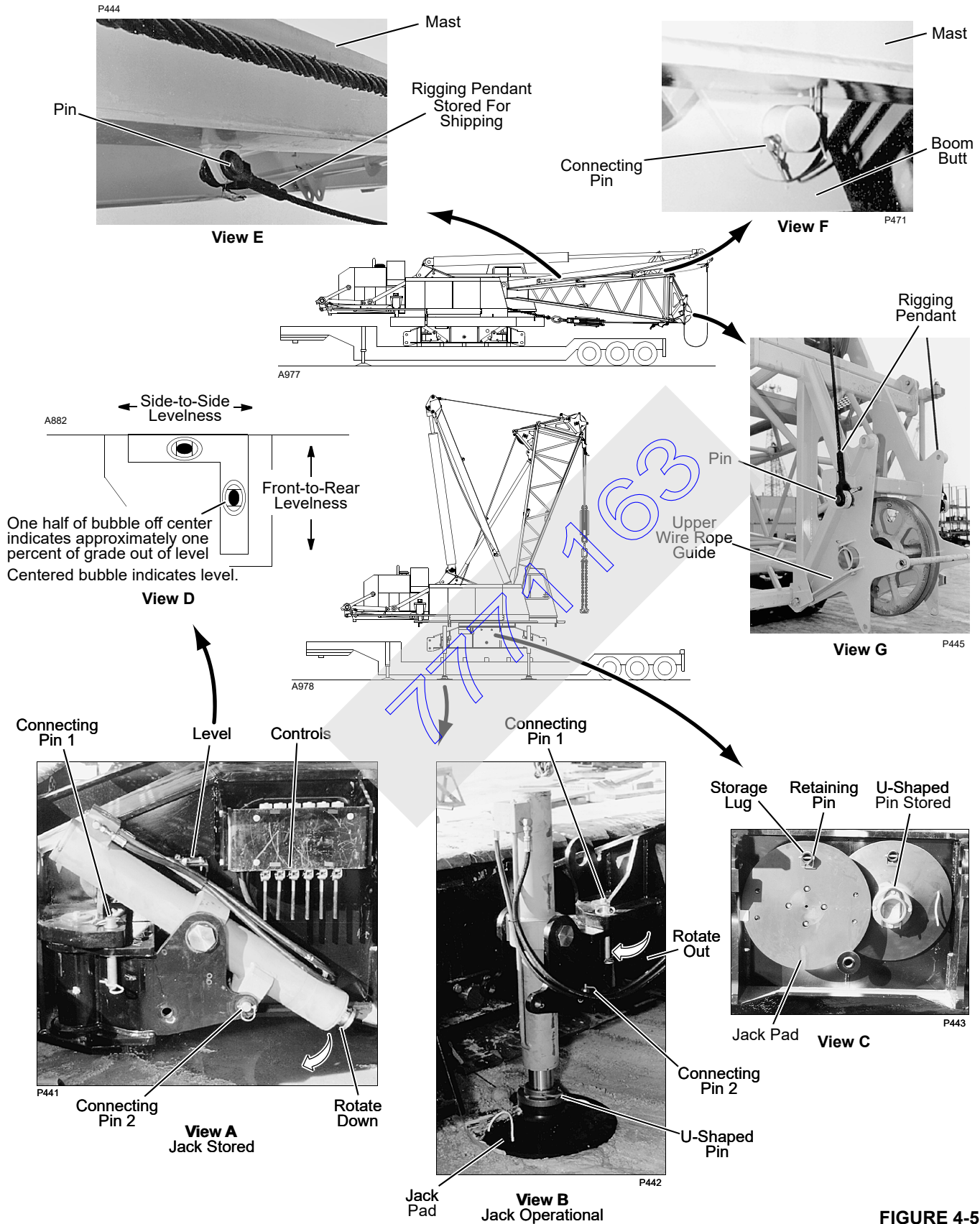

FIGURE 4-5

See Figure 4-5 for the rest of this procedure.

5. Perform pre-start checks and start engine.

NOTE: It is normal for system fault alert and operating limit alert to come on when engine is started.

The system fault alert should go off as engine oil pressure, and hydraulic oil temperature rise to normal. *If alert does not go off soon after start-up, determine fault, stop engine, and correct cause of fault* (see Digital Display Readings in Section 3 of this manual).

The operating limit alert will remain on until boom electrical cord is connected to boom junction box on rotating bed.

6. Remove mast-to-butt connecting pins (View F). Store pins in lugs on mast once mast is raised.
7. Disconnect rigging pendants from storage position on mast (View E) and connect pendants to upper wire rope guide on front of boom butt (View G).
8. Raise boom butt to desired operating position as shown in Figure 4-5. Pay out load line as butt is raised.
9. Disconnect assembly block from front of rotating bed.
10. Position each carbody jack as follows:
 - a. Remove connecting pin 1 (View A).
 - b. Rotate jack out and install connecting pin 1 (View B).
 - c. Remove connecting pin 2 (View A).
 - d. Rotate jack down and install connecting pin 2 (View B).

13. Remove blocking from between crane and trailer and slowly pull trailer out from under crane.

Operating Note

360° swing is permitted when crane is on jacks with boom butt in transport position.



WARNING

Falling Butt Hazard!

Boom butt must be supported on trailer or blocking when removing mast-to-butt connecting pins. Butt will fall if not supported when pins are removed.

CAUTION

Boom Stop Interference!

Booming above 10° with mast-to-butt connecting pins still installed will cause damage to mast cross member.

11. Remove jack pads from storage position (View C) and connect jack pad to each jack rod with U-shaped pin (View B).
12. Using controls on front of carbody (View A), extend carbody jacks fully to raise crane off trailer.

! WARNING

Tipping Hazard!

Do not exceed 15 feet (4.6 m) radius while lifting either crawler. Crane will tip.

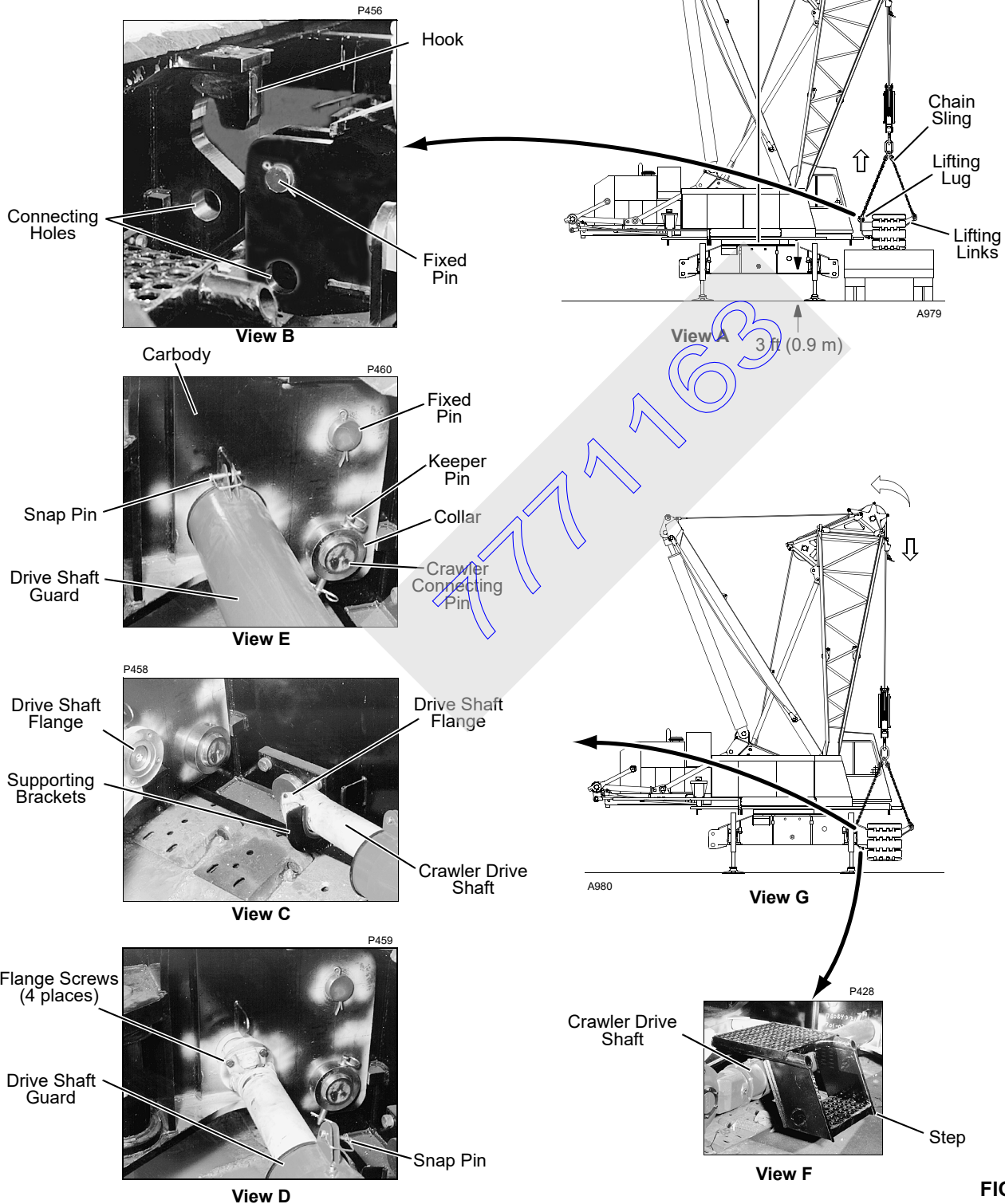

FIGURE 4-6

Install Crawlers



DANGER

Tipping Hazard!

Prevent crane from tipping over:

- Make sure crane is level. Check 2-way level on front of carbody. Adjust jacks as required.
- Do not exceed 15 ft (4.6 m) radius while lifting either crawler (Figure 4-7).

CAUTION

Parts Damage!

Avoid hitting carbody jacks with crawlers.

See Figure 4-6 for following procedure unless otherwise indicated.

1. Position trailer with crawler along desired side of crane (View A).

NOTE: Make sure drive shafts are positioned at the rear of the carbody (opposite carbody controls).

2. Remove keeper pins and collars from crawler connecting pins (View E). Use handle on carbody remote control to retract pins.
3. Attach three hooks from chain sling to lifting lug on inboard side of crawler and lifting links on outboard side of crawler (View A).
4. Slowly hoist crawler clear of trailer and remove trailer.
5. Slowly lower crawler, boom up, and swing to engage hooks on crawler with fixed pins on carbody wings (View B).
6. STOP lowering and booming when crawler hooks are engaged with fixed pins and connecting holes are aligned (View B).
7. Engage crawler connecting pins with holes and install collars and keeper pins (View E).
8. Lift crawler drive shaft off supporting bracket (View C), extend shaft, and align holes in drive shaft flanges (Views C and D).
9. Insert flange screws and torque to 74 ft-lb (100 N-m) (View D).
10. Slide drive shaft guard over drive shaft (View E) and pin guard to carbody.
11. Unhook chain sling from crawler.
12. Swing over other side.



WARNING

Rotating Drive Shaft Hazard

Crawler drive shaft rotates at high speed. To prevent death or serious injury:

- Make sure drive shaft is securely attached at both ends.
- Make sure guards are in place and securely attached at both ends during operation.
- Do not attempt to service drive shaft until crane has been parked and engine stopped.

13. Repeat steps 1 through 10 for other crawler



DANGER

Tipping Hazard!

Do not allow assembly block to swing past inside edges of carbody jacks (Figure 4-7) while installing second crawler. Crane will tip.

14. Slowly rotate crawlers (travel forward and back) to center treads on rollers.
15. Lower carbody until crawlers are on ground. KEEP CRANE LEVEL. Then fully retract jacks.
16. Remove jack pads and store (Figure 4-5, View C).
17. Position each carbody jack as follows:
 - a. Remove connecting pin 2 (Figure 4-5, View B).
 - b. Rotate jack up and install connecting pin 2 (Figure 4-5, View A).
 - c. Remove connecting pin 1 (Figure 4-5, View B).
 - d. Rotate jack in and install connecting pin 1 (Figure 4-5, View A).
18. Install step (Figure 4-6 View F) at front and rear inboard side of both crawlers.

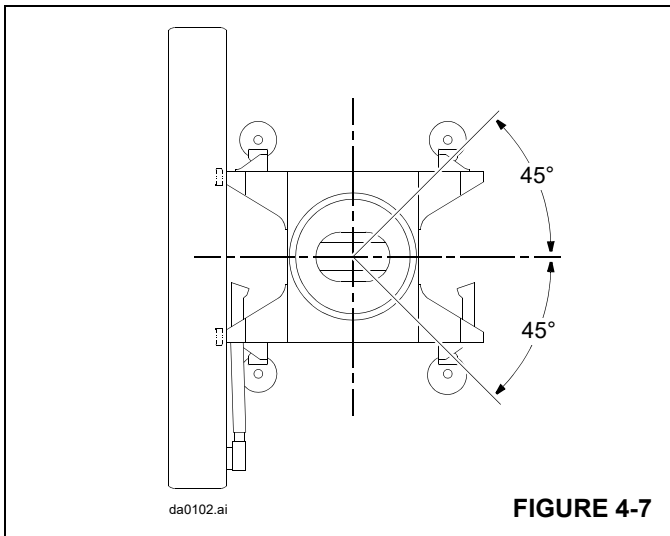

Install Counterweights

The crane rotating bed must be in-line with carriage while installing upper counterweight (360° swing is permitted while assembling counterweights and installing carbody counterweights).



WARNING

Tipping Crane Hazard!

Prevent crane from tipping while assembling counterweights:

- Do not exceed 26 ft (7.9 m) radius.
- Do not lift more than 40,000 lb (18 144 kg). Tipping or structural damage may occur.
- Install Series-2 counterweight in exact sequence given in this procedure and shown in Figure 4-9, View A.

Avoid dropping counterweights during assembly:

- Do not lift lower tray and side boxes as a unit. Lifting lugs may break.
- Do not lift more than two side boxes at a time. Lifting lugs may break.

1. Check that both counterweight limit switches are properly installed at rear of crane and operational. Test both limit switches as instructed in Counterweight Limit Switch Adjustment in Crane Service Manual.
2. Assemble upper counterweights as shown in Figure 4-8, Views A and B:

- a. Lift lower tray onto ground and level it with blocking. Lift at four lifting lugs on lower tray (Figure 4-8, View A or B).

NOTE: Rollers on lower tray must face crane.

- b. Lift side boxes into position and pin to lower tray (Figure 4-8, View A-A) — lift at connecting pins
- c. Lift remaining side boxes into position and pin to each other (Figure 4-8, View A-A).
- d. On current production cranes using Model 888 or 999 side boxes, **be sure to pin steel plates to both top side boxes (Figure 4-8, View B).**



WARNING

Tipping Crane Hazard!

Prevent crane from tipping on current production cranes using Model 888 or 999 side boxes:

- Pin steel plates to both top side boxes as shown in Figure Figure 4-8, View B.

da0103

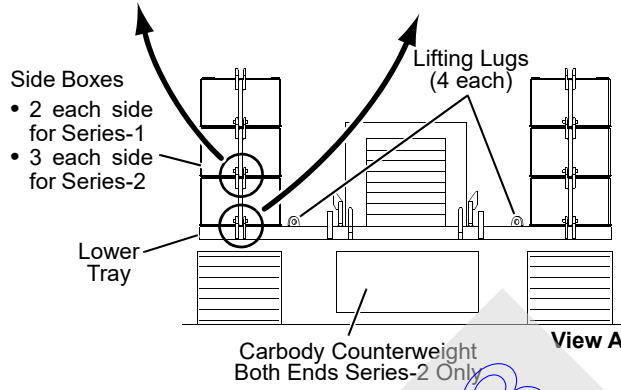
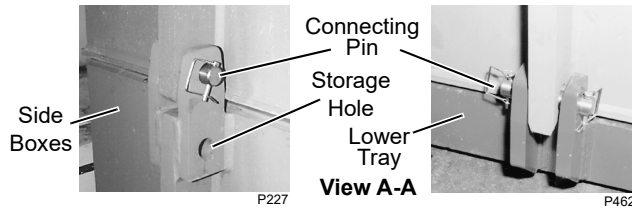

PAST PRODUCTION

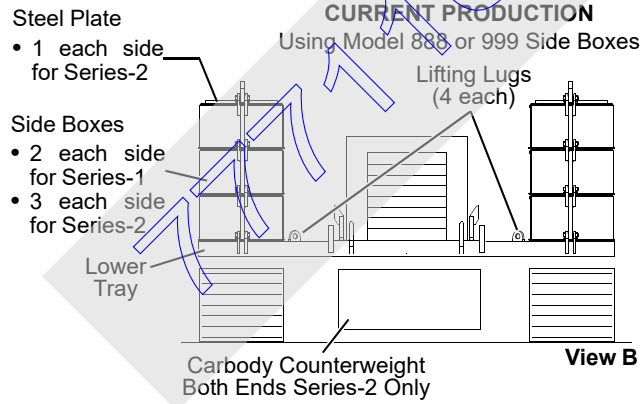

CURRENT PRODUCTION

Using Model 888 or 999 Side Boxes

4

FIGURE 4-8

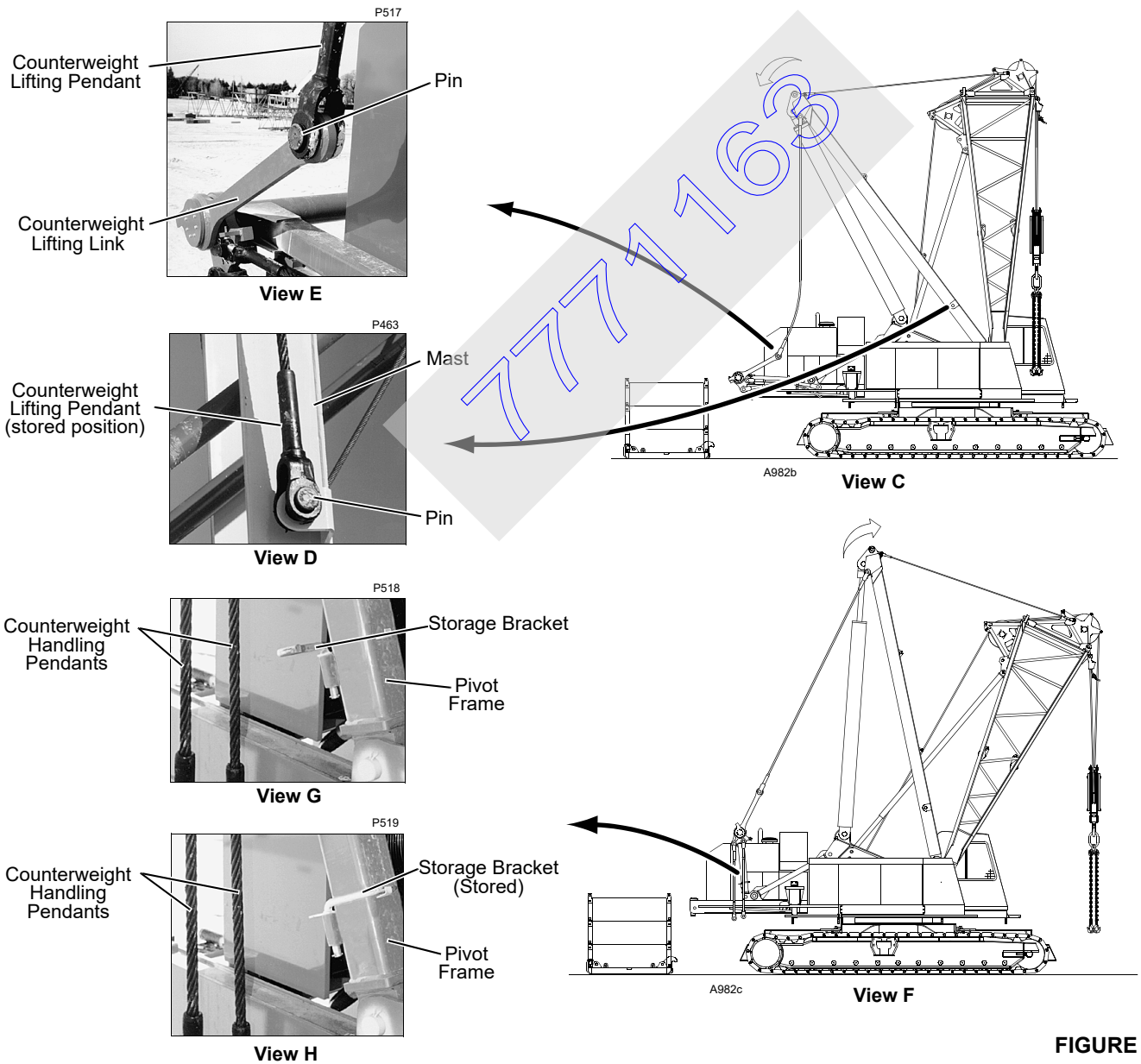
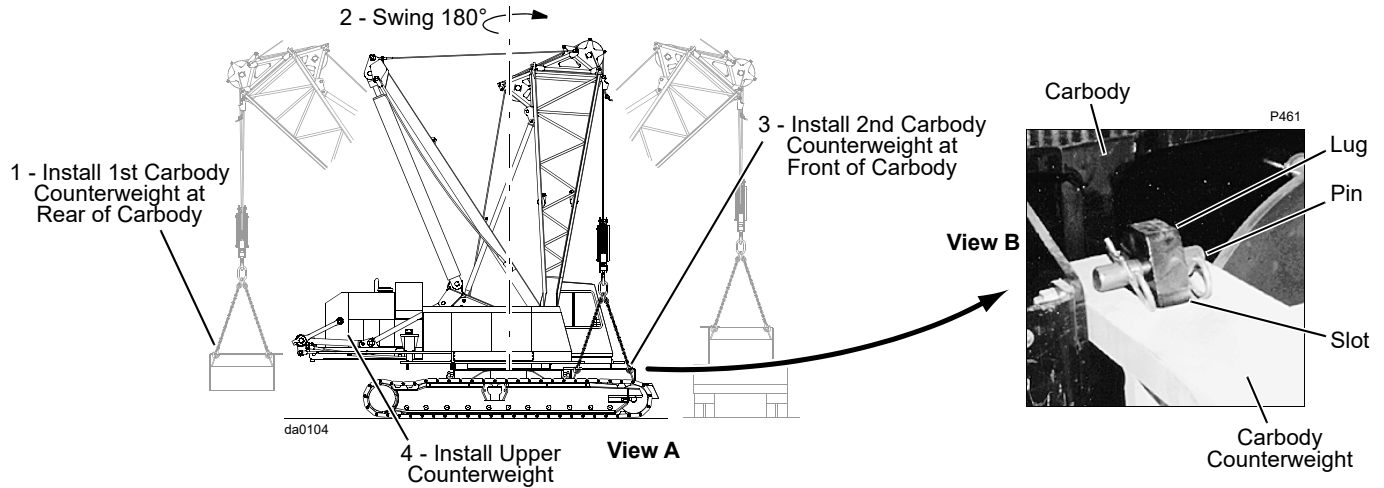
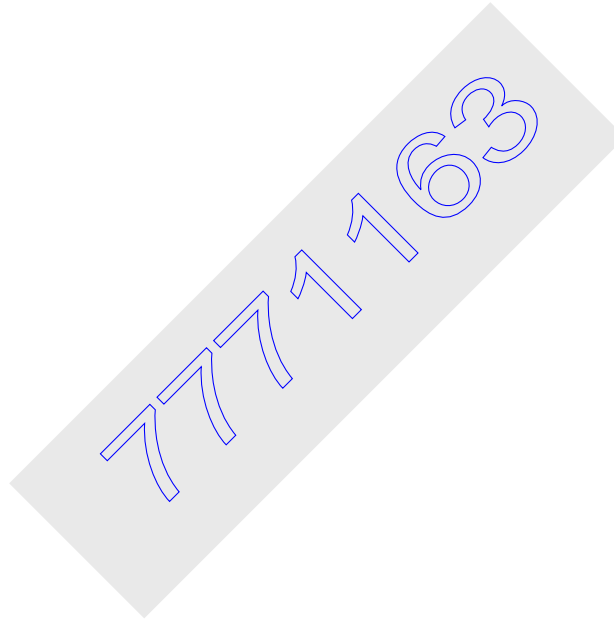
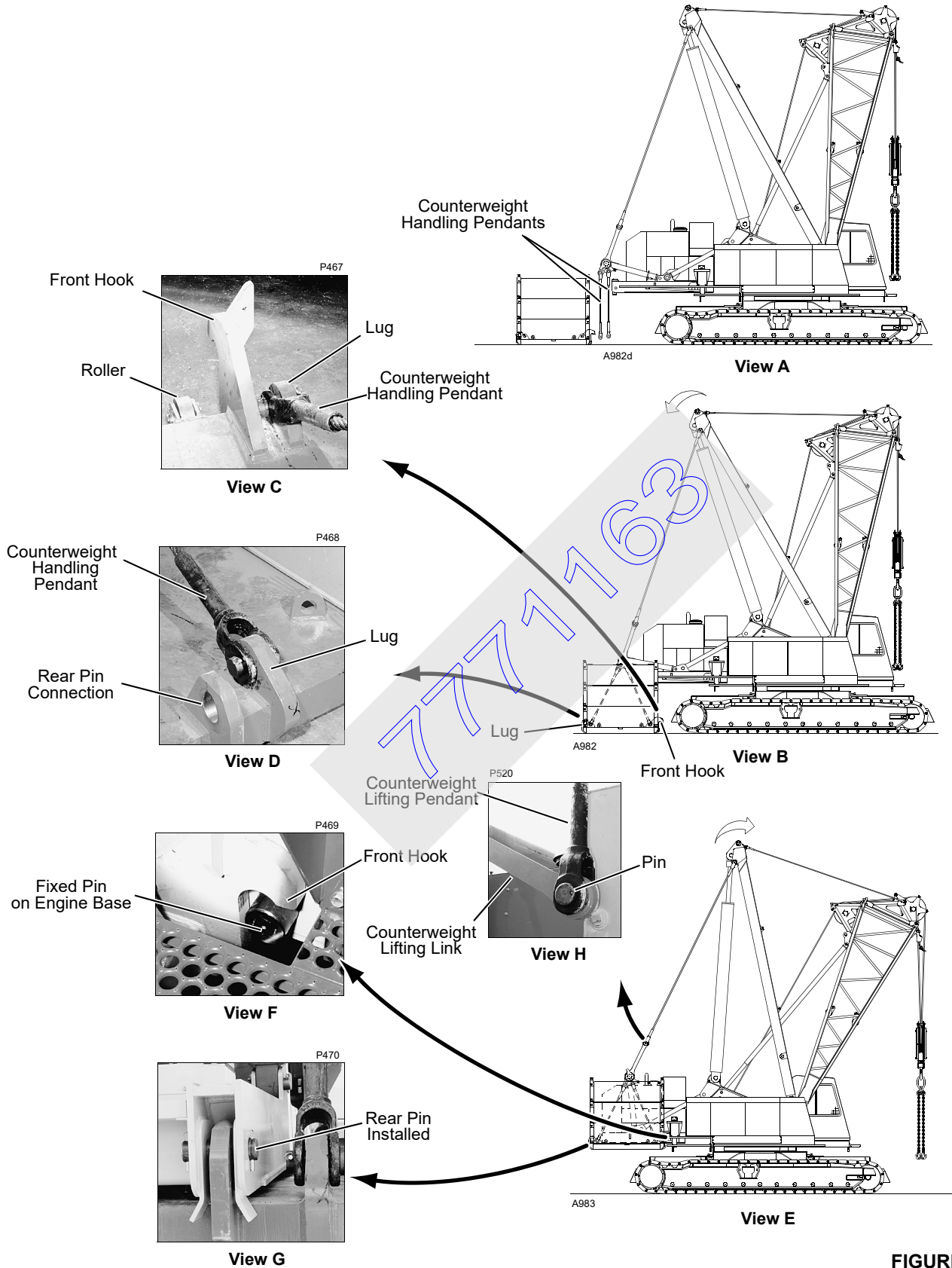

FIGURE 4-9

3. If crane will be equipped with Series-2 counterweight, install carbody counterweights as follows, before installing upper counterweight. If not, go to step 4.
 - a. Hook onto carbody counterweight with chain sling and lift into position at rear end of carbody — lift at four lifting lugs (Figure 4-9, View A).
 - b. Boom, swing, and hoist as required to engage slots in counterweight with lugs on carbody (Figure 4-9, View B).
 - c. Lower counterweight and disconnect chain sling.
 - d. Install pins (Figure 4-9, View B) to connect carbody counterweight to carbody.
 - e. Swing 180° and repeat steps 3a – 3d for front carbody counterweight.
 4. Raise boom until mast is vertical.
 5. Disconnect counterweight lifting pendants from storage position on mast (Figure 4-9, View D). Same pins are used in step 7.
 6. Raise boom butt until lifting pendants can be connected to counterweight lifting links (Figure 4-9, View C).
 7. Pin counterweight lifting pendants to links (Figure 4-9, View E).
 8. Lower boom butt until pivot frame is near vertical (Figure 4-9, View F).
 9. Unhook counterweight handling pendants from storage position (Figure 4-9, View G).
 10. Fold counterweight handling pendant storage brackets to storage position (Figure 4-9, View H).
- NOTE:** Use the boom hoist control in cab for steps 4 – 11.





11. Raise boom butt until handling pendants are hanging approximately 6 in. (152 mm) above ground (Figure 4-10, View A).

12. Position crane so it is in-line and centered with upper counterweight assembly (Figure 4-10, View B).

NOTE: Select and confirm SETUP mode. Use the remote control for steps 13 – 16.

The remote controller has sufficient cable to allow operator to stand alongside rear of crane and closely observe operation



WARNING

Falling Load Hazard!

Always stand to side of counterweight while handling it. Do not stand between counterweight and rear of crane while handling counterweight. Never go under counterweight unless counterweight is securely pinned in place.

13. Connect counterweight handling pendants to lugs on counterweight tray (Figure 4-10, Views C and D).

14. Raise counterweight until front hooks on counterweight tray engage fixed pins on engine base (Figure 4-10, View F).

NOTE: The front end of the counterweight rises first. The rollers on the counterweight tray roll along the engine frame and guide the counterweight up until the front hooks engage the fixed pins on the engine base.

15. Continue to raise counterweight until rear holes line up.

16. Install rear pins between engine base and counterweight tray (Figure 4-10, View G).

NOTE: Select and confirm STANDARD mode and use boom hoist control in cab for remaining steps. Store the remote control.

17. Raise boom butt until counterweight lifting links are fully lowered (Figure 4-10, View H).

18. Disconnect counterweight lifting pendants from counterweight lifting links (Figure 4-10, View H). Same pins are used in step 20.

19. Lower boom butt until mast is vertical.

20. Pin counterweight lifting pendants to mast for storage (Figure 4-9, View D).

Assemble Boom

Assemble the desired boom and jib combination as instructed in the Rigging Guides in this section.

The crane must be in the following configuration to assemble its own boom and jib:

- Crane rigged as shown in Figure 4-2.
- Radius limited to 26 ft (7.9 m).
- Capacity limited to 40,000 lb (18 144 kg).



DANGER

Falling Load Hazard!

Prevent crane from tipping or structural damage to components:

- Do not exceed 26 ft (7.9 m) radius.
- Do not lift more than 40,000 lb (18 144 kg).

Connect Boom Butt To Boom

The boom sections have FACT™ connectors:

- The top connectors are joined by fixed vertical pins that hook into holes in the adjacent section (Figure 4-12, View B).
- The bottom connectors are joined by removable horizontal pins (Figure 4-12, View C).

1. Remove assembly block:

- a. Disconnect wire rope from socket and wedge on boom butt.
- b. Remove wire rope from assembly block and tie off wire rope to upper wire rope guide.
- c. Remove and store assembly block.

2. Lower butt onto blocking approximately 15 in. (381 mm) high (Figure 4-11).

3. Unpin upper wire rope guide from end of boom butt (Figure 4-11, View A). Use same pins in step 4.

4. Raise mast (boom up) until upper wire rope guide is fully raised. Pin upper wire rope guide to lower wire rope guide (Figure 4-11, View B).

NOTE: Install rope guide bar in proper holes as shown in Figure 4-11, View B.

5. Position crane so boom butt is in-line with boom (Figure 4-12, View A).
6. Travel forward slowly, swing, and boom up and down as required to align fixed vertical pins in butt with top connector holes in insert (Figure 4-12, View B).

! WARNING
Tipping Hazard!

Prevent crane from tipping:

- Block crawlers if required per capacity chart before attempting to raise boom.

7. Check appropriate capacity chart to see if crawlers must be blocked to raise boom. If so, proceed as follows:
 - a. Mark ground at center of both front rollers or rear tumblers, depending on which end is closer to boom.
See Crawler Blocking Diagram in Capacity Chart Manual for blocking requirements.
 - b. Lower boom to disengage top connecting pins.
 - c. Slowly travel several feet in reverse.
 - d. Place required blocking on ground at points marked in step 7a (Figure 4-12, View A).
 - e. Repeat step 6 while traveling onto blocking.
8. Slowly boom up only enough to align bottom connector holes in butt with bottom connector holes in insert (Figure 4-12, View C).

! WARNING
Moving Part Hazard!

Prevent serious crushing injury:

- Do not stand inside boom while installing connector pins — STAND OUTSIDE BOOM.

9. Install bottom connector pins (Figure 4-12, View C)
10. Boom down enough to slacken rigging pendants (Figure 4-12, View E).
11. Unpin rigging pendants from upper wire rope guide.

12. Pin rigging pendants to lugs on mast for storage (Figure 4-12, View F).
13. Lower mast enough to gain access to pendant links on end of mast.
14. Connect boom pendants to pendant links (Figure 4-12, View G).
15. Finish assembling boom and jib:
 - Reeve load lines to load block and/or weight ball.
 - Check that all electrical cords are connected to boom.
 - Perform pre-raising checks.
16. Connect electric cord from crane to boom:
 - a. Disconnect boom electrical cord (Figure 4-3, View B) from boom junction box on rotating bed.
 - b. Connect boom electrical cable to cable reel on boom butt.

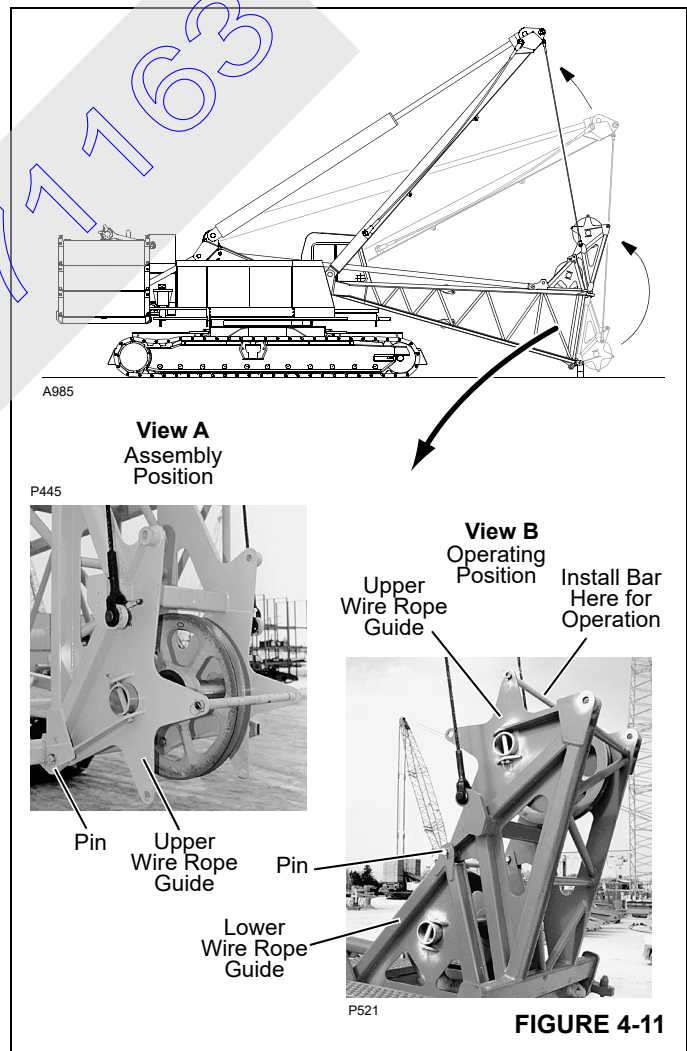

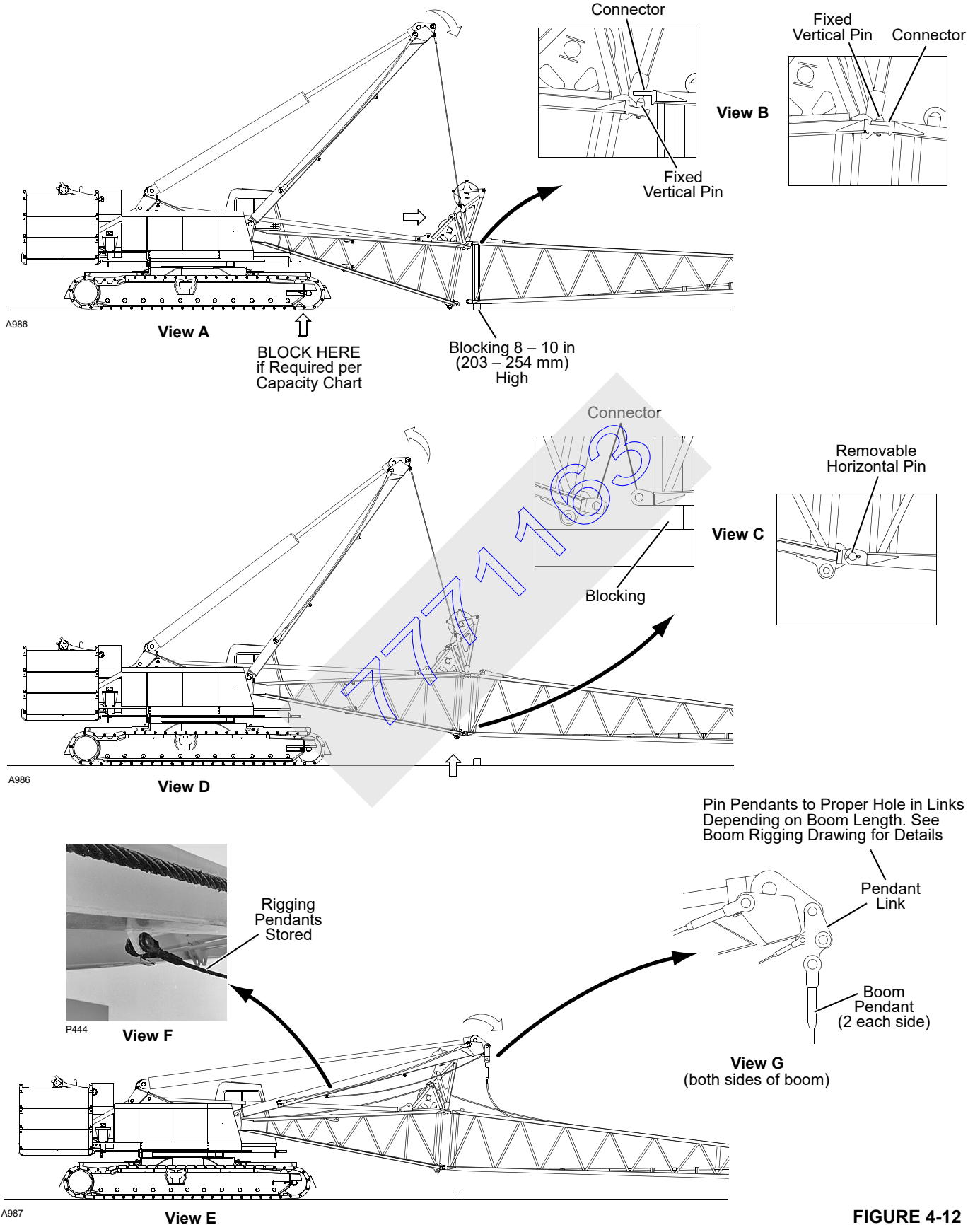

FIGURE 4-12

PRE-RAISING CHECKS

Make following checks and correct any defects before raising attachment:

- Crane is on firm, level surface.
- All connecting pins are installed and properly retained.
- Crawler locking pins are installed and properly retained.
- Carbody jack pads are stored.
- Carbody jacks are fully retracted and pinned in stored position.
- Boom and jib inserts are installed in proper sequence per rigging drawing
- Boom and jib pendants are installed in proper sequence per rigging drawing.
- All insert and pendant connector pins are installed. Cotter pins are installed and spread.
- Load lines are spooled tightly onto drums and engaged with proper sheaves. Load lines are securely anchored to wedge sockets at boom and jib point or at load block and weight ball.
- All blocking, tools, and other items are removed from boom and jib.
- Electronic boom angle indicator is properly installed and adjusted (see Boom Angle Indicator Adjustment in Section 4 of the Crane Service Manual).
- Automatic boom stop is properly installed and adjusted (see Boom Stop Adjustment in Section 4 of the Crane Service Manual).
- Block-up limit control is properly installed and operational (see Block-Up limit Adjustment in Section 5 of the Crane Service Manual).
- Rated capacity indicator/limiter is properly installed and operational (see separate Rated Capacity Indicator/Limiter Manual).
- Wind speed indicator (if equipped) is properly installed and operational.
- Crane and attachment are properly lubricated (see Lubrication Guide in Section 5 of this manual).
- Crawlers are blocked if required per capacity chart.
- Intermediate suspension (if required) is fully raised and latched in position.
- Wind is within allowable limits for operation given on capacity chart.

THIS PAGE INTENTIONALLY LEFT BLANK

777163

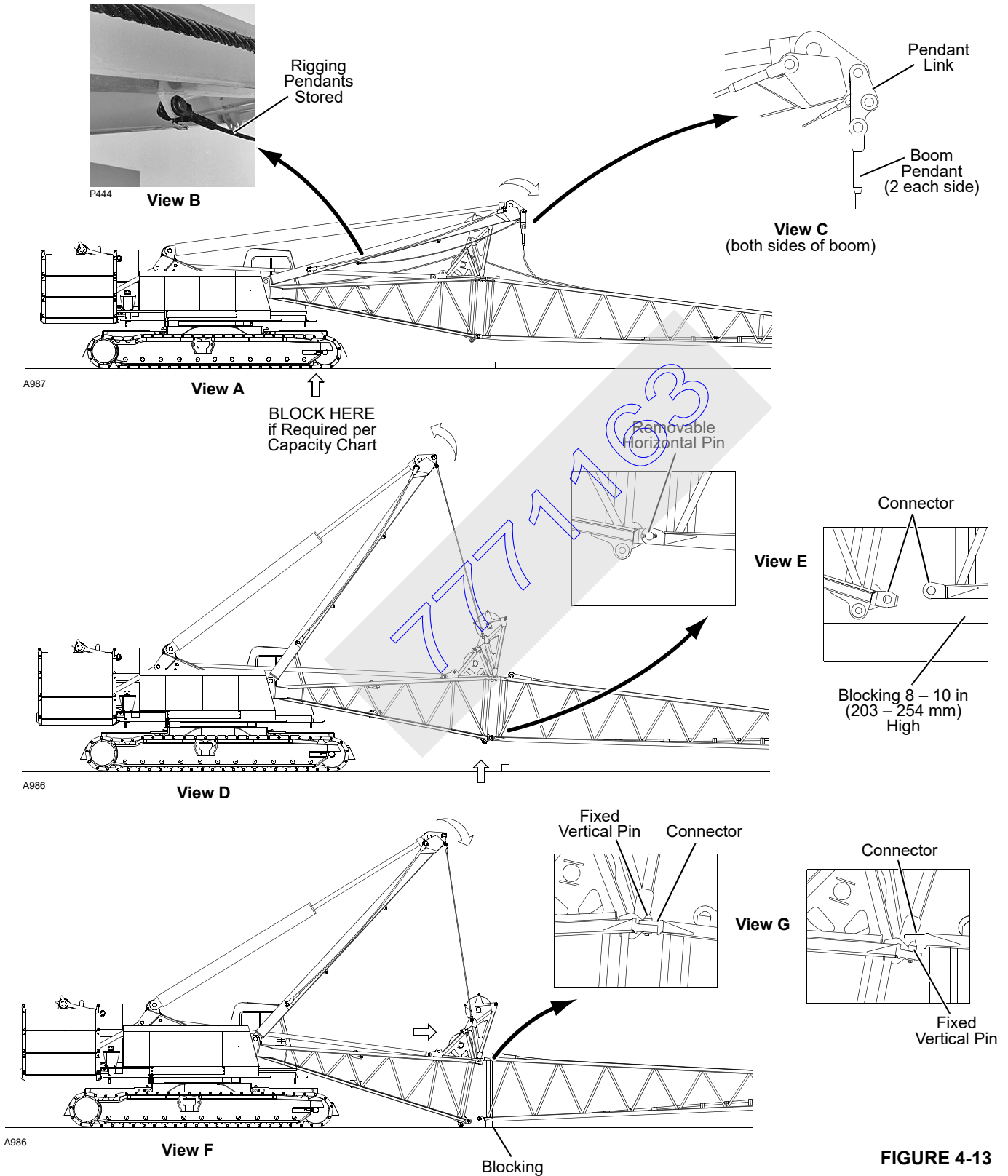

FIGURE 4-13

CRANE DISASSEMBLY

Disconnect Butt From Boom

1. Prepare crane and boom as follows:
 - a. Position crane in disassembly area.
 - b. If required per capacity chart, travel crawler front rollers or rear tumblers onto blocking (Figure 4-13, View A).
See Crawler Blocking Diagram in Capacity Chart Manual for blocking requirements.



WARNING

Tipping Hazard!

Prevent crane from tipping over:

- Block crawlers if required per capacity chart before lowering boom.

2. Lower boom and jib (if equipped) onto blocking at ground level.
 - a. If equipped with a jib, *disengage jib stop pins before jib point contacts ground or damage will result* (see Jib Rigging Guide in this section for procedure).
 - b. If equipped with an upper boom point, *remove lower connecting pins (Item B, Figure 4-28, View C) before boom point contacts ground, or damage will result.*
 - c. Place blocking approximately 6 in. (152 mm) high under bottom chords at connecting pins between top and adjacent insert as boom is lowered.
3. If equipped with intermediate suspension, lower strut as follows:
 - a. Boom up so intermediate suspension strut is in tension (Figure 4-29, View E).



WARNING

Falling Strut Hazard!

Do not attempt to remove strut latch pins until strut is in tension. Strut will drop suddenly with considerable force if this step is ignored.

- b. Remove pins to disengage inside latches from intermediate suspension beam (Figure 4-29, View F).
 - c. Slowly boom down until strut is resting in supports (Figure 4-29, View C).
4. Continue to lower mast (boom down) until boom pendants are slack (Figure 4-13, View A) and pendant links on end of mast are accessible.
5. Disconnect boom electrical cord from cable reel on boom butt and connect cord to junction box on rotating bed (Figure 4-14, View A).
6. Remove block-up limit assembly and spool electrical cord onto reel on boom butt.
7. Disconnect load lines from load block and weight ball and spool load lines onto load drums.
8. Disconnect boom pendants from pendant links (Figure 4-13, View C). Lay pendants on top of boom.
9. Unpin rigging pendants from storage position on mast (Figure 4-13, View B).
10. Connect rigging pendants to upper wire rope guide (Figure 4-14, View B).
11. Slowly raise mast (boom up) until rigging pendants are taut and bottom connector pins at boom butt are loose (Figure 4-13, View D).



WARNING

Moving Part Hazard!

Prevent serious crushing injury:

- Do not stand inside boom while removing connector pins — STAND OUTSIDE BOOM.
12. Remove bottom connector pins (Figure 4-13, View E).
 13. Slowly boom down to lower boom onto blocking 8 – 10 in. (203 – 254 mm) high (Figure 4-13, Views E and F).
 14. Continue to boom down to disengage fixed vertical pins in butt from connecting holes in adjacent boom section (Figure 4-13, View G).
 15. Slowly travel several feet in reverse.

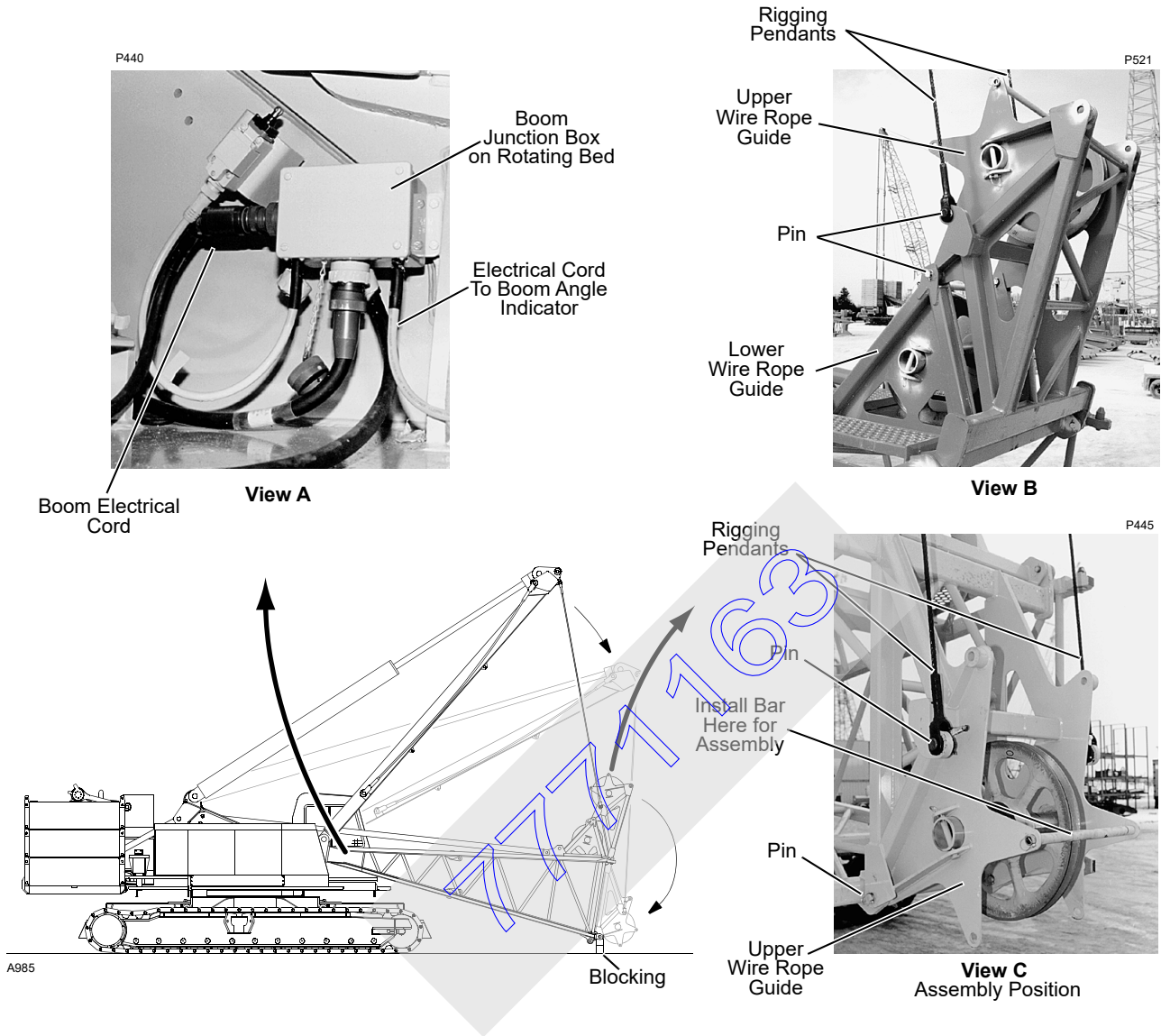

FIGURE 4-14

16. Lower butt onto blocking approximately 15 in. (381 mm) high (Figure 4-14).
17. Unpin upper wire rope guide from lower wire rope guide (Figure 4-14, View B). Use same pins in step 19.
18. Lower mast (boom down) until upper wire rope guide is fully lowered.
19. Pin upper wire rope guide to boom butt (Figure 4-14, View C).

**DANGER****Falling Load Hazard!**

Do not remove upper wire rope guide connecting pins until following steps are performed:

- Rigging pendants are securely attached between mast and upper wire rope guide.
- Rigging pendants are tensioned enough to support weight of upper wire rope guide.

Upper wire rope guide will fall violently if these steps are not performed before pins are removed.

Install Assembly Block

1. Boom down until upper wire rope guide sheave is 2 – 3 ft (0.6 – 0.9 m) off ground as shown in Figure 4-15, View A.
2. Place assembly block on ground in front of boom butt (Figure 4-15, View A).
3. Reeve wire rope from rear drum over both guide sheaves in boom butt and sheave in assembly block (Figure 4-15, View B).

NOTE: Install rope guide bar in proper holes as shown in Figure 4-14, View C.

4. Anchor wire rope to socket and wedge and connect to lug on boom butt (Figure 4-15, View C) (see Wire Rope Installation and Maintenance in Section 5 in this manual).
5. Boom up to raise boom butt to desired angle.
6. Connect 4-leg chain sling to assembly block.

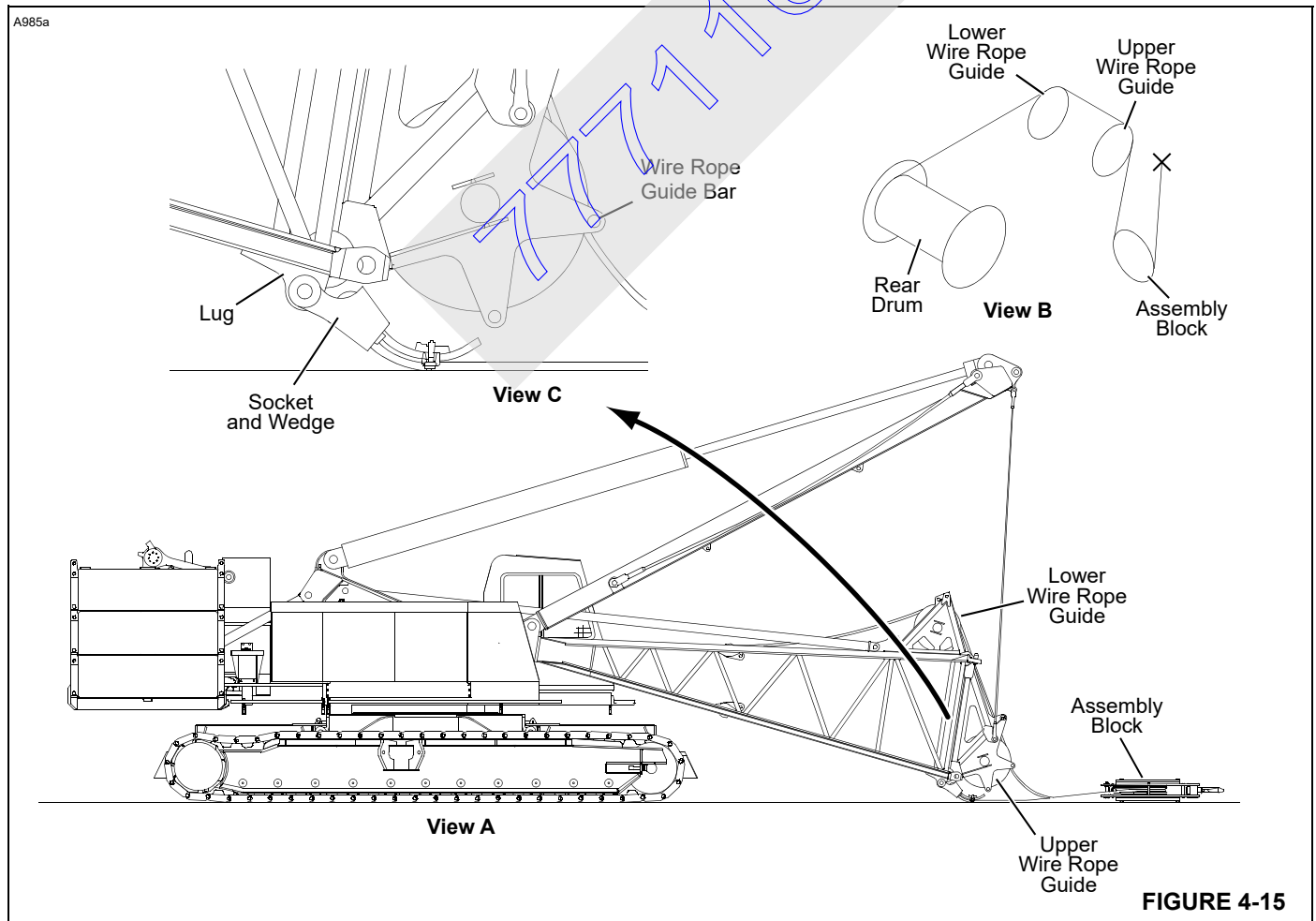

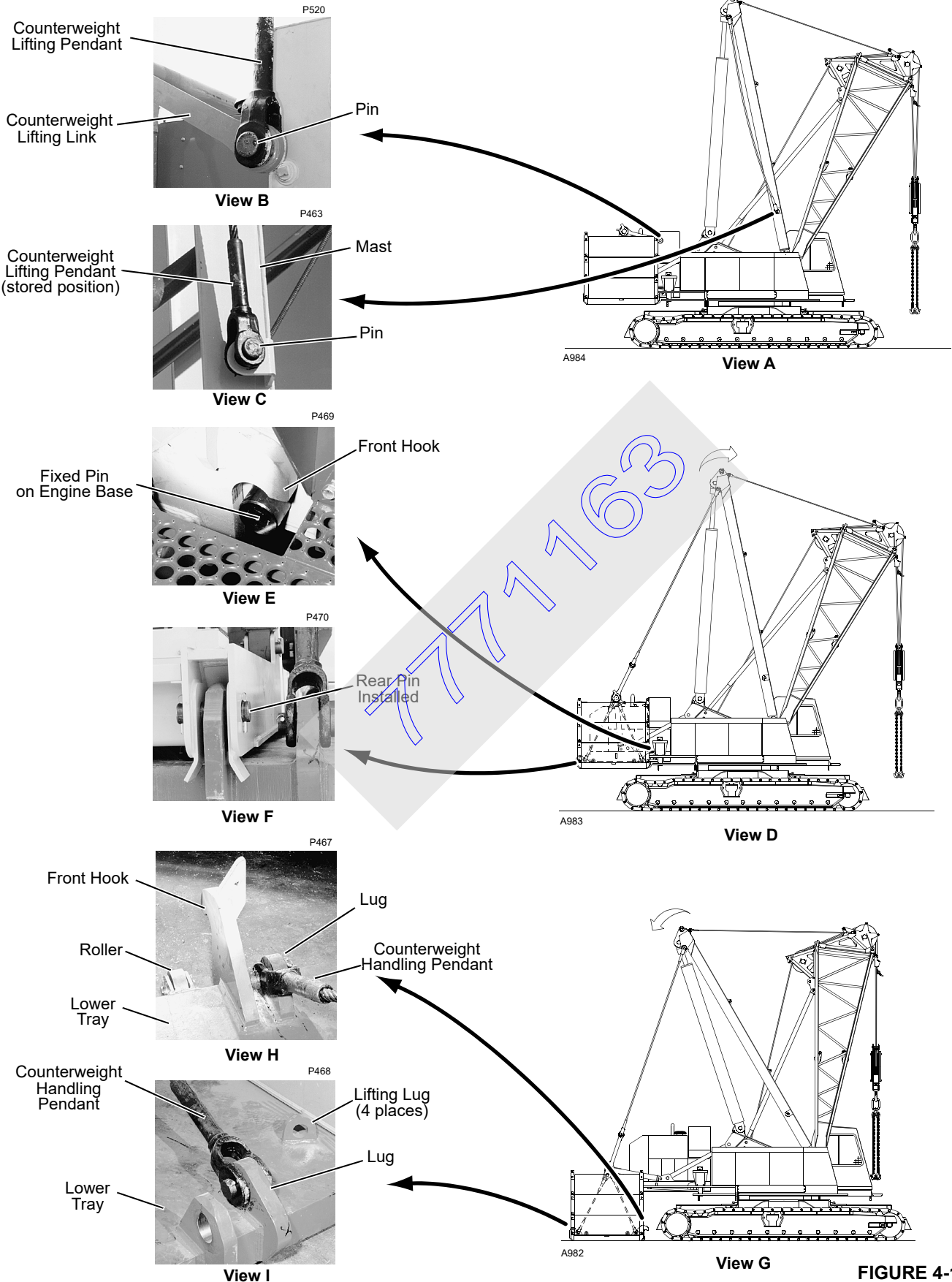

777163

FIGURE 4-16

Disassemble Boom

Disassemble the boom and jib combination as instructed in the Rigging Guides in this section.

The crane must be in the following configuration to disassemble its own boom and jib:

- Crane rigged as shown in Figure 4-16.
- Radius limited to 26 ft (7.9 m).
- Capacity limited to 40,000 lb (18 144 kg).



WARNING

Falling Load Hazard!

Prevent crane from tipping or structural damage to components:

- Do not exceed 26 ft (7.9) radius.
- Do not lift more than 40,000 lb (18 144 kg).

Remove Counterweights

See Figure 4-16 for following procedure.

The crane rotating bed must be in-line with carriage while removing upper counterweight (360° swing is permitted while disassembling counterweights and removing carbody counterweights).



WARNING

Tipping Crane Hazard!

To prevent crane from tipping, remove upper crane counterweight before removing carbody counterweights.

1. Raise boom until mast is vertical.

NOTE: Select and confirm SETUP mode. Proceed with remote control operation for steps 2 – 8.

The remote controller has sufficient cable to allow operator to stand alongside rear of crane and closely observe operation.

DANGER

Falling Load Hazard!

Always stand to side of counterweight while handling it. Do not stand between counterweight and rear of crane while handling counterweight. Never go under counterweight unless counterweight is securely pinned in place.

2. Unpin counterweight lifting pendants from storage position on mast (View C). Same pins are used in step 4.
3. Raise boom butt until lifting pendants can be connected to counterweight lifting links (View B).
4. Pin counterweight lifting pendants to links.
5. Lower boom butt until counterweight lifting links are fully raised (View D) and rear pins (View F) are loose.
6. Remove rear pins between engine base and counterweight tray (View F).
7. Lower counterweight until front hooks on counterweight tray disengage fixed pins on engine base (View E).

NOTE: The rear end of the counterweight lowers first. The rollers on the counterweight tray roll along the engine frame and guide the counterweight down.

8. Slowly lower counterweight to the ground until handling pendants are slack (View G).
9. Disconnect counterweight handling pendants from lugs on counterweight tray (Views H and I).
10. Store pins in pendant holes.

NOTE: Select and confirm STANDARD mode and use boom hoist control in cab for remaining steps. Store remote control.

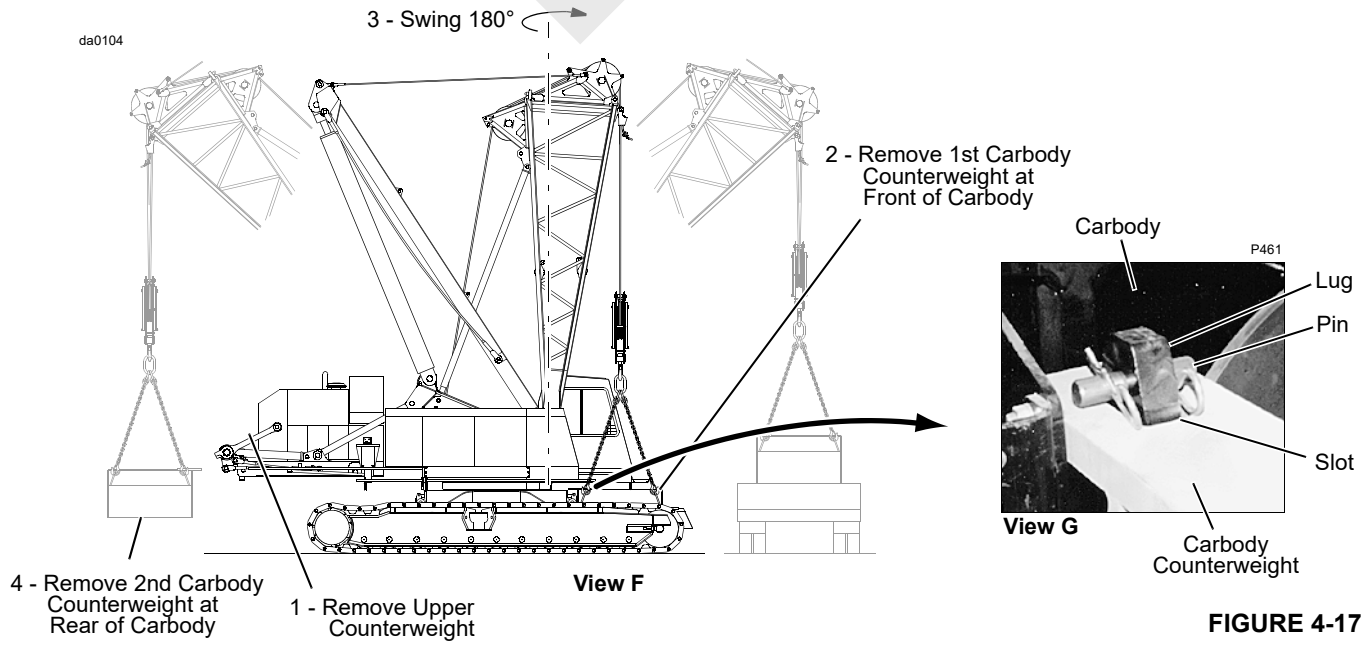
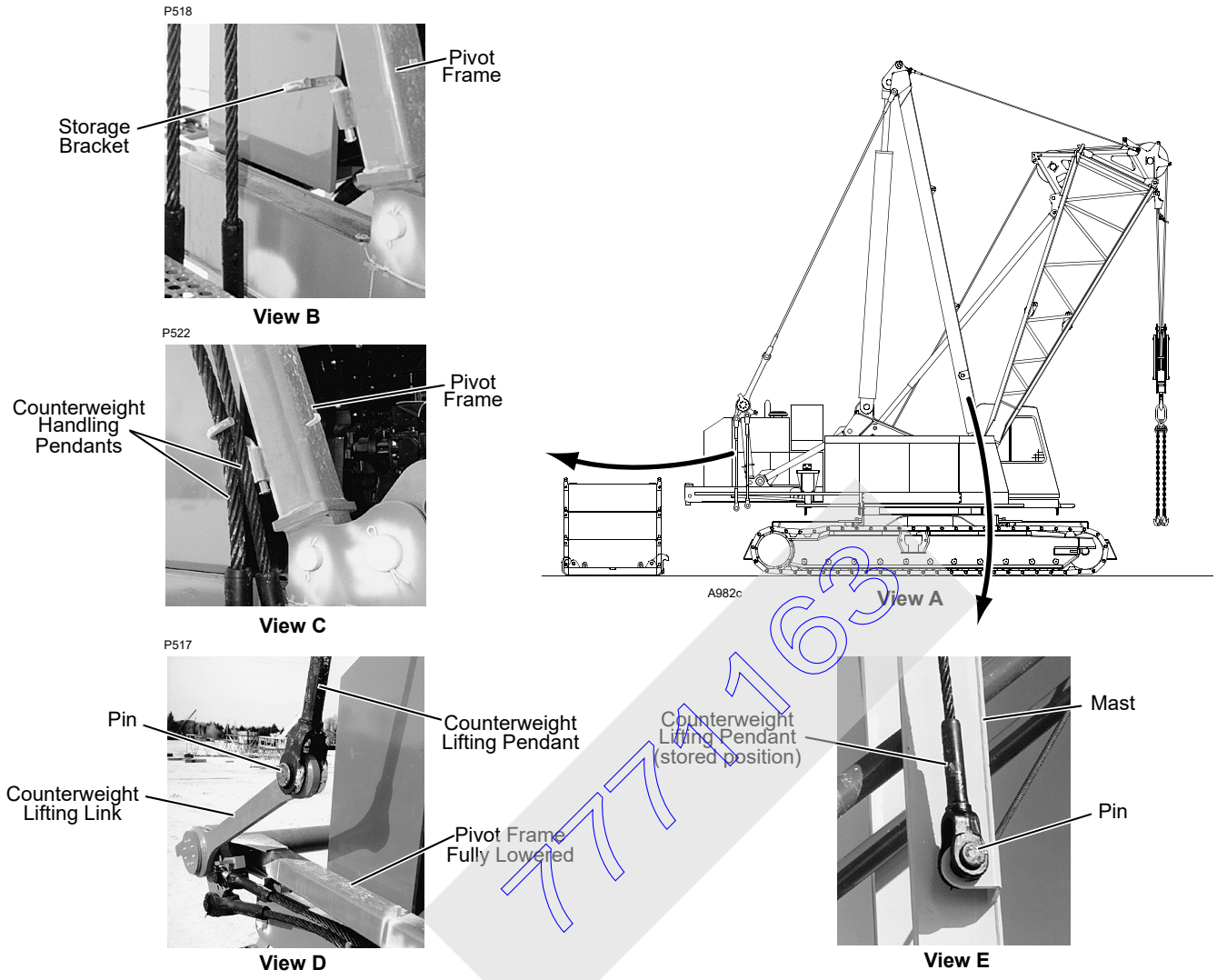

FIGURE 4-17

See Figure 4-17 for rest of this procedure unless otherwise noted.

11. Lower boom butt until counterweight pivot frame is near vertical (View A).
12. Unfold storage brackets from storage position on pivot frame (View B).
13. Hook counterweight handling pendants onto storage brackets (View C).
14. Raise boom butt until counterweight pivot frame is fully lowered and disconnect counterweight lifting pendants from lifting links (View D). Same pins are used in step 16.
15. Lower boom butt until mast is vertical.
16. Pin counterweight lifting pendants to mast for storage (View E).
17. If crane is equipped with Series-2 counterweight, remove carbody counterweights as follows:
 - a. Hook onto carbody counterweight with chain sling — lift at four lifting lugs (View F).
 - b. Remove pins (View G) connecting carbody counterweight to carbody.
 - c. Boom, swing, and hoist as required to disengage slots in counterweight from lugs on carbody (View G).
 - d. Lift carbody counterweight onto trailer and disconnect chain sling.

- e. Swing 180° and repeat steps 17a – 17d for other carbody counterweight.



WARNING **Falling Load Hazard!**

Prevent crane from tipping while disassembling counterweights:

- Do not exceed 26 ft (7.9 m) radius.
- Do not lift more than 40,000 lb (18 144 kg). Tipping or structural damage may occur.
- Remove Series-2 counterweight in exact sequence given in this procedure and shown in Figure 4-16, View G.

Avoid dropping counterweights during disassembly:

- Do not lift lower tray and side boxes as a unit. Lifting lugs may break.
- Do not lift more than two side boxes at a time. Lifting lugs may break.

18. Disassemble upper counterweights (777 boom butt can be used for this purpose).

- a. Unpin and lift side boxes off lower tray — lift at connecting pins (Figure 4-8, View A-A).
- b. Lift side boxes onto trailer.
- c. Lift counterweight tray onto trailer — lift at four lifting lugs (Figure 4-8, View A or B).

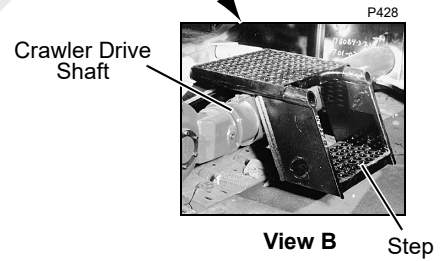
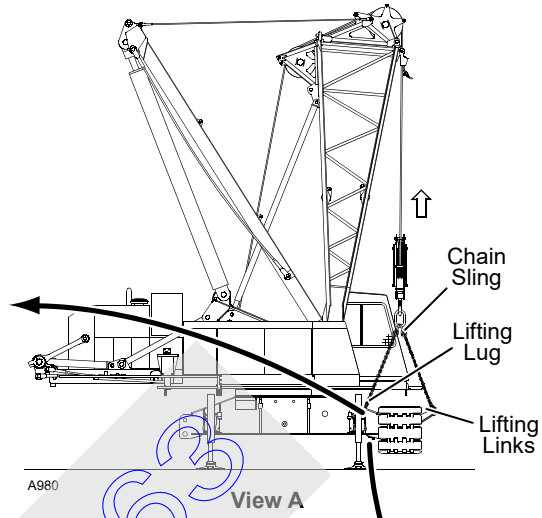
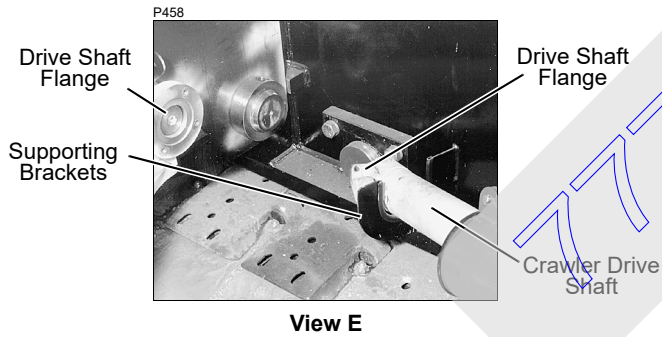
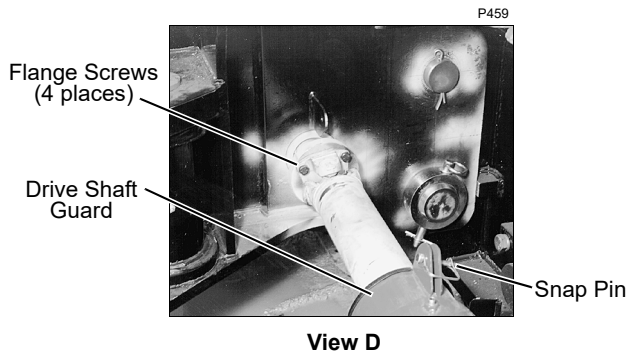
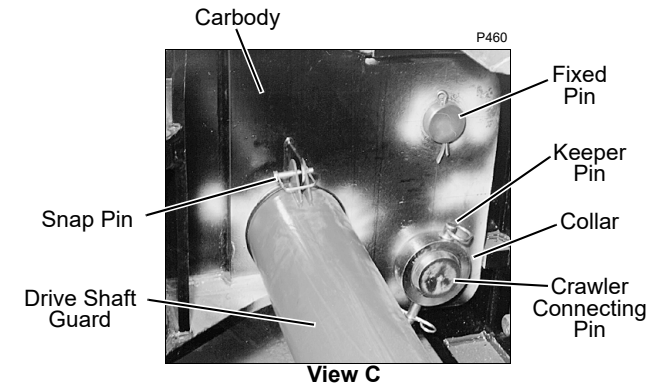

! DANGER
Tipping Hazard!

Do not exceed 15 feet (4.6 m) radius while lifting either crawler. Crane will tip.

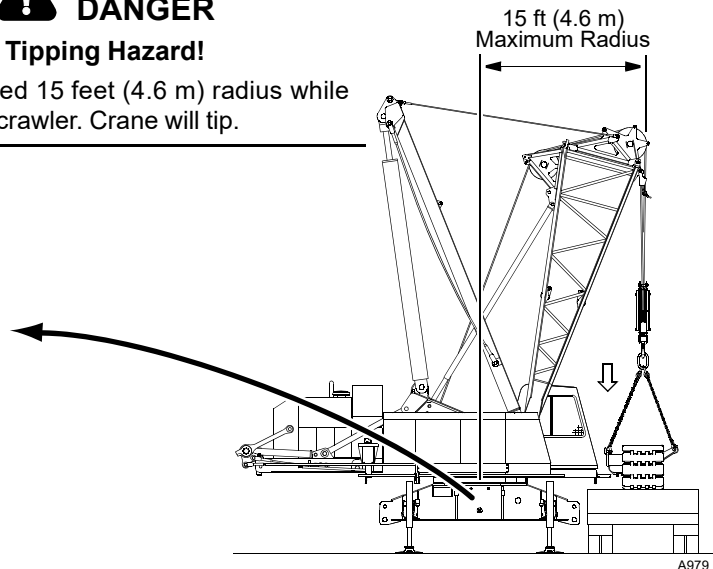
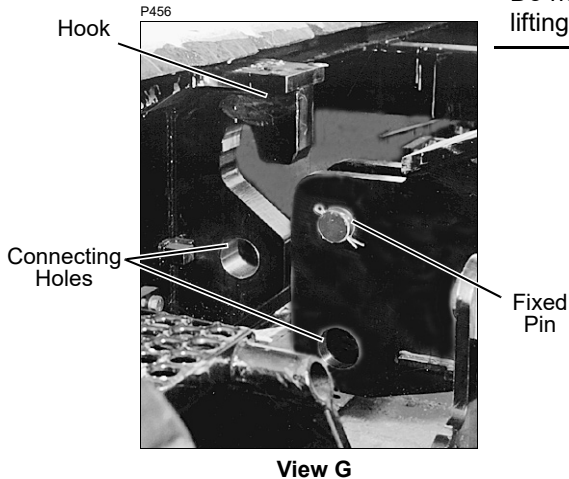

View F

FIGURE 4-18

Remove Crawlers

See Figure 4-18 for this procedure unless otherwise noted.

DANGER Tipping Hazard!

Prevent crane from tipping over:

- Make sure crane is level. Check 2-way level on front of carbody. Adjust jacks as required.
- Do not exceed 15 ft (4.6 m) radius while lifting either crawler.

CAUTION Parts Damage!

Avoid hitting carbody jacks with crawlers.

1. If required for transport, remove steps from both crawlers (View B).

DANGER Rotating Drive Shaft Hazard

Crawler drive shafts rotate at high speed. To prevent death or serious injury:

- Do not attempt to disconnect drive shafts until crane has been parked and engine stopped.
2. Perform following steps at both drive shafts:
 - a. Unpin drive shaft guard (View C) and slide guard back.
 - b. Remove flange screws from drive shaft flange (View D).
 - c. Retract crawler drive shaft and place drive shaft on supporting bracket (View E).
 - d. Remove keeper pins and collars from crawler connecting pins (View C). Use handle on front of carbody to retract pins.
 3. Position each carbody jack as follows:
 - a. Remove connecting pin 1 (Figure 4-5, View A).
 - b. Rotate jack out and install connecting pin 1 (Figure 4-5, View B).
 - c. Remove connecting pin 2 (Figure 4-5, View A).
 - d. Rotate jack down and install connecting pin 2 (Figure 4-5, View B).
 4. Remove jack pads from storage position (Figure 4-5, View C) and connect jack pad to each jack rod with U-shaped pin (Figure 4-5, View B).

5. Using controls on front of carbody (Figure 4-5, View A), extend carbody jacks until crawler treads are just clear of ground.

WARNING Moving Part Hazard!

Avoid serious crushing injury:

- Warn all personnel to stand clear of jacks.

Tipping Hazard!

Avoid tipping crane over:

- Keep crane level while jacking.

NOTE: A 2-way level is provided near controls on front of carbody (Figure 4-5, View D).

6. Attach three hooks from chain sling to lifting lug on inboard side of crawler and lifting links on outboard side of crawler (View A).

Position boom and rotating bed so assembly block is centered over crawler. Crawler can bind on carbody if crawler is not hoisted vertically.

7. Slowly hoist crawler to disengage hooks on crawler from fixed pins on carbody wings (View G).

DANGER Tipping Hazard!

Do not allow assembly block to swing past inside edges of carbody jacks (Figure 4-19) while removing first crawler. Crane will tip.

8. Lift crawler onto trailer (View F).
9. Engage crawler connecting pins and install collars and keeper pins (View C).
10. Unhook chain sling from crawler.
11. Swing over other side.
12. Repeat steps 6 through 10 for other crawler.

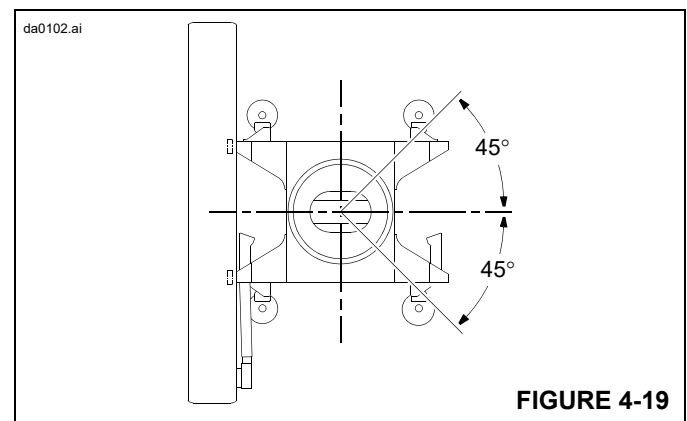

FIGURE 4-19

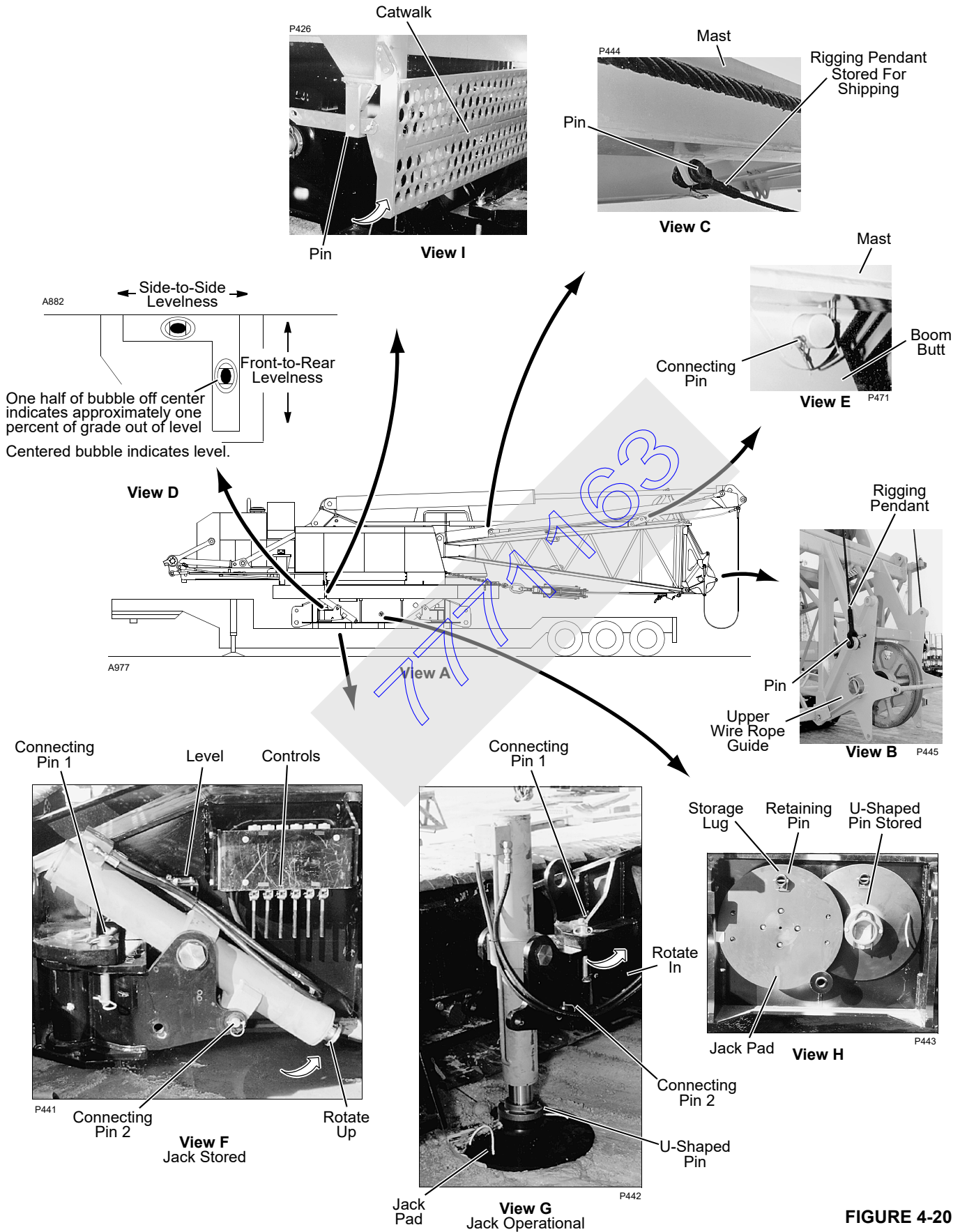

FIGURE 4-20

Install Crane on Trailer

See Figure 4-20 for following procedure.

Operating Note

360° swing is permitted when crane is on jacks with boom butt in transport position.

1. Position trailer under crane. Fully extend carbody jacks if required.



WARNING Moving Part Hazard!

Avoid serious crushing injury:

- Warn all personnel to stand clear of crane and trailer.

Tipping Hazard!

Avoid tipping crane over:

- Do not hit carbody jacks with trailer.

2. Block between carbody and trailer as required.
3. Using controls on front of carbody (View F), retract carbody jacks fully to lower crane onto trailer.

NOTE: A 2-way level is provided near controls on front of carbody (Views D and F).

4. Connect chain sling from assembly block to a shackle attached to lug on front of rotating bed.
5. Lower boom butt onto trailer.
6. Disconnect rigging pendants from upper wire rope guide on front of boom butt (View B) and connect pendants to storage position on mast (View C).
7. Connect mast to boom butt with mast-to-butt connecting pins (stored in lugs on mast) (View E).
8. Boom up to raise boom butt 12 – 18 in. (0.3 – 0.5 m) off trailer.

CAUTION

Boom Stop Interference!

Booming above 10° with mast-to-butt connecting pins installed will cause damage to mast cross member.

Boom Damage!

Do not block between boom butt and trailer or between mast and boom hoist cylinders. Stresses induced during transport can result in damage to boom butt and cylinders if this precaution is not taken.

9. Securely fasten carbody to trailer. Securely install chains in a crisscross manner between rotating bed and trailer to prevent rotating bed from swinging.
10. Remove jack pads and store (View H).
11. Position each carbody jack as follows:
 - a. Remove connecting pin 2 (View G).
 - b. Rotate jack up and install connecting pin 2 (View F).
 - c. Remove connecting pin 1 (View G).
 - d. Rotate jack in and install connecting pin 1 (View F).
12. Lower and pin all catwalks (View I) in storage position.
13. Stop engine and turn off cab power. *Remove all keys from operator's cab and lock cab door.*

AUXILIARY LOAD DRUM INSTALLATION

NOTE: The following instructions apply to the optional auxiliary load drum in the boom butt.

Crane Requirements

The auxiliary load drum can be installed only on cranes that have been modified and are equipped as indicated below. Contact the factory Service Department to determine whether your crane meets these requirements.

Modifications

- Hydraulic and electric components on crane.
- Control handle and programmable controller in operator's cab.
- Boom butt (drum mounting lugs and removable lacings).

Equipment Required

- 10 ft (3.05 m) special insert mounted next to boom butt.

Drum Installation

See Figure 4-21 for following procedure.

It is assumed that the hydraulic hoses and electric cable are connected to the auxiliary load drum (Figure 4-21). If these parts are not installed, see the applicable assembly drawings in your Model 777 Parts Manual for details.

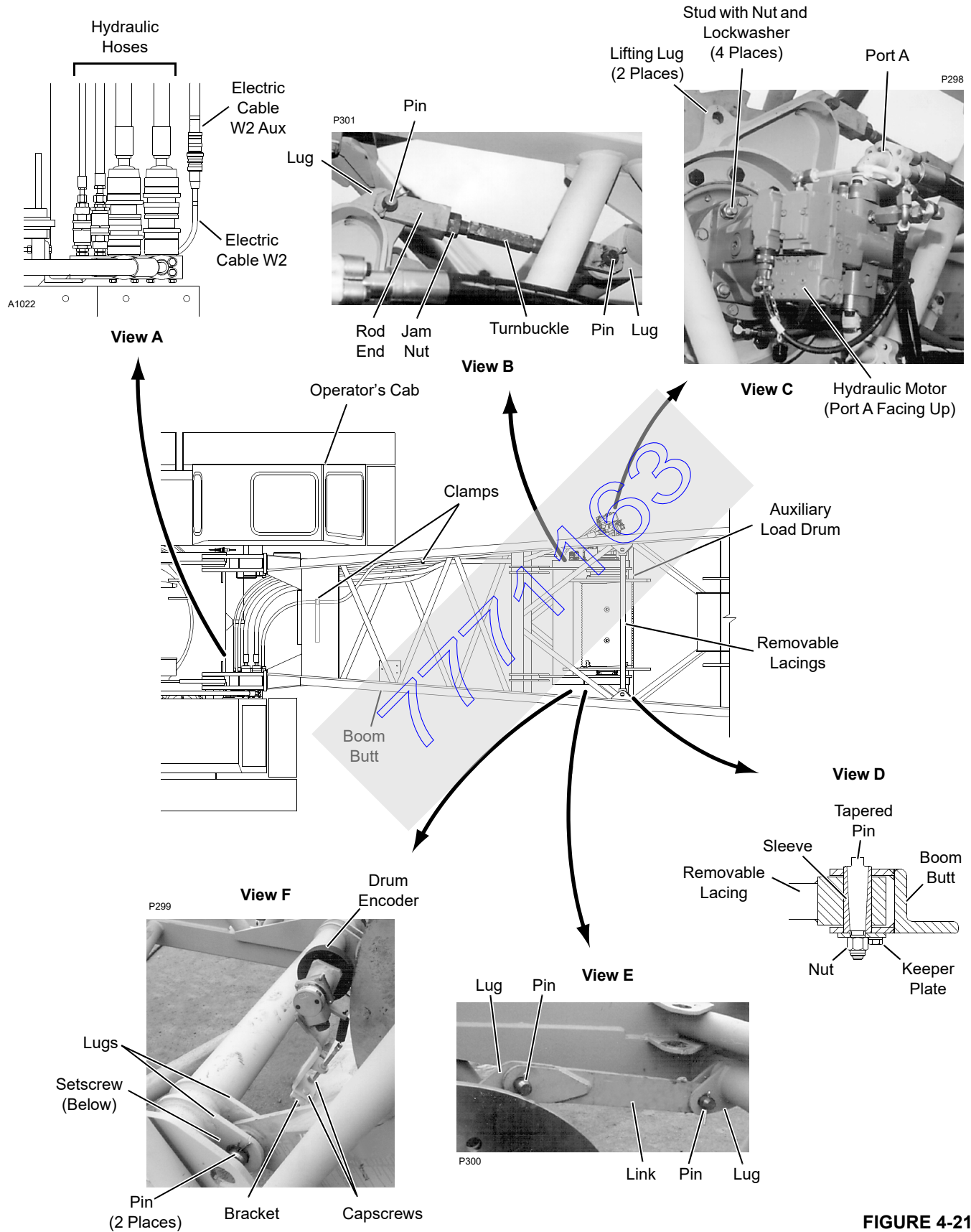

FIGURE 4-21

1. Remove lacing pinned to top chords of butt (View D), as follows:
 - a. Support lacing so it cannot fall.
 - b. Remove keeper plates.
 - c. Remove nuts from tapered pins.
 - d. Carefully tap tapered pins up and out of tapered sleeves. *Be extremely careful to avoid damaging threads on pins.*
 - e. Remove tapered sleeves and remove lacing.

CAUTION!
Parts Damage!

Hydraulic motor and drum encoder can be damaged during drum installation. Remove both from drum assembly before lifting drum into place.

2. Support hydraulic motor with assist crane. The motor weighs approximately 150 lb (68 kg).
 3. Remove hydraulic motor from studs on auxiliary load drum (View C). *Store motor in a clean, protected area free of dirt.*
 4. Remove drum encoder from support on auxiliary load drum (View F). *Store encoder in a clean, protected area free of dirt.*
 5. Hook assist crane to lifting lugs on auxiliary load drum (View C). The auxiliary drum weighs approximately 2,750 lb (1 247 kg).
 6. Using assist crane, lift auxiliary load drum above boom butt, and lower it through opening. Motor side of drum must be on left side of butt.
11. Pin turnbuckle rod ends to lugs on left side of boom butt and auxiliary load drum (View B).
Adjust turnbuckle as required so holes in rod ends line up with holes in lugs. Securely tighten jam nuts.
Install cotter pins.
 12. Install hydraulic motor, as follows:
 - a. Be sure that O-ring is in place on hydraulic motor.
 - b. Lift motor into position with assist crane.
 - c. Slide hydraulic motor onto studs (View C) so motor is positioned as shown with Port A facing UP.
 - d. Install lockwashers and nuts. Torque nuts to 180 ft lb (244 N-m).
 13. Install removable lacing, as follows (View D):
 - a. Slide ends of lacing into lugs on boom butt and align holes.
 - b. Install tapered sleeves. Hole in sleeves must taper down.
 - c. Install tapered pins.
 - d. Carefully tap tapered pins down into sleeves and install nuts.
 - e. Alternate tapping pins down and tightening nuts until lacing is securely fastened.
 - f. Install keeper plates.
 14. Attach drum encoder to bracket on drum frame (View F).

CAUTION!
Parts Damage!

While lowering drum, be careful that drum does not bump or damage chords or adjacent lacings.

7. Pin auxiliary load drum to lugs on each side of boom butt (View F). Insert cotter pins.
8. Shift drum assembly as far to left as possible with assist crane.
9. Remove side play by tightening setscrew to jack drum frame to side (View F). Tighten jam nut to lock setscrew in place.
10. Pin link to lugs on right side of boom butt and auxiliary load drum (View E). Install cotter pins.

Hydraulic and Electric Connections

See Figure 4-21 for following procedure.

1. Install clamp assemblies on boom butt (two places) for hydraulic hoses and electric cable.
2. Fasten hydraulic hoses and electric cable to clamps.
3. Connect hydraulic hoses to couplers at right side of boom butt (View A). Size and configuration of couplers make it impossible to hook up hoses incorrectly.
4. Connect electric cable W2AUX to cable W2 at right side of boom butt (View A).

Wire Rope Installation

See Load Line Reeving in this section for wire rope installation procedures.

Butt Removal

If butt is removed with auxiliary load drum installed, hydraulic hoses and electric cable must be disconnected from couplers at right side of boom butt (Figure 4-21, View A).

A1023

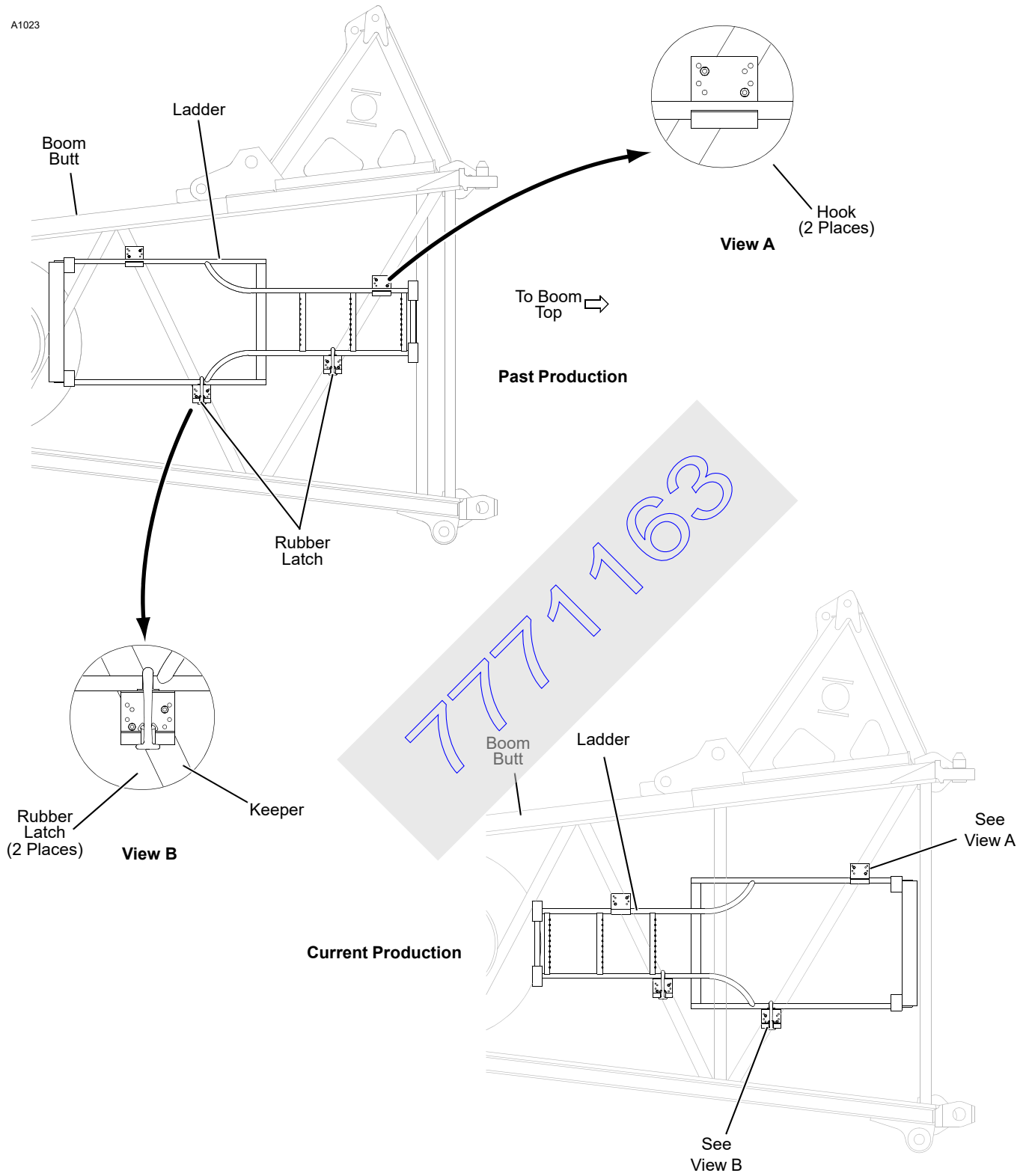

FIGURE 4-22

BOOM LADDER ASSEMBLY



WARNING

To Prevent Serious Injury or Death:

- Limit load on ladder to 300 lb (136 kg).
- Avoid improper use. Use this ladder only on Manitowoc #78 boom inserts. Do not use on any other boom.
- Use ladder for boom assembly, disassembly, and maintenance only when boom is horizontal and securely blocked on ground. Do not use ladder on tapered inserts.
- Make sure ladder is properly secured to insert.
- When climbing ladder, hands shall be free of any objects. Objects which cannot be carried in pockets or tool belts shall be lifted in place on ladder platform prior to climbing ladder.
- Stand on platform only. Do not stand on cross braces.

Two ladders are installed inside the boom butt, one on either side. The ladders are designed for use in assembly, disassembly, and maintenance of #78 boom sections and components. Each ladder weighs approximately 18 lb (8 kg).

Removal From Boom Butt

It is recommended that two people remove ladder from boom butt: one person inside butt to unlatch and lift ladder and another person outside of butt to help guide ladder out of butt. Use the following procedure:

1. Lower boom onto blocking at ground level. *Boom sections must be horizontal.*
2. Unhook rubber latches (Figure 4-22, View B).
3. Lift ladder up and out of hooks (Figure 4-25, View A).
4. Guide ladder through lacings to outside of boom butt.

Installation on Boom Inserts

Lift ladder to desired outside location on insert so that upper pads are securely hooked over backside of upper chord and lower pads rest firmly against lower chord (Figure 4-23).

Ladder must hang vertically against boom insert when in use.

Storage in Boom Butt

It is recommended that two people store ladder in boom butt: one person outside of butt to help guide ladder into butt, and another person inside butt to lift ladder and latch it in position. Use the following procedure:

1. Hang ladder rails over hooks inside butt (Figure 4-22, View A).
2. Pull rubber latches tightly over lower rail and latch in keepers (Figure 4-22, View B).
3. Ensure ladder cannot move once latched in place.



WARNING

Falling Load Hazard!

Ladders must be properly stored to prevent them from falling out of butt when boom is raised.

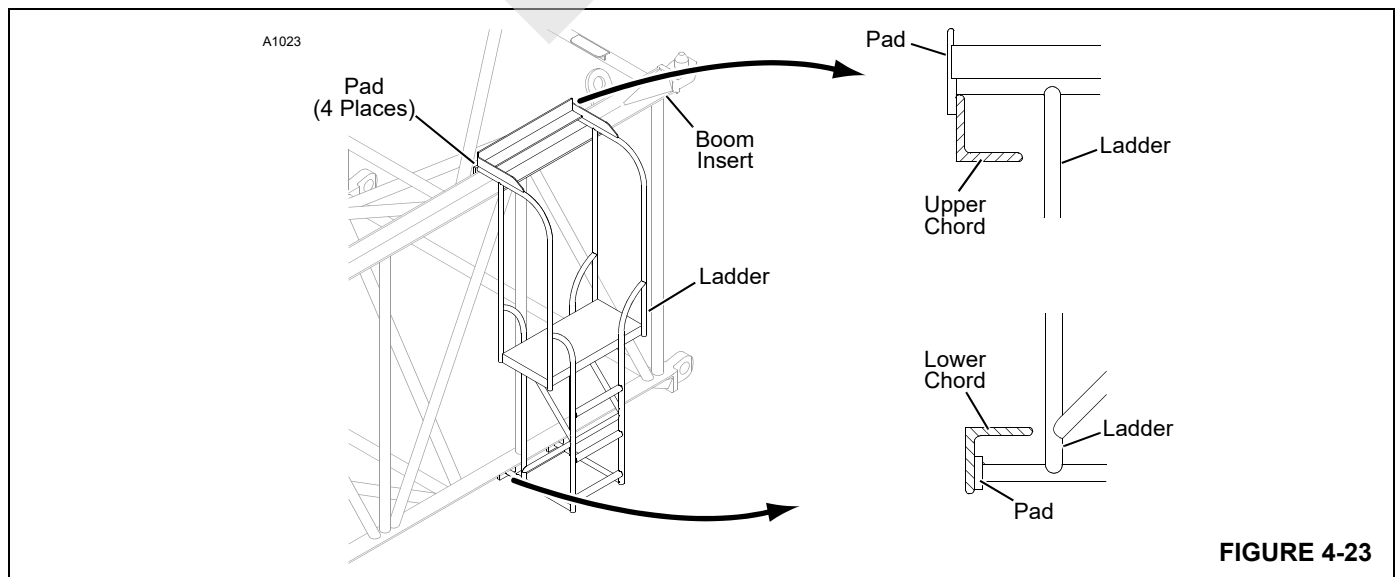

FIGURE 4-23

BOOM RIGGING GUIDE

This topic contains installation and removal instructions for all parts of the boom except the boom butt. Boom butt remains with the crane.

See the Jib Rigging Guide in Section 4 of this manual for jib installation and removal instructions.

Assist Crane Requirements

An assist crane is not required to assemble and disassemble the boom components. The 777 can be used to assemble and disassemble its own boom. See Crane Weights in the Crane Operator Manual for weights of boom components.

The 777 must be in the following configuration to assemble its own boom and jib:

- Crane rigged as shown in Figure 4-24.
- Radius limited to 26 ft (7.9 m).
- Capacity limited to 40,000 lb (18 144 kg) to include 2-part load line, load block, and lifting slings.



WARNING

Falling Load Hazard!

Prevent crane from tipping or structural damage to components:

- Do not exceed 26 ft (7.9) radius.
- Do not lift more than 40,000 lb (18 144 kg).

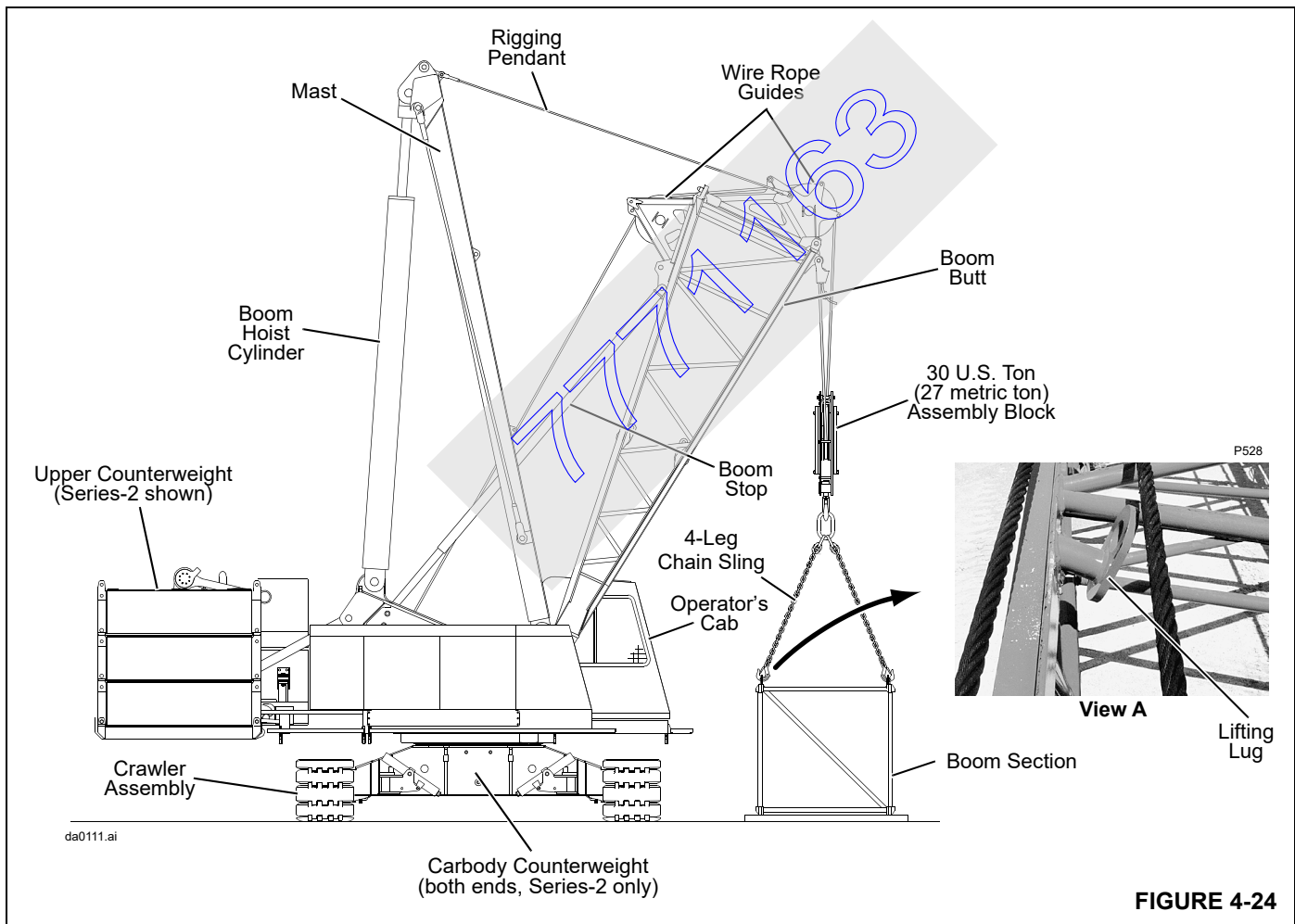

THIS PAGE INTENTIONALLY LEFT BLANK

777163

MAST PINNED TO BOOM BUTT FOR LOW CLEARANCE TRAVEL

Length	10 ft (3.1 m) Insert	20 ft (6.1 m) Insert	40 ft (12.2 m) Insert	37.5 ft (11.4 m) Top
37.5 ft (11.4 m) No Block	0	0	0	1
90 ft (27.4 m)	1	2	1	0
	1	0	2	0

CAUTION

Boom Stop Interference!

Booming above 10° with mast pinned to butt will cause damage to mast cross member.

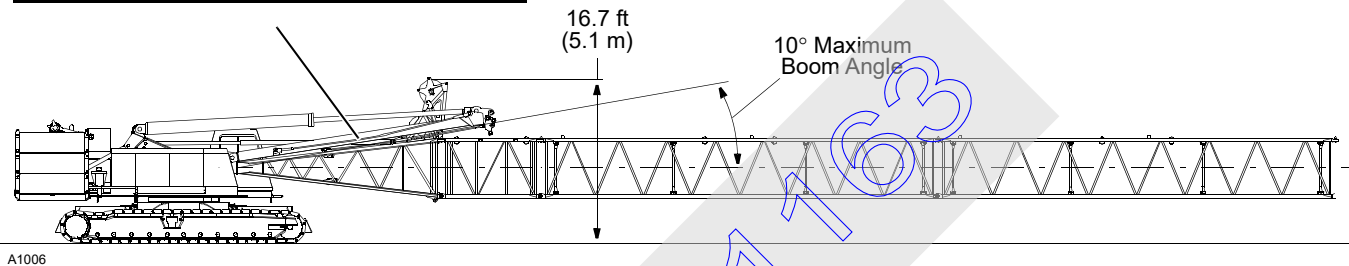

A1006

BOOM HANDLING WITH MAST
With Mast Rigging Pendants Pinned to Rope Guide

Length	10 ft (3.1 m) Insert	20 ft (6.1 m) Insert	40 ft (12.2 m) Insert
40 ft (12.2 m)	2	1	0
50 ft (15.2 m)	1	2	0
60 ft (18.3 m)	2	0	1
60 ft (18.3 m)	0	1	1
80 ft (24.4 m)	0	2	1
80 ft (24.4 m)	0	0	2

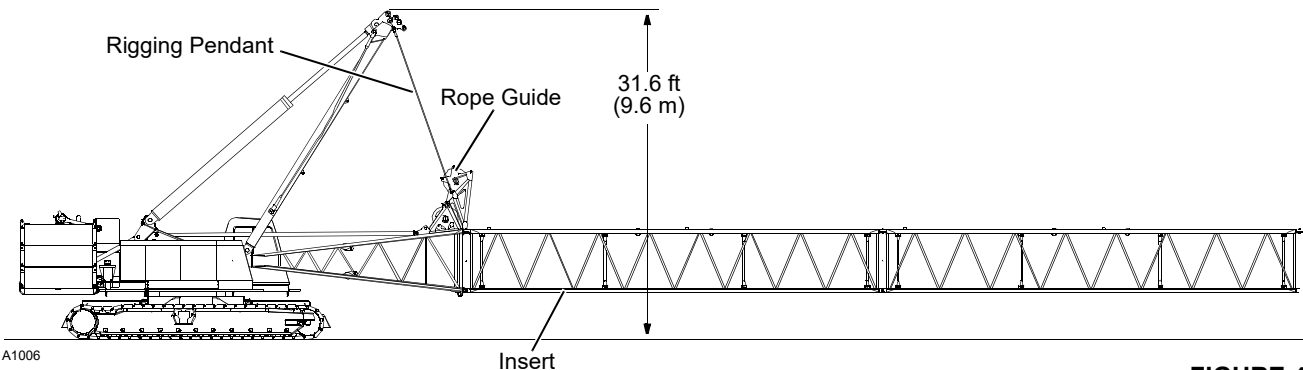

A1006

FIGURE 4-25

Blocked Crawlers

To prevent the crane from tipping, some boom and jib lengths must be raised and lowered over blocked crawlers. See capacity charts for blocked crawler requirements and to Crawler Blocking Diagram in Capacity Chart Manual for instructions.

! DANGER
Tipping Hazard!

Do not attempt to raise or lower boom and jib from or to ground until crawlers are blocked, if required. Otherwise, crane will tip.

Handling Components

Handle boom sections with care. Four lifting lugs are provided on each section for handling with hooks, chain sling, or slings (Figure 4-24).

If lugs are not used, nylon slings should be used to handle boom sections. If wire rope or chain slings are used, protective covering (such as sections of rubber tire) must be used between the slings and the section. *Lift against chords only, never against lacings.*

Boom handling for low clearance travel is limited. See the chart in Figure 4-25.

! WARNING
Falling Boom Hazard!

Do not attempt to handle more boom than shown in Figure 4-25. Structural failure of wire rope guide could result, possibly allowing boom to fall.

! WARNING

Boom can only be picked up at butt. Structural failure of wire rope guide could result if boom is picked anywhere other than at butt.

Boom Rigging Assembly Drawing

Boom components (top, inserts, butt, pendants) must be assembled in the proper sequence according to this topic

and the Boom Rigging Assembly drawing at the end of the manual. See Figure 4-31 to determine the quantity and length of inserts and pendants for various boom lengths.

When disassembling the boom, the pendants can be disconnected and left on top of the inserts for shipping. This arrangement allows the boom to be reassembled faster.

It is owner/user's responsibility to securely attach pendants to inserts so that pendants cannot fall off inserts during shipment.

Identifying Boom Sections And Pendants

Boom sections are marked for proper identification as shown in Figure 4-26, View A — Boom number, part number, and manufacturing code are stamped into a plate mounted on all four chords of each section.

Pendants are marked for proper identification as shown in Figure 4-26, View B.

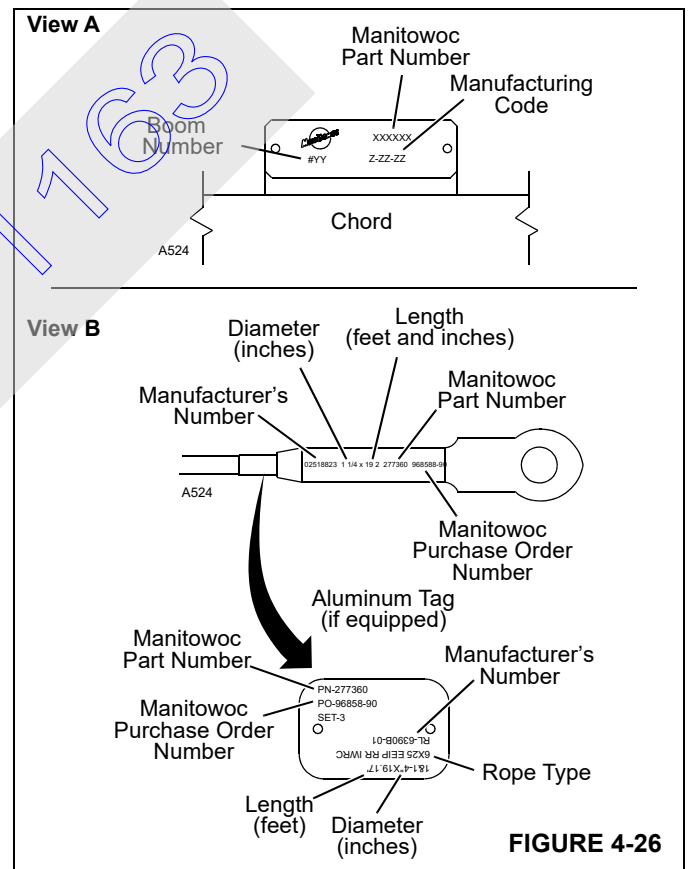

FIGURE 4-26

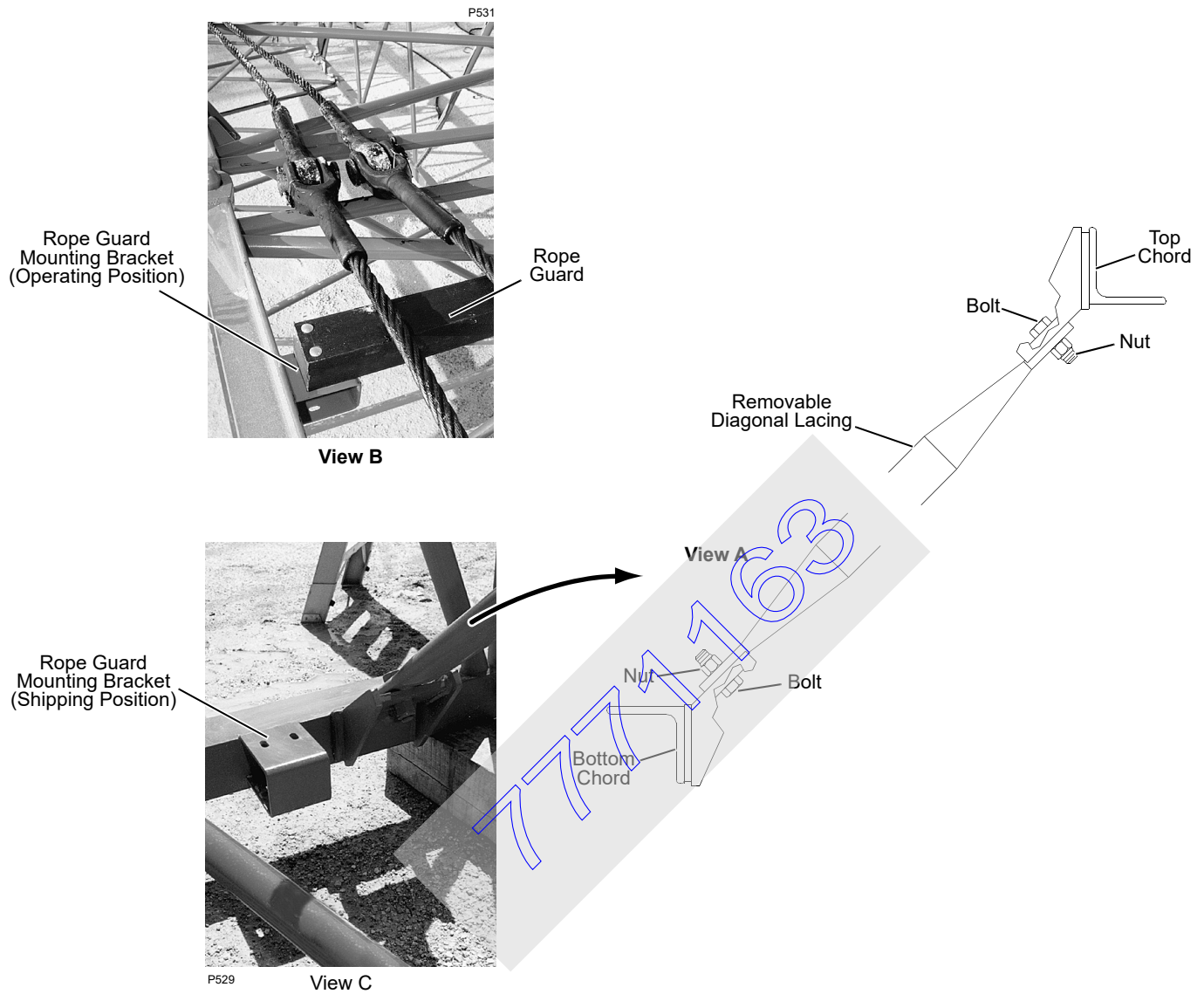

FIGURE 4-27

Removable Lacings

Removable diagonal lacings are provided with the #78 boom. This design feature allows the lacings to be removed so that fixed and luffing jib sections can be stored inside the inserts, thereby reducing shipping space and the number of shipping vehicles required.

Table 4-2
Lacing and Rope Guard Requirements

# 78 Insert	Number of Diagonal Lacings Required	Number of Rope Guards Provided
20 ft (6.1 m)	2	1
40 ft (12.2 m)	4	2

* Remove required number of guards from operating position and fasten in shipping position.

Storing Jib Sections

See Figure 4-27 for following procedure.

To store jib sections inside # 78 inserts, proceed as follows.

1. Remove diagonal lacings from inserts (View A).
2. Remove rope guards from operating position on top chords of inserts.
3. Fasten required number of rope guards to bottom chords of inserts.
To prevent damage to rope guards, do not exceed 1,500 lb (680 kg) load on each rope guard.
4. Install jib sections inside inserts. *Take extreme care not to damage lacings or chords.*
5. Adjust position of jib sections so that diagonal lacings can be reinstalled.
6. Reinstall proper number of diagonal lacings with bolts and nuts provided (View A). See Table 4-2 for lacing requirements.
7. Securely attach jib sections to inserts so jib sections cannot shift during transport.

Fasten tie-downs to rope guards or chords of inserts only, not to lacings. Take care not to bend rope guards

when tightening tie-downs. Use protective covering such as tire sections between tie-downs and chords or rope guards.

Removing Jib Sections

See Figure 4-27 for following procedure.

To remove jib sections from inside the # 78 inserts proceed as follow:

1. Remove diagonal lacings from inserts (View A).
2. Carefully remove jib sections from inside inserts. *Take extreme care not to damage lacings or chords.*
3. Remove rope guards from bottom chords inside inserts.
4. Fasten rope guards in operating position on top chords of inserts. See Table 4-2 for rope guards requirements.



WARNING

Tipping Crane Hazard!

Remove rope guards from bottom chords inside inserts before attempting to raise boom. Added weight of rope guards inside inserts may cause crane to tip when boom is raised.

5. Thoroughly clean all dirt from between lacings and mating mounting surfaces on inserts.
6. Reinstall proper number of diagonal lacings in inserts with bolts and nuts provided (View A). See Table 4-2 for lacing requirements.
7. Securely tighten nuts.



WARNING

Falling Boom Hazard!

Securely reinstall diagonal lacings before attempting to raise boom. Boom may collapse if lacings are not reinstalled.

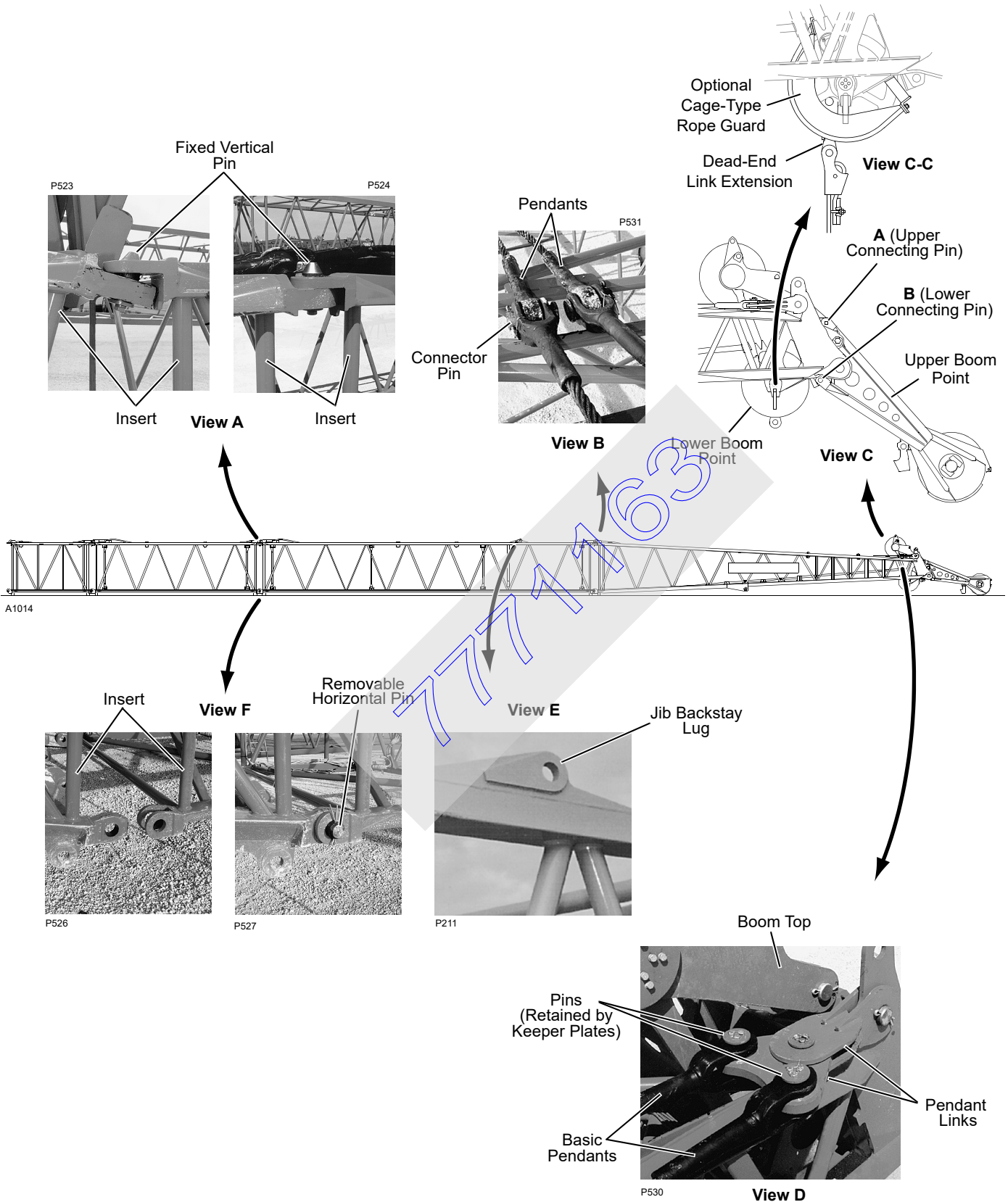

FIGURE 4-28

Boom Installation



WARNING

Collapsing Boom Hazard!

To prevent death or serious injury, do not stand on, inside, or under boom sections during assembly. Always stand outside of boom sections when installing connecting pins.

Assemble Boom

The boom sections have FACT™ connectors:

- The top connectors are joined by fixed vertical pins that hook into holes in the adjacent section (Figure 4-28, View A).
- The bottom connectors are joined by removable horizontal pins (Figure 4-28, View F).

Assemble the inserts, starting with the inserts closest to the boom butt and moving out toward the boom top.

1. If not already done, install rope guards on top of boom sections as shown in Figure 4-27, View B. See Table 4-2

for number of rope guards required on each insert. Additionally, two rope guards are required on boom top.

2. Assemble boom inserts in proper sequence (Figure 4-31), as follows, starting at butt end of boom:
 - a. Place first insert on blocking approximately 6 in. (152 mm) high.
 - b. Lift next insert into position and engage top connector holes with fixed vertical pins as shown in Figure 4-28, View A.
 - c. Lower insert until bottom connector holes are aligned and install removable horizontal pins as shown in Figure 4-28, View F.
 - d. Block under bottom chords at top end of insert.
 - e. Repeat steps 2a – 2d until all inserts and boom top have been installed.
3. Intermediate suspension is required for boom lengths of 190 – 270 ft (57.9 – 82.3 m).

If intermediate suspension is required for your boom length, install it now.

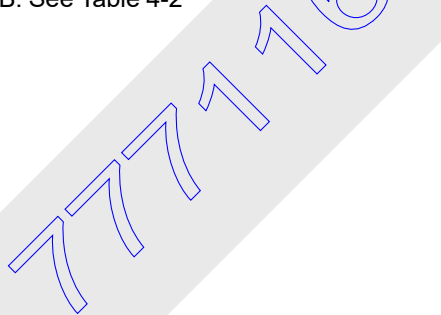

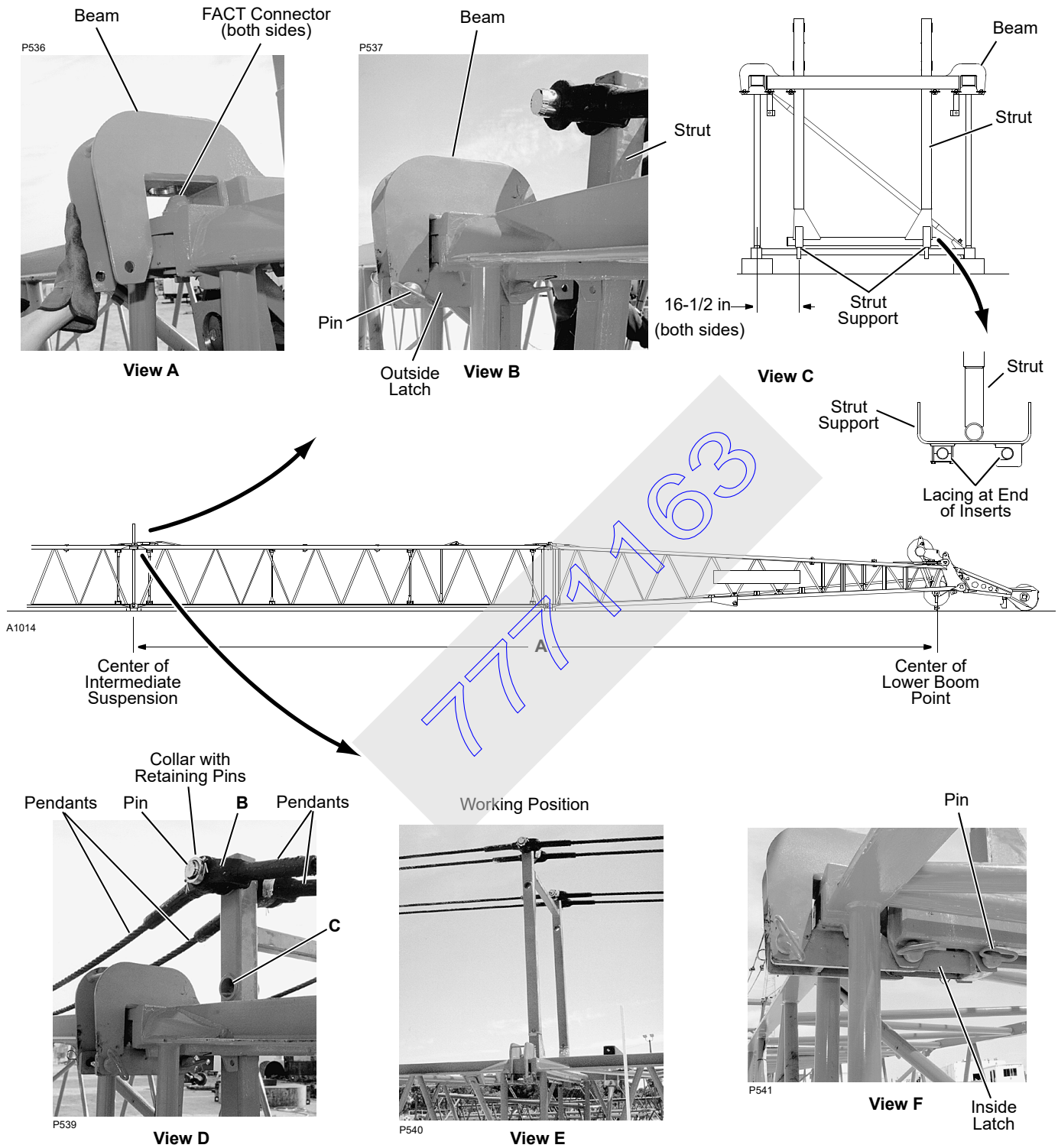

FIGURE 4-29

Install Intermediate Suspension

See Figure 4-29 for following procedure.

Intermediate suspension is required for booms 190 – 270 ft (57.9 – 82.3 m) in length. See Table 4-3 for intermediate suspension strut and pendant positions.

If intermediate suspension is necessary, install the suspension strut and connect the pendants to the strut before connecting the boom to the boom butt.

Table 4-3
Intermediate Suspension Requirements

Boom Length	Assembly Location A (Figure 4-29)	Pendant Position on Strut
190 ft (57.9 m)	77.5 ft (23.6 m)	C
200 ft (61.0 m)	77.5 ft (23.6 m)	C
210 ft (64.0 m)	117.5 ft (35.8 m)	B
220 ft (67.1 m)	117.5 ft (35.8 m)	B
230 ft (70.1 m)	117.5 ft (35.8 m)	B
240 ft (73.2 m)	117.5 ft (35.8 m)	C
250 ft (76.2 m)	117.5 ft (35.8 m)	C
260 ft (79.2 m)	117.5 ft (35.8 m)	C
270 ft (82.3 m)	137.5 ft (41.9 m)	B

1. Determine correct positioning of intermediate suspension on boom insert. See Table 4-3 and Figure 4-29 for positioning.
2. Install strut supports between bottom laces of two inserts at point where intermediate suspension will be installed (View C).
3. Remove pins connecting four latches to suspension beam (Views B and F).
4. Lift intermediate suspension into position over FACT connectors between required boom insert (View A).
5. Engage outside latches on suspension beam and pin latches in position (View B).
6. Lower strut onto strut supports (View C).

Install Pendants



WARNING **Falling Boom Hazard!**

Starting at butt end of boom, pendants must be installed in same sequence as inserts (shortest inserts and pendants nearest butt).

Pendants are furnished in matched sets of four and must be installed in matched sets — two pendants on one side of insert must match two pendants on opposite side of insert.

Failing to comply with these precautions can result in severe side loading of boom and mast. Structural damage to boom and mast could occur, possibly causing boom to collapse.

1. Pin basic pendants to pendant links (Figure 4-28, View D).
2. Stretch basic pendants tightly along top of boom.
3. Pin remaining pendants in proper sequence to basic pendants (Figure 4-28, View B and Figure 4-31). *Install pendant connecting pins so heads face each other.*
4. Stretch pendants tightly along top of boom as assembly progresses. *Make sure pendants are not crossed.*
5. If equipped with intermediate suspension, attach pendants at holes in position B or C on strut (see Table 4-3 and Figure 4-29, View D):
 - a. Align pendants on either side of proper hole in strut.
 - b. Install connecting pin through pendant connectors and hole in strut.
 - c. Install collars and retaining pins on both ends of connecting pin.
6. *Make sure pendants are not hooked under lifting lugs* (Figure 4-24, View A).

Install Upper Boom Point

If required, install upper boom point as follows:

1. Lift upper boom point into position at end of boom top (Figure 4-28).
2. Align upper connecting holes at A and install connecting pins and snap pins. Do not pin lower holes. This will allow upper boom point to rest on blocking (Figure 4-28, View C).
3. Install lower connecting pins and snap pins at holes B after upper boom point is clear of ground (Figure 4-28, View C).

Install Jib

See Jib Rigging Guide in this section for jib installation instructions. Upper boom point must be removed prior to jib installation.

Connect Boom Butt to Boom

See procedure earlier in this section.

Install Load Line

See Load Line Reeving in this section for proper routing and reeving of load lines.

Manitowoc recommends installation of the cage-type rope guard (Figure 4-28, View C-C) for all duty-cycle operations (clam, drag, pile driving). The rope guard will protect the sheaves from side-load damage.

On current production jibs, remove the rope guards (Figure 4-30) to pull the load line through the jib point and strut without removing the socket and wedge.

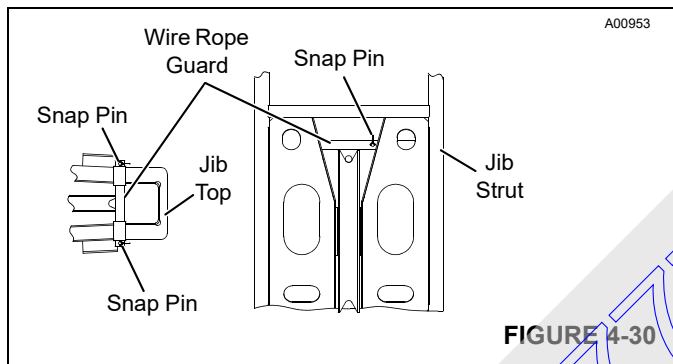

Install Block-Up Limit Control

Install block-up limit components and connect electrical cords as shown in Block-Up Limit Control Assembly Drawing at the end of this section.

See Section 5 of the Crane Service Manual for adjustment of the limit switches.

Install Rated Capacity Indicator/Limiter Components

Install rated capacity indicator/limiter components and connect electrical cords as shown in Rated Capacity Indicator/Limiter Assembly Drawing at the end of this section for installation.

Install Wind Speed Indicators

Install wind speed indicator components and connect electrical cords as shown in Wind Speed Assembly Drawing at the end of this section.

Perform Pre-raising Checks

Perform the pre-raising checks given earlier in this section.



WARNING

Falling Jib Hazard!

Visually observe that jib stop pins fully engage holes in jib stop frame as boom and jib are raised from ground.

Jib can be pulled over backwards if jib stop pins do not engage.

Boom Removal

Store Load Lines

Disconnect load lines from load block and from hook-and-weight balls.

Spool load lines onto load drums for storage.

Remove Electrical Components from Boom and Jib

Disconnect applicable electrical cables and remove electrical components from boom and jib:

- Block-up limit components (see Block-Up Limit Control Assembly Drawing at end of this section).
- Rated capacity indicator/limiter components (see Rated Capacity Indicator/Limiter Assembly Drawing at end of this section for installation).
- Wind speed indicator components (see Wind Speed Assembly Drawing at end of this section).

Disconnect Boom Butt from Boom

See procedure earlier in this section.

Install Assembly Block

See procedure earlier in this section.

The 777 can be used to disassemble the boom and jib.

Remove Jib

See Jib Rigging Guide in this section for jib removal instructions.

Remove Upper Boom Point

1. Remove upper connecting pins and snap pins at holes A (Figure 4-28, View C).
2. Remove upper boom point from end of boom top.

Disconnect Pendants

Disconnect boom pendants from each other (Figure 4-28, View B) and, if equipped, from intermediate suspension strut (Figure 4-29, View D). Lay pendants on top of boom.

NOTE: When disassembling the boom, the pendants can be left on top of the inserts for shipping. This

arrangement allows the boom to be reassembled faster.

It is owner/user's responsibility to securely attach pendants to inserts so that pendants cannot fall off inserts during shipment.

Remove Intermediate Suspension

1. Using assist crane, lift strut until it is fully extended (Figure 4-29, View E).
2. Remove pins and disengage outside latches on suspension beam (Figure 4-29, View B).
3. Remove intermediate suspension from boom.
4. Remove strut supports (Figure 4-29, View C).

Disassemble Boom

WARNING

Collapsing Boom Hazard!

To prevent death or serious injury, do not stand on, inside, or under boom sections during assembly. Always stand outside of boom sections when installing connecting pins.

1. Place blocking approximately 6 in. (152 mm) high under insert to be removed.
2. Remove horizontal pins from bottom connector holes in insert (Figure 4-28, View F).
3. Lift insert to disengage top connector holes from fixed vertical pins (Figure 4-28, View A).
4. Remove insert.
5. Repeat steps 1 – 4 until all inserts and boom top are disassembled.

777163

BOOM IDENTIFICATION

Item	Description
1	22 ft 6 in (6.9 m) Butt
2	37 ft 6 in (11.4 m) Top
3 ^{ab}	10 ft (3.1 m) Insert
4 ^{ab}	20 ft (6.1 m) Insert with or without Jib Backstay Lugs ^c
5 ^b	40 ft (12.2 m) Insert with or without Jib Backstay Lugs ^c

PENDANT IDENTIFICATION

Item	Description
6	37 ft (11.3 m) Basic
7	10 ft 1 in (3.1 m) Insert
8	20 ft 1-1/2 in (6.1 m) Insert
9	40 ft 3 in (12.2 m) Insert

- a. Maximum number of 10 ft (3.1 m) inserts (item 3) is two. Maximum number of 20 ft (6.1 m) inserts (item 4) is two. Combination of 10 ft (3.1 m) and 20 ft (6.1 m) inserts (item 3 and 4) must not exceed:
 - Two 10 ft (3.1 m) inserts (item 3) and one 20 ft (6.1 m) insert (item 4) or
 - One 10 ft (3.1 m) insert (item 3) and two 20 ft (6.1 m) inserts (item 4).
- b. Except for 270 ft (82.3 m) boom, shortest inserts must be installed next to butt.
- c. Insert with jib backstay lug must be installed nearest to top, if jib will be used.
- d. Pendants come in matched sets of four (two on each side of boom).

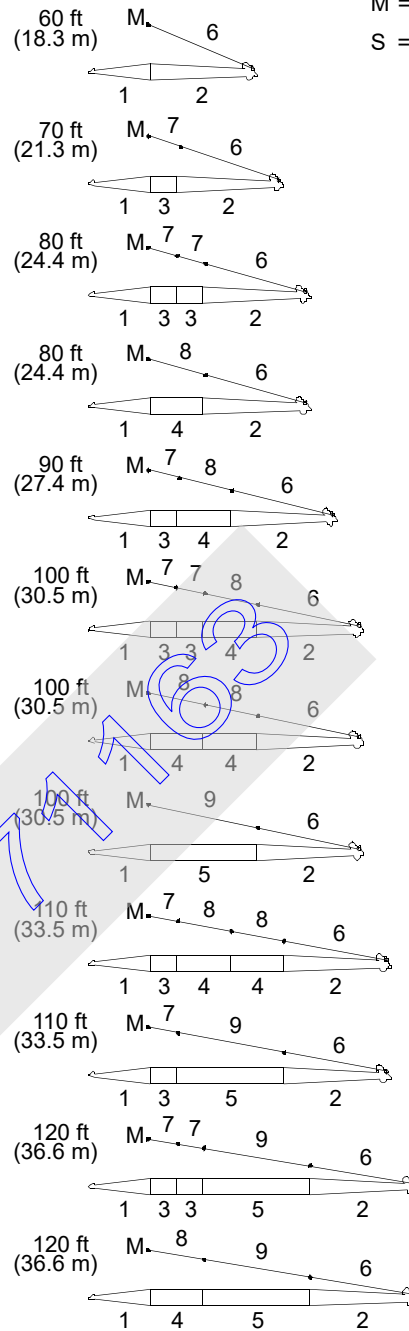

M = Mast Links
 S = Intermediate Suspension (see Table 4-3 and Figure 4-29)

FIGURE 4-31

M = Mast Links
(see Figure 4-12, View G)

S = Intermediate Suspension
(see Table 4-3 and Figure 4-29)

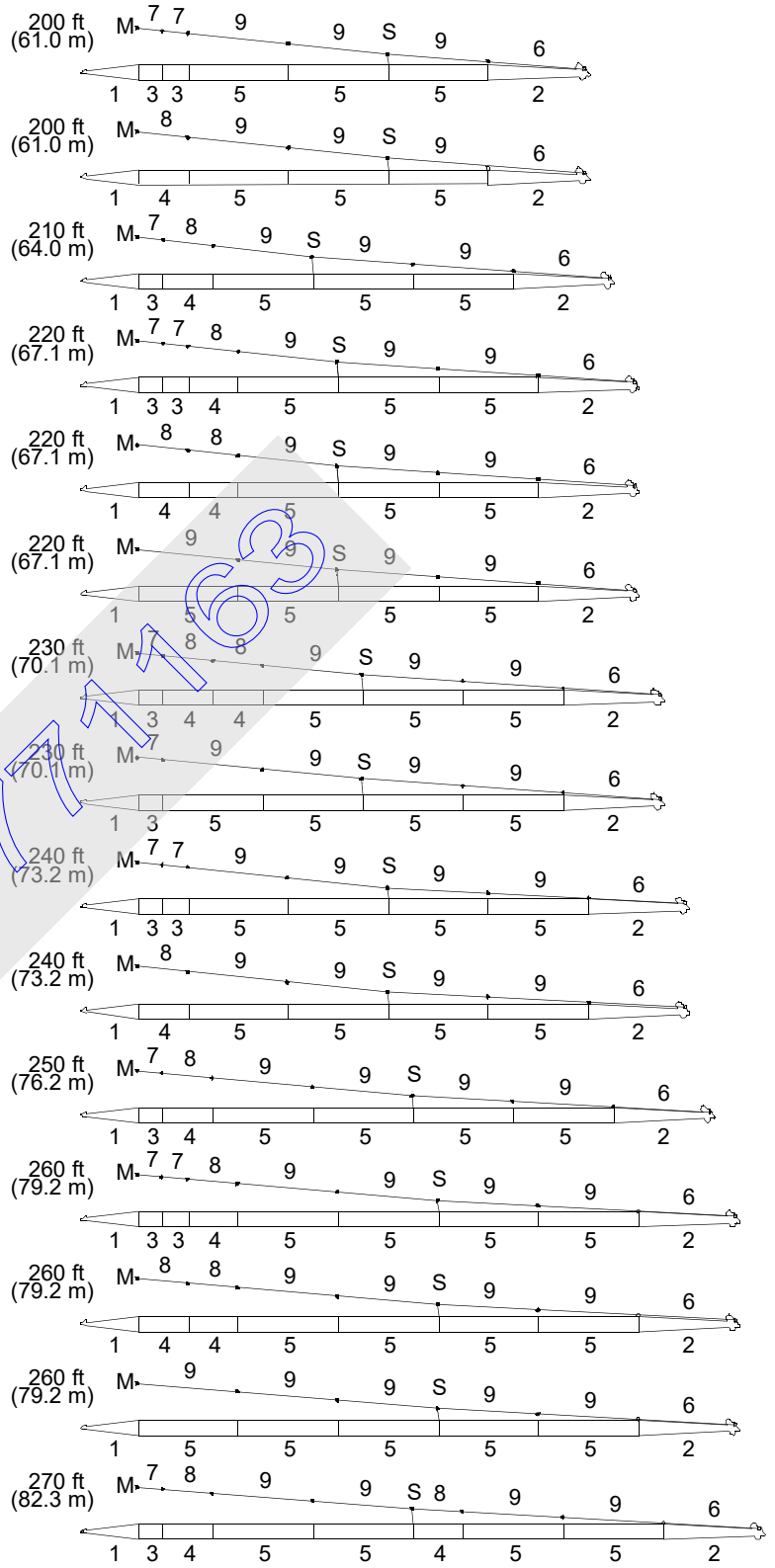
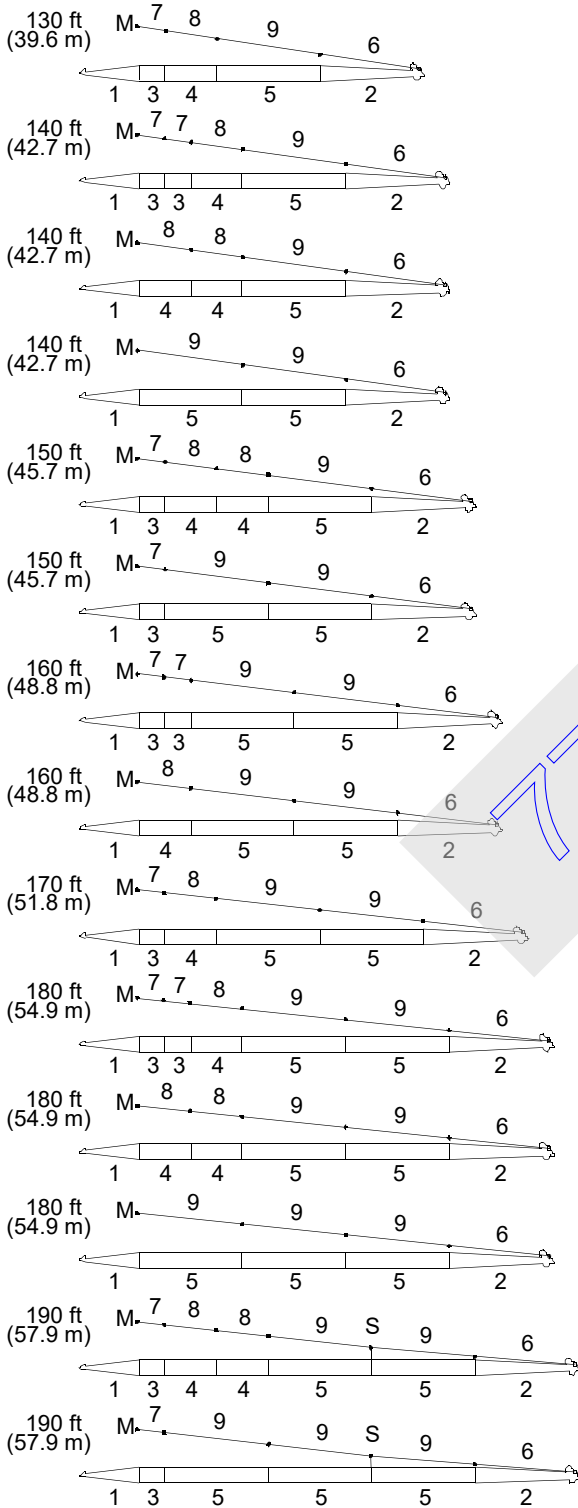

FIGURE 4-31 continued

PILE DRIVER ADAPTER

This topic identifies the pile driver adapter available from Manitowoc for the Model 777.

CAUTION

Pile driver adapter shall be used only with freely suspended loads.

Any side load or torque generated by owner supplied attachments will reduce design loads given in this section. In such cases, contact your Manitowoc dealer for specifications which meet your particular application.

Values given in this publication apply to pile driver adapter only. In all cases, pile drive adapter loads cannot exceed those listed for main boom capacity.

Operating Specifications

With Standard Top

See Figure 4-32 for installation.

- Maximum Boom Length = 140 ft (42.7 m).
- Maximum Load Per Side = Design Load divided by 2.
- Design Loads =

MCC Adapter 179700	MCC Adapter A09693
Made from Mild Steel	Made from T-1 Steel
48,000 lb (21 772 kg) at 55° Boom Angle	48,000 lb (21 772 kg) at 55° Boom Angle
60,000 lb (27 216 kg) at 65° Boom Angle	60,000 lb (27 216 kg) at 65° Boom Angle
	75,000 lb (34 019 kg) at 75° Boom Angle

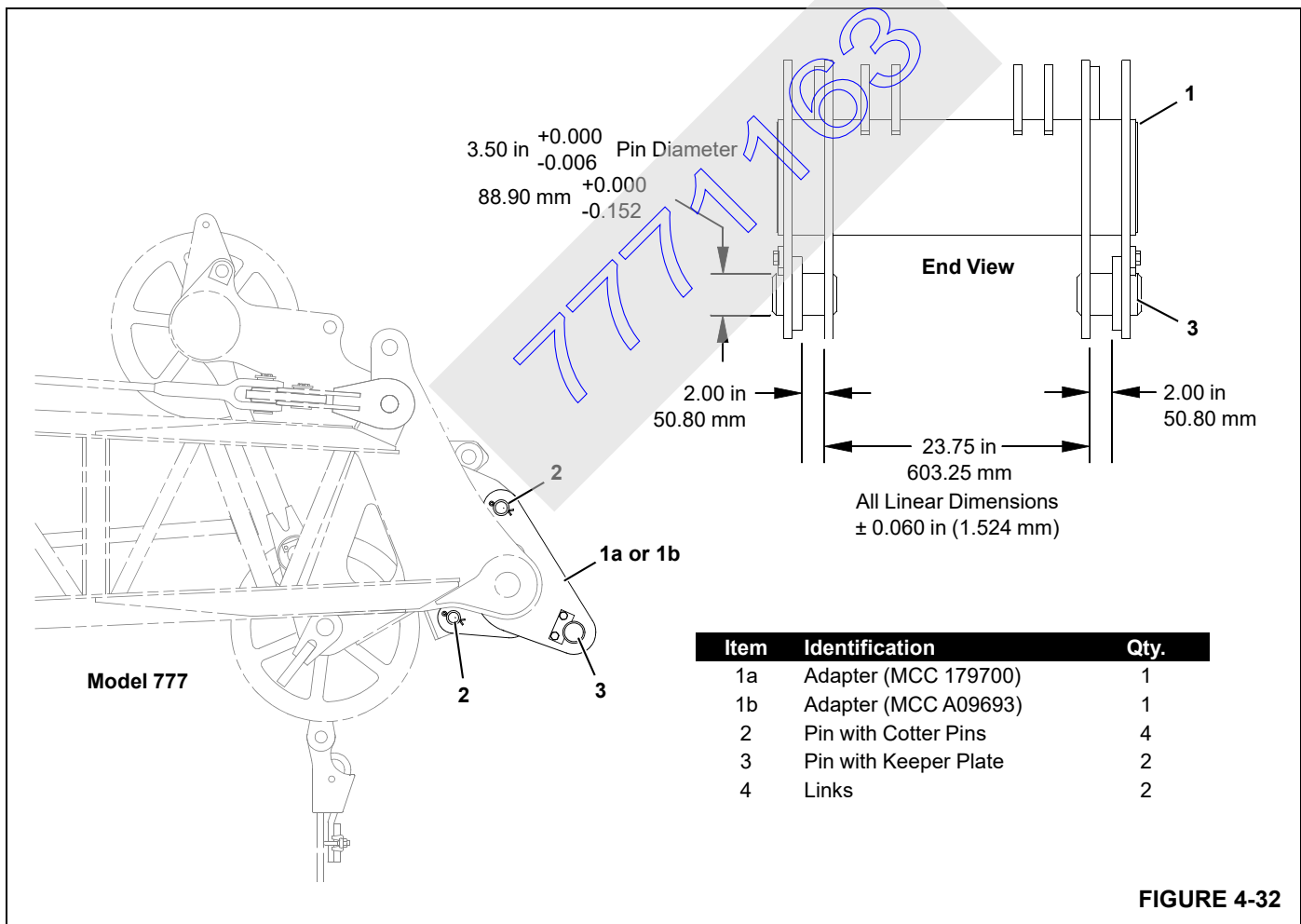

FIGURE 4-32

JIB RIGGING GUIDE

This topic contains installation and removal instructions for the #134 jib on the #78 boom.

The jib consists of a 15 ft (4.6 m) butt and a 15 ft (4.6 m) top, providing a basic length of 30 ft (9.1 m). Inserts are available to make up jib lengths of 40 – 80 ft (12.2 – 24.4 m) as shown in Figure 4-34.

Jib offsets of 5, 15, and 25° are obtained by changing the length of jib backstay straps, links, and pendants as shown in Figure 4-37, View A.

Assist Crane Requirements

An assist crane is not required to assemble and disassemble the jib on a 777 crawler crane. The 777 can be used to assemble and disassemble its own jib.

See the Crane Weights in Section 1 of this manual for weights of jib components.

The 777 must be in the following configuration to assemble its own jib:

- Crane rigged as shown in Figure 4-33.
- Radius limited to 26 ft (7.9 m).
- Capacity limited to 40,000 lb (18 144 kg) to include 2-part load line, load block, and lifting slings.

! WARNING
Falling Load Hazard!

Prevent crane from tipping or structural damage to components:

- Do not exceed 26 ft (7.9) radius.
- Do not lift more than 40,000 lb (18 144 kg).

If rigged with a 5° offset, a fork-lift truck or an assist crane will be required to raise the jib point to provide sufficient pendant slack when connecting the backstay pendants to the boom.

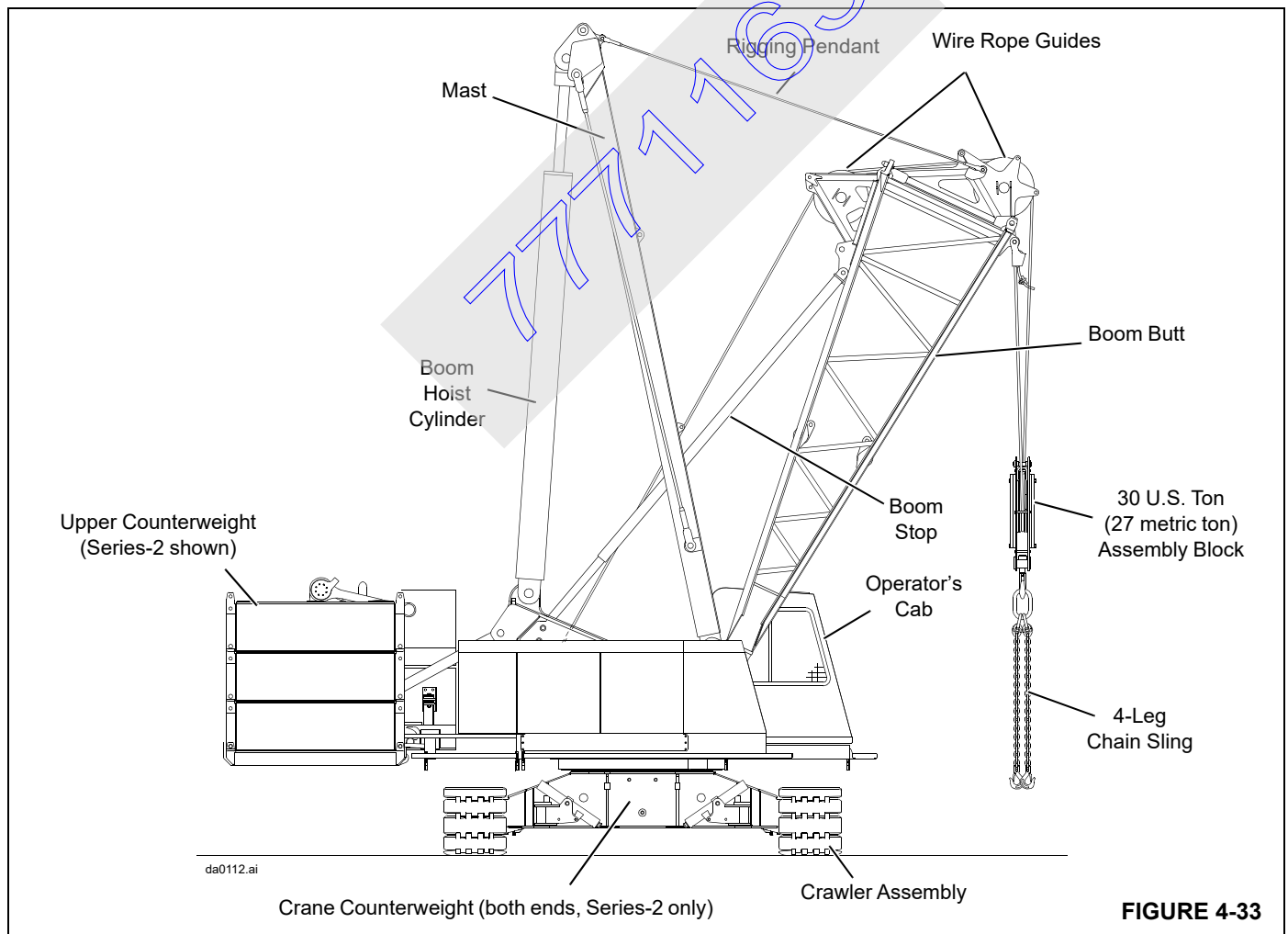
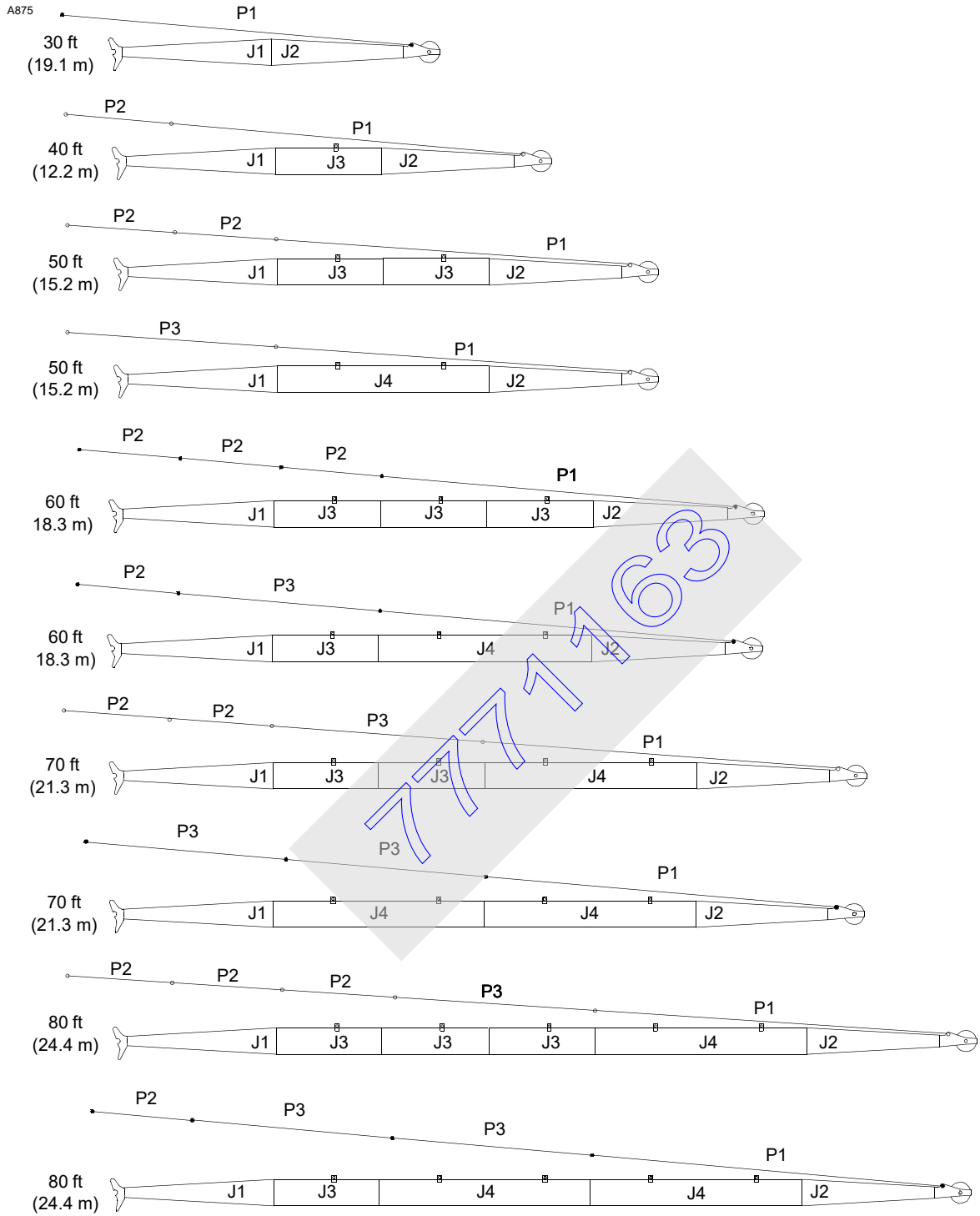

FIGURE 4-33



Section	Type	Length	Pendant	Type	Length
J1	Jib Butt	15 ft (4.6 m)	P1	Basic Jib	30 ft 9 in (9.4 m)
J2	Jib Top	15 ft (4.6 m)	P2	Jib	9 ft 6 in (2.9 m)
J3	Jib Insert	10 ft (3.1 m)	P3	Jib	19 ft (5.8 m)
J4	Jib Insert	20 ft (6.1 m)			

FIGURE 4-34

Blocked Crawler/Extended Outriggers

To prevent 777 crawler crane from tipping, some boom and jib lengths must be raised and lowered over blocked crawlers. See capacity charts for blocked crawler requirements and to Crawler Blocking Diagram in the Crane Operator Manual for instructions.

! DANGER
Tipping Hazard!

Do not attempt to raise or lower boom and jib from or to ground until crawlers are blocked (if required) or outriggers are fully extended and carrier is level.

Jib Assembly Drawing

Jib components (top, inserts, butt, pendants) must be assembled in proper sequence according to this topic and the Jib Assembly drawing in this section. See Figure 4-34 and Figure 4-37 to determine quantity and length of inserts and pendants required for various jib lengths.

A minimum boom length of 80 ft (24.4 m) is required for jib attachment (see applicable Jib Lifting Capacity Chart for boom and jib length limitations).

Identifying Jib Sections and Pendants

Jib sections are marked for proper identification as follows (Figure 4-35, View A):

Past Production:

Jib number, part number, and manufacturing code stamped into two connectors (diagonally opposite) on both ends of each insert and on end of top and butt.

Current Production:

Jib number, part number, and manufacturing code stamped into a plate mounted on all four chords of each section.

Pendants are marked for proper identification as shown in Figure 4-35, View B.

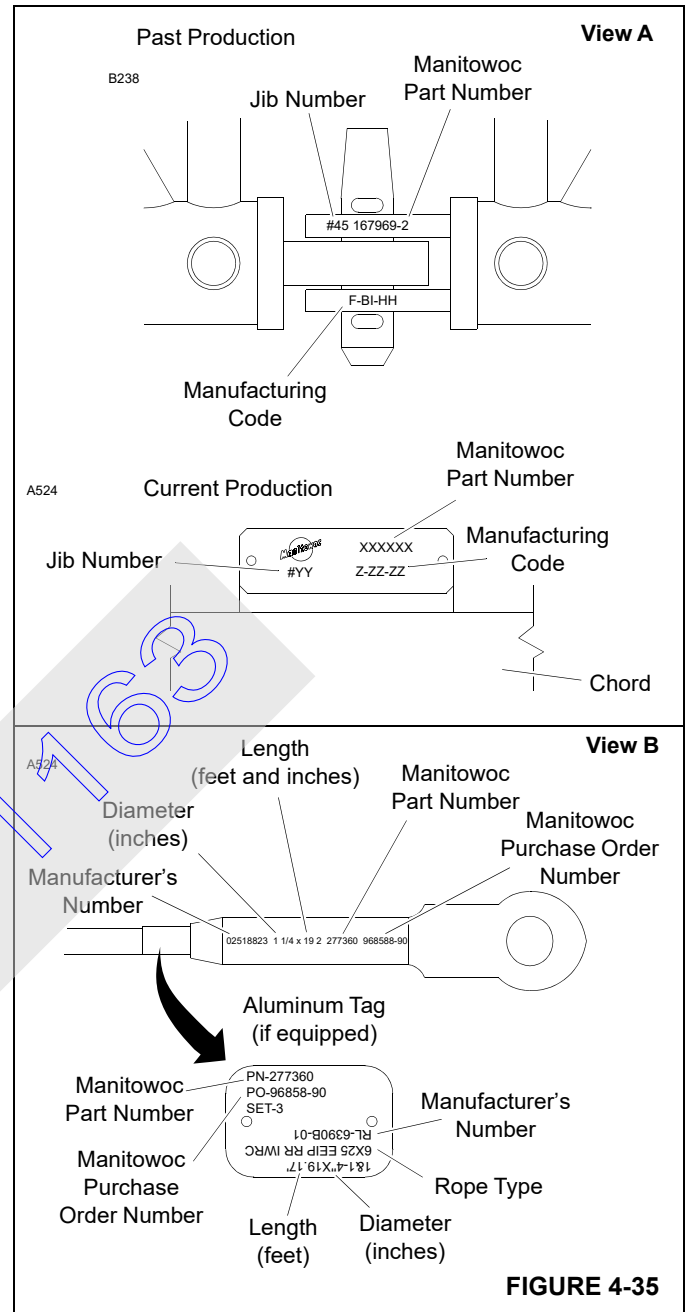

FIGURE 4-35

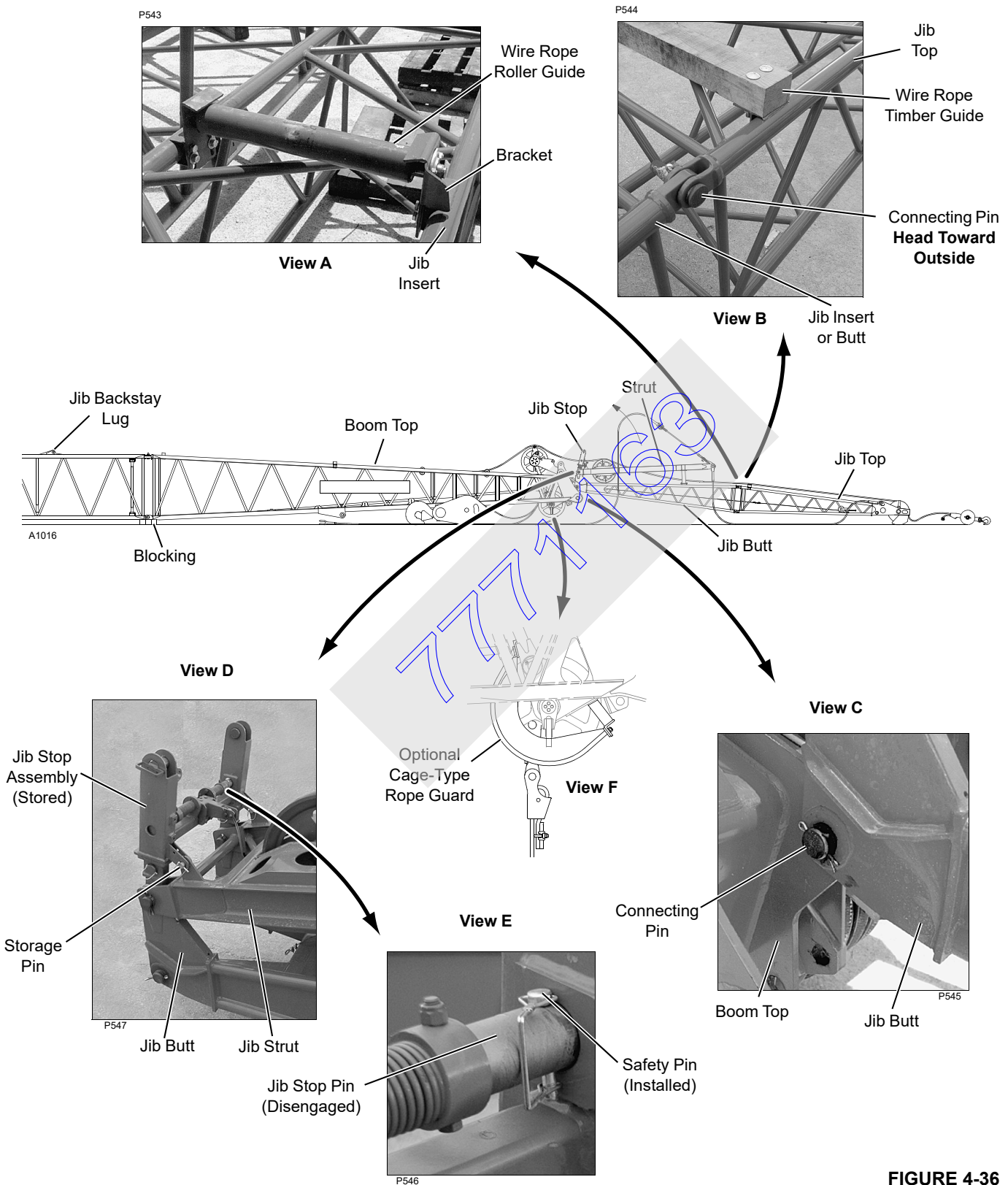

FIGURE 4-36

Installing Jib

See Figure 4-36 for following procedure unless otherwise noted.

Prepare Boom

1. Lower boom onto blocking.
2. Remove load line from upper boom point, if equipped.
3. Remove and store upper boom point (See Boom Rigging Guide in this section).
4. Remove optional cage-type rope guard from lower boom point (View F).
5. Make sure boom insert with jib backstay lugs is installed next to boom top.

Install Jib Butt

NOTE: The jib strut and jib stop assembly are shipped in the stored position on the jib butt (View D).

1. Lift jib butt into position at end of boom top (View C).
2. Align holes in jib butt with holes in boom top and install connecting pins.

Install Jib Inserts



WARNING!

Collapsing Jib Hazard!

To prevent death or serious injury, do not stand on, inside, or under jib during assembly. Always stand outside of jib when installing connecting pins.

NOTE: See Figure 4-34 or to Jib Assembly drawing for required jib inserts and pendants for each jib length.

1. Pin desired length of jib inserts to butt:
 - Wire rope roller guides must face up (View A).
 - Shortest inserts must be closet to butt (Figure 4-34).
 - Pin heads must be toward outside of jib (View B).
2. Wire rope rollers on inserts may be shipped upside down. If necessary, unscrew and reattach brackets and roller rightside up (View A).
3. Block inserts at ground level as assembly progresses.

Install Jib Top

Pin jib top to last insert or butt, depending on jib length:

- Pendent lugs on top must face up.
- Pin heads must be toward outside (View B).
- Wire rope timber guide installed (View B).

Item	Description
1	Backstay Links
2	Basic Backstay Pendants 44 ft 7 in (13.6 m)
3	Offset Links 28 in (711 mm) and pins for 15° Offset
4	Offset Pendants 4 ft 8 in (1.4 m) and pins for 25° Offset

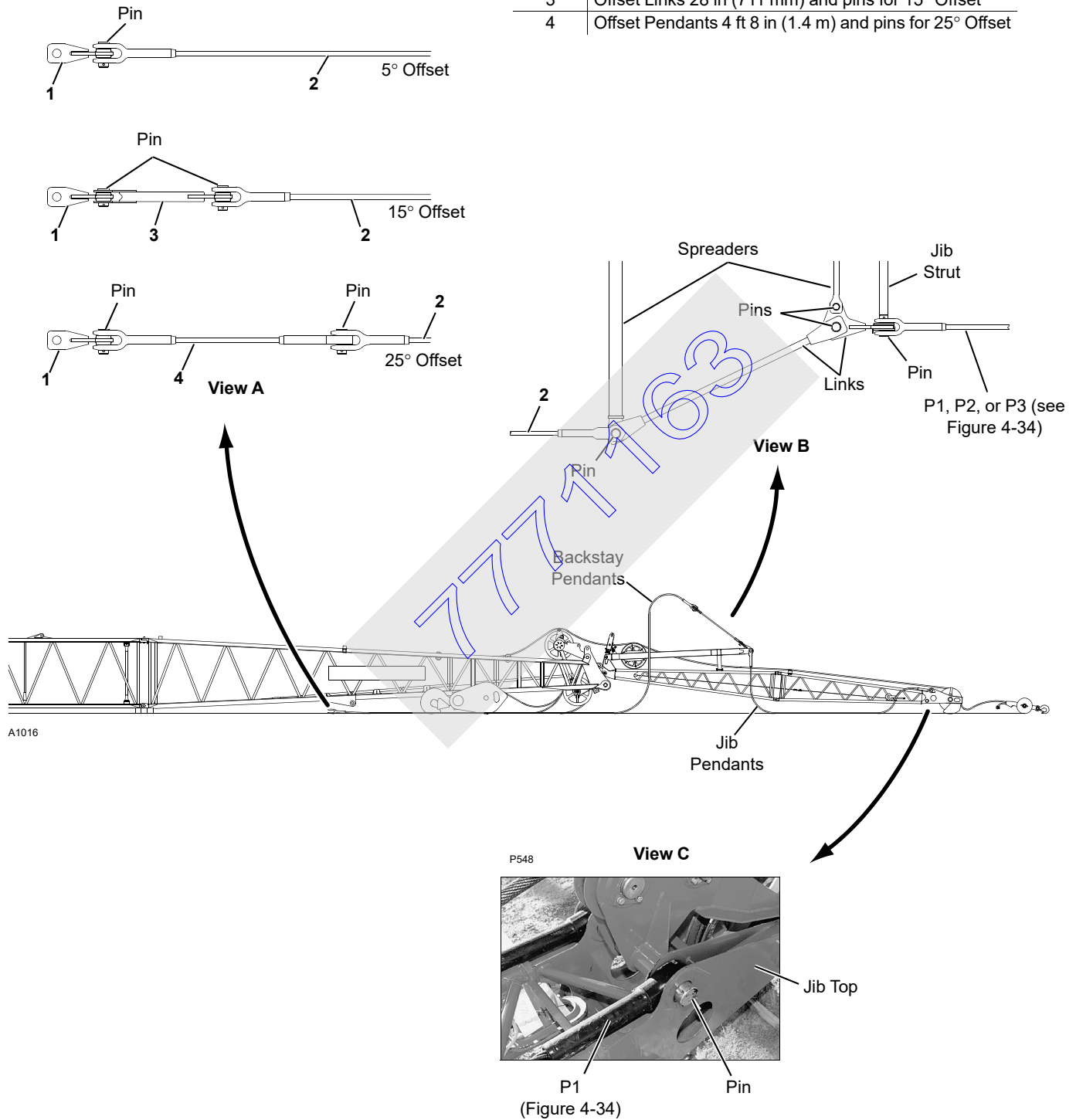

FIGURE 4-37

Install Jib Pendants

See Figure 4-37 for following procedure unless otherwise noted.

NOTE: With the exception of the basic pendants, the jib pendants must be installed in the same sequence as the inserts as shown in Figure 4-34.

The jib pendants are furnished in matched sets of two and must be installed in matched sets — pendant on one side of insert must match pendant on other side of insert.

1. Pin basic jib pendants (P1) to lugs on jib top (View C).
2. Lay basic pendants on ground.
3. Pin remaining jib pendants (P2 and P3, Figure 4-34) to basic pendants (P1). Shortest pendants must be toward butt.
4. Pin jib pendants and proper backstay links to jib strut (View B).

Install Backstay Pendants

1. Pin basic backstay pendants (2), spreaders and links to links on jib strut as shown in Figure 4-37, View B.
2. Lay backstay pendants on ground along top of boom.

Install Jib Offset Links or Pendants

See Figure 4-37, View A for following procedure.

1. For 5° offset, pin link (1) to basic backstay pendants (2).
2. For 15° offset, pin links (1) and links (3) to basic backstay pendants (2).
3. For 25° offset, pin links (1) and pendants (4) to basic backstay pendants (2).

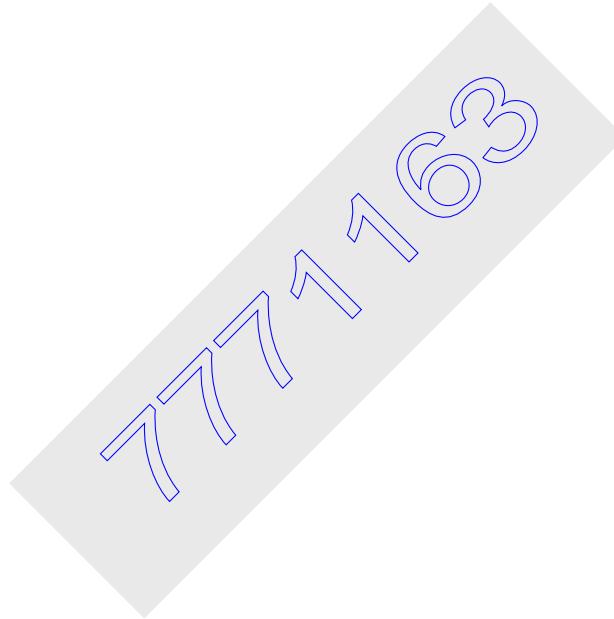

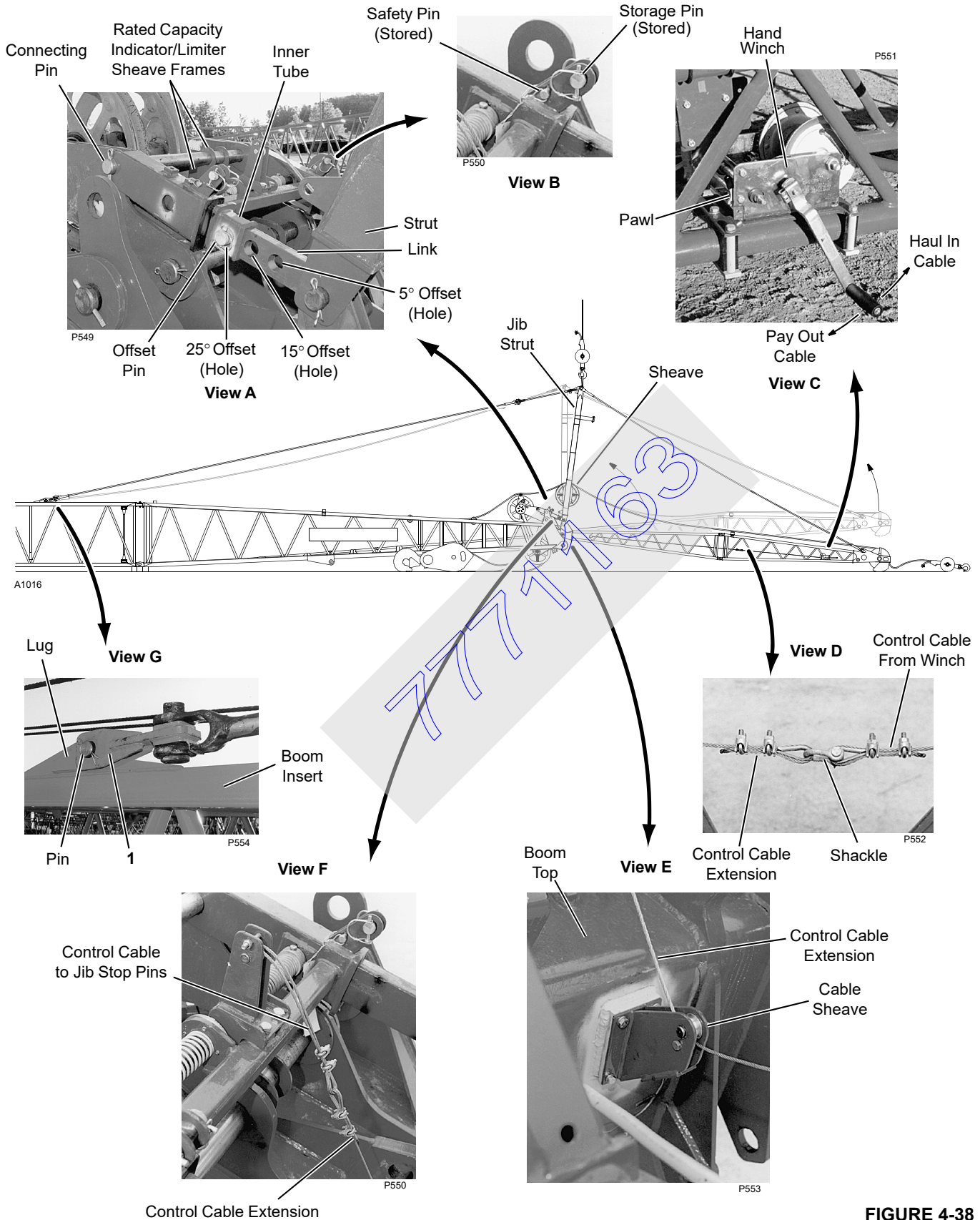

FIGURE 4-38

Raise Jib Strut

See Figure 4-38 for following procedure.

1. Using appropriate slings, attach hook from assist crane to front side of sheave in jib strut.
2. Slowly lift jib strut over center with assist crane. *Use extreme caution not to side load strut while lifting.*
3. If required, raise jib point with an outside assist (another crane or a fork-lift truck) to gain enough slack to allow pinning backstay pendants.
4. Pin backstay links (1) to lugs on boom insert (View G).

Install Jib Stop

See Figure 4-38 for following procedure, unless otherwise noted.

**WARNING****Crushing Injury!**

Jib stop pins are spring engaged. Do not remove safety pins until jib stop assembly is pinned in working position; and, control cables are attached and tensioned.

1. Remove connecting pin (View A) from boom top.
2. Remove storage pins (Figure 4-36, View D) and lower jib stop assembly to boom top. Store storage pins in lugs on jib stop frame (View B).
3. Align holes and pin jib stop frame to lugs on boom top (View A).

Connecting pin must go through connecting holes in rated capacity indicator/limiter sheave frames, if equipped.

4. Adjust jib stop length as follows (View A).
 - a. Remove offset pins.
 - b. Adjust position of inner tubes so holes in tubes are aligned with desired offset holes in links.
 - c. Reinstall offset pins.
5. Connect control cable.
 - a. If not already done, fasten cable sheave to end of boom top as shown in View E.
 - b. Route cable extension from jib stop (View F) through sheave in boom top (View E).
 - c. Using shackle provided, connect cable extension to cable from winch (View D).
6. Using hand winch on jib top (View C), haul in control cable enough to tension jib stop pins so that safety pins can be removed.

7. Remove safety pins from jib stop pins (View E) and store pins in lugs on jib stop frame (View B).
8. Pay out control cable until cable is loose. Cable should be resting on bottom lacing in jib sections. *Pins will not engage if cable is not slack.*

NOTE: The jib stop pins will engage automatically when the jib is raised.

Finish Rigging Boom

Finish assembling the boom, as required. See Boom Rigging Guide in this section for instructions.

Removing Jib**DANGER****Collapsing Jib Hazard!**

To prevent death or serious injury, do not stand on, inside, or under jib during disassembly. Always stand on outside of jib when removing connecting pins.

Support jib properly before removing pins. Block sections at connection points.

Lower Boom and Jib**CAUTION****Jib Stop Damage!**

Do not allow jib point to touch ground until jib stop pins are disengaged.

1. Lower boom until jib point is approximately 1 ft (305 mm) from contacting ground.
2. Using hand winch on jib top (Figure 4-38, View C) haul in control cable until jib stop pins are fully disengaged. Lock handle in position with pawl on winch.

Visually observe that jib stop pins are fully disengaged.
3. Lower boom onto blocking at ground level.
4. Install safety pins in hole in both jib stop pins (Figure 4-36, View E).
5. Pay out control cable until cable is slack.

**WARNING****Crushing Injury Hazard!**

Jib stop pins are spring engaged. Do not attempt to store jib stop until jib stop pins are fully disengaged and safety pins are installed.

6. Disconnect block-up limit electric cord at cable in boom point and at junction boxes in jib point. Store cable on jib butt.

Reconnect block-up limit electric cable to jib at junction box in boom point (See Block-Up Limit Control Assembly Drawing at end of this section).

7. Remove load line and block-up limit chains and weights from jib.

Store Jib Stop

1. Remove shackle to disconnect cable extension from winch cable (Figure 4-38, View D). Store shackle with cable extension.
2. Wind excess cable onto winch.
3. Remove offset pins (Figure 4-38, View A) and pin inner tubes in 5° position.
4. Support jib stop frame so it cannot drop, and remove connecting pin (Figure 4-38, View A).
5. Raise jib stop frame and pin it to strut with storage pins (Figure 4-36, View D).
6. Disconnect cable sheave from end of boom top (Figure 4-38, View E).
7. Store cable sheave and cable extension on jib stop frame.

Lower Strut



WARNING!

Falling Strut Hazard!

Do not disconnect backstay pendants until strut is supported and pendants are slack.

1. Using appropriate slings, attach hook from assist crane to front side of sheave in jib strut.
2. Slowly hoist with assist crane to support strut. Avoid lifting jib butt/boom top in process.

3. If required, raise jib point with an outside assist (another crane or fork-lift truck) to gain enough slack to allow unpinning backstay pendants.

4. Disconnect backstay links (1) from lugs on boom insert (Figure 4-38, View G).

5. Lay backstay pendants on ground alongside boom.

6. Lower jib strut onto jib butt.

7. Disconnect assist crane from sheave in jib strut.

Remove Backstay Pendants

1. Disconnect backstay pendants (2) and remove spreader and links from strut (Figure 4-37, View B).

2. Coil and store backstay pendants for future use.

Remove Jib Pendants

See Figure 4-37 for following procedure.

1. Disconnect jib pendants and remove links and spreader from strut.

2. Disassemble and remove all jib pendants from jib.

3. Coil and store jib pendants for future use.

4. Store all backstay links and spreaders for future use.

Remove Jib Top and Inserts

1. Unpin and remove jib top from jib butt or jib insert (Figure 4-36, View B).

2. Unpin and remove inserts from butt, as required (Figure 4-36, View B).

Remove Jib Butt

1. Support jib butt with assist crane.

2. Unpin and remove jib butt from boom top (Figure 4-36, View C).

WIRE ROPE INSTALLATION

NOTE: Wire rope manufacturer’s recommendations take precedence over information in this section.

Wire Rope Storage

Store wire rope in coils or on reels off the ground or floor in a clean and dry indoor location. If outdoor storage is necessary, the wire rope must be covered with a protective wrapper. Keep the wire rope away from acids, fumes, and other corrosives. Keep the wire rope away from heat that can dry out the lubricant. If the storage period will be long, lubricate the wire rope and perform periodic inspection given in this section at least monthly.

Removing Wire Rope from Shipping Reel

CAUTION!

Wire Rope Damage!

Shipping reel must rotate when wire rope is unwound. Attempting to remove wire rope from a stationary reel can result in a “kinked” wire rope, and wire rope will be ruined.

1. Mount wire rope shipping reel on a shaft supported at both ends by jacks or blocks as shown in Figure 4-39.

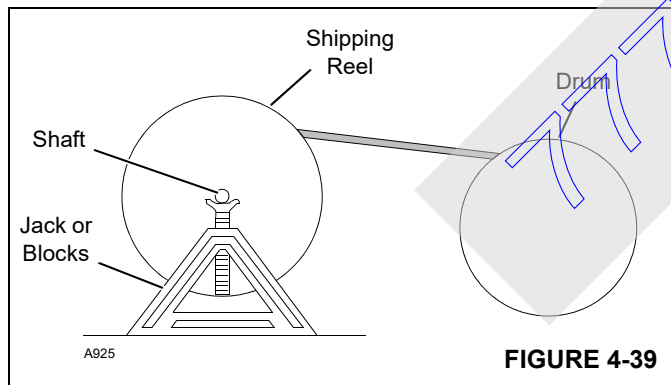

2. Provide a brake at shipping reel (see Figure 4-40) so wire rope can be wound tightly onto drum.

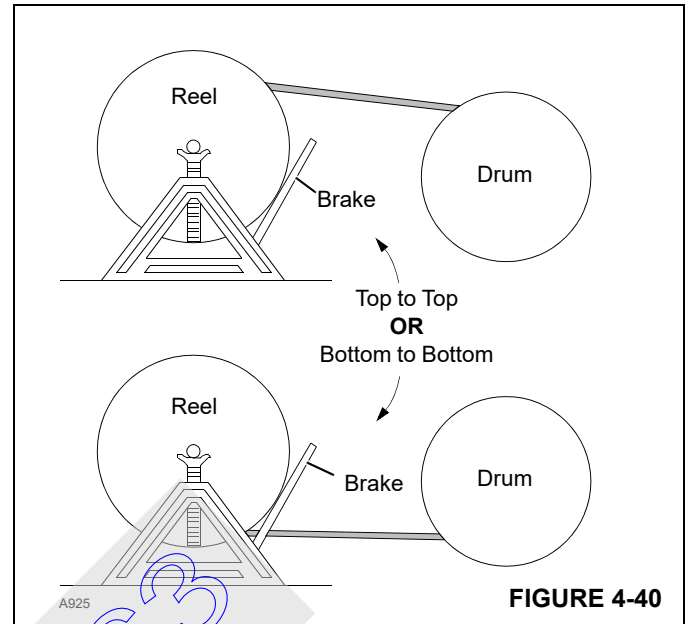

3. Avoid a reverse bend when winding wire rope onto drum. Wind from top of reel to top of drum or from bottom of reel to bottom of drum as shown in Figure 4-40.

4. Avoid dragging wire rope in dirt or around objects that can scrape, nick, cut, or crush wire rope.

Seizing and Cutting Wire Rope

Apply tight seizings of annealed wire to the ends of all wire rope. If not done, the rope wires and strands may slacken. This action will result in overloading of some strands and underloading of others. Bird caging and breakage of the wire rope can occur.

Before cutting wire rope, apply seizings on both sides of the point where the cut will be made. Then cut the wire rope with a torch, rope cutter, or abrasive cut-off wheel.

See Figure 4-41 for:

- Number of seizings to be applied to the ends of wire rope and to both sides of the point where a cut will be made.
- Proper application method. Each seizing should be one rope diameter long.

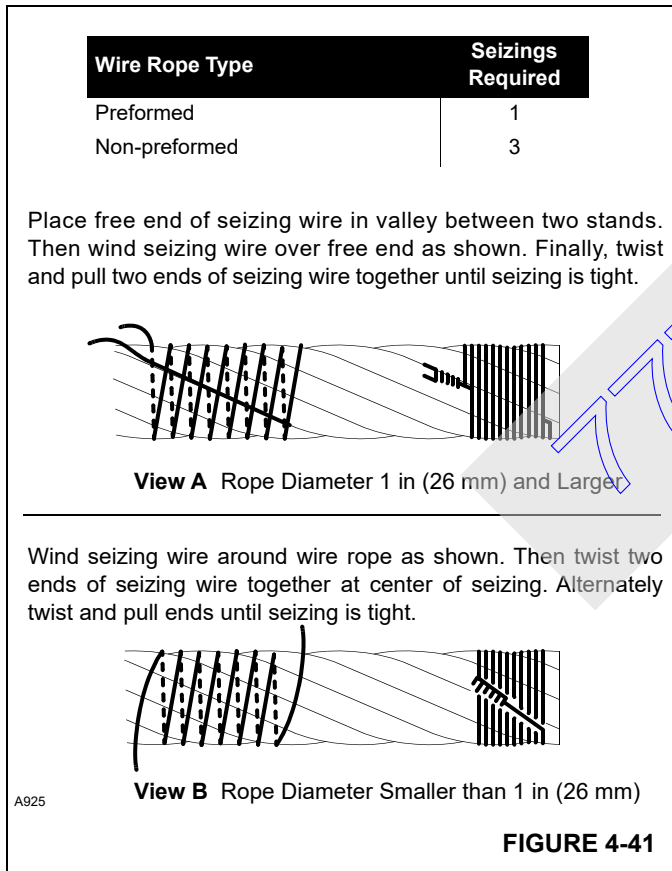

Anchoring Wire Rope to Drum

See Figure 4-42 for following procedure.

Use the correct wedge part number for the size of wire rope being used; see the parts drawing for the boom hoist drums or for the load drum shaft to obtain the correct part number.

1. Assemble wire rope and wedge to drum socket.
2. Tighten wedge, rapping back of wedge with a brass drift pin and hammer.

WARNING!
Falling Load Hazard!

Wire rope can be pulled out of drum if following steps are not taken.

- Install straight wedge so corrugated side is against wire rope.
- Install wedge so end of wire rope extends past end of wedge, but not out of drum socket.
- Make sure seizing is not under wedge. Remove seizing if it interferes with assembly.

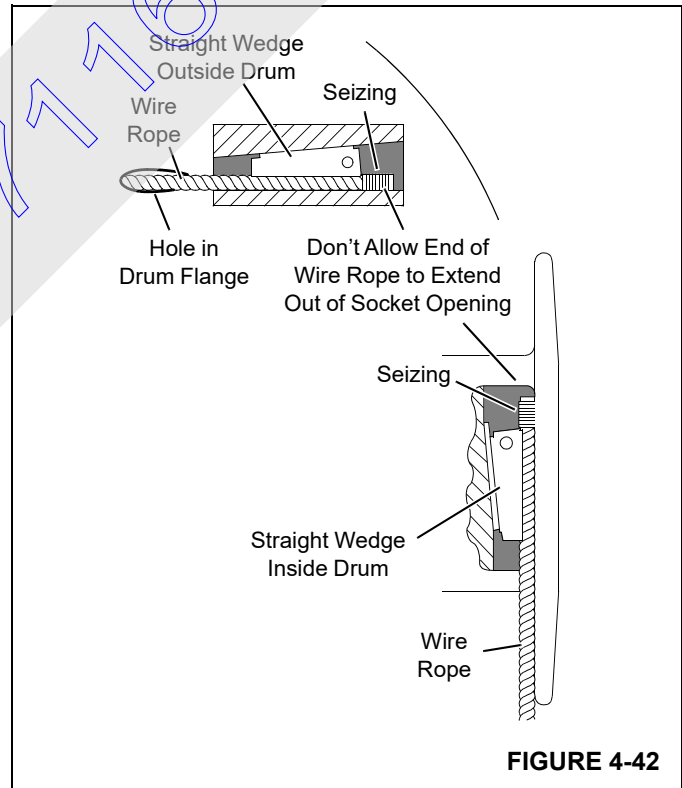

Winding Wire Rope onto Drum

See Drum and Lagging Chart in Capacity Chart Manual for correct size of drum laggings, if used.

See Wire Rope Specifications Chart in Capacity Chart Manual for correct type, size, and amount of wire rope to be installed on load drums.

See Boom Rigging Drawing at end of this section for correct type, size, and amount of wire rope to be installed on boom hoist drums.

1. Carefully inspect drums and all rope guides, rollers, and sheaves for defects that can cause wire rope to wear or be cut. If defects cannot be fixed, replace faulty parts.
2. Apply tension to wire rope as it is wound slowly onto drum.

First wrap must be tight against drum flange for approximately three-fourths of drum diameter (see Figure 4-43).

3. Tap adjacent wraps against each other with a soft metal or wooden mallet.

Use extreme care not to put twists or turns in wire rope; allow rope to assume its natural lay.

CAUTION!

Wire Rope Damage!

Voids or spaced wraps in first layer (see Figure 4-43, View B) will permit movement and a wedging action with subsequent layers. Wedging action will cause crushing and abrasion of wire rope.

Never allow wire rope to "cross wind" on drums.

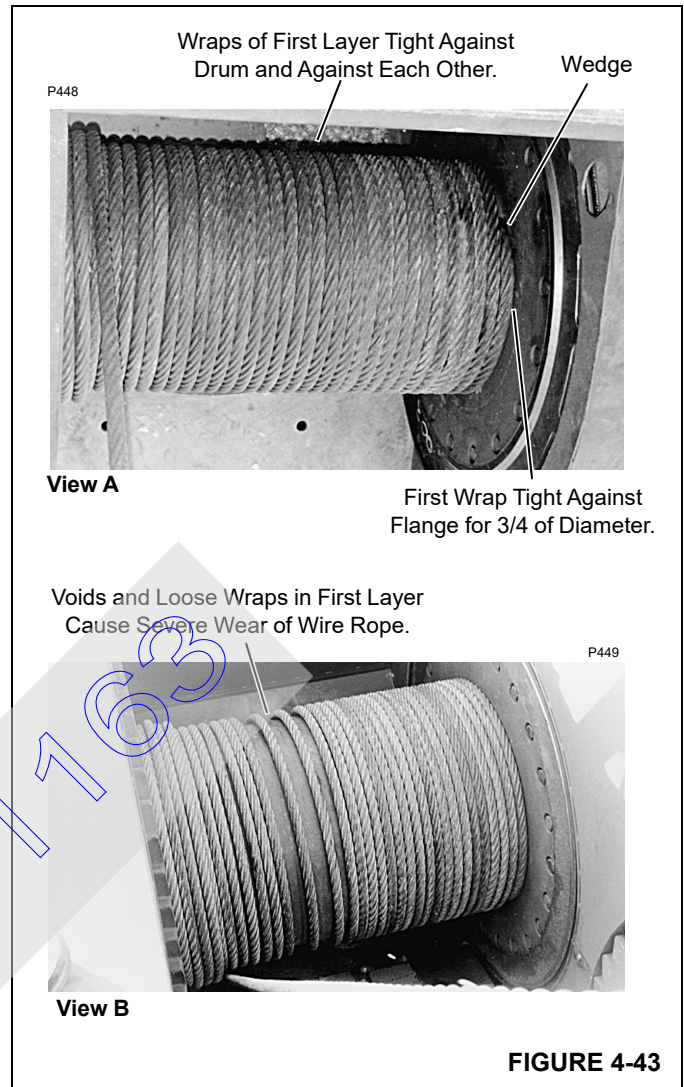

Anchoring Wire Rope to Wedge Socket

! WARNING
Falling Load Hazard!

- Inspect all parts prior to use. Do not use parts that are cracked or otherwise defective.
- Remove minor nicks, burrs, or rough edges from socket, wedge, or pin by lightly grinding. Do not reduce original dimensions by more than 10%.
- Do not reinstall shipping material (bolt, plastic strap or wire) in hole of wedge or socket after assembling. Discard these materials because they can prevent wedge from tightening in socket.
- Only use a wedge and socket which are correct size for wire rope being used. Do not mix and match parts from one assembly with parts from another assembly.
- Terminator™ socket and wedge has “go” and “no-go” holes to check for proper rope size.
- Attach wire rope clip to dead end of wire rope after assembling wire rope to wedge and socket.

See Figure 4-44 for following procedure.

1. Assemble wire rope and wedge to socket so live end of wire rope is in a straight line with socket pin hole. *Do not assemble WRONG as shown.*
2. Allow dead end of wire rope to extend past end of socket amount shown.

3. Allow wire rope to assume its natural lay.
4. Pull against wedge and live end of wire rope enough to tighten wedge in socket.

Use a brass hammer to seat wedge and wire rope as deep into socket as possible.

5. Attach a wire rope clip to dead end of wire rope using one of the RIGHT methods shown. Rope clip will aid in preventing wire rope from being pulled out of socket.

NOTE: Use Right Method A only if wire rope clip is small enough to be securely tightened to dead end. Right Method C is only for a Terminator wedge socket.

6. After socket is pinned in place, hoist load slowly so wedge seats tight. *Do not shock load socket and wedge.*

! WARNING
Falling Load Hazard!

Wire rope can break if following precaution is not observed:

- Do not attach dead end of wire rope to live end of wire rope with wire rope clip. Wire rope clip will transfer load from live side of wire rope to dead end, seriously weakening attachment.

TL (Tail Length)
Standard 6 to 8 Strand Wire Rope
Minimum of 6 rope diameters, but not less than 6 in (152 mm).
Rotation Resistant Wire Rope
Minimum of 20 rope diameters, but not less than 6 in (152 mm).

T (Rope Clip Nut Torque)

inch (mm)	Wire Rope/Clip Size			
	7/8 (22,23)	1 (25,4)	1-1/8 (28,58)	1-1/4 (31,75)
	Torque			
* ft/lbs (kN/m)	225 (0,30)	225 (0,30)	225 (0,30)	360 (0,49)

* Tightening torque values shown are based on threads being clean, dry and free of lubrication.

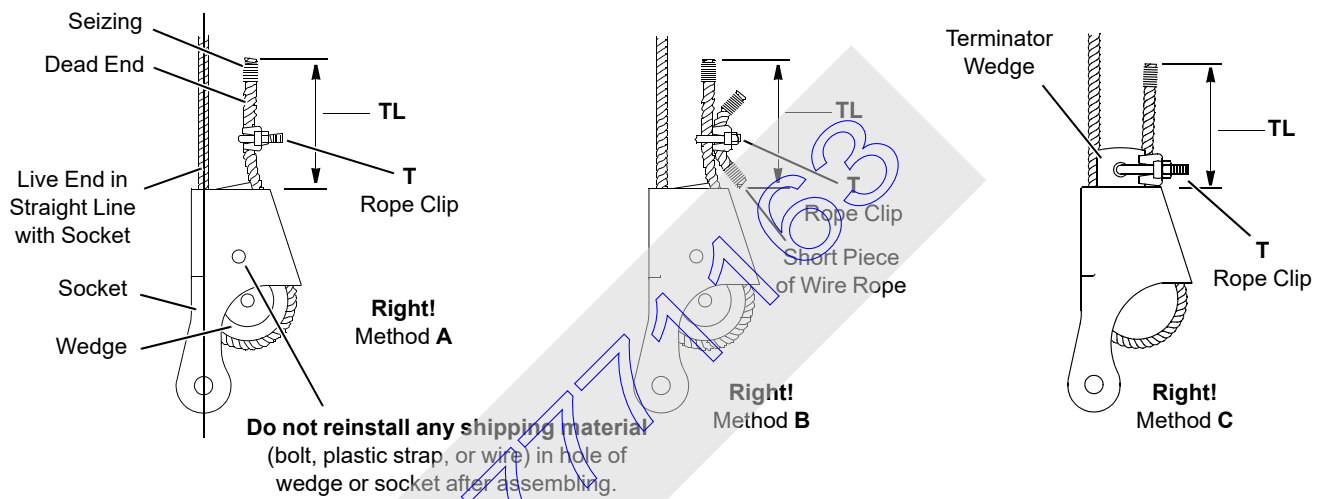

ALL ARE DANGEROUS AND PROHIBITED!

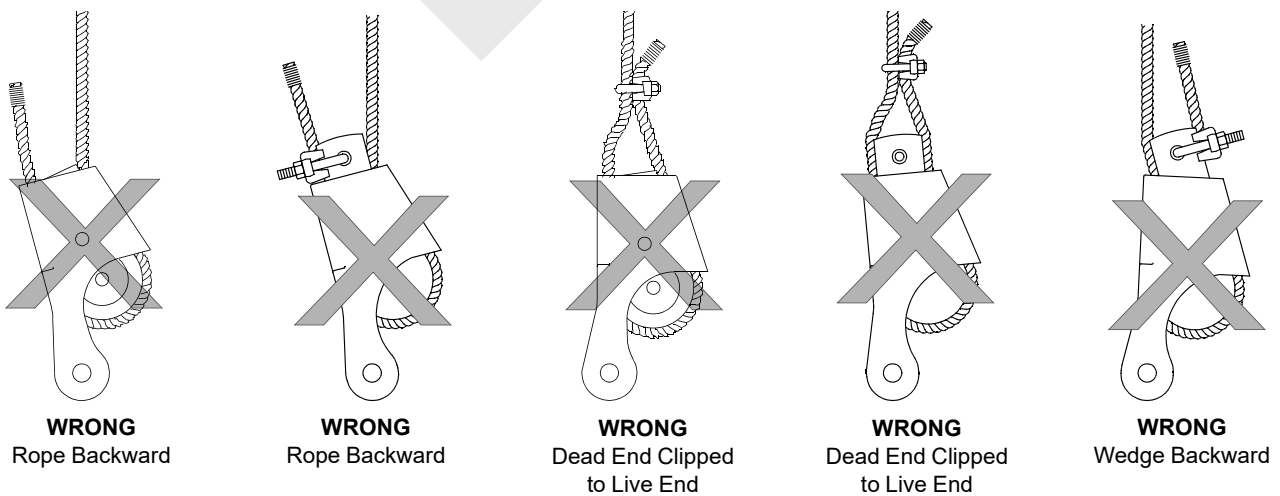

A925

FIGURE 4-44

Breaking in Wire Rope

After installing a new wire rope, break it in by operating it several times under light load and at reduced speed. This practice allows the wire rope to form its natural lay and the strands to seat properly.

NOTE: Wire rope will stretch during the break-in period, reducing the wire rope's diameter as the strands compact around the core.

The dead wraps of wire rope on the drum can become slack during operation, even if the utmost care is used during installation of the wire rope. This slackening is caused by the normal stretch that occurs in a new wire rope under tension and periodically throughout the wire rope's life from release of the load.

When slackness is noted, tightly wind the dead wraps of wire rope onto the drum. If left uncorrected, a wedging action with subsequent layers will occur, and the resultant abrasion may cause broken wires in the dead wraps.

PAD EYE USAGE FOR WIRE ROPE REEVING

See Figure 4-45 for following procedure.

General

Some rotation-resistant wire rope supplied by Manitowoc is equipped with a No. 1.5 pad eye welded to the leading end of the wire rope.

A sucker-line can be attached to the pad eye to make it easier to reeve the load block.

Safety

1. For No. 1.5 pad eye, do not exceed 1,000 lb (4.45 kN) single line pull.
2. Make sure sucker line and rope clips are rated for at least 1,000 lb (4.45 kN) line pull.
3. Inspect pad eye prior to each use. **Replace it if:**
 - Any original dimensions have changed (Figure 4-45).
 - Cracks or breaks exist in metal or weld.



WARNING

Flying Part Hazard!

Pad eye on end of wire rope has been provided **for reeving purposes only**. Any other use is neither intended nor approved.

Pad eye can break and fly apart with considerable force if it is overloaded, not used properly, or not maintained properly.

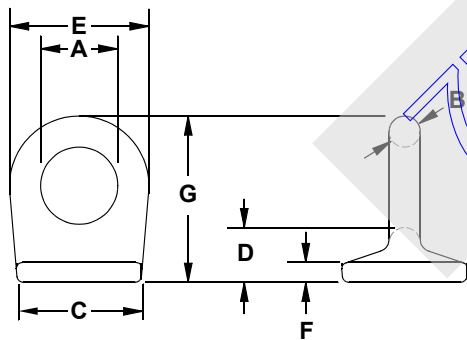
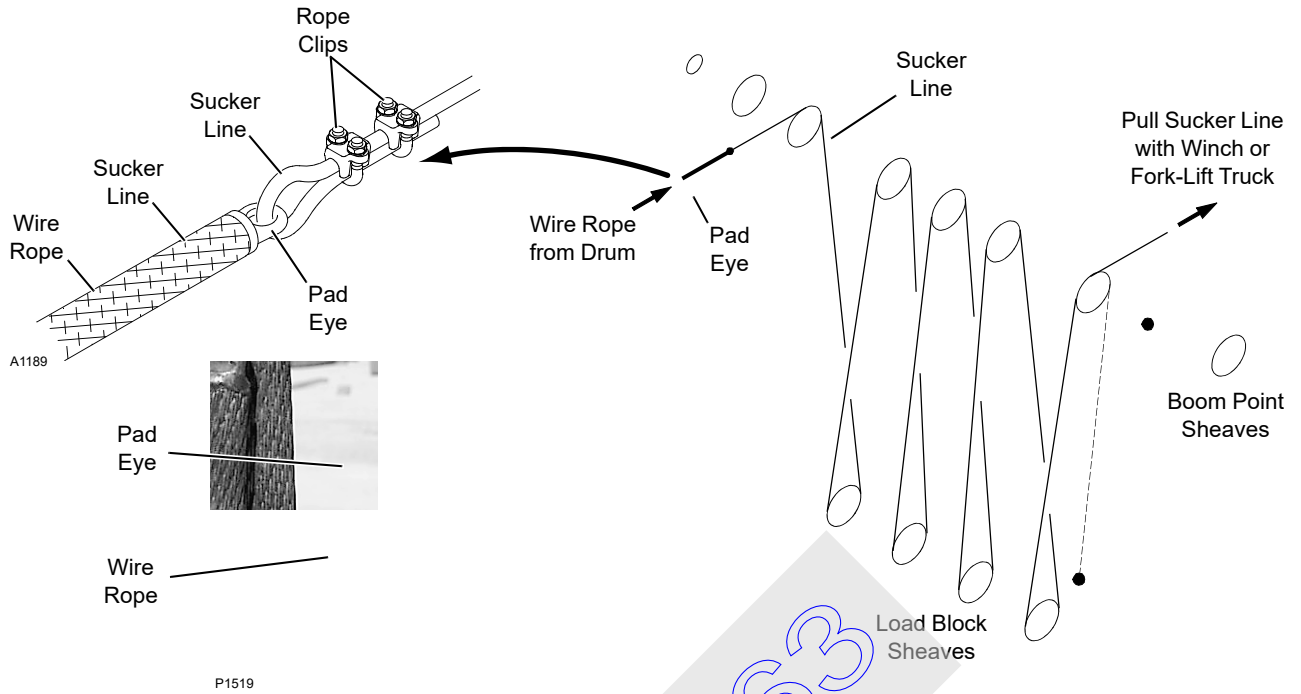

No. 1.5 Pad Eye			
Item	Inch	mm	
Approximate Capacity 1,220 lb (553 kg)			
A	5/8	16,00	
B	1/4	6,35	
C	1	25,40	
D	7/16	11,18	
E	1-1/8	28,70	
F	1/16	4,06	
G	1-5/16	33,27	

No. 1 Pad Eye			
Item	Inch	mm	
Approximate Capacity 1,220 lb (553 kg)			
A	3/8	9,65	
B	1/4	6,35	
C	7/8	22,40	
D	13/32	10,40	
E	7/8	22,40	
F	1/8	3,30	
G	1-1/32	25,40	

No. 2 Pad Eye			
Item	Inch	mm	
Approximate Capacity 2,600 lb (1 179 kg)			
A	3/4	19,05	
B	3/8	9,65	
C	1-1/16	26,92	
D	1/2	12,70	
E	1-1/2	38,10	
F	3/16	4,83	
G	1-5/8	41,26	

FIGURE 4-45

LOAD LINE REEVING

Reeving Diagrams

See Figure 4-48 for suggested reeving diagrams.

See Figure 4-46 for component identification and dead-end locations in the boom and jib.

CAUTION

Wire Rope Damage!

Avoid wire rope damage from improper fleet angle or contact with adjacent parts. Do not hoist load block or hook and weight ball any closer to boom or jib points than specified on Range Diagram (see Capacities Section of Capacities Chart Manual).

Wire Rope Specifications

See Wire Rope Specifications chart in operator's cab for following information:

- Parts of line required for various loads.
- Wire rope lengths and hoisting distance notes for various parts of line.
- Maximum spooling capacity of load drums.

Wire Rope Installation

See Wire Rope Installation and Maintenance in this section for following instructions:

- Anchoring wire rope to drums.
 - Installing wire rope on drums.
 - Anchoring wire rope to wedge sockets.
-



WARNING!

Falling Load Hazard!

Avoid damage to wire rope or wire rope guide. Route wire rope from load drums *over top* of proper sheaves in wire rope guides as shown in Figure 4-47. Failing to route wire rope as shown can cause wire rope to break and load to fall.

Guide Sheave Identification

See Figure 4-47 for identification of the wire rope guide sheaves on the boom.

Sheaves must be positioned at indicated dimensions to ensure proper fleet angles.

Load Pin Sheaves

The wire rope from the load drums must be routed through the load pin sheaves as shown in the diagrams in Figure 4-46. *Failing to route wire rope properly will result in faulty rated capacity indicator/limiter readings.*

Universal Anchor Joint

A universal anchor joint (Figure 4-46) is available for the #134 jib to provide a dead-end location for 2-part reeving from the jib point.

See Universal Anchor Joint in this section for a complete description of the universal anchor joint and for safety information.



WARNING!

Falling Load Hazard!

Load block capacity must be equal to or greater than weight of load to be handled. Load block can fail if overloaded, allowing load to fall.

Load Blocks

Two different size load blocks are available from Manitowoc:

- 15 USt (13.6 t) hook and weight ball.
- 30 USt (27 t) with one sheave. This is the same block used for self-erecting. It can be used for 2-part reeving from the jib point (dead end at universal anchor joint in jib top).
- 60 USt (54 t) with two sheaves.
- 175 USt (158.8 t) with six sheaves.

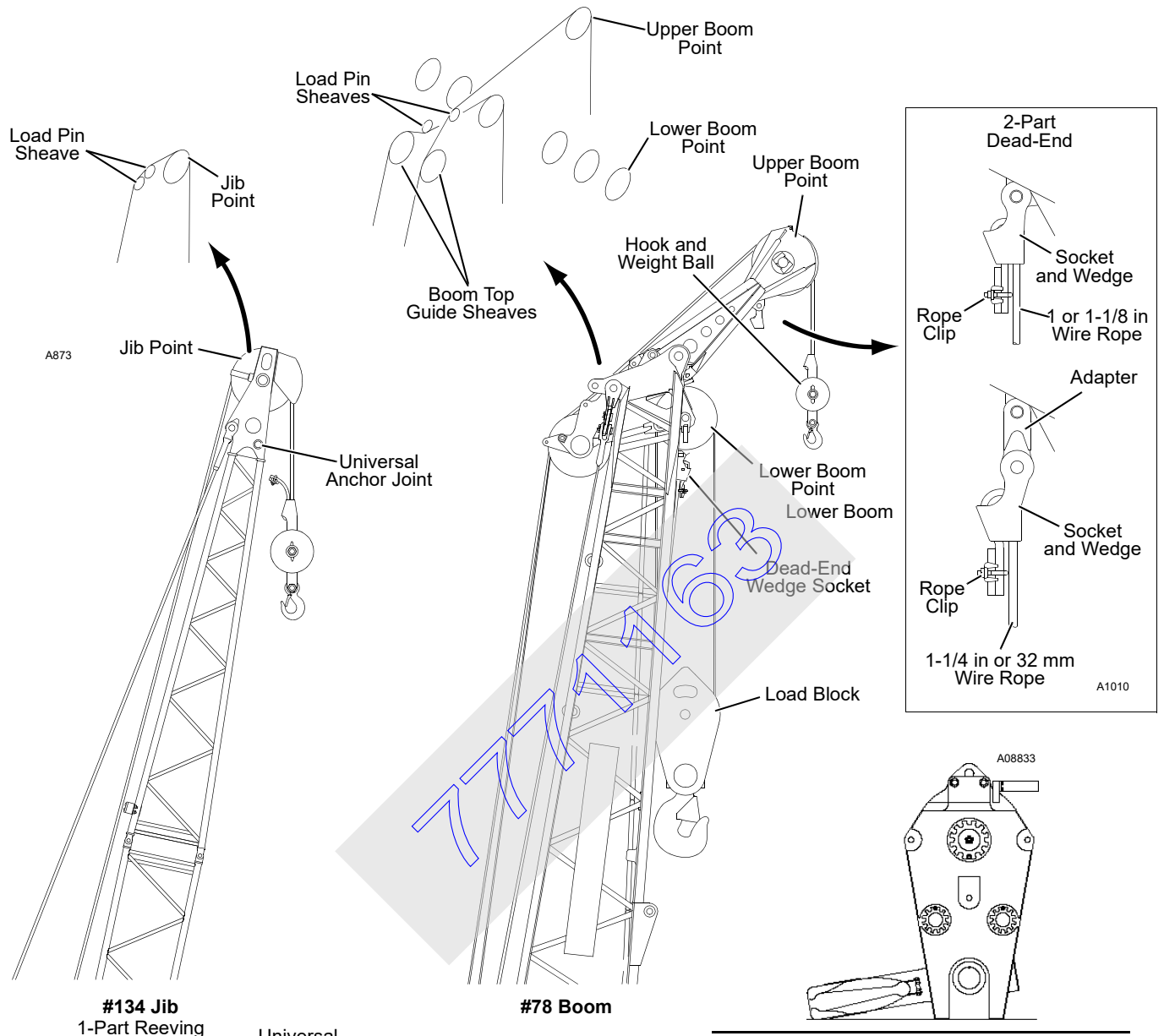

#134 Jib
1-Part Reeving

#78 Boom

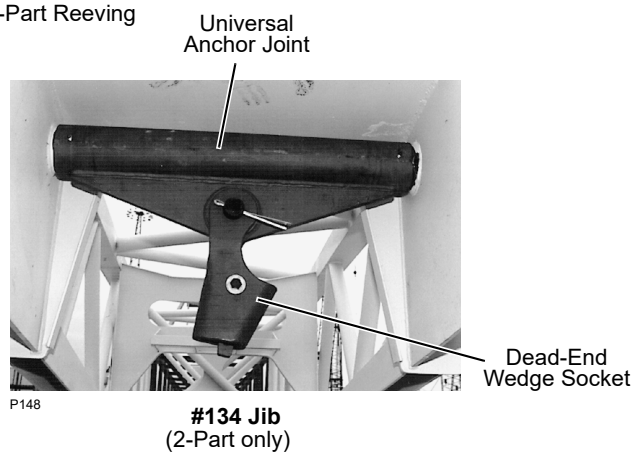

#134 Jib
(2-Part only)

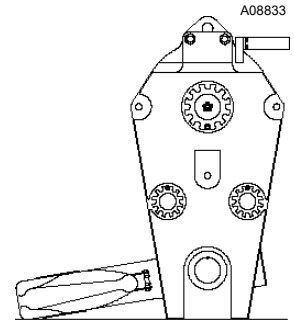

! WARNING

Avoid Death or Serious Injury!

Exercise care when block is standing in vertical position, as the potential for tipping exists. Potential causes of tipping are unstable work area, boom movement and the reeving process.

If work area is unstable, lay block flat on side plate.

FIGURE 4-46

**Boom Top Guide Sheaves (S1 and S2)
Must Be Positioned at Dimensions Given in This Table**

Front Drum to Sheave S1		
Lead Line To:	Dimension A	Note
S3 (View C)	5/8 in (16 mm)	1
S4 (View C)	4-1/16 in (103 mm)	—
S5 (View C)	7-23/32 in (196 mm)	—
Fixed Jib Point (View E)	11-7/16 in (291 mm)	2
Rear Drum to Sheave S2		
Lead Line To:	Dimension B	Note
S6 (View C)	7-23/32 in (196 mm)	—
S7 (View C)	4-1/16 in (103 mm)	—
S8 (View C)	5/8 in (16 mm)	1
Upper Boom Point (View F)	10 in (254 mm)	3
Upper Boom Point (View F)	11-7/16 in (291 mm)	4
Fixed Jib Point	Not Applicable (see View D)	—
Auxiliary Drum to Sheave S2		
Lead Line To:	Dimension B	Note
S6 (View C)	7-23/32 in (196 mm)	4
S7 (View C)	4-1/16 in (103 mm)	5
S8 (View C)	5/8 in (16 mm)	3
Upper Boom Point (View F)	10 in (254 mm)	—
Upper Boom Point (View F)	11-7/16 in (291 mm)	—
Fixed Jib Point (View E)	11-7/16 in (291 mm)	2
Auxiliary Drum to Sheave S1		
Lead Line To:	Dimension A	Note
S3 (View C)	5/8 in (16 mm)	1
S4 (View C)	4-1/16 in (103 mm)	—
S5 (View C)	7-23/32 in (196 mm)	—

Load Line Identification	
F	Front
R	Rear
A	Auxiliary

A1010

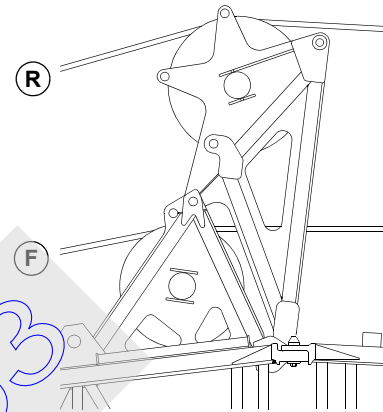

View A
Boom Butt Guide Sheaves

Gap between clamps must be equal on both sides. Torque bolts lubricated with SAE 20 oil to 120 ft-lb (1 751 Nm)

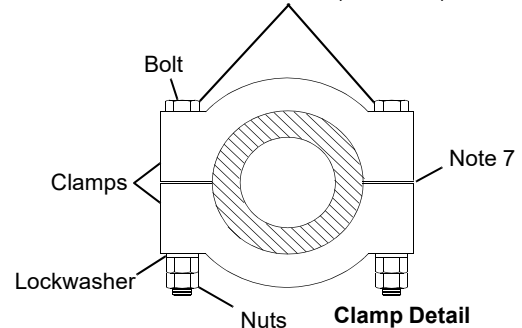

Notes

1. For this position, sheave bearing must be tight against wire rope guide frame.
2. Requires optional guide sheave S9 shown in View E.
3. This position is for lead line to upper boom point without load sensing sheave. If front drum is routed to sheave S5, then sheaves S1 and S2 must be separated by one set of clamps.
4. This position is for lead line to upper boom point with load sensing sheave. If front drum is routed to sheave S5, then sheaves S1 and S2 must bear against each other.
5. Optional sheave S9 must be removed when not in use.
6. Load line from rear drum cannot be routed to fixed jib when optional sheave (S9) is used.
7. Gap must be equal on both sides of clamps.

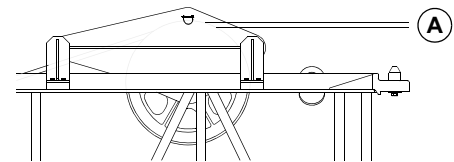

View B
10 ft (3.1 m) Insert Guide Sheave

FIGURE 4-47

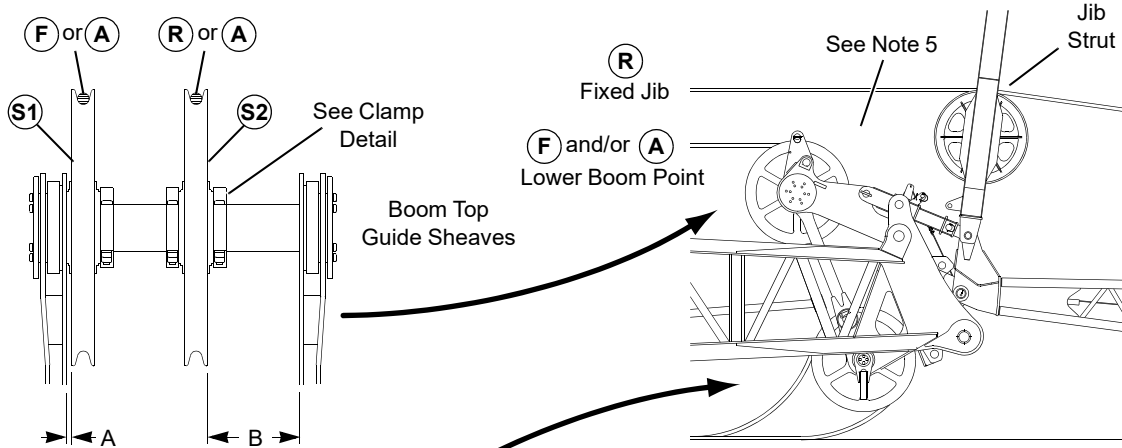

View D
Two or Three Load Lines with Fixed Jib

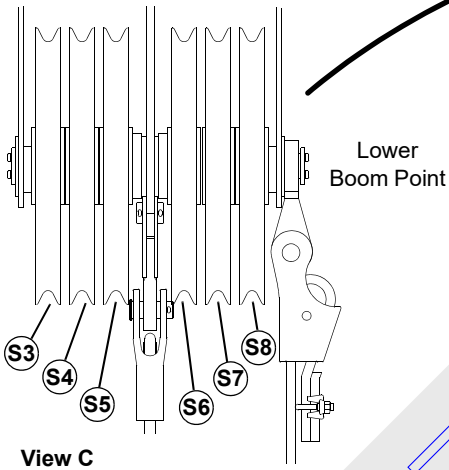

View C

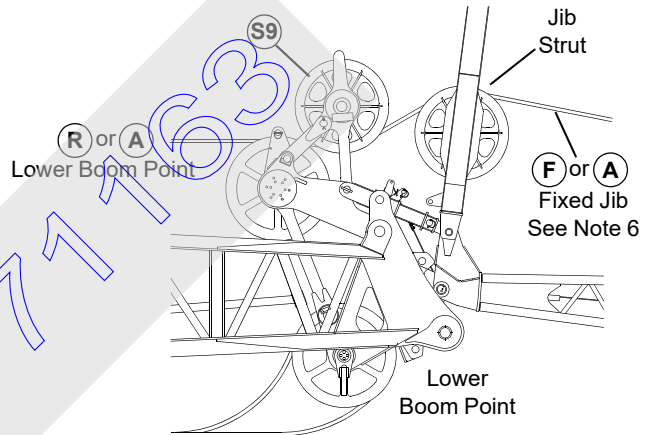

View E
Two Load Lines with Fixed Jib
When Optional Sheave (S9) is Installed

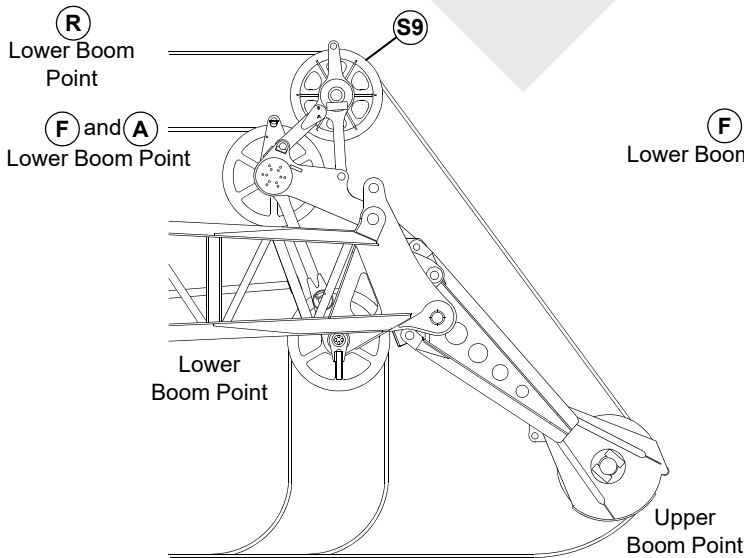

View G
Three Load Lines
with Upper Boom Point

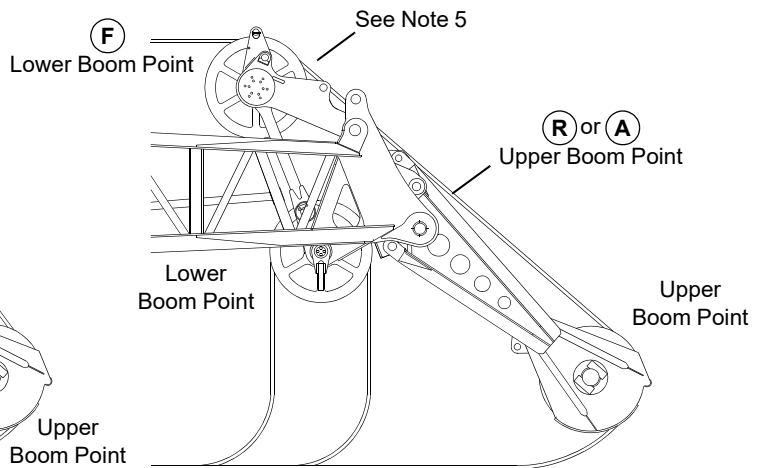

View F
Two Load Lines with Upper Boom Point

FIGURE 4-47 continued

A1010

4

A1010

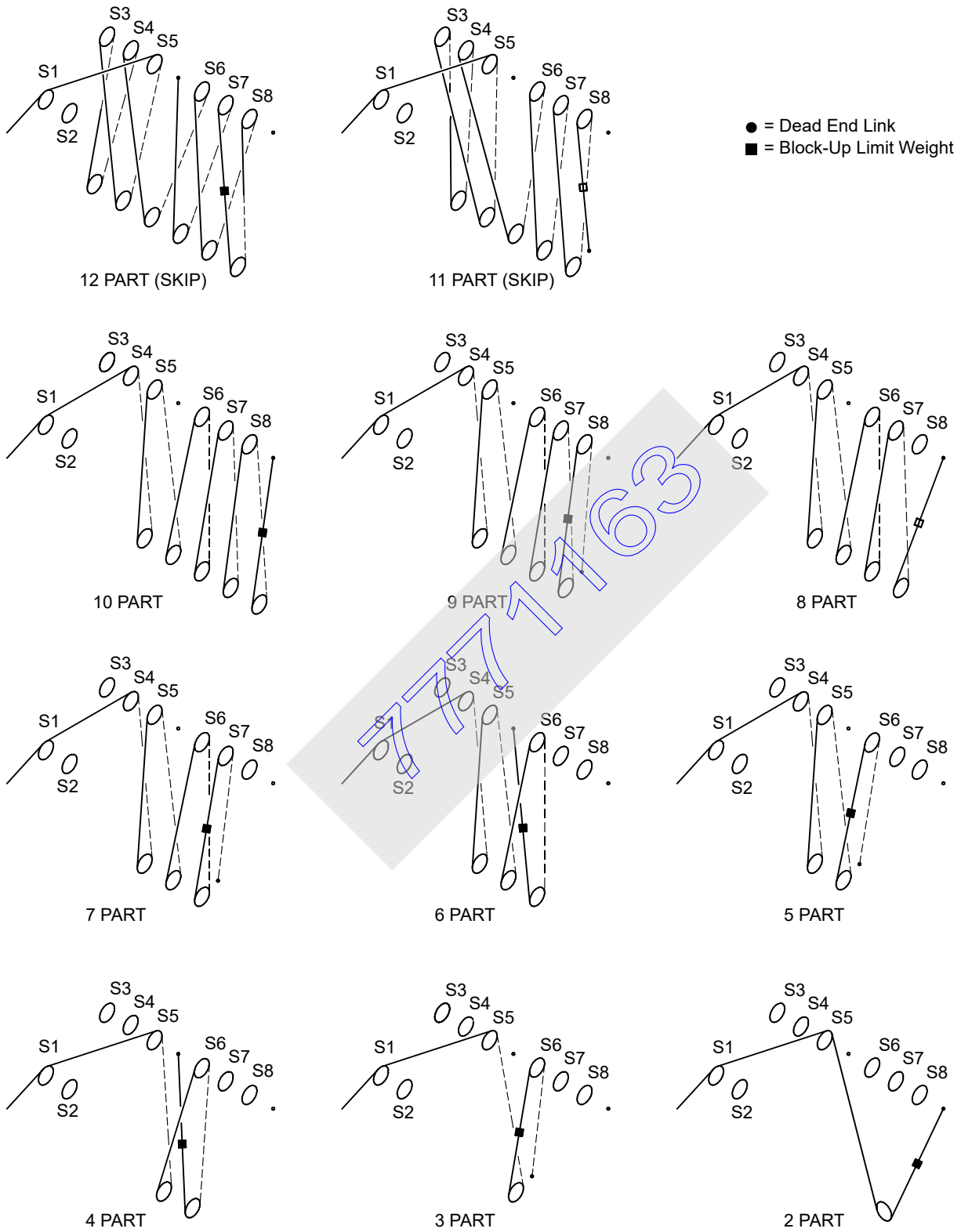

FIGURE 4-48

THIS PAGE INTENTIONALLY LEFT BLANK

777163

CLAMSHELL REEVING

CAUTION

Wire Rope Damage!

Failing to observe following precautions can result in damage to wire rope and wire rope guide sheaves.

General

For clamshell operation, perform following steps:

- Remove jib or upper boom point.
- Remove block-up limit chains and weights. Connect electric cables from limit switches to shorting plugs on boom top junction box.
- Remove load sensing sheaves for rated capacity indicator/limiter.
- Install boom point wire rope roller guide as shown in Figure 4-49.

- Position boom top wire rope guide sheaves as shown in Figure 4-50. *Sheaves must be positioned at indicated dimensions to ensure proper fleet angles.*
- Route wire rope from load drums as shown in Figure 4-50.

Wire Rope Specifications

See Wire Rope Specifications chart in Capacity Chart Manual for following information:

- Wire rope lengths and hoisting distance notes for various parts of line.
- Maximum spooling capacity of load drums.

Wire Rope Installation

See Wire Rope Installation and Maintenance for following instructions:

- Anchoring wire rope to drums.
- Installing wire rope on drums.
- Anchoring wire rope to wedge sockets.

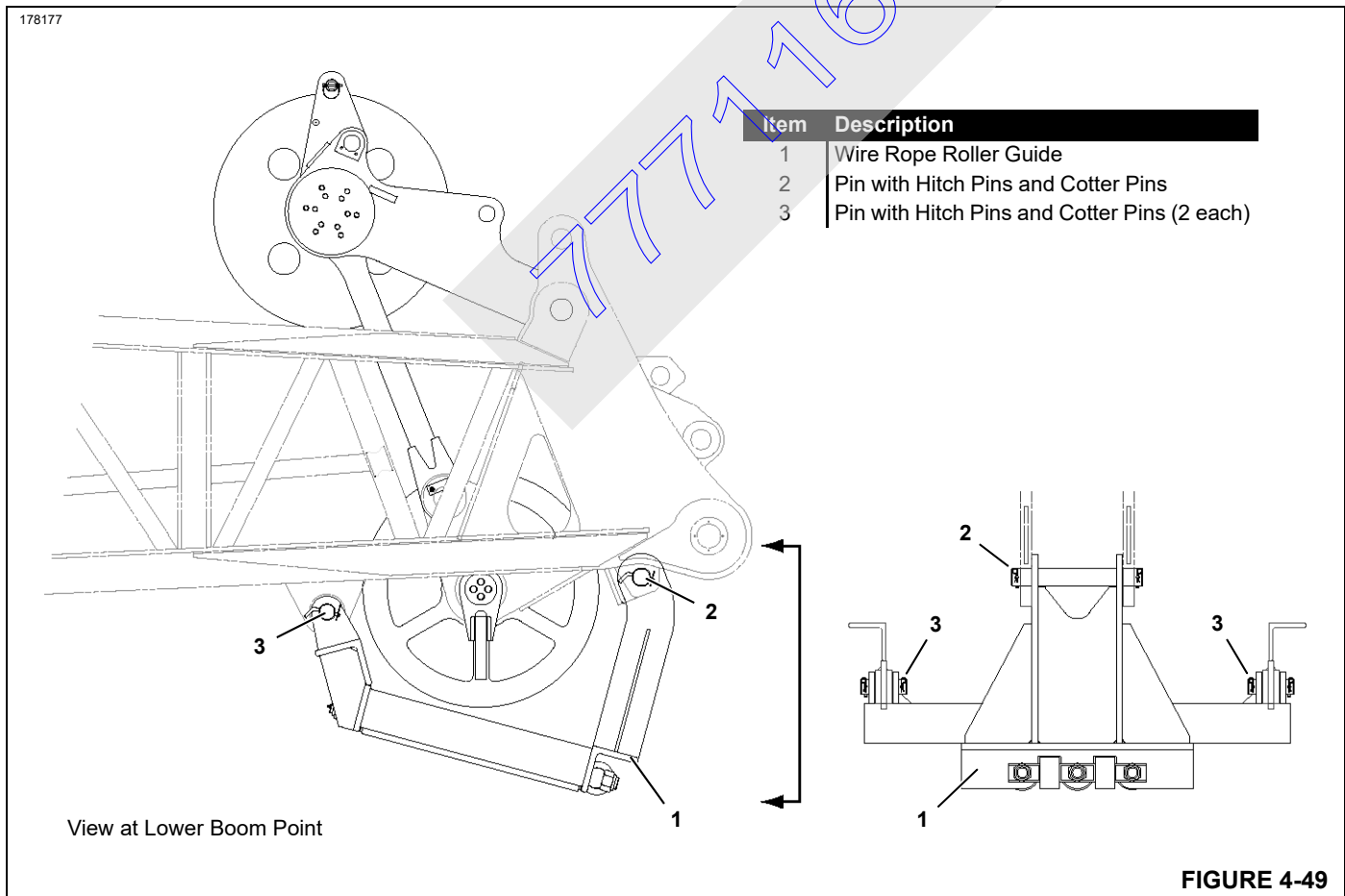

Item	Description
1	Boom Top Wire Rope Guide
1a	Right Side Sheave
1b	Left Side Sheave
2a	Clamp
2b	Bolt
2c	Lock Washer
2d	Nut
3	Lower Boom Point
R	Rear Drum Load Line
F	Front Drum Load Line
D	7.71 in. (196 mm)

Gap between clamps must be equal on both sides. Torque bolts lubricated with SAE 20 oil to 120 ft-lb (163 Nm).

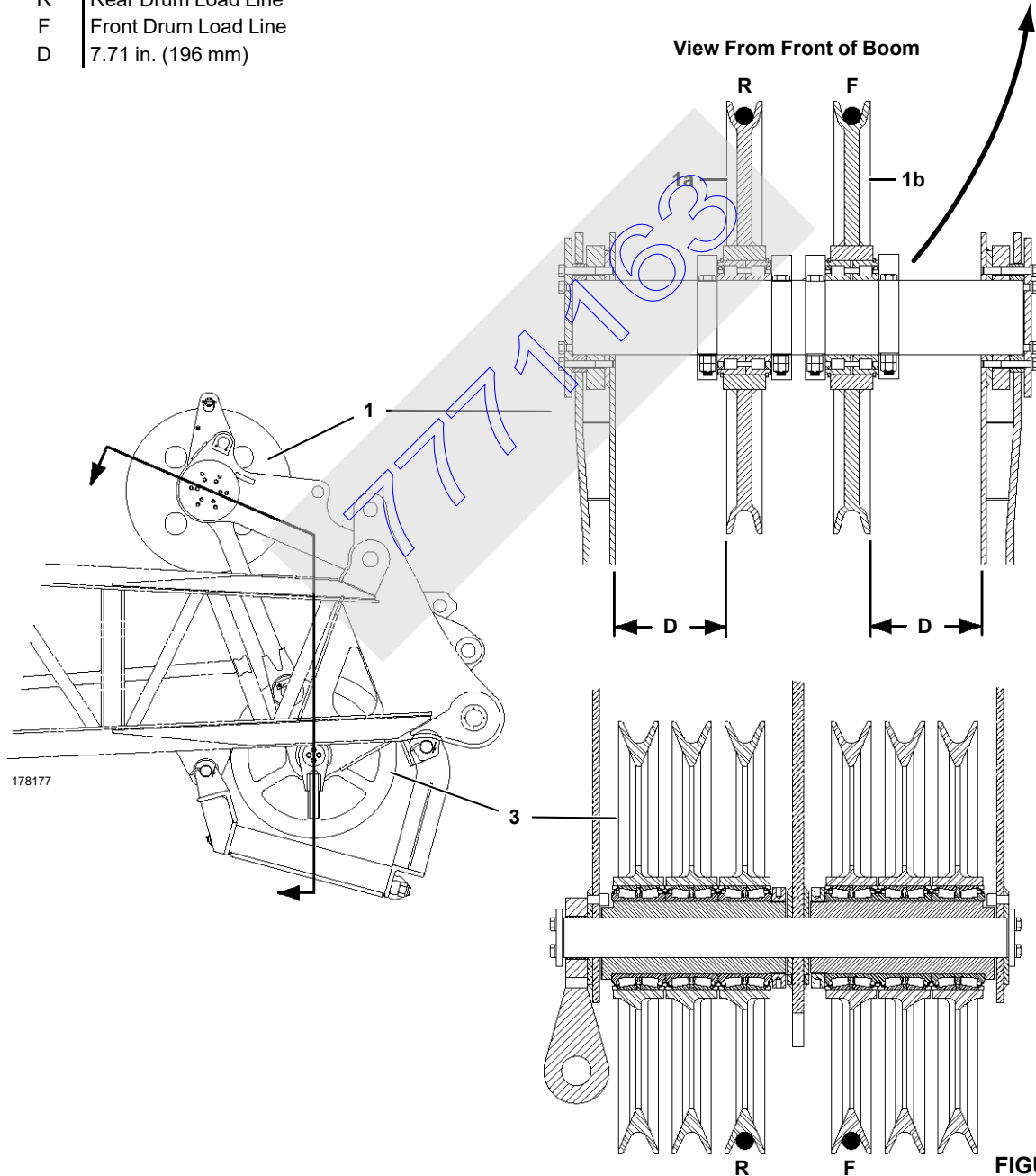
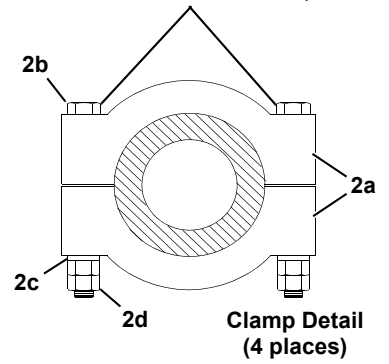

FIGURE 4-50

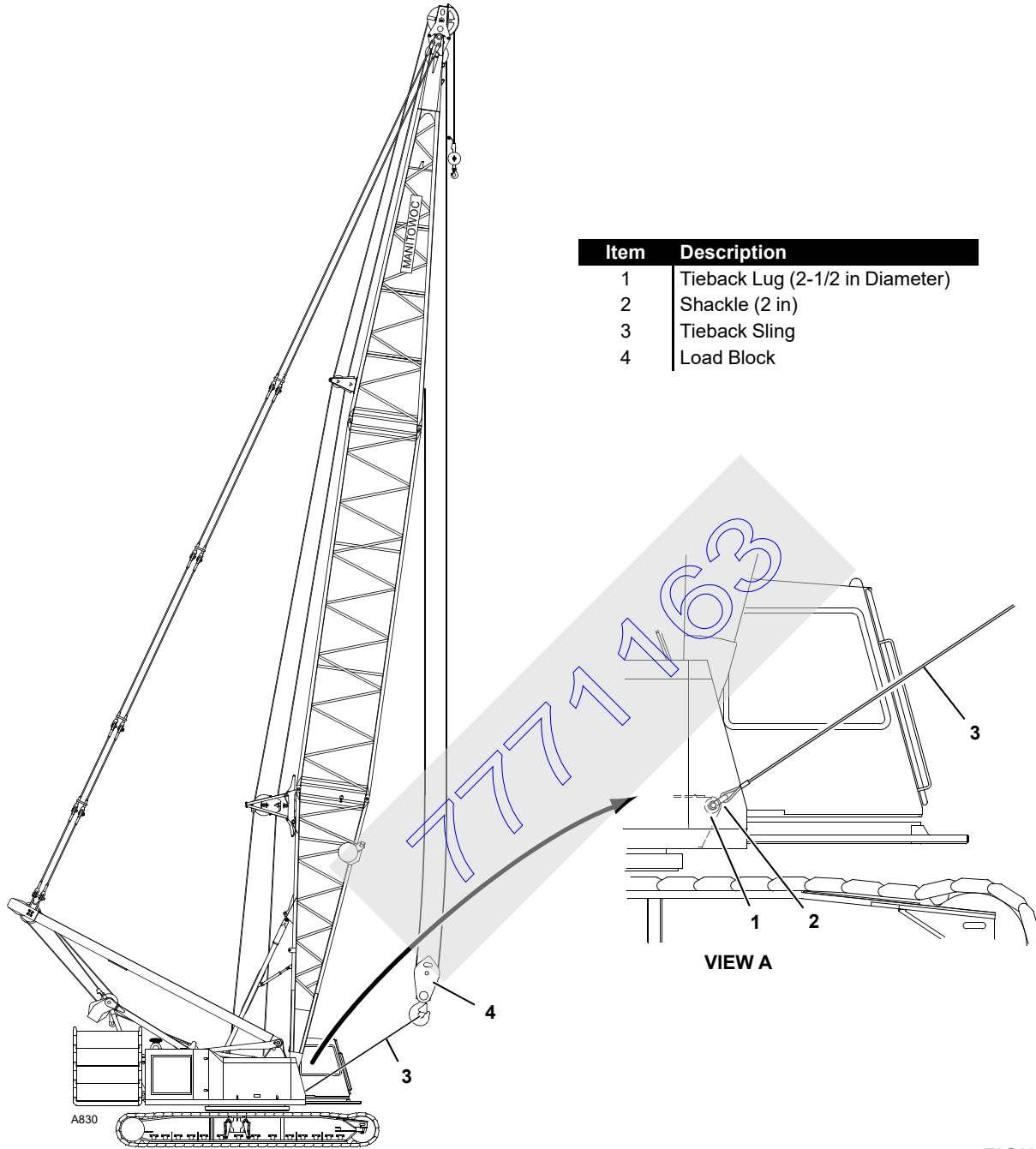

FIGURE 4-51

LOAD BLOCK TIEBACK

Manitowoc provides a lug on the front of the rotating bed (Figure 4-51, View A) for tying back the load block when not in use.

Specifications

Shackle

See Figure 4-51 for identification of tieback hole diameter and shackle size.

Sling Length

The sling must be long enough to connect it to a shackle in the tieback hole and to the hook of the freely suspended load block. This will prevent personnel from having to swing the block in, toward crane, to make the connection.

Both pins and two slings must be used to prevent side loading boom.

Sling Capacity

The slings must be capable of supporting the weight of the load block and 1/2 the weight of the wire rope suspended from the boom point. When sizing slings, take into account the dynamic affects of traveling and swinging the crane. **It is the crane users responsibility to calculate this load.**

CAUTION

Avoid damage to boom:

- Haul in load line only until tieback sling(s) is taut. Purpose of tieback is only to prevent load block from swinging when not in use.
- Do not tighten load line to point that load line rubs against lacings in boom sections or load block can bounce into lacings.

Operator, be aware that as you boom down load lines and tieback sling will tighten even more. Pay out load line while booming down so that you don't pull load block into boom. Damage to lacings or chords could result.

777163

UNIVERSAL ANCHOR JOINT

The dead-end socket and wedge can be anchored to any of the following locations in the boom and jib point, depending on the type of operation (see Figure 4-52):

1. Link (if equipped) in boom or jib point for liftcrane operation.
2. Lug welded inside boom or jib point directly behind boom or jib point shaft for liftcrane operation.
3. Universal anchor joint located 30 in. (0.8 m) to 72 in. (1.8 m) behind boom or jib point. This location provides greater separation between the load lines which reduces twisting of the load. The universal anchor joint is used for magnet, clamshell, grapple and liftcrane operation requiring a 2-part load line. For container handling or rock tray operation, a double hanger universal anchor joint is used.

NOTE: Movement of the dead-end socket on the link or lug (1 and 2 above) is in two directions only – forward and back (see Figure 4-52). Movement of the dead-end socket on the universal anchor joint (3 above) is in four directions – forward, back and sideways (see Figure 4-52).

If the anchor link or lug in the boom or jib point has been used for any duty-cycle work with a 2-part load line, check for cracks due to side bending loads. Consult with factory for repair procedure.

If the boom or jib point is not prepared for the universal anchor joint, the boom or jib top is neither designed for nor intended for duty-cycle work.

For liftcrane operation requiring 3-parts of load line or greater, it is necessary to remove the universal anchor joint. This step will prevent interference of the universal anchor joint with the wire rope at high boom angles.

! WARNING
Falling Load Hazard!

Do not operate as liftcrane at high boom angle with universal anchor joint in place. Interference of wire rope with universal anchor joint can damage wire rope causing rope to break and load to fall.

For wire rope size and maximum load of universal anchor joint, see appropriate wire rope chart, capacity chart, or rigging drawing.

! WARNING
Falling Load Hazard!

Do not dead-end a 2-part load line to anchor link or lug in boom or jib point for magnet, clamshell, grapple or other operations requiring rapid swing cycles. Sideways motion may break link or lug causing load to fall.

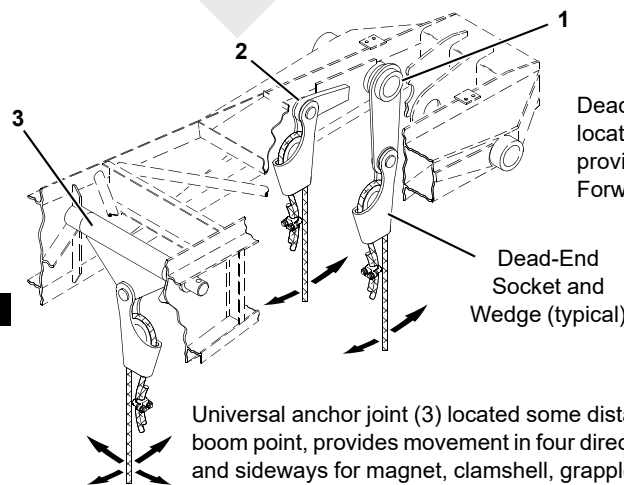

Dead-end anchor link (1) and lug (2) located in or behind lower boom point provides movement in two directions only. Forward and back for liftcrane operation

Dead-End Socket and Wedge (typical)

Item	Description
1	Anchor Link (lower boom point)
2	Anchor Lug
3	Universal Anchor Joint

Universal anchor joint (3) located some distance behind lower boom point, provides movement in four directions. Forward, back and sideways for magnet, clamshell, grapple, liftcrane and other operations requiring a 2-part load line (duty-cycle work).

FIGURE 4-52

SECTION 5 LUBRICATION

TABLE OF CONTENTS

Lubrication 5-1

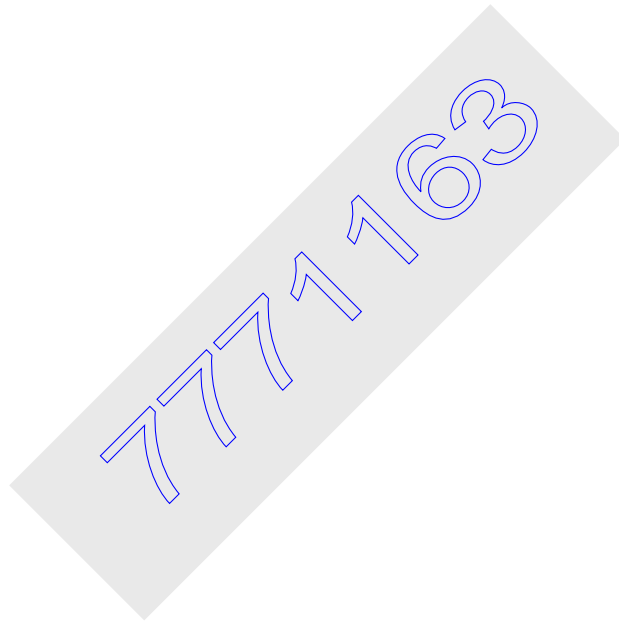

THIS PAGE INTENTIONALLY LEFT BLANK

777163

SECTION 5 LUBRICATION

LUBRICATION

See F2107 at the end of this section.

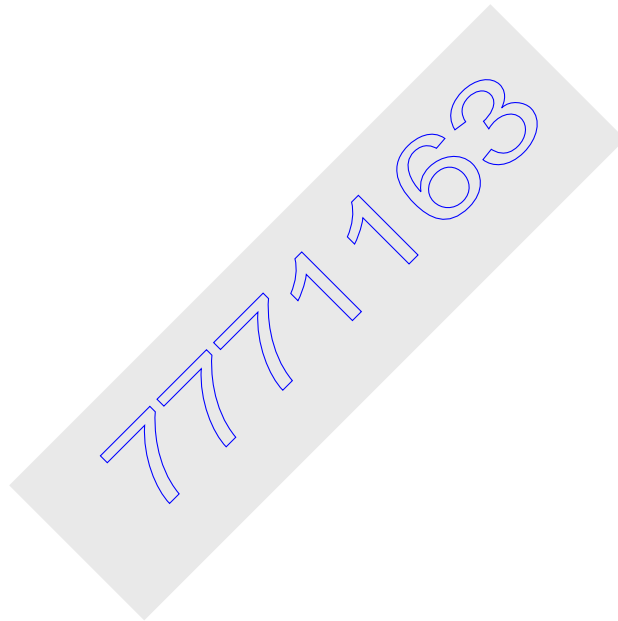

THIS PAGE INTENTIONALLY LEFT BLANK

777163

SECTION 6 MAINTENANCE CHECKLIST

TABLE OF CONTENTS

Inspection and Maintenance Checklist	6-1
Fiberglass Maintenance	6-1

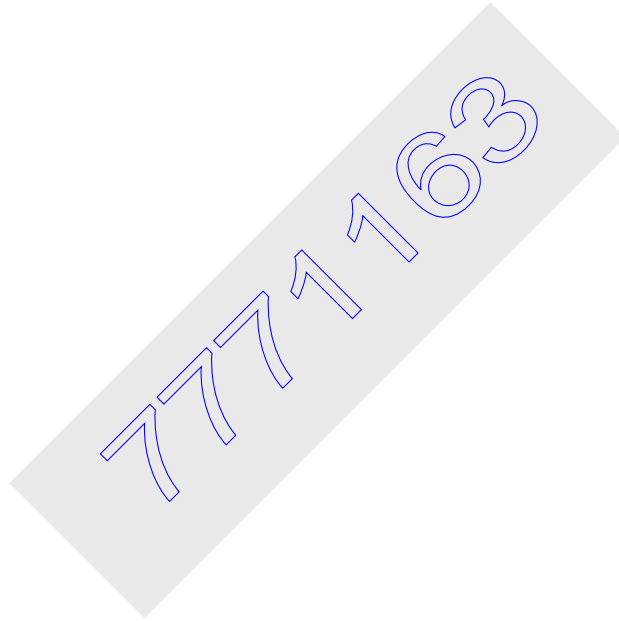

THIS PAGE INTENTIONALLY LEFT BLANK

777163

SECTION 6 MAINTENANCE CHECKLIST

INSPECTION AND MAINTENANCE CHECKLIST

See F2097 at the end of this section.

FIBERGLASS MAINTENANCE

See Bulletin W04-009 at the end of this section.

777163

THIS PAGE INTENTIONALLY LEFT BLANK

777163

ALPHABETICAL INDEX

Assembling, Disassembling, or Operating Crane Near Electric Power and Transmission Lines . . .	2-14
Accessing Parts	4-2
Accidents	2-15
Assembly and Disassembly Area	4-2
Assembly and Disassembly Notes	4-2
Auxiliary Load Drum Installation	4-33
Boom Disassembly Safety	2-19
Boom Ladder Assembly	4-37
Boom Rigging Guide	4-38
Change of Ownership Registration	1-1
Clamshell Reeving	4-76
Cold Weather Heater Package	3-65
Cold Weather Mast Operation	4-2
Continuous Innovation	2-1
Controls Identification and Function	3-11
Crane Access Points	2-4
Crane Assembly	4-7
Crane Data	1-1
Crane Disassembly	4-23
Crane Orientation	1-1
Crane Orientation	4-1
Crane Weights	1-5
Crane Weights	4-2
Crane/Attachment Identification	1-1
Diagnostic Display	3-50
Digital Display Readings	3-45
Disabling and Enabling Free Fall	3-40
Electrocution Hazard Devices	2-26
English and Metric Conversions	1-8
Environmental Protection	2-17
Fiberglass Maintenance	6-1
Fire Extinguishers	2-15
Front Window Operation	3-8
Fuses	3-38
General Safety	4-1
Getting On or Off Crane	2-4
Hydraulic System Controls	3-62
Identification and Location of Components	1-2
Inspection and Maintenance Checklist	6-1
Introduction	1-1
Jib Rigging Guide	4-53
Limit Devices	3-23
Load Block Tieback	4-79
Load Line Reeving	4-70
Lowerworks Lubrication at Assembly	4-2
Lubrication	5-1
Lubrication	5-1
Maintenance Checklist	6-1
Manitowoc Dealer	1-1
Multiple Crane Lifts	2-27
Multiple Load Line Operation	2-26
Nameplates and Decals	2-1
Operating Controls And Procedures	3-1

Operating Controls	3-8
Operating Controls	4-5
Operating Limitations	4-4
Operation	3-27
Operational Aids	2-12
Operator Manual/Capacity Chart Storage	2-6
Optional Attachments	4-1
Outline Dimensions	1-4
Pad Eye Usage for Wire Rope Reeving	4-68
Pedestal/Barge Mounted Cranes	2-21
Personal Fall-Protection	2-6
Personnel Handling Policy	2-20
Pile Driver Adapter	4-52
Pile Driving and Extracting	2-25
Preparation for Cold Weather	3-68
Preparing Crane For Operation	3-27
Pre-raising Checks	4-20
Programmable Controller Calibration Procedures	3-45
Refueling	2-15
Remote Controls	3-22
Remote Controls	3-43
Retaining Connecting Pins	4-2
Rigging Drawings	4-1
Safe Maintenance	2-16
Safe Operating Practices	2-7
Safety and Information Signs	2-3
Safety Devices	2-12
Safety Information	2-1
Safety Messages	2-1
Seat Controls	3-26
Self-Erecting Equipment	4-1
Set-up and Installation	4-1
Shipping Crane Components	4-5
Signals	2-11
Special Application/Service	2-20
Standard Hand Signals for Controlling Crane Operations	3-2
Swing Limiter Operation	3-57
Symbol Identification	3-4
Universal Anchor Joint	4-80
Voltmeter Operation	3-39
Wind Conditions	3-64
Wire Rope Installation	4-63

771163

