

GROVE[®]

GMK 4100

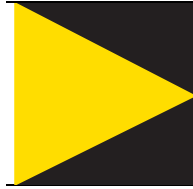

Operating instructions Part 1 – Driving

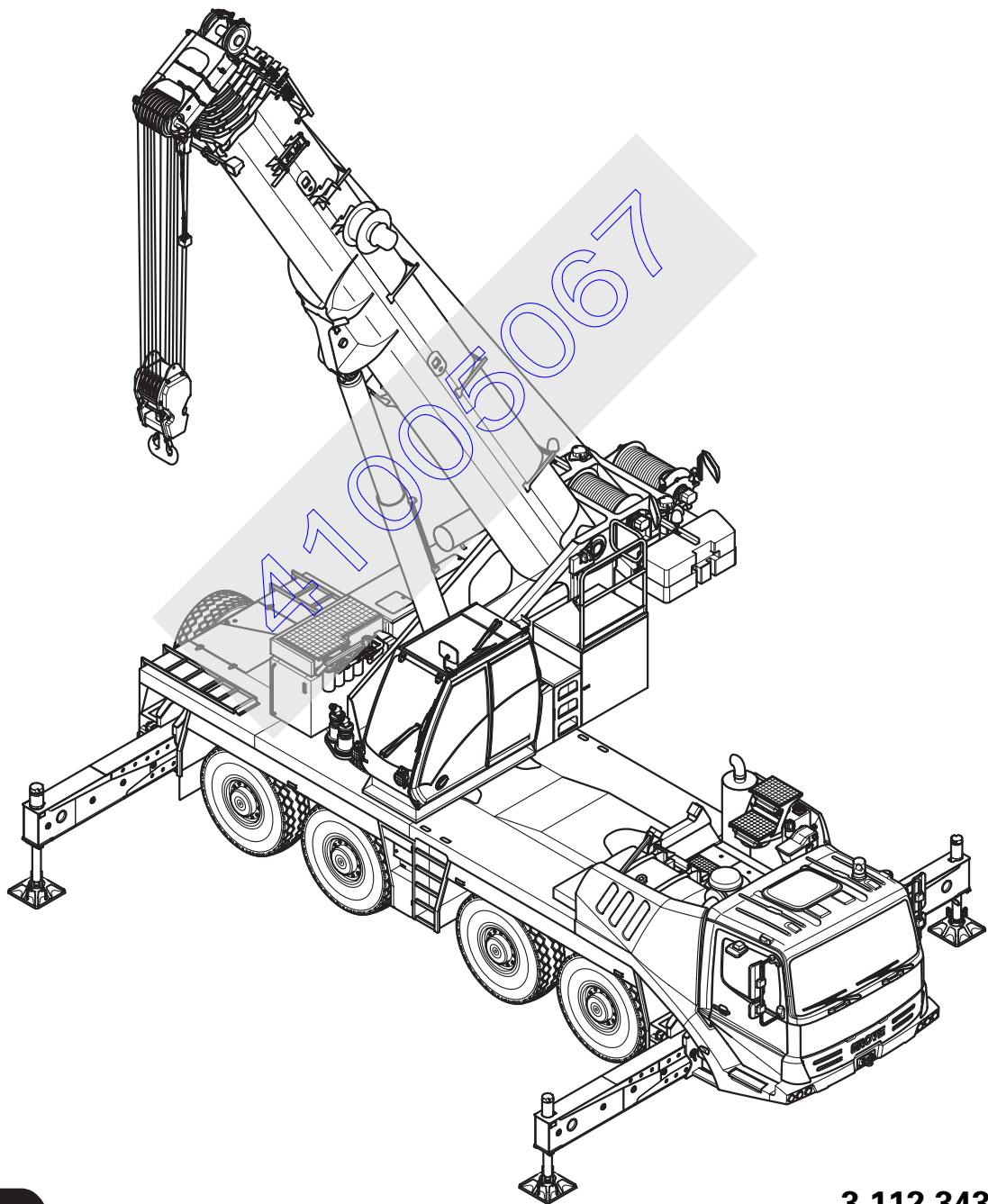

Manitowoc[®]
Crane Group

Serial number

3 112 343 en
23.11.2006

A **Manitowoc** Company

Important note

Any type of duplication or excerpt from this document, also in electronic form, are not subject to the revision service of **Manitowoc Crane Group Germany GmbH**.

41005067

© Copyright reserved by **Manitowoc Crane Group Germany GmbH**

Dissemination or duplication of this document as well as utilization and disclosure of its contents are prohibited unless expressly permitted. Infringement will incur liability for compensation. All rights pertaining to registration of patent or utility model are reserved.

23.11.2006

These operating instructions are divided into two parts:

Part 1 – Driving

Part 2 – Crane Operation

Contents, part 1:

- 1 Overview**
- 2 Basic safety instructions**
- 3 Operating elements for driving**
- 4 Starting / turning off the engine for driving**
- 5 Driving**
- 6 Driving modes**
- 7 Malfunctions in driving mode**
- 8 Technical information on the carrier**
- 9 Index**

You will find chapters 10 to 17 in part 2 – Crane Operation.

Blank page

41005067

1 Overview

1.1 Identification 1 - 1

1.2 EC Declaration of Conformity..... 1 - 5

1.3 Documentation supplied..... 1 - 6

1.4 Information about the operating instructions 1 - 7

1.4.1 What do the symbols used mean? 1 - 7

1.4.2 How are the operating instructions structured? 1 - 9

1.4.3 How do I find the information I need? 1 - 11

1.4.4 What information is available for operations planning? 1 - 14

1.5 Conversion table for US measurements..... 1 - 15



41005067

1

Overview

1.1

Identification

These operating instructions are intended only for the truck crane with the serial number specified on the front cover.



41005067

Overview
1.1 Identification

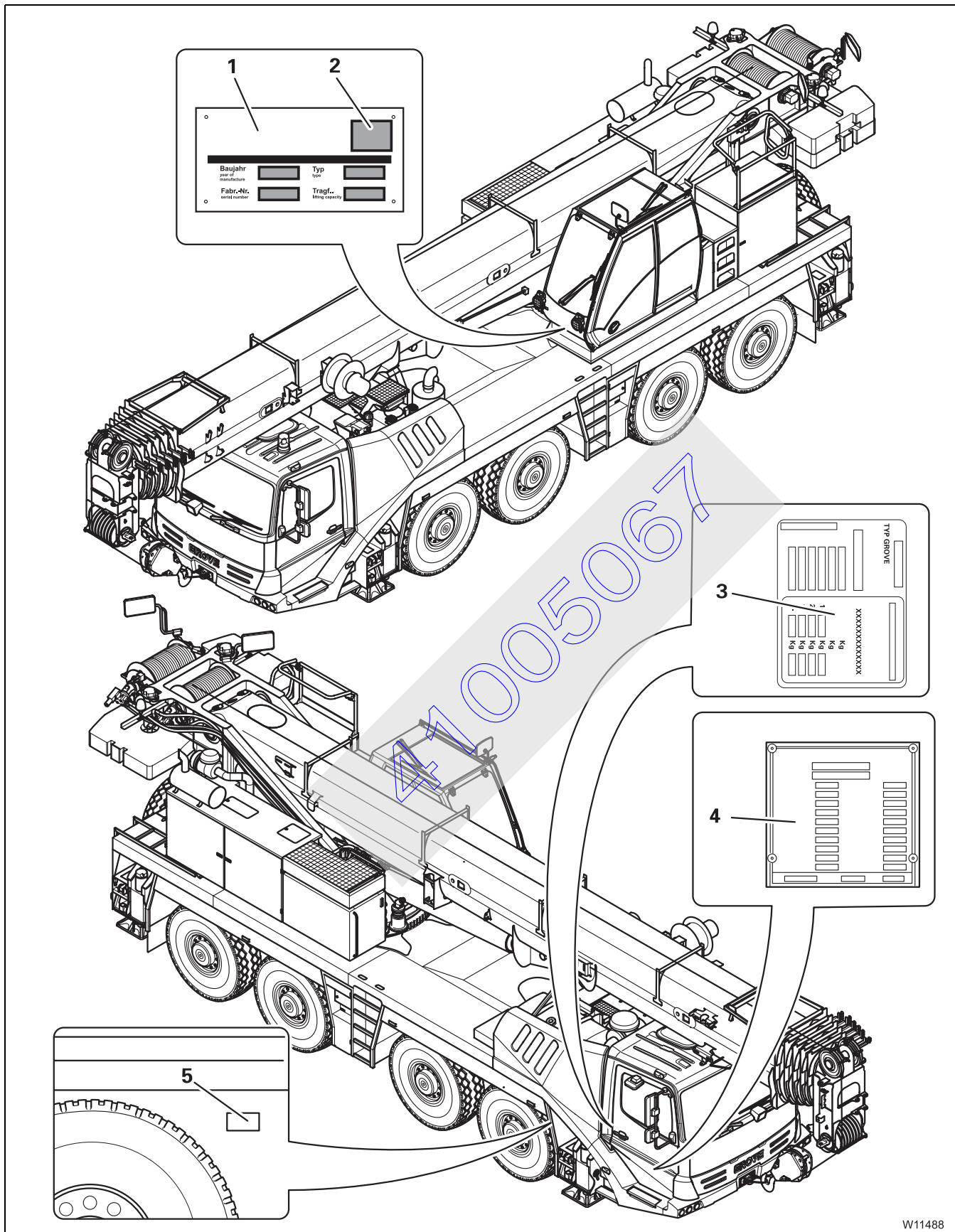

23.11.2006

The following plates and numbers are attached to the truck crane for identification purposes:

- 1** Serial number and crane type
- 2** The CE mark, only with truck cranes that are delivered to member countries of the EU
- 3** The serial number of the driver's cab
- 4** The chassis number and crane type
- 5** The chassis number in front of the first axle line in the frame

The location of the identification numbers on removable rigging parts (e.g. counterweights, lattice extension) is described in the corresponding chapters or in the specific operating instructions supplied.

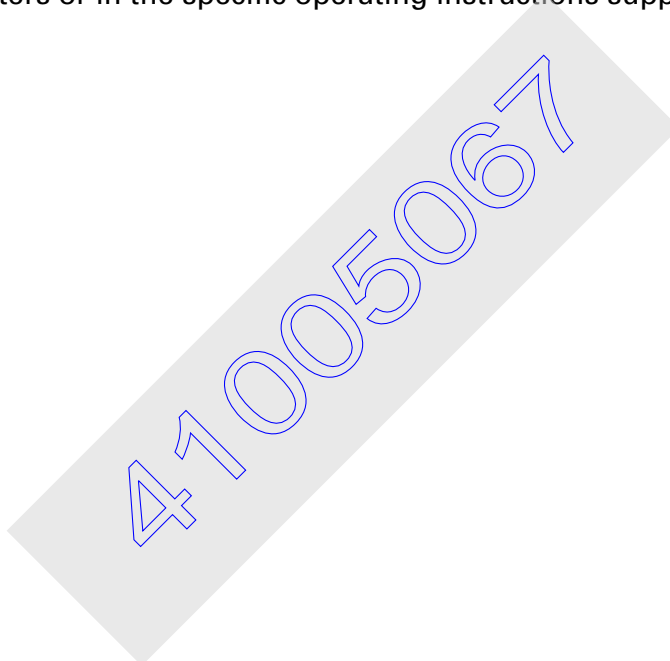

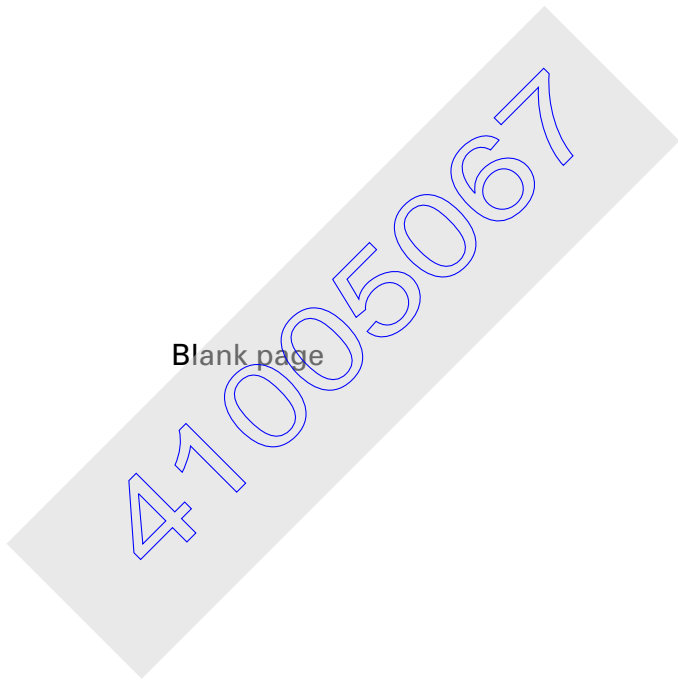



1.2

EC Declaration of Conformity

Operators of truck cranes which are delivered to EU member countries receive a declaration of conformity as a supplement to the delivery protocol. An example of the declaration of conformity is illustrated below.

EC-Konformitätserklärung

Ich bestätige hiermit, dass die nachfolgend benannte Maschine aufgrund ihrer Konfiguration und Bauweise in der von mir in Verkehr gebrachten Ausführung den einschlägigen grundlegenden Sicherheits- und Gesundheitsanforderungen der nachfolgenden EU-Richtlinien entspricht. Bei einer nicht ordnungsgemäßen Führung der Maschine verliert diese Erklärung ihre Gültigkeit.

- 1) Maschinenrichtlinie 2006/42/EG und Anhänge
- 2) Elektromagnetische Verträglichkeits-Richtlinie 2004/108/EG und Anhänge
- 3) Geräuschrichtlinie 2005/24/EG (Bewertungsverfahren nach Anhang VI)

Beschreibung der Maschine	Modellname
Hersteller:	Deutsche Grove GmbH
Typ	GMK 4100
Fabrik-Nr.:	42000001
Fabrigser-Nr.:	10000000000000000000
Reihe:	4100
Motorart:	CEC 10000000000000000000
Geometrische Schutzart:	NA 10000000000000000000
Geometrischer Schutzgrad:	NA 10000000000000000000
Angeordnete Normen:	EN 12002-1, EN 12002-2, EN 12002-3, EN 12002-4
Angeordnete Normen:	EN 12002-1, EN 12002-2, EN 12002-3, EN 12002-4
Angeordnete Normen:	EN 12002-1, EN 12002-2, EN 12002-3, EN 12002-4
Bezeichnung des Herstellers:	in Vertretung der Firma Grob u. Vorschütz, 80774, 80774, 80774
Bezeichnung des Herstellers:	EN 12002-1-1, EN 12002-1-2, EN 12002-1-3
Bezeichnung des Herstellers:	Waldschütz,

CE

Hersteller-Verantwortlich:	Leiter Technik	Geometrischer Schutz
Angaben zum Unternehmen:	Geometrischer Schutz	Leiter Konstruktion



Funktionserklärung

- Ausführung in Grob- oder Maschinenmodell
- Ausführung des Vertriebsmodells
- Funktionserklärung des Maschinenmodells

- Original für Deutsche GMK 4100-Joch
- Original für Grob

CE-Konformitätserklärung GMK 4100

Bezeichnung des Herstellers: TÜV Thüringen, Industriestraße 11, 98520, Burgkranz, Thüringen, DE 98520
Am 10.11.2006, 10:00 Uhr, Germany
Typ: Funkwellen-Emissionen und -Immunität

Ich bestätige hiermit, dass die nachfolgend benannte Maschine aufgrund ihrer Konfiguration und Bauweise in der von mir in Verkehr gebrachten Ausführung den einschlägigen grundlegenden Sicherheits- und Gesundheitsanforderungen der nachfolgenden EU-Richtlinien entspricht. Bei einer nicht ordnungsgemäßen Führung der Maschine verliert diese Erklärung ihre Gültigkeit.

W12258

1.3**Documentation supplied**

The precise number of documents supplied depends on the scope of equipment of the truck crane. The following documents are included in delivery:

– Operating instructions

Contain information on driving and crane operation.

– Lattice extension operating instructions

Are only supplied when the truck crane is equipped with a lattice extension or other parts for extending the main boom (e.g. auxiliary single-sheave boom top and heavy load lattice extension).

– Operating instructions for additional equipment

These are only supplied when the truck crane is supplied with additional equipment which is not described in the operating instructions for driving and crane operation.

– Documents from other manufacturers

Original documentation for parts which are not manufactured by *Manitowoc Crane Group Germany GmbH* in Germany, such as the engine and central lubrication system, as well as the tachograph, auxiliary heaters, radio and, when appropriate, other additional equipment.

– Maintenance manual

Contains information on maintenance work alone, and contains no instructions for repair work.

– Safety manual

Provides information on the safe operation of the truck crane.

– Circuit diagrams

Circuit diagrams for the electrical system, hydraulic system and pneumatic system are supplied.

– Lifting capacity table

Information on the lifting capacity when the truck crane is in different rigging modes.

– **Outrigger pressure table**

Information on the outrigger pressure when the truck crane is in different rigging modes.

– **Spare parts list and list with the standard and traded parts**

For the procurement of spare parts. Information about the position and quantity of the plating.

1.4

Information about the operating instructions

These operating instructions are not a training manual for prospective crane operators. All descriptions have been written explicitly for crane operators who have been trained to operate truck cranes.

These operating instructions are designed as a reference manual. They provide either a brief or a detailed explanation to the crane driver, based on their prior knowledge, of the individual operating steps and procedures.

1.4.1

What do the symbols used mean?

The following definitions and symbols are used in the operating instructions and in the maintenance instructions to highlight particularly important information.

The vertical line to the left of the warning text indicates that this text, regardless of its length, relates to the warning symbol.



This symbol indicates hazards related to the described operation that may cause personal injury. The type of danger (e.g. danger to life, risk of injury or danger of being crushed) usually precedes the warning.





This symbol indicates dangers which put objects at risk, e.g. damage to the truck crane or other parts which are located within the working range.



This symbol warns you about situations where there is a danger of electrocution.



This symbol reminds you that you are working with substances which pose a risk to the environment. Take particular care. For further information on handling substances that are harmful to the environment;  *Maintenance manual*, chapter on *Safety and environmental protection*.



The hand with the pointing finger indicates passages that contain additional instructions and tips regarding truck crane operation.



This symbol indicates that the topic is continued on the next page. Turn to the next page.

Horizontal lines always indicate the start or the end of an example. The text used for examples is in a different font.

41005067

1.4.2

How are the operating instructions structured?

Division

The operating instructions are divided into two parts.

- **Part 1** with chapters **1** to **9** contains a description of how to drive the truck crane.
- **Part 2** with chapters **10** to **17** contains a description of the crane operation.

One part on its own does not constitute a complete set of operating instructions; both parts must be included with the truck crane.

The basic safety instructions, also for crane operation, are included in **chapter 2** only. Please read these safety instructions and observe them.

Structure of the chapters

Chapters **3** and **10** are structured in relation to the product, and give an overview of all operating elements on the truck crane. You will find cross-references to the related brief descriptions, and from there, to further chapters.

Chapters **4** to **7** and **11** to **15** describe procedures, and are therefore structured in relation to these operations. For more extensive processes, the description is given with **checklists** and **operation instructions**.

- The checklists show the procedure in the required sequence, e.g. for rigging work. From there, cross-references take you to the corresponding operation descriptions.
- The operation descriptions describe the work in detail, including the required **warnings and safety instructions**.

You are obliged to read these sections before using the truck crane for the first time and if you are still unsure about how to operate the truck crane.



Risk of accidents when only referring to the checklists during operation

The checklists and operating instructions should always be regarded as a single unit for the complete description of a rigging procedure.

It is only safe to operate the truck crane by referring to the checklists when you are familiar with all the dangers which may occur, and are confident in completing the necessary steps as described in the relevant operation instructions.

If in doubt, always read the section first which is referred to in the checklist.



Structure of the pages

Each page of the operating instructions is divided into a wide text column and a narrow column.

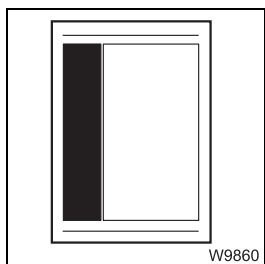

The **narrow column** contains various pieces of information:

- Chapter and section numbers
- Headings of the subsections
- Information and warning symbols
- Images with individual operating elements with parts of the truck crane or with pictograms

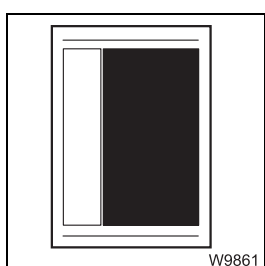

Different methods of emphasis are used in the **text column**:

- When a section is preceded by a hyphen (as in this section, for example) you will find a list.
- When a section is preceded by a bullet, you will be required to take concrete action, e.g.
 - Select neutral on the transmission.
- *Italics* are used to highlight the following type of text passages:
 - Designations of operating elements and switching states, such as *automatic* or *manual*.
 - Headings of sections to which a reference is made.
 - The names of other documents to which a reference is made.

1.4.3

How do I find the information I need?

The operating instructions contain the following guides for orientation.

- The **Contents** at the front in sections 1 and 2 list all the chapters in the section.
- The **Table of contents** before each chapter provides an overview of the topics it contains.
- The **Index** in chapters 9 and 17 gives an alphabetic list of keywords and search terms with a reference to the relevant page in the operating instructions.
- Cross-references are labelled with an arrow (▬▶) and refer to other pages in the operating instructions. These pages contain more detailed information, or information that relates to the topic in question. Furthermore, you can use the cross-references to systematically familiarise yourself with specific information on the truck crane or look up functions of individual elements.

The following pages give an example of how to use the cross-references.



41005067

**Cross-references
example**

The illustrations and texts in this section are only an example and may differ from the conditions on your truck crane.

A

1 ⇒ S. 4 - 4

4-2

B

2 ⇒ S. 4 - 37

4-4

C

1

2

3

4

⇒ S. 6 - 82

4-37

D

6-82

W9571

The parking brake is used as an example to show how the cross-references guide you through the operating instructions.

- A** In this example, the general overview is shown on page 4 - 2. The driver's cab is labelled as number **1**. The related table contains a cross-reference in the form
- 1 Driver's cab** ▣▣▣▣▶ p. 4 - 4
- B** Page 4 - 4 shows a top view of the driver's cab. The parking brake is labelled as number **2**. The related table contains a cross-reference in the form
- 2 Parking brake** ▣▣▣▣▶ p. 4 - 37
- C** Page 4 - 37 gives a brief description of all the functions of the parking brake. If further information is available, the brief description contains a cross-reference, e.g.
- 4 Test position for towing a trailer:** – Pull the lever back until it locks into place
– Press in the lever and pull it further backwards
The parking brake for the trailer is released;
▣▣▣▣▶ p. 6 - 82.
- D** Follow the cross-reference to page 6 - 82. Here, the test position of the parking brake when towing a trailer is described in detail, with all the preliminary requirements and safety instructions.
- There may be additional cross-references here, such as to related pages in the chapter *Malfunctions*.
-

1.4.4

What information is available for operations planning?

Extensive information is required for operations planning in order to guarantee safe, smooth and efficient operation of the truck crane:

The operating instructions contain

- Measurements and weights of the truck crane; ■■■▶ p. 8 - 2, ■■■▶ p. 16 - 2,
- Driving modes permitted on public roads; ■■■▶ p. 6 - 3,
- Dimensions and weights of equipment that can be removed; ■■■▶ p. 8 - 4, ■■■▶ p. 16 - 2,
- Turning circle radii; ■■■▶ p. 8 - 7,
- The permitted outrigger spans; ■■■▶ p. 13 - 28,
- The size of the outrigger pads; ■■■▶ p. 8 - 6.

41005067

1.5**Conversion table for US measurements**

The following conversion factors will help you convert from metric to US units and vice versa when the truck crane is being used in countries that use US units of measurement.

Converting from	to	Multiply by
mm	to	0.03937
to	mm	25.4
m	ft	3.28084
ft	m	0.30479
m ²	ft ²	10.76391
cm ²	in ²	0.155
cm ³	in ³	0.061
l	gal (US)	0.264178
kg	lbs	2.204622
lbs	kg	0.45359
t	lbs	2204.622
lbs	t	0.0004536
kN	lbf	224.809
daN / cm ²	lbf / in ²	14.50378
lbf / in ²	daN / cm ²	0.06895
bar	psi	14.50378
psi	bar	0.06895
m/s	ft / s	3.28084
km/h or km	mph or mi	0.62137
mph or mi	km/h or km	1.60935
Nm	lbf ft	0.7375
°C	°F	1.8 x °C + 32
°F	°C	(°F-32) / 1.8
t / m ²	lbs / ft ²	204,8
m ² / t	ft ² / lbs	0,04882

Blank page

41005067

2 Basic safety instructions

2.1	Intended use	2 - 1
2.1.1	Improper use	2 - 2
2.2	Organisational measures	2 - 3
2.3	Qualifications of the personnel	2 - 5
2.4	Safety instructions for driving the truck crane.	2 - 6
2.5	Safety instructions for crane operation.	2 - 7

41005067

41005067

2

Basic safety instructions



Information on the warnings used;  *What do the symbols used mean?*, p. 1 - 7.

2.1

Intended use

The GMK 4100 is a state-of-the-art truck crane, designed in accordance with approved safety regulations. Nevertheless, the operator or third parties can still be endangered and the crane or other property put at risk while using it.

Modifications may only be made to the truck crane following the approval of **Manitowoc Crane Group Germany GmbH**.

The GMK 4100 truck crane may only be used in a perfect technical condition as intended and with due attention paid to safe operation and possible hazards.

Any malfunctions that could impair safety must be eliminated immediately.

The GMK 4100 truck crane may only be operated without the corresponding special equipment within the permitted temperature range;  *Technical information on the carrier*, p. 8 - 1.

The GMK 4100 truck crane is designed solely for lifting loads which are within the permitted GMK 4100 lifting capacities. The load must be slung as prescribed to a hook block which is positioned vertically over the load prior to lifting.

Intended use also includes

- Observing the entire crane documentation, consisting of the operating instructions, the lifting capacity table, the outrigger pressure table and the safety manual
- Adhering to the inspection and maintenance requirements specified in the maintenance manual



The GMK 4100 may only be operated with parts of equipment which are permitted by **Manitowoc Crane Group Germany GmbH**, and which are labelled with the serial number of the GMK 4100.

The manufacturer is not liable for any damage caused by improper or unauthorized use of the GMK 4100 truck crane. The user alone bears the risk.

2.1.1

Improper use

Manitowoc Crane Group Germany GmbH is not liable for any damage caused by improper or unauthorized use of the GMK 4100 truck crane. The user alone bears the risk.

Improper use includes:

- Transporting loads on the carrier
- Pushing, pulling or lifting loads with the level adjustment system, supports or outrigger cylinders
- Pushing or pulling loads or lifting them off the ground using the slewing gear, derricking gear or telescoping mechanism
- Pulling off fixed objects with the crane
- Two-hook operation with the boom extension and two-hook operation on the main boom head without additional equipment
- Setting SLI codes that do not correspond to the actual rigging mode
- Working with an overridden SLI or overridden lifting limit switch
- After SLI shutdown, increasing the working radius by pulling the raised load at an angle (e.g. with a chain hoist)
- Misuse of the outrigger pressure indicator as a safety function to prevent the crane from overturning (outrigger pressure higher than 0 t)
- On-road driving in impermissible driving mode (axle load, dimension)
- Moving the rigged crane in an impermissible driving mode
- Using equipment that is not permitted for the crane
- Transporting people in any way with the lifting tackle, on the load, or in the crane cab while driving
- Transporting passengers outside the driver's cab
- Loading and unloading work, i.e. continuous operation without a sufficiently long break
- Usage for any kind of sport or recreational activities, especially for “bungee” jumping

2.2

Organisational measures

The operating instructions and the lifting capacity table should be kept in the truck crane for immediate access at all times, and must not be removed from the truck crane. You must have read and understood the operation and safety instructions in these operating instructions and comply with them when working.

In addition to the operating instructions and the lifting capacity table, observe all general, statutory and otherwise applicable regulations concerning accident prevention and environmental protection. You must read and understand them, and observe them when operating the crane and driving.

They could include:

- How to deal with hazardous materials
- Wearing personal protective equipment
- Traffic regulations
- All applicable regulations concerning the operation of a crane

Make sure that persons who will work on the truck crane are provided with the required information prior to commencing work. Instruct your personnel (e.g. banksmen, slingers, rigging personnel) accordingly.

Make sure the maintenance personnel have the necessary expertise to operate the crane safely. Make sure the maintenance personnel have access to the operating instructions.

Only qualified or instructed personnel may carry out work on the truck crane.

The responsibilities regarding the operation of the crane, rigging, maintenance and repair work must be clearly defined.

Make sure only authorised personnel carry out work on the truck crane.

Do not leave long hair open or wear loose clothing or jewellery (including rings) during work. These could get caught or pulled into the unit and result in injury.

Use your personal protective gear whenever necessary or prescribed.

Observe all safety instructions and warnings on the truck crane.

Keep all safety instructions and warnings on the truck crane in a legible condition.



Observe the operational organisation on the site. Report your arrival to the site management. Ask for the personnel authorised to instruct you.

Find out where the fire extinguishers are and how to operate them at every site.

Note the fire alarm and fire fighting facilities.

Should the operating behaviour of the truck crane change in such a manner that safety is impaired or if you are in doubt about the operational safety of the truck crane, stop the truck crane immediately and inform the responsible departments or persons.

Do not make any changes to the programmable control systems (e.g. the SLI).

Do not modify or retrofit the truck crane without the consent of the manufacturer, if such changes would affect the safety. This also applies to

- The installation of safety devices
- The adjustment of safety devices and valves

All welding work (especially on load carrying members) may only be performed by qualified professional personnel with the prior permission of **Manitowoc Crane Group Germany GmbH**.

To avoid damage, especially to electronic parts, there are certain steps you must take before doing any welding work. You should therefore always consult **CraneCARE** before any welding work.

Make sure both the prescribed intervals and the intervals specified in the operating and maintenance instructions for periodic inspections, tests and maintenance work are adhered to.

Replace the hydraulic hose lines, or have them replaced, at the prescribed intervals, even if no safety defects are noticeable.

Spare parts must fulfil the technical requirements defined by the manufacturer. Genuine spare parts always meet these requirements.

Appropriate servicing equipment is absolutely necessary in order to carry out maintenance work.

Observe the national regulations that apply to transport when loading the truck crane. Also observe the prescribed safety measures of the carrying agent or railway company.

Monitor the work of personnel, at least occasionally, and make sure they work in accordance with the operating instructions in a safe and conscientious manner.

2.3

Qualifications of the personnel

These operating instructions are not a training manual for prospective crane operators.

All descriptions are written explicitly for crane operators who have been trained to operate truck cranes.

Personnel in training may only operate the truck crane under supervision.

Only reliable personnel may operate or carry out work on the truck crane.

As crane operator you must fulfil a number of requirements:

- You must possess a driving licence for this type of vehicle that is valid in the country in which you are working
- You must have general knowledge about working with cranes and the qualifications required in the country in which you are working
- You must be familiar with and understand the operating instructions
- You must be familiar with and have understood the accident prevention regulations
- You must fulfil all physical and mental requirements for truck crane operation, e.g. perfect sight and hearing and the ability to react quickly

Please also refer to the section in the *Safety manual* titled *You as driver and crane operator*.

Only experienced personnel who are familiar with the valid accident prevention regulations are authorised to sling loads and instruct the crane operator.

Your responsibilities as a crane operator (including those concerning traffic regulations) must be clearly defined. You must be in a position to refuse instructions given to you by third parties that violate the safety regulations.

Only trained personnel with special knowledge and experience in the fields of hydraulics, pneumatics and electrical equipment and electronics may carry out maintenance work on the truck crane.

Manitowoc Crane Group Germany GmbH conducts general and type-related crane operator courses and technical courses.

2.4

Safety instructions for driving the truck crane

Walk around and inspect the truck crane before you start the vehicle. Check the condition of the truck crane carefully using the checklists in the operating instructions. Do not assume everything is in working order simply because it was in working order at the end of the last shift.

Check that all covers and safety devices are fitted properly and that they are in good condition before starting the vehicle.

Use the appropriate access aids when checking overhead crane parts. Do not use parts of the crane as access aids.

Keep all handles, steps, step treads and ladders free of dirt, snow and ice.

Check all operating and control elements in the driver's cab before starting the engine.

After starting the engine, take note of all the lights and control elements.

After driving, secure the truck crane against unauthorized use.

41005067

2.5

Safety instructions for crane operation

Carefully select a safe site for the truck crane from where you can work safely.

Walk around the truck crane and inspect it before beginning crane operation. Check the condition of the truck crane carefully using the checklists in the operating instructions. Do not assume everything is in working order simply because it was in working order at the end of the last shift.

Check daily that all covers and safety devices are fitted properly and are in good condition before crane operation.

Check the safety devices (SLI, lifting limit switch, dead man's switch, emergency stop switches) every day before you start work.

Use the appropriate access aids when carrying out overhead rigging or maintenance work. Do not use parts of the crane as access aids.

Walk only on those parts of the truck crane which are equipped with appropriate steps and railings and therefore guarantee safety.

Always use a ladder for work above head height.

Keep all handles, steps, step treads and ladders free of dirt, snow and ice.

Check all operating and control elements in the crane cab before starting the engine.

After starting the engine, take note of all the lights and control elements.

Make sure that there are no unauthorized people in the vicinity of or on the truck crane when rigging or during crane operation. Cordon off the danger zone clearly and mark the zone as such.

When lifting a load, raise the boom to balance out the increase in radius caused by the boom bending so that the load is lifted up vertically and does not drag, injure helpers or fall into the hoist rope diagonally (e.g. from a vehicle or scaffolding). Inform any banksmen and helpers about this issue as well.

Support the truck crane with the outrigger span required for the currently rigged counterweight before turning the superstructure.



Always level the truck crane before operating the crane.

Only use parts of equipment (counterweight sections, lattice extension) that belong to your truck crane. Both the truck crane and the equipment must have the same serial number.

Lifting loads simultaneously with two cranes is particularly dangerous. Carry out this type of work with special care.

Set the load down whenever you interrupt work, and never leave the truck crane as long as a load is raised.

Secure the truck crane against unauthorised use whenever you leave it.

Crane operation carried out in the vicinity of live electrical cables as well as oil, gas or other supply lines is dangerous and requires that special precautionary measures be taken. Please observe the instructions in the section titled *Crane operation under special operating conditions* in the *Safety manual* and the respective national regulations.

41005067

3 Operating elements for driving

3.1	Overview of the operating elements	3 - 1
3.1.1	On the outside of the truck crane	3 - 2
3.1.2	Driver's cab	3 - 4
3.1.3	Instrument panel	3 - 7
3.1.4	Display, driver's cab	3 - 10
3.1.5	Steering column / steering wheel	3 - 11
3.1.6	Transmission operating elements	3 - 12
3.1.7	Tachograph	3 - 13
3.1.8	ECOS control unit	3 - 14
3.1.9	ECOS display – main menu	3 - 16
3.1.10	ECOS display – submenus	3 - 18
3.1.11	Heating / Air-conditioning system	3 - 24
3.1.12	Sockets for hand-held control	3 - 26
3.1.13	Outrigger control units	3 - 27
3.2	Short description of the operating elements	3 - 29
3.2.1	Definition of positional references	3 - 29
3.2.2	General information on the operating elements	3 - 30
3.2.3	General rules for buttons and symbols on the display	3 - 31
3.2.4	Engine	3 - 32
3.2.5	Electrical system	3 - 34
3.2.6	ECOS crane control	3 - 34
3.2.7	Transmission	3 - 37
3.2.8	Transfer case	3 - 41
3.2.9	Final drive	3 - 42
3.2.10	Brakes	3 - 43
3.2.11	Steering / separate steering	3 - 46
3.2.12	Suspension	3 - 47
3.2.13	Lighting / windscreen wipers / horn	3 - 48
3.2.14	Level adjustment system	3 - 50
3.2.15	Tachograph / speedometer	3 - 52
3.2.16	Diagnostics	3 - 53
3.2.17	On-board computer	3 - 54
3.2.18	Push-up roof	3 - 56
3.2.19	Windows, doors, keys	3 - 56
3.2.20	Front flap	3 - 58
3.2.21	Storage compartment	3 - 58

41005067

3

Operating elements for driving

All operating elements for crane operation are described in chapter 10.

3.1

Overview of the operating elements

This section shows the position and designation of the operating elements for driving. This also includes display elements such as lights or displays.



Operating elements which are only available with additional equipment are designated accordingly. These designations are made in this section only and are not repeated in the following sections.

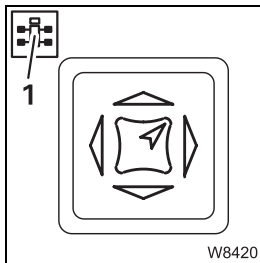

Some figures show details from a different perspective than the total view. The perspective is indicated by the symbol (1).

41005067

3.1.1 On the outside of the truck crane

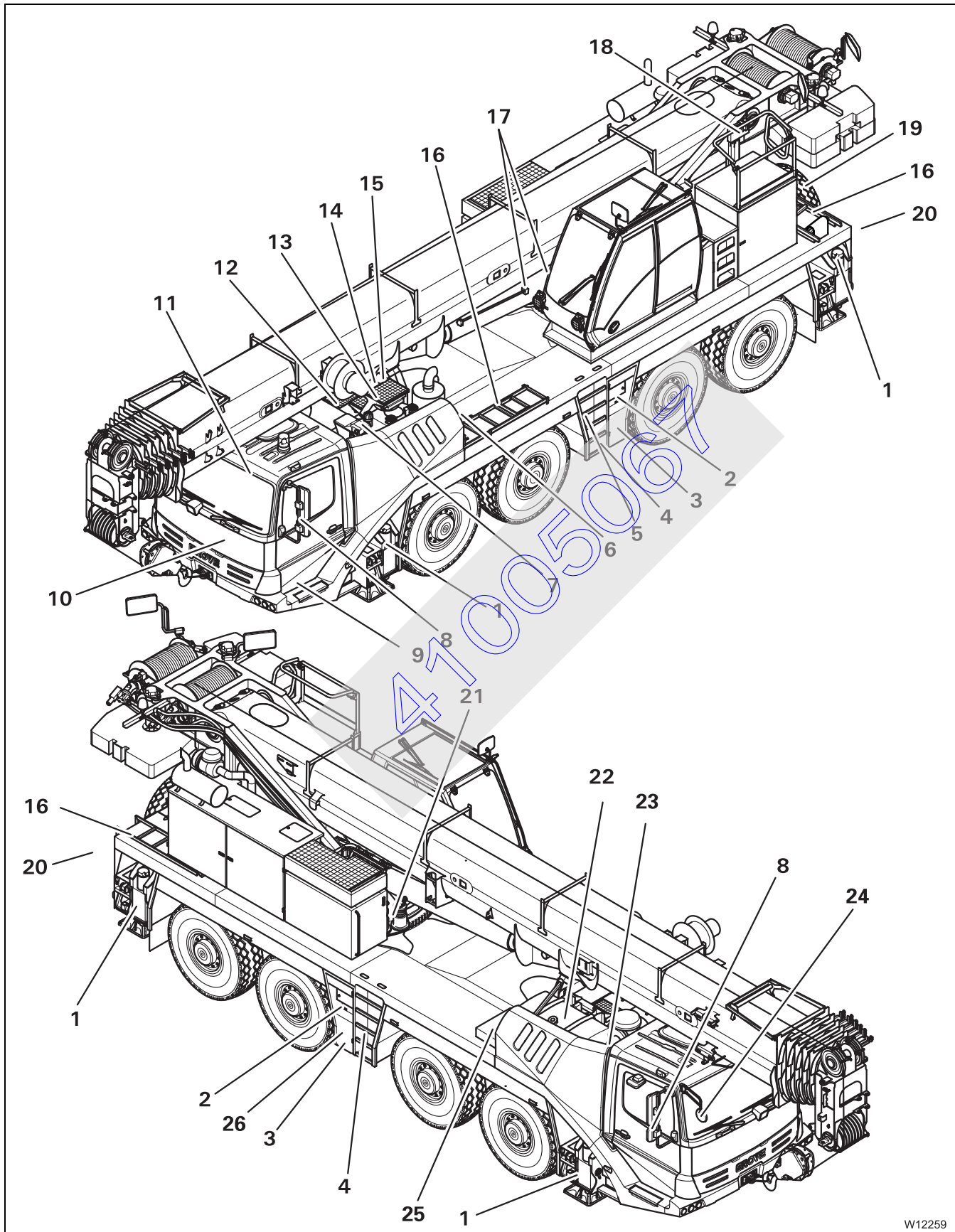

W12259

23.11.2006

1	Outriggers, operation	▣▣▣▣ p. 13 - 25
	Lighting, outriggers	▣▣▣▣ p. 3 - 49
2	Sockets for hand-held control	▣▣▣▣ p. 3 - 26
	Outrigger control units ¹⁾	▣▣▣▣ p. 3 - 27
	Emergency stop switch	▣▣▣▣ p. 4 - 22
3	Storage compartment	▣▣▣▣ p. 3 - 58
4	Filler connection for the compressed air system	▣▣▣▣ p. 7 - 6
	Tyre inflator connection	▣▣▣▣ p. 7 - 15
5	Access ladders	▣▣▣▣ p. 4 - 5
6	Hydraulic oil tank, inspection glass ²⁾	
7	Coolant reservoir, engine ²⁾	
8	Adjusting the mirrors	▣▣▣▣ p. 5 - 7
9	Tank Windscreen washing system	▣▣▣▣ p. 5 - 6
10	Front flap	▣▣▣▣ p. 3 - 58
11	Driver's cab	▣▣▣▣ p. 3 - 4
12	Engine for driving	▣▣▣▣ p. 4 - 1
13	Hydraulic oil cooler, second cooler ¹⁾	
14	Oil dipstick / filler neck, engine ²⁾	
15	Valves on hydraulic tank	▣▣▣▣ p. 4 - 8
16	Ladders	▣▣▣▣ p. 4 - 5
17	Switching on boom floating position	▣▣▣▣ p. 6 - 9
	Switching on boom pre-tensioning	▣▣▣▣ p. 6 - 10
18	Hydraulic emergency operation	▣▣▣▣ p. 15 - 57
19	Spare wheel ¹⁾	▣▣▣▣ p. 8 - 4
20	Wheel chocks	▣▣▣▣ p. 5 - 58
21	Switching on the slewing gear freewheel	▣▣▣▣ p. 6 - 8
22	Fuel tank	▣▣▣▣ p. 4 - 7
23	Air intake inhibitor ¹⁾	▣▣▣▣ p. 4 - 23
24	Adjusting the mirrors ¹⁾	▣▣▣▣ p. 5 - 7
25	Battery master switch	▣▣▣▣ p. 4 - 8
26	Central lubrication ²⁾	

¹⁾ Additional equipment

²⁾ ▣▣▣▣ *Maintenance manual*

3.1.2 Driver's cab

Overview

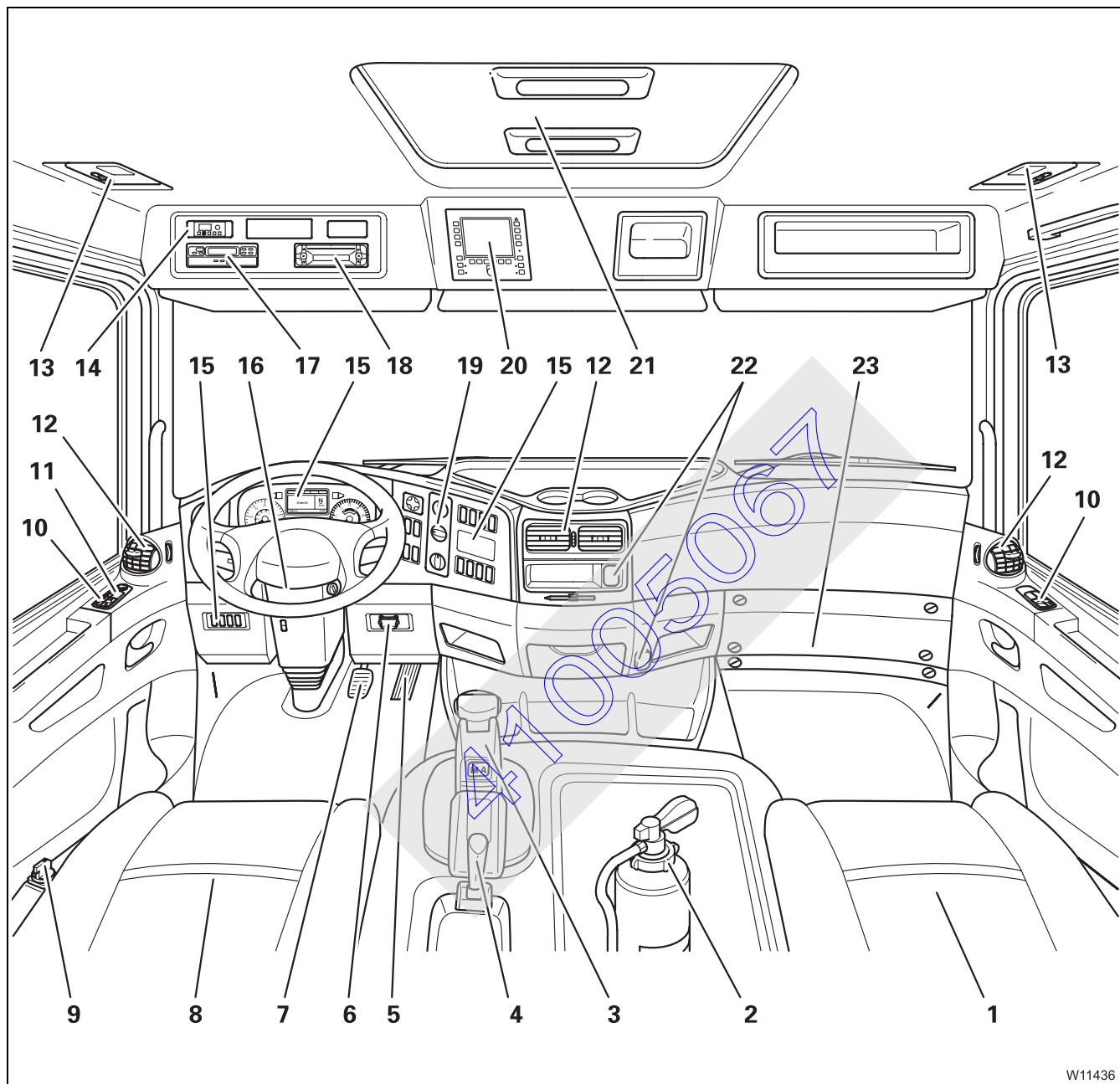

W11436

1	Passenger's seat	➡ p. 5 - 12
2	Fire extinguisher³⁾	
3	Transmission operating elements	➡ p. 3 - 12
4	Parking brake	➡ p. 3 - 44
5	Accelerator	➡ p. 5 - 47
6	Diagnostics	➡ p. 3 - 53
7	Service brake	➡ p. 5 - 37
8	Driver's seat	➡ p. 5 - 11
9	Separate steering	➡ p. 3 - 46
10	Window winder	➡ p. 3 - 56
11	– Adjusting the mirrors	➡ p. 5 - 7
	– Mirror heating	➡ p. 5 - 7
12	Air vent	➡ p. 5 - 76
13	Cab lighting	➡ p. 3 - 50
14	Auxiliary heater¹⁾	➡ p. 3 - 25
15	Instrument panel	➡ p. 3 - 7
16	Steering column / steering wheel	➡ p. 3 - 11
17	Tachograph or cover	➡ p. 3 - 13
18	Radio / cassette / CD^{1), 2)}	
19	Heating / Air-conditioning system	➡ p. 3 - 24
20	ECOS control unit	➡ p. 3 - 14
21	Push-up roof	➡ p. 3 - 56
22	Sockets 12 V / 24 V	➡ p. 3 - 34
23	Behind the cover	➡ p. 3 - 6

¹⁾ Additional equipment

²⁾ ➡ *Separate operating instructions*

³⁾ ➡ *Maintenance manual*



Behind the cover

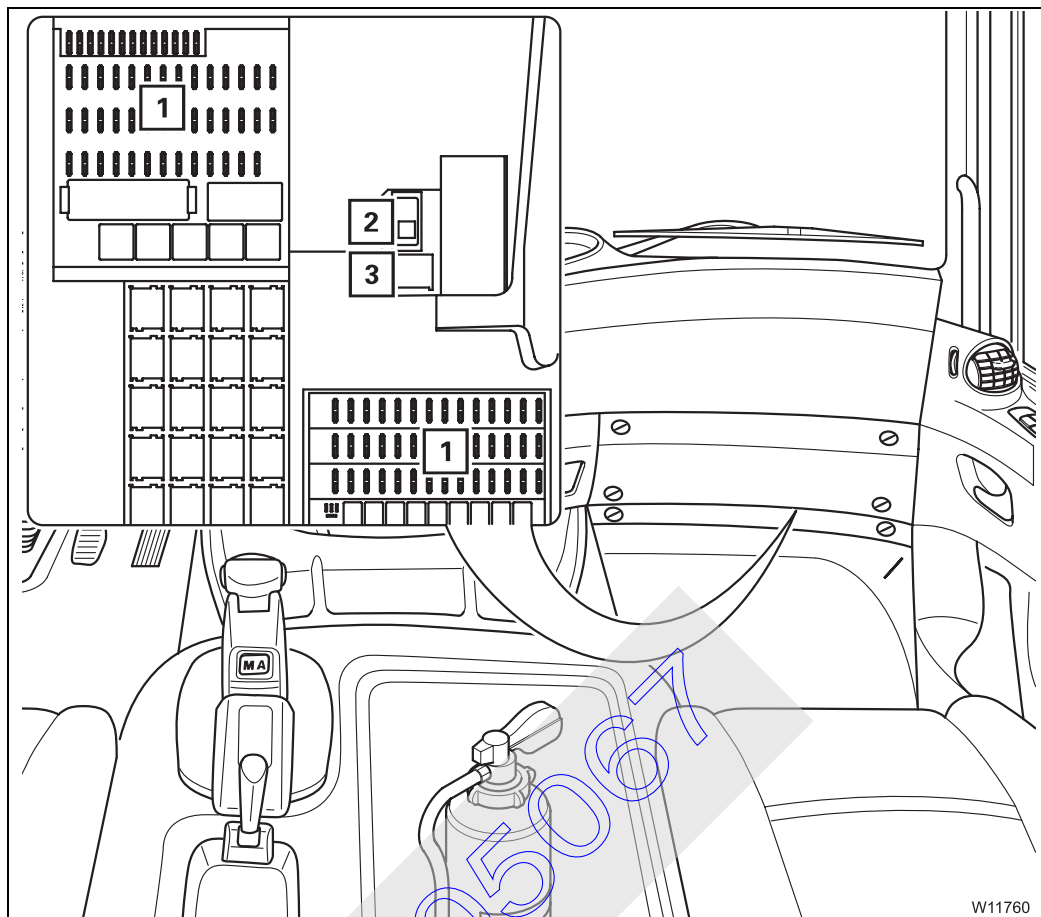

1 Fuses

▣▣▣▣ p. 7 - 17

2 Hydraulic emergency operation on / off¹⁾

▣▣▣▣ p. 15 - 57

3 Diagnostics

▣▣▣▣ p. 3 - 53

¹⁾ Additional equipment

3.1.3

Instrument panel

Left / right

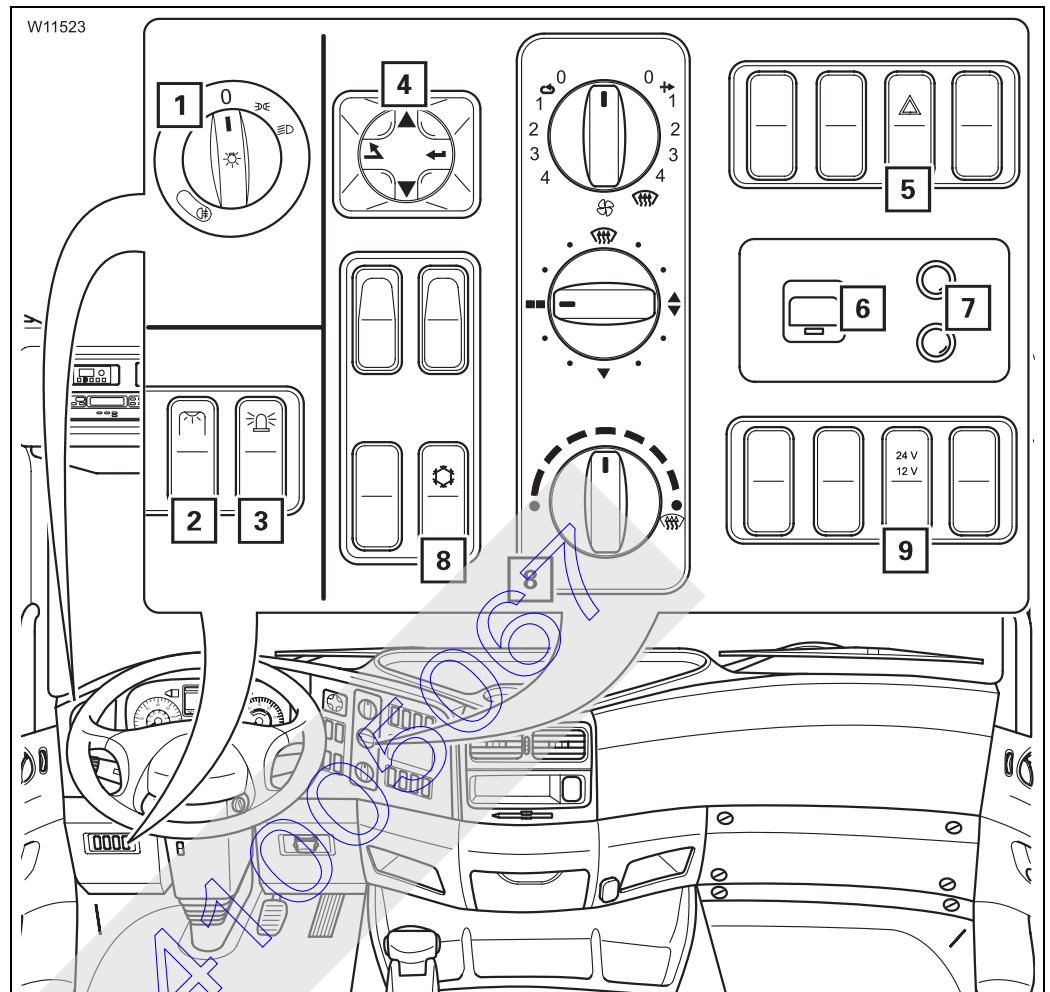

- | | |
|--|----------------|
| 1 Lighting on / off | ▣▣▣▣ p. 3 - 49 |
| 2 Outrigger lighting on / off | ▣▣▣▣ p. 3 - 49 |
| 3 Rotating beacon on / off | ▣▣▣▣ p. 3 - 49 |
| 4 Operating the on-board computer | ▣▣▣▣ p. 3 - 54 |
| 5 Hazard warning system on / off | ▣▣▣▣ p. 3 - 49 |
| 6 Data logger ^{1), 2)} | |
| 7 Soot particle filter indicator lamp – Version 1 ¹⁾
Version 2 ^{1), 2)} | ▣▣▣▣ p. 3 - 33 |
| 8 Heating / Air-conditioning system ¹⁾ | ▣▣▣▣ p. 3 - 24 |
| 9 Voltage 12 V on / off | ▣▣▣▣ p. 3 - 34 |

1) Additional equipment

2) ▣▣▣▣ *Separate operating instructions*



Middle

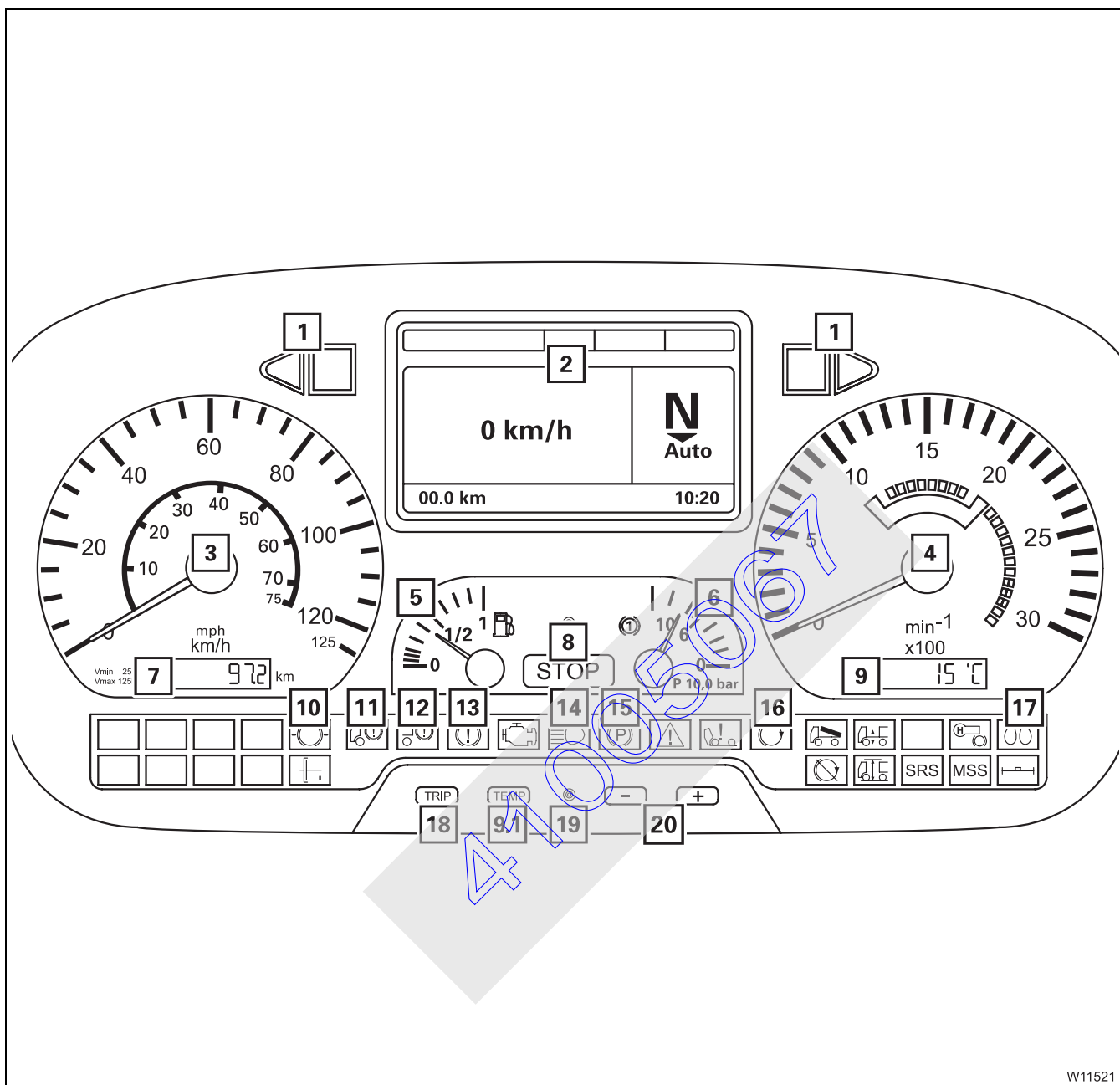

W11521

1	Indicator lamp for turn signal indicator	▶▶▶▶ p. 3 - 48
2	Display, driver's cab	▶▶▶▶ p. 3 - 10
3	Speedometer	▶▶▶▶ p. 3 - 52
4	Tachometer	▶▶▶▶ p. 3 - 33
5	Fuel level display	▶▶▶▶ p. 4 - 17
6	Display – supply pressure in brake circuits	▶▶▶▶ p. 3 - 43
7	Kilometre counter	▶▶▶▶ p. 3 - 52
8	STOP warning	▶▶▶▶ p. 3 - 33
9	Temperature of the coolant / outside air display	▶▶▶▶ p. 4 - 17
9.1	Switch over the display:	▶▶▶▶ p. 4 - 17
10	Prompt to brake	▶▶▶▶ p. 3 - 39
11	ABS warning	▶▶▶▶ p. 3 - 43
12	Trailer ABS warning lamp ¹⁾	▶▶▶▶ p. 3 - 43
13	Warning – supply pressure in the brake circuit too low	▶▶▶▶ p. 3 - 43
14	Indicator lamp for headlight – full beam	▶▶▶▶ p. 3 - 48
15	Parking brake indicator lamp	▶▶▶▶ p. 3 - 44
16	Checking the additional brake	▶▶▶▶ p. 3 - 45
17	Flame start system indicator lamp ¹⁾	▶▶▶▶ p. 3 - 33
18	Show journey data / reset	▶▶▶▶ p. 3 - 55
19	No function	
20	Instrument lighting	▶▶▶▶ p. 3 - 50
1)	Additional equipment	

3.1.4

Display, driver's cab

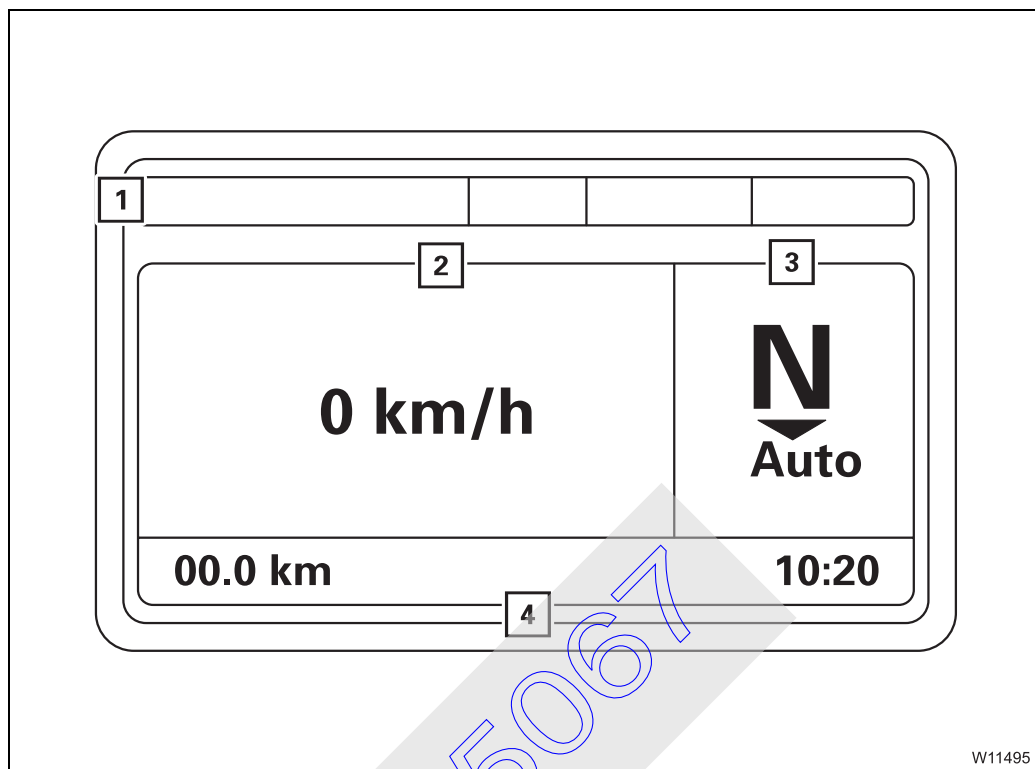

W11495

- | | |
|------------------------------|-------------|
| 1 Status display | ➡ p. 3 - 55 |
| 2 On-board computer display | ➡ p. 3 - 54 |
| 3 Transmission display | ➡ p. 3 - 37 |
| 4 Information status display | ➡ p. 3 - 54 |

3.1.5

Steering column / steering wheel

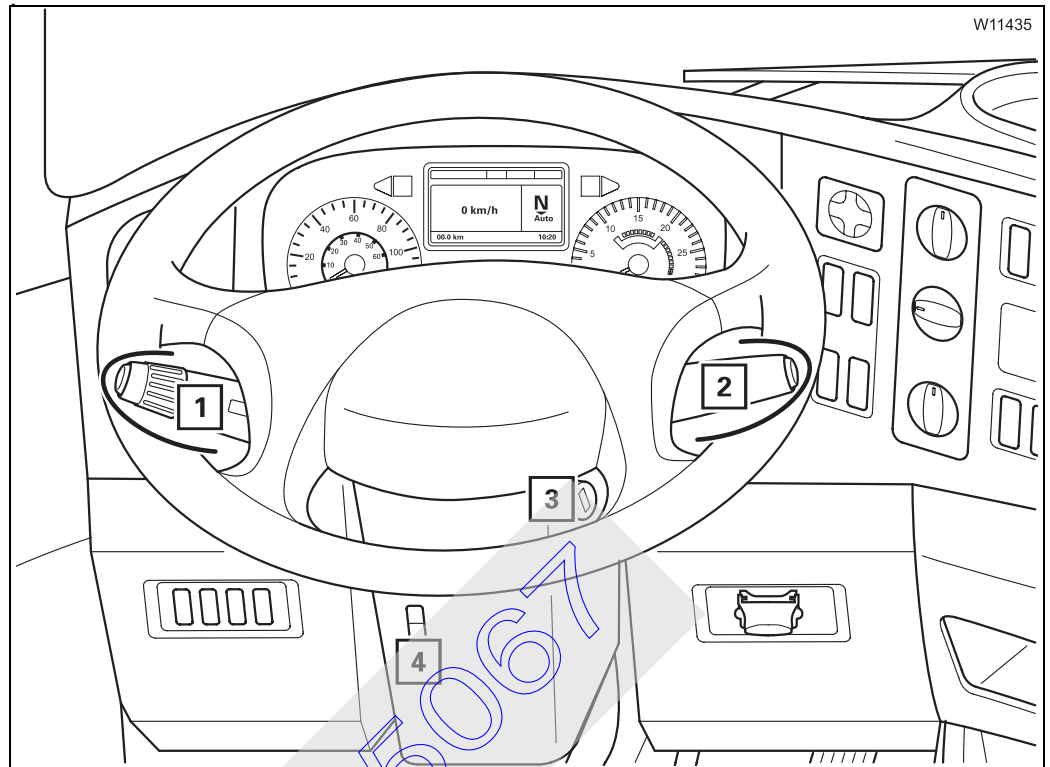

- | | |
|---|-------------|
| 1 Horn / headlight flasher / headlight – full beam | ➡ p. 3 - 48 |
| Turn signal indicator / wiper-washing system | ➡ p. 3 - 48 |
| 2 – Setting the idling speed | ➡ p. 3 - 32 |
| – Selecting tempomat / tempomat | ➡ p. 3 - 32 |
| – Setting the tempomat | ➡ p. 3 - 32 |
| – Setting the tempomat | ➡ p. 3 - 33 |
| – Engine retarder / transmission retarder ¹⁾ | ➡ p. 3 - 45 |
| 3 Ignition lock | ➡ p. 3 - 32 |
| 4 Adjusting the steering column | ➡ p. 5 - 13 |

¹⁾ Additional equipment

3.1.6

Transmission operating elements

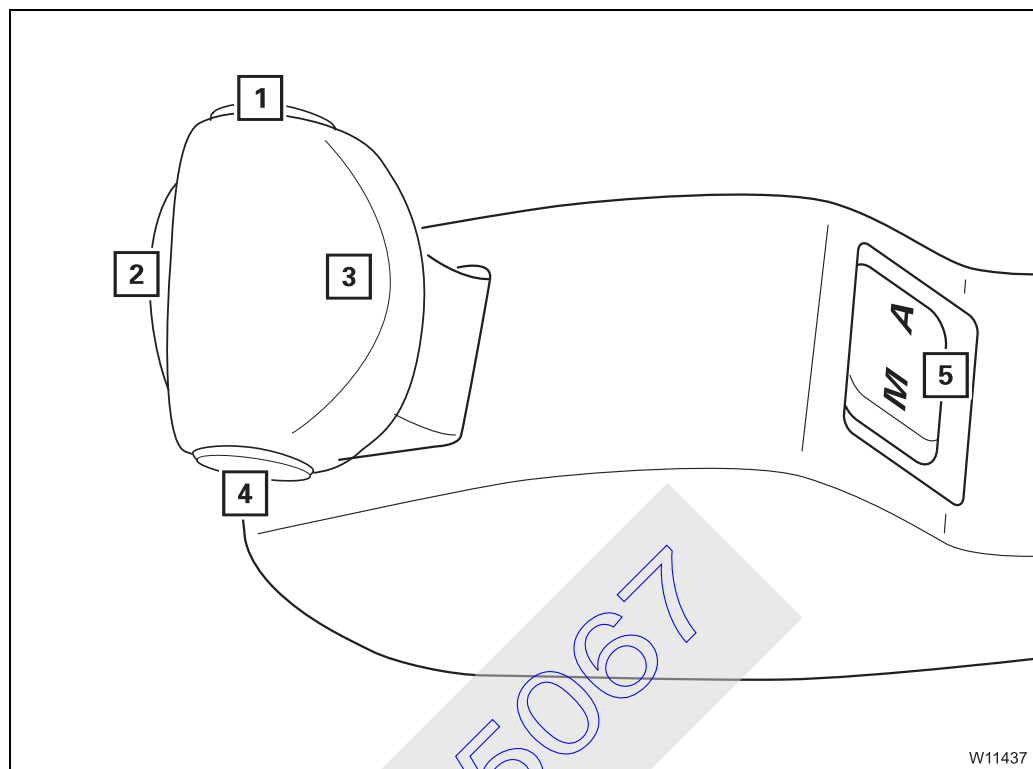

- | | |
|--|---------------|
| 1 Neutral position on | ▣▣▣ p. 3 - 38 |
| 2 Two-stop rocker | ▣▣▣ p. 3 - 39 |
| 3 Gearshift lever | ▣▣▣ p. 3 - 38 |
| 4 Additional function, gearshift lever | ▣▣▣ p. 3 - 38 |
| 5 Changing the operating mode | ▣▣▣ p. 3 - 38 |

3.1.7

Tachograph

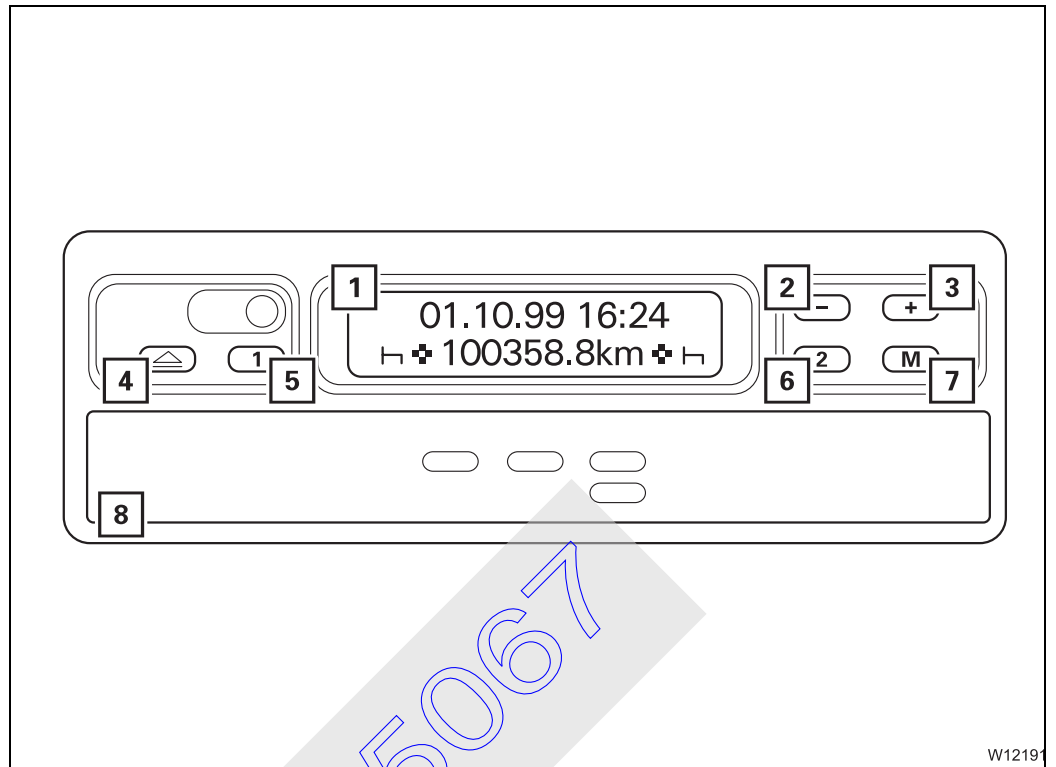

W12191

- | | |
|------------------------------------|-------------|
| 1 Display | ➡ p. 5 - 19 |
| 2 Time correction -: | ➡ p. 3 - 52 |
| 3 Time correction +: | ➡ p. 3 - 52 |
| 4 Opening the drawer | ➡ p. 5 - 17 |
| 5 Set time group – driver 1 | ➡ p. 5 - 18 |
| 6 Set time group – driver 2 | ➡ p. 5 - 18 |
| 7 Correcting the time | ➡ p. 3 - 52 |
| 8 Drawer | ➡ p. 5 - 17 |

3.1.8

ECOS control unit

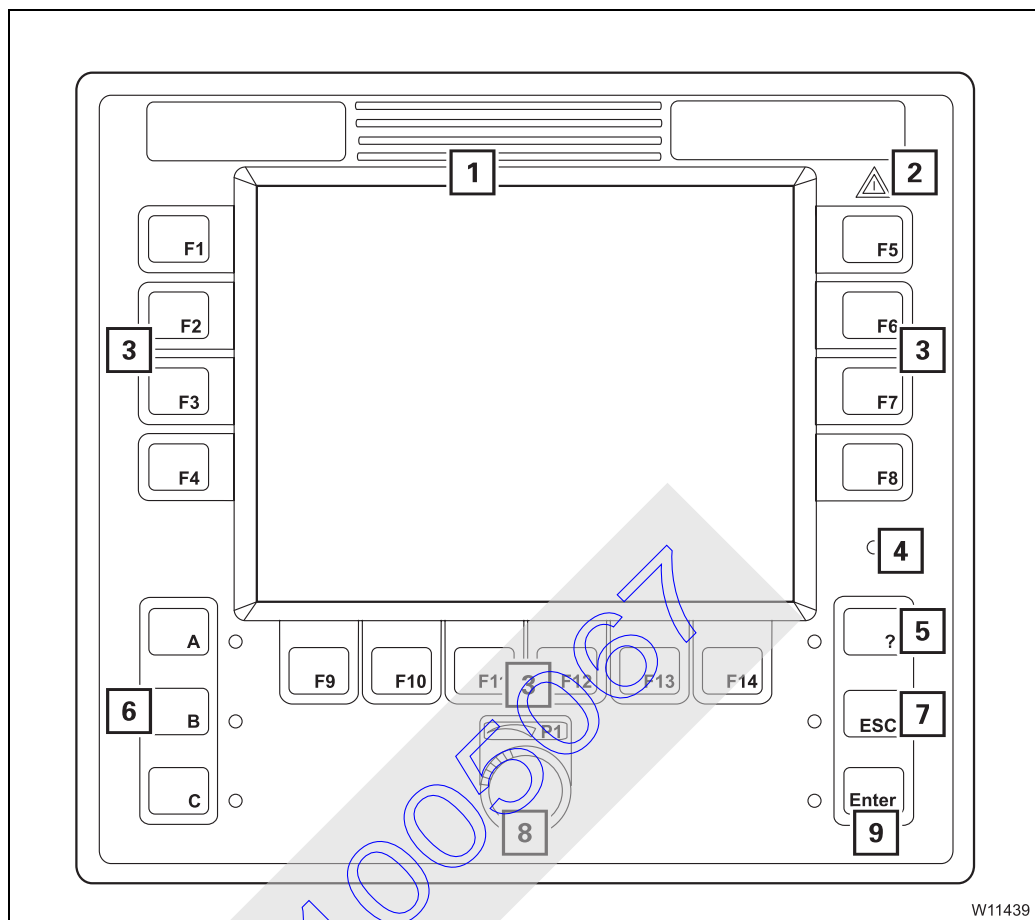

1 ECOS display	▣▣▣▣▶ p. 3 - 36
Main menu overview	▣▣▣▣▶ p. 3 - 16
2 Error / warning message	▣▣▣▣▶ p. 3 - 35
3 Buttons F1 to F14	▣▣▣▣▶ p. 3 - 34
4 Sensor for brightness	▣▣▣▣▶ p. 3 - 36
5 Error submenu	▣▣▣▣▶ p. 5 - 50
Submenu overview	▣▣▣▣▶ p. 3 - 23
6 Warning submenu	▣▣▣▣▶ p. 5 - 48
Submenu overview	▣▣▣▣▶ p. 3 - 21
7 Exiting the submenu / input mode	▣▣▣▣▶ p. 3 - 35
8 Entering values	▣▣▣▣▶ p. 3 - 35
9 Confirming an entry	▣▣▣▣▶ p. 3 - 35



Various menus are displayed on the ECOS display.

The menus are operated using buttons F1 to F14. The individual buttons have a different function in each menu. The functions of the buttons in the displayed menu correspond to the symbols next to or above the buttons; ▣▣▣▣▶ p. 3 - 34.

4100506

3.1.9

ECOS display – main menu

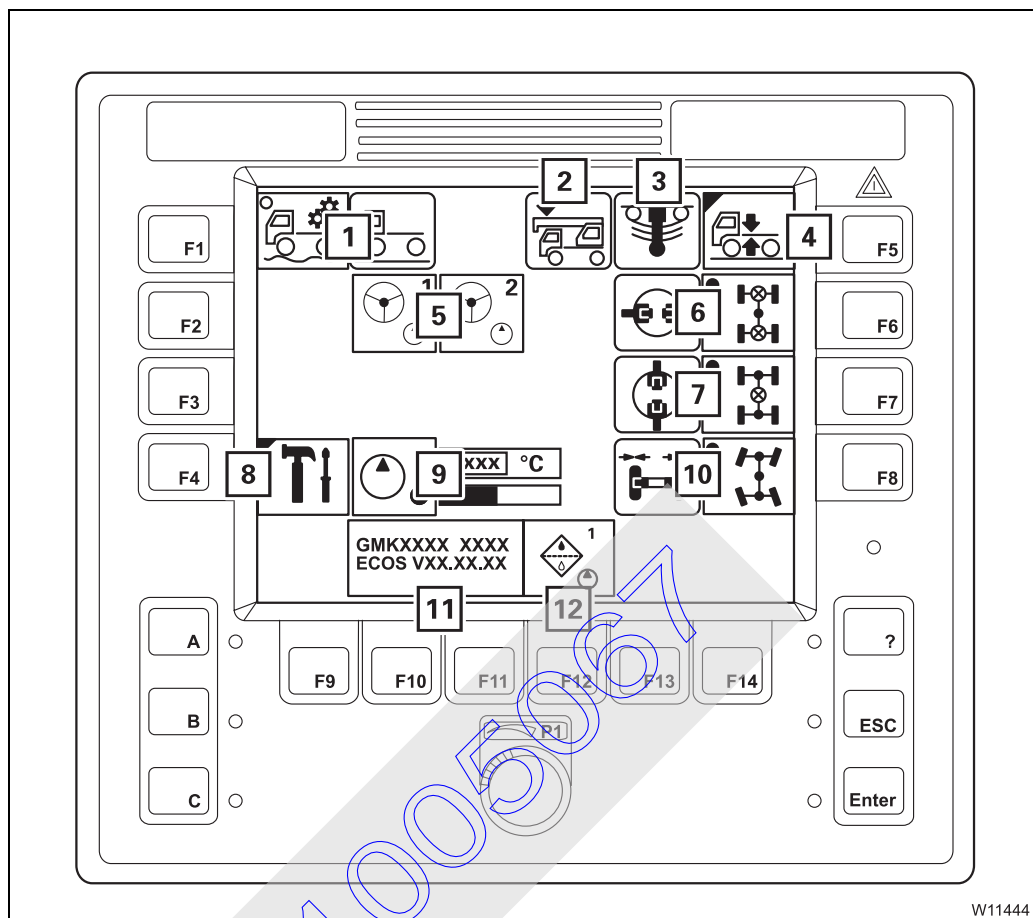

W11444

1	Transfer case for off-road gear on / off	▣▣▣▣▶ p. 3 - 41
	Transfer case display	▣▣▣▣▶ p. 3 - 41
2	Displaying the vehicle height ¹⁾	▣▣▣▣▶ p. 5 - 8
3	Suspension display	▣▣▣▣▶ p. 3 - 47
4	Level adjustment system submenu	▣▣▣▣▶ p. 3 - 18
5	Warning, steering circuit 1 and steering circuit 2	▣▣▣▣▶ p. 3 - 46
6	Transverse differential locks display	▣▣▣▣▶ p. 3 - 42
	Transverse differential locks on / off	▣▣▣▣▶ p. 3 - 42
7	Longitudinal differential locks display	▣▣▣▣▶ p. 3 - 42
	Longitudinal differential locks on / off	▣▣▣▣▶ p. 3 - 42
8	Settings submenu	▣▣▣▣▶ p. 3 - 20
9	Hydraulic oil temperature display	▣▣▣▣▶ p. 4 - 18
10	Steering locking status display	▣▣▣▣▶ p. 3 - 46
	Separate steering on / off	▣▣▣▣▶ p. 3 - 46
11	Serial number / program version display	▣▣▣▣▶ p. 3 - 36
12	Warning display	▣▣▣▣▶ p. 3 - 36

¹⁾ Additional equipment

41005067

3.1.10 ECOS display – submenus

Level adjustment system submenu

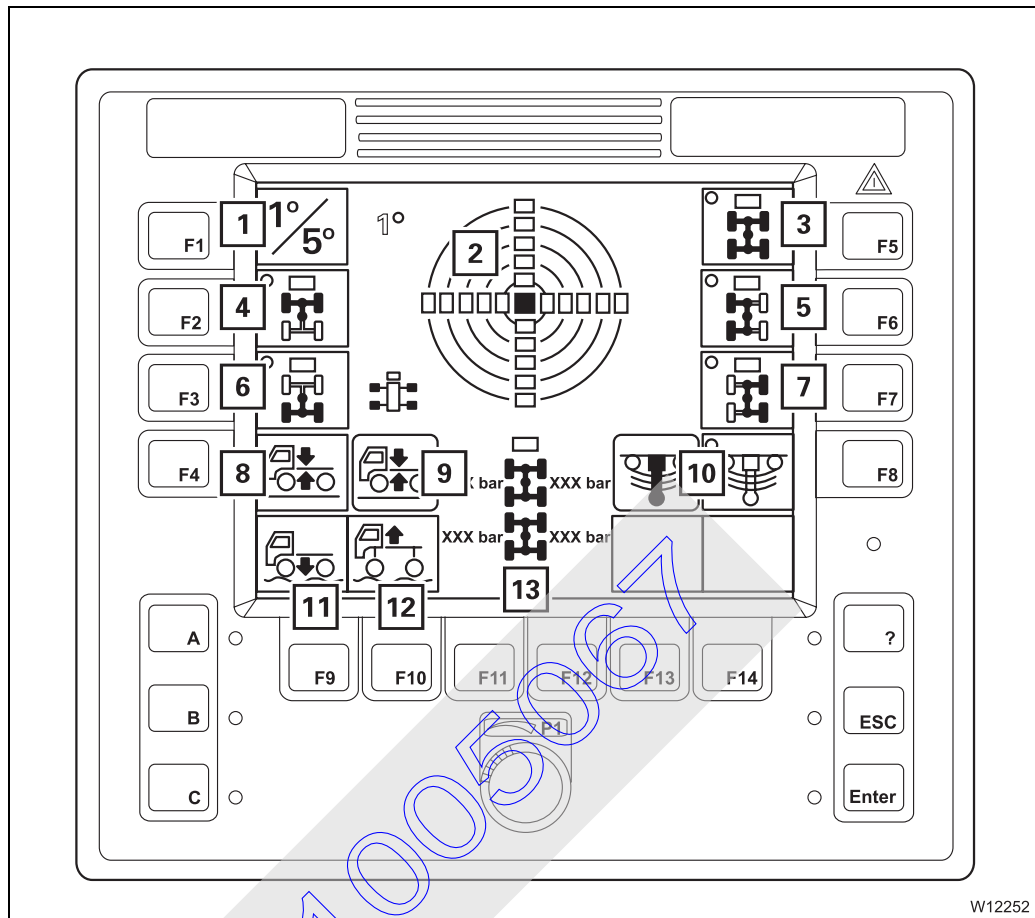

1	Switching over the measuring range	▣▣▣▣▶	p. 3 - 52
2	Display of current inclination	▣▣▣▣▶	p. 3 - 51
3	Overall level pre-selection	▣▣▣▣▶	p. 3 - 50
4	Front level pre-selection	▣▣▣▣▶	p. 3 - 50
5	Left level pre-selection	▣▣▣▣▶	p. 3 - 50
6	Rear level pre-selection	▣▣▣▣▶	p. 3 - 50
7	Right level pre-selection	▣▣▣▣▶	p. 3 - 50
8	Setting the on-road level	▣▣▣▣▶	p. 3 - 51
9	Vehicle level display	▣▣▣▣▶	p. 3 - 51
10	Suspension display	▣▣▣▣▶	p. 3 - 47
	Suspension on / off	▣▣▣▣▶	p. 3 - 47
11	Lowering / raising the level	▣▣▣▣▶	p. 3 - 51
12	Lowering / raising the level	▣▣▣▣▶	p. 3 - 51
13	Suspension operating pressure gauge¹⁾	▣▣▣▣▶	p. 3 - 47

¹⁾ Additional equipment

41005067



Settings submenu

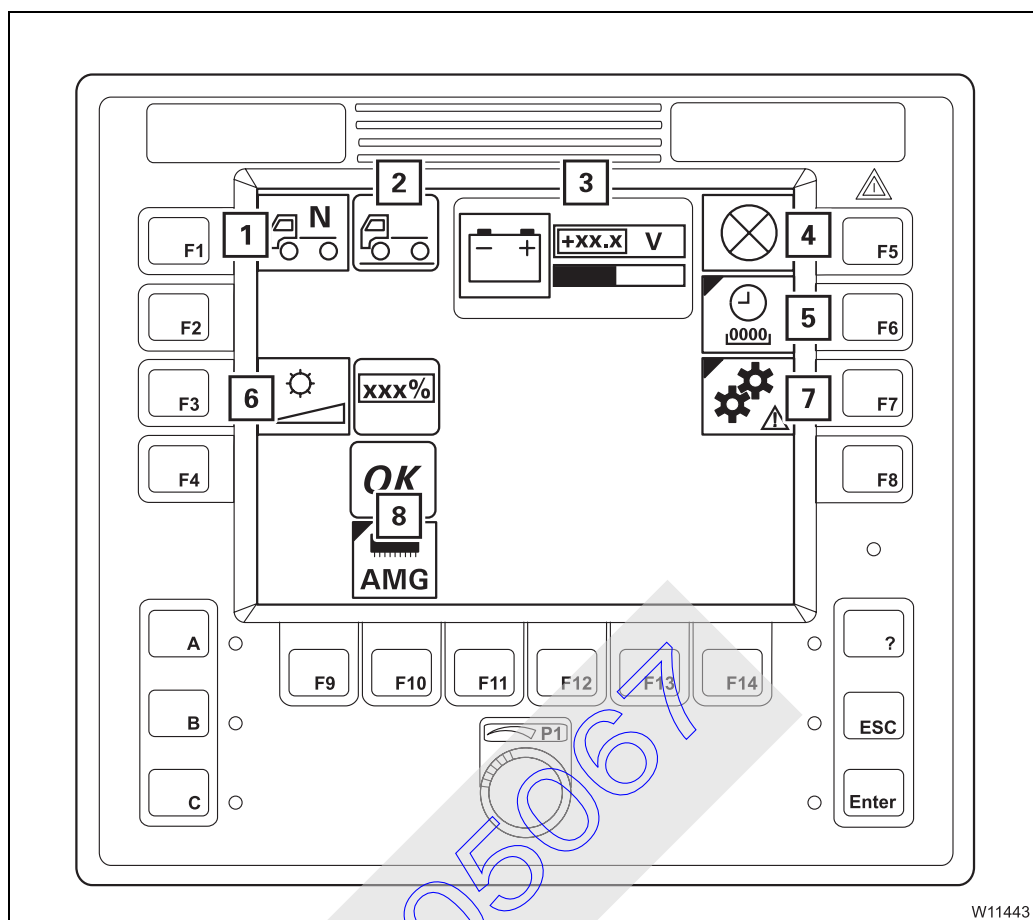

W11443

- | | |
|---|----------------|
| 1 Transfer case neutral position on | ▣▣▣▣ p. 3 - 41 |
| 2 Transfer case display | ▣▣▣▣ p. 3 - 41 |
| 3 Voltage display | ▣▣▣▣ p. 4 - 18 |
| 4 Lamp test | ▣▣▣▣ p. 4 - 10 |
| 5 Operating hours submenu | ▣▣▣▣ p. 3 - 21 |
| 6 Display – setting the brightness | ▣▣▣▣ p. 4 - 12 |
| 7 Transmission emergency program submenu | ▣▣▣▣ p. 3 - 22 |
| 8 AMG diagnostics ¹⁾ | ▣▣▣▣ p. 3 - 53 |

¹⁾ For service personnel only

Operating hours submenu

Description of the displays; *Displaying the operating hours, p. 5 - 21.*

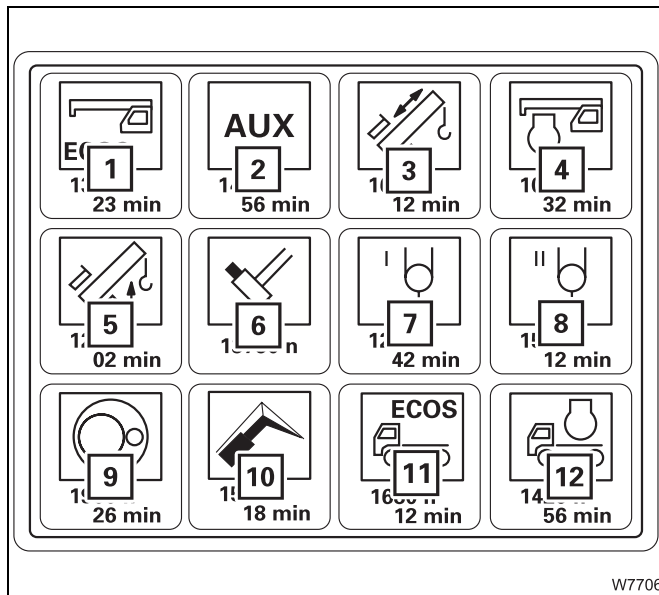

- 1 ECOS – superstructure
- 2 Auxiliary drive gears
- 3 Telescoping mechanism
- 4 Engine for crane operation
- 5 Derricking gear
- 6 Locking system
- 7 Main hoist
- 8 Auxiliary hoist¹⁾
- 9 Slewing gear
- 10 Lattice extension¹⁾
- 11 ECOS – carrier
- 12 Engine for driving

¹⁾ Additional equipment

Warning submenu

Description of the displays; *Warning submenu, p. 5 - 48.*

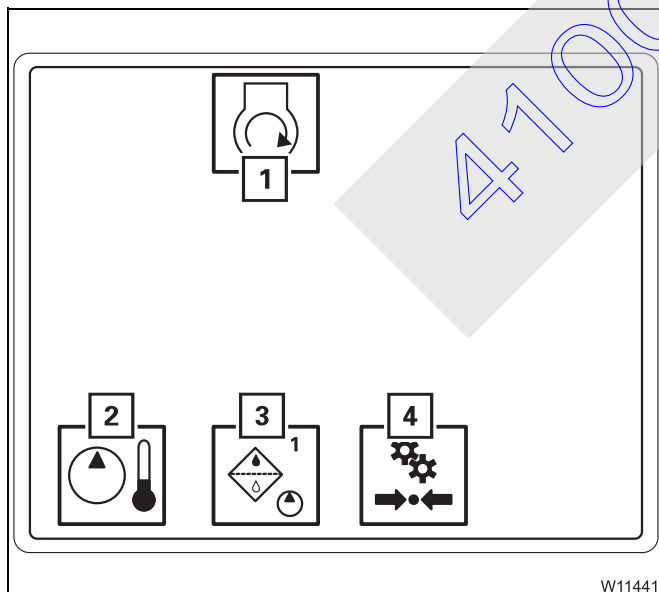

- 1 Air intake inhibitor triggered
- 2 Hydraulic oil too hot
- 3 Replacing the hydraulic oil filter
- 4 Supply pressure in secondary consumers too low



Transmission emergency program submenu

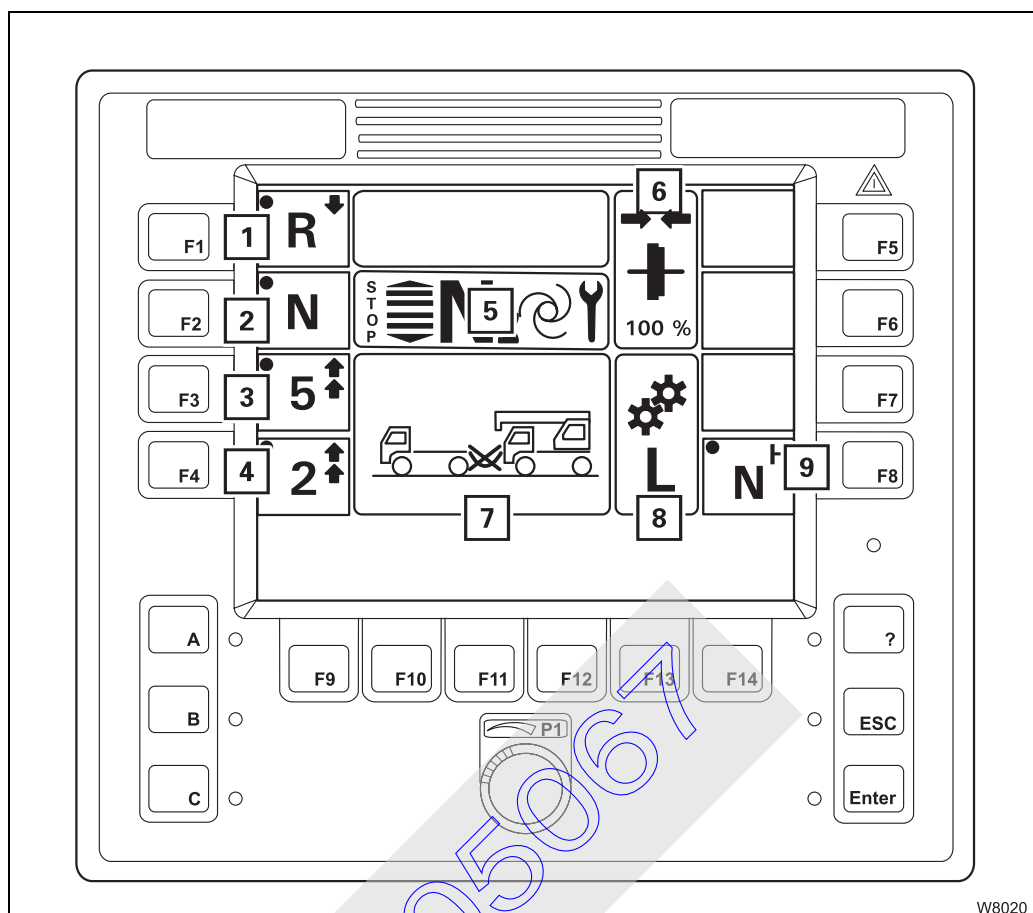

- | | |
|---------------------------------------|-------------|
| 1 Transmission mode R | ➡ p. 7 - 36 |
| 2 Neutral position | ➡ p. 7 - 36 |
| 3 Transmission mode 5 | ➡ p. 7 - 36 |
| 4 Transmission mode 2 | ➡ p. 7 - 36 |
| 5 Transmission display | ➡ p. 7 - 36 |
| 6 Clutch display | ➡ p. 7 - 36 |
| 7 Towing mode on / off display | ➡ p. 7 - 7 |
| 8 Switching group display | ➡ p. 7 - 40 |
| 9 Towing mode on | ➡ p. 7 - 7 |

Error submenu

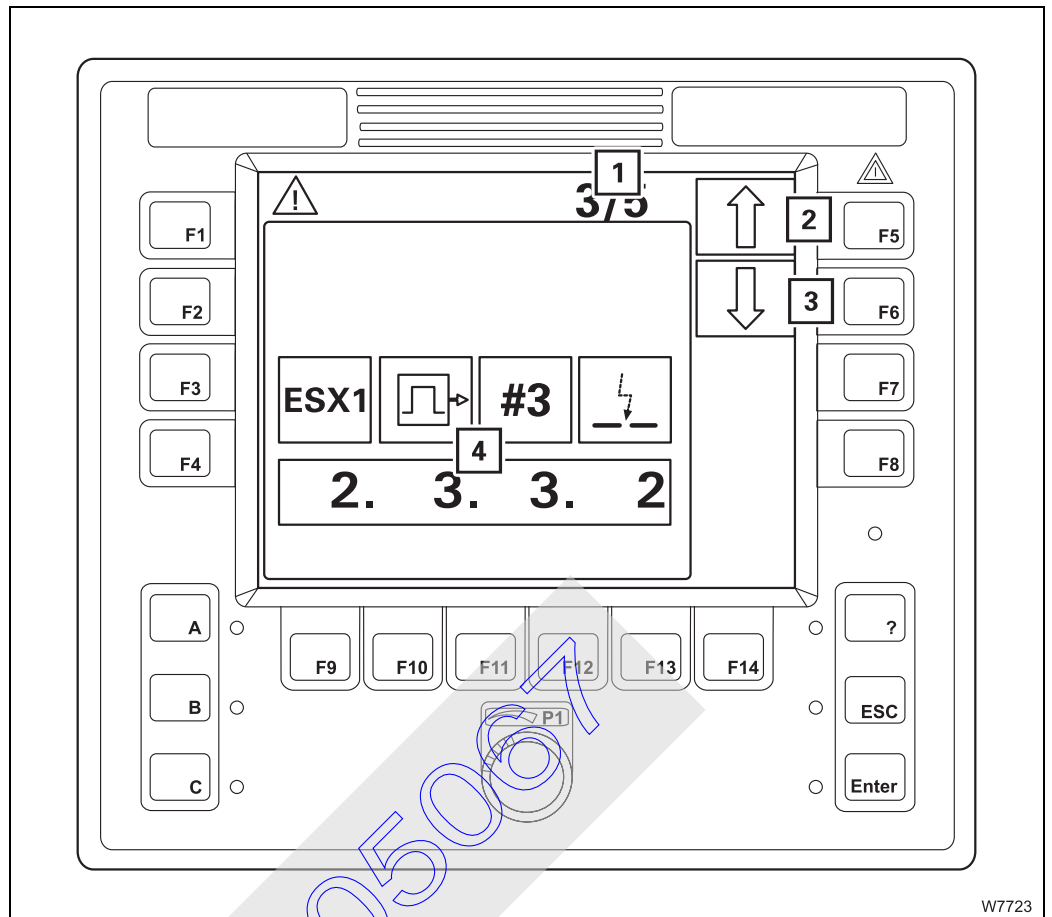

- | | |
|--|-------------|
| 1 Display of error / total errors | ▣ p. 7 - 31 |
| 2 Next error | ▣ p. 7 - 31 |
| 3 Previous error | ▣ p. 7 - 31 |
| 4 Error display | ▣ p. 7 - 32 |

3.1.11

Heating / Air-conditioning system

Standard heating system

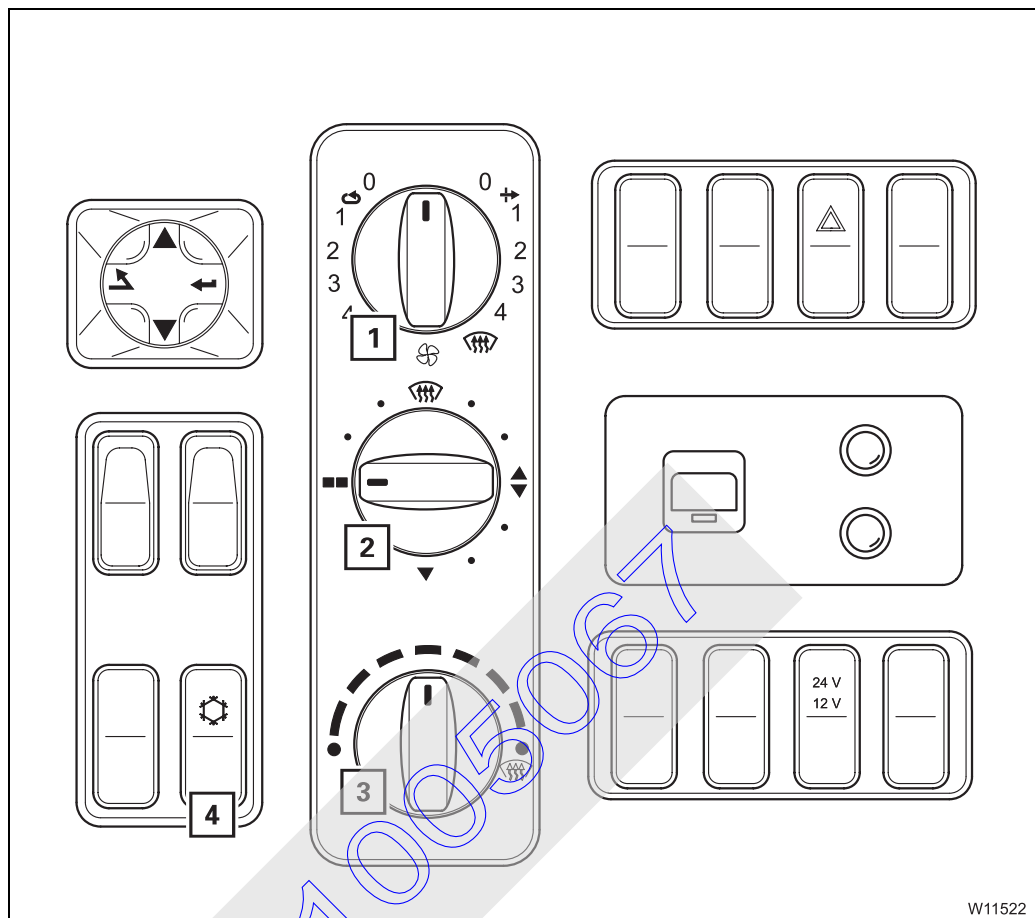

W11522

- | | | |
|---|---|-------------|
| 1 | Setting the blower / recirculated / fresh air | ➡ p. 5 - 75 |
| 2 | Air distribution | ➡ p. 5 - 76 |
| 3 | Setting the temperature | ➡ p. 5 - 75 |
| 4 | Air-conditioning system | ➡ p. 5 - 78 |

Auxiliary heater

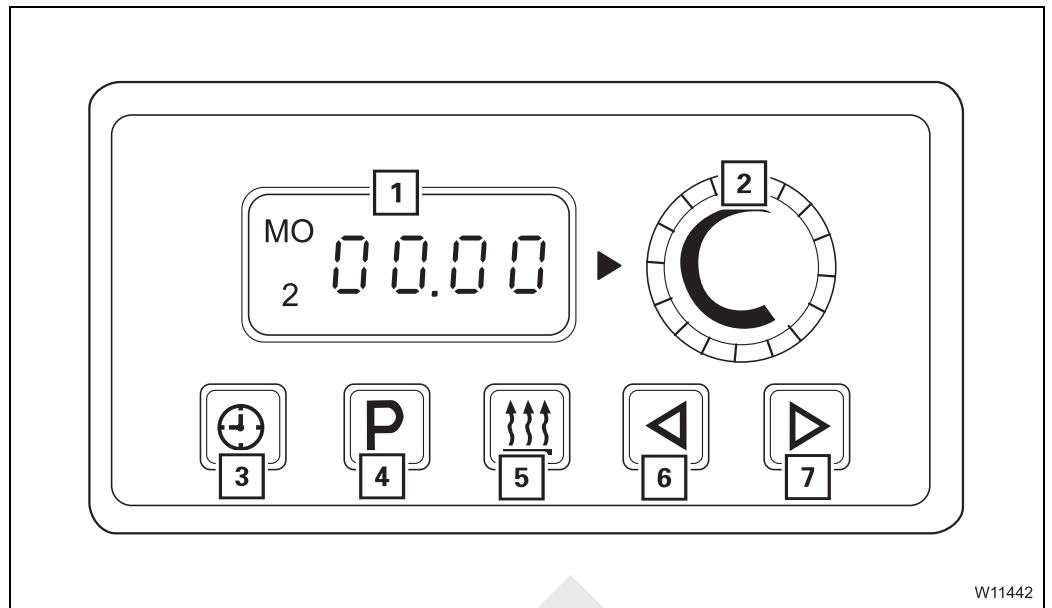

W11442

- | | |
|--|----------------|
| 1 Heater display | ▣▣▣▣ p. 5 - 81 |
| 2 Temperature | ▣▣▣▣ p. 5 - 81 |
| 3 Setting the day and time | ▣▣▣▣ p. 5 - 81 |
| 4 – Storing the heating start | ▣▣▣▣ p. 5 - 82 |
| – Switching the heating start on and off | ▣▣▣▣ p. 5 - 83 |
| 5 – Switching on | ▣▣▣▣ p. 5 - 80 |
| – Switching off | ▣▣▣▣ p. 5 - 84 |
| 6 Input – | ▣▣▣▣ p. 5 - 81 |
| 7 Input + | ▣▣▣▣ p. 5 - 81 |

3.1.12

Sockets for hand-held control

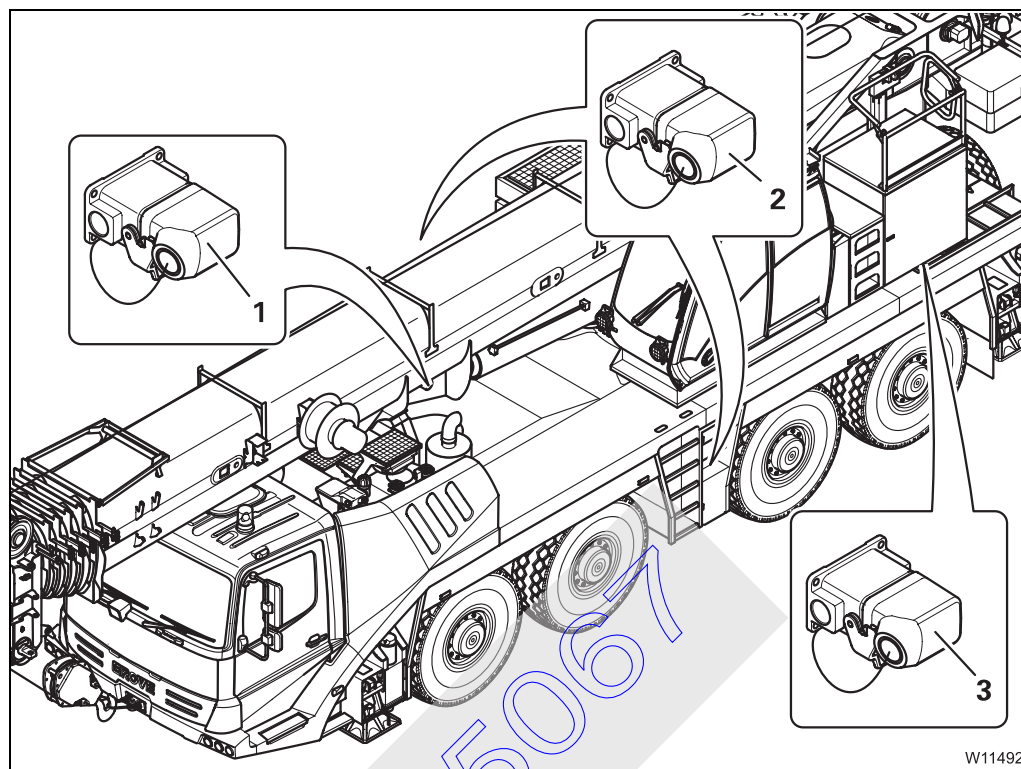

There are sockets (2) on the carrier and sockets (1) and (3) on the superstructure for the hand-held control supplied.

The hand-held control contains the operating elements for the outriggers, the inclination indicator and for driving the power units in case of emergency.

Since these operating elements are required for crane operation, they are described in Part 2 – *Crane operation*;  *Hand-held control*, p. 10 - 44.

3.1.13

Outrigger control units

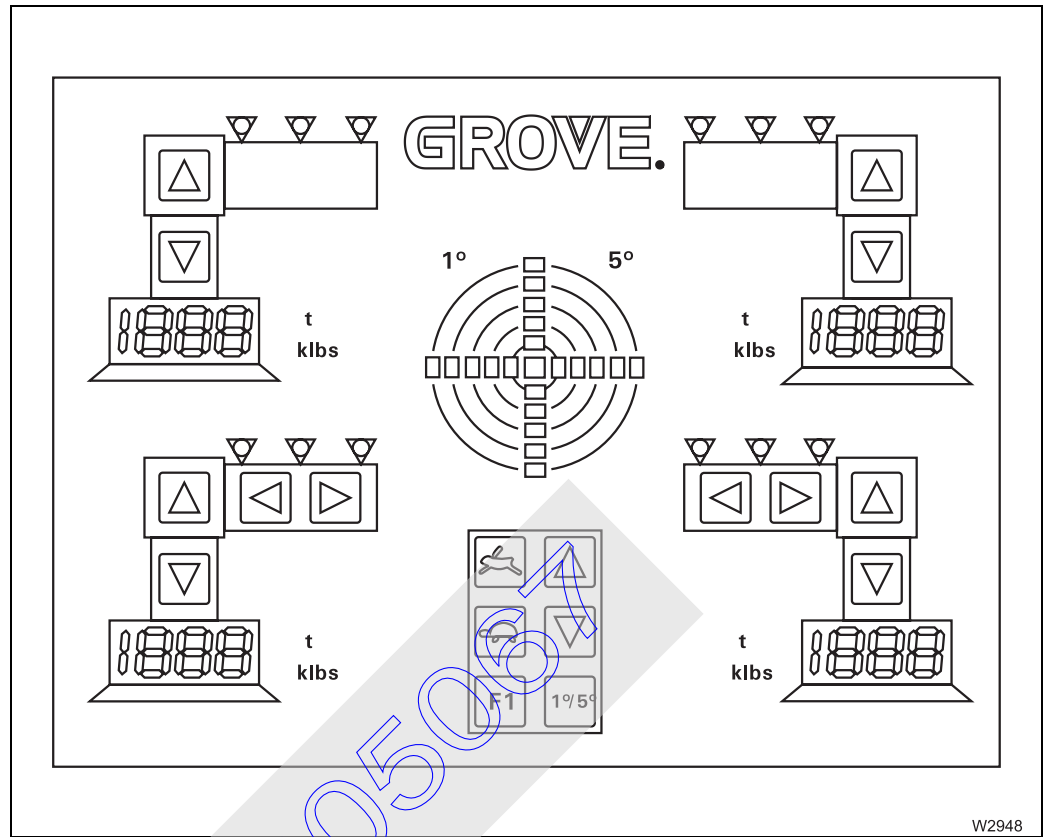

Contain operating elements for crane operation; *Outrigger control units*, p. 10 - 46.



When driving, error messages relating to the carrier electronics can be read on this display; p. 7 - 33.

Blank page

41005067

3.2

Short description of the operating elements



Risk of accidents due to operating error

This section is not a complete operating manual. It only provides a general overview of the operating element functions.

Before using the operating elements for the first time, read through the following chapters and the safety instructions listed there.



This section does not contain all of the requirements that must be fulfilled in order for several operating elements to be active.

If some operating elements do not work, first read the following chapters which are referred to at the respective places before contacting **CraneCARE**.

3.2.1

Definition of positional references

Basic rules

Directions always depend on whether the carrier or the superstructure is being operated.

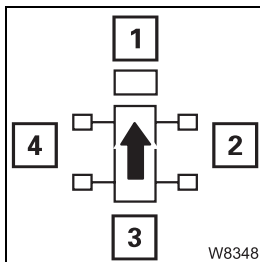

On the carrier

The driver's cab is always at the front, which means that:

- | | |
|----------|----------|
| 1: front | 2: right |
| 3: rear | 4: left |

Forwards always means the driver's cab is to the front of the direction of travel.

Backwards always means the rear lights on the carrier are to the front of the direction of travel.

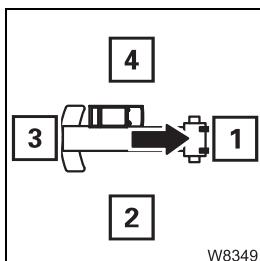

On the superstructure

The main boom head is always at the front, which means that:

- | | |
|----------|----------|
| 1: front | 2: right |
| 3: rear | 4: left |



Switches and buttons

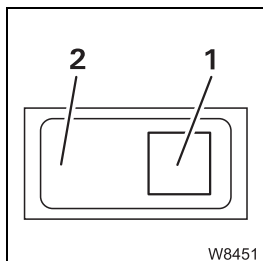

For switches and buttons, the terms **down** and **up** are used.

Regardless of the fitting position (vertical, horizontal, diagonal, perpendicular or turned), the following always applies:

- **down:** press (1) – on the symbol
- **up:** press (2) – opposite the symbol

3.2.2

General information on the operating elements

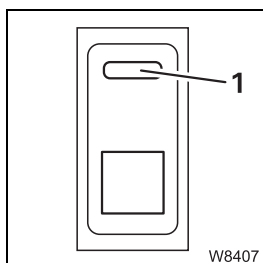

Some switches have a lock button (1). The lock button is not mentioned again during operation. The following applies to all switches with a lock button:

- **To switch on:**
 - first press the lock button
 - then press lower part of switch down
- **To switch off:** press top half of switch down until the lock button latches into place

3.2.3

General rules for buttons and symbols on the display

The symbols shown as an example are not present on all crane types. The following rules apply in all menus:

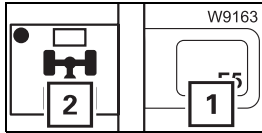

- A button (1) is only active when the corresponding symbol (2) is black. Buttons next to a grey symbol always have no function.

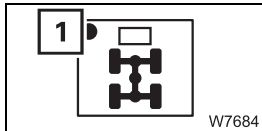

- Some symbols have a dot (1). The colour of the dot indicates the current switching state of the button.
 - **Green:** button on – the corresponding switching operation is being carried out
 - **Black:** button off – the corresponding switching operation is not being carried out

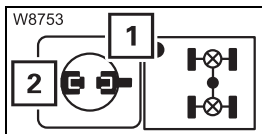

For some elements, the dot (1) only indicates that the switching operation has been completed. Here, you will also receive a report on the current switching state on an extra display (2).

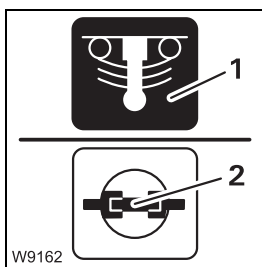

- In these operating instructions, we always refer to colours in terms of “The symbol is red”, for instance. Regardless of whether the background (1) of a symbol is red or whether only parts (2) of a symbol are red. This applies to all symbols and all colours.

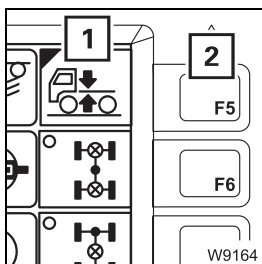

- If the instruction given in this section is to “Press the button once...”, for instance, this always refers to the button (2) next to or below the symbol shown (1). Even when the button itself is not visible in the illustration.

3.2.4 Engine

Steering column

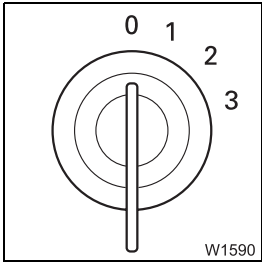

Ignition lock

- 0** Ignition off, engine off, key can be removed
- 1** Power supply on for: heating, engine / transmission diagnostics, radio / telephone
- 2** Ignition on, driving position
- 3** Starting position

▣▣▣▣ p. 4 - 9

Lock / unlock steering column ▣▣▣▣ p. 5 - 13

Multipurpose switch

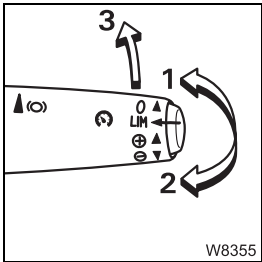

Different functions are carried out by actuating the multipurpose switch in the same way.

- Setting the idling speed

The truck crane is stationary.

- 1 Up:** increases the idling speed
- 2 Down:** reduces the idling speed
- 3 To the front:** idling speed setting off

▣▣▣▣ p. 4 - 19

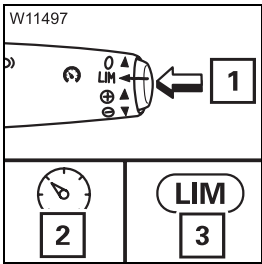

- Selecting tempomat / tempomat

- 1 Press 1 x:**
 - Display (3) – tempomat selected
 - Display (2) – tempomat selected

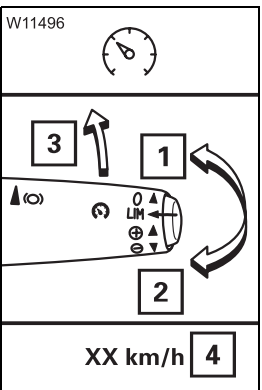

- Setting the tempomat

Tempomat selected, speed at least 15 km/h (9 mph)

- 1 Up:** switch on or increase the speed (4)
- 2 Down:** switch on or decrease the speed (4)
- 3 To the front:** switch off

Tempomat on = current speed (4) is maintained

▣▣▣▣ p. 5 - 41

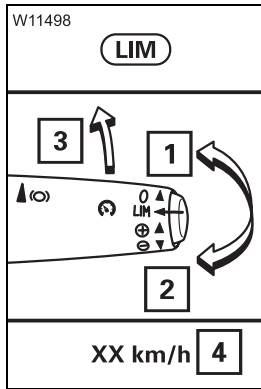

- Setting the tempuset

Tempuset selected, speed at least 15 km/h (9 mph)

- 1 Up:** switch on or increase the speed (4)
- 2 Down:** switch on or decrease the speed (4)
- 3 To the front:** switch off

Tempuset on = speed (4) is at the maximum

➡ p. 5 - 43

Instrument panel

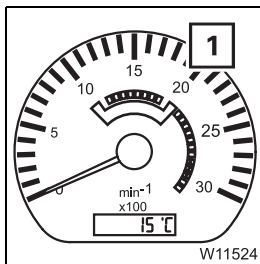

Tachometer

- 1** Display, engine speed in min^{-1} (rpm); ➡ p. 4 - 17

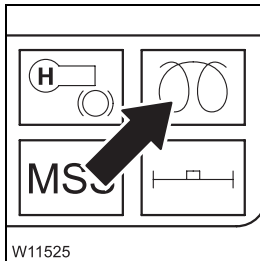

Flame start system indicator lamp

- **On:** engine not ready to start – is being warmed up
- **Off:** engine is ready to start

➡ p. 4 - 15

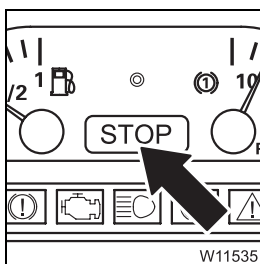

STOP warning

- **On:** Turn engine off as quickly as possible – warning buzzer sounds, warning message displayed

➡ p. 5 - 52

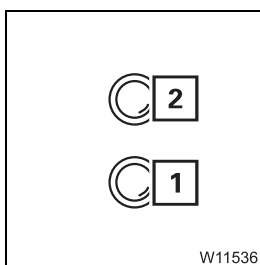

Soot particle filter indicator lamp – Version 1

- 1 Yellow lamp lights up:** early warning: clean soot particle filtering system
- 2 Orange lamp lights up:** clean / replace soot particle filtering system; ➡ *Maintenance manual*

3.2.5

Electrical system

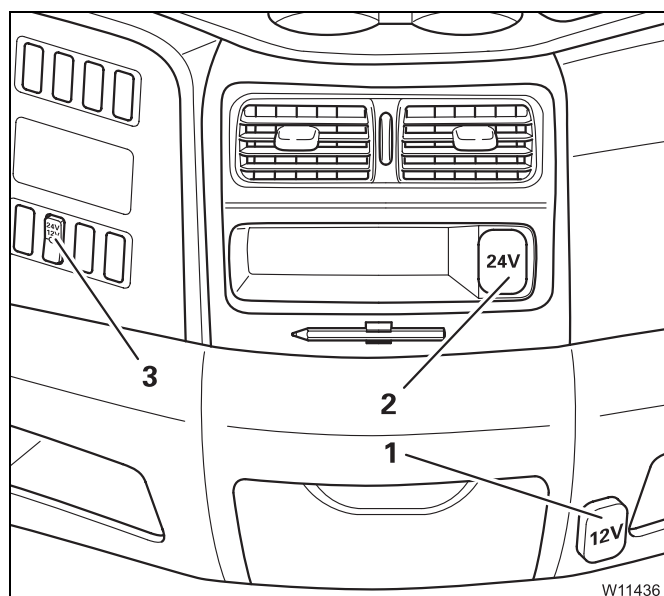

Sockets 12 V / 24 V

- 1 Socket 12 V
- 2 Socket 24 V

Voltage 12 V on / off

- 3 – on above – socket (1) voltage on
- on below – socket (1) voltage off

W11436

3.2.6

ECOS crane control

The truck crane GMK 4100 is equipped with the **ECOS** electronic crane control (**E**lectronic **C**rane **O**perating **S**ystem). ECOS includes a control unit in the crane cab, an operating unit in the driver's cab and several control units (ESX0, ESX1, ESX2 etc.) and circuit boards (I/O 0, I/O 1 etc.) which are distributed on the superstructure and carrier.

Control unit

This section contains the operating elements that are the same for all menus opened.

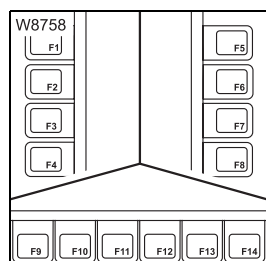

Buttons F1 to F14

The function of buttons F1 to F14 is shown on the symbol next to or above the button. After the button is pressed, the function displayed is executed if it has been released.

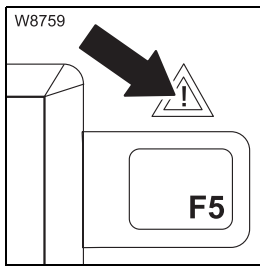

Error / warning message

- **Flashing:** new warning message or error has occurred
- **On:** error acknowledged – but still present
- **Off:** no warning message or error present

➡ p. 12 - 106

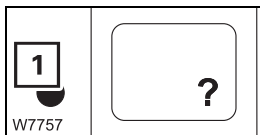

Opening the Error submenu

The lamp (1) lights up or flashes.

- **To open:** Press button once – submenu opens

➡ p. 12 - 106

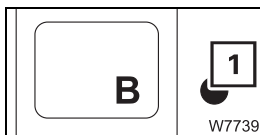

Opening the Warning submenu

The lamp (1) lights up or flashes.

- **To open:** Press button once – submenu opens

➡ p. 5 - 48



Exiting the submenu / input mode

The lamp (1) lights up.

- **Press button once:** – the opened submenu closes – the menu from the next level up opens
- Input mode is deactivated



Confirming an entry

The lamp (1) lights up.

- **Press button once:** a newly entered value is stored

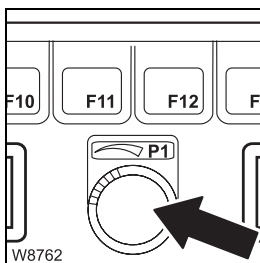

Entering values

Input mode is activated.

- **To the right:** increases the value
- **To the left:** reduces the value

Slow turning changes the value slowly.
Fast turning changes the value fast.



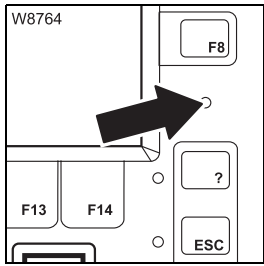

Sensor for brightness

Registers the brightness of the operating environment. The brightness of all displays is automatically adjusted.
Manual input; p. 4 - 12.

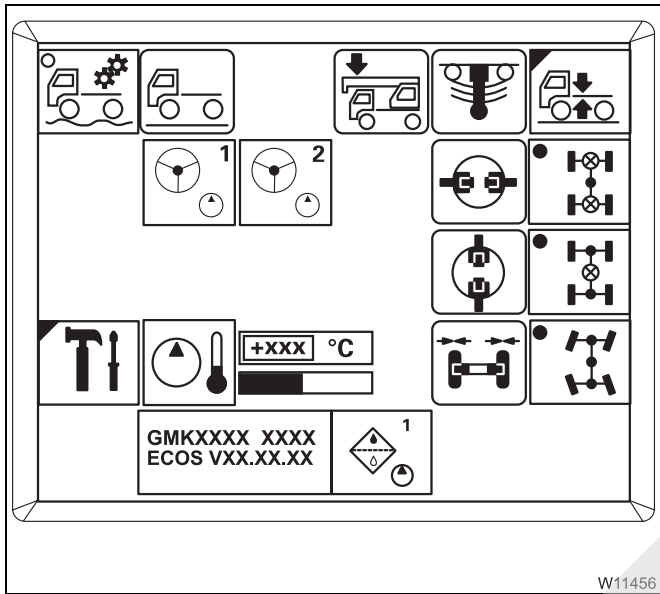

ECOS display

The main menu appears after switching on the ignition.

Symbols which represent submenus are indicated at the top left by a blue corner.

Submenus are opened by pressing the button next to or under the respective symbol.

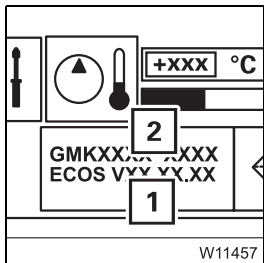

Serial number / program version display

- 1 Current ECOS program version – always state in the event of malfunctions; p. 7 + 30.
- 2 Serial number

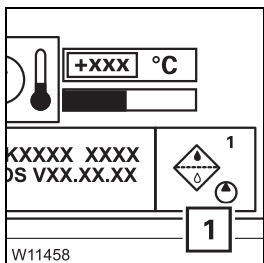

Warning display

- 1 Shows the symbol of a current warning message – for several warning messages, the displays are shown one after the other in continuous sequence; p. 5 - 48.

3.2.7

Transmission

Transmission display

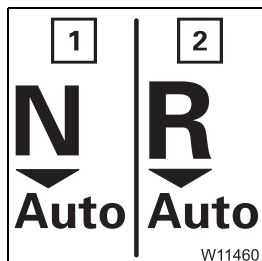

Operating the transmission, p. 5 - 29.

Transmission display

- 1 Neutral position switched on
- 2 Currently selected gear – reverse

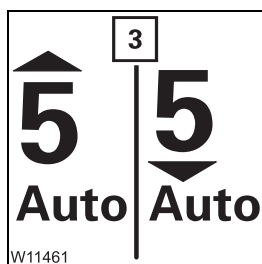

- 3 Currently selected gear – forwards (1 to 8) e.g. 5

– Arrow pointing up: full gear

– Arrow pointing down: ½ gear

Operating p. 5 - 31

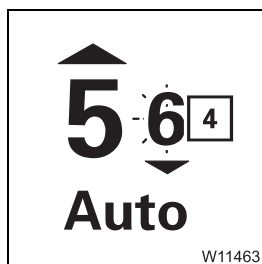

- 4 – Flashing: previously selected gear, e.g. 6

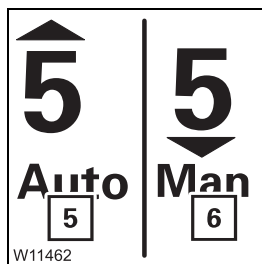

- 5 *Automatic* operating mode on
- 6 *Manual* operating mode on

ECOS display

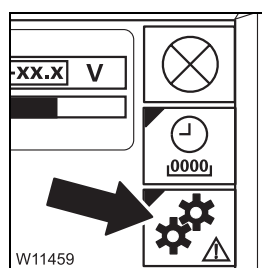

Transmission emergency program submenu

– To open: Press button once – submenu opens

Operating p. 7 - 38



Operating elements

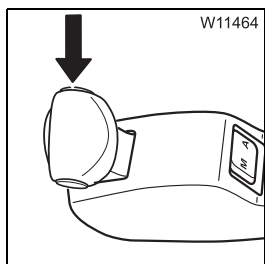

Neutral position on

- **Press once:** Neutral position on
- |||▶ p. 5 - 30

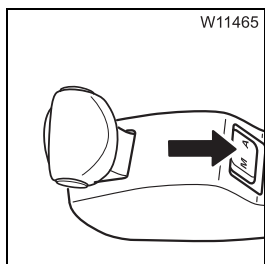

Changing the operating mode

- **Position A:** *Automatic* operating mode on
 - **Position M:** *Manual* operating mode on
- |||▶ p. 5 - 30

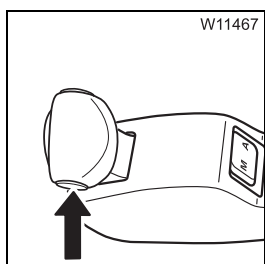

Additional function, gearshift lever

Use always in combination with the gearshift lever.

- **Press:** gearshift lever function changed
- |||▶ *Gearshift lever*

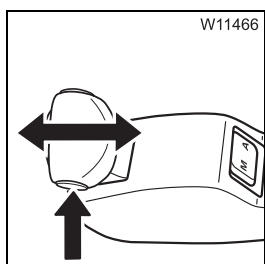

Gearshift lever

- The truck crane is stationary.
 - **Additional function +** starting gear engaged – forwards
 - Push forwards once:**
 - **Additional function +** starting gear engaged – reverse; depending on the equipment, an acoustic signal can be heard.
 - Push to the rear once:**

|||▶ p. 5 - 31

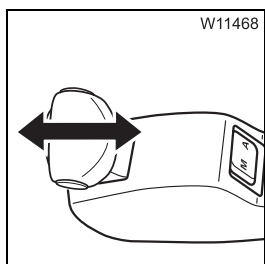

- The starting gear is engaged
 - **Push forwards once:** shift up starting gear – 1 gear
 - **Push to the rear once:** shift down starting gear – 1 gear
- |||▶ p. 5 - 32

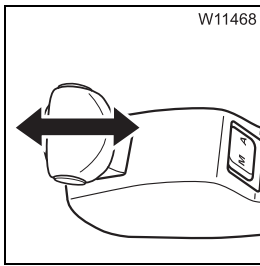

- The truck crane is in motion.
 - **Push forwards once:** Upshifting
 - **Push to the rear once:** Downshifting
- The gear is selected automatically; p. 5 - 34

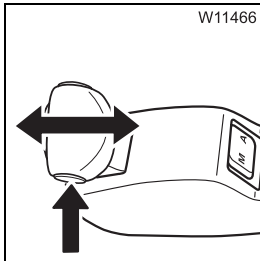

- **Additional function +** shift up – 1 gear
 - **Push forwards once:**
 - **Additional function +** shift down – 1 gear
 - **Push to the rear once:**
- p. 5 - 35

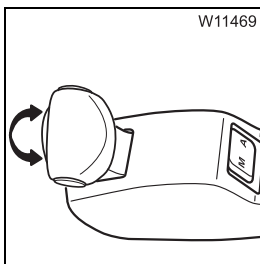

- Two-stop rocker**
- The truck crane is stationary – starting gear engaged
 - **Push up once:** shift up starting gear – ½ gear
 - **Push down once:** shift down starting gear – ½ gear
- p. 5 - 32

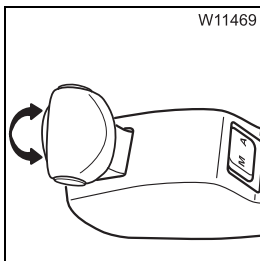

- The truck crane is in motion.
 - **Push up once:** shift up – ½ gear
 - **Push down once:** shift down – ½ gear
- p. 5 - 35

Instrument panel

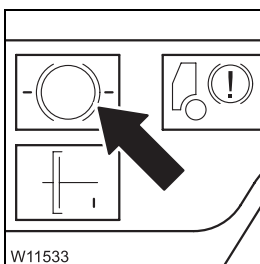

- Prompt to brake**
- **On:** downshifting not possible; warning buzzer sounds – brake truck crane
- p. 5 - 35

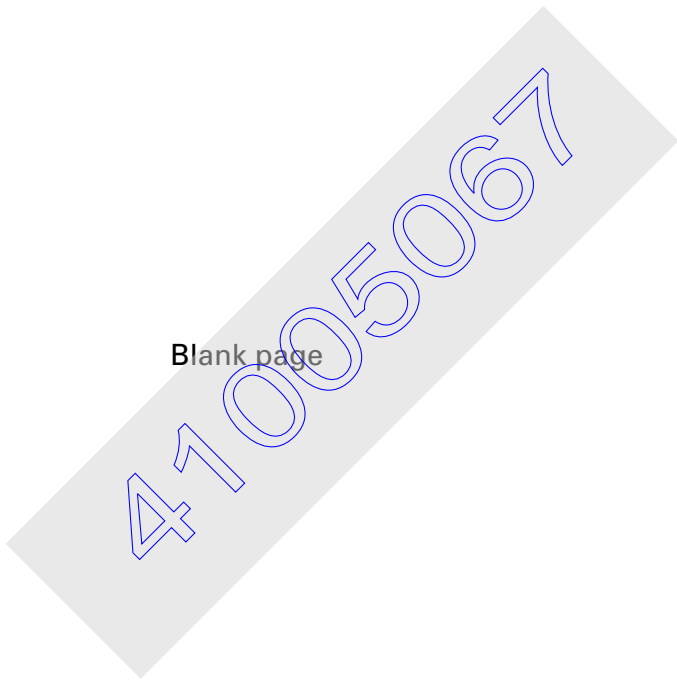

3.2.8

Transfer case

Main menu

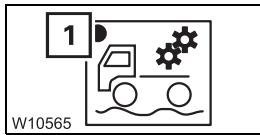

Transfer case for off-road gear on / off

- **To switch on:** Press button once – dot (1) green
- **To switch off:** Press button once – dot (1) black or switch to neutral position

➡ p. 5 - 62

Settings submenu

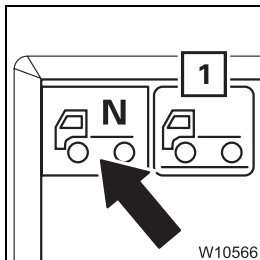

Transfer case neutral position on

- **To switch on:** Press button once – display symbol (1)
- **To switch off:** Switch the off-road gear on / off (in the main menu)

➡ p. 7 - 8

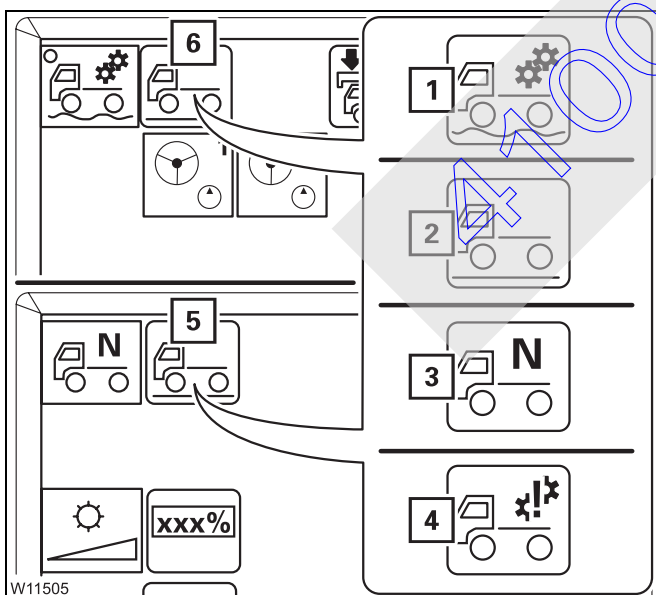

Transfer case display

The current status is shown using different symbols:

- 1 Off-road gear on
- 2 Off-road gear off – on-road driving
- 3 Neutral position on
- 4 Error – violet

The displays in the main menu (6) and the *Settings* submenu (5) always show the same symbol.

3.2.9 Final drive

▣▣▣▣ *Longitudinal and transverse differential locks, p. 5 - 63*

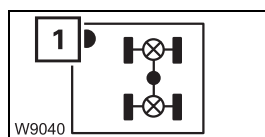

Transverse differential locks on / off

- **To switch on:** Press button once – dot (1) green, maximum 20 km/h (12 mph)
- **To switch off:** Press button once – dot (1) black

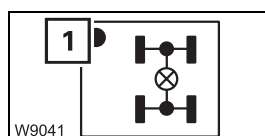

Longitudinal differential locks on / off

- **To switch on:** Press button once – dot (1) green, maximum 20 km/h (12 mph)
- **To switch off:** Press button once – dot (1) black

With additional equipment, the drive of the second axle line is switched on and off simultaneously.

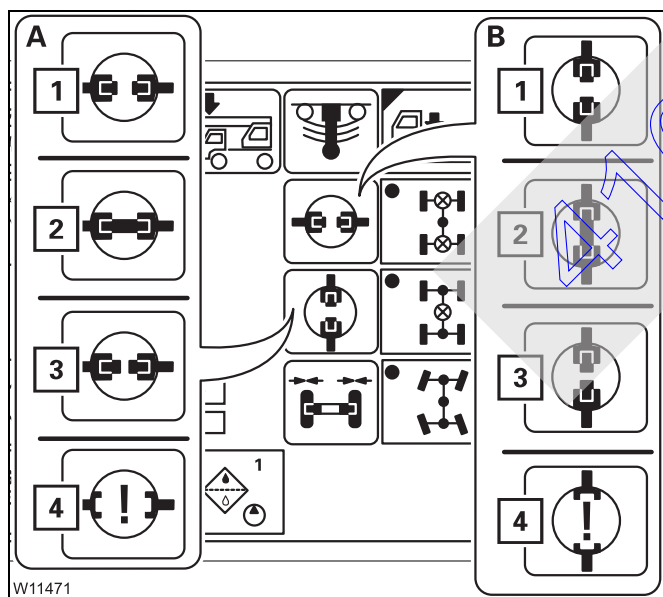

A Transverse differential locks display
B Longitudinal differential locks display

The current status is shown using different symbols:

- 1 Green – locks off
- 2 Red – locks on
- 3 Yellow – intermediate position
- 4 Violet – error

3.2.10

Brakes

Service brake

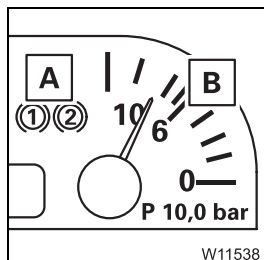

Display – supply pressure in brake circuits

- A** Brake circuit with low supply pressure – display 1 or 2
- B** Current supply pressure in the brake circuit displayed (**A**) in bar

Display on the *on-board computer display*; *Supply pressure*, p. 5 - 23

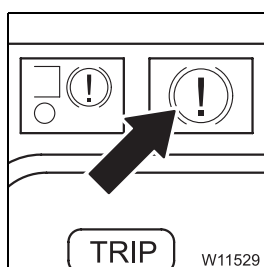

Warning – supply pressure in the brake circuit too low

- **On:** Supply pressure below approx. 5 bar (73 psi)
- **Off:** Supply pressure above 5.5 bar (80 psi)

p. 5 - 50

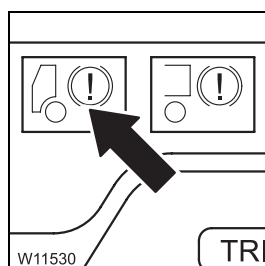

ABS warning

- **On:** approx. 6 km/h (4 mph) not reached
or
ABS defective
- **Off:** approx. 6 km/h (4 mph) exceeded, and ABS ready to function

p. 5 - 40

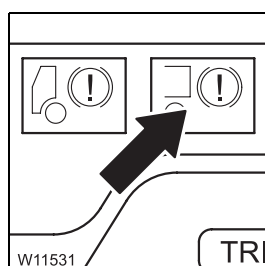

Trailer ABS warning lamp

- **On:** approx. 6 km/h (4 mph) not reached
or
ABS trailer faulty
- **Off:** approx. 6 km/h (4 mph) exceeded, and ABS trailer ready to function

p. 5 - 40



Parking brake

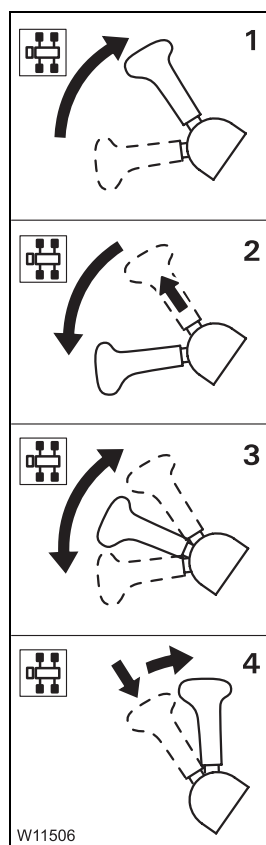

- 1 To engage the parking brake:** Pull the lever back until it locks into place
- 2 To release the parking brake:** Lift the lever and push to the front until it latches into place
- 3 Operation as an auxiliary brake:** Shift the lever to intermediate position. The braking force is increased continuously by moving the lever from the front to the rear.
- 4 Test position for towing a trailer:**
 - Pull the lever back until it locks into place
 - Press in the lever and pull it further backwards
 The parking brake for the trailer is released;

 ►► p. 5 - 90

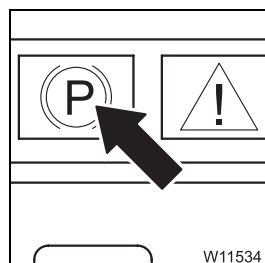

- Parking brake indicator lamp**
- **On:** parking brake engaged
 - **Off:** parking brake released

Additional brakes

Engine retarder / transmission retarder

▣▣▣▣ *Additional brakes*, p. 5 - 46

Multipurpose switch

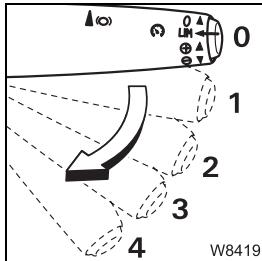

- 0 To the front:** Engine retarder and transmission retarder off
- 1 To the rear:** Engine retarder
- 2 To the rear:** Engine retarder, transmission retarder 50%
- 3 To the rear:** Engine retarder, transmission retarder 75%
- 4 To the rear:** Engine retarder, transmission retarder 100%

Instrument panel

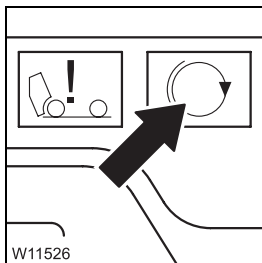

Checking the additional brake

- **On:** Engine retarder / transmission retarder on
- **Off:** Engine retarder / transmission retarder off

41005067

3.2.11 Steering / separate steering

▣▣▣▣▶ *Separate steering*, p. 5 - 71

ECOS display

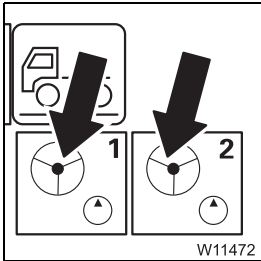

Main menu

Warning, steering circuit 1 and steering circuit 2

- **Red:** approx. 10 km/h (6 mph) not reached
or
with 1 lamp – sluggish steering
with 2 lamps – steering faulty – stop
- **Grey:** approx. 10 km/h (6 mph) exceeded, and steering OK

▣▣▣▣▶ p. 5 - 39

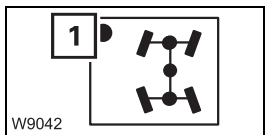

Separate steering on / off

- **To switch on:** press button once – dot (1) green
- **To switch off:** press button once – dot (1) black

▣▣▣▣▶ p. 5 - 71

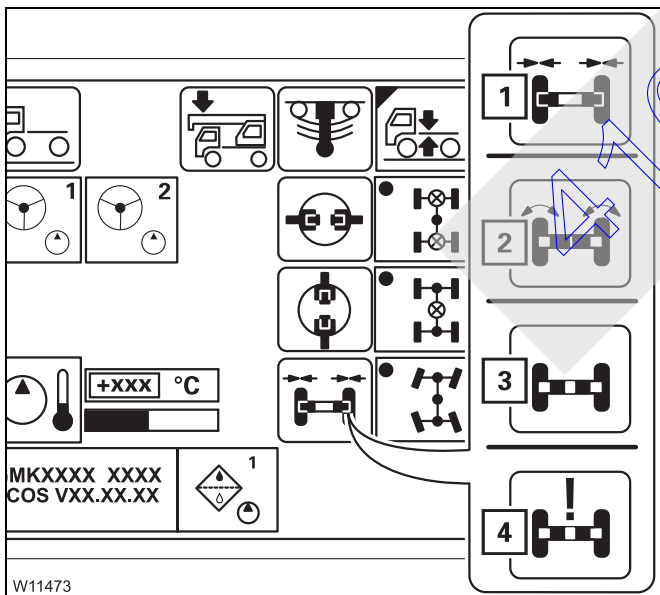

Steering locking status display

The current status is shown using different symbols:

- 1 Green – locked
- 2 Red – unlocked
- 3 Yellow – intermediate position
- 4 Violet – error

▣▣▣▣▶ p. 5 - 71

Driver's door

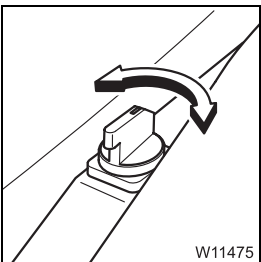

Separate steering

The separate steering is switched on.

- **To the left:** third and fourth axle lines – turn to the left
- **To the right:** third and fourth axle lines – turn to the right

▣▣▣▣▶ p. 5 - 72

3.2.12

Suspension

▣▣▣▣ Switching the suspension on / off, p. 5 - 14.

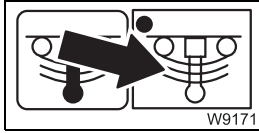

Suspension on / off

– **To switch on:** Press button once – dot green

– **To switch off:** Press button once – dot black

▣▣▣▣ p. 5 - 15

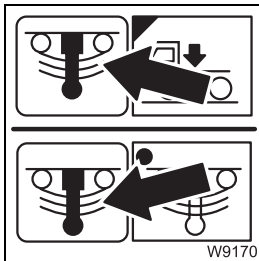

Suspension display

In the main menu and in the *level adjustment system* submenu

– **Green:** suspension on – enabled for on-road driving

– **Red:** suspension off – blocked for crane operation

▣▣▣▣ p. 5 - 15

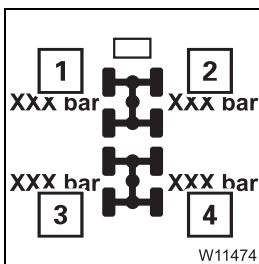

Suspension operating pressure gauge

1 Suspension pressure, first and second axle lines, left-hand side

2 Suspension pressure, first and second axle lines, right-hand side

3 Suspension pressure, third and fourth axle lines, left-hand side

4 Suspension pressure, third and fourth axle lines, right-hand side

3.2.13 Lighting / windscreen wipers / horn

Steering column

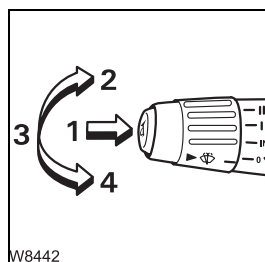

Multipurpose switch

Horn / headlight flasher / headlight – full beam

- 1 **Horn:** press the button
- 2 **Headlight flasher:** upward
- The parking light / headlight is switched on:
- 3 **Parking light / headlight:** middle position
- 4 **Full-beam headlight:** down – latches into place

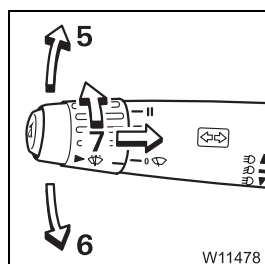

Turn signal indicator / wiper-washing system

- 5 **Right turn signal indicator:** forwards
- 6 **Left turn signal indicator:** backwards
- 7 **Windscreen wiper / washing system:** press
- 7 **Windscreen wiper:** turn – off (0) interval, slow, fast
- 7 **Adjusting the wiper stroke interval:**
 - Switch on the interval
 - Switch off after the first wipe (0)
 - Wait for the required time (maximum 20 seconds)
 - Switch on the interval – required time = pause between wipes

Instrument panel

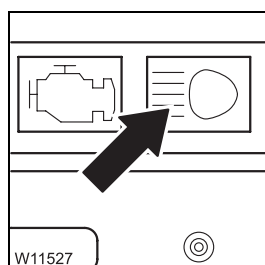

Indicator lamp for headlight – full beam

- **On:** headlight – full beam on
- **Off:** headlight – full beam off

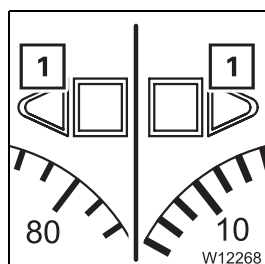

Indicator lamp for turn signal indicator

- 1 – **Flashing:** turn signal indicator on
- **Off:** turn signal indicator off, or turn signal indicator on and bulb defective

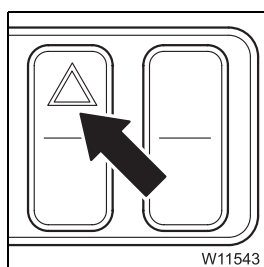

W11543

Hazard warning system on / off

- **To switch on:** press upwards – light in the switch flashes
- **To switch off:** press down

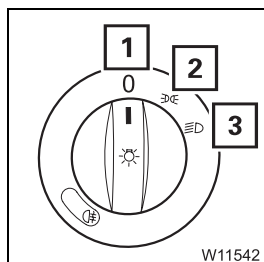

W11542

Lighting on / off

- 1 Light off**
- 2 Parking light on** Instrument lighting on
- 3 Headlight on** Headlight – full beam can be switched on using the multipurpose switch

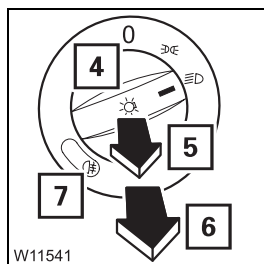

W11541

The headlight or parking light is switched on.

- 4 Fog tail light off**
- 5 No function**
- 6 Fog tail light on**
– Light (7) on

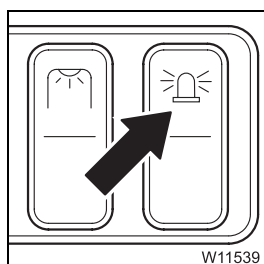

W11539

Rotating beacon on / off

- **To switch on:** press up
- **To switch off:** press down

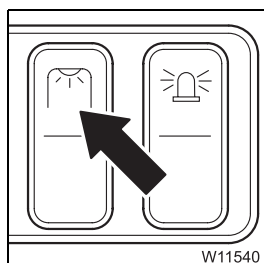

W11540

Outrigger lighting on / off

- **To switch on:** press up
- **To switch off:** press down



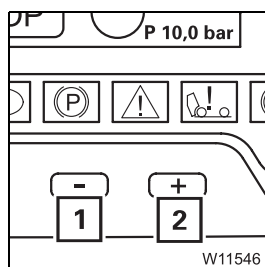

Instrument lighting

The headlight or parking light is switched on.

- 1 Instrument lighting darker
- 2 Instrument lighting brighter

Roof

The lamps on the driver's and passenger's side are identical.

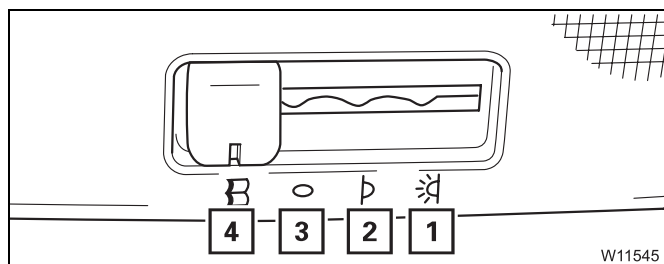

Cab lighting

- 1 On
- 2 On / off via door contact
- 3 Off
- 4 Reading lamp on

3.2.14

Level adjustment system

▶ Operation of the level adjustment system, p. 5 - 65.

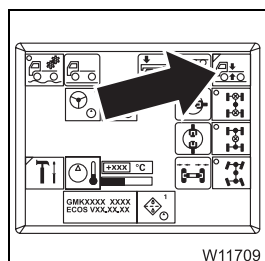

Level adjustment system submenu

- To open: Press button once – submenu opens

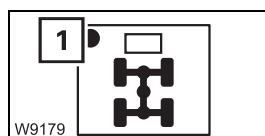

Overall level pre-selection

- **Suspension struts** Press button once – dot (1) green – pre-selection on
 pre-selection: After 5 seconds – dot (1) black – pre-selection off

▶ p. 5 - 66

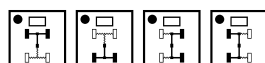

The following functions are operated in the same manner:

- Front level pre-selection
- Rear level pre-selection
- Right level pre-selection
- Left level pre-selection

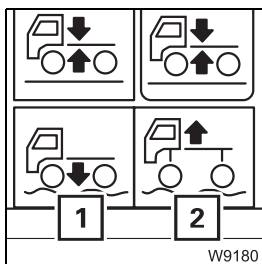

Lowering / raising the level

Suspension struts are pre-selected.

1 To lower: Press button – suspension struts retract

2 To lift: Press button – suspension struts extend

➡ p. 5 - 67

The movement stops after the button is released and when an end position is reached.

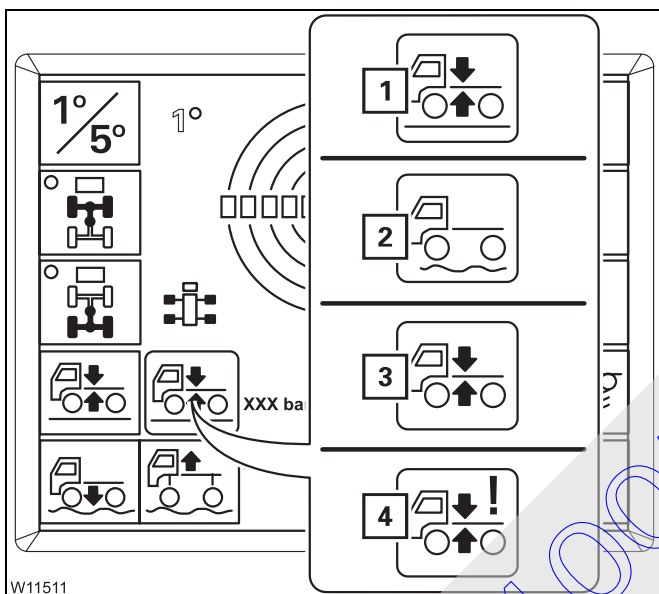

Vehicle level display

The current status is shown using different symbols:

1 Green – on-road level

2 White – no on-road driving level

3 Yellow – level change

4 Violet – error

➡ p. 5 - 65

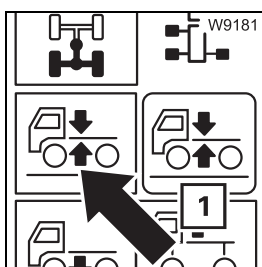

Setting the on-road level

– **To set the on-road level:** Press the button until the symbol (1) is green

➡ p. 5 - 66

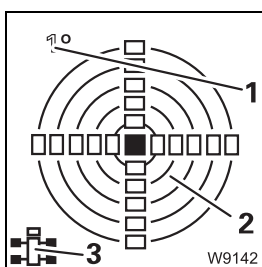

Display of current inclination

1 Measuring range display

2 Inclination display

3 Directional indicator

➡ p. 5 - 67



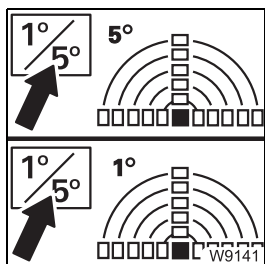

Switching over the measuring range

– **To switch over:** Press button once – the current measuring range 1° or 5° is shown

▶▶ p. 5 - 67

3.2.15

Tachograph / speedometer

Tachograph

Correcting the time

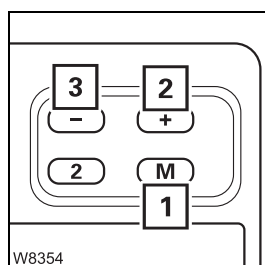

- 1 Open the time menu:** Press the button – the time correction menu opens
- 2 Time correction +:** Press the button – the time is increased
- 3 Time correction –:** Press the button – the time is decreased

Speedometer

Displays the speed and the route:

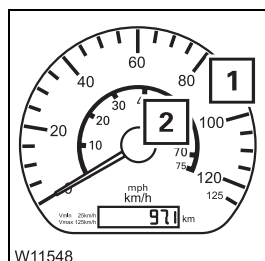

Speed indicator

- 1** Indicates the speed in km/h
- 2** Indicates the speed in mph

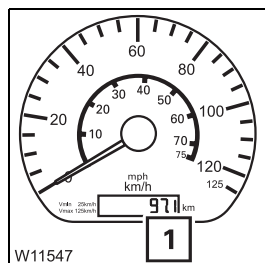

Kilometre counter

The ignition is switched on.

- 1** Overall route in kilometres -
Position after the decimal point: 1 = 100 m (33 ft)

3.2.16 Diagnostics

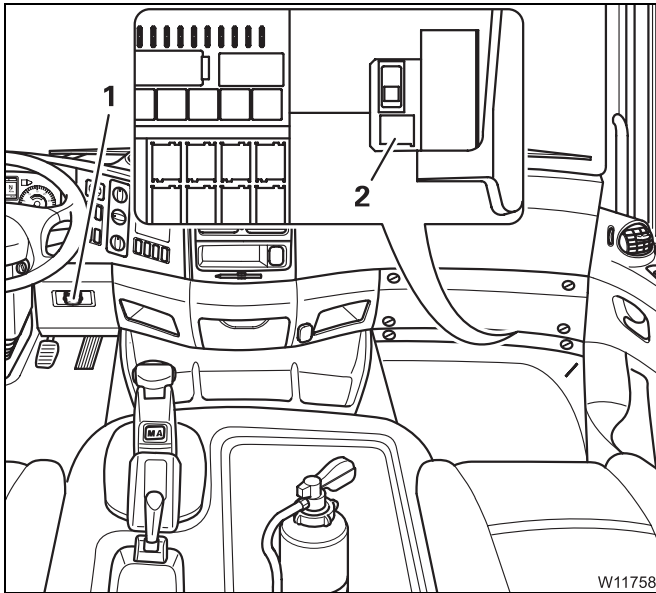

The diagnostics connections may only be operated by service staff from the engine transmission manufacturer, or by **CraneCARE**.

- 1 Engine / transmission diagnostics
- 2 ECOS diagnostics

Displays / submenu

Settings submenu

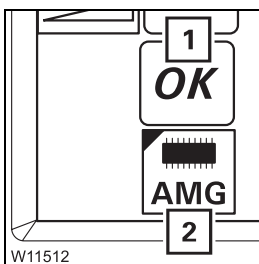

- 1 **AMG diagnostics**
OK, STOP or the service symbol (spanner) is displayed, depending on the degree of the error.
- 2 **Diagnostics submenu**
If there is a malfunction, press button (2) once, read the values in the submenu and report to **CraneCARE**.

Further displays are shown on the *Driving* display; *Diagnostics*, p. 5 - 26.

3.2.17 On-board computer

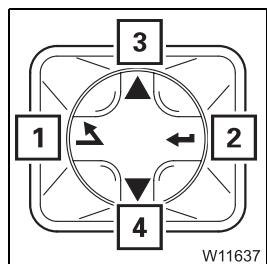

Operating the on-board computer

On the *On-board computer* display:

- 1 Quit menu, acknowledge
- 2 Select menu, confirm entry
- 3 Up
- 4 Down

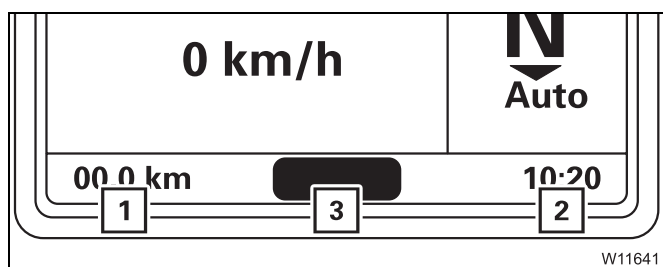

Information status display

- 1 Day's kilometre counter
- 2 Time
- 3 Depending on the setting
 - Alarm clock; p. 5 - 24
 - Tempomat; p. 5 - 41
 - Temposet; p. 5 - 43

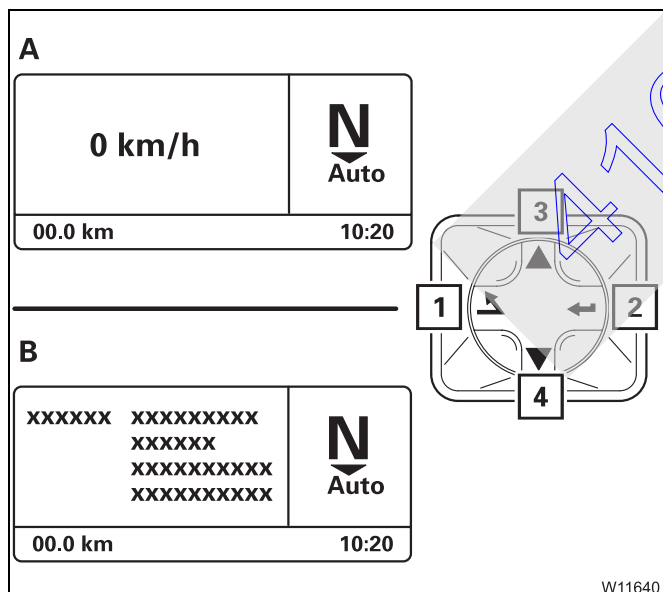

On-board computer display

Manual displays:

- A** Can be retrieved with (3), (4):
 - Display speed
 - Display date
 - Display tank volume / range of coverage
 - Display audio
 - Display journey data; p. 3 - 55
- B** Can be retrieved with (1):
 - Display menus; p. 5 - 22

When ignition off / on, the last set display is shown.

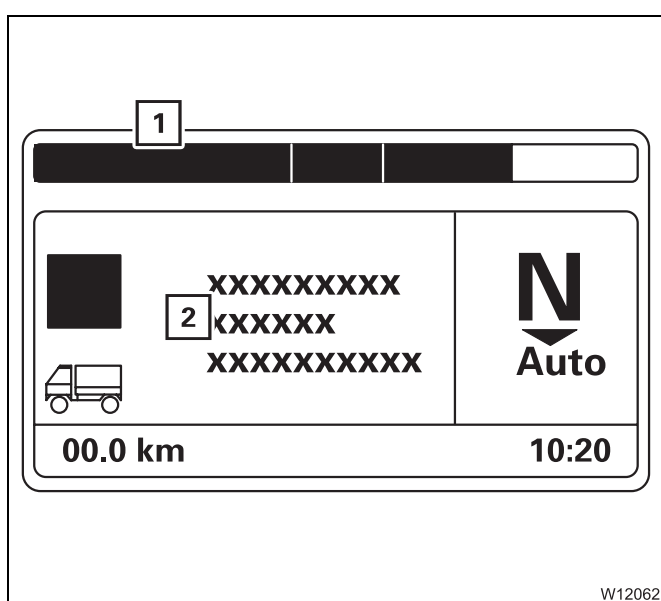

Automatic displays:

1 Status display

- Red – warning message, action required immediately
- Yellow – error message / information, action required imminently

▬▬▬ p. 5 - 50

2 Messages; ▬▬▬ p. 5 - 50

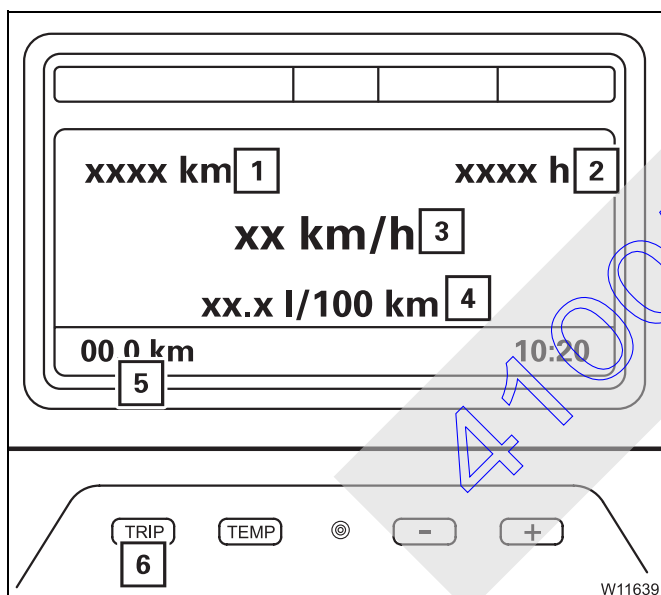

Show journey data / reset

- Reset

Keep the button (6) held down for approx. 1 second, displays (1) to (5) are shown; 0 = start of journey.

- Displays

All values apply from the start of the journey

- 1 Journey route
- 2 Journey duration
- 3 Journey speed – average
- 4 Current consumption
- 5 Day's kilometre counter

3.2.18 Push-up roof

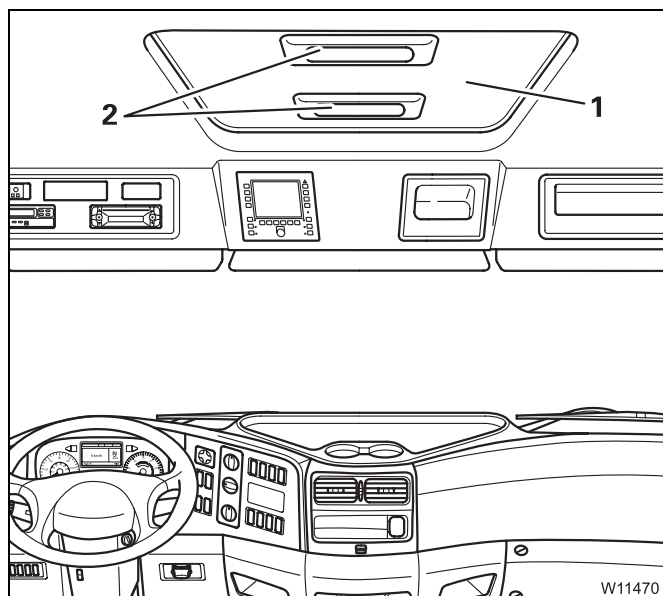

Open

Hold the push-up roof (1) by the handles (2) and push up into the required position.

Closing

Hold the push-up roof by the handles (2) and pull down until it latches into place.

3.2.19 Windows, doors, keys

Window winder



Risk of crushing when closing the windows

If the window winders encounter resistance, they do not stop but keep on moving at reduced power.

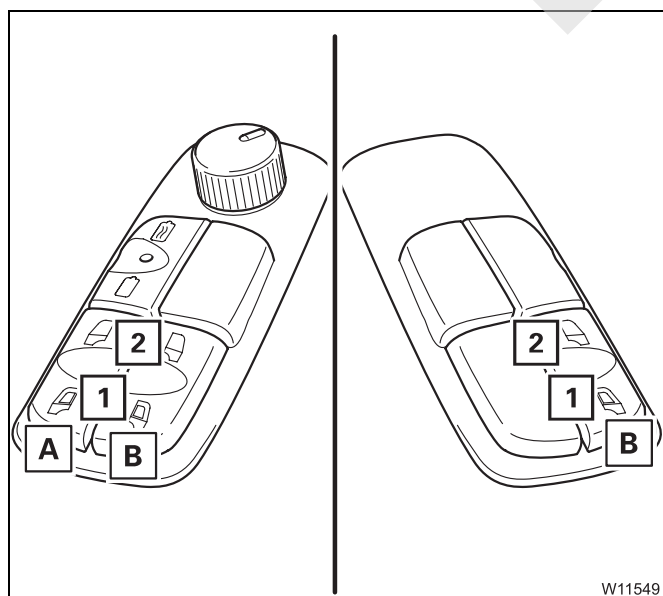

Button assignment

- A Window winder, driver's door
- B Window winder, passenger door
- 1 To open the window
- 2 To close the window

The movement stops after the button is released and when an end position is reached

Doors

The same key is used for the driver's and passenger's door.

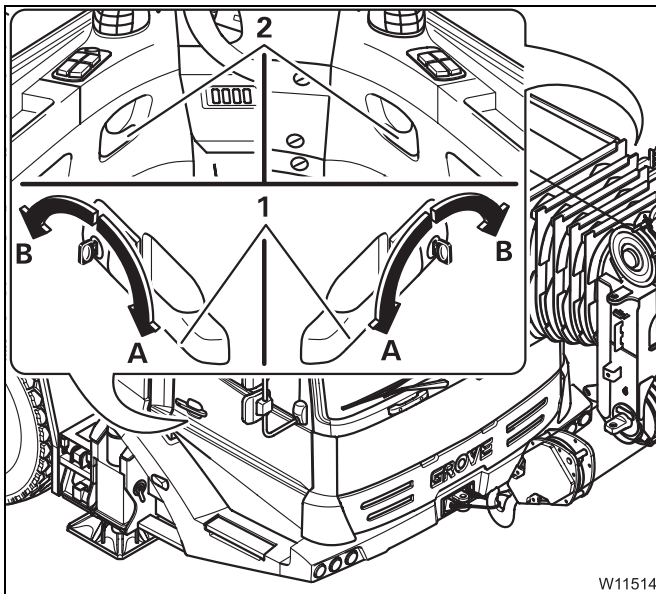

W11514

Lock

- Turn the key in the **B**, or
- Press in the handle (**2**)

Unlock

- Turn the key in the **A**, or
- Pull the handle (**2**)

Open

- Pull the handle (**1**), or
- Pull the handle (**2**)

Keys

Different keys are supplied.

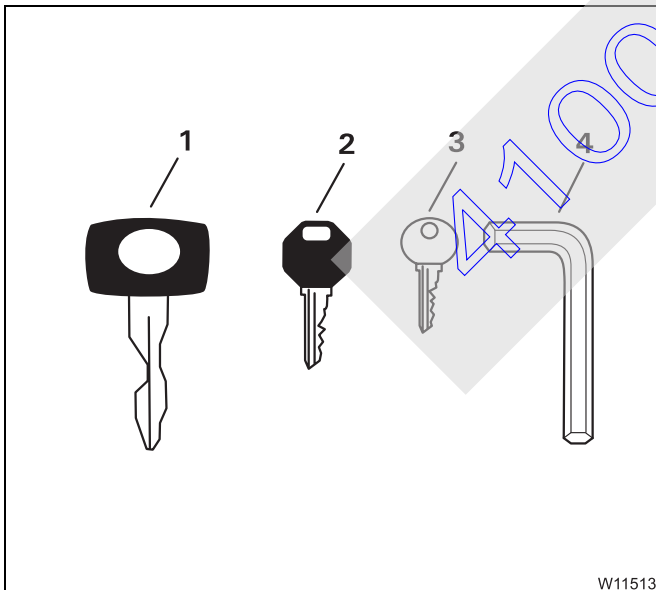

W11513

- 1 Door locks / ignition lock of driver's cab
- 2 Control unit, outriggers¹⁾
- 3 Fuel tank¹⁾
- 4 Covers

¹⁾ Additional equipment

3.2.20

Front flap

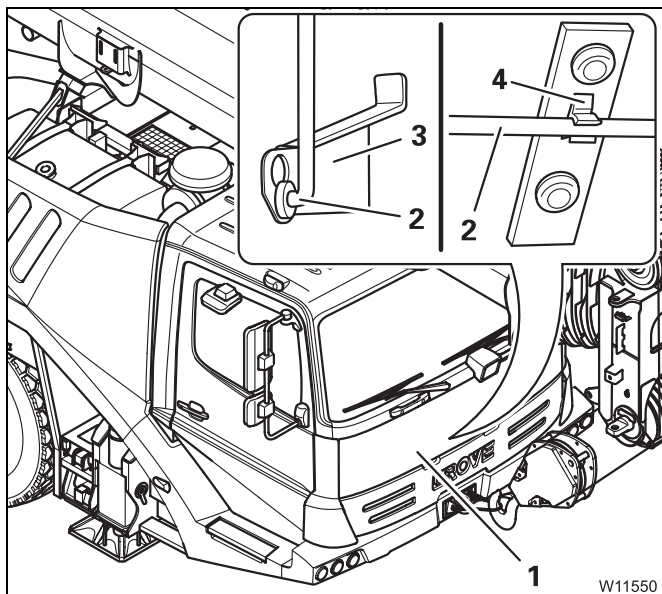

Open

- Fold up the front flap (1)
- Fasten the support (2) in the clamp (3)

Closing

- Lift the front flap (1)
- Fasten the support (2) in the clamp (4)
- Fold down the front flap
- Press the front flap against the driver's cab until you can hear it latch into place

3.2.21

Storage compartment

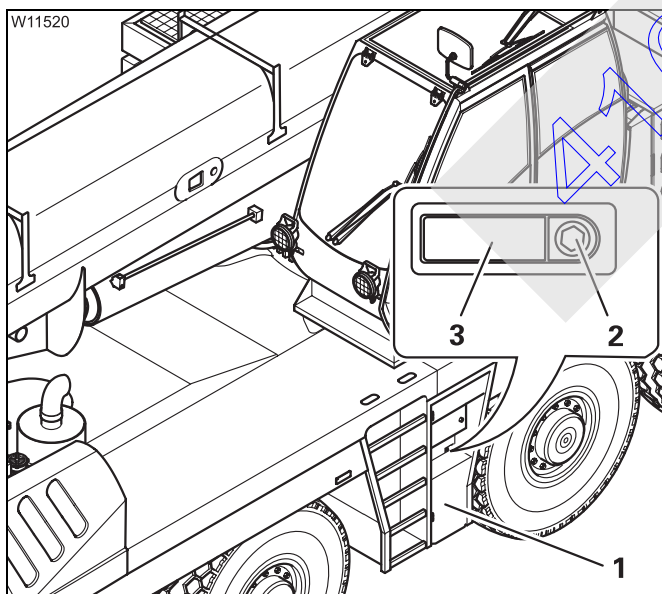

The procedure is the same for all storage compartments.

Opening

- Unlock if necessary.
- Press the button (2) – the door (1) opens.

Closing

- Press the door inwards (1) and press the lever (3) – latches into place.
- Lock if necessary.

4 Starting / turning off the engine for driving

4.1	Starting the engine from the driver's cab	4 - 1
4.1.1	CHECKLIST: Starting the engine	4 - 1
4.1.2	CHECKLIST: if the temperature is low.	4 - 4
4.1.3	Ladders and access ladders	4 - 5
4.1.4	Refuelling.	4 - 7
4.1.5	Checks before starting the engine.	4 - 8
4.1.6	Switching on the ignition.	4 - 9
4.1.7	Lamp test / equalisation of the switching states	4 - 10
4.1.8	Display – setting the brightness	4 - 12
4.1.9	To start the engine	4 - 13
4.1.10	Checks after starting the engine	4 - 16
4.1.11	Control elements.	4 - 17
4.1.12	Setting the idling speed	4 - 19
4.2	Turning off the engine	4 - 21
4.2.1	On the ignition lock / with hand-held control	4 - 21
4.2.2	With emergency stop switches	4 - 22
4.3	Air intake inhibitor	4 - 23

41005067

41005067

4

Starting / turning off the engine for driving

4.1

Starting the engine from the driver's cab

This section describes how to start the engine from within the driver's cab. You can also start the engine using the hand-held control, or from the crane cab; ■■■► *Starting the engine for driving for rigging work*, p. 13 - 21.

4.1.1

CHECKLIST: Starting the engine



This checklist is not a complete set of operating instructions. There are accompanying operating instructions which are referred to by cross-references.

Observe the warnings and safety instructions specified there.

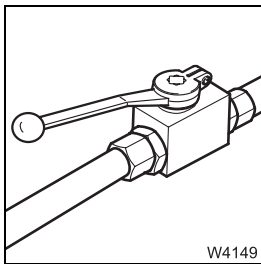

1. Check that the valves on the hydraulic tank are open; ■■■► p. 4 - 8.

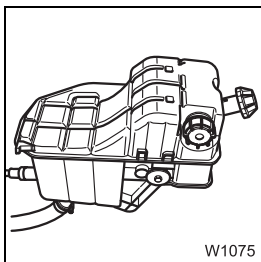

2. Check the coolant level of the engine; ■■■► *Maintenance manual*.

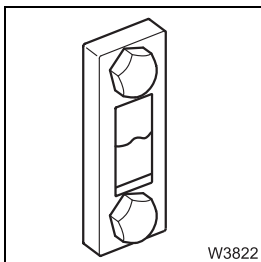

3. Check the oil level in the hydraulic system; ■■■► *Maintenance manual*.



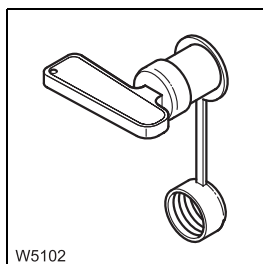

4. Switch on the battery master switch; p. 4 - 8.

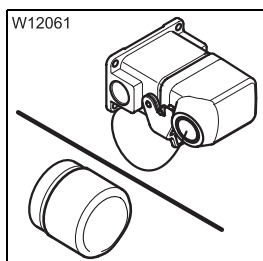

5. Check that
– the bridging plugs are inserted in the sockets for hand-held control;
 p. 11 - 8.
– all emergency stop switches have been reset; p. 4 - 22.

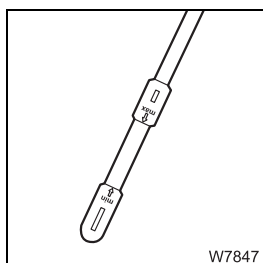

6. Check the oil level in the engine; *Maintenance manual*.

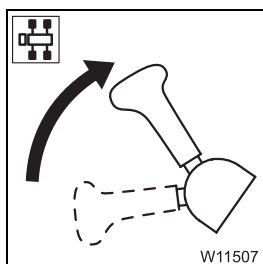

7. Check that the parking brake is engaged.

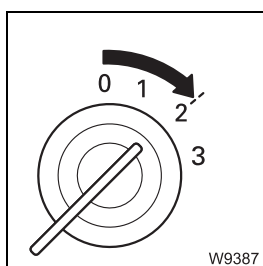

8. Switch on the ignition and check the instruments and displays;
 p. 4 - 9.

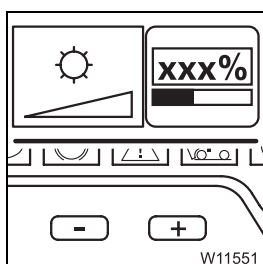

9. If necessary, set the brightness
– on the *ECOS* display; p. 4 - 12
– Instrument lighting; p. 3 - 50.

41005067

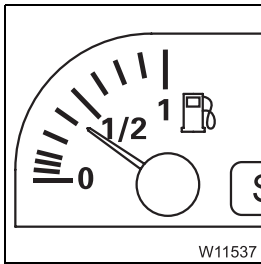

10. Check the fuel reserve; p. 4 - 7.

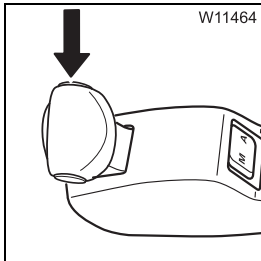

11. Switch the transmission to neutral position; p. 5 - 30.

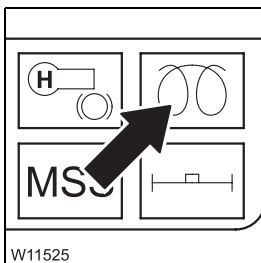

12. If the truck crane has a flame start system, wait until the lamp goes out; p. 4 - 15.

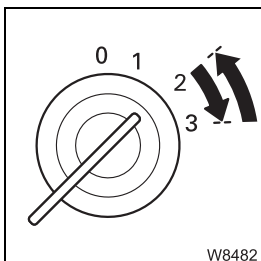

13. Start the engine; p. 4 - 13.

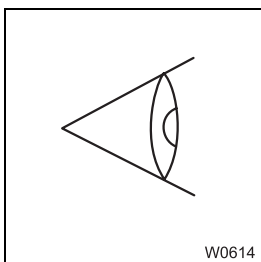

14. Conduct the necessary checks after starting the engine; p. 4 - 16.

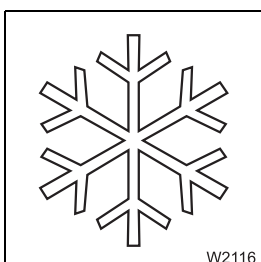

15. In the event of low outside temperatures; *CHECKLIST: if the temperature is low, p. 4 - 4.*

4.1.2

CHECKLIST: if the temperature is low

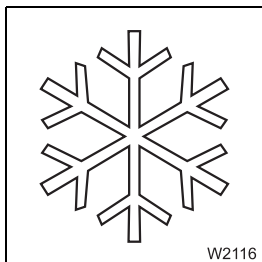

You must also observe the following points when operating the truck crane in low outside temperatures:

1. The fuel and engine oil must be suited for use in the outside temperature in question; ■■■▶ *Separate engine operating instructions, provided by the manufacturer*
2. The engine coolant must contain sufficient antifreeze; ■■■▶ *Separate engine operating instructions, provided by the manufacturer.*
3. The windscreen washing system must contain sufficient antifreeze; ■■■▶ *Windscreen washing system, p. 5 - 6.*

41005067

4.1.3

Ladders and access ladders

Access ladders

The access ladders are firmly attached.

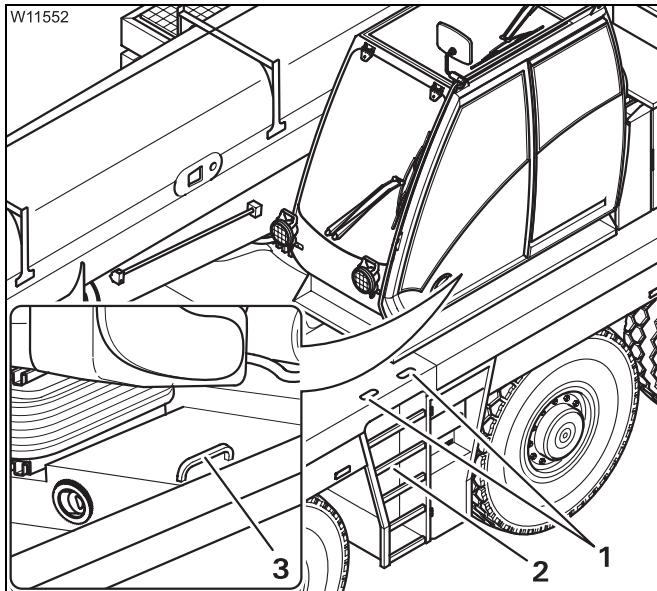

One access ladder is located on each of the two sides (2) with hand holes (1).

When the crane cab door is open, you can also reach the handle (3).

Ladders

There are different ladders on the truck crane.



Risk posed by ladders falling down

Always secure the ladders before driving. This prevents the ladders from falling down while driving and endangering other vehicles.

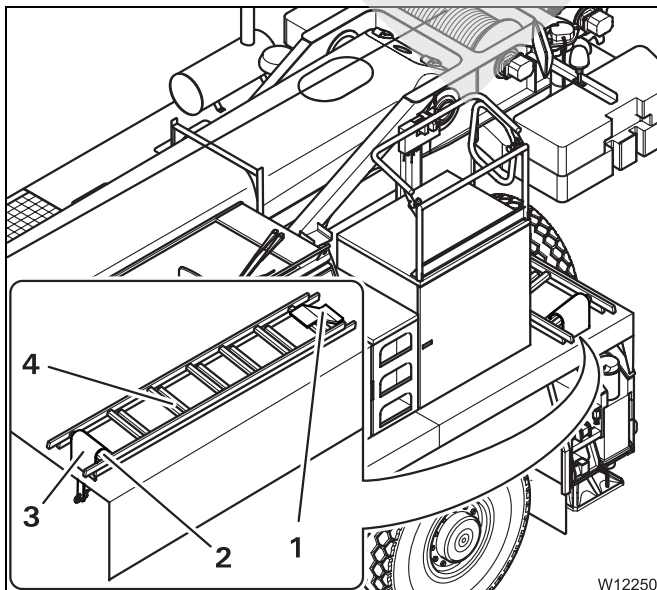

You can push out the ladder (4).

While driving

- Push the ladder (4) into the clamp (1).
- Place the clamp (3) over the rungs (2).
- Secure the clamp (3) from below with a retaining pin or a lock.



Starting / turning off the engine for driving
4.1 Starting the engine from the driver's cab

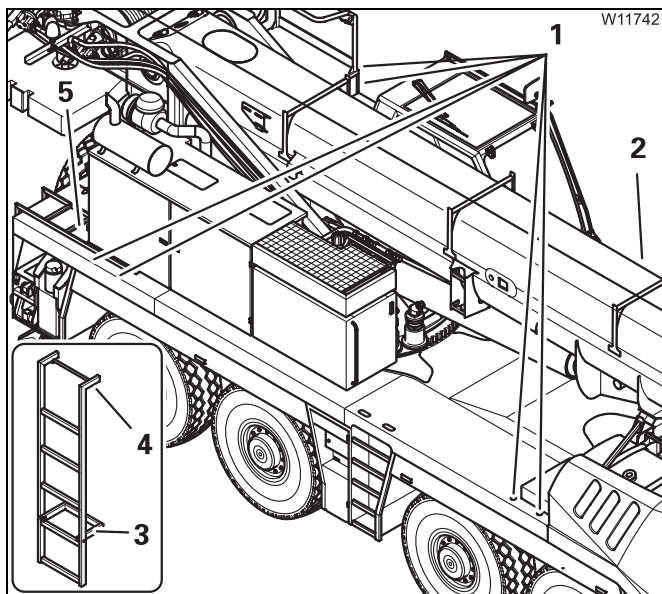

You can attach the ladders (2) and (5) on both sides.

For a safe ascent, both plugs (4) must be inserted into the bores (1) and the holder (3) must be folded out.

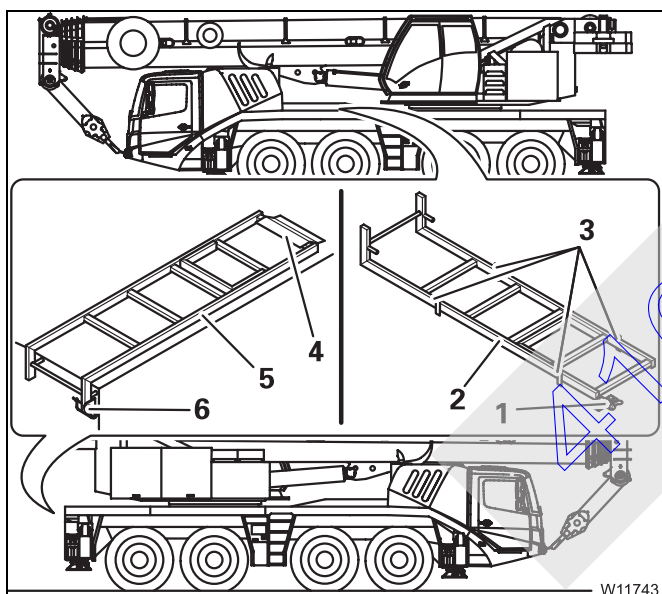

While driving

- Push the ladder (5) under the clamp (4) and secure it with the retaining pin on the clamp (6).
- Place the ladder (2) between the clamp (3) and secure it with the spring latch (1).

4.1.4

Refuelling

Only use permitted fuels;  *Separate engine operating instructions, provided by the manufacturer.*



Danger of fire due to inflammable gases

Switch off the engine, the heater and all additional heating devices before refuelling.

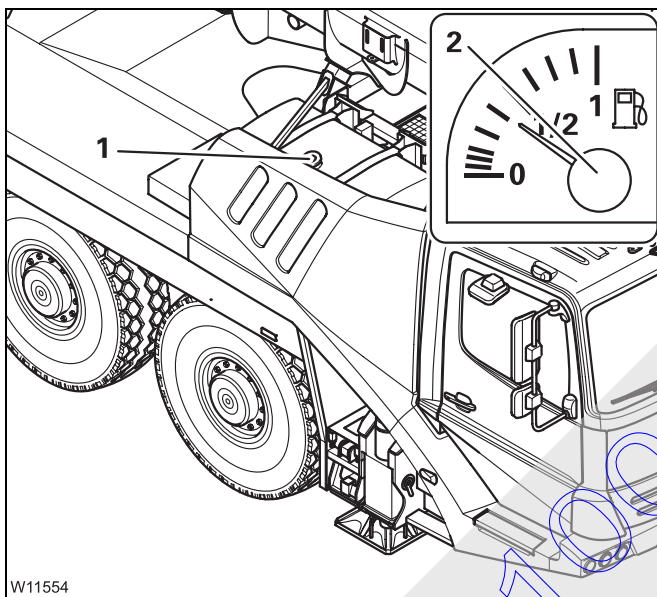

The display (2) shows the fuel supply in the tank (1).

- Refill the fuel in due time, and close the tank (1) with the lid.

W11554



Risk of accidents if the tank is not closed!

Close the tank each time you have refuelled.

In this way you can prevent other vehicles from being endangered by the cap falling off or fuel escaping.

4.1.5

Checks before starting the engine

On the hydraulic tank

Before you start the engine, all valves on the hydraulic tank must be open.



Risk of damage to the hydraulic pumps

You may only start the engine when all the valves on the hydraulic tank are open.

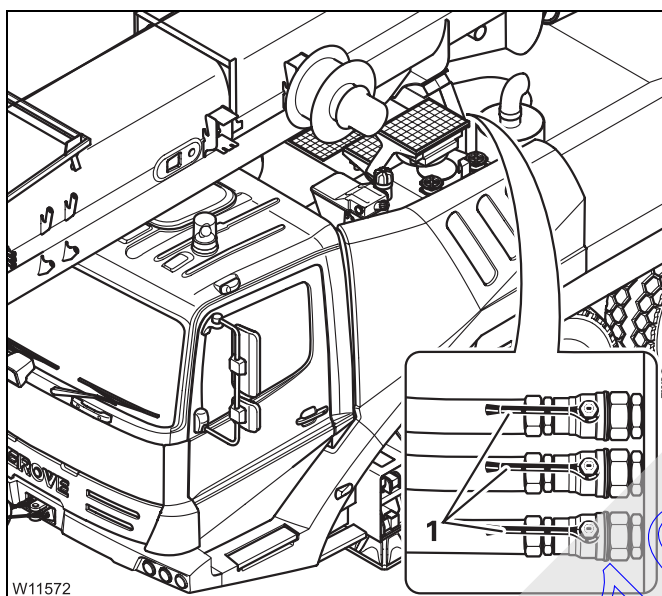

- Check whether the valves are open – lever parallel to the line.
- Open the closed valves.

Battery master switch

You can only start the engine when the battery master switch is switched on.

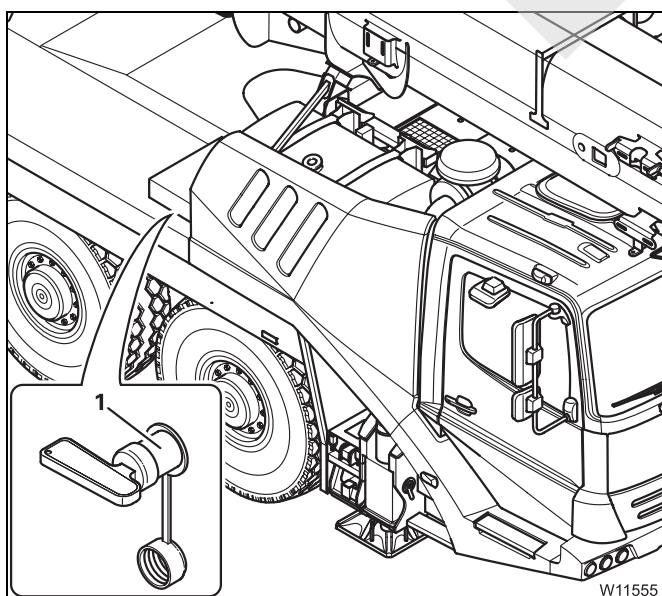

- Switch on the battery master switch (1).
- The battery master switch is switched on if you are unable to pull off the selector handle.

Checking the hand-held control

Check whether the hand-held control has been removed, and that the bridging plugs for the hand-held control are inserted into all sockets;  p. 3 - 26.

4.1.6

Switching on the ignition



The ignition can only be switched on if the bridging plugs have been inserted in all sockets for hand-held control;  *Sockets for hand-held control*, p. 3 - 26.

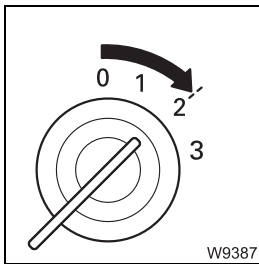

- Insert the ignition key into the ignition lock and turn the key to position **2**.

After switching on the ignition, a lamp test is carried out, and switching states are checked.

41005067

4.1.7

Lamp test / equalisation of the switching states

Lamp test

After the ignition has been switched on, a lamp test is conducted.



Risk of accidents due to faulty lamps

The lamps that are used to provide warnings and information during operation go on for control purposes whenever the ignition is switched on. Always perform the following lamp tests and immediately replace faulty lamps or have them replaced.

In this way, you will avoid accidents and damage that occur when malfunctions are not identified in time.

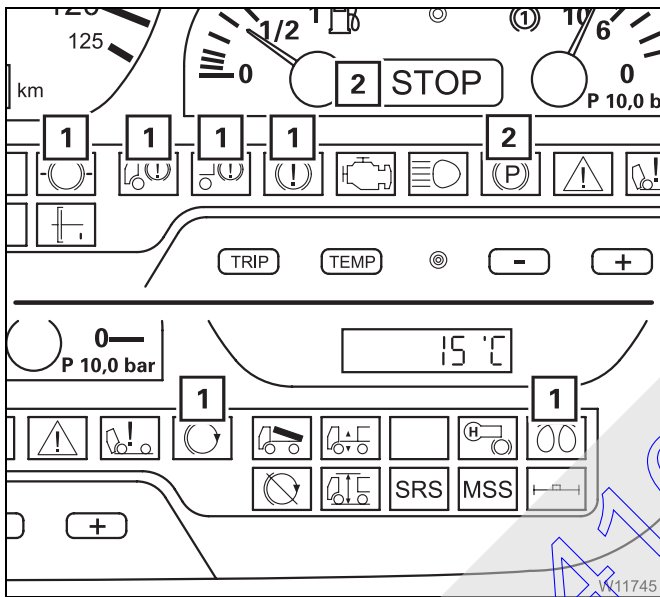

- Check that the lamps (1) light up briefly, if they are present. If the specified time is insufficient, switch on the ignition again.
- If necessary, engage the parking brake and check that the lamps (2) light up continuously.

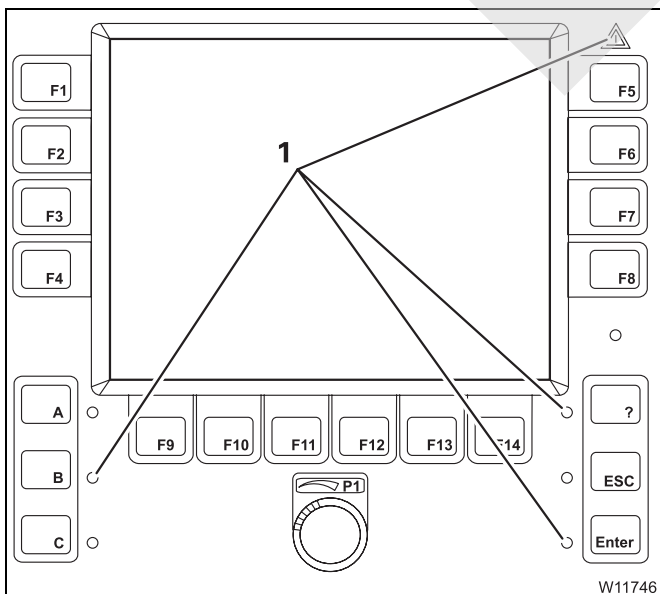

- Check that the lamps go on for about two seconds after switching on the ignition (1):
Contact **CraneCARE** if one or more lamps do not go on.

If you could not check all the lamps in the specified time, you can conduct the lamp test again as follows.

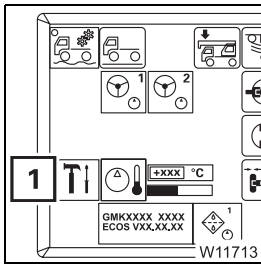

Conducting the lamp test

- If necessary, open the main menu  and press the button (1) once. The *Settings* submenu opens.

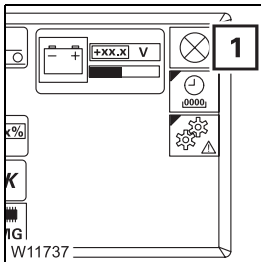

- Press the button (1). The lamps on the ECOS control unit remain lit until you let go of the button again.

If necessary, you can set the minimum brightness of the display;
 p. 4 - 12.

Equalisation of the switching states

When the ignition is switched on, the switching states of the differential locks and the separate steering are compared.

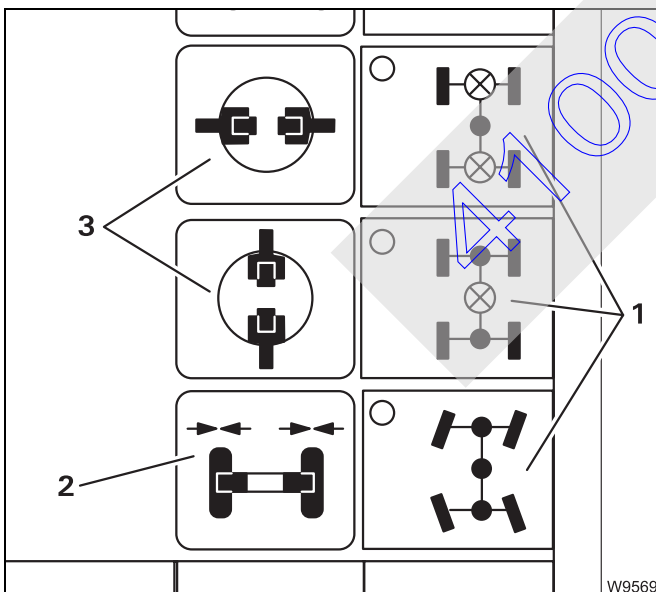

The state last saved is retrieved.

In the main menu, the corresponding symbols (1) are shown and the electronics system triggers the switching operations.

The displays (2) and (3) show the current switching states.

If the display (2) does not show the symbol that corresponds to the switching process, you must actuate the steering so that the locking processes are performed mechanically;
 *Switching to normal steering mode*, p. 5 - 73.

4.1.8 Display – setting the brightness

The brightness of the displays is regulated automatically by the *ECOS*, depending on the ambient brightness. You can set a minimum degree of brightness manually, which is always observed when the brightness is regulated.

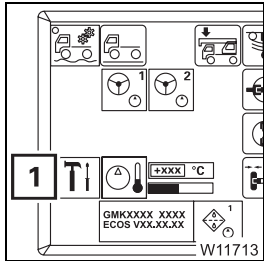

- If necessary, open the main menu  and press the button (1) once. The *Settings* submenu opens.

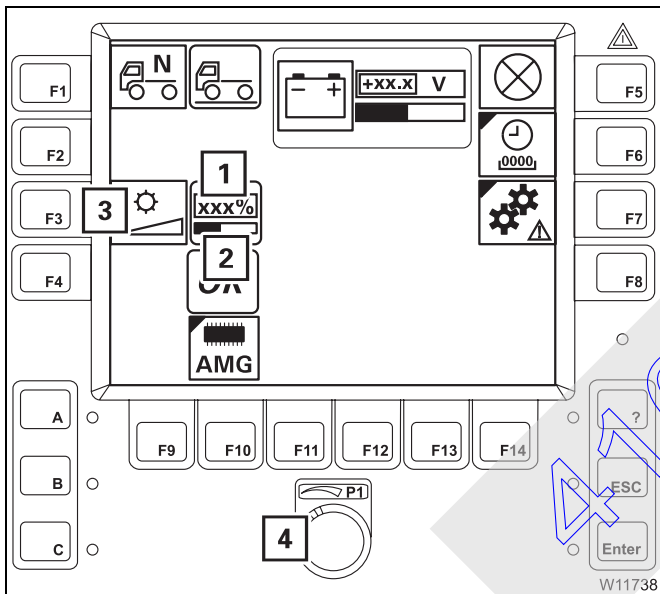

- Press the button (3) once. A red bar (2) appears below the display (1).
- Set the required minimum degree of brightness with the switch (4).

The brightness of the display changes during the setting procedure and you can view the set value (0 to 100%) on the display (1). The degree of brightness which you set here is the minimum value for the automatic regulation.



There is no automatic regulation if you set 100%. The displays are always displayed with maximum brightness.

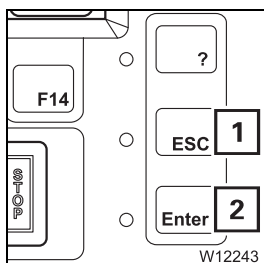

You can interrupt the entry at any time with the button (1). The settings are then reset.

- Adopt the **minimum brightness** entered – press the button (2) once. The red bar below the display goes out. The brightness is automatically regulated between the newly set value and 100%.

4.1.9

To start the engine



This section describes only how to start the engine from the driver's cab. You can also start the engine with the hand-held control; p. 13 - 21.

Refer to the separate operating instructions provided by the engine manufacturer for the operation of the engine. The engine can only be started if

– The bridging plugs have been inserted in all sockets of the carrier and superstructure for the hand-held control; p. 3 - 26

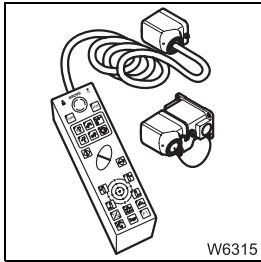

– The transmission is in the neutral position; p. 5 - 30

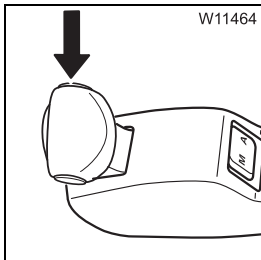

• Check that the parking brake is applied.

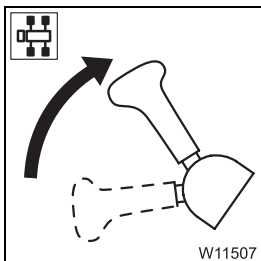

If the engine is equipped with a flame start system; *With flame start system*, p. 4 - 15



**Without flame
start system**

This section applies to starting a warm and a cold engine.



Danger of explosions when using starter fuel

The engine may never be started with the aid of starter fuel. The starter fuel sprayed into the suction unit may ignite.

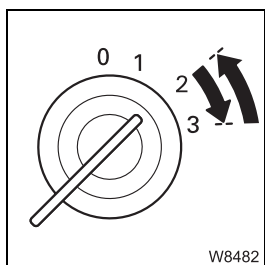

- Do not press the accelerator.
- Turn the ignition key to position **3** and hold it there until the engine goes on.
- Let go of the ignition key after the engine goes on.

If the engine does not go on, abort the starting procedure after about 15 seconds and wait one minute before trying again.



If the engine does not go on after several attempts;  *Malfunctions on the engine, p. 7 - 23.*

41005067

With flame start system

The flame start system warms the suction air of the engine.

This section applies to starting a warm and a cold engine.

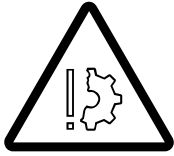

Danger of explosions when using starter fuel

The engine may never be started with the aid of starter fuel. The starter fuel sprayed into the suction unit may ignite.

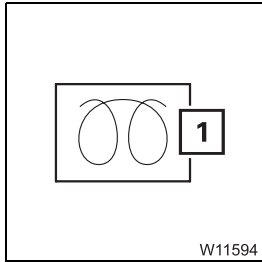

The flame start system is activated each time the ignition is turned on:

- **When the engine is warm**, the lamp (1) will light up only briefly (2 to 3 seconds).
- **When the engine is cold**, the lamp (1) goes out as soon as the engine has been preheated (duration of up to 20 seconds). Start the engine within the next 30 seconds; otherwise, you must switch on the ignition again and wait until the lamp goes out.



If the lamp (1) does not go out, there is a malfunction on the flame start system; *Messages on the on-board computer display*, p. 5 - 50.

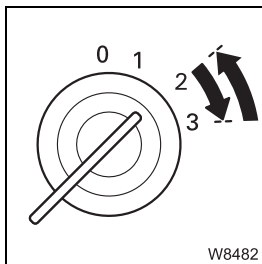

- Wait until the lamp (1) goes out.
- Do not press the accelerator.
- Turn the ignition key to position 3 and hold it there until the engine goes on.
- Let go of the ignition key after the engine goes on.
- If the engine does not go on, abort the starting procedure after about 15 seconds and wait one minute before trying again.



If the engine does not go on after several attempts; *Malfunctions on the engine*, p. 7 - 23.

4.1.10 Checks after starting the engine

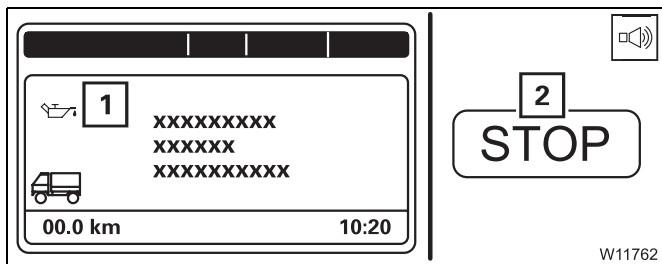

- **Turn off the engine if**
 - The symbol (1) is displayed
 - The lamp (2) lights up and the warning buzzer sounds

If the symbol (1) is displayed, the oil pressure is too low.



Risk of damage to the engine

If the symbol (1) is shown or the lamp **STOP** lights up and the warning buzzer sounds, shut down the engine immediately. The engine can be damaged by running it when the oil pressure is too low.

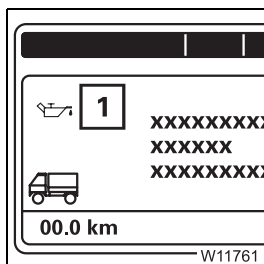

If the symbol (1) or another message is shown; p. 5 - 50.

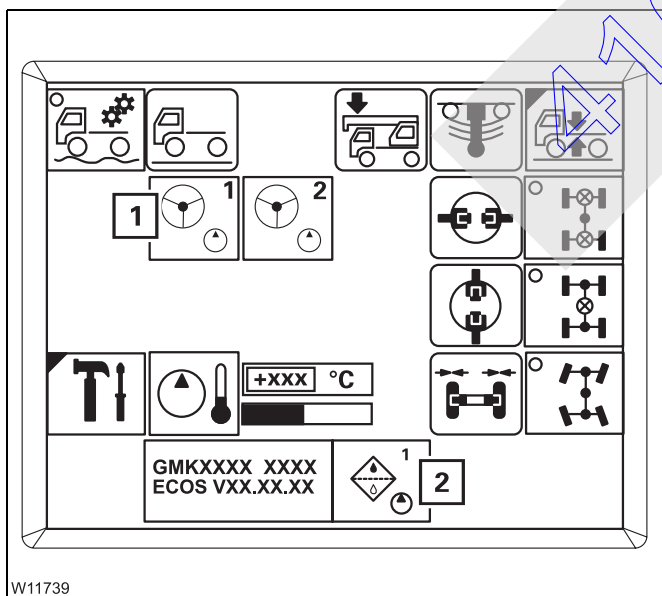

- In the main menu, check the displays (1) and (2):
 - Display (1) – when the symbol is red; *Immediately after you start to move*, p. 5 - 39.
 - Display (2) – when a warning message is shown; *Warning submenu*, p. 5 - 48.

4.1.11

Control elements

Instrument panel

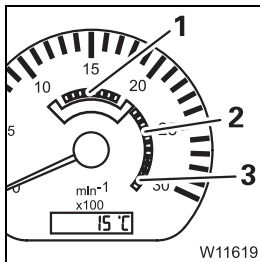

Tachometer

- 1 Green:** appropriate consumption
- 2 Yellow:** engine brake active
- 3 Red:** engine speed to high – danger;
 ▶ *Inspections when driving downhill*, p. 5 - 44

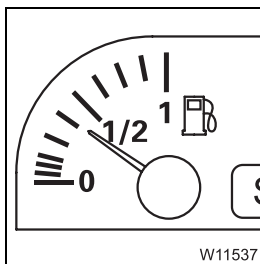

Fuel level display

Never run the fuel tank completely dry; always refuel in due time;
▶ p. 4 - 7.

If the fuel tank is almost empty, air can be sucked in and the fuel system must be bled; ▶ *Maintenance manual*.

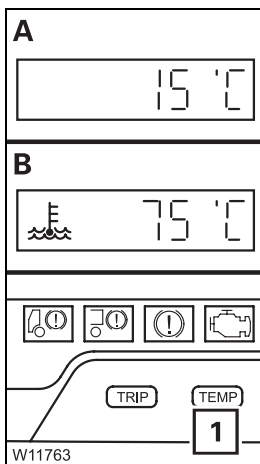

Temperature of the coolant / outside air display

Switch over the display:

- Press the button (1) repeatedly until the desired temperature is shown.

Temperature display.

A: outside air

B: coolant is shown automatically when the limit value is exceeded;
▶ *Messages on the on-board computer display*, p. 5 - 50.

Set the temperature unit (°C / °F); ▶ p. 5 - 25.



ECOS display

The control elements are in the main menu and in the *Settings* submenu.

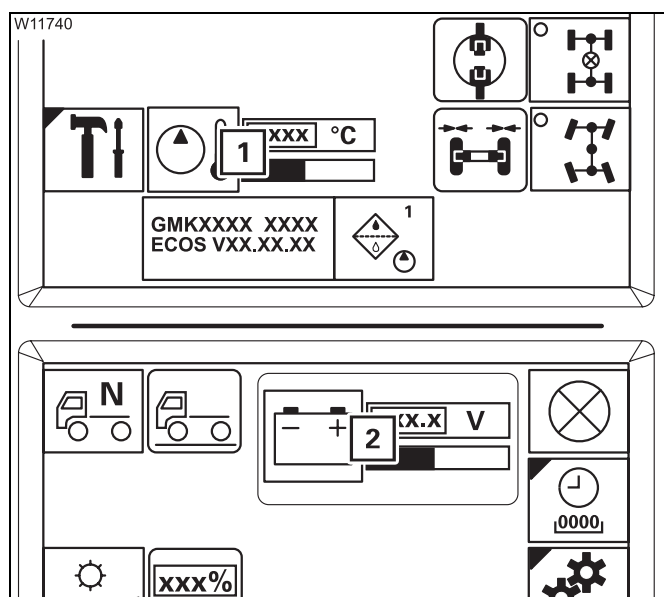

In the main menu

- 1 Hydraulic oil temperature display
– in °C (°F)

In the Settings submenu

- 2 Voltage display
– in Volts

The colour of the bar below the values indicates in which area the value can be found.

- Green:** value o. k.
Yellow: limit value almost reached
Red: limit value exceeded (or fallen short of) – warning message;
 ▣▣▣▣ p. 5 - 48.

Display, driver's cab

▣▣▣▣ *Inspection information*, p. 5 - 23

4.1.12

Setting the idling speed

After the engine is started, the idling speed is regulated automatically. If necessary, you can adjust the idling speed manually using the multipurpose switch.



You can only set the idling speed when the truck crane is stationary.

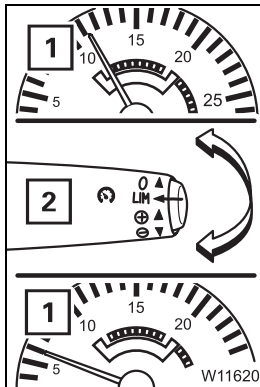

Increasing / reducing the idling speed

- Press the switch (2) up / down until the required engine speed (1) has been reached.
- or
- Press the switch (2) upwards / downwards once. The engine speed (1) is increased / reduced by 20 rpm.

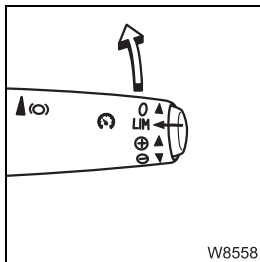

Switching off the idling speed change:

- Push the switch forwards once. The idling speed is set automatically.
- or
- Accelerate over 20 km/h (12 mph).

Blank page

41005067

4.2

Turning off the engine

4.2.1

On the ignition lock / with hand-held control



Risk of accidents due to the fact that the truck crane cannot be steered
Only turn off the engine once the truck crane is at a standstill. If you remove the ignition key, the steering will lock and you will lose control of the moving truck crane.

If the temperature of the coolant is very high, let the engine run for another one or two minutes at increased idling speed.

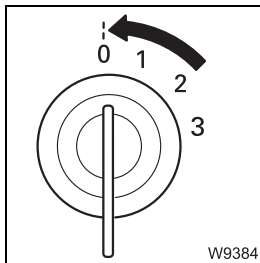

If the hand-held control is not connected:

- Turn the ignition key to position **0** – the engine will stop.

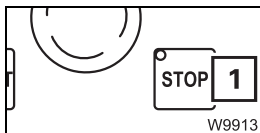

If the hand-held control is connected:

- Press the button **(1)** once – the engine goes off.

In this case it is not possible to switch off the engine with the ignition lock.

After turning off

- If you want to park the truck crane; p. 5 - 58.

4.2.2 With emergency stop switches

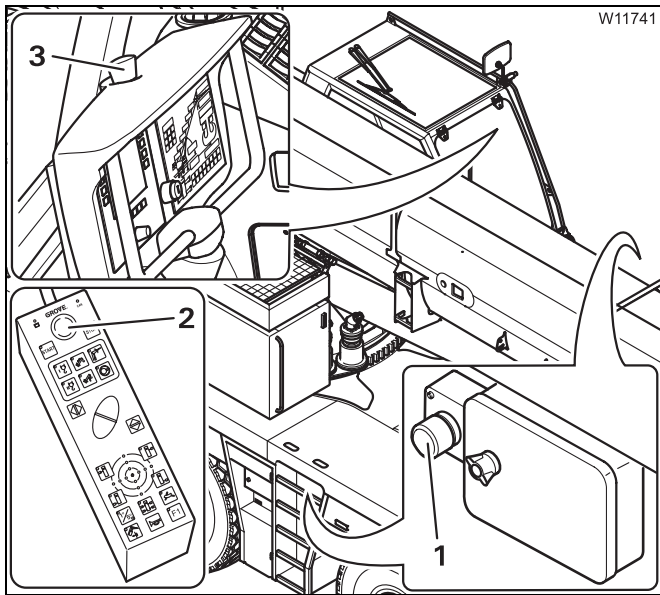

Emergency stop switch

Four emergency stop switches are provided for an emergency:

- 1 On the carrier
- 2 On the hand-held control
- 3 In the crane cab

- Press one of the emergency switches (1), (2) or (3). The switch engages.

The engine goes out.



If an air intake inhibitor is present, it will be triggered – this also applies to the engine for crane operation.

Resetting the emergency stop switch

You can only restart the engine after you have reset the emergency stop switch.

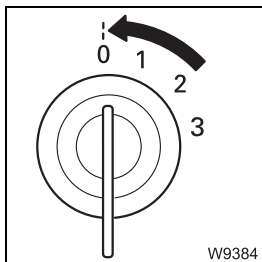

- Turn off the ignition.

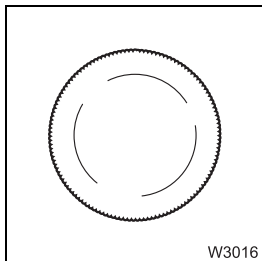

- Turn the actuated emergency-stop switch until it disengages again.

If air intake inhibitors are fitted, they must be released;

- ▣▣▣▣ *Releasing the air intake inhibitor*, p. 4 - 23.
- ▣▣▣▣ *Releasing the air intake inhibitor*, p. 11 - 21.

4.3

Air intake inhibitor

If the air intake inhibitor is triggered, a flap in the air intake line will close and the engine will stop running. The air intake inhibitor is triggered

- If an emergency stop switch is actuated or
- when the maximum permissible engine speed is exceeded. In this case, the symbol (1) will turn **red** – at the *Warning* display and in the *Warning* submenu. The symbol stays red until the ignition has been turned off.

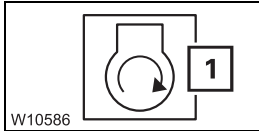

The engine can only be restarted after the air intake inhibitor has been released.

Releasing the air intake inhibitor

The following requirements must be met in order to release the air intake inhibitor:

- The ignition is switched off
- The emergency-stop switch is reset

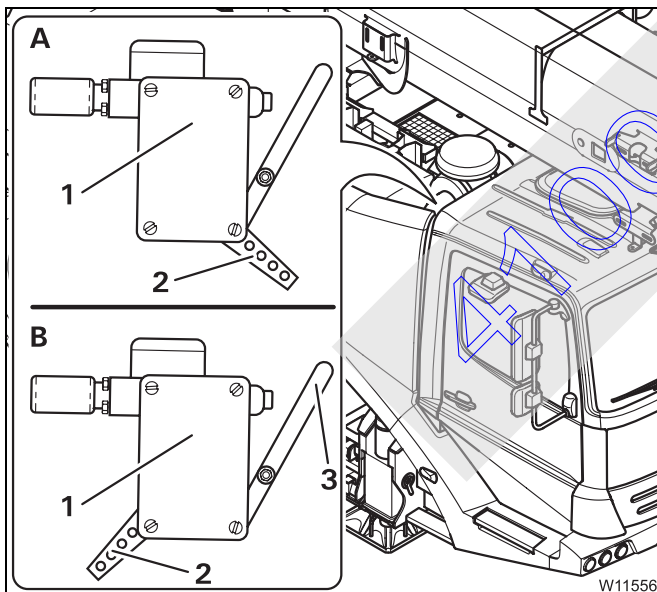

The indicator (2) shows the current state of the air intake inhibitor (1).

(A) – The indicator (2) is in the *closed* position.

(B) – Turn the indicator (2) clockwise until it engages into the *Released* position.

You can close the air intake inhibitor manually with the lever (3).

Blank page

41005067

5 Driving

5.1	Before driving	5 - 1
5.1.1	CHECKLIST: inspections before on-road driving	5 - 1
5.1.2	Checking the condition of the truck crane	5 - 6
5.1.3	Adjusting the seats and steering column	5 - 11
5.1.4	Switching the suspension on / off	5 - 14
5.1.5	Adjusting the tachograph	5 - 16
5.1.6	Displaying the operating hours	5 - 21
5.1.7	Settings / displays with the on-board computer	5 - 22
5.2	Operating the transmission	5 - 29
5.2.1	Switching on	5 - 29
5.2.2	Switching the transmission to neutral position	5 - 30
5.2.3	Changing the operating mode	5 - 30
5.2.4	Display of the selected gears	5 - 31
5.2.5	Selecting the direction of travel and starting gear	5 - 31
5.2.6	Starting	5 - 33
5.2.7	Driving and changing gears	5 - 34
5.2.8	Changing the driving direction	5 - 36
5.2.9	Stopping	5 - 37
5.2.10	On the roller type dynamometer	5 - 37
5.3	Driving and turning off the truck crane	5 - 39
5.3.1	Inspections while driving	5 - 39
5.3.2	Tempomat	5 - 41
5.3.3	Temposet	5 - 43
5.3.4	Driving downhill	5 - 44
5.3.5	Driving uphill	5 - 47
5.3.6	Warning submenu	5 - 48
5.3.7	Error submenu	5 - 50
5.3.8	Messages on the on-board computer display	5 - 50
5.3.9	Turning off the truck crane	5 - 58
5.4	Off-road driving	5 - 61
5.4.1	Transfer case – off-road gear on / off	5 - 62
5.4.2	Longitudinal and transverse differential locks	5 - 63
5.4.3	Operation of the level adjustment system	5 - 65
5.4.4	Freeing the truck crane stuck in terrain	5 - 69
5.4.5	Separate steering	5 - 71
5.5	Heating and air-conditioning system	5 - 75
5.5.1	Standard heating system	5 - 75
5.5.2	Air-conditioning system	5 - 78
5.5.3	Auxiliary heater	5 - 80
5.6	Towing a trailer	5 - 85

41005067

5 Driving

5.1 Before driving

5.1.1 CHECKLIST: inspections before on-road driving



This checklist is not a complete set of operating instructions. There are accompanying operating instructions which are referred to by cross-references.

Observe the warnings and safety instructions specified there.

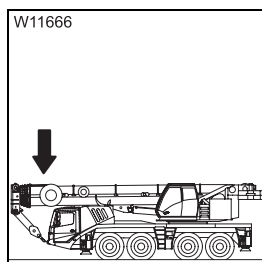

1. If the boom is on the boom rest

- All telescopic sections are interlocked; the telescoping cylinder is locked with telescopic section 1
- The slewing gear is switched off; ■■■▶ p. 12 - 92,
- The symbol (1) is displayed (if present); ■■■▶ p. 5 - 8.



2. When the main boom is resting on a trailer

- All telescopic sections are locked
- The slewing gear is switched off; ■■■▶ p. 12 - 92,
- The boom floating position is switched on; ■■■▶ p. 6 - 9
- The slewing gear freewheel is switched on; ■■■▶ p. 6 - 8
- The boom pre-tensioning may be switched on; ■■■▶ p. 6 - 10
- The houselock may be switched off; ■■■▶ p. 12 - 14

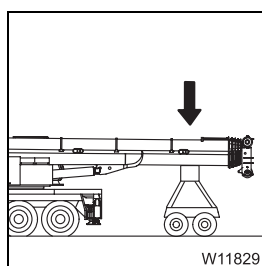

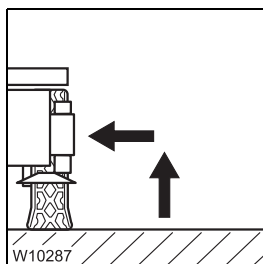

3. On the outriggers

- All outriggers are fully retracted and secured to prevent extension
 ■■■▶ p. 13 - 31.
- The outrigger pads are in the driving position ■■■▶ p. 13 - 38.

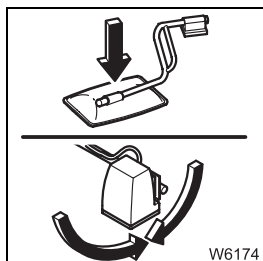

- 4. All mirrors for crane operation are folded in / removed; ■■■▶ p. 13 - 114.**
 The spotlight is turned downwards (if present); ■■■▶ p. 12 - 100.

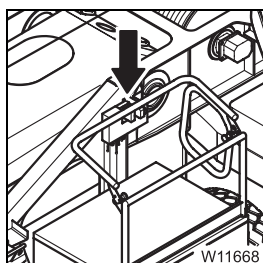

- 5. The railing on the turntable is folded in; ■■■▶ p. 13 - 113.**

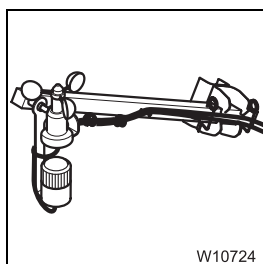

- 6. The anemometer and air traffic control light are removed;**
 ■■■▶ *Anemometer and air traffic control light*, p. 13 - 108.

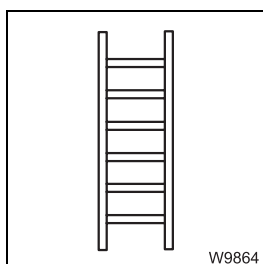

- 7. All ladders are secured; ■■■▶ *Ladders*, p. 4 - 5.**

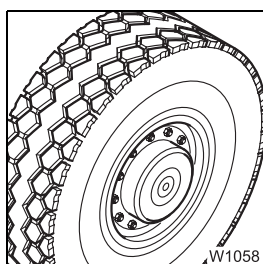

8. Check the tyres:

- tyre pressure when tyres are cold in on-road mode; ■■■▶ p. 8 - 5.
- Further checks; ■■■▶ *Maintenance manual*.

41005067

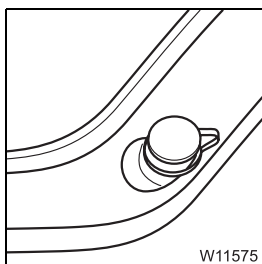

9. Windscreen washing system – check filling level; p. 5 - 6.

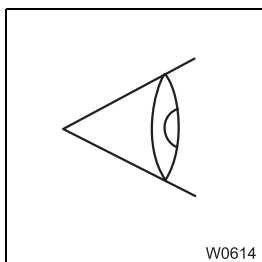

10. Carry out an inspection of the truck crane, looking out in particular for any leaking fluids (oil, fuel or water).

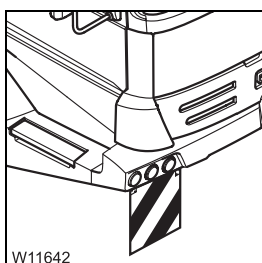

11. The warning signs for marking the vehicle width are folded down (only for vehicle widths of over 2.75 m (9.0 ft));
Vehicle width; p. 8 - 2.
Warning signs; p. 5 - 6.

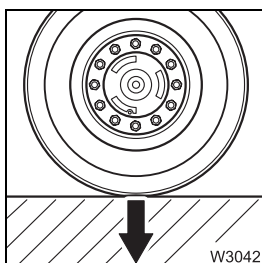

12. The detachable equipment parts are stripped down so that they fulfil the regulations of the country in which you are working as regards permissible weights and axle loads, lengths, widths, height etc.
For a driving mode with a maximum axle load of 12 t (26500 lbs);
 Driving modes, p. 6 - 1.

13. All additional parts which may be transported are secured against falling down.

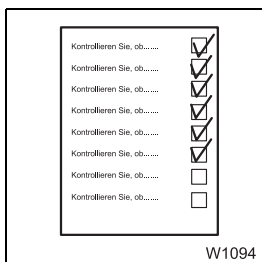

14. Carry out all activities and inspections required for starting the engine;
 CHECKLIST: Starting the engine, p. 4 - 1.



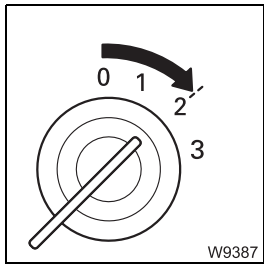

15. Switch on the ignition; p. 4 - 9.

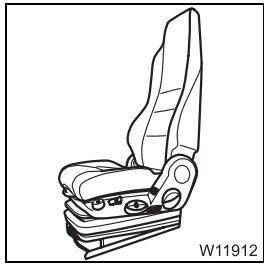

16. Adjust the driver's seat; p. 5 - 11.

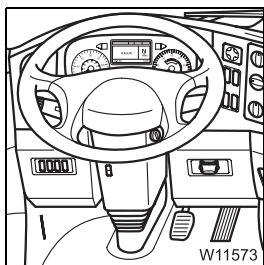

17. Adjust the steering column; p. 5 - 13.

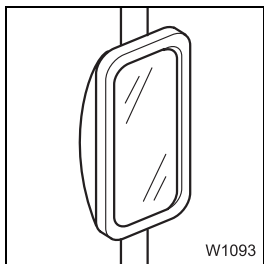

18. Adjust the mirrors; p. 5 - 7.

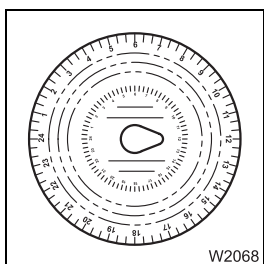

19. Set the tachograph, insert the diagram sheet; p. 5 - 16.

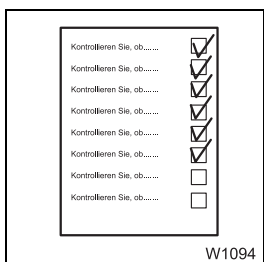

20. Start the engine and carry out all inspections; *Checks after starting the engine*, p. 4 - 16.

47005067



21. Check the electrical system; p. 5 - 6.

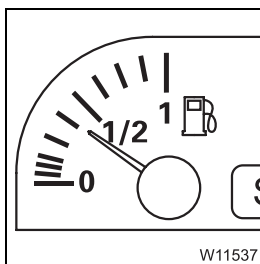

22. Check the fuel reserve; *Refuelling*, p. 4 - 7.

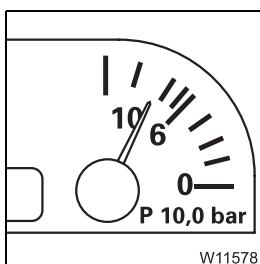

23. Check the compressed air and brake systems; p. 5 - 9.

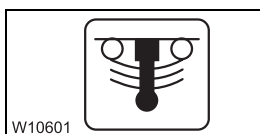

W10601

24. Check that all switching states for on-road driving are set, and that the corresponding symbols are shown:

– Suspension switched on; p. 5 - 15

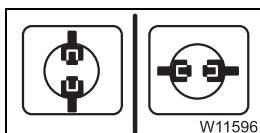

W11596

– Longitudinal and transverse differential locks switched off;
 p. 5 - 63

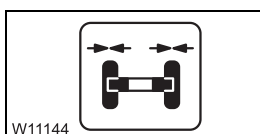

W11144

– Steering locked; p. 5 - 73

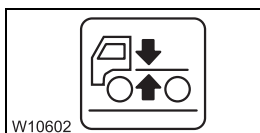

W10602

– On-road level is set; p. 5 - 66

Establish the switching states for on-road driving if necessary.

5.1.2 Checking the condition of the truck crane

Windscreen washing system

Use a windscreen washing agent and, at low temperatures, an appropriate antifreeze.

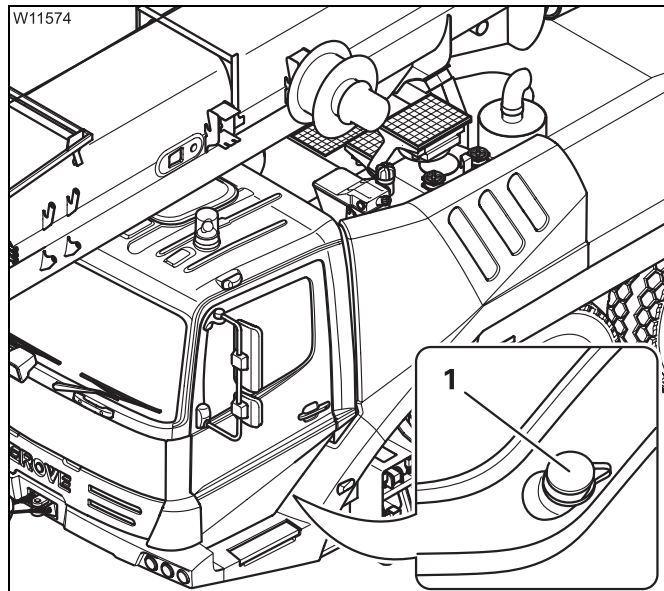

- Open the driver's door.
- Check the level in the tank (1).
- Top up water in due time, and close the tank (1) with the cap.

Electrical system

- Check the following functions and arrange for faulty parts to be repaired:
 - Parking light / headlight, rotating beacons, fog tail light, side marker lights
 - Hazard warning system
 - Brake lights
 - Reversing lamp / buzzer
 - Full-beam headlight
 - Turn signal indicator
 - Windscreen wipers
 - Windscreen washing system
 - Horn

Adjusting the mirrors

Adjust all the mirrors according to your sitting position.

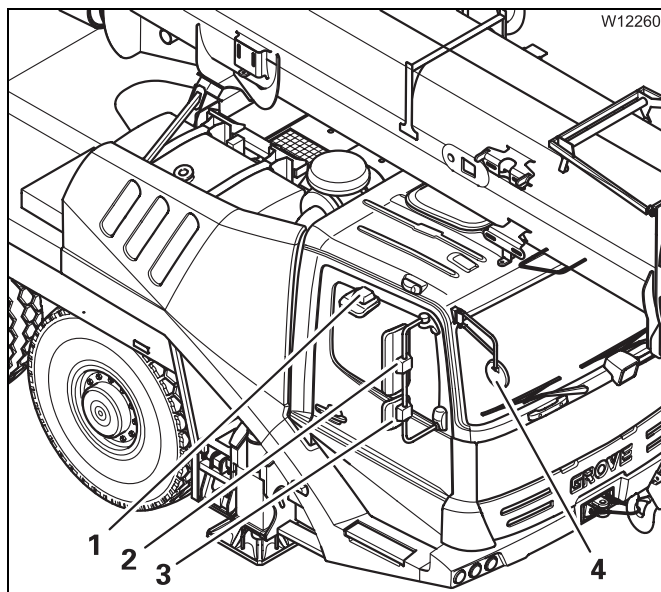

Manual adjustment

- Adjust the mirrors (1), (3) and (4) manually.

The mirrors (2) are adjusted electrically on both sides.

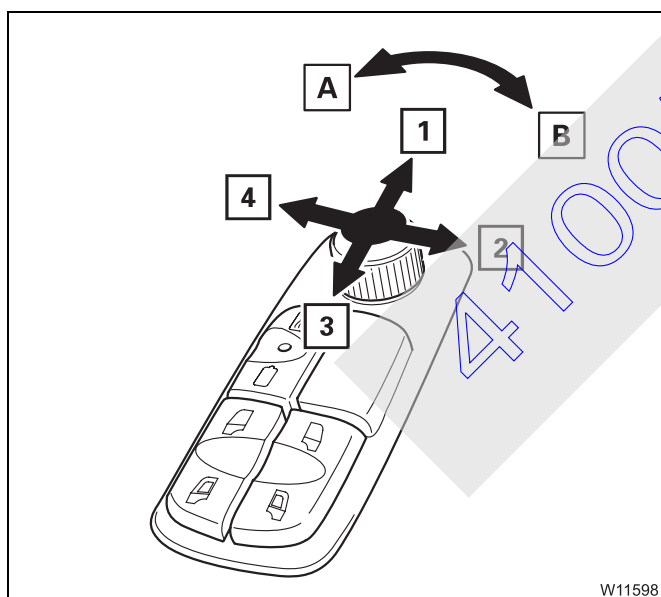

Electrical adjustment

- Turn the button to position
 - A Mirror on the driver's side or
 - B Mirror on the passenger side.
- Press the button – the mirror moves accordingly.
 - 1 above
 - 2 right
 - 3 below
 - 4 left

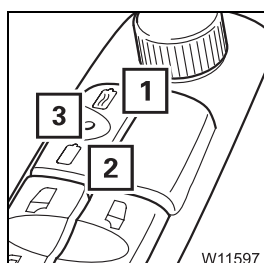

Mirror heating

- 1 To switch on: Press button once – lamp (3) lights up
- 2 To switch off: Press button once – lamp (3) goes out



Warning plates for vehicle width

Depending on the vehicle width, fold-up warning plates have been fitted below the driver's cab.

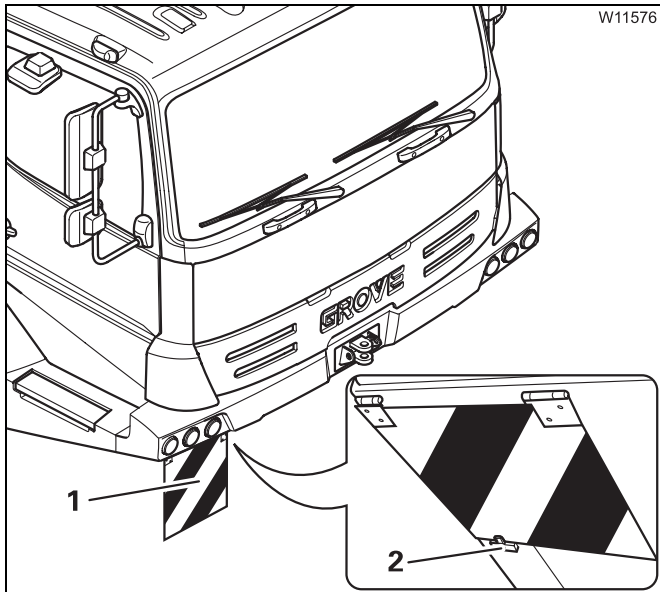



The warning plates (1) must be folded down to indicate the vehicle width during on-road driving.

For off-road driving, the warning plates can be folded up and fastened with the spring latch (2).

Displaying the vehicle height

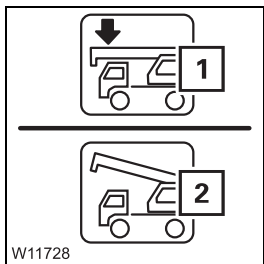
The vehicle height given at on-road driving level is only maintained when the main boom is resting in the boom rest, see p. 8 - 2.



- Open the main menu .

When the display (1) is present, the position of the main boom in the boom rest is monitored.

- Check that the symbol (1) is shown.
- When the symbol (2) is shown, derrick the main boom out until the symbol (1) appears.



Risk of accidents from exceeding the permissible overall height

Check that the symbol  is shown.

Otherwise the given overall height will also be exceeded at on-road level.

Supply pressure

The brake system and some consumers (e.g. differential locks, driver's seat etc.) require sufficient supply pressure in order function properly.

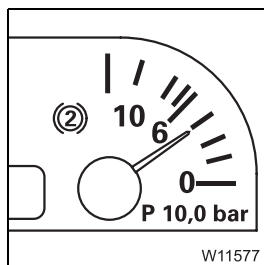

- Check that the supply pressure is approx. 8 bar (116 psi).

If the supply pressure is too low, for example after repairs, you can build it up as follows.

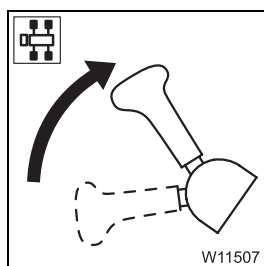

Building up supply pressure

- Check that the parking brake is applied.



Risk of accidents due to the truck crane moving unintentionally

Make sure that the lever is pointing to the rear before building up the supply pressure.

In this way you prevent the parking brake from releasing as soon as sufficient pressure is available and the truck crane starting to move uncontrollably.

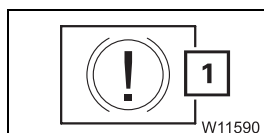

- Allow the motor to run. The supply pressure is being built up. You can speed up this procedure by pressing the accelerator.

With a supply pressure of approx. 5.5 bar (80 psi), the light (1) goes out.

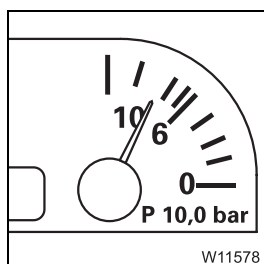

- Refill the supply pressure until
 - approx. 8 bar (116 psi) are reached **and**
 - a valve audibly releases pressure.

Now there is sufficient supply pressure.



You can also show the pressure on the *On-board computer* display;

➡ p. 5 - 23.



Parking brake

Check the function of the parking brake.

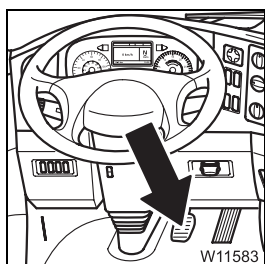

- Activate the service brake.



Risk of accidents due to the truck crane moving unintentionally

Always activate the service brake before releasing the parking brake. In this way you prevent the truck crane from starting to roll in an uncontrolled manner when the parking brake is released.

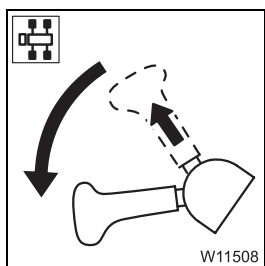

- Release the parking brake.

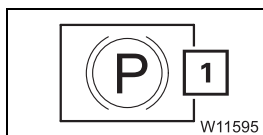

The parking brake is released and the light (1) goes out when the supply pressure is sufficient.

41005067

5.1.3

Adjusting the seats and steering column

Driver's seat

The seat height and lumbar support are adjusted pneumatically. You can only carry out these adjustments when

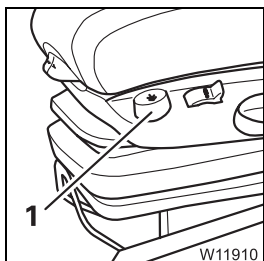

- The switch (1) is switched off on the driver's seat (not pressed in)
- Sufficient air pressure is available in the secondary consumer circuit.
You may have to build up the supply pressure; ►► p. 5 - 9.

- Sit on the driver's seat; the seat will rise to the last position set.

You can make adjustments to suit your body size and shape.

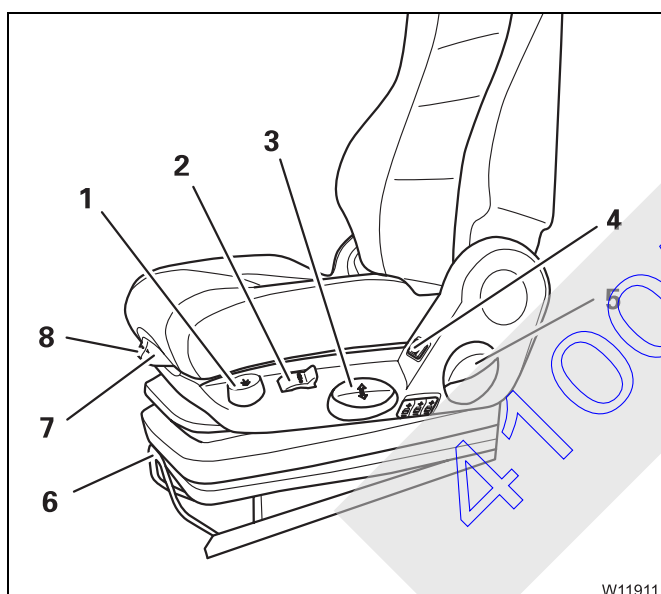

Settings for body size

- 1 Suspension on / off
Lower to lowest position
- 2 Spring hardness
- 3 Seat – height
- 4 Seat heating on / off¹⁾
- 5 Angle of the back rest
- 6 Length adjustment of the seat
- 7 Seat cushion angle
- 8 Length adjustment of the seat cushion

¹⁾ Additional equipment



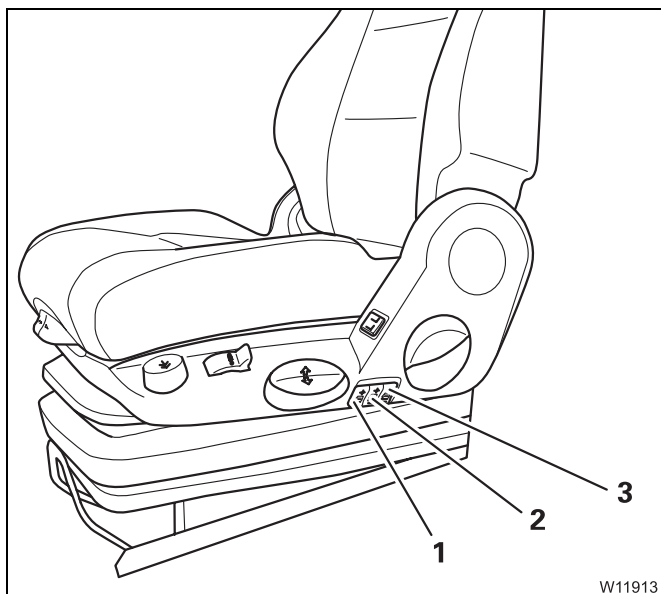

Settings for body shape

- 1 Lumbar area support – bottom
- 2 Lumbar area support – top
- 3 Lateral support

The settings are made pneumatically. The following applies to all buttons:

Empty air cushion: press –

Fill air cushion: press +

Passenger's seat The passenger's seat is adjusted mechanically.

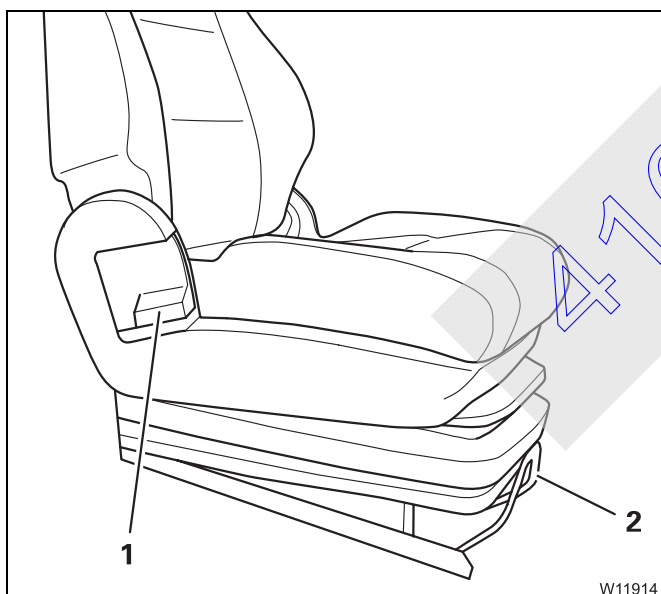

- 1 Angle of the back rest
- 2 Length adjustment of the seat

Adjusting the steering column

The steering column is unlocked pneumatically.



Risk of accidents if the steering column is unlocked

Always stop the truck crane before you unlock the steering column. You can no longer steer safely after unlocking the steering column.



The steering column is only unlocked when sufficient supply pressure has been built up;  *Building up supply pressure*, p. 5 - 9.

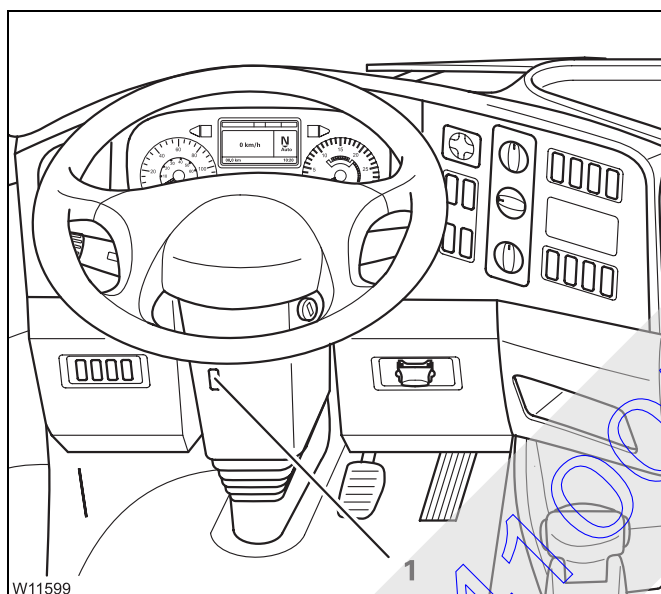

- Press the button (1) down once. The steering column is unlocked for approx. 6 seconds.
- Bring the steering column into the desired position.
- Press the button (1) up once.
Or wait until the steering column is locked automatically (after about 6 seconds).

5.1.4

Switching the suspension on / off

The suspension is switched off whenever the ignition is switched off.
The suspension must be switched on for on-road driving.

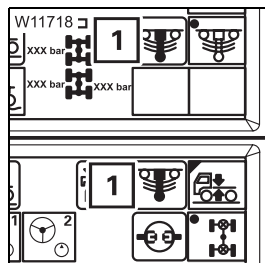

The current switching state of the suspension is shown in the displays (1) in the main menu and in the *Suspension* submenu.

Symbol green: the suspension is switched on

Symbol red: the suspension is switched off

To switch the suspension on and off, you must open the *Level adjustment system* submenu.

Opening the submenu

You can only open the submenu when the truck crane is stationary, or when the current speed is below approx. 5 km/h (3 mph).

- If necessary, open the main menu  and press the button (1) once.

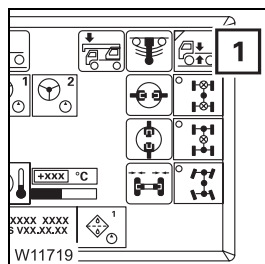

The *Level adjustment system* submenu opens.

The dot (1) indicates the selected switching state:

Dot is green: switch on suspension has been selected

Dot is black: switch off suspension has been selected

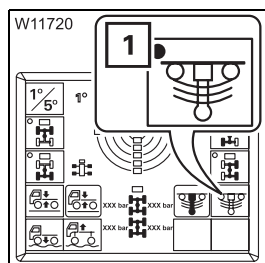

Switching on the suspension

The suspension cylinders are enabled if the suspension is switched on. This state must be established for on-road driving.



Danger of overturning when switching on the suspension

Only switch on the suspension when the truck crane has been rigged for on-road driving and the main boom has been set down. Were the rigged truck crane to be on wheels, the suspension struts would be suddenly pushed together when the crane was switched on, causing them to be damaged and possibly causing the truck crane to tip over.

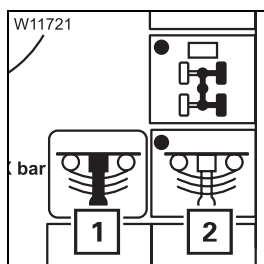

- Press the button (2) once – dot **green**.

When the suspension is switched on, the symbol (1) is **green**.

When the symbol (1) stays **red**, the supply pressure may be too low. In this case the suspension would only be switched on if sufficient supply pressure is built up; ➡ *Building up supply pressure*, p. 5 - 9.

To switch off the suspension

The suspension cylinders are locked if the suspension is switched off. This state is only intended for crane operation.



Risk of damage to the axle lines

Always switch on the suspension for on-road driving. The axle lines may become damaged and the steering behaviour may change if the suspension is switched off.

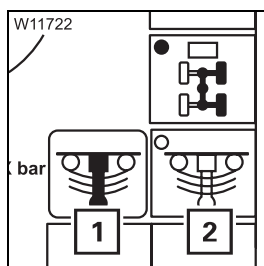

- Press the button (2) once – dot **black**.

When the suspension is switched off, the symbol (1) is **red**.

5.1.5 Adjusting the tachograph

In the tachographs, the diagram sheets (24-hour discs) can be inserted for two drivers simultaneously.

You are obliged as a crane operator to set the respective activity on the tachograph.



This section only describes the basic operation of the tachograph (inserting diagram sheets, setting time groups, operating errors).

Before operation, also note the information in the tachograph manufacturer's separate operating instructions.

There you will find detailed information (marking the diagram sheets, malfunctions, etc.).



Risk of damage to the tachograph drawer

Open the tachograph drawer only to insert or remove diagram sheets and do not use the opened drawer as a shelf or surface (e.g. to mark the diagram sheets). By doing this, you can prevent contamination and damage.

Prerequisites

To set the tachograph, the following requirements must be met:

- The ignition is switched on
- The truck crane is stationary
- No error message is displayed

In the event of malfunctions

check that a malfunction has occurred.

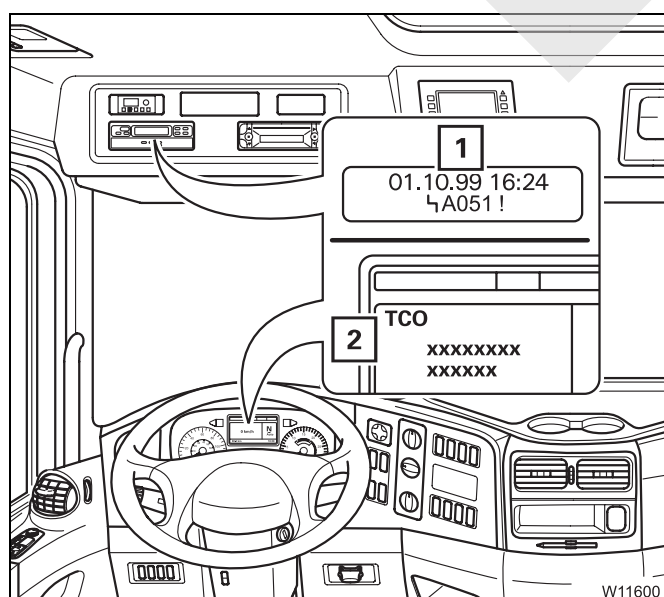

If a malfunction has occurred,

- The *On-board computer* display shows an error message (2)
- The *Tachograph* display (1) shows an error message; *Separate operating instructions* of the tachograph manufacturer.

Adjusting the tachograph

To adjust the tachograph, you must first open the drawer and check the time setting. You can then insert the diagram sheets and set the time groups.

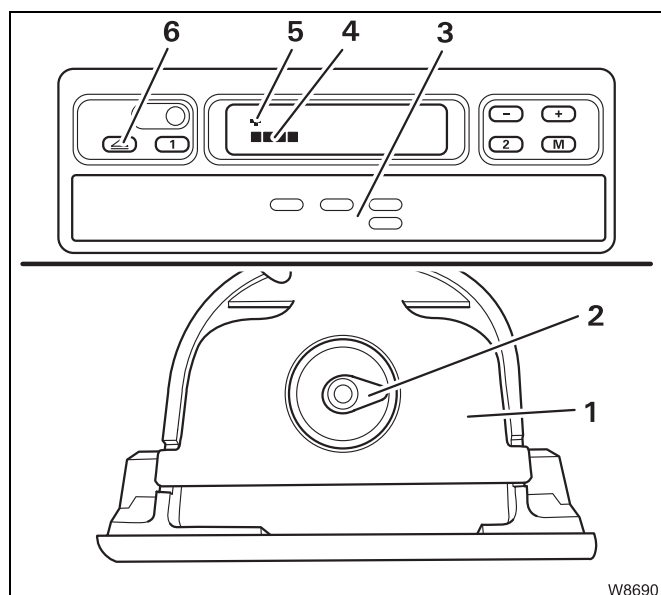

Opening the drawer

- Press the button (6) once.

First the symbol (5) and the running bar (4) appear, then the drawer (3) opens.

- Pull out the drawer (3) as far as possible.

The diagram sheet mounting (2) and an isolating plate (1) are in the drawer.

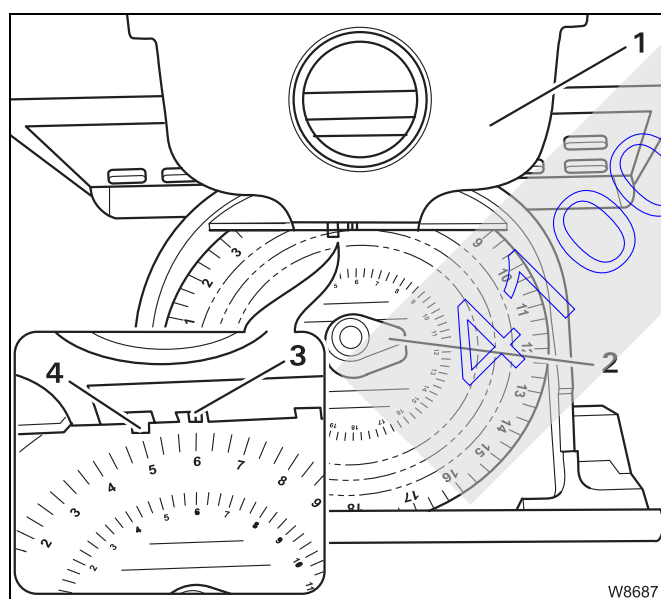

Checking the time setting

- First check the time setting for the diagram sheet mounting (2); fold the isolating plate (1) upwards to do this.
- Insert a diagram sheet. Make sure that the diagram sheet is under the spring (4).
- Check whether the diagram sheet's time scale on the marking (3) is showing the current time.

You can correct the time in the following way:

- Take all the diagram sheets out of the diagram sheet mounting.
- Close the drawer.
The time setting is corrected automatically.
- Open the drawer and insert the required diagram sheets.



Inserting diagram sheets



Only insert diagram sheets which are properly marked.
The diagram sheets are always inserted with the front facing upwards.



Risk of malfunctions in the electronics

If a diagram sheet has been damaged by being marked several times, this might cause malfunctions in the electronics. Therefore, always insert the plastic sheet diagram supplied should you not need to use the tachograph.

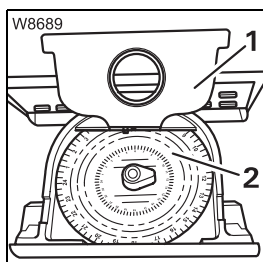

With **2-driver operation** a diagram sheet (2) for driver 2 must be placed below the isolating plate (1):

- After checking the time, leave the diagram sheet (2) where it is.
- After checking the time, insert the diagram sheet (2).

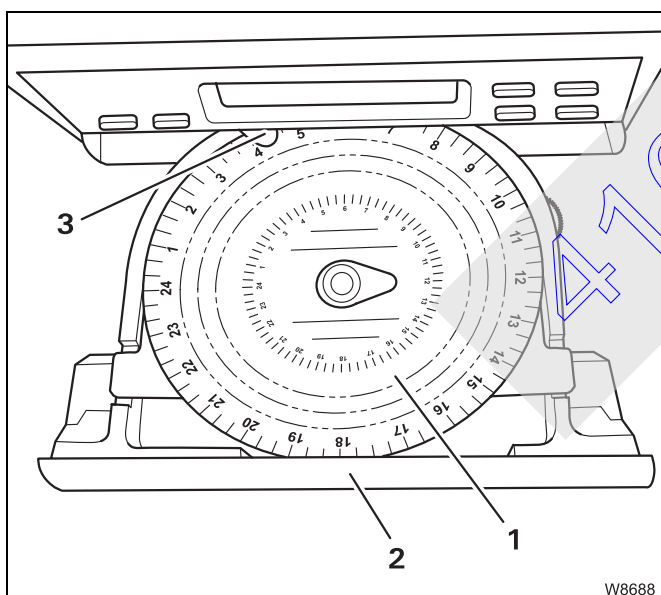

- Fold the isolating plate downwards.
- Put the diagram sheet (1) for driver 1 on the isolating plate.
- Take care that the diagram sheet is under the bracket (3).
- Push the drawer (2) back in until it engages.

For **single-driver operation** the diagram sheet mounting under the isolating plate is empty and only the diagram sheet (1) for driver 1 is inserted.

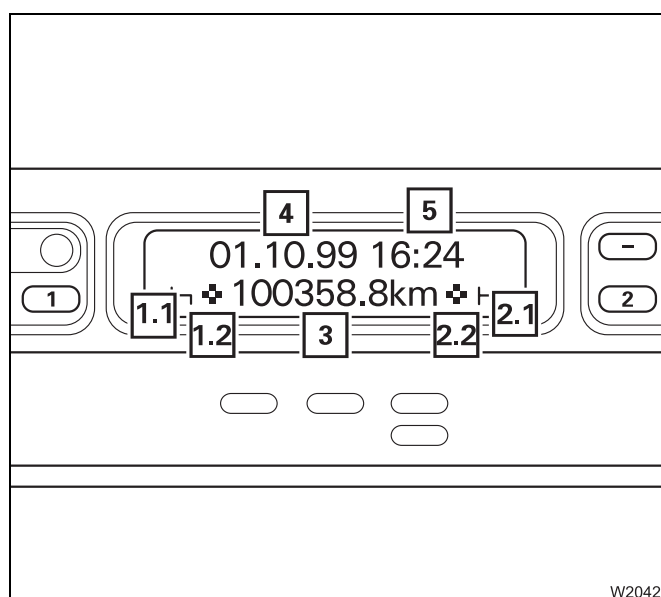

Display

If no malfunction is present, the *Tachograph* display now shows the basic display:

- Date (4) and time (5)
- Driver 1 time group (1.1)
- Driver 1 diagram sheet inserted (1.2)
- Total kilometres of the truck crane (3)
- Driver 2 time group (2.1)
- Driver 2 diagram sheet inserted (2.2)

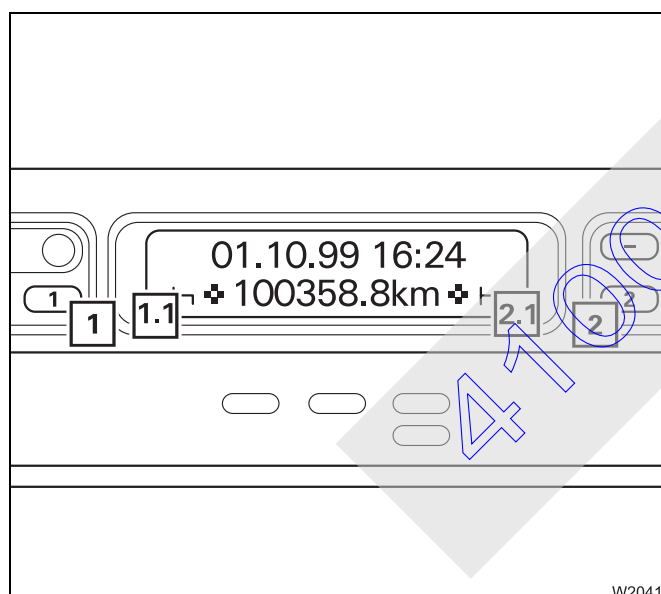

Setting time groups

Set the time group for driver 1 using the button (1).
The set time group is shown with the symbol (1.1).

Set the time group for driver 2 using the button (2).
The set time group is shown with the symbol (2.1).



The different time groups are shown with the following symbols:

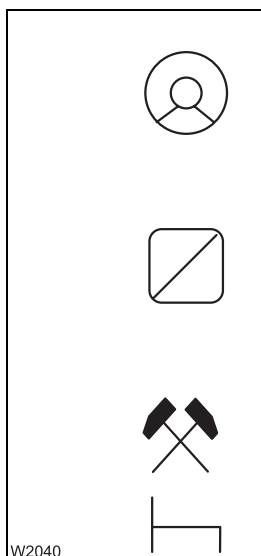

Driving times: As soon as the vehicle starts to move, the tachograph automatically switches to the symbol for driver 1 driving time. If there are two diagram sheets inserted, the tachograph automatically switches to stand-by time for two-drivers operation.

Working hours: For all other work, the same activities apply as do for stand-by time. When setting the working hours and stand-by time, observe the applicable local regulations for the country in which you are working.

Stand-by time: Periods of presence at the truck crane, e.g. crane operation, maintenance work, passenger time etc.

Breaks and periods of rest: These times are prescribed by law and must be observed.



If the drivers swap during **two-driver operation**, the diagram sheets in the trip recorder also have to be changed. The driving time is always recorded on the diagram sheet which is on the isolating plate (driver 1).



The symbol for resting time has to be set for driver 2 in **single-driver operation**. Otherwise an error message will appear.

Additional displays

You can also show the current steering and idle times on the *On-board computer display*;  *Social data / tachograph*, p. 5 - 23.

5.1.6

Displaying the operating hours

You can view the operating hours for all power units in the *Operating Hours* submenu.

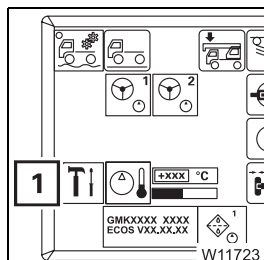

- If necessary, open the main menu  and press the button (1) once.

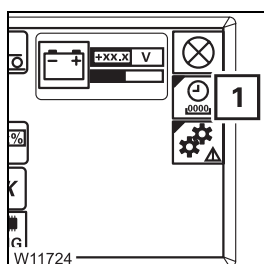

The *Settings* submenu opens.

- Press the button (1) once.

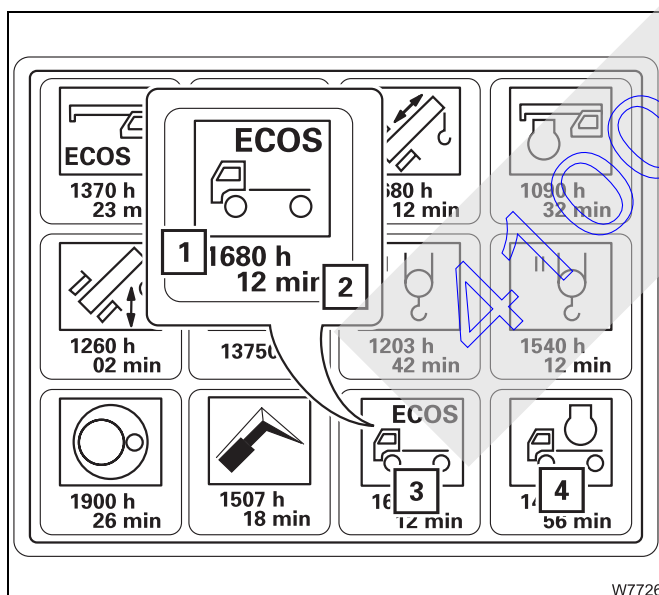

The *Operating hours* submenu opens.

When driving, the ECOS operating hours (3) for the carrier and the engine (4) for driving are recorded:

- The value (1) indicates the hours, e.g. 1680 hours
- The value (2) indicates the minutes, e.g. 12 minutes

The other displays relate to crane operation;  *Displaying the operating hours*, p. 12 - 101.

5.1.7

Settings / displays with the on-board computer

You can make settings, and display e.g. the time, alarm clock and information such as operating hours.

Operation

For operation, you must open the main menus and submenus.

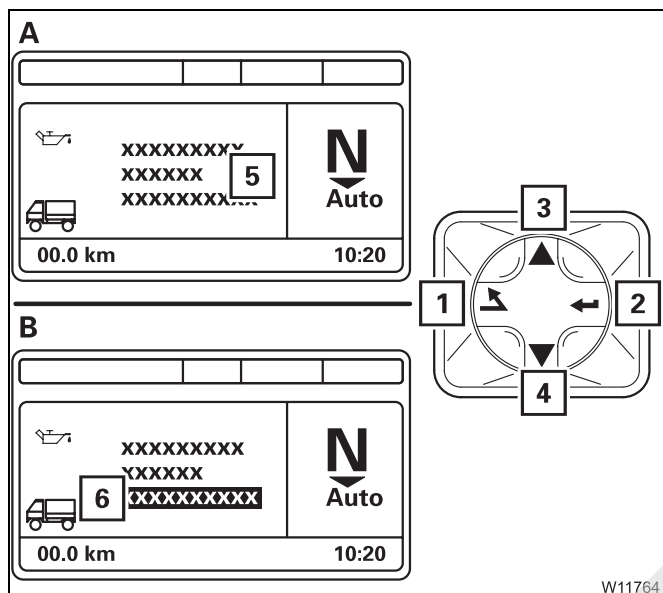

- **(A)** – Press **(1)** or **(2)** until the list **(5)** of the main menus is shown. It contains
 - Inspection information
 - Error information
 - Alarm clock
 - Language
 - Settings
 - Diagnostics
- **(B)** – Use **(3)** or **(4)** to select the required main menu, e.g. Alarm clock **(6)**.
- Press **(2)** once.

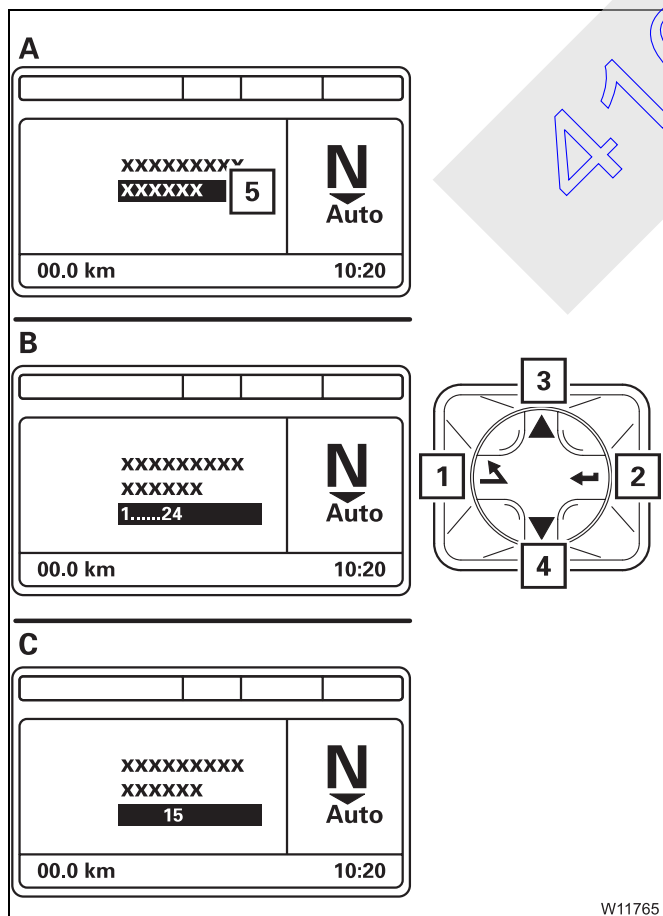

- **(A)** – The main menu opens. The list **(5)** of the corresponding submenu is shown, e.g.
 - Alarm mode
 - Alarm time
- Use **(3)** or **(4)** to select the required submenu, e.g. Alarm time.
- Press **(2)** once.
- **(B)** – Use **(2)** to select the submenu
 - Setting hours 1 24 or
 - Setting minutes 1 60.
- **(C)** – Use **(3)** or **(4)** to select the required setting, e.g. 3pm.
- Save with **(2)** – display **B**.

You can quit the menus with **(1)**.

Overview

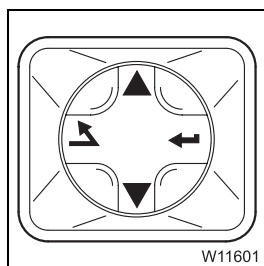

The table shows all main menus and the corresponding submenus.

- Select the required submenu and follow the cross-references for setting and displaying.

Main menu	Submenu	
Inspection information	- Social data	▶ p. 5 - 23
	- Supply pressure	▶ p. 5 - 23
	- Oil level	▶ p. 5 - 24
	- Operating hours	▶ p. 5 - 24
Error information	None	▶ p. 5 - 24
Alarm clock	- Alarm mode	▶ p. 5 - 25
	- Alarm time	▶ p. 5 - 24
Language	None	▶ p. 5 - 25
Settings	- Time	▶ p. 5 - 25
	- Consumables ¹⁾	
	- Temperature unit	▶ p. 5 - 25
Diagnostics	- Control equipment list	▶ p. 5 - 26
	- Delete all events	▶ p. 5 - 27
	- Binary data	▶ p. 5 - 27

1) ||||▶ Maintenance manual

Inspection information

- Open the required submenu; ||||▶ p. 5 - 23.

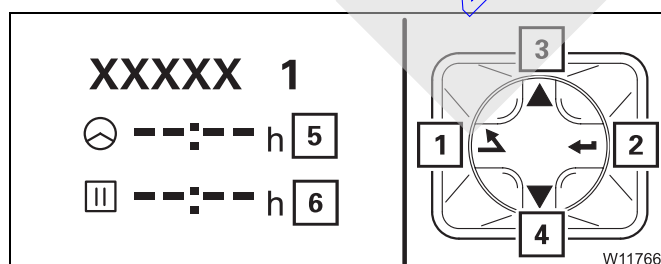

Social data / tachograph

- Select with (3), (4):
Driver 1 or driver 2.
5 Driving time
6 Resting time

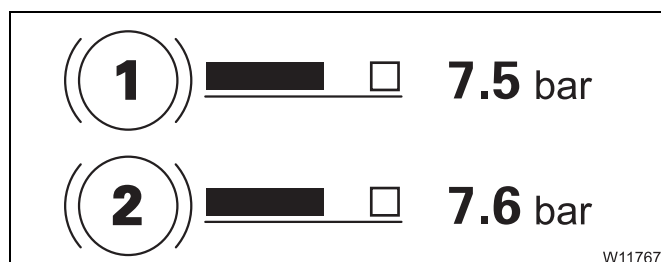

Supply pressure

Display of the current supply pressure

- 1 For brake circuit 1
- 2 For brake circuit 2



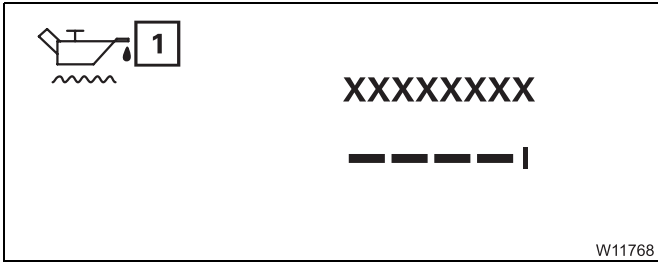

Oil level

No function

W11768

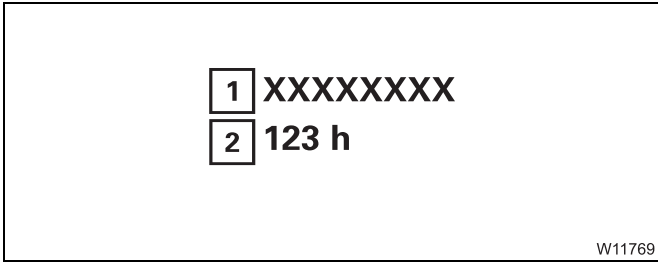

Operating hours

- 1 Text: Operating hours
- 2 Operating hours of the engine, e.g. 123 hours

W11769

Error information • Open the required submenu; p. 5 - 23.

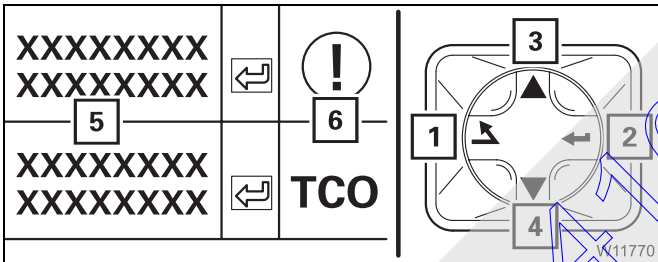

Current message

- Display of the symbol / device (6) and text (5).
- Show an additional text with (2).
- Show additional messages with (3), (4).
- Show error codes; *Diagnostics*, p. 5 - 26.

W11770

Alarm clock • Open the required submenu; p. 5 - 23.

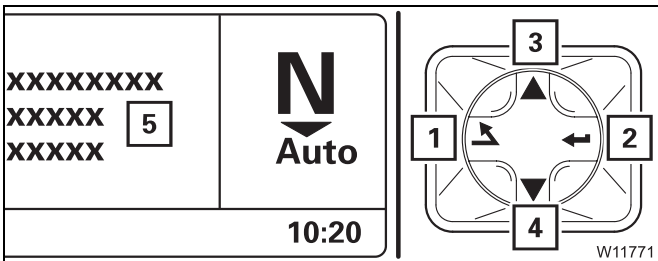

Setting the alarm time

- Text (5): Set the hours
- Use (3), (4) to set, and (2) to store.
- Text (5): Set the minutes
- Use (3), (4) to set, and (2) to store.

W11771

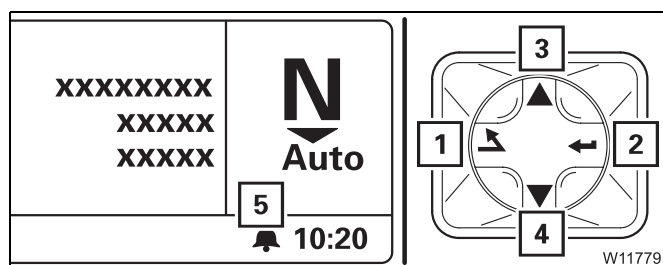

Setting the alarm mode

- Select with (3), (4):
 - Radio / buzzer / off.
- Store with (2), symbol (5) = alarm clock on.

Switch off the alarm signal with (1), (2), (3) or (4)

For a radio alarm, a suitable radio is required.

Language

- Open the required submenu; p. 5 - 23.

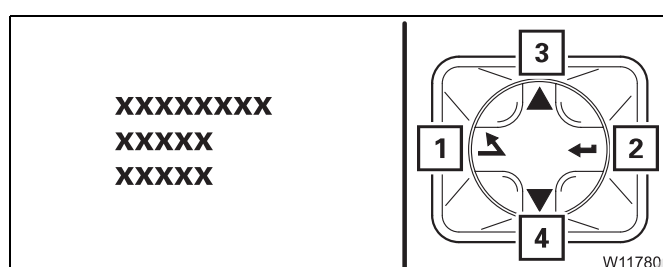

- Select the language with (3), (4).
- Store with (2) – all texts on the *Driving* display are shown in the selected language.

Settings

- Open the required submenu; p. 5 - 23.

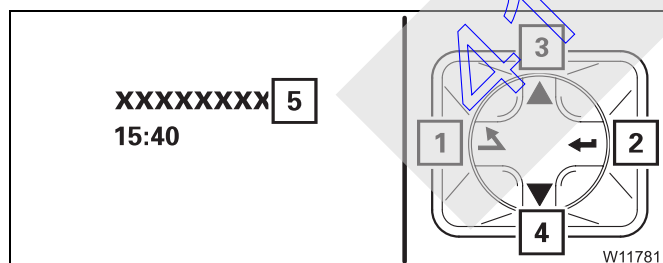

Setting the time

Text (5): Set the hours

- Use (3), (4) to set, and (2) to store.

Text (5): Set the minutes

- Use (3), (4) to set, and (2) to store.

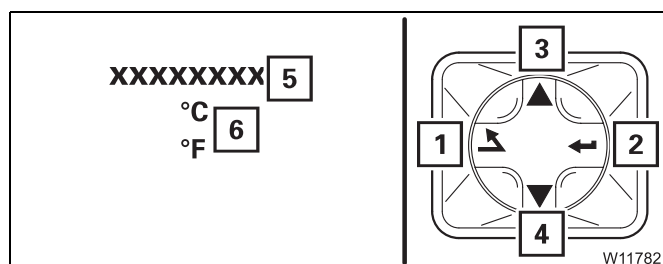

Setting the temperature unit

Text (5): Temperature unit

- Select with (3), (4):
 - Degrees (6) – Celsius / Fahrenheit.
- Store with (2) – the unit applies to all temperature displays on the *Driving* display.



Diagnostics

- Open the required submenu;  p. 5 - 23.

Control equipment list

This only includes a description of how to read error codes. Error codes are only given with messages about control devices. There is

- | | |
|--|-------------------------------|
| ABS: ABS system | GC: Gearbox control |
| FLA: Flame start system | TCO: Tachograph |
| DC: Drive control | MS: Maintenance system |
| ER: Engine regulation | AHE: Auxiliary heater |
| INS: Instrument display (<i>Driving</i> display, lamps etc.) | |



Always read the error code before contacting **CraneCARE**.

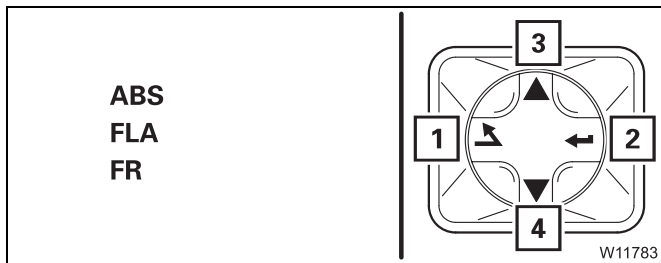

Reading out error codes

- Select the affected control device with (3), (4).
- Show with (2).

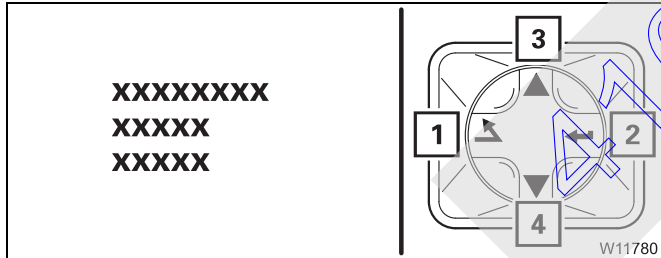

- Select with (3), (4): **Events**.
- Show with (2).

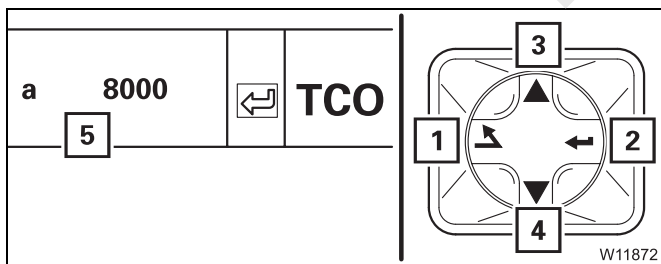

Display (5) error code, e.g. **8000** for **TCO**.

- Show additional errors with (3), (4), if present.
- Go back with (1).

Additional displays are only intended for service work.

The following submenus are only intended for service work.

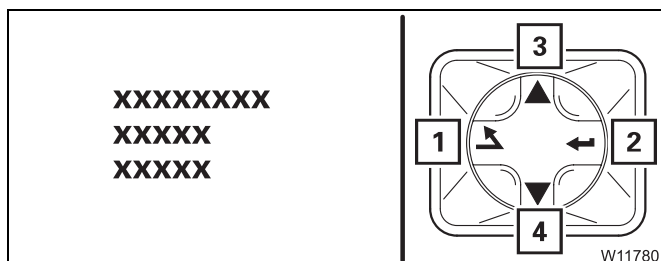

Delete all events

- Select with (3), (4):
Yes / no.
- Store with (2) – when “Yes” selected, all messages on the *Driving* display are deleted.

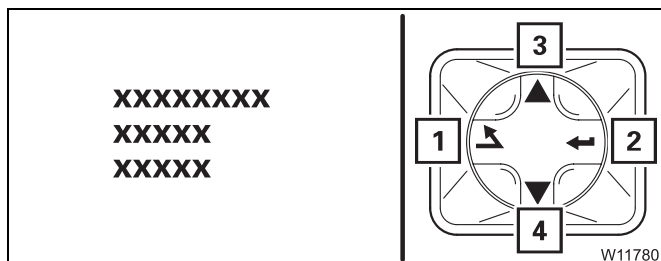

Binary values

- Select with (3), (4), display with (2):

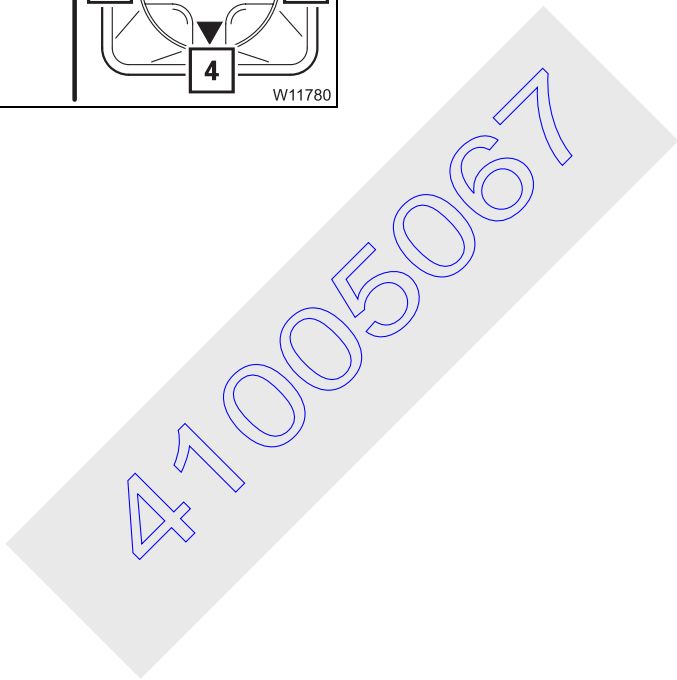

Blank page

41005067

5.2

Operating the transmission

The GMK 4100 truck crane is equipped with a transmission with automatic gear change. The transmission automatically controls the clutch operating mechanism and gear changing. Despite this, gears can be changed manually at any time.

5.2.1

Switching on

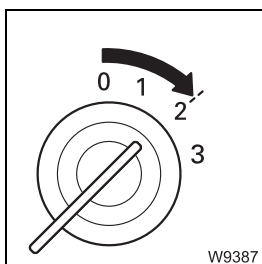

- Turn on the ignition.

The electronic gear system is switched on, and a warning buzzer sounds for several seconds.

If the transmission control detects an error, an error message appears;
 p. 7 - 36.



The *Transmission* display shows the current state of the transmission:

– If the parking brake was applied the last time the ignition was switched off, the transmission will be in neutral position.



– If the parking brake was released, the transmission is set to the gear engaged last, for example the fourth gear.



- If the symbol (1) is still displayed, you must build up the supply pressure;
 p. 5 - 9.



Transmission malfunctions due to insufficient supply pressure

The transmission can only completely shift and do a safe change of gears if sufficient supply pressure is available in the compressed air system.

The transmission is not in neutral position, switch to neutral position;
 p. 5 - 30.

5.2.2

Switching the transmission to neutral position

You can only shift to neutral position if the *Transmission* gearshift lever and the two-stop rocker are in the middle position (home position).



Risk of accidents due to truck crane starting to move

Always apply the parking brake or the service brake before you switch to the neutral position. This prevents the truck crane from starting to move unintentionally.

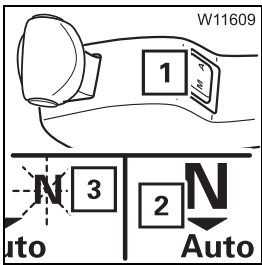

- Press the button (1) once.

First the entry (3) flashes, and when the neutral gear is switched on, the entry (2) is shown.

Switch the transmission to neutral position to start the engine. The engine may only be started in this position.

5.2.3

Changing the operating mode

Change-over to automatic mode

This operating mode is intended for on-road driving.

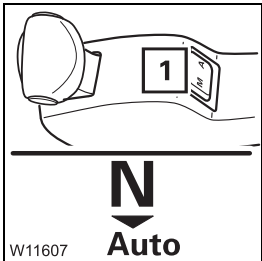

- Press the switch (1) down at **A**.
The **Auto** entry is shown.

The gears are shifted automatically, depending on the load. You can shift gears manually at any point in time – the automatic mode is active immediately after and will shift gears as required.

Change-over to manual mode

This operating mode is intended for driving on land with rapidly changing load conditions and for driving in emergency operation.

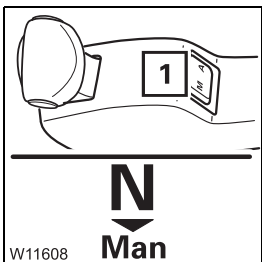

- Press the switch (1) down at **M**.
The **Man** entry is shown.

Gears can only be shifted with the switch lever or with the two-stop rocker. Gears are not shifted automatically.



The various functions in the two operating modes are described in detail in the following sections.

5.2.4

Display of the selected gears

Example:



In initial position, the fifth gear is engaged as half gear. The gear **5** selected is shown with an arrow pointing downwards.



If you shift down half a gear, the fourth gear is engaged as a full gear. The gear **4** selected is shown with an arrow pointing upwards.



If you shift down half a gear again, the fourth gear is engaged as a half gear. The gear **4** selected is shown with an arrow pointing downwards.

If you shift down from the initial position by a full gear, the fourth gear will be selected as a half gear directly and displayed.

5.2.5

Selecting the direction of travel and starting gear

Selecting the driving direction



The following conditions must be met:

- The parking brake is applied
- The vehicle engine is switched on and
- The accelerator is not operated

Risk of accidents due to the truck crane moving unintentionally

When starting the truck crane, always use the service brake to stop the crane from moving until the starting gear has been engaged.

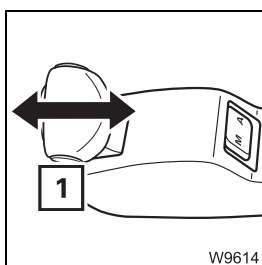

For forward travel

- Press the button **(1)** and additionally push the switch lever forwards once.

For reverse travel

- Press the button **(1)** and additionally push the switch lever backwards once. Depending on the equipment, an acoustic signal can be heard.



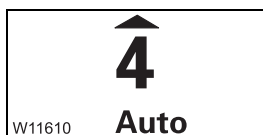

– In *Automatic* operating mode an appropriate starting gear is selected between the first and fourth gear or a reverse gear.



– The second gear is selected as a full gear in *Manual* operating mode or a reverse gear.

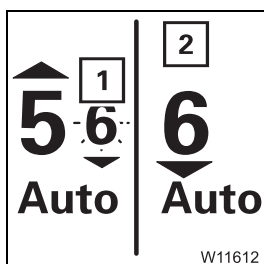

The following applies to all gear shifts:

A preselected gear, e.g. gear 6, always flashes first on the display (1). When the gear is selected, it is shown on the display (2) and the display (1) disappears.

Selecting the starting gear

You can now change the gear step-by-step by a full gear or half a gear.

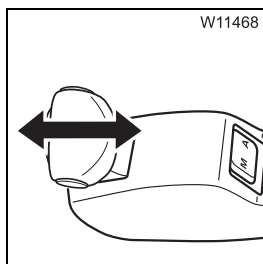

Changing by a full gear

- Press the gearshift lever forwards / backwards once.
The starting gear is upshifted / downshifted by a full gear.

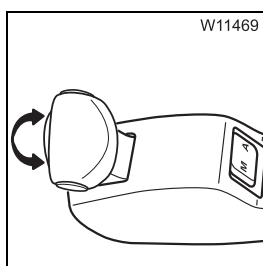

Changing by half a gear

- Push the two-stop rocker upwards / downwards once.
The starting gear is upshifted / downshifted by a half gear.



The changed starting gear is displayed, e.g. the fourth gear as half a gear.

5.2.6

Starting



Risk posed by unexpected rolling

Also apply the parking brake before starting on sloping ground. The gear will only be engaged after you step on the accelerator. This can lead to the truck crane starting to move (also backwards) while you are moving your foot from the brake pedal to the accelerator.

To start moving, you have to:

- Apply the parking brake
- Step on the accelerator (starts clutching)
- Release the parking brake after the gear has engaged (motor sound changes).

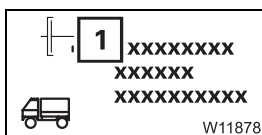

Warning when starting

When the load during starting is so large that it would cause the clutch to overheat, a warning buzzer sounds. The message (1) also appears; p. 5 - 56.

- In this case, remove your foot from the accelerator immediately and actuate the service brake.



Risk of clutch damage

Always release the accelerator when the lamp (1) lights up. The clutch will become overheated and damaged if you do not stop the starting procedure.



- Switch to neutral position and leave the vehicle engine running until the coupling has cooled down and the message (1) is no longer shown on the display.
- Select a lower starting gear.
- Start to move again.



When driving extremely slowly, the transmission switches automatically to manoeuvring mode and the truck crane responds more sensitively to the accelerator.

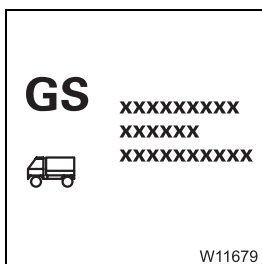

When a transmission malfunction is detected, the *On-board computer display* shows corresponding entries; *Messages on the on-board computer display*, p. 5 - 50.

5.2.7

Driving and changing gears

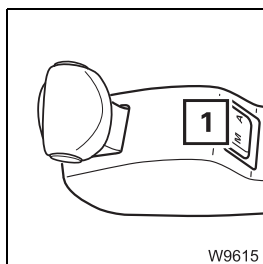

Depending on the position of the switch (1), the transmission is either in *Automatic* operating mode (A) or in *Manual* operating mode (M).

In automatic operating mode

In this operating mode, the transmission changes to the gear suitable for the current load, engine speed and position of the accelerator.

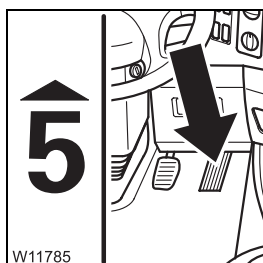

Automatic upshifting

You can influence upshifting by using the accelerator.

- Pressing the accelerator slightly: upshifting at low engine speed
- Pressing the accelerator harder: upshifting at high engine speed



The transmission upshifts by no more than half a gear if you operate the accelerator while the engine retarder is switched on.

Automatic downshifting

- When you slow down the truck crane by braking, the transmission shifts down when the appropriate engine speed is reached.
- When you step on the accelerator to the full (kick down), the transmission first shifts to a lower gear. After that, it will shift to a higher gear once a higher engine speed has been reached in order to attain maximum acceleration.

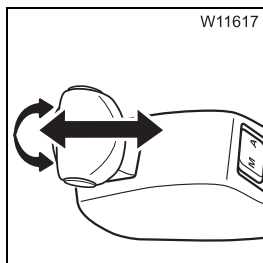

Also, you can **change gears manually** at any time. Proceed in the same manner as with *Manual* operating mode.

Automatic mode immediately switches back to a suitable gear, depending on the current load, speed and position of the accelerator.

In manual operating mode

In this operating mode, the transmission only shifts when you actuate the gearshift lever or the two-stop rocker.

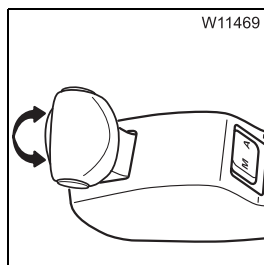

– Shifting by ½ gear

- Upshifting:
 - pull the two-stop rocker upwards once.
- Downshifting:
 - push the two-stop rocker downwards once.

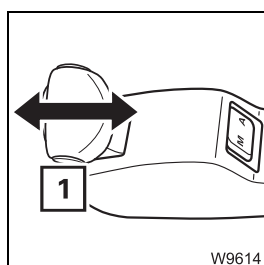

– Shifting by 1 gear

- Upshifting:
 - Press the button (1) and additionally push the switch lever forwards once
- Downshifting
 - press the button (1) and additionally pull the switch lever backwards once.

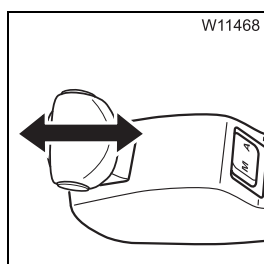

– Gear shifting depending on driving mode

- Upshifting:
 - press the gearshift lever forwards once.
- Downshifting
 - pull the gearshift lever backwards once.

The transmission shifts to a gear suitable for the current driving mode. It upshifts or downshifts by at least ½ gear.



The change of gear is completed once the newly selected gear, for example the fifth gear as half gear, is displayed.

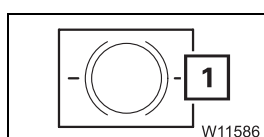

If you initiate a gear change in which the maximum permitted speed would be exceeded, the warning buzzer sounds and the lamp (1) lights up.

- In this case, apply the brakes.
The gear will be shifted as soon as a permissible engine speed has been reached.



5.2.8

Changing the driving direction

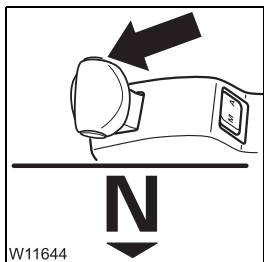

- Stop the truck crane
- Secure the truck crane with the service brake or parking brake.
- Switch to neutral position.

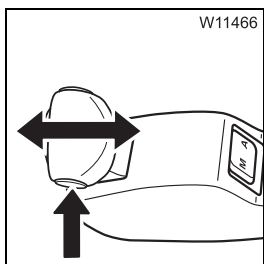

- Select the starting gear for the opposite driving direction;  p. 5 - 31.

Quick change of gear



You can also switch directly between reverse and first gear (without neutral position), for example when rocking free.

- Stop the truck crane and leave the engine running.
- Switch to reverse gear – a requirement for direct gear changing.

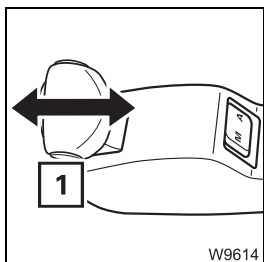

- Press the button (1) and additionally push the switch lever forwards once. The first gear is engaged.
- Press the button (1) and additionally push the switch lever backwards once. The reverse gear **R** is engaged.



Direct gear changeover is released until you switch to neutral gear.

5.2.9

Stopping

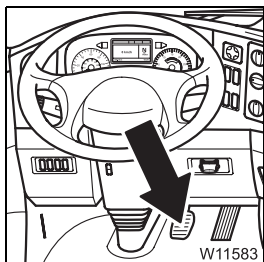

- In order to stop, remove your foot from the accelerator and actuate the service brake.

The transmission disengages shortly before the idling speed is reached. After stopping, the transmission responds in different ways:

– **In automatic operating mode**

As soon as the truck crane is stationary, a suitable starting gear is engaged.

– **In manual operating mode**

The current gear remains engaged. If the fifth to eighth gear is engaged, you need to downshift before starting. The truck crane can only start in one of the first four gears.



The transmission switches to neutral position 90 seconds after stopping in either of the two operating modes.

The entry **N** flashes after 60 seconds. The selected starting gear remains engaged for another 90 seconds if you tap on the accelerator now.

Stopping for a long period of time

In order to stop for a longer time with the engine running, you must:

- Apply the parking brake
- Shift the transmission to neutral position

5.2.10

On the roller type dynamometer

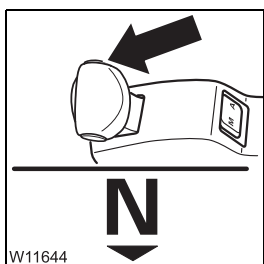

- Always switch to neutral position after driving onto a roller type dynamometer.

Blank page

41005067

5.3

Driving and turning off the truck crane



Risk of accidents due to the fact that the truck crane cannot be steered

Never switch off the ignition or remove the ignition key while the truck crane is moving

In this way you prevent the steering from locking and do not lose control of the moving truck crane.

5.3.1

Inspections while driving

Immediately after you start to move

- Check the service and parking brakes for correct functioning.

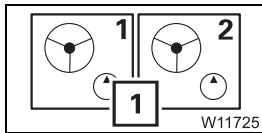

Symbols for steering

- Check the symbols (1) in the main menu.

At speeds of over 10 km/h (6 mph) both symbols (1) must be **grey**. When a symbol is **red**, a malfunction has occurred in the steering.



Risk of accidents if the steering circuits fail

Stop the truck crane immediately if both symbols are red.

The steering is sluggish and the truck crane can no longer be steered safely.



Risk of accidents if one of the steering circuits fails

When a symbol is red, reduce the speed. Stop the truck crane at the next opportunity and try to find the cause.

You may continue to drive **slowly** in order to reach the next garage if one of the steering circuits fails.

▮▮▮▮ ➔ *Steering malfunctions, p. 7 - 27*



Lamps for the ABS system

- Check the lamps (1).

With speeds of above 6 km/h (4 mph), **the lamps (1)** must go out. Then the **Anti-Blocking System (ABS)** is able to function, and the wheels are prevented from being blocked when you brake.

If a lamp does not go out, the corresponding ABS system is faulty, and the wheels will no longer be prevented from blocking. The full braking force remains intact. **Service brake malfunctions**, p. 7 - 26.

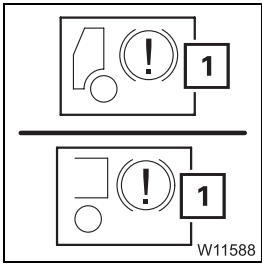

While driving

- Observe all warning messages.

Risk of damage if warning messages are not observed

After a warning message appears (on the *ECOS* display or *On-board computer* display, always observe all information in the section titled Warning submenu in good time, and take the appropriate remedial measures. In this way, you can prevent these malfunctions from causing malfunctions on the truck crane.



- If one of the lamps (2) which has already been checked lights up again, or when a symbol (1) turns red, observe the information in the previous section.

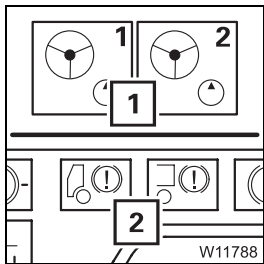

- When the lamp (1) lights up, stop the truck crane immediately and check the message on the *On-board computer* display; **Service brake malfunctions**, p. 5 - 50.

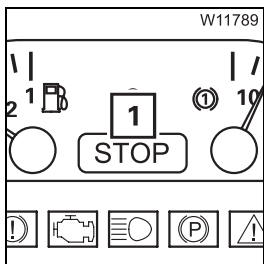

- When the lamp (1) is lit, the *on-board computer* display shows a corresponding message; **Service brake malfunctions**, p. 5 - 50.

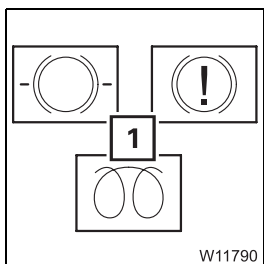

- When the *ECOS* display shows a warning message (1); **Warning submenu**, p. 5 - 48.

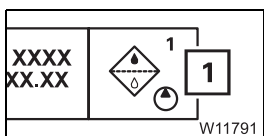

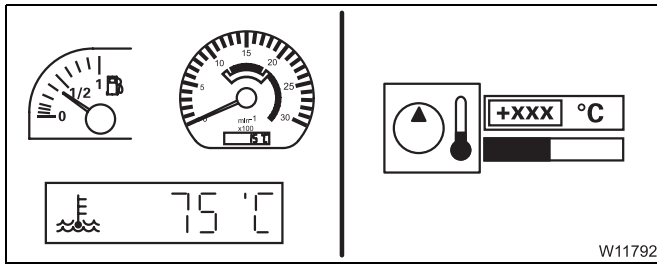

- Also note the control elements for fuel supply, engine speed, coolant temperature and hydraulic oil temperature; p. 4 - 17.

5.3.2 Tempomat

The Tempomat enables you to drive at a constant speed without pressing the accelerator.



Risk of accidents due to carelessness

Be ready to brake at all times when the tempomat is switched on. Only switch the tempomat on if the traffic situation permits a constant speed.

Switching on

You can only switch on the tempomat at speeds of over 15 km/h (9 mph).

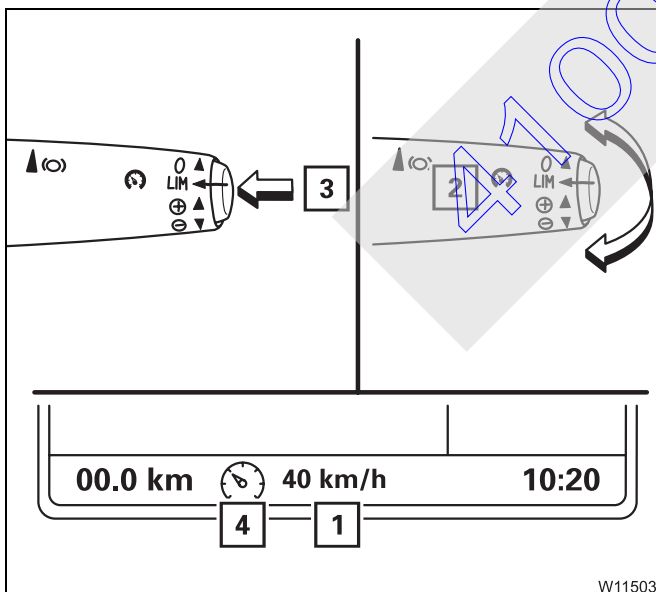

- With the **(3)** button, switch the tempomat on – symbol **(4)** is shown.
- Press the switch **(2)** upwards / downwards once.

The tempomat is switched on. The current speed **(1)** is shown and maintained, e.g. 40 km/h.

You can exceed the speed **(1)** with the accelerator. After the accelerator is released, the tempomat goes back down to the speed **(1)**





On downhill slopes, the speed set may be exceeded since the Tempomat does not brake the truck crane. Switch the Tempomat off on downhill slopes.

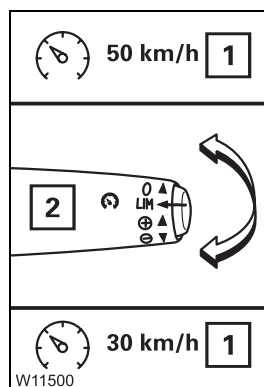

Increasing / reducing the speed

- Press the switch (2) up / down until the required speed (1) has been reached.

or

- Press the switch (2) upwards / downwards once. The speed (1) will increase / reduce by 0.5 km/h (0.3 mph).

The set speed (1) is maintained.

Switching off

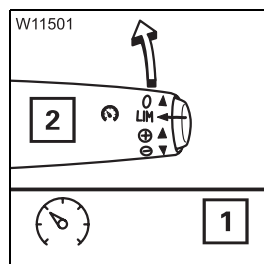

- Push the switch (2) forwards once. The tempomat is switched off, and the display (1) disappears.

The tempomat is also switched off

- When the service brake or additional brake is activated
- When 10 km/h (6 mph) is exceeded
- When the tempomat function is switched on
- When the ignition is switched off
- And when you push the switch forwards once

5.3.3 Temposet

You can use the temposet to limit the maximum speed.

Switching on

You can only switch on the temposet at speeds of over 15 km/h (9 mph).

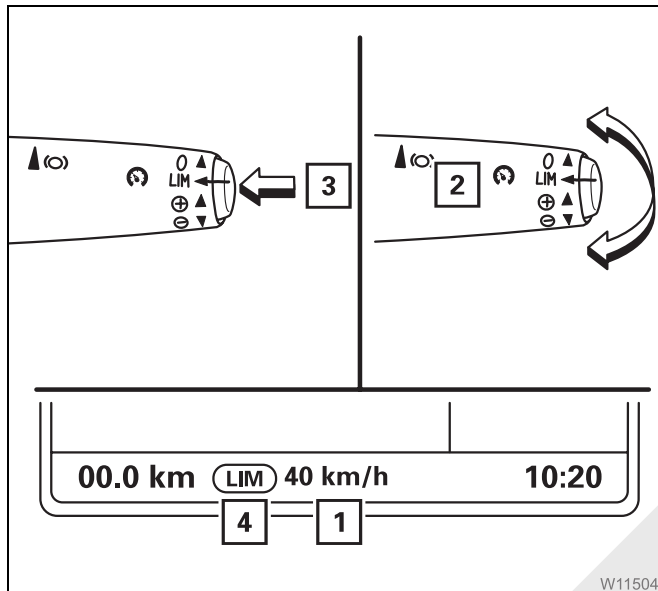

- With the (3) button, switch the temposet on – symbol (4) is shown.
- Press the switch (2) upwards / downwards once.

The temposet is switched on. The current speed (1) is shown and is used as the maximum speed, e.g. 40 km/h.

You can exceed the speed (1) by pressing the accelerator as far down as it will go (kick-down). The temposet only goes back down to the speed (1) when you release the accelerator and press it again.

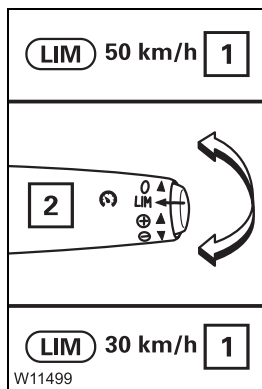

Increasing / reducing the maximum speed

- Press the switch (2) up / down until the required speed (1) is shown.
- or
- Press the switch (2) upwards / downwards once. The speed (1) will increase / reduce by 0.5 km/h (0.3 mph).

Switching off

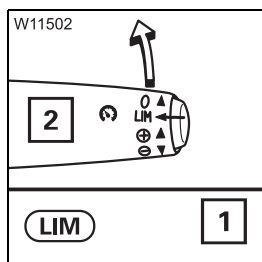

- Push the switch (2) forwards once. The temposet is switched off, and the display (1) disappears.

5.3.4

Driving downhill



Risk of accidents when driving in neutral position

Never switch into neutral position while driving.

In neutral position, the truck crane may accelerate and the engine retarder is ineffective.

Starting

The engine must be running.

To start moving, you have to:

- Select a starting gear
- Release the parking and service brakes
- Operate the accelerator – the clutch is engaged and a gear suitable for the current speed is selected



If the truck crane starts to move forwards in neutral position, you can still select the *forwards* driving direction. A gear which is suited to the speed is engaged and the engine brake power is effective.

Inspections when driving downhill

While driving, the engine speed may not exceed 2300 min⁻¹ (rpm). The speed is not automatically limited.



Risk of damage due to excessive engine speed

Shift to a higher gear or slow the truck crane down when the maximum permissible engine speed has been reached.

This prevents the engine or transmission from being damaged or the air intake inhibitor from being triggered.

If an air intake inhibitor is present, it will be triggered if the maximum permissible engine speed is exceeded and the motor will stop running;

▣ p. 4 - 23.

- Check the current speed on the tachometer while driving.
- Brake the truck crane before the engine speed increases into the red range (1) – over 2300 min⁻¹ (rpm).

When the maximum permissible engine speed is reached, a warning buzzer sounds.

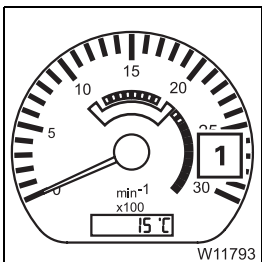

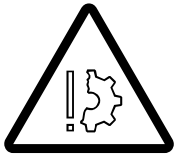

Risk of damage from oscillating movements

Always maintain a speed below 85 km/h (53 mph). Stop the truck crane in good time.

When driving downhill, you can also slow down the truck crane as follows, in addition to using the service brake:

- By shifting down; p. 5 - 45
- With the additional brake; p. 5 - 46
- With the eddy current retarder; p. 5 - 47

Downshifting

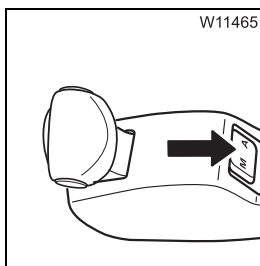

To increase the braking force of the engine, you can select a lower gear.

- Downshift half a gear or a full gear.

If possible, downshift one full gear.

If automatic mode upshifts immediately after, switch to *Manual* operating mode and repeat gear shifting.

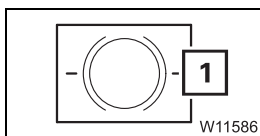

If the maximum permitted speed would be exceeded by downshifting, a warning buzzer sounds and the lamp (1) lights up.

- In this case, apply the brakes. The gear will be shifted as soon as a permissible engine speed has been reached.

If the maximum permitted speed is also reached in the lower gear, you must brake again, or switch on the engine retarder / eddy current retarder.



Additional brakes

Engine retarder

The truck crane has an engine flap brake which it uses as an engine retarder. The engine retarder only becomes effective at an engine speed of 900 min⁻¹ (rpm) and can be used up to a maximum speed of 2300 min⁻¹ (rpm).



Risk of accidents due to unexpected acceleration

Maintain sufficient distance when the engine retarder is switched on. The effectiveness of the engine retarder is interrupted during gear shifting. This may cause the truck crane to accelerate briefly.

Eddy current retarder

The truck crane can also be rigged with an eddy current retarder. The braking force of the eddy current retarder depends on the speed. The higher the speed, the higher the brake power.



For long downhill drives, we recommend that you use level 2. When the eddy current retarder is switched on, you cannot regulate the speed with the accelerator.

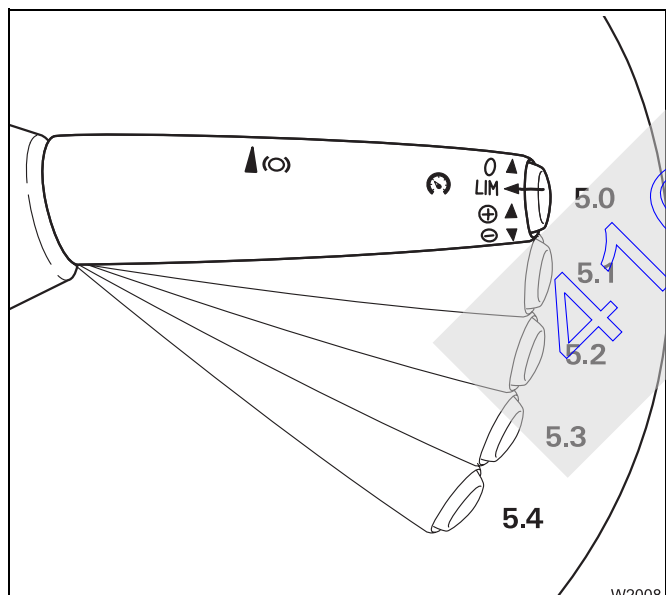

Switching on the additional brakes

- Pull the switch back to the required level (latch into place briefly at each level).

5.1 Only engine retarder

Connection to the retarder power:

- 5.2** 50% power
- 5.3** 75% power
- 5.4** 100% power

Switching off the additional brakes

- Press the switch forwards to level 5.0.

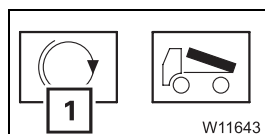

When the additional brake is switched on, the lamp (1) lights up.

5.3.5

Driving uphill

Starting

The engine must be running.

To start moving, you have to:

- Apply the parking brake
- Select a starting gear
- Operate the accelerator (gear is engaged)
- Release the parking brake and press the accelerator as far as it will go (*Load* starting mode is active).

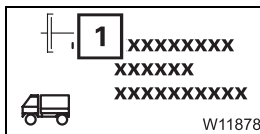

When a warning buzzer sounds when starting and the message (1) appears:

- Remove your foot from the accelerator immediately and actuate the service brake. For the subsequent procedure;  *Warning when starting*, p. 5 - 33.

Driving

The transmission can switch between two gears for certain gradients. In that case, either release the accelerator slightly or downshift by one gear.

41005067

5.3.6 Warning submenu

ECOS differentiates between warning messages and error messages (error messages; [Error submenu](#), p. 5 - 50). A warning message indicates that certain values do not correspond to a set value.

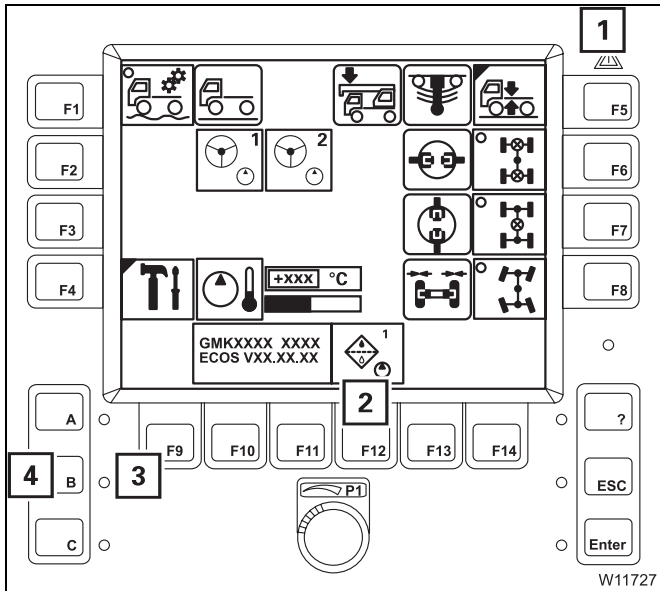

With a warning message:

- The lamps (1) and (3) flash
- The display (2) shows the red symbol for the pending warning message.

For further information

- Press button (4) once – the *Warning* submenu opens.

The warning message has been acknowledged – the lamp (3) lights up (no longer flashes).

Meaning of the symbols

The colours of the symbols indicate whether a warning message is active in the corresponding area:

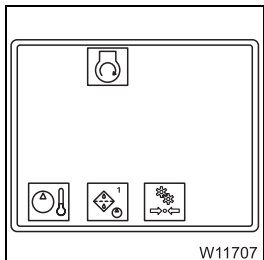

- Symbol **grey** – no warning message.
- Symbol **red** – warning message.

Make the following inspections if a symbol is displayed in **red**.



Risk of damage if warning messages are not observed

Observe the following information in good time and take the appropriate remedial measures if a warning message appears. In this way, you can prevent these malfunctions from causing malfunctions on the truck crane.



Hydraulic oil too hot

The hydraulic oil is hotter than 80 °C (176 °F).
Display of the current temperature; ■■■► p. 4 - 17.
Possible cause and remedy; ■■■► p. 7 - 28.

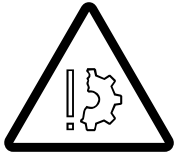

Danger of overheating

There is a fault if the hydraulic oil temperature exceeds 80 °C (176 °F). Stop the truck crane at the next opportunity and try to find the cause.
Stop the truck crane immediately and turn off the vehicle engine if the temperature of the hydraulic oil rises to over 100 °C (212 °F).

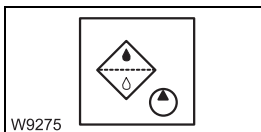

Replacing the hydraulic oil filter

Replace the hydraulic oil filter as quickly as possible; ■■■► *Maintenance manual*

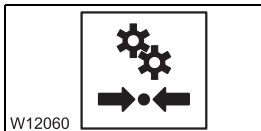

Supply pressure in secondary consumers too low

The supply pressure is below approx. 6.0 bar (87 psi); ■■■► *Building up supply pressure*, p. 5 - 9.

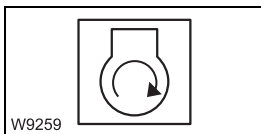

Air intake inhibitor triggered

The air intake inhibitor was triggered because the maximum permissible engine speed was exceeded. It is only possible to start the engine after the air intake inhibitor has been released manually; ■■■► p. 4 - 23.

Exiting the submenu

You can exit the submenu at any time.

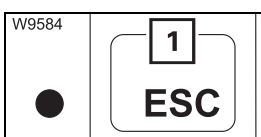

- Press the button (1) once.
The same menu opens which was open before the *Warning* submenu opened.

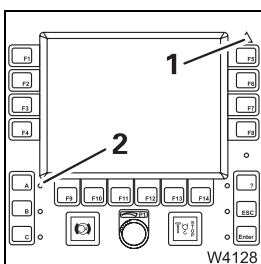

If the same warning messages are still present, the lamps (1) and (2) light up.

If no warning message is present, both lamps will have gone out.

Both lamps start to flash again as soon as a new warning message occurs.

5.3.7 Error submenu

ECOS differentiates between error messages and warning messages (warning messages) \Rightarrow *Warning submenu*, p. 5 - 48).

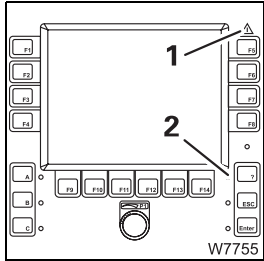

In the event of an error message the lamps (1) and (2) flash.

Further information on the *Error submenu*; \Rightarrow *Malfunctions on the ECOS carrier*, p. 7 - 30.

5.3.8 Messages on the on-board computer display

Messages are shown automatically. There are three types of message.

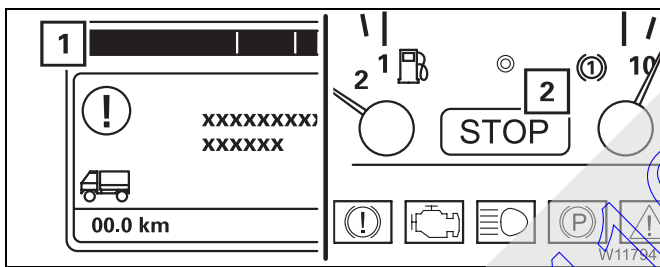

- Warning message

Display (1) red, lamp (2) lights up.

- Stop as quickly as possible, taking account of the traffic situation.

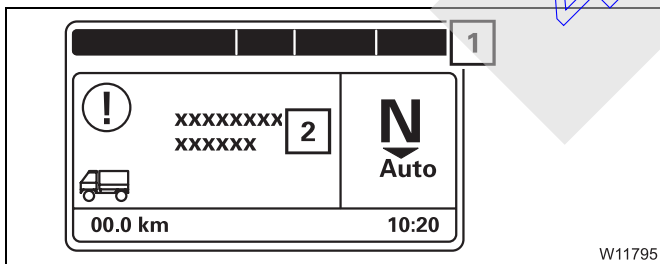

- Error message

Display (1) red

- Information

Display (1) yellow

- Check the cause when you next stop, or stop when the text (2) requests you to do so.

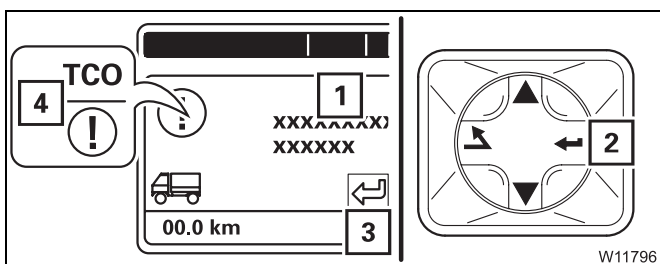

Message elements

Messages consist of texts (1) and symbols / abbreviations (4).

When the symbol (3) is shown, you can display an additional text by pressing (2).

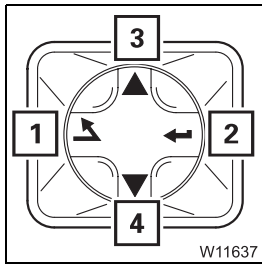

Acknowledging a message

- Press (1) once – the message disappears.

You can retrieve all existing messages in the *Error info* submenu;
▮▮▮▮ p. 5 - 22.

Warnings

This section does not include all messages. The messages shown here can also appear with additional or different texts.

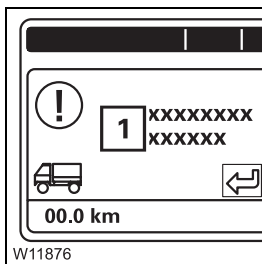

If in doubt, the current text (1) shown in your truck crane always applies. Follow the requests to stop immediately and conduct the measures given in good time.



Risk of damage if messages are not observed

For all messages, always take note of the text shown.

Follow the requests to stop immediately, taking the traffic situation into account. Complete the remedial measures shown, and described here, in good time.

This avoids errors, and slight damage leading to more serious problems.

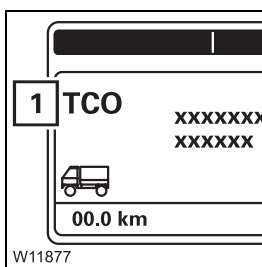

If an abbreviation (1) is shown, you can read off the error codes for the corresponding control device.

Always read off the error codes before contacting **CraneCARE**.

For an overview of the control devices and reading off the error codes;
▮▮▮▮ p. 5 - 26.



Warning messages

This section provides information about different warning messages.

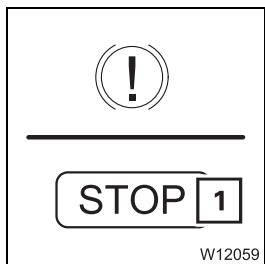

Current text:	Brake supply pressure too low
----------------------	-------------------------------

The lamp (1) lights up.



Risk of accidents if one or both brake circuits fail

Stop the truck crane immediately, taking into account the traffic situation, and identify the cause.

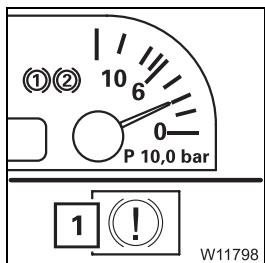

The pressure in one or both brake circuits is below approx. 5.5 bar (80 psi). The lamp (1) lights up.

- Open the *Supply pressure* submenu; *Operation*, p. 5 - 22.
- Check the supply pressure in both brake circuits:

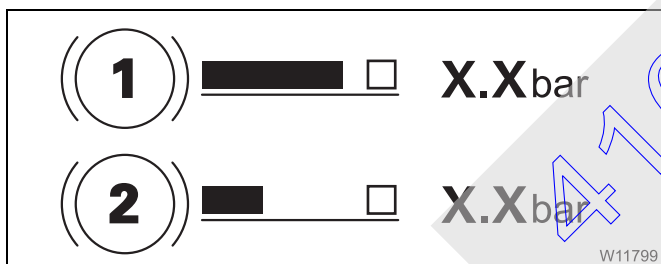

If the supply pressure in only **one** display, e.g. (2) is below approx. 5.5 bar (80 psi) and you cannot rectify the cause, you may still continue driving at a low speed until you reach the next garage.

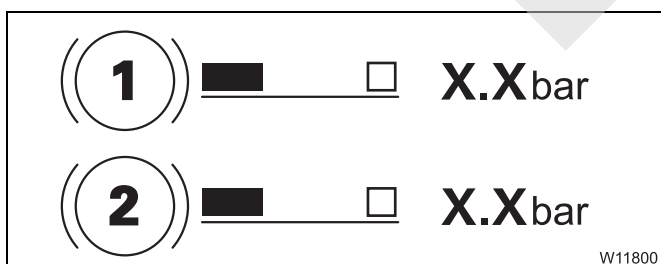

If the supply pressure on **both** displays is below approx. 5.5 bar (80 psi), apply the parking brake. You may only continue driving after the vehicle has been repaired.

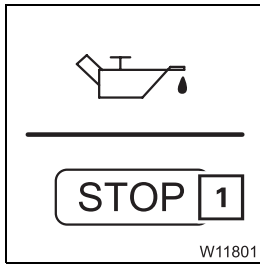

Current text:	Turning off the engine
----------------------	------------------------

A warning buzzer sounds and the lamp (1) lights up – the oil pressure is too low.

- Stop the truck crane as quickly as possible while observing the traffic situation and turn off the engine.
- Check the oil level; *Maintenance manual*
- Correct the oil level if necessary. If the warning message is still present, contact **CraneCARE**.



Risk of damage to the engine if the oil pressure drops

Turn the engine off as soon as possible and look for the cause if the lamp goes on or the warning buzzer sounds.

Never restart the engine before you have found the cause and eliminated the problem.

Error messages

This section provides information about different error messages.

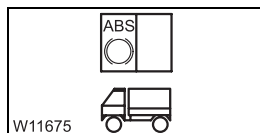

Current text:	No text
----------------------	---------

Malfunction in the truck crane ABS; *ABS system, p. 5 - 55.*

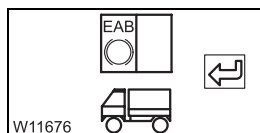

Current text:	Brake behaviour changed Look for a garage when possible
----------------------	--

Malfunction in the trailer ABS; *ABS system, p. 5 - 55.*



Current text:	Coolant temperature too high 115 °C
----------------------	-------------------------------------

The engine coolant is hotter than approx. 115° C (239 °F).

The engine capacity is automatically reduced.

Display of the current temperature; p. 4 - 17.

Possible cause and remedy; p. 7 - 23.



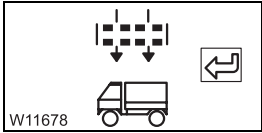

Current text:	Air filter dirty Service due
----------------------	---------------------------------

- Replace the air filter as soon as possible; *Maintenance manual*.

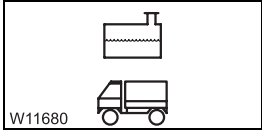

Current text:	Top up coolant
----------------------	----------------

- Immediately top up the coolant so that the engine does not overheat;
 Maintenance manual.

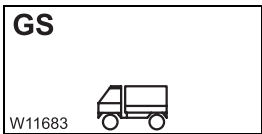

Current text:	Gear x: Shifting not possible
----------------------	-------------------------------

For x the affected gear **1 to 8** or **R** is shown. Transmission malfunction – the transmission no longer shifts.

- Stop the truck crane as quickly as possible while observing the traffic situation and turn off the engine.

Procedure in the event of malfunctions to the transmission and engine, p. 7 - 36.

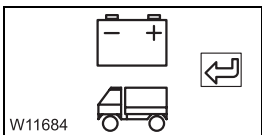

Current text:	V-belt / generator Find a garage
----------------------	-------------------------------------

The voltage in the carrier electrical system is too low.

- Stop the truck crane as quickly as possible while observing the traffic situation and turn off the engine.

Display of the current voltage; p. 4 - 18.



Current text:	Find a garage immediately
----------------------	---------------------------

At the same time, a warning buzzer sounds – the transmission of information to the *Driving* display and the instrument panel is faulty.

- Stop the truck crane as quickly as possible while observing the traffic situation and turn off the engine.
- Do not continue driving. Contact **CraneCARE**.

Risk of accidents due to unwanted malfunctions!

No further safety-related messages are shown.

You may only resume driving once the malfunction has been eliminated.

This avoids accidents caused by malfunctions which occur suddenly, e.g. when the parking brake engages because the supply pressure has become too low.



Information

This section provides information about different warning messages.

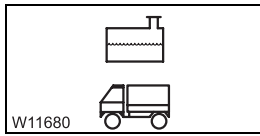

Current text:	Top up coolant as appropriate
----------------------	-------------------------------

Top up coolant at the next opportunity; *Maintenance manual*.

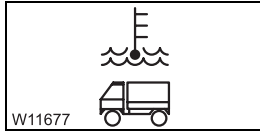

When the coolant has overheated, there are different options available:

Current text:	Coolant temperature too high 100 °C
----------------------	-------------------------------------

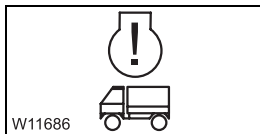

Current text:	Engine protection: capacity reduced
----------------------	-------------------------------------

The engine coolant is hotter than approx. 100 °C (212 °F).
Display of the current temperature; p. 4 - 17.
Possible cause and remedy; p. 7 - 23.

ABS system

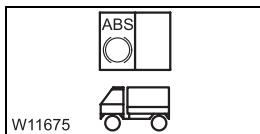

Different messages are given when there is a malfunction in the ABS system:

Current text:	Function restrictions possible
----------------------	--------------------------------

Malfunction in the truck crane ABS

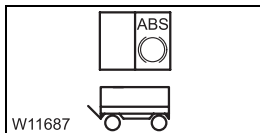

Current text:	Malfunction in the trailer ABS
----------------------	--------------------------------

Malfunction in the trailer ABS

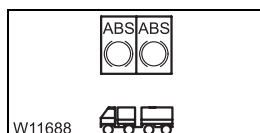

Current text:	Function restrictions possible
----------------------	--------------------------------

Malfunction in the truck crane and trailer ABS

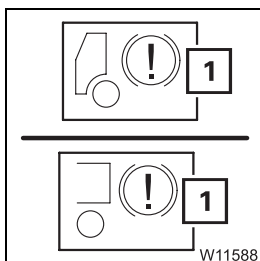

The corresponding lamp (1) lights up.
The ABS system shown can no longer prevent the wheels from being blocked. The full braking force remains intact. Drive with particular care and avoid braking fully if at all possible.

- Have the defective ABS system checked over; *Service brake malfunctions*, p. 7 - 26.



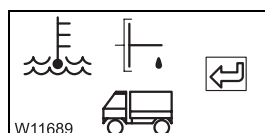

Current text:	Clutch: Overload Allow the clutch to cool down
----------------------	---

Remove your foot from the accelerator immediately and actuate the service brake; *Warning when starting*, p. 5 - 33.



Current text:	No text
----------------------	---------

Malfunction to the drive control. The engine capacity is reduced, and the accelerator may not function.

- Stop the truck crane as quickly as possible while observing the traffic situation and turn off the engine.

Procedure in the event of malfunctions to the transmission and engine, p. 7 - 36.



Current text:	Top up diesel
----------------------	---------------

The fuel tank is almost empty.

- Refuel before the fuel is used up; p. 4 - 7

When the fuel tank is almost empty, air is sucked in and you must bleed the fuel system; *Maintenance manual*.

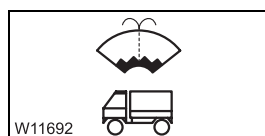

Current text:	Top up with washing water as required
----------------------	---------------------------------------

The windscreen washing system tank is almost empty.

- Top up the tank in good time; p. 5 - 6.



Current text:	Retarder cannot be switched off Find a garage
----------------------	--

The retarder cannot be switched off when the accelerator is actuated or while the ABS is active.

Drive carefully and arrange for the cause to be remedied as quickly as possible.



Current text:	Apply the parking brake
----------------------	-------------------------

- Engage the parking brake; ■■■▶ p. 3 - 44.

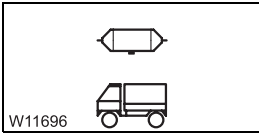

Current text:	Supply pressure in the auxiliary consumers too low
----------------------	--

The message is also displayed on the *ECOS* display; ■■■▶ *Supply pressure in secondary consumers too low*, p. 5 - 49.



Engine electronics

Malfunction in the engine electronics; the power is reduced; ■■■▶ p. 7 - 23.

41005067

5.3.9 Turning off the truck crane

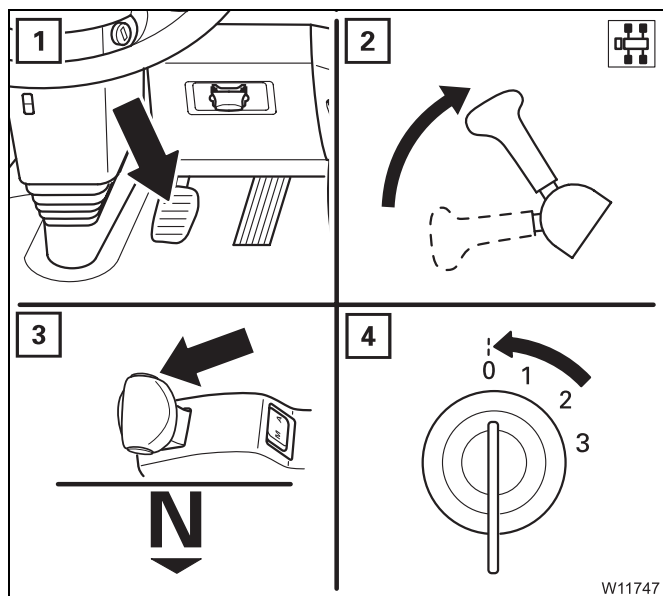

To turn off the truck crane, you must

1. Stop the truck crane
2. Apply the parking brake
3. Switch to neutral position; p. 5 - 30
4. Turn off the engine; p. 4 - 21

Secure against rolling away



The number of fold-up wheel chocks supplied varies according to the specifications in the country of use.

Risk of accidents due to the truck crane moving unintentionally

Secure the truck crane on uphill and downhill roads by using wheel chocks together with the parking brake.

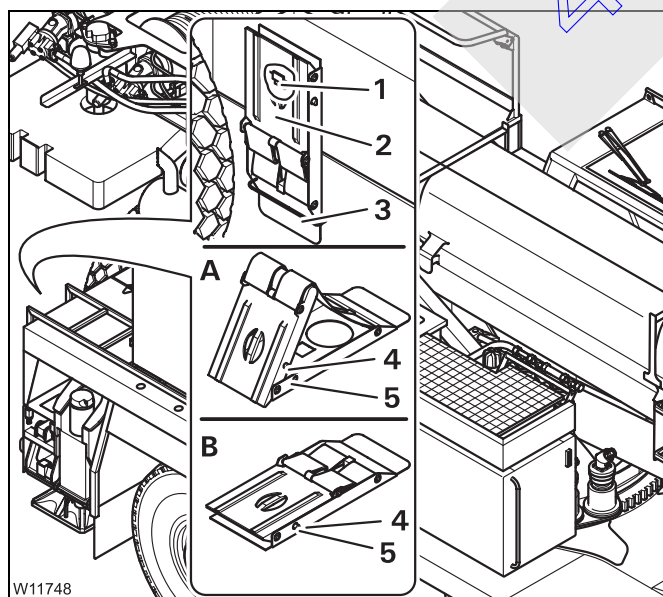

Transport at the rear of the carrier

- Push the chock (2) behind the bracket (3) and hang it on the holder (1).

(A) – folding out

- Press the locking bar (4) through the bore (5).

The chock folds out by spring force.

(B) – folding up

- Press the chock together until the locking bar (4) engages in the bore (5).

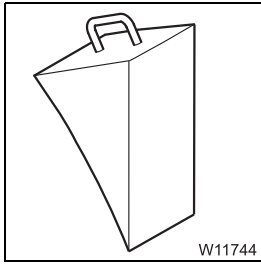

Additional chocks cannot be folded up, and can be transported in the storage compartments.

**When stationary
for more than
8 hours**

- Switch off all current consumers, e.g. auxiliary heaters
- Turn off the engine.



In order to prevent malfunctions, you should only switch off the main battery switch when the engine has been switched off.

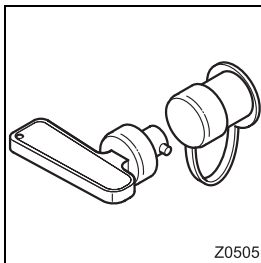

- Switch off the battery master switch

Securing the truck crane against unauthorised use

- Secure the truck crane against unauthorised use by
 - Stowing away the hand-held control in the crane cab or in the driver's cab
 - Removing the ignition key and
 - Locking the driver's cab and the crane cab



Danger due to unauthorised use

Always stow away the hand-held control in the crane cab before leaving the truck crane, and lock the door to the crane cab or the driver's cab. In this way you can prevent unauthorised persons from starting the engine with the hand-held control.

Blank page

41005067

5.4

Off-road driving

This section describes adjustments, connections and procedures for adapting the vehicle handling to off-road conditions.

Adjustments to the transmission

If you drive continuously, for short periods of time with different loads or on a slippery surface, the transmission may switch gears too late or too early. In this case you can make the following adjustments:

- Shift to a lower starting gear; ■■■▶ p. 5 - 32.
- Step on the accelerator as far as it will go when starting – starting mode for load on.
- Select the *Manual* operating mode. In this way you will be able to drive carefully and shift gears on time; ■■■▶ *Changing the operating mode*, p. 5 - 30.

Connections

If the adjustments to the transmission are insufficient on their own, you can additionally connect the following one after the other:

- First, you can switch on the **off-road gear** in the transfer case; ■■■▶ p. 5 - 62.
- Then switch on the **longitudinal differential locks**; ■■■▶ p. 5 - 63.
- Then switch on the **transverse differential locks**; ■■■▶ p. 5 - 63.

Changing the vehicle level

You can also adapt the truck crane to the off-road inclination using the level adjustment system, or lift and lower the truck crane; ■■■▶ p. 5 - 65.

Rocking the vehicle free and towing

If the truck crane is stuck in terrain; ■■■▶ *Freeing the truck crane stuck in terrain*, p. 5 - 69.

5.4.1

Transfer case – off-road gear on / off

The off-road gear increases the thrust of the driven wheels.

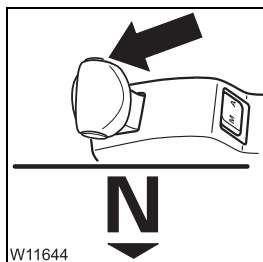

Prerequisites

- Stop the truck crane
- Select neutral on the transmission.
- If required, open the main menu .

Switching on / off

After switching on, the speed is limited to approx. 20 km/h (12 mph).

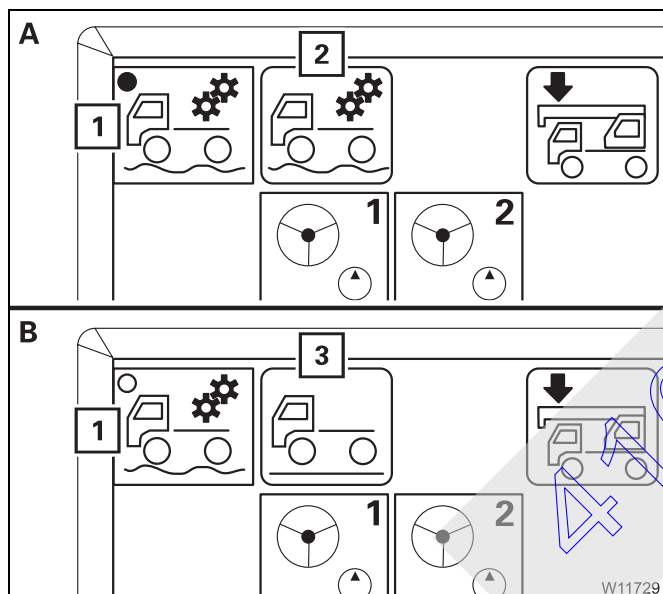

- Press the button (1) repeatedly until
 - (A) The dot turns green – symbol (2) displayed, off-road gear on.
 - or
 - (B) The dot turns black – symbol (3) displayed, off-road gear off.

If the symbol (2) or (3) is not shown, select a starting gear on the transmission and shift back into neutral, or start up slowly.

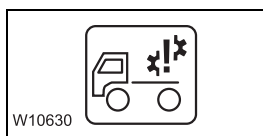

If the error symbol is displayed, contact **CraneCARE**.

Neutral position

For towing away, you can also switch the transfer case to the neutral position;  p. 7 - 8.

5.4.2

Longitudinal and transverse differential locks

- The longitudinal differential locks prevent individual axle lines from spinning when driving on a slippery surface. With the 8 x 8 x 8 drive, the second axle line drive is switched on and off.
- The transverse differential locks prevent individual wheels from spinning when driving on a slippery surface.

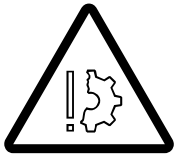

Risk of damage to the differential locks

Leave the transverse differential locks switched on only for as long as necessary. Always switch off the transverse differential locks before driving on a firm surface.

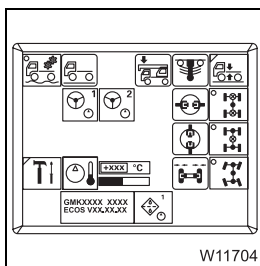

- Stop the truck crane
- Straighten the steering
- If required, open the main menu 

To switch on and off, the current speed must be below approx. 5 km/h (3 mph).

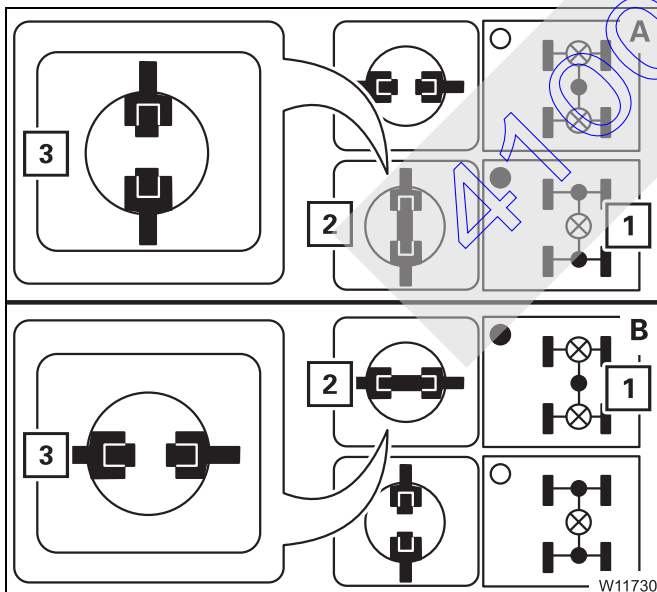

Switching on

- Press the button (1) for the
 - longitudinal differential locks (A) or
 - transverse differential locks (B)
 The dot turns **green**.
- Start up slowly – display:
 - The symbol (3) first turns yellow
 - The symbol (2) then – **red**.
 Differential locks on.

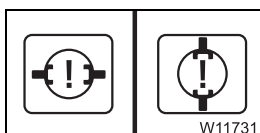

If the error symbol is displayed, contact **CraneCARE**.



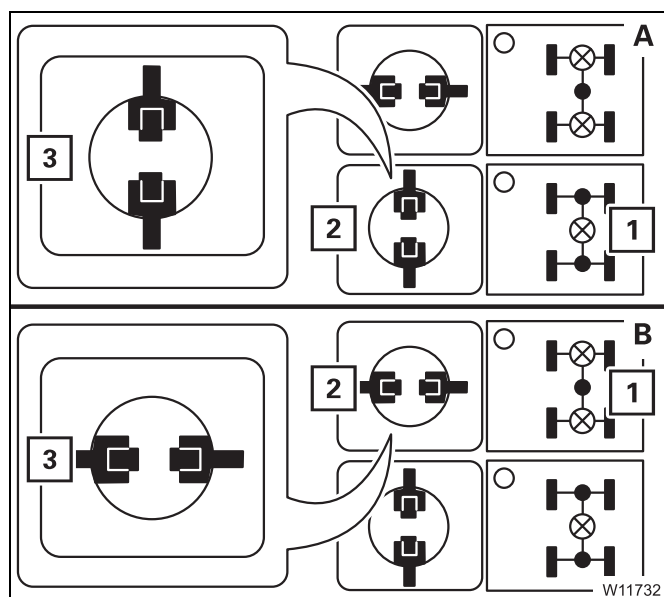

Switching off

- Press the button (1) for the
 - longitudinal differential locks (A) or
 - transverse differential locks (B)The dot turns **black**.

Display:

- The symbol (3) first turns yellow
 - The symbol (2) then – **green**.
- Differential locks off.

If the symbol (2) is not shown, drive forwards and backwards slowly.

41005067

5.4.3

Operation of the level adjustment system

You can use the level adjustment system to set the on-road driving level, change the overall level and incline the truck crane.

Opening the submenu

You can only open the *Level adjustment system* submenu when the current speed is below approx. 5 km/h (3 mph).

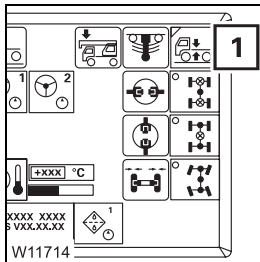

- If necessary, open the main menu  and press the button (1) once.

The *Level adjustment system* submenu opens.

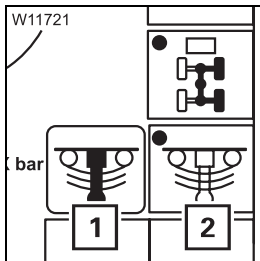

- Check that the symbol (1) is **green** (suspension on)
- If the symbol (1) is red, press the button (2) once to switch on the suspension

When the suspension has been switched on, you can

- Set the on-road driving level or
- Pre-select the suspension struts and change the vehicle level

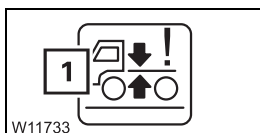

If the symbol (1) for an error is shown, contact **CraneCARE**.



Setting the on-road level

For on-road driving, you must always set the on-road level in order to adhere to the specified overall height.

- Park the truck crane on a level surface
- Straighten the steering
- Press the button (1) until the symbol (2) turns **green**.

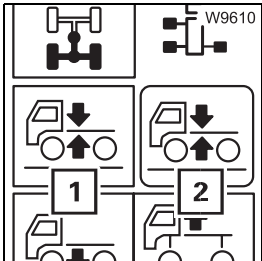

The display first shows the  symbol in **yellow** and when the on-road level has been reached, it shows the symbol (2) in **green**.

Pre-selecting suspension struts

You can pre-select the suspension struts for five different level changes.

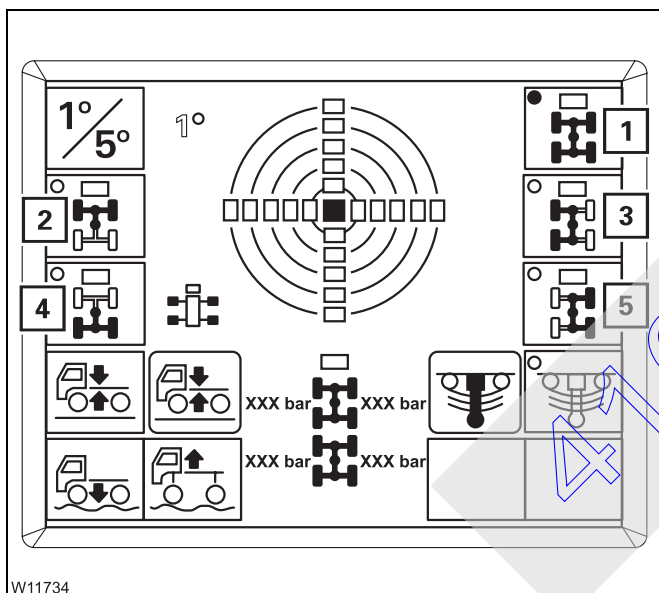

- For a uniform level change

- 1 Overall level – all suspension struts

- For inclination

- 2 Front level – suspension strut for the first and second axle line
- 3 Left level – all suspension struts on the left
- 4 Rear level – suspension struts for the third and fourth axle line
- 5 Right level – all suspension struts on the right

- Press the button next to the required symbol once – the dot turns **green**, e.g. for symbol (1).

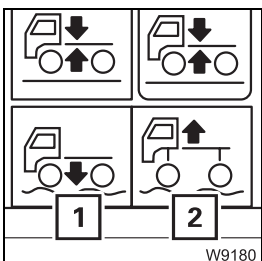

The corresponding suspension struts remain pre-selected for approx. 5 seconds.

During this time, the symbols (1) and (2) are **black** and the corresponding buttons are active.

Changing the vehicle level

You can extend or retract the pre-selected suspension struts to change the vehicle level.



Risk of accidents from exceeding the permissible overall height

Always bring the truck crane to on-road level before driving on roads after changing the level.

If the truck crane is on a higher level, then the specified overall height will be exceeded.

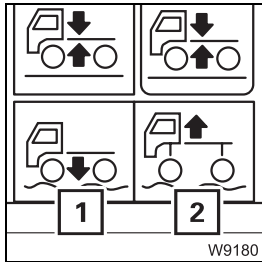

Lower level

- Press the button (1).
The pre-selected suspension struts retract.

Raise level

- Press the button (2).
The pre-selected suspension struts extend.

The level is continuously changed until you release the button or the end position is reached.

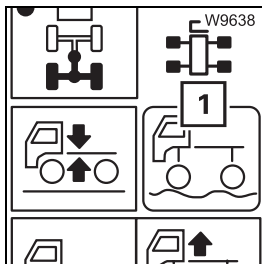

During the entire procedure, the symbol for the current state is shown, e.g. after the truck crane is inclined, the symbol (1) – *No on-road level* is shown.

Viewing the current inclination

The inclination indicator shows the current alignment.

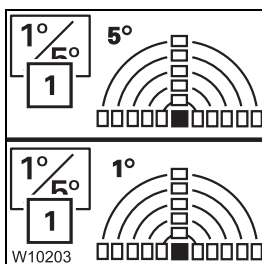

Switching over the measuring range

You can change the measuring range between 1° and 5°.

- Press the button (1) once.
The current measuring range is displayed.



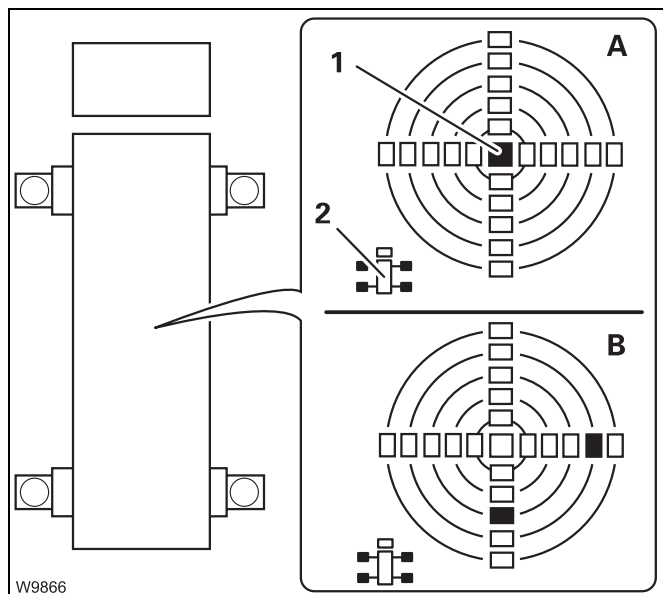

(A) – When the truck crane is level, only the lamp **(1)** in the middle lights up.

The other lamps show the sides of the truck crane which are higher.

The assignment to the carrier is given by the directional indicator **(2)**.

(B) – In this example, the carrier would be standing higher to the rear on the right hand side.

Exiting the submenu

You can exit the *Level adjustment system* submenu at any time.

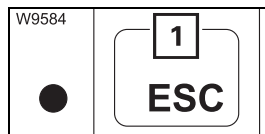

- Press the button **(1)** once.

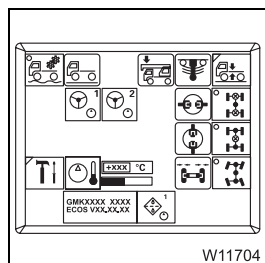

The main menu opens.

The *Level adjustment system* submenu automatically closes as soon as the current speed rises above approx. 5 km/h (3 mph).

5.4.4

Freeing the truck crane stuck in terrain

Rocking the truck crane free

If the truck crane is stuck in terrain, you can try to free it by driving back and forth (rocking it free):

If you are trying to rock the crane free, you should switch on the transverse differential locks and the longitudinal differential locks.



When rocking the truck crane free, always press the accelerator as far as it will go in order to activate the Load starting mode.



Always begin with the *Reverse driving direction R*. Otherwise direct gear shifting without neutral position is not possible.

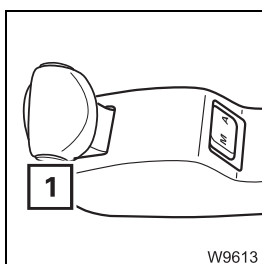

- Select the reverse driving direction **R**
- Drive as far as possible up to the highest point and then let go of the accelerator
- Press the button **(1)** and additionally push the switch lever forwards once The first gear is engaged
- Drive as far as possible up to the highest point and then let go of the accelerator
- Press the button **(1)** and additionally push the switch lever backwards once The reverse gear **R** is selected
- Drive as far as possible up to the highest point and then let go of the accelerator
- Keep on driving back and forth to rock the crane free, changing gears directly



Towing free forwards



- Fasten a steel rope to the front towbar coupling.

Risk of damage to the chassis

Only tow the truck crane free while observing the procedure given for the pulling direction.

Jerking the truck crane or pulling it at an angle can cause damage to the chassis.

The front towbar coupling is designed for a maximum tractive force of 100 kN (approx. 10 t) (22,480 lbf (approx. 22,050 lbs)), when:

- The direction of pull runs forward along the longitudinal axle or at an angle of 45° to the right or left of the longitudinal axle **and**
- The direction of pull runs along the longitudinal axis towards the rear without diverting up or down

Towing free in reverse gear



- Fasten a steel rope to one of the towing eyes on the rear chassis wall using a shackle on a towing eye.

Risk of damage to the chassis

Only tow the truck crane free while observing the procedure given for the pulling direction. Otherwise the chassis may be damaged or the towing eyes may be torn off or bend.

The towing eyes on the vehicle tail or the ROB are designed for a maximum tractive force of 75 kN (approx. 7.5 t) (16,860 lbf (approx. 16,530 lbs)) when:

- The direction of pull runs along the level of the longitudinal axle **and**
- The direction of pull runs along the longitudinal axis towards the rear without diverting up or down

5.4.5

Separate steering

There are two types of steering with separate steering.

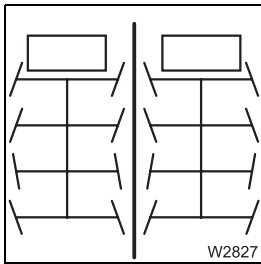

– Driving around corners:

When the separate steering is switched on, the steering angle is larger than for normal steering mode, and the turning circle is smaller.

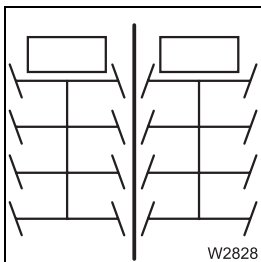

– Crab travel:

When the separate steering is switched on, the truck crane drives sideways if you turn the wheels of the front and rear axle lines in the same direction.

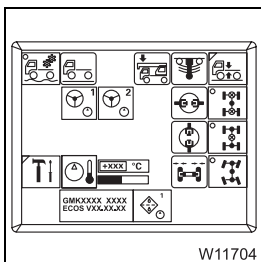

- If required, open the main menu .

Switching to separate steering

- Always switch to separate steering when
- Driving with the rigged truck crane or
 - Steering at low speed



Risk of accidents when driving on the road with unlocked steering

After driving with separate steering, change over immediately to normal steering. The locking status for normal steering mode is only restored once the green *Locked* symbol  is displayed.

You can only change over to separate steering when the current speed is below approx. 5 km/h (3 mph).



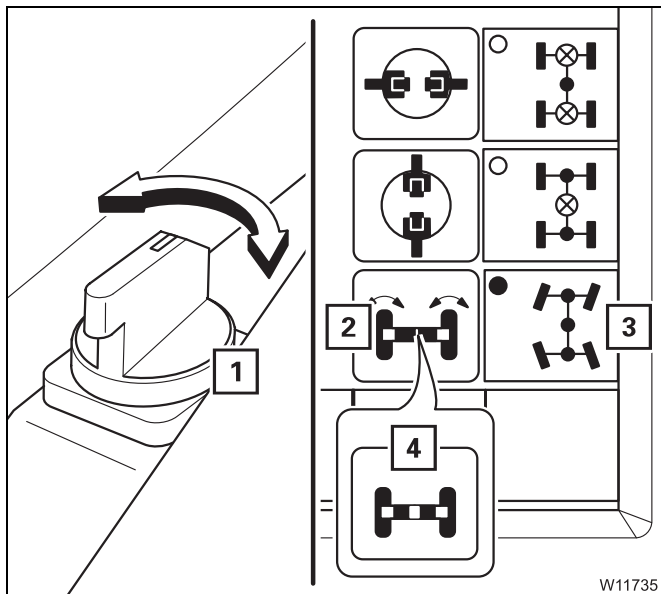

- Press the button (3) once – dot **green**.

If the fourth axle is unlocked – symbol (3) **yellow**:

- Using the button (1), steer until the third and fourth axle line have the same steering angle.

When the connection between the third and fourth axle line engages, the system switches to separate steering – symbol (2) **red**.

The speed is now limited to approx. 20 km/h (12 mph).



If the error symbol is displayed, contact **CraneCARE**.

Steering

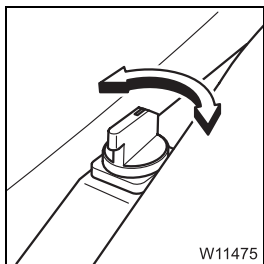

- Steer the first and second axle line with the steering wheel.
- Steer the third and fourth axle line with the button (1).
 - **To turn to the left:**
 - Push the button to the left.
 - **To turn to the right:**
 - Push the button to the right.

The axle line is steered as long as you keep the button pressed or until an end position is reached.

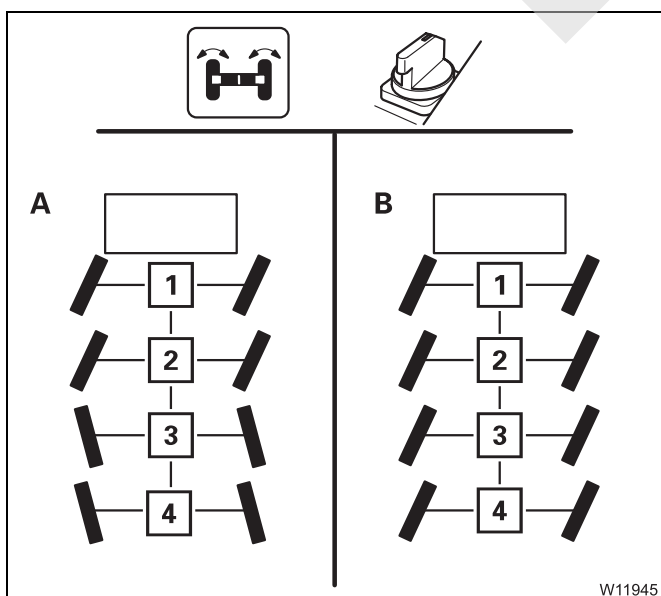

(A) – for driving around corners

- Steer the third and fourth axle line in the opposite direction to the first and second axle line.

(B) – for crab travel mode

- Steer the third and fourth axle line in the same direction as the first and second axle line.

Switching to normal steering mode

- Steer the first and second axle lines as far as possible to the right or left and keep them in this position until the switching operation is over.

The switching operation does not start before the wheels of the front axle lines are turned as far as they will go.



Risk of accidents when driving on the road with unlocked steering

Switching to normal steering is only completed once the green *Locked* symbol  is displayed. Otherwise, the locking procedures are not yet completed.

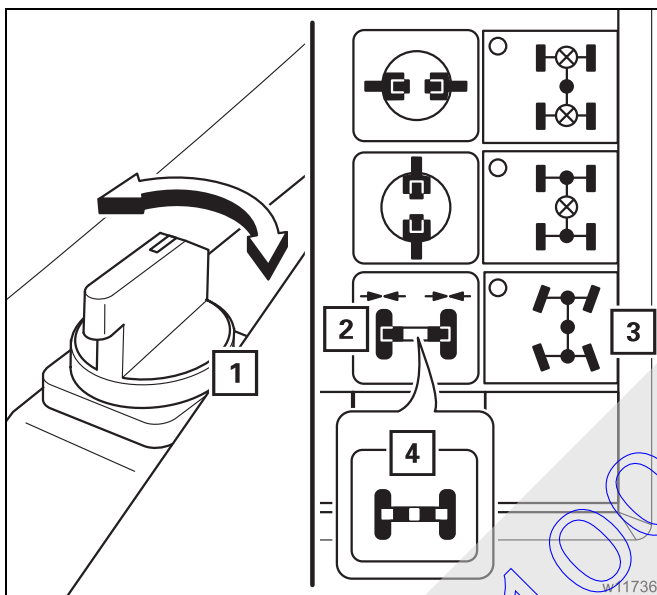

- Press the button (3) once – dot **black**.
- Use the button (1) to steer the rear axle lines in the opposite direction of the front axle lines until the symbol (4) is **yellow**.

The second and fourth axle lines are now connected.

- Use the button (1) to steer the third axle line into the straight position until the symbol (2) is **green**.

The third axle line is now locked and the system is switched to normal steering.



If the error symbol is displayed, contact **CraneCARE**;  p. 7 - 27.

Blank page

41005067

5.5

Heating and air-conditioning system

5.5.1

Standard heating system

Switching on

- Start the engine. The heating output is only provided when the engine is running.

Heating

You must set the blower and the temperature.

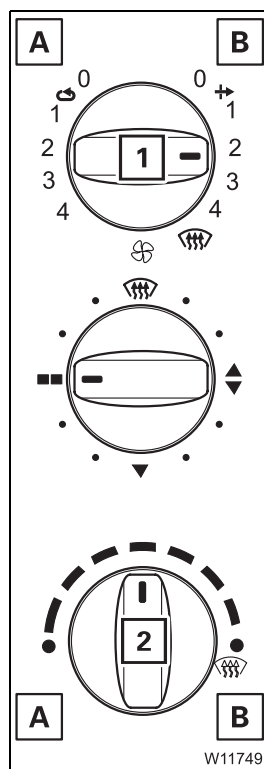

Setting the blower / recirculated / fresh air

You can regulate the air volume with the switch (1) for

- A** Recirculated air – air is sucked in from the driver's cab. Change to fresh air every so often to ensure that oxygen is supplied.
- B** Fresh air – air is sucked in from outside.

- Turn the switch (1) to the required level 1 to 4, Recommended – level 2.

Setting the temperature

- Turn the switch (2) to the required position
 - A** colder
 - B** warmer
- Press the switch (2) several times in succession at least once a month in order to prevent functional errors.



Air distribution

You can arrange for the air to flow out of different air vents.

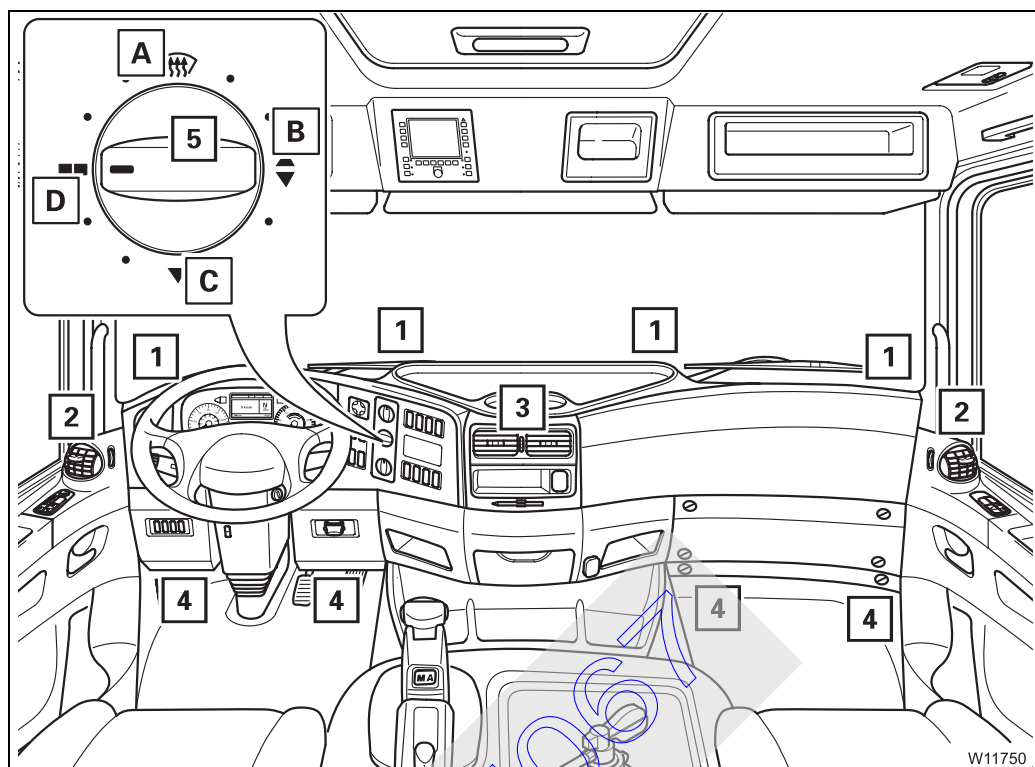

- Turn the switch (5) to the position for the required air vents.

- A Air vents (1), (2) – front windscreen, side
- B Air vents (1) to (4)
- C Air vents (2), (3), (4) – side, centre, below
- D Air vents (2), (3) – side, centre

Air vents (2) and (3) can be set.

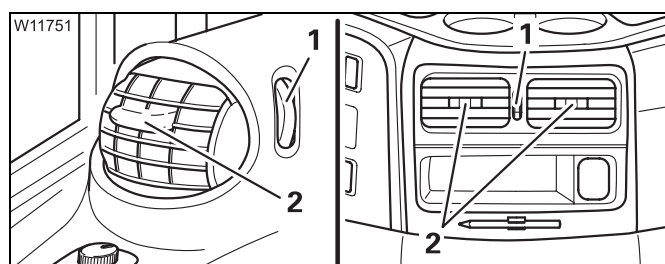

Adjusting the air vents

- 1 – To open: upward
– To close: press down the switch
- 2 To direct the air flow

Examples

This section only contains setting examples.
Always adjust the setting to the current conditions (warm, cold, damp).

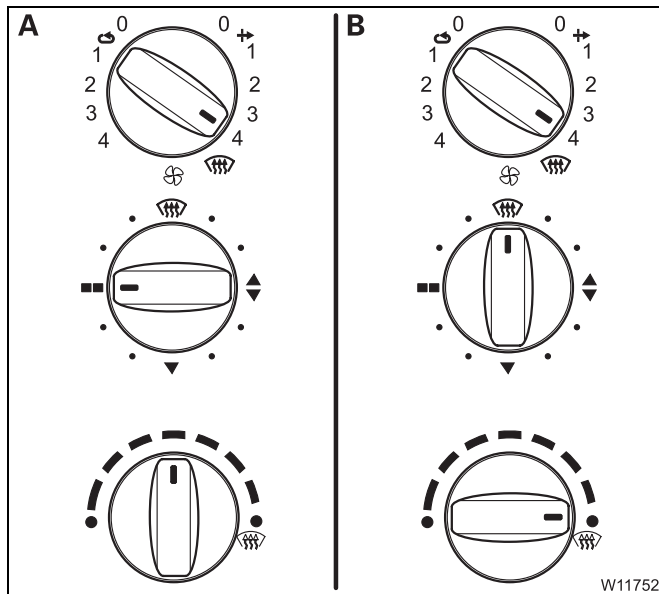

(A) – ventilation

- Turn the switch into the positions shown.
- If necessary, open the air vents for the side and centre.
- If necessary, open the push-up roof;
 p. 3 - 56.

(B) – Defrosting the front windscreen

- Turn the switch into the positions shown.
- Close the air vents for the side and centre.

Switching off

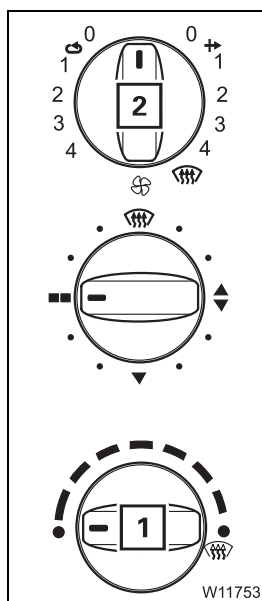

Switching off the heater

- Turn the switch (1) anti-clockwise as far as it will go to *cold*.

Switching off the ventilation

- Turn the switch (2) to level 0.

5.5.2 Air-conditioning system

You can cool the driver's cab and dry the air using the air conditioning system.

Warnings

Do not cool the air too strongly.

The difference between the outside temperature and the inside temperature should be at the most 10 °C to 14 °C (18 °F to 25 °F).

If cooling is too severe, you may frequently feel physically uncomfortable, usually only after you leave the cool room.

Avoid having cold air blowing directly onto your body.

When using recirculated air, you should switch over to fresh air mode to ensure a fresh supply of oxygen at the same time. Adjust the cooling output to your actual needs:

If the truck crane has been exposed to strong sunlight for a long period of time, for example, the air conditioning system should initially be operated at the highest blower level with the engine running.

The door or at least the windows should be left open for a short while to air thoroughly. The cooling-down procedure can be accelerated by increasing the engine speed.

If the air-conditioning system is operated continuously, close the windows and doors to ensure sufficient cooling.

Set the fan to a lower level once the inside temperature has reached the desired temperature.

Switching on / off

- Start the engine. The air conditioning only functions when the engine is running.
- Switch off the auxiliary heater;  p. 5 - 84.

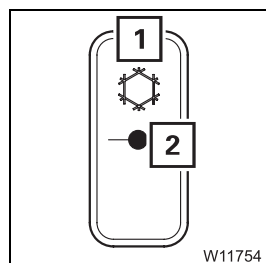

- **To switch on:**
 - Press the button (1) up – the lamp (2) lights up.
- **To switch off:**
 - Press the button (1) down – the lamp (2) goes out.

Cooling

The illustration only shows a sample setting. Always adjust the setting to the current conditions.

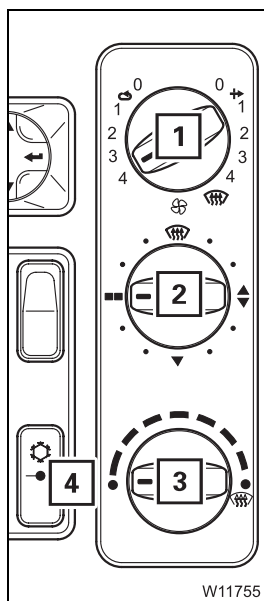

- Switch the air conditioning on – the lamp (4) lights up.
- Turn the switch (3) as far as it will go to *cold*.
- Turn the switch (1) to the required level – with recirculating air, you will be able to cool more quickly, but no oxygen is fed in.
- Use the switch (2) to set the air distribution – open the air vents if necessary; ►► p. 5 - 76.
- Close the push-up roof; ►► p. 3 - 56.

Drying

You can dry the air in the driver's cab.

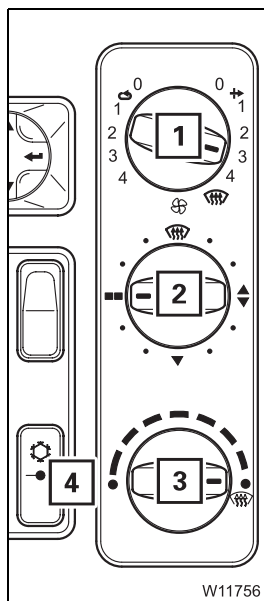

- Switch the air conditioning on – the lamp (4) lights up.
- Turn the switch (3) as far as it will go to *warm*.
- Turn the switch (1) to the required level – adjust the fresh air / recirculating air setting to the current conditions (humidity and temperature of the outside air).
- Use the switch (2) to set the air distribution – open the air vents if necessary; ►► p. 5 - 76.
- Close the push-up roof; ►► p. 3 - 56.

When drying, the air conditioning and the heating work against each other. After drying, switch off the device you do not require.

5.5.3

Auxiliary heater

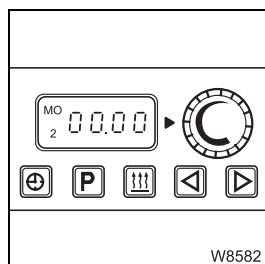

You can use the auxiliary heating to preheat the driver's cab or provide additional heating.

The auxiliary heater is supplied from the fuel tank.



The batteries will run down if you operate the auxiliary heater with the engine switched off. You must recharge the batteries at shorter intervals if you use the auxiliary heater frequently.

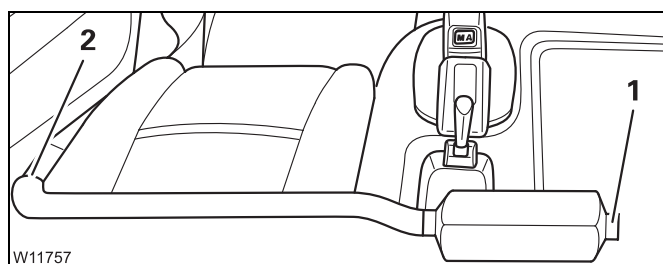

Do not cover the openings for the air intake (1) and air outflow (2).

Switching on

- Before switching on the heater, check whether it is allowed to be operated at the current site of the truck crane. Find out whether there are any sources of danger that could result in explosions.



Danger of explosions when operating the heater

The heater must not be operated:

- At service stations and tank farms
- At places where inflammable gases or vapours can be found or may form (e.g. at places where fuel is stored and at chemical factories)
- At places where explosive dust can be found or form (e.g. coal dust, wood dust, grain dust)



Danger of suffocation when operating the heating

Do not operate the heater or the heater with the timer in enclosed rooms (e.g. garages).



This section describes how to switch on the heater manually. You can also have the auxiliary heater switch on automatically; *Storing the heating start*, p. 5 - 82.

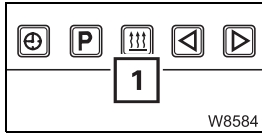

- Turn on the ignition; *Switching on the ignition*, p. 4 - 9.
- Press the button (1) once.
The auxiliary heating switches itself on and the control field lights up.



Always switch off the auxiliary heater when you turn off the truck crane when the battery master switch is switched on. In this way, you prevent the auxiliary heater from restarting and running down the batteries after the engine has cooled down.

Temperature

You can preselect a temperature. The preselected temperature is automatically set and maintained.

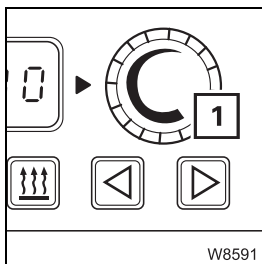

Increasing the temperature:

- Turn the switch (1) clockwise

Reducing the temperature:

- Turn the switch (1) anti-clockwise

The higher the selected temperature is, the faster the fan of the auxiliary heater runs.

Setting the day and time

Always set the current time and weekday. These settings are required for the correct activation point of the automatic heating start.



If the power supply is interrupted, all symbols in the display will flash and you must set the time and day again.

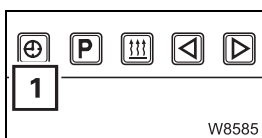

- Press the button (1) for longer than 2 seconds.
The displayed time flashes, e.g. 10.00 hrs.



Set the current time on the flashing display, e.g. 14.00 hrs.



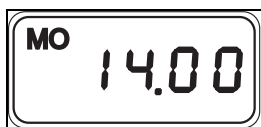

- Wait five seconds. The new time is saved and then the weekday flashes (e.g. **MO** for Monday).



- Set the current day of the week on the flashing display.

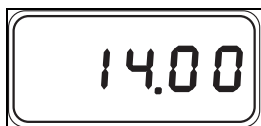

The display stops flashing after five seconds and the current time is displayed. The day of the week disappears.

The time and day of the week have been set.

Storing the heating start

The automatic heating is only started at the required time when the time and day of the week have been set correctly; p. 5 - 81.

You can set three different automatic heating starts – up to seven days in advance.



If you call up values in order to change them during the following setting procedure, they flash for five seconds. The entry must be made within this period of time. The value stops flashing after five seconds and is saved as the new value.

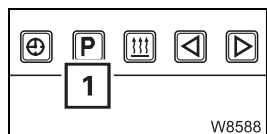

- To retrieve a storage location, press the button (**1**) once.

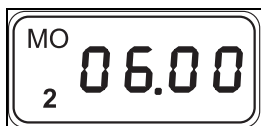

Flashing displays:

- The retrieved storage location, e.g. 2 and
- The heating start stored last, e.g. 6.00 am.



- Set the time for the required heating start, e.g. 8.00 am.



Wait for approx. 5 seconds until the day of the week for the heating start flashes, e.g. **MO** for Monday.



- Set the day of the week for the required heating start.

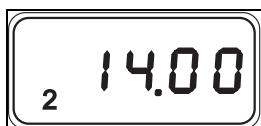

Wait for approx. 5 seconds until the current time is shown, e.g. 14.00 hrs. Now the new heating start has been stored and switched on.



If you wish to store one or two further heating starts, retrieve a new storage location using the **P** button and repeat the procedure.

After you have stored the heating start, you can also set the heating period;
▶▶▶ *Setting the heating period*, p. 5 - 83.

Setting the heating period

After an automatic start, the auxiliary heating switches itself off as soon as the set heating period has elapsed.
The heating period applies to all stored heating starts.

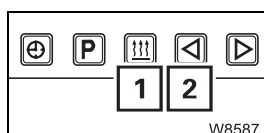

- Switch off the auxiliary heating using the **(1)** button.
- Press the button **(2)** for longer than 3 seconds.



The last set heating period, e.g. 27 minutes, now flashes for 5 seconds in the display.



- Set the required heating period on the flashing display. You can set a heating period of 10 to 120 minutes.

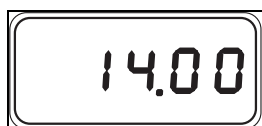

Wait for 5 seconds until the current time is shown, e.g. 14.00 hrs.
A new heating period has now been set.

Switching the heating start on and off

To switch on an automatic heating start, you must retrieve the corresponding storage location.

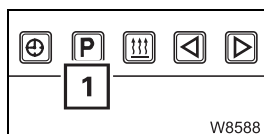

- To retrieve a storage location, press the button **(1)** once.

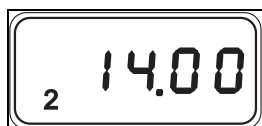

The display flashes for 5 seconds and a storage location is shown (e.g. **2**).
The heating start at this storage location is now activated.

To activate a different heating start, press the **P** button repeatedly until the required storage location is displayed. This heating start is activated as soon as the display stops flashing.





To deactivate the automatic heating start, press the **P** button repeatedly until no storage location is displayed any longer.

Switching off

This section only describes how to switch off the heater manually. The auxiliary heater is switched off after a set heating period if it was switched on automatically. **Setting the heating period**, p. 5 - 83.

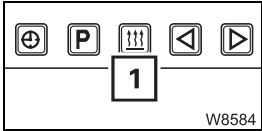

- Press the button **(1)** once. The auxiliary heater is switched off immediately.



If you turn off the ignition while the auxiliary heater is in operation, the auxiliary heater continues to run for a certain period of time. You can set this remaining time; **Setting the remaining time**, p. 5 - 84.

Setting the remaining time

If the ignition is turned off while the auxiliary heater is running, the auxiliary heater continues to run for the remaining time.

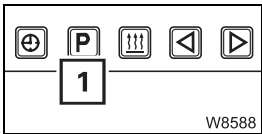

- Switch on the auxiliary heating using the **(1)** button.

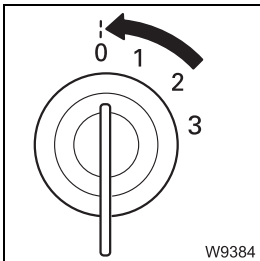

- Turn off the ignition.



The auxiliary heating continues to run and the residual run time set last flashes, e.g. 48 minutes.



- Set the required remaining run time on the flashing display. You can set a remaining run time of 1 to 120 minutes.

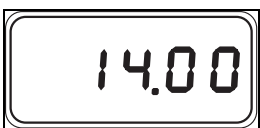

- Wait for 5 seconds until the current time is shown. The remaining run time is now set.

5.6

Towing a trailer

When towing a trailer, a towbar coupling is fitted to the back of the carrier.

Please observe the permissible trailer load of your truck crane.



Risk of accidents posed by trailer moving unintentionally

Before coupling or uncoupling the trailer, it must be secured with the trailer parking brake as well as with chocks to prevent it from rolling away. Ensure that it is still possible to swivel the front axle of the trailer.



Before coupling the trailer, adjust the towbar to the height of the towbar coupling.



Risk of accidents when coupling the trailer

No one may be between the truck crane and trailer when coupling the two vehicles.



Risk of accidents due to unexpected acceleration

When you move slowly towards the trailer, the transmission automatically shifts into manoeuvring mode. If the warning buzzer sounds, release the accelerator **immediately**.

If you do not release the accelerator, the electronics will couple automatically within a few seconds. The truck crane could accelerate unexpectedly and people might be crushed between the trailer and the truck crane.



Please observe the relevant national regulations regarding coupling and uncoupling of the trailer

Effects on the axle loads

Observe the effects on the axle loads when towing a trailer. The axle loads of your truck crane change in the following manner when operating with central axle trailers:

- For every 100 kg (220 lbs) of drawbar load, the axle loads on the 1st and 2nd axle lines are reduced by 37 kg (82 lbs).
- For every 100 kg (220 lbs) of drawbar load, the axle loads on the 3rd and 4th axle lines are increased by 87 kg (192 lbs).



Coupling the trailer



Risk of injury when the automatic closing device is triggered

Do not put your hand into the coupling jaw when the towbar coupling is open.

This may activate the automatic closing device, causing the coupling pin to move down with great force, seriously injuring your hand.

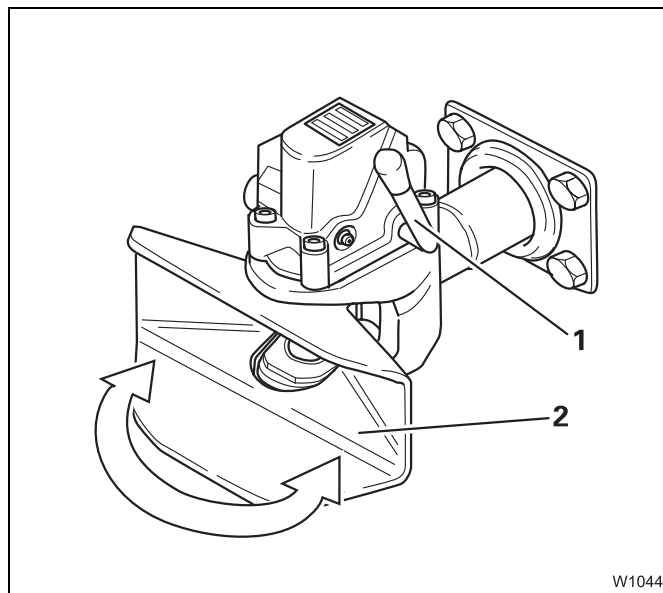

- Open the towbar coupling. Push the lever (1) up until it latches into place.
- Check whether the coupling jaw (2) is stable. It may not be allowed to move to the left or the right when the towbar coupling is open.
- Carefully drive the truck crane backwards so that the towbar of the trailer is pushed into the coupling jaw.

The towbar coupling closes automatically, and the lever (1) swings downwards.



Make sure you check the prescribed condition of the coupling after each coupling procedure.

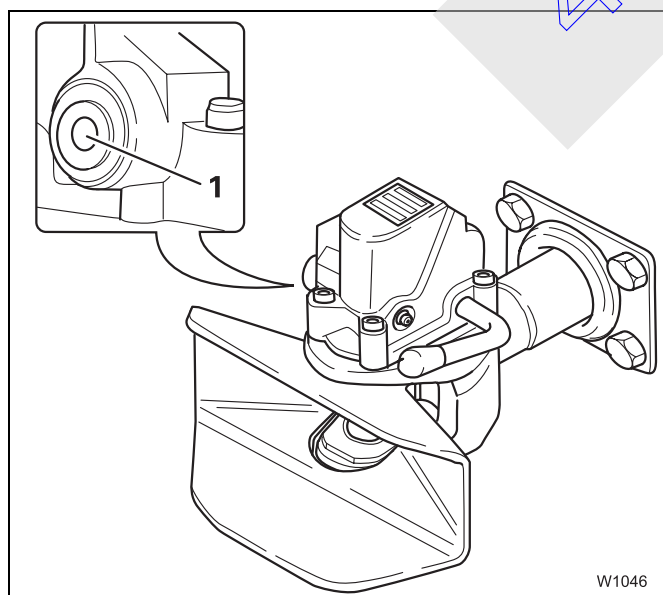

The pin (1) may no longer protrude from the guide bushing after the coupling procedure.



Risk of accidents if the trailer is coupled improperly

If the pin is protruding from the guide bushing, the trailer is not coupled properly and could become disengaged from the towbar coupling while driving.

Connecting the supply lines

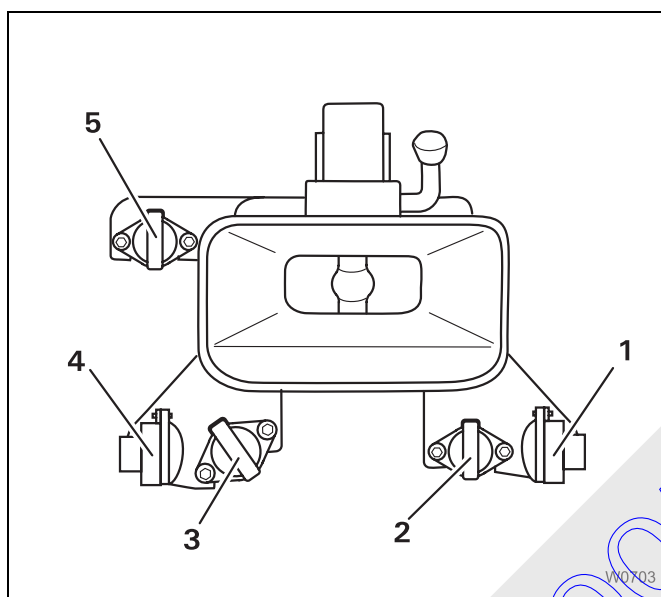

- Insert the plug of the trailer's electrical system into the socket (5).
- If necessary, insert the ABS connection cable into the socket 3).
- First connect the hose of the brake cable to the yellow coupling head (4).
- Then connect the hose of the supply line to the red coupling head (1).

This socket (2) is designed for special equipment.



Risk of accidents if the hoses are too short or installed improperly

The hose lines may not come off even when driving around corners. When connecting the hoses, make sure they are long enough and have enough clearance.

- Check the function of the trailer lighting.
- Test the service brake and parking brake immediately after setting off.



Removing the supply lines



Risk of accidents due to trailer moving unintentionally

Always first remove the hose from the supply line so that the trailer is braked. This prevents the trailer from moving when you remove the brake hose.

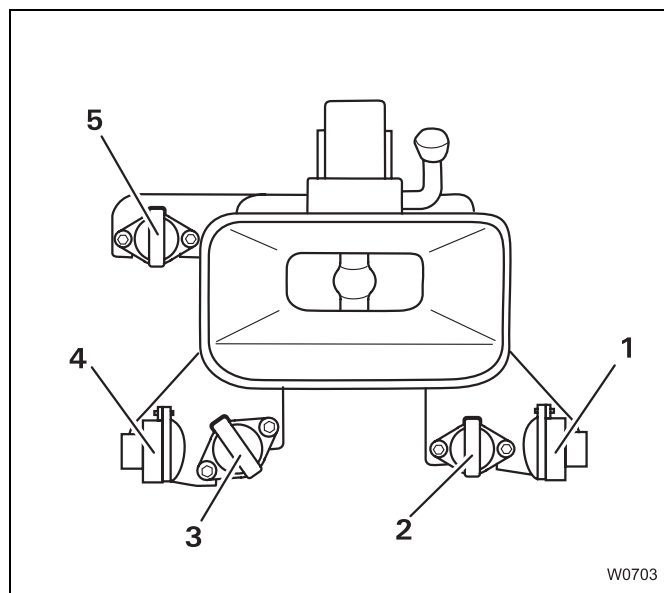

- Proceed as follows:
 - First disconnect the hose of the supply line from the red coupling head (1). Now the trailer is braked.
 - Then disconnect the hose of the brake line from the yellow coupling head (4).
- Remove the plug (5) of the trailer electrical system from the socket.
- If necessary, remove the plugs (2) and (3) from the sockets (ABS and special fittings).

Uncoupling the trailer



Risk of injury when the automatic closing device is triggered

Never put your hand into the coupling jaw when the towbar coupling is open.

This prevents the coupling from closing automatically, and the coupling bolt causing serious injury to your hand.

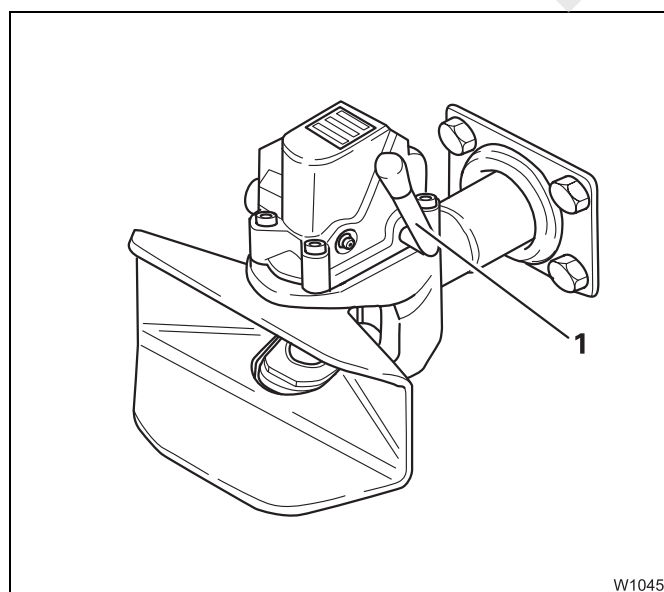

- Secure the trailer with the service brake and chocks as prescribed to prevent it from rolling away.
- Open the towbar coupling. Push the lever (1) up until it latches into place.
- Drive the truck crane carefully away from the trailer.



Risk of injury when closing the towbar coupling by hand

When closing, the lever moves down with great force in the direction of the coupling jaw. Therefore start the closing process only by moving the lever briefly in the direction of the coupling jaw with the hand balls. If you hold the lever and move it down, it may carry your hand with it and crush it.

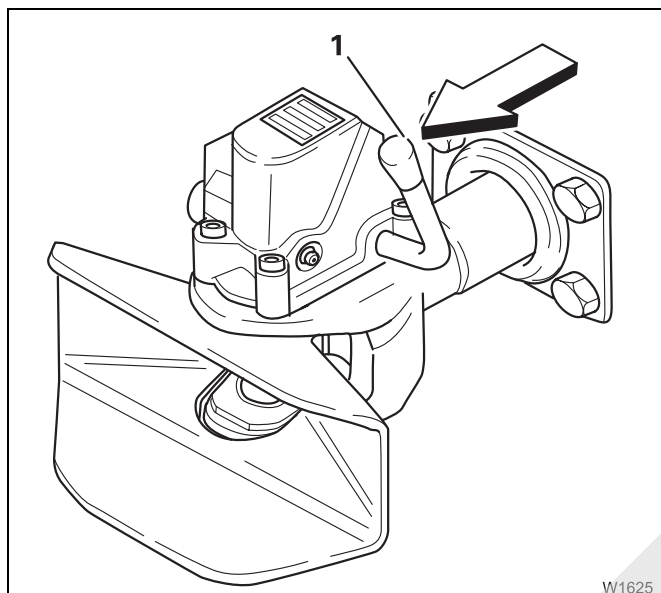

If no trailer is connected, you must close the towbar coupling by hand. Proceed as follows:

- Move the lever (1) briefly in the direction of the coupling jaw (observe the arrow).

The lever swings downwards and the towbar coupling is closed.



Risk of injury when the automatic closing device is triggered

Always close the coupling if no trailer is connected. This prevents people from being injured by the automatic closing device being activated unintentionally.



Checking the braking force

When a trailer is coupled and connected, you can check whether the braking force of the truck crane alone is sufficient for braking the truck crane and the trailer on uphill or downhill roads (e.g. when a brake hose has burst).

To check this, you can release the parking brake of the trailer on its own.

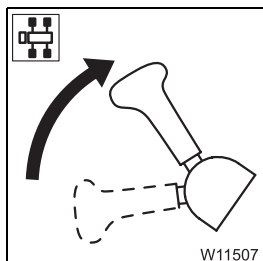

- Engage the parking brake

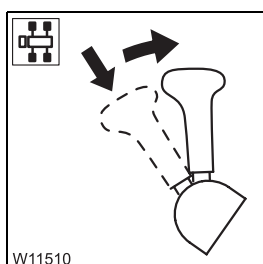

- Press the lever downwards and pull it further back.
As long as you hold the lever in this position, the parking brake on the trailer is released – the parking brake on the truck crane remains engaged.

In this way, you can check whether the braking force of the parking brake on the truck crane alone is sufficient to brake the truck crane and the trailer.

- Let go of the lever. The lever latches into position and the parking brake of the trailer is engaged.



Risk of accidents posed by truck crane moving unintentionally

When parking on downhill or uphill roads, always secure the truck crane and trailer against rolling away with wheel chocks in addition to the parking brake. Even when checking the parking brake has delivered a positive result. Observe the corresponding regulations in your country when doing this.

6 Driving modes

6.1	Driving modes	6 - 1
6.1.1	Information on how to use the tables	6 - 2
6.1.2	Table for a maximum axle load of 12 t (26500 lbs)	6 - 3
6.1.3	Maximum permitted speeds with an axle load of over 12 t (26 500 lbs)	6 - 6
6.2	Rigging work for driving with a trailer	6 - 7
6.2.1	Switching on the slewing gear freewheel	6 - 8
6.2.2	Switching on boom floating position	6 - 9
6.2.3	Switching on boom pre-tensioning	6 - 10
6.2.4	Switching the superstructure driving lights on / off	6 - 12

41005067

41005067

6

Driving modes

This chapter contains tables with driving modes of the GMK 4100, for which the maximum axle load is 12 t (26500 lbs).

6.1 Driving modes

Information on the axle loads

The GMK 4100 truck crane is designed for driving with maximum axle loads of 12 t (26500 lbs). **Manitowoc Crane Group Germany GmbH** points out that if the truck crane is driven with axle loads greater than 12 t (26500 lbs), the brake system may overheat and the braking deceleration will no longer be ensured.

If country-specific regulations allow driving with axle loads greater than 12 t (26500 lbs), the crane driver / crane operator bears sole responsibility for driving in this condition and for any damage which may result. This also applies to damage due to premature wear.



Risk of accidents due to increased braking distance

When driving with axle loads in excess of 12 t (26500 lbs), the braking deceleration required by the EU partial type-approval cannot be met. Please bear in mind that the braking distance of the truck crane will increase as a result.



Risk of damage due to premature wear

Premature wear of parts under particular strain (brake system, steering, tyres, wheels, suspension, drive shafts) cannot be ruled out even if the axle loads only briefly exceed 12 t (26500 lbs).



6.1.1

Information on how to use the tables

The tables consist of two parts:

- The driving mode of your truck crane is specified in the top part, next to **Equipment**. Find out which driving mode applies to your truck crane. Each truck crane has one driving mode only.
- The required rigging mode for this driving mode and the accessories which you are allowed to transport are specified in the middle section, next to **Rigging mode**.

Example of how to use the table:

Assume that your truck crane is equipped with 14.00 R25 tyres, 8 x 8 x 8 drive and eddy current retarder. In addition, the auxiliary hoist or the 0.6 t section is mounted.

In this case the driving mode in the upper part, next to equipment is **1**.

According to the specifications in the middle part, in addition to Rigging mode,

- the 3-sheave hook block may be attached to the front bumper,
- the 17 m (56 ft) lattice extension may be folded to the side and
- 6.3 t counterweights may be installed on the turntable.

Additional parts must be transported on an accompanying vehicle.

6.1.2

Table for a maximum axle load of 12 t (26500 lbs)

**For 14.00 R25
tyres**

Also observe the effects on the axle loads when towing a trailer;
▣▣▣▣ p. 5 - 85.

		Driving mode				
		1	2	3	4	5
Equipment	14.00 R25 tyres	✓	✓	✓	✓	✓
	8 x 6 x 8 drive				✓	✓
	8 x 8 x 8 drive	✓	✓	✓		
	Eddy current retarder	✓			✓	
	Auxiliary hoist or 0.6 t section installed	✓	✓	✓	✓	✓
Rigging mode	14.00 R25 spare wheel on rear of carrier		●		●	
	3-sheave hook block attached to the bumper ¹⁾	●	●	●	●	●
	17 m (56 ft) lattice extension folded to the side	●	●		●	
	6.3 t counterweight attached to the turntable	●	●	●	●	●
	2.2 t base plate on the counterweight platform			●		●

¹⁾ The weight of the hook blocks is based on the information in this operating manual; ▣▣▣▣ p. 16 - 2.

**For 16.00 R25
tyres**

Also observe the effects on the axle loads when towing a trailer;
▣▣▣▣ p. 5 - 85.

		Driving mode					
		1	2	3	4	5	6
Equipment	16.00 R25 tyres	✓	✓	✓	✓	✓	✓
	8 x 6 x 8 drive	✓		✓	✓		✓
	8 x 8 x 8 drive		✓			✓	
	Eddy current retarder			✓		✓	
	Auxiliary hoist or 0.6 t section installed	✓	✓	✓	✓	✓	✓
Rigging mode	16.00 R25 spare wheel on rear of carrier						●
	3-sheave hook block attached to the bumper ¹⁾	●	●	●	●	●	●
	17 m (56 ft) lattice extension folded to the side	●	●	●		●	●
	6.3 t counterweight attached to the turntable	●	●	●	●	●	●
	2.2 t base plate on the counterweight platform				●		

¹⁾ The weight of the hook blocks is based on the information in this operating manual; ▣▣▣▣ p. 16 - 2.

For 20.5 R25 tyres Also observe the effects on the axle loads when towing a trailer;
 ■■■► p. 5 - 85.

		Driving mode				
		1	2	3	4	5
Equipment	20.5 R25 tyres	✓	✓	✓	✓	✓
	10 x 6 x 10 drive	✓	✓			
	10 x 8 x 10 drive			✓	✓	✓
	Towbar coupling		✓		✓	✓
	Eddy current retarder	✓	✓	✓	✓	✓
	Auxiliary hoist or 0.6 t weight installed				●	●
Rigging mode	20.5 R25 spare wheel on rear of carrier				●	
	1-sheave hook block attached to the bumper ¹⁾	●	●	●		●
	3-sheave hook block attached to the bumper ¹⁾				●	
	10 m (33 ft) lattice extension folded to the side	●	●	●		
	17 m (56 ft) lattice extension folded to the side	●	●	●		
	6.3 t counterweight attached to the turntable				●	●

¹⁾ The weight of the hook blocks is based on the information in this operating manual; ■■■► p. 16 - 2.

6.1.3

Maximum permitted speeds with an axle load of over 12 t (26 500 lbs)

Should your national regulations allow driving with axle loads of over 12 t (26 400 lbs), you may under no circumstances exceed the maximum permitted speed given here.



Risk of accidents due to overloading of the tyres

Never exceed the maximum permitted speed which is given for the current axle load and tyre size.

This prevents the rope tyres from becoming overloaded and rupturing.

The maximum permissible speed depends on the size of the tyres and the axle load. The following values only apply to the given tyre pressure, and are maximum values. Also note the information provided by the tyre manufacturer regarding the maximum permitted load duration.



Tyre size / tyre pressure in bar (psi)	Current axle load in t (lbs)	Maximum permissible speed in km/h (mph)
14.00 R 25 / 10 (145.0)	up to 13.5 (29 800)	58 (36)
	up to 14.5 (32 000)	45 (28)
	up to 15.5 (34 200)	32 (20)
	up to 16.5 (36 400)	22 (14)
16.00 R 25 / 9 (130.5) 20.5 R 25 / 7 (101.5)	up to 13.5 (29 800)	65 (40)
	up to 13.5 (29 800)	65 (40)
	up to 14.5 (32 000)	65 (40)
	up to 15.5 (34 200)	58 (36)

6.2**Rigging work for driving with a trailer**

To reduce the axle loads to the specifications which apply in the country of use, you can set the main boom onto a trailer (dolly) when driving.

For this purpose, the truck crane must be fitted with a slewing gear free-wheel, boom floating position and if necessary, with a boom pre-tensioning device.

Before driving with the trailer, you must:

- Switch on the slewing gear freewheel;  p. 6 - 8
- Switch on the boom floating position;  p. 6 - 9
- Switch on boom pre-tensioning, if necessary;  p. 6 - 10

41005067

6.2.1

Switching on the slewing gear freewheel

When the main boom is set down on a trailer, the superstructure must be able to slew when driving around corners. You must switch on the slewing gear freewheel for this purpose.

- If a houselock is fitted, switch it off; *Switching off the houselock*, p. 12 - 16.



Risk of accidents with the houselock switched on

Always switch off the houselock before setting down the main boom on the trailer. Otherwise the superstructure will be unable to slew when driving around corners.

- Place the boom on the trailer as described in section *Switching on boom floating position*, p. 6 - 9.

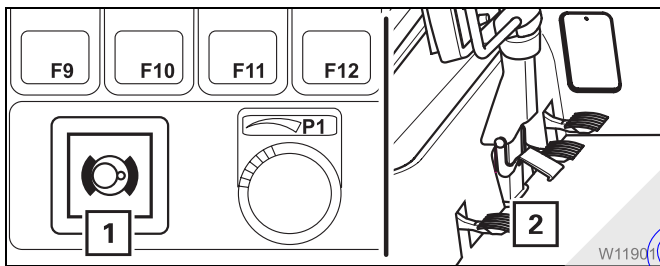

Prerequisites

- The engine for crane operation is running
- The slewing gear is switched on – the lamp (1) has gone out; p. 12 - 88.
- The pedal (2) is **not** actuated.

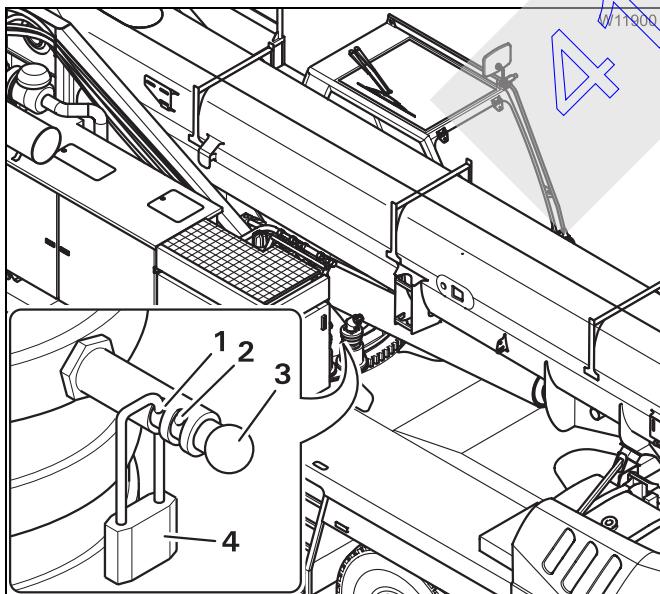

Switching on

- Remove the lock (4) from the bore (2).
- Push the pin (3) inward as far as it will go.
- Secure the pin with the lock in the bore (1) and remove the key.

Now the slewing gear freewheel is switched on and secured.

- Switch on the slewing gear freewheel on all slewing gears in the same way.



Switching off the slewing gear freewheel; p. 13 - 18.

6.2.2

Switching on boom floating position

If the main boom has been placed on a trailer, the boom floating position must be switched on so that the main boom can move up and down.



Risk of accidents when the boom floating position is switched off

Always switch on the boom floating position when the main boom is on a trailer.

This prevents the trailer hanging briefly with its full weight on the main boom on uneven ground, the axle loads from rising suddenly, or the truck crane from tipping when driving around corners.

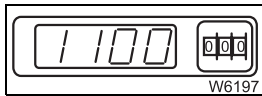

- Enter the SLI code for the current rigging mode.
- Fully retract the main boom.
- Raise the main boom to a permitted angle within the working range.
- Turn the superstructure to the 0° to the rear working position and place the main boom on a trailer.



Risk of accidents due to the main boom falling down

You may only switch on the boom floating position when the main boom is already set down on the trailer.

In this way, you prevent the raised main boom from falling down.

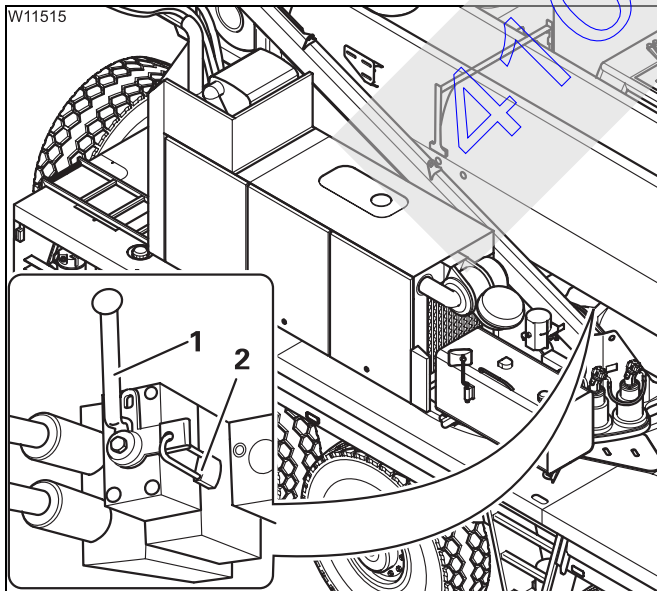

- Remove the padlock (2)
- Switch the valve I over – and position the lever (1) vertically, moving it either upwards or downwards depending on its fitting position
- Secure the lever (1) with the padlock (2)

The boom floating position is now switched on.



Switching off the boom floating position;  p. 13 - 17.

6.2.3

Switching on boom pre-tensioning

If the main boom has been set down on a trailer, you can change the axle loads on the rear axle lines by switching on the boom pre-tensioning.

To switch on the boom pre-tensioning, you must bring the valves I to IV into the required positions, and fill the pressure accumulator.

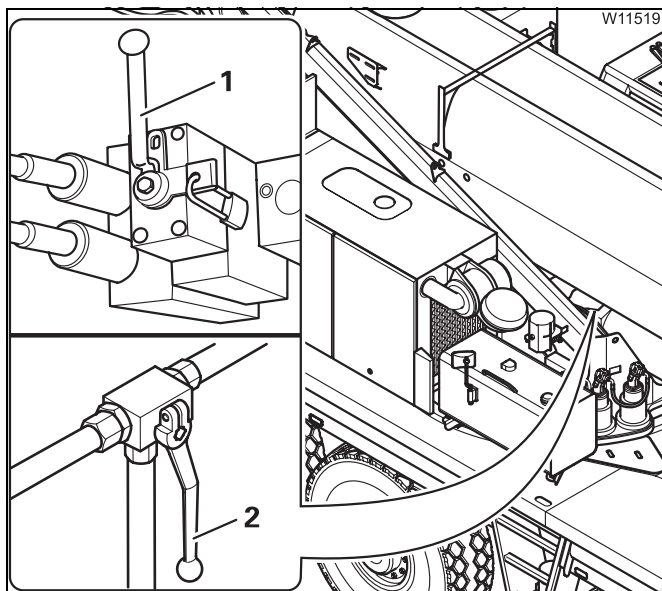

The valve I (1) is in the correct position if the boom floating position is switched on;
 ■■■► p. 6 - 9.

- Switch the valve IV over – lever (2) points downwards

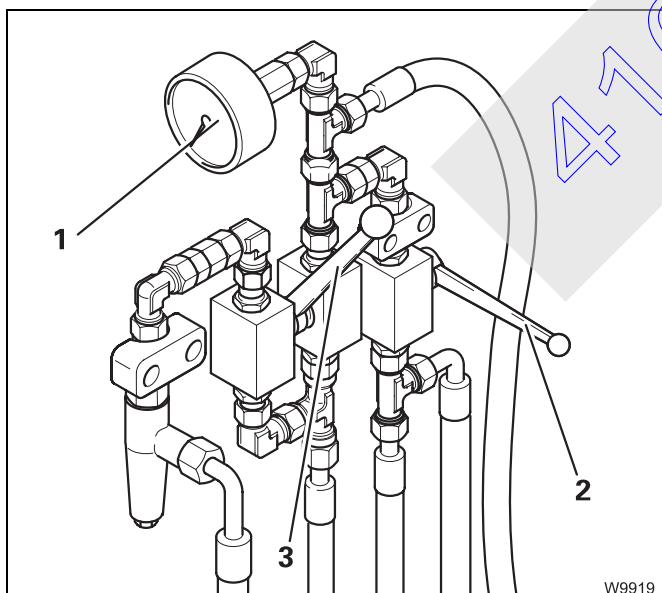

The valves II and III are under the pressure gauge (1).

- Close the valve II – the lever (2) is horizontal
- Open the valve III – the lever (3) points upward

You can now fill the pressure accumulator.

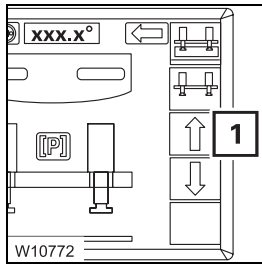

- Open the counterweight  submenu.
- Press the button (1) – *retract lifting cylinders*.
The pressure accumulator is filled.

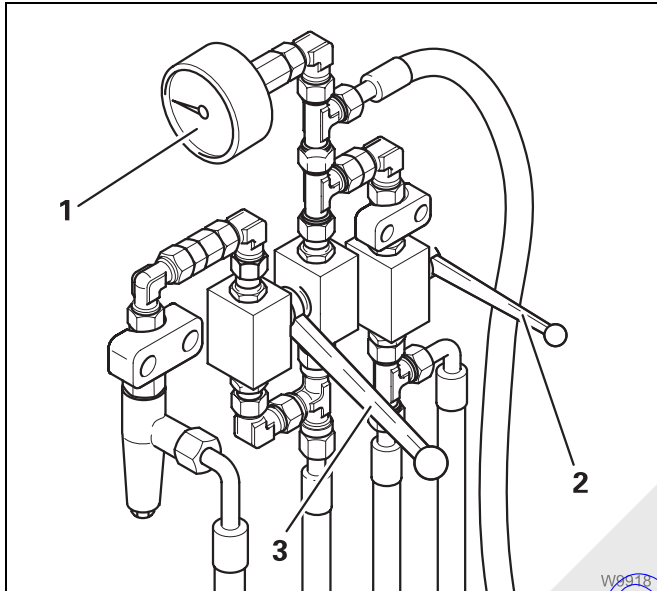

- Fill up the pressure accumulator until the pressure stops rising on the pressure gauge (1).
- Close the valve III – lever (3) points down.
The valve II stays closed – lever (2) is horizontal.
Now the boom pre-tensioning is switched on.



Switching off the boom pre-tensioning;  p. 13 - 19.

6.2.4

Switching the superstructure driving lights on / off

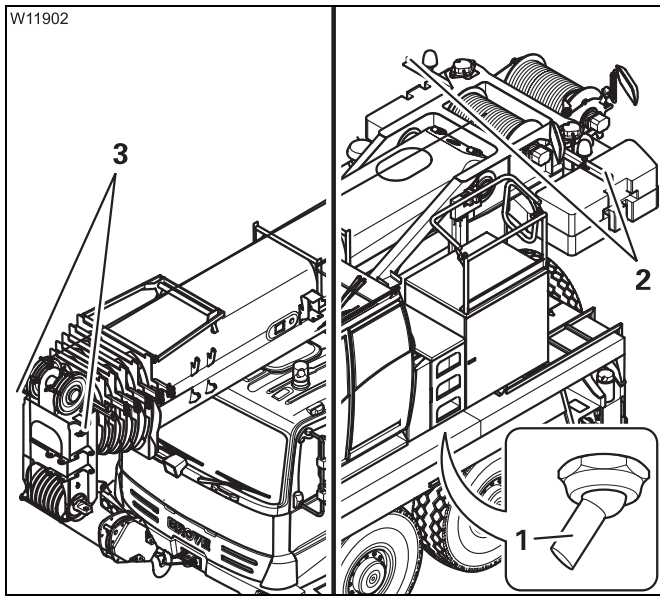

The lighting for the *superstructure* includes lamps (2) and (3).

With standard equipment, lamps (2) and (3) are always switched on or off together with the parking light and the headlights.

With additional equipment consisting of the switch (1), lamps (2) and (3) can be switched on or off separately when the parking light or headlights are switched on.

Switching off

When the boom is set down on a trailer, you can switch off the *Superstructure* driving lights when necessary, e.g. in order to conform to country-specific regulations for the colour of front and rear lights.

- Push the switch (1) to the right – outwards.

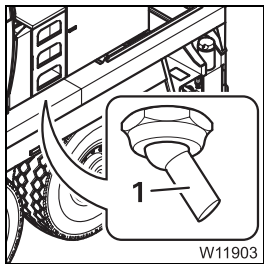

Switching on

When the main boom is in the boom rest, the *Superstructure* driving lights must be switched on.

- Push the switch (1) to the left – towards the turntable.

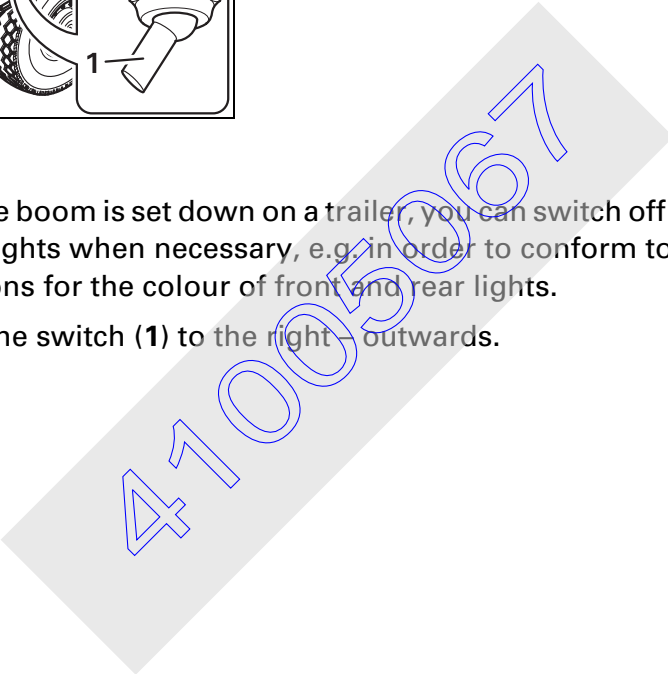
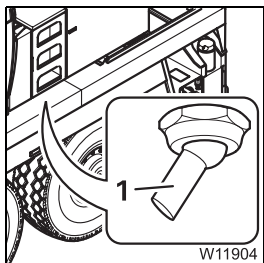

7 Malfunctions in driving mode

7.1	Emergency stop switch.	7 - 1
7.2	What to do when a malfunction occurs in road traffic	7 - 3
7.3	Towing the truck crane.	7 - 5
7.3.1	Towing in the event of engine or transmission damage.....	7 - 6
7.3.2	Starting to tow	7 - 10
7.4	Wheels and tyres	7 - 11
7.4.1	Wheel change	7 - 11
7.4.2	Filling the tyres yourself.....	7 - 15
7.5	Fuses	7 - 17
7.5.1	Fuses in the driver's cab.....	7 - 18
7.5.2	Fuses in the battery box.....	7 - 22
7.6	Finding and eliminating malfunctions.	7 - 23
7.6.1	Malfunctions on the engine	7 - 23
7.6.2	Malfunctions on the transmission.....	7 - 25
7.6.3	Service brake malfunctions	7 - 26
7.6.4	Steering malfunctions	7 - 27
7.6.5	Transfer case malfunctions	7 - 27
7.6.6	Malfunctions in the differential locks	7 - 28
7.6.7	Malfunctions in the hydraulic system / hydraulic oil cooler	7 - 28
7.6.8	Malfunctions on the suspension	7 - 29
7.6.9	Malfunctions on the level adjustment system	7 - 29
7.6.10	Malfunctions on the ECOS carrier.....	7 - 30
7.7	Procedure in the event of malfunctions	7 - 35
7.7.1	Switching on emergency operation in coolant circuit.....	7 - 35
7.7.2	Procedure in the event of malfunctions to the transmission and engine	7 - 36

41005067

7 Malfunctions in driving mode

7.1 Emergency stop switch

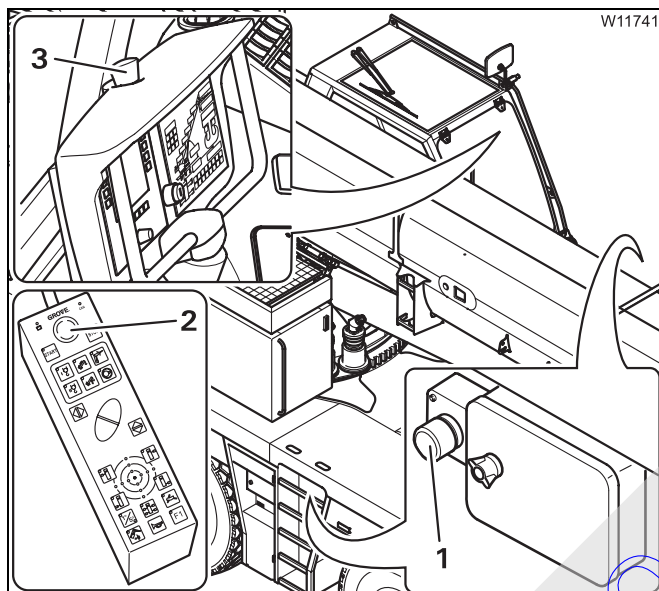

Four emergency stop switches are provided for an emergency:

- 1 On the carrier
- 2 On the hand-held control
- 3 In the crane cab

- Press one of the emergency switches (1), (2) or (3). The switch engages.

The engine goes out. If the engine for crane operation has previously been started, it is also shut down.

After activating an emergency stop switch;
➔ *Resetting the emergency stop switch, p. 4 - 22.*



The battery master switch cannot be used as an emergency stop switch for the engine. The engine continues to run after the battery master switch has been switched off.

Blank page

41005067

7.2**What to do when a malfunction occurs in road traffic**

If the truck crane can no longer be driven due to an accident or another malfunction, observe the following:

- Keep calm
- Brake the truck crane Observe the motorists and cyclists behind you
- Stop at a place which is safe for you and for the traffic behind you

**Risk of accidents due to poor visibility**

If possible, do not stop in a tunnel or directly behind a curve.

- Secure the truck crane in compliance with the legal regulations which currently apply in the country where you are working.

**Risk of accidents during repair work in danger areas**

Even simple repairs can be dangerous in danger areas (e.g. tunnels, crossroads, motorway bridges).

In danger areas, only carry out the repair work required to leave the danger area.

If you are unable to rectify the damage yourself, contact **CraneCARE** or have the crane towed away;  *Towing the truck crane*, p. 7 - 5.

Blank page

41005067

7.3

Towing the truck crane

Observe the following when towing the truck crane:

- The truck crane may only be towed away with a tow bar. Attach the tow-bar to the tow-rod coupling on the front bumper.
- The statutory regulations in the country of use concerning the overall length of the towing and towed vehicle, including the towing bar, must be observed.
- If the engine, the steering and the service brake still work, you can tow the truck crane with a lorry.
- If the engine, the steering or the service brake no longer function properly, the truck crane must be towed with a special breakdown truck.

The front towing coupling is designed for a maximum tractive force of 10 t (22 000 lbs). The tractive force may only be applied forwards or at an angle of 45° to both sides from the longitudinal axle of the truck crane.

41005067

7.3.1

Towing in the event of engine or transmission damage

The following information only applies to towing the truck crane out of the immediate danger area in the event of damage to the engine or transmission.



Risk of accidents and damage when towing the truck crane long distances

Tow the truck crane at a maximum speed of 10 km/h (6 mph) and over a distance of max. 1 km (0.62 mi). Additional measures must be taken for longer distances. In these cases, contact **CraneCARE**.

Compressed-air supply

When the engine fails, the truck crane must be supplied with compressed air by the towing vehicle so that the brake system is still supplied with compressed air.

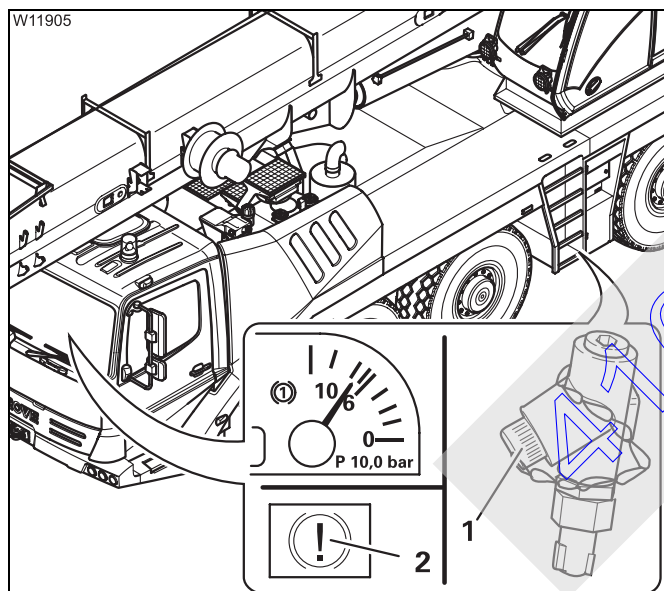

- Connect the filler connection (1) with the *Supply* coupling head of the towing vehicle.

When towing, the following must be available in the driver's cab:

- A supply pressure of at least 6 bar (87 psi) must be displayed
- The lamp (2) must have gone out

Electric power supply

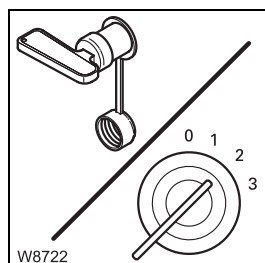

- Switch on the battery master switch.
- Turn on the ignition.

On the transmis- sion

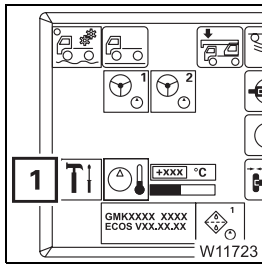

- Select neutral on the transmission; p. 5 - 30.
- If necessary, open the main menu and press the button (1).

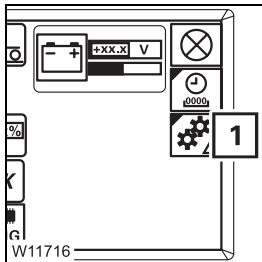

The *Settings* submenu opens.

- Press the button (1) once.

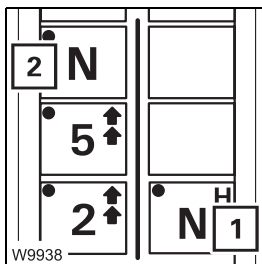

The *Transmission emergency program* submenu opens.

- Additionally, press the button (2) once and observe the colour of the symbol (1):
 - **Grey:** towing is permitted only at lowest speed and to remove the truck crane from the immediate danger area
 - **Black:** you can switch on towing mode

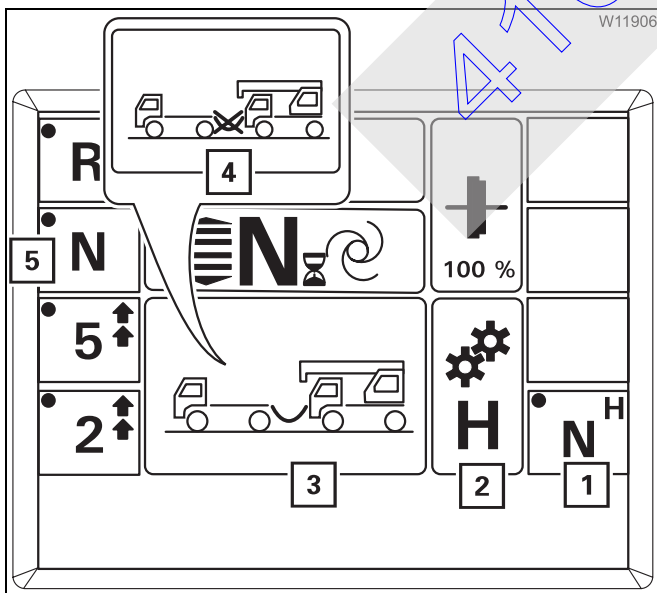

Switching on towing mode

- Press the button (1) once.
The symbol (3) appears and the display (2) shows the entry **H**.

Towing mode is switched on.

Switching off towing mode

- Press the button (5) once.
The symbol (4) appears and the display (2) shows the entry **L**.

Towing mode is switched off.



If the symbol (3) is displayed, the towing mode is switched on. Even if the display (2) indicates neither **H** nor **L** due to a malfunction.



Axle drives

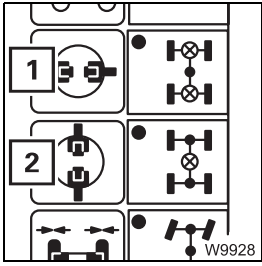

- Switch off all differential locks.

The **green** symbols (1) and (2) must be shown; *Switching off*, p. 5 - 64

Transfer case

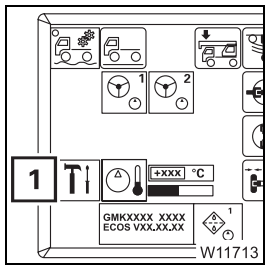

Prior to being towed away, you must switch the transfer case into the neutral position.

- If required, open the main menu .
- Press the button (1) once.
The *Settings* submenu opens.

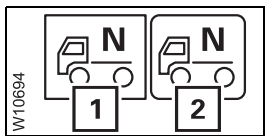

- Press the button (1) once.

The neutral position is switched on when the symbol (2) is shown.



To switch off the neutral position, you must switch the off-road gear on or off in the main menu; p. 5 - 62.

Parking brake

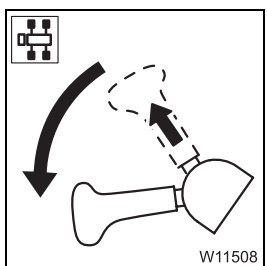

- Release the parking brake.
The lamp must go out.

If the lamp continues to light up, the supply pressure may be too low. Let the engine of the truck crane or towing vehicle run depending on the compressed-air supply, until the supply pressure has been built up; *Building up supply pressure*, p. 5 - 9.

If the lamp fails to go out, damage has occurred to the parking brake, and you should contact **CraneCARE**.



Risk of accidents in the event of faulty brakes

If damage has occurred to the service brake system, you may only tow the truck crane away from the immediate danger area after receiving permission to do so from **CraneCARE**.

Towing the truck crane out of the danger area

If you have made all the adjustments in the way described in this section, you can tow the truck crane away from the danger area.

- Ensure that the tractor-vehicle only drives off slowly.

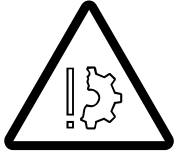

Risk of damage to the chassis

Starting to tow too quickly or in jolts can damage the chassis.

- Remember that the steering is sluggish.
If the engine fails, only the emergency steering pump will be available, which only supports the steering from a speed of at least 2 km/h (1.2 mph).



Risk of accidents due to sluggish steering

At speeds of less than 2 km/h (1.2 mph), the truck crane can hardly be steered.

- Tow the truck crane at a **maximum of 10 km/h (6 mph)**.
- Ensure that the towing distance is a maximum of **1 km (0.62 mi)**.

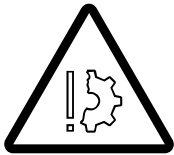

Risk of accidents and damage when towing the truck crane long distances

Tow the truck crane at a maximum speed of 10 km/h (6 mph) and over a distance of max. 1 km (0.62 mi). Additional measures must be taken for longer distances. In these cases, contact **CraneCARE**.

7.3.2

Starting to tow

You can also start the engine by starting to tow.

- Turn on the ignition.

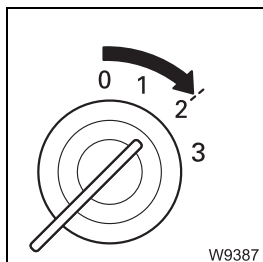

- Select an appropriate starting gear (third or fourth gear possible).
The selected gear must be displayed.

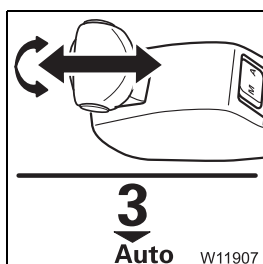

- Start to slowly tow the truck crane at a speed of maximum 20 km/h (12 mph).



Risk of damage to the engine

A warning buzzer sounds if the maximum permissible speed is exceeded. Do not press the accelerator as long as the warning buzzer sounds. Reduce the towing speed until the warning buzzer stops buzzing.

- Kick down the accelerator once the speed is high enough to start the engine.

The transmission engages automatically.

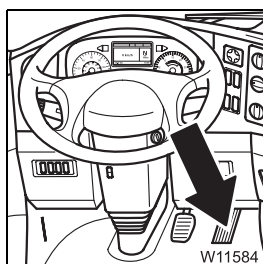

7.4

Wheels and tyres

This section contains all the information about changing a wheel and about the use of the tyre inflator connection.

7.4.1

Wheel change

- If a puncture occurs while driving, stop the truck crane, taking the following traffic into account, and secure in the way described in the legal regulations stipulated in the country of use.
- Select an even place, if possible, to change the tyres.



Risk of accidents due to an overturning wheel

If you lean a wheel against the truck crane briefly when changing a wheel, secure it against falling over with a rope. Only move the outriggers if no wheel is leaning against the truck crane.

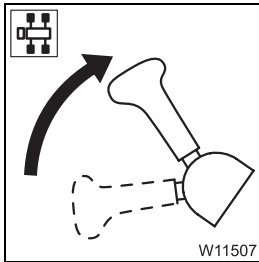

- Engage the parking brake

41005067



Removing a damaged wheel

- Switch off the suspension; ▮▮▮▮▶ p. 5 - 15.
- Raise the truck crane with the outriggers until the wheel that is to be changed only just leaves the ground.



Risk of accidents due to an overturning wheel

When unscrewing the last wheel nuts, the wheel can slip off the hub and fall in your direction. Secure the wheel and step back quickly if the wheel threatens to tip.

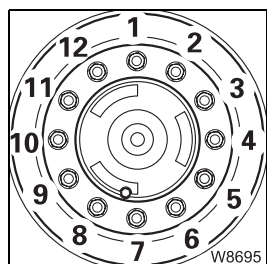

- Remove the wheel nuts (1) to (12) and remove the damaged wheel.
- Secure the wheel against toppling over if you set it down temporarily.

On the spare wheel holder

When changing a wheel, you must remove the spare wheel from the spare wheel holder and mount the damaged wheel onto the spare wheel holder. To lift the wheel, use a chain hoist or the truck crane.

- If you lift the wheel with the truck crane,
 - Support the truck crane and
 - Enter the current rigging mode on the SLI.



Danger of overturning if the truck crane is free on wheels

Always support the truck crane on outriggers before rotating the superstructure.

Never operate the truck crane in the *Free on wheels* working position if the tyres are damaged.



Risk of overturning while slewing

Always check before slewing whether slewing is permitted in the truck crane's current rigging mode (counterweight, outrigger span, working radius).

Correct the rigging mode if necessary; ▮▮▮▮▶ *Slewing with rigged counterweight*, p. 13 - 82.

- Lift the spare wheel using only lifting gear with sufficient load bearing capacity; ▮▮▮▮▶ *Spare wheel*, p. 8 - 4.

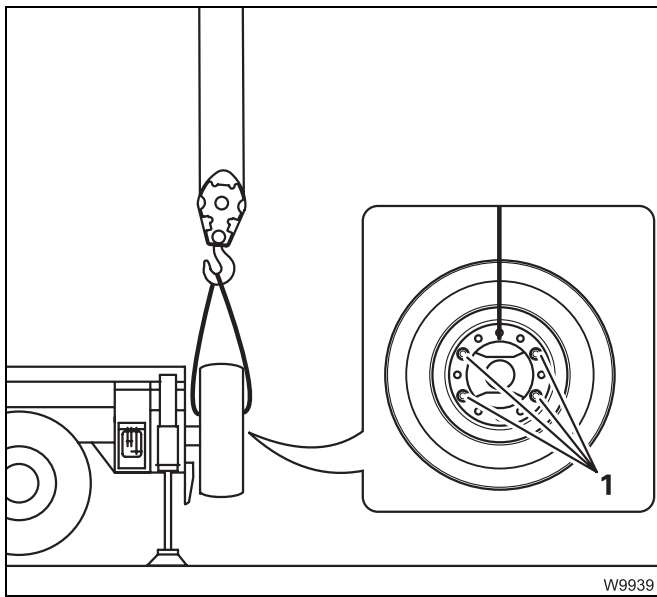

Removing a wheel

- Undo the nuts (1).
- Raise the spare wheel from the spare wheel holder.
- Secure the spare wheel against falling over when you put it down temporarily.

Mounting a wheel

- Lift the wheel onto the spare wheel holder.
- Fit the wheel with the nuts (1), and tighten the nuts with 500 Nm (370 lbf ft).

Mounting a wheel

- Check whether the bearing surfaces of the wheel rim and hub are clean (no paint, grease or oil).
- Grease the wheel studs slightly.



Risk of accidents

Check the wheel rim, the tyres, the wheel nuts and the wheel studs for damage before mounting the spare wheel.

Damaged parts must not be mounted.

Mount only the original wheel as listed in the spare parts list or a permitted wheel of the same size and load bearing capacity.

- Put the wheel on the hub in an upright position.
- Extend or retract the outrigger cylinders until the holes in the wheel rims are in line with the wheel studs.
- Push the wheel onto the wheel studs. Make sure the thread of the wheel studs is not damaged.



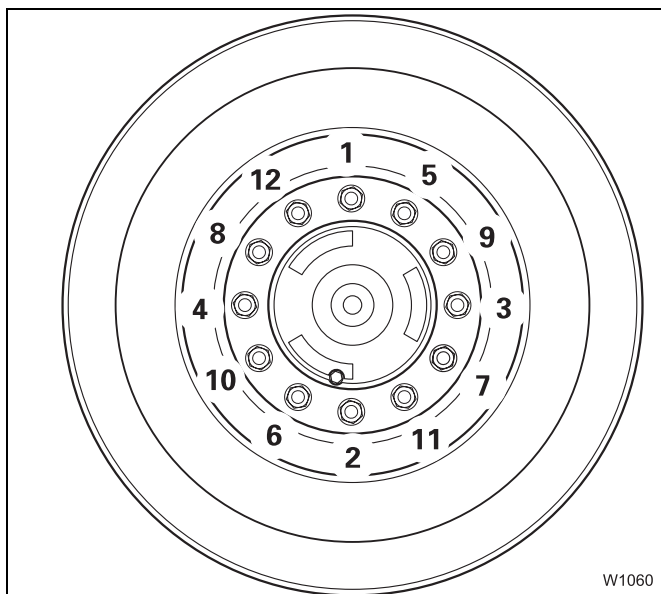

- Turn the wheel nuts (1) and (2) tight in order to secure the wheel.
- Turn the remaining the wheel nuts tight.
- Always tighten the wheel nuts in the order (1) to (12)
 - First all wheel nuts with 200 Nm (150 lbf ft)
 - Then all wheel nuts with 400 Nm (300 lbf ft)
 - Finally, all wheel nuts with 650 Nm (480 lbf ft)

Tighten all wheel nuts after 50 km (30 mi) and 150 km (90 mi) again with 650 Nm (480 lbf ft).

41005067

7.4.2

Filling the tyres yourself

In emergencies you can fill the tyres with the compressed air system of the truck crane if an appropriate filling hose is available.

The tyres can be filled up to a maximum pressure of about 8 bar (116 psi).

This pressure might not correspond to the prescribed tyre pressure, depending on the tyres;  *Tyres*, p. 8 - 5.



Risk of accidents due to impermissible tyre pressure

If the maximum pressure is above the specified tyre pressure, fill the tyres up to the maximum specified pressure.

In this way you prevent the tyres from becoming damaged during driving, and bursting.

Always drive directly to a service station or garage and adjust the tyre pressure as soon as you have filled the tyres yourself.

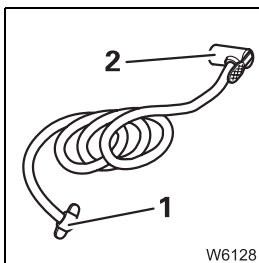

The filling hose has a tyre inflator connection (2) and a connection (1).

Connecting the filling hose

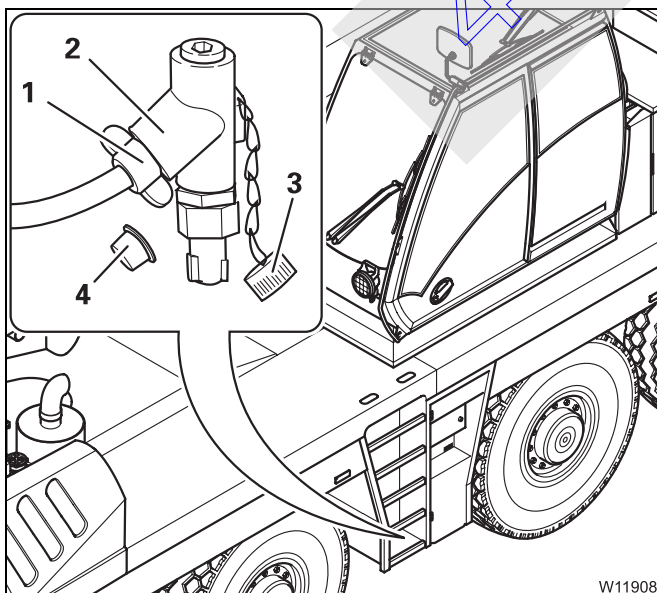

- Remove the caps (3) and (4).
- Fasten the connection (1) to the filler connection (2).

You can now fill the tyres.



Filling the tyres

The maximum operation pressure of the compressed air system of 8 bar (116 psi) can only be reached with the engine running.

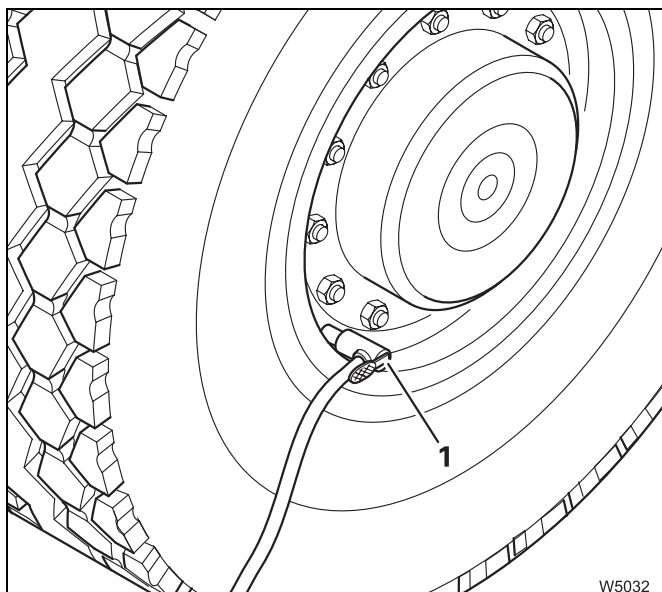

- Start the engine; ►► p. 4 - 13.
- Fasten the tyre connection (1) to the tyre valve
- Actuate the button on the tyre connection and fill the tyre
- Disconnect the tyre connection (1) from the tyre valve

Removing the filling hose

Before driving, you must remove the filling hose from the filler connection.

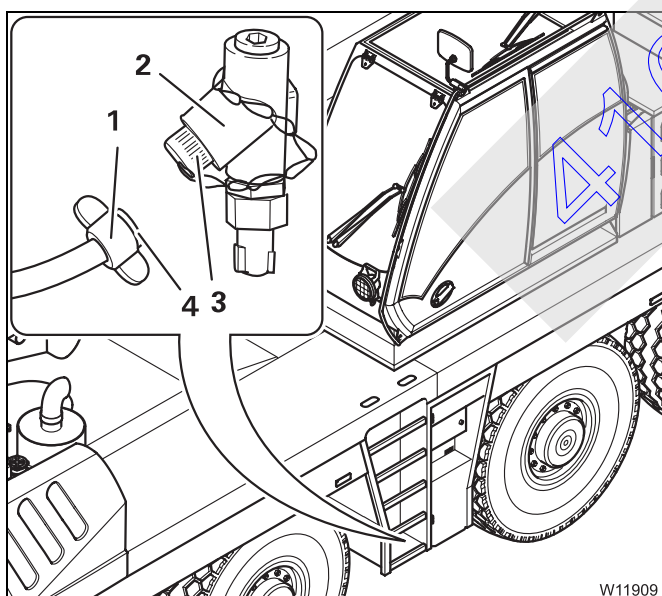

- Remove the connection (1) from the filler connection (2)
- Close the filler connection and the connection with the caps (3) and (4)
- Stow the filling hose away
- Drive to a service station or workshop and adjust the tyre pressure



Risk of damage to the compressed air system

Always close the filler connection with the cap.

This prevents damage and contamination occurring in the compressed air system.

7.5

Fuses

The fuses are divided into groups and are at various points of the carrier:

- In the driver's cab
- In the battery box

Notes on changing fuses

The positions of the fuses, their designations and which functions are protected by the respective fuses are shown in the following sections.

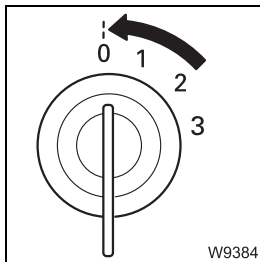

- Switch off the ignition whenever a fuse has to be replaced.



Risk of damage when the ignition is switched on

Switch off the ignition whenever a fuse has to be replaced. In this way you can prevent the new fuse from being damaged by the increased starting current immediately after inserting it.



Risk of damage due to overloading

Replace blown fuses only with new fuses of the same amperage. In this way you can prevent parts from being overloaded and damaged or the fuse from being immediately damaged again.

Notify **CraneCARE** if a fuse of the same amperage blows again after turning on the ignition.



Danger of fire

Never repair a blown fuse with other electrically conductive materials.

7.5.1

Fuses in the driver's cab

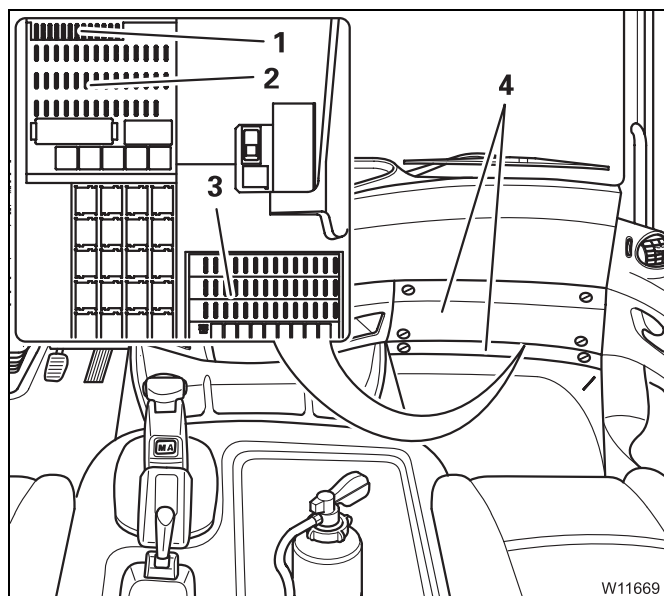

- Remove the covers (4).

- 1 Reserve fuses
- 2 Fuses F1 to F 41
- 3 Fuse groups A1, A2

The following sections show the designations of the individual fuses, including their amperage and functions.

F1 to F 41

The fuses are labelled with the numbers.

- Observe the instructions regarding fuse changes; ► p. 7 - 17.

Designation	Amperage (A)	Function
F1	10	Fog tail light
F2	10	Instrument lighting
F3	–	Free
F4	10	Radio 24 V
F5	–	Free
F6	–	Free
F7	15	Distribution terminal D+
F8	10	Mirror heating
F9	15	Socket 24 V
F10	10	Tachograph, Engine / transmission diagnostics
F11	20	Trailer socket
F12	20	Trailer socket, trailer ABS
F13	10	Cab lighting
F14	–	Free
F15	10	Transmission
F16	–	Free
F17	20	Heater fan, air-conditioning system

Designation	Amperage (A)	Function
F18	10	Radio, wireless, telephone, heating
F19	10	Socket 24 V
F20	15	Window winder, passenger door
F21	15	Window winder, driver's door, mirror adjustment / mirror heating operation
F22	10	Turn signal indicator Windshield wiper washer system
F23	10	Headlight, right
F24	10	Headlight, left
F25	10	Right full-beam headlight
F26	10	Left full-beam headlight, check full-beam headlight
F27	10	Everything, left: Tail lights, parking light Side marker lights Trailer lighting
F28	10	Everything, right: Tail lights, parking light Side marker lights Lighting
F29	10	Electronic gear system
F30	15	Engine electronics
F31	10	Mirror adjustment
F32	–	Free
F33	10	Turn signal indicator Windshield wiper washer system
F34	10	Brake lights, reversing lights, trailer socket
F35	10	ABS trailer
F36	–	Free
F37	10	Windscreen washing system
F38	10	Tachograph
F39	10	Horn Engine / transmission diagnostics plug
F40	–	Free
F41	10	Seat heating



A1 to A3

- Observe the instructions regarding fuse changes;  p. 7 - 17.

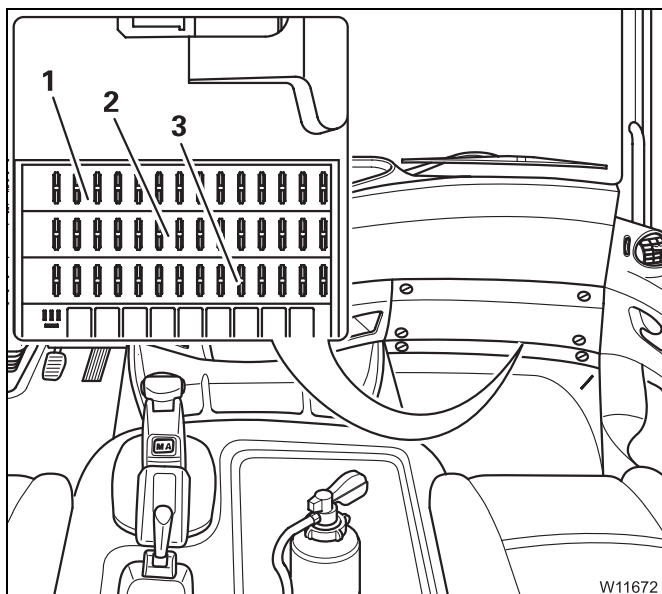

The fuse groups are labelled.

- 1 A1 – here called A1
- 2 A1 – here called A3
- 3 A2

In each group, the fuses are labelled as F1 to F14.

A1 Designation	Amperage (A)	Function
F1	10	Auxiliary heater time switch
F2	20	Auxiliary heater
F3	–	Free
F4	–	Free
F5	10	Socket 24 V
F6	15	24 V / 12 V voltage transformer
F7	–	Free
F8	10	Rotating beacon
F9	–	Free
F10	15	Display, driver's cab
F11	–	Free
F12	–	Free
F13	15	Gearbox control
F14	–	Free

A2 Designation	Amper- age (A)	Function
F1	5	Air intake inhibitor
F2	–	Free
F3	10	ESX3 control unit
F4	10	Hand-held control
F5 to F14	–	Free

A3 Designation	Amper- age (A)	Function
F1	20	Eddy current retarder
F2	5	Outrigger lighting ECOS control unit
F3	10	ESX3 control unit
F4	10	Steering lock query (for driving from the superstructure)
F5	10	Vehicle height monitor 
F6	–	Free
F7	15	Oil cooler
F8	10	Central lubrication
F9	10	Fuel pump
F10	10	ECOS control unit
F11	11	Steering
F12	5	Engine emergency stop switch, Air intake inhibitor
F13	20	Voltage supply CAN bus
F14	20	ESX3 control unit, Voltage supply for I/O circuit boards

7.5.2

Fuses in the battery box

Fuses F6 to F7 are contained in the battery box.



Danger due to lead and lead compounds of batteries

Battery poles, battery terminals and parts of the battery itself contain lead and lead compounds. Wash your hands after working on these parts or in these areas.

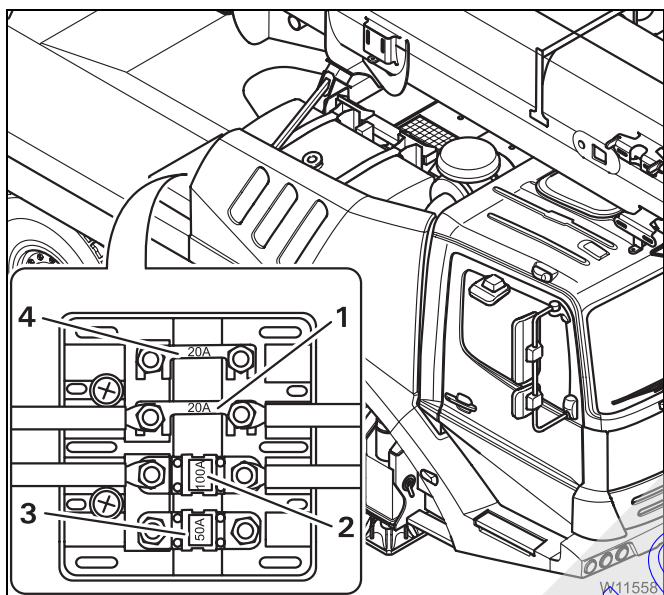

- Open the battery box.

The fuses are in a terminal box on the right side next to the batteries.

- Remove the lid from the terminal box:

- 1 Fuse F6
- 2 Fuse F7
- 3 Free
- 4 Free

- Observe the instructions regarding fuse changes; → p. 7 - 17.

Designation	Amperage (A)	Function
F6	20	Preliminary fuse for auxiliary heater switch timer, tachograph and radio
F7	100	Carrier central fuse

7.6

Finding and eliminating malfunctions

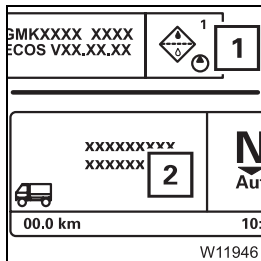

This section does not include all malfunctions.

- If a warning is shown in the display (1); p. 5 - 48.
- If a warning is shown on the display (2); p. 5 - 50.

7.6.1

Malfunctions on the engine



In addition to this information; *Separate engine operating instructions, provided by the manufacturer.*

Malfunction	Cause	Remedy
Engine will not start – Starter does not turn	Battery master switch is switched off	Switch on the battery master switch; p. 4 - 8
	Ignition off	<i>Switching on the ignition, p. 4 - 9</i>
	Transmission not in neutral position	<i>Switching the transmission to neutral position, p. 5 - 30</i>
	Parking brake released	Lock the parking brake; p. 3 - 44
	Fuse F30 blown	Replace blown fuses; p. 7 - 18
	Bridging plug for the hand-held control not inserted	Insert bridging plug; p. 13 - 20
	Emergency stop switch actuated	Release the emergency stop switch; p. 4 - 22
The truck crane drives at a maximum of 20 km/h (12 mph)	A locking procedure is not yet completed	Lock the differential locks or steering
	Off-road gear on	Switch off the off-road gear; p. 5 - 62











Malfunction	Cause	Remedy
Engine will not start - Starter turns	Batteries insufficiently charged	Charge the batteries; ▣▣▣▣➔ <i>Maintenance manual</i>
	Fuel tank empty	1. Refuelling; ▣▣▣▣➔ p. 4 - 7 2. Bleed the fuel system; ▣▣▣▣➔ <i>Maintenance manual</i> ▣▣▣▣➔ <i>Separate engine operating instructions, provided by the manufacturer</i>
	Air intake inhibitor closed	▣▣▣▣➔ <i>Releasing the air intake inhibitor, p. 4 - 23</i>
	Fuse F9 blown	Replace blown fuses; ▣▣▣▣➔ p. 7 - 18
Coolant temperature too high	Coolant level too low	Top up coolant; ▣▣▣▣➔ <i>Maintenance manual</i>
	Oil level in the transmission too low	Check the oil level; ▣▣▣▣➔ <i>Maintenance manual.</i>
	Outside of heat exchanger dirty	Clean the heat exchanger
	V-belt of coolant pump at engine loose	Tension V-belt; ▣▣▣▣➔ <i>Separate engine operating instructions, provided by the manufacturer</i>
	The fan wheel on the engine does not turn	Switch the fan wheel to emergency operation; ▣▣▣▣➔ p. 7 - 35
Engine cannot be turned off with ignition key	Malfunction in the electronics	Turn off the engine with the emergency stop device; ▣▣▣▣➔ p. 7 - 1.
Motor brake (engine retarder) cannot be switched on	Fuse A3F1 defective	Replace blown fuses; ▣▣▣▣➔ p. 7 - 20
Engine / transmission diagnostics plug not working	Fuse F10, F39 defective	Replace blown fuses; ▣▣▣▣➔ p. 7 - 18
The capacity of the engine is reduced	Coolant too hot or other malfunction The engine is not switched off in order to drive on to the next place where it is possible to stop.	Coolant too hot: Wait until the coolant has cooled down – the power goes back up Other malfunction: CraneCARE must be notified

7.6.2

Malfunctions on the transmission

Malfunction	Cause	Remedy
Neutral position cannot be activated	Transmission switch lever or two-stop rocker not in home position	Switch the transmission switch lever and two-stop rocker to home position.
Transmission not shifting automatically	Operating mode <i>Manual</i> switched on	Change-over to <i>Automatic</i> ; ▶▶▶▶▶ p. 5 - 30
	Fuse F15, F29, A1F13 defective	Replace blown fuses; ▶▶▶▶▶ p. 7 - 17
Starting gear cannot be engaged	Supply pressure in secondary consumers too low	Build up supply pressure; ▶▶▶▶▶ p. 5 - 9
Transmission no longer upshifts at speeds over 20 km/h (12 mph)	A locking procedure is not yet completed	Lock the differential locks or steering
	Off-road gear on	Switch off the off-road gear; ▶▶▶▶▶ p. 5 - 62
Transmission does not respond to the transmission switch lever or the two-stop rocker	Fuse F15, A1F13 defective	Replace blown fuses; ▶▶▶▶▶ p. 7 - 17
	Electronic gear system is no longer connected to the transmission	Switch to <i>Transmission emergency program</i> ; ▶▶▶▶▶ p. 7 - 36
 Lights up	Transmission cannot downshift since the maximum permissible engine speed would otherwise be exceeded.	Slow down the truck crane until the symbol goes out
Engine / transmission diagnostics plug not working	Fuse F39, F10 defective	Replace blown fuses; ▶▶▶▶▶ p. 7 - 18
The transmission is not in neutral position after switching on the ignition.	The parking brake was released when the ignition was switched off	
	Mechanically switch the transmission to neutral position if the engine cannot be started because a gear has been selected and the air pressure is below 5.5 bar (80 psi); ▶▶▶▶▶ p. 7 - 41	

7.6.3 Service brake malfunctions

Malfunction		Cause	Remedy
	Lights up while driving or goes out after the engine is started	The air pressure in one of the two circuits has fallen below 5.5 bar (80 psi)	The vehicle can be driven slowly to the next garage.
		The air pressure in both circuits has fallen below 5.5 bar (80 psi)	<ol style="list-style-type: none"> 1. Top up the compressed-air supply on the filler connection;  p. 7 - 6 2. Tow the truck crane with the towing bar;  p. 7 - 6
 	Parking brake unable to be released - Does not go out - Off	Supply pressure is too low	 <i>Building up supply pressure,</i> p. 5 - 9
 	Also lights up at over 6 km/h (4 mph)	The trailer ABS brake system on the trailer has failed	Drive to next workshop; braking without ABS support is still possible.
The retarder cannot be switched off		Fuse A3F1 defective	Replace blown fuses;  p. 7 - 17





7.6.4 Steering malfunctions

Malfunction	Cause	Remedy
Steering wheel hard to turn, grating noises when steering	Oil level in the hydraulic oil tank too low	Check hydraulic oil level; <i>Maintenance manual</i> .
Symbol or red	Oil level in the hydraulic oil tank too low	Then drive at low speed to the nearest workshop and have the cause checked.
	Steering circuit has failed, e.g. pump faulty	The vehicle can be driven slowly to the next garage.
Symbol and red	Both steering circuits have failed	The truck crane cannot be driven any further, since it can no longer be steered.
Separate steering cannot be activated	Current speed over approx. 5 km/h (3 mph)	Slow down or stop the truck crane
Separate steering cannot be switched off	Current speed over approx. 5 km/h (3 mph)	
Separate steering not working	Fuse A2F3, A3F2, A3F3, A3F14 defective	Replace blown fuses; p. 7 - 20
Separate steering not working and the ECOS display shows an error message	ECOS malfunction	Read the error messages (p. 7 - 30) and inform CraneCARE

7.6.5 Transfer case malfunctions

Malfunction	Cause	Remedy
Switching operations are not conducted	Pressure of 5.5 bar (80 psi) has not yet built up in the reservoirs	Build up supply pressure; p. 5 - 9
	Fuse A2F3, A3F2, A3F10, A3F14 defective	Replace blown fuses; p. 7 - 20
Error symbol is displayed	ECOS malfunction	Read the error messages (p. 7 - 30) and inform CraneCARE

7.6.6 Malfunctions in the differential locks

Malfunction	Cause	Remedy
Differential locks cannot be switched on	Current speed over approx. 5 km/h (3 mph)	Slow down or stop the truck crane
	Drive line under tension	Slowly drive truck crane back and forth,  p. 5 - 63
	Compressed air system insufficiently filled	 <i>Building up supply pressure</i> , p. 5 - 9
	Fuses A2F3, A3F2, A3F10, A3F14 defective	Replace blown fuses;  p. 7 - 17
Differential locks cannot be switched off	Current speed over approx. 5 km/h (3 mph)	Slow down or stop the truck crane
	Drive line under tension	Slowly drive truck crane back and forth,  p. 5 - 63
Error symbol is displayed	ECOS malfunction	Read the error messages ( p. 7 - 30) and inform CraneCARE

7.6.7 Malfunctions in the hydraulic system / hydraulic oil cooler

Malfunction	Cause	Remedy
Hydraulic oil temperature above 80 °C, fan in the hydraulic oil cooler is running	Hydraulic system under extreme strain and ambient temperature very high	Stop the truck crane while taking the traffic situation into account and run the engine until the oil has cooled down.
Hydraulic oil temperature above 80 °C, fan in the hydraulic oil cooler is not running	Fuse A3F7 defective	Stop the truck crane while taking the traffic situation into account, and replace the blown fuse if necessary;  p. 7 - 17
	Defective temperature sensor in the hydraulic system (error message is displayed)	Have the temperature sensor replaced

7.6.8 Malfunctions on the suspension

Malfunction	Cause	Remedy
Suspension cannot be activated	Current speed over approx. 5 km/h (3 mph)	Slow down or stop the truck crane
	Compressed air system insufficiently filled	▣▣▣▣► <i>Building up supply pressure</i> , p. 5 - 9
Suspension cannot be switched on or off	Fuses A2F3, A3F2, A3F10, A3F14 defective	Replace blown fuses; ▣▣▣▣► p. 7 - 20
Error symbol is displayed	ECOS malfunction	Read the error messages (▣▣▣▣► p. 7 - 30) and inform CraneCARE

7.6.9 Malfunctions on the level adjustment system

Malfunction	Cause	Remedy
Level adjustment system not working	Suspension switched off	▣▣▣▣► <i>Switching on the suspension</i> , p. 5 - 15
	Fuses A2F3, A3F2, A3F10, A3F14 defective	Replace blown fuses; ▣▣▣▣► p. 7 - 20
Error symbol is displayed	ECOS malfunction	Read the error messages (▣▣▣▣► p. 7 - 30) and inform CraneCARE

7.6.10

Malfunctions on the ECOS carrier

This section contains general malfunctions, and malfunctions which generate an error display. It also contains information on reading error messages on the *Outrigger* control units.

ECOS program version

Always note down the number of the program version after a malfunction occurs before notifying **CraneCARE**.

- If required, open the main menu .

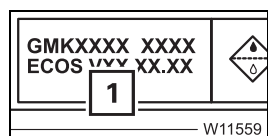

The display (1) shows the number of the current program version.

General malfunctions

The following table contains information on finding faults and possible remedial measures.

Malfunction	Cause	Remedy
Ignition on – ECOS display remains dark	Fuse A3F2, A3F10 defective.	Replace the blown fuse;  p. 7 - 20.



If further malfunctions occur, the corresponding error messages are shown in the *ECOS* display.

Error messages

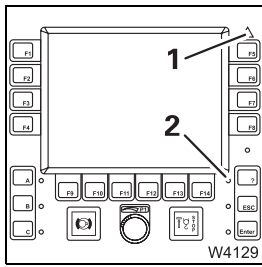

If ECOS detects an error, an error message is indicated:

- lamp (1) flashes and
- lamp (2) flashes.

For more information, you must open the *Error* submenu.

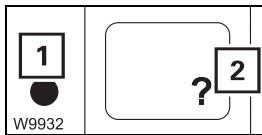

- Press the button (2) once. The button is only active when the lamp (1) flashes or lights up.

The *Error* submenu opens.

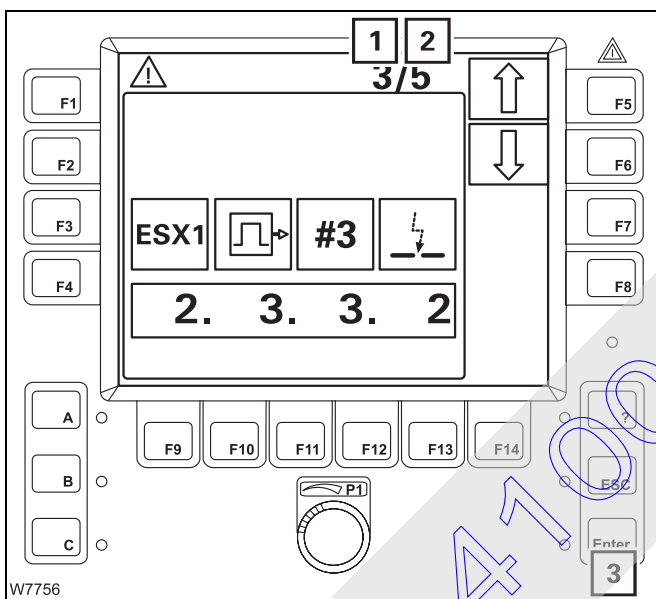

Display of error / total errors

Display (2) shows the error total, and display (1) shows which error is displayed.

3/5, for example, means:

- that error 3 is shown
- there is a total of 5 errors.

If the error shown is not acknowledged, the lamp next to the button (3) lights up.

To acknowledge the error

- Press the button (3) once.

If there are further errors, the next error is displayed and can be acknowledged.

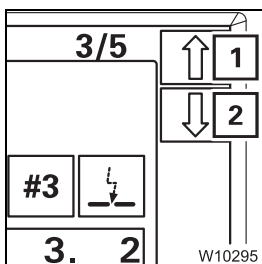



- When all errors have been acknowledged, you can retrieve any pending errors using the buttons next to the symbols (1) and (2).

- 1 Next error
- 2 Previous error

Every time you press, the next error will be displayed.

When you keep a button held down, all errors are shown one after the other continuously.



If not all errors have been acknowledged, the buttons   have no function – the symbols are grey.



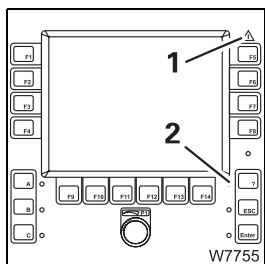

When all error messages have been acknowledged, the displays change:

- lamp (1) lights up and
- lamp (2) lights up.

Both displays start to flash again as soon as a new error occurs.

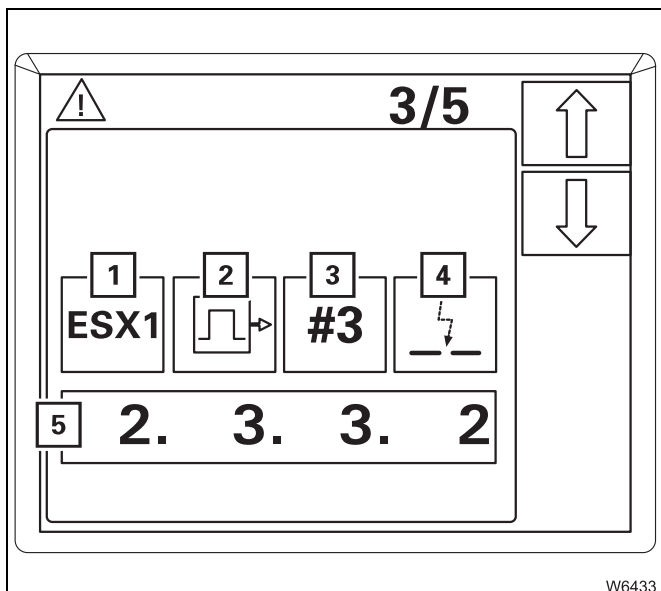

Error display

Each error is defined by an error code (5) and the symbols (1) to (4).

The symbols stand for:

- 1 the faulty device
- 2 the error group
- 3 the index within the group
- 4 the type of error

The error code (5) consists of four digits, e.g. 2332.

- Always note down the error code before contacting **CraneCARE**.

Exiting the sub-menu



You can exit the *Error* sub-menu at any time.

- Press the button (1) once.

The same menu opens which was open before the *Errors* submenu opened.



All errors remain saved until you switch off the ignition, even those errors of which the cause has been eliminated in the meantime. All existing errors are treated as new errors and displayed again after turning on the ignition.

On the control units



Switching on the error display

- Press the button (1) and additionally the button (2) once.

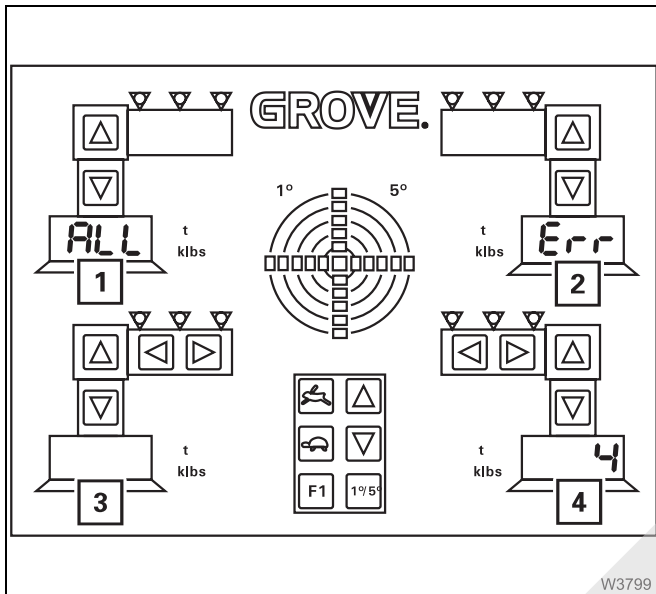

The error display is switched on.

The displays (1) to (4) show e.g.

ALL	Err
	4

The number in field (4) shows the total number of stored error messages (e.g. 4).

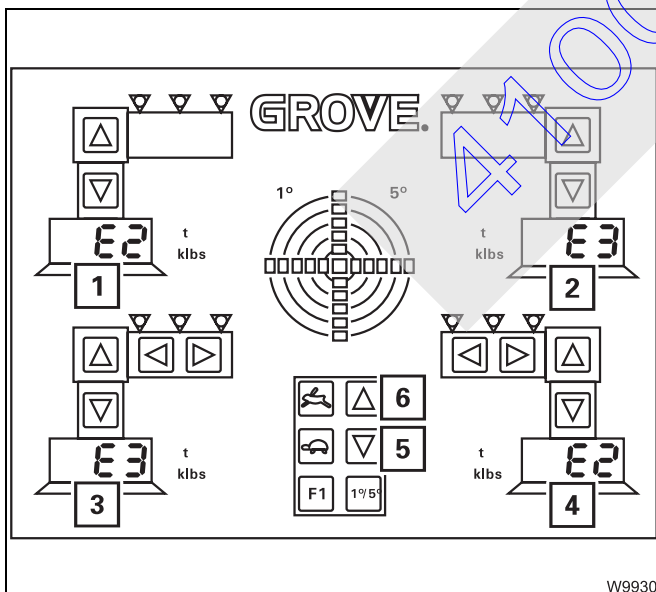

Displaying error codes

- Press the button (5) once. The oldest error in the memory is shown.

Displays (1) to (4) show the figures for the error code, e.g. 2. 3. 3. 2.

You can retrieve all the stored error codes one after the other.

- To show the
 - next error code, press button (6)
 - previous error code, press button (5)

Switching off the error display

- Press the button (1) and additionally the button (2) once.

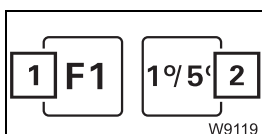

Blank page

41005067

7.7

Procedure in the event of malfunctions

7.7.1

Switching on emergency operation in coolant circuit

For cooling purposes, the fan wheel of the engine is switched on and off automatically. When this automatic system fails, you can switch on emergency operation so that the fan wheel always runs when the engine is switched on.

- Switch off the engine and secure against unauthorized use – lock the hand-held control in the driver's cab and the doors.



Risk of accidents due a turning fan wheel

Always switch off the engine and secure against unauthorized use before switching on emergency operation.

This prevents the fan wheel from starting to turn suddenly, and injuring you.



Risk of burning yourself when the engine is hot

During operation, the engine and the add-on parts heat up to a great extent. Wear appropriate protective gloves and be careful not to touch hot parts.

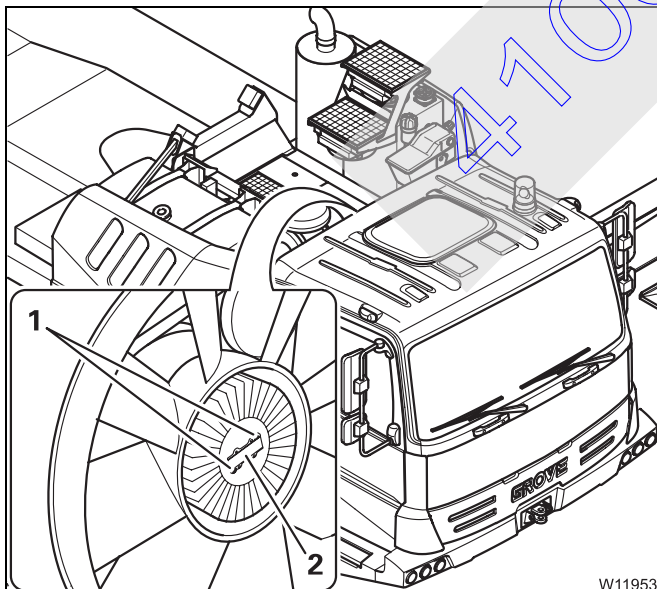

Emergency operation is switched on at the fan wheel's hub.

- Undo the screws (1).
- Turn the metal plate (2) and remove it.
- Press in the pin under the metal plate.
- Emergency operation is activated and the fan wheel will run continuously as long as the engine has been switched on.

With a blocked fan wheel, you may only drive up to 1000 km (620 mi).

7.7.2

Procedure in the event of malfunctions to the transmission and engine

If the transmission or engine malfunctions, the electronic system will try to establish a secure operating condition with the remaining functions.

Engine

- If you are requested to stop by the text on the *On-board computer* display, or when the engine capacity is automatically reduced, stop the truck crane immediately, taking into account the traffic situation.

Severe engine malfunction

If the **STOP** lamp lights up or the warning buzzer sounds:

- Turn off the engine.



Risk of damage to the engine

Turn off the vehicle engine immediately after stopping the truck crane. Do not by any means restart the engine. Serious damage to the engine can be avoided this way.

- Read the error codes (▮▮▮▮ p. 5 - 26) and contact **CraneCARE**.

Other engine malfunctions

- Turn off the engine.
- Switch off the ignition and wait about 15 seconds, then switch it on again.
- Switch off the battery master switch and wait about 15 seconds, then switch it on again.

If the malfunction is still present:

- Check the texts of all messages (▮▮▮▮ *Error information*, p. 5 - 24) and conduct the measures shown, as far as is possible (e.g. top up oil).

If the malfunction cannot be remedied,

- read the error codes (▮▮▮▮ p. 5 - 26) and contact **CraneCARE**.

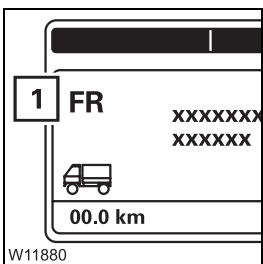

Transmission

If the transmission no longer shifts automatically, you can continue driving until you next have an opportunity to stop. Depending on the type of malfunction, it is possible to shift gear to *Manual* mode.

- Stop at the next opportunity.
The clutch is disengaged if possible after letting go of the accelerator. If it is not possible to disengage the clutch, the engine will be throttled when the truck crane is halted.
- Turn off the engine.
- Check the texts of all messages (▣▣▣▣ *Error information*, p. 5 - 24) and conduct the measures shown, as far as is possible (▣▣▣▣ *Error information*, p. 5 - 24).

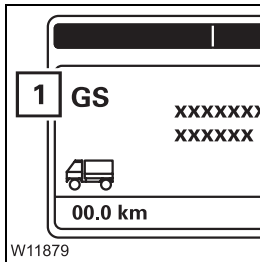

If the malfunctions are still present:

- Switch into neutral position, if this is still possible
- Switch off the ignition and wait about 15 seconds, then switch it on again
- If it is still impossible to engage a starting gear, switch off the battery master switch and wait about 15 seconds, then switch it on again
- If no starting gear can be engaged, check whether you can operate the vehicle using the emergency programme.

If the transmission cannot be operated using the emergency programme, read off the error codes (▣▣▣▣ p. 5 - 26) and contact **CraneCARE**. If necessary, you can only shift the gear mechanically in emergency mode; ▣▣▣▣ p. 7 - 41.



Transmission emergency program submenu

Shifting and driving with the transmission emergency program should only be done in an emergency. If necessary, contact **CraneCARE** before using the transmission emergency program.

- The submenu should only be opened when the transmission no longer reacts to the operating elements.

The submenu must be opened to shift to **NH** mode for towing away;

▣▣▣▣ *Switching on towing mode, p. 7 - 7.*

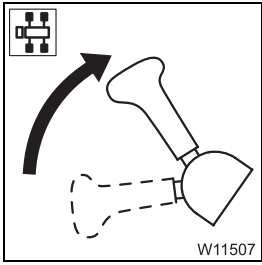

Opening the submenu and determining the current status

- Stop the truck crane
- Engage the parking brake



Danger from truck crane rolling unexpectedly

Always engage the parking brake before you shift gears in the *Transmission emergency program* submenu.

In this way you prevent the truck crane from suddenly starting to roll, e.g. when the clutch is engaged.

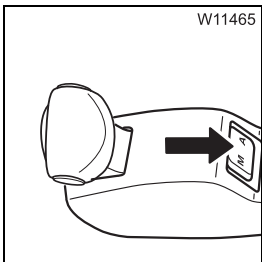

- Switch to *Automatic* operating mode – position **A**.

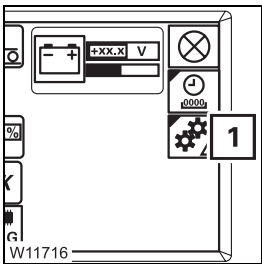

- Press the button next to the (black) symbol (1) once.
The *Transmission emergency program* submenu opens.

If the symbol (1) is grey, the transmission emergency program has been blocked and the only possibility is to carry out a mechanical emergency gear shift; ▣▣▣▣ p. 7 - 41.



After opening the submenu, the *On-board computer* display has no function.

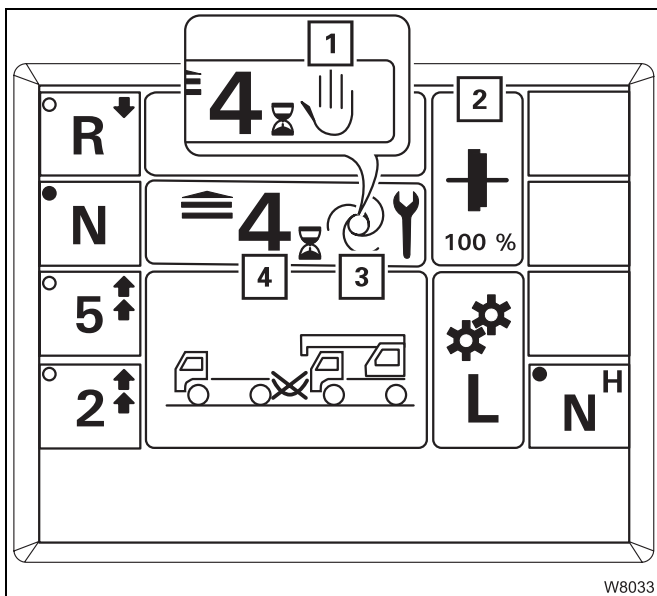

The submenu opens and indicates the current status:

- The display (4) shows the currently selected gear or neutral position, e.g. the fourth gear.
- The display (2) shows the symbol for the current position and the corresponding percentage, e.g. *Engaged* – 100%.
- The *Automatic* symbol (3) or *Manual* symbol (1) is displayed, depending on the selected operating mode.
- The symbol **N** is **black**.

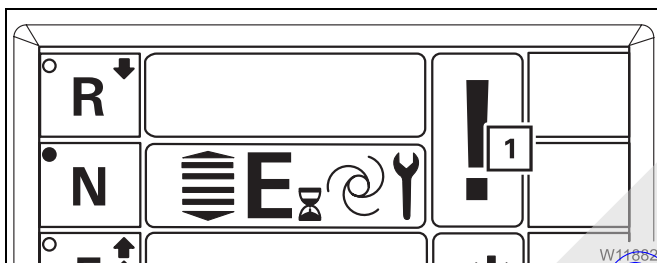

If a display is not available, the symbol (1) appears there, e.g. on the *Clutch* display.

The entry **E** appears when operation is not possible with the emergency programme.

Various types of operation are possible, regardless of the available displays.

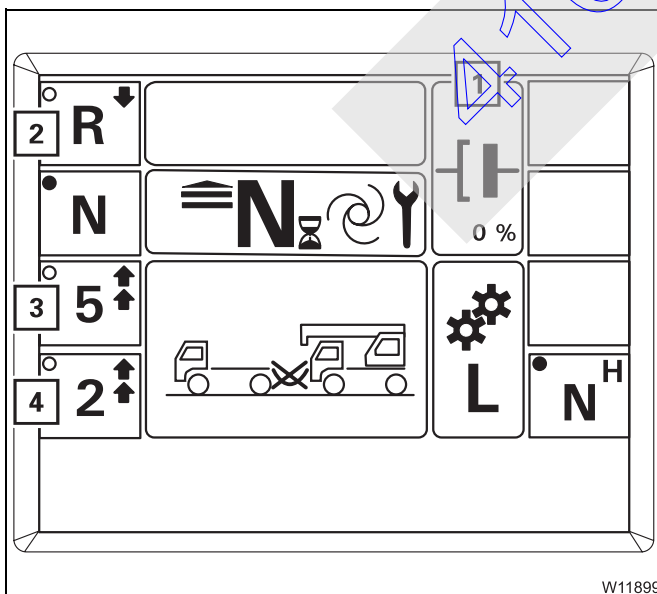

- Press the button **N** once.

If possible, neutral position is selected and the clutch is released.

The value under the display (1) is **0%** if the clutch is completely released.

If the clutch is not or only partially released, this means there is a malfunction in the clutch control and gears can only be selected mechanically in emergency mode;

►► p. 7 - 41.

If the symbols (2) to 4) are black, the corresponding gears can be selected.



Selecting a gear



The following information is based on the assumption that the clutch is released and is being operated automatically.

The exact sequence of the procedure must always be adapted to the current malfunction, if necessary after consulting **CraneCARE**.

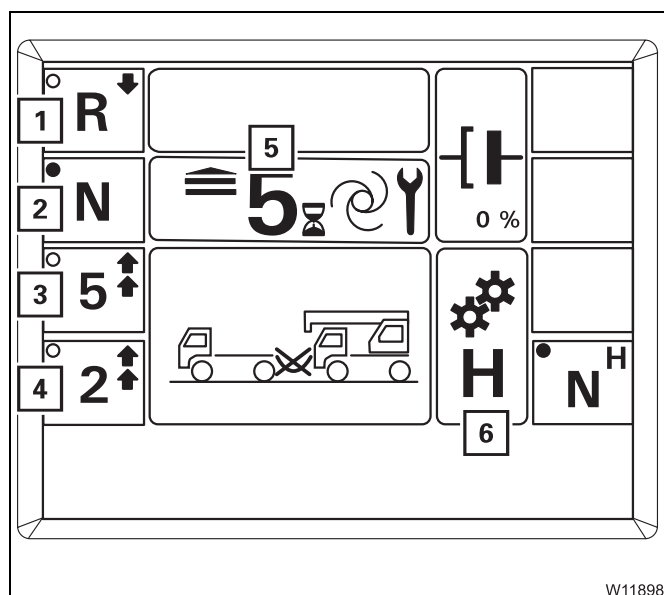

- Press the button next to the corresponding symbol to select a gear or the neutral position.

- 1 Reverse gear
- 2 Neutral position
- 3 Fifth gear
- 4 Second gear

If the gear is engaged, it is indicated on the display (5), e.g. fifth gear.

The display (6) shows

- Entry H in fifth gear
- Entry L in second gear

Starting and driving in the transmission emergency program

- Actuate the accelerator.

– Once the truck crane starts:

Now the transmission switches while you drive, provided this is possible despite the malfunction.

– If the truck crane does not start:

- Release the accelerator.
- Press the switch (1) where it says **M** – *Manual* operating mode.
- Actuate the accelerator.

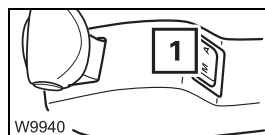

The truck crane starts and you can only drive in the gear engaged.

You can switch to neutral position at any time in both operating modes. In this case you can only downshift to a starting gear, however, with the truck crane at a standstill.

Stopping

The clutch is disengaged automatically when the accelerator is released, if this is still possible.

If automatic disengaging is no longer possible, the vehicle engine will be throttled as soon as you stop the truck crane using the service brake.

Switching gears mechanically in emergency mode

If you park the truck crane in gear and the pressure in the reservoirs falls below 5.5 bar (80 psi), you can

- Not start the engine since the transmission is not in neutral position
- Not shift the transmission into neutral position because the pressure is below 5.5 bar (80 psi) and
- Not fill the reservoir because the engine is not running

In this situation, you can shift the transmission mechanically into neutral position in order to start the engine.

In addition you can also shift the transmission mechanically to neutral position or select a gear if it is no longer possible to select gears with the operating elements in the driver's cab.



Danger of accidents and injuries

Always engage the parking brake and switch off the engine before selecting a gear.

In this way, you can prevent the truck crane from rolling unexpectedly or the selector shaft from suddenly returning, catching your hand and injuring it.

The following requirements must be met before you are able to shift gears in emergency mode:

- The truck crane is stationary
- The parking brake is engaged
- The engine is switched off
- The clutch is released and the display (1) indicates the symbol *Open* (0%). After switching gears in emergency mode, you may only start the engine if the clutch is released.
- The ignition is switched off

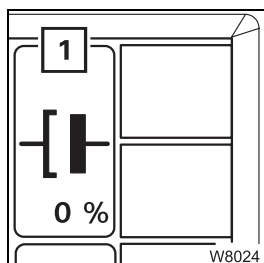

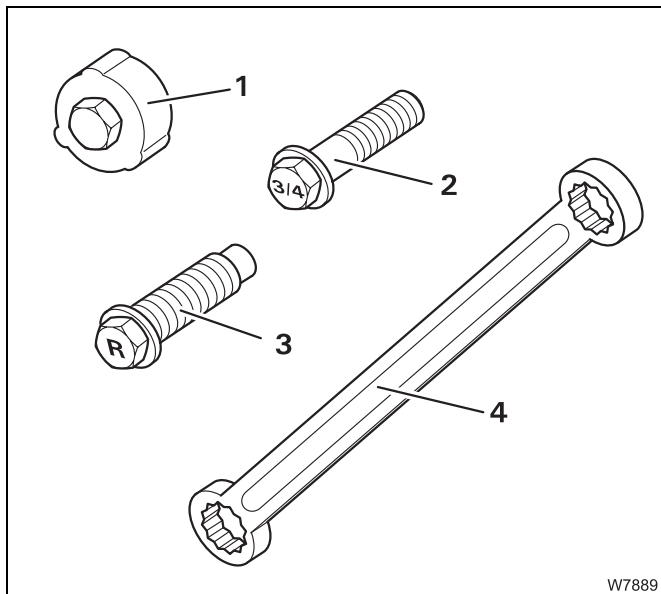

The following accessories are supplied in order to shift gears mechanically in emergency mode.

- An adapter (1) for switching to neutral position or into first or second gear
 - The 3/4 bolt (2) for switching into third or fourth gear
 - The R (3) bolt for switching into reverse gear
- You also need an appropriate spanner (4).

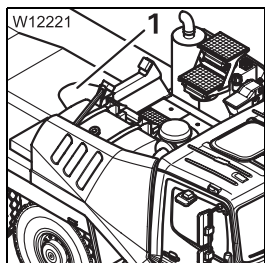

- Remove the plate (1).

The selector shaft is at the front, on the left side of the transmission under the hydraulic pumps.

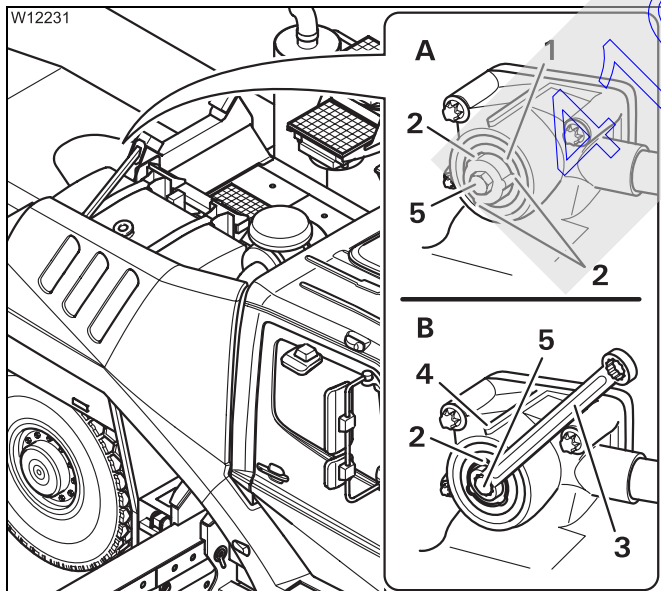

Switching to neutral position

- Pull the cap from the selector shaft (1)
- (A) – Apply the adapter (5) to the selector shaft (1) in such a way that it is flush with the cutouts (2)
- (B) – Push the adapter (5) into the cutouts (2) as far as it will go and apply an appropriate spanner (3)
- Turn the selector shaft until a cutout (2) is below the mark (4)

The transmission is now in neutral position.

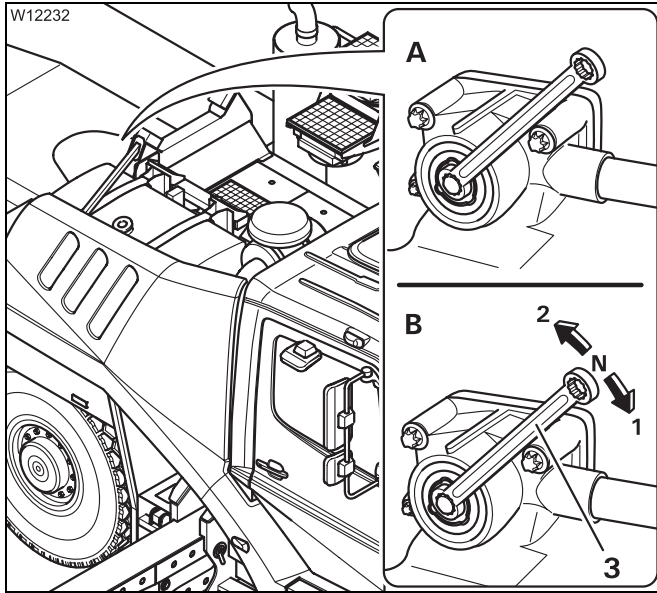

Selecting the first or second gear

- (A) – Apply the adapter to the selector shaft and switch to neutral position.
- (B) – Turn the selector shaft in the required direction with the spanner (3) until it engages at the stop.
 - Clockwise into the position (1) for the first gear
 - Anticlockwise into the position (2) for the second gear

Switch to the neutral position and repeat the switching procedure if the selector shaft does not engage.

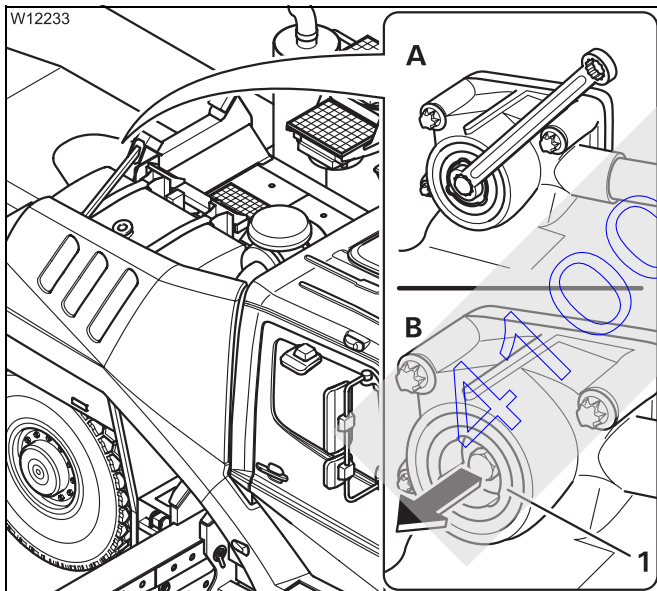

Selecting the third, fourth or reverse gear

- (A) – Apply the adapter to the selector shaft and switch to neutral position.
- (B) – Remove the adapter and screw the screw plug out of the selector shaft (1).

For the third or fourth gear you now need the 3/4 bolt.

For the reverse gear you now need the R bolt.



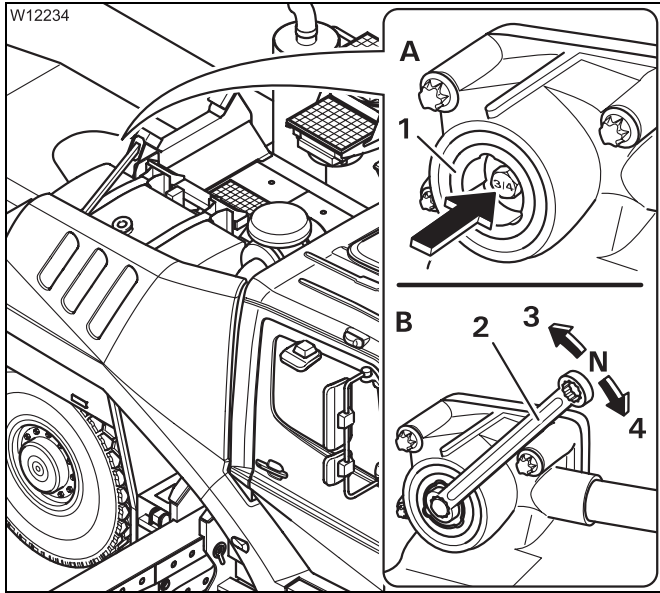

For third and fourth gear

- **(A)** – Screw the 3/4 bolt into the selector shaft (1) as far as it will go and tighten it.
- **(B)** – Apply the adapter to the selector shaft and turn the selector shaft with the spanner (2) in the appropriate direction.
 - Anticlockwise to the position (3) for the third gear
 - Clockwise to the position (4) for the fourth gear

Switch to the neutral position and repeat the switching procedure if the selector shaft does not engage.

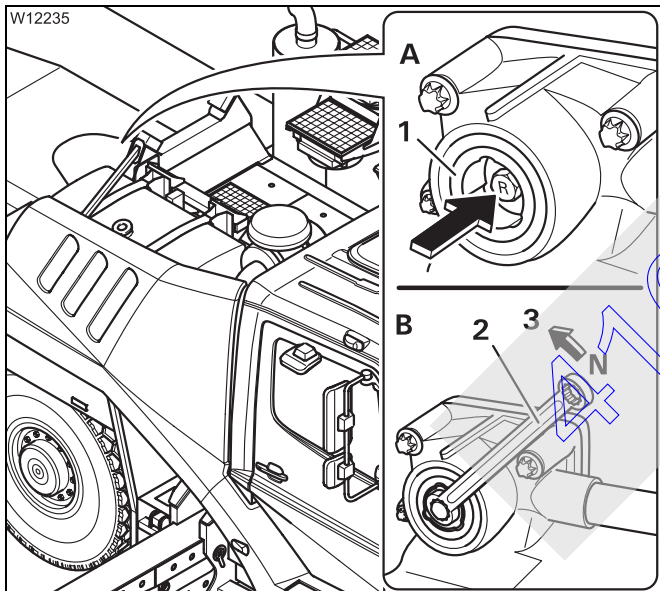

For reverse gear

- **(A)** – Screw the R bolt into the selector shaft (1) as far as it will go and then screw it out again about 3/4 revolution.
- **(B)** – Apply the adapter to the selector shaft and turn the selector shaft with the spanner (2) anticlockwise to the position (3).

Switch to the neutral position and repeat the switching procedure if the selector shaft does not engage.

Starting and driving

If it is still possible to operate the clutch automatically, the clutch engages automatically when the accelerator is operated and the truck crane starts to move.

You can only drive in the gear selected mechanically. It is not possible to change gears while driving.

ID number of the transmission

The ID number of the transmission is on the model plate.

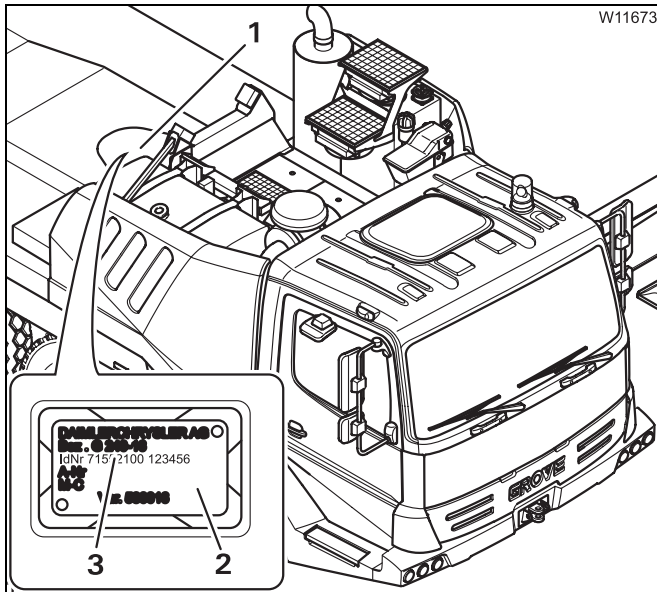

- Remove the rear cover plate (1).

The model plate (2) is on top of the transmission.

The ID number (3) consists of an eight-digit number and a six-digit number. You must add the digits 00 to the first number on the model plate if it only consists of six digits.

In this example the ID number is 71552100 123456

- Note down the ID number, on this page for example, so that you can find it at a later time.

41005067

Blank page

41005067

8 Technical information on the carrier

8.1 Technical data 8 - 1

8.1.1 Dimensions and weights of the truck crane, axle loads 8 - 2

8.1.2 Dimensions and weights of removable parts. 8 - 4

8.1.3 Carrier 8 - 5



41005067

8

Technical information on the carrier

8.1

Technical data

GROVE truck crane GMK 4100

Permissible temperature range: -25 °C to $+40\text{ °C}$ (-13 °F to $+104\text{ °F}$)

41005067

8.1.1

Dimensions and weights of the truck crane, axle loads

The dimensions in the illustration are given in mm.

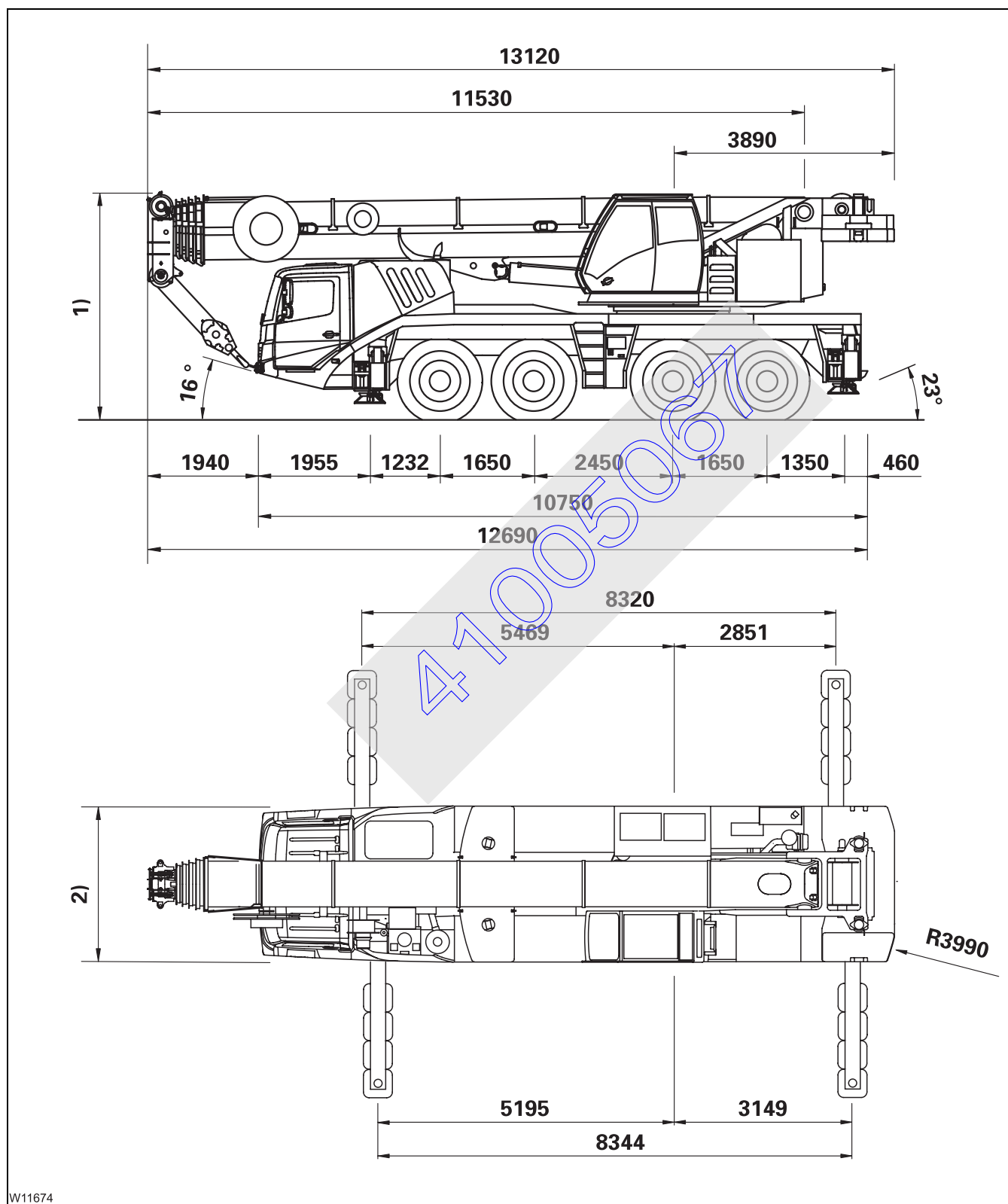

W11674

23.11.2006



Dimensions

All measurements relate to the on-road driving mode;  *Driving modes*, p. 6 - 1.

Length without auxiliary hoist:	13.12 m (43 ft)
1) Height:	At on-road level:
– 14.00 R25	3.94 m (12.9 ft)
– 16.00 R25 / 20.5 R	3.99 m (13.1 ft)
Max. level change	-130/+170 mm (-5.1/+6.7 in)
2) Width:	
– 14.00 R25	2.75 m (9.0 ft)
– 16.00 R25	2.75 m (9.0 ft)
– 20.5 R25	2.98 m (9.5 ft)
Angle of negotiable banks:	at on-road level (14.00 R25)
front:	approx. 16°
rear:	approx. 23°

Weight and axle loads

For equipment with the specified axle loads in on-road mode;  *Driving modes*, p. 6 - 1.

Dimensions and weights of the parts which have to be transported on separate vehicles when driving on roads;  p. 8 - 4 and  p. 16 - 2.

Total weight:	depending on the driving mode, 48 t (105 800 lbs)
Axle loads:	depending on the driving mode, 12 t (26 500 lbs)
Axle loads ¹⁾	25.0 t (55 100 lbs) in working position, free-standing

- 1) The axle loads given relate to driving with a rigged truck crane and the maximum load which can be lifted according to *Lifting capacity table*.

8.1.2

Dimensions and weights of removable parts

This section contains the dimensions and weights of the parts which can be removed for on-road driving;  *Driving modes*, p. 6 - 1.

Spare wheel

Description	Length x width x height in m (ft)	Weight in kg (lbs)	
		1)	2)
Spare wheel 14.00 R 25	1.36 x 1.36 x 0.40 (4.45 x 4.45 x 1.30)	245 (540)	220 (485)
Spare wheel 16.00 R 25	1.50 x 1.50 x 0.45 (4.95 x 4.95 x 1.50)	310 (685)	250 (551)
Spare wheel 20.5 R 25	1.50 x 1.50 x 0.53 (4.92 x 4.92 x 1.74)	355 (785)	325 (772)

1) with steel rim

2) with aluminium rim

Outriggers

Description	Length x width x height in m (ft)	Weight in kg (lbs)
Plastic outrigger pads	0.50 x 0.50 x 0.20 (1.65 x 1.65 x 0.66)	28 (61)
Steel outrigger pads	0.50 x 0.50 x 0.20 (1.65 x 1.65 x 0.66)	36 (79)

8.1.3

Carrier

Engine

Mercedes-Benz:	OM 460 LA
Power:	295 kW (400 HP) at 1800 min ⁻¹ (EC 80 / 1269 - 89 / 491 EEC, fan detached)
Engine emissions:	EUROMOT \ EPA \ CARB (off road)
Fuel tank:	approx. 400 l (106 gal)

Transmission

16 gear levels forwards, 2 gear levels backwards.

Transfer case

2-stage

Axle lines

Drive:	8 x 6 x 8
First axle line:	Steered and driven axle line
Second axle line:	Steered and driven axle line, drive can be activated
Third axle line:	Steered and driven axle line, steering can be switched on
Fourth axle line:	Steered and driven axle line

Steering

Dual-circuit hydraulic steering with emergency steering pump which operates independently of the engine

Tyres

8 x 14.00 R 25 on disk wheels 9.50-25 /1.7
8 x 16.00 R 25¹⁾ on 11.00-25/1.7 disk wheels
8 x 20.5 R 25¹⁾ on 17.00-25/1.7 disk wheels

¹⁾ Additional equipment

Torque for wheel nuts: 650 Nm (480 lbf ft).

Tyre pressure with cold tyres for axle loads up to max. 12 t

14.00 R25:	10 bar (145 psi)
16.00 R25:	9 bar (131 psi)
20.5 R25:	7 bar (102 psi)



Electrical system

Alternator:	28 V / 100 A
Batteries:	2 x, each of 12 V / 170 Ah
Voltage:	24 V

Tools

1 tool kit in tool box
Wheel chocks (number according to national regulations)

Towing couplings

Front towing coupling:	100 kN (22,480 lbf) permissible tension ¹⁾
Rear tow lug:	75 kN (16 860 lbf) permissible tension ¹⁾

¹⁾ Only permissible if a particular tension angle is observed;  p. 5 - 70

Outriggers

Design:	4-point telescoping outrigger system
Control system:	Can be controlled from both sides on the carrier and individually from the crane cab.
Outrigger spans:	8.332 x 7.00 m (27.3 x 23.0 ft) 8.332 x 6.00 m (27.3 x 19.6 ft) 8.332 x 5.00 m (27.3 x 16.4 ft) 8.332 x 4.00 m (27.3 x 13.2 ft) 8.332 x 2.54 m (27.3 x 8.4 ft)
Outrigger pads	Size: 500 x 500 mm (19.6 x 19.7 in) Surface: 2500 cm ² (388 in ²)
Stroke of support cylinders	front and back: 500 mm (19.7 in)
Inclination indicator:	On the hand-held control, in the crane cab, on the <i>outrigger</i> operating units.
Outrigger pressure indicator:	Depending on the design in the outriggers, integrated with a display in the crane cab and on the <i>outrigger</i> operating units.

Driving speeds At an engine speed of 1800 min⁻¹

Forwards: max. 85.0 km/h (52.8 mph)

Reverse: approx. 7 km/h (4.3 mph) depending on the tyres

Climbing ability Transport weight 48 t (105 800 lbs)

14.00 R25 tyres: 70%

16.00 R25 tyres: 63%

20.5 R25 tyres: 63%

Turning circle radiuses The dimensions in the illustration are given in mm.

R = values for normal steering mode

Ra = values for all-wheel steering

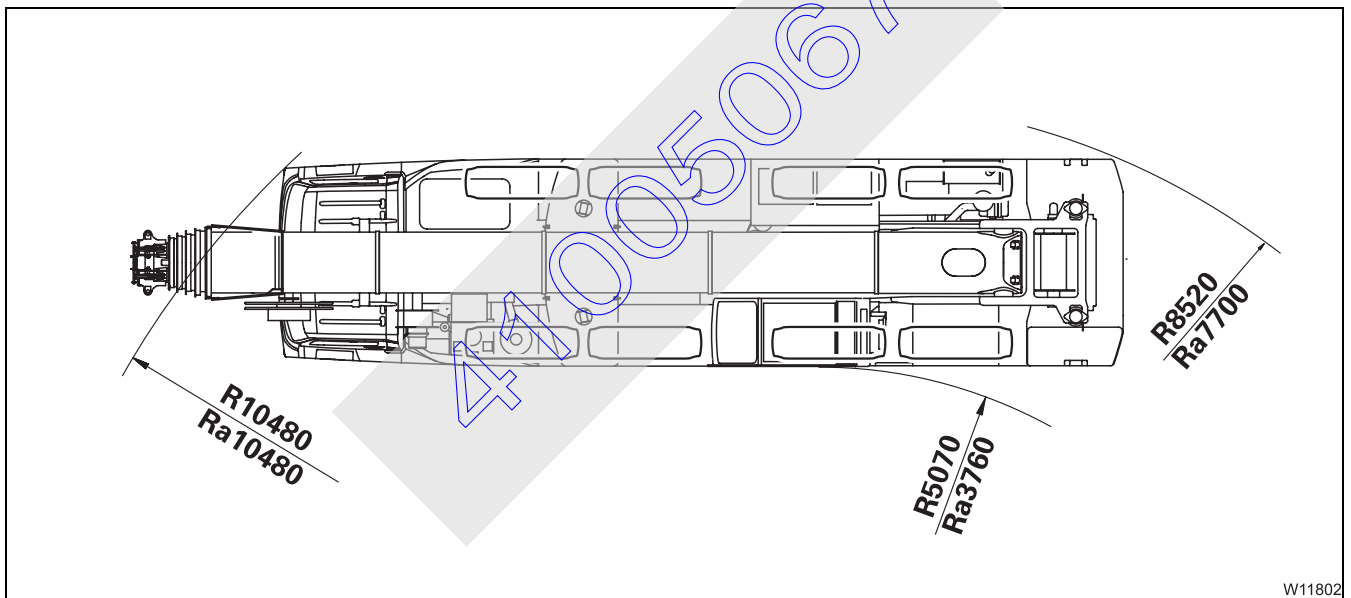

Blank page

41005067

9 Index



41005067

9

Index



To avoid making the index unnecessarily long and unclear, we have not included every single element from the instrument panel.

Those elements, such as switches and buttons, lamps and displays are described and named in detail in the overviews of chapter 3 and chapter 10, *Description of the truck crane*.

You are referred to more detailed descriptions of these elements from there as usual.

41005067

Blank page

41005067

A	Access ladders on the carrier	4 - 5
	Adjusting the mirrors	
	for crane operation	13 - 114
	for driving	5 - 7
	Adjusting the seat	
	in the driver's cab	5 - 11
	Air intake inhibitor	4 - 23
	on the engine for crane operation	11 - 21
	Air-conditioning system	
	in the crane cab	12 - 125
	in the driver's cab	5 - 78
	Auxiliary heater	
	fuel reserve	12 - 5
	Auxiliary hoist	12 - 48
	lifting and lowering	12 - 49
	short description of the operating elements	10 - 70
	switching off	12 - 50
	switching on	12 - 48
	Axle loads	
	required speed limit	6 - 6
	when driving with a rigged truck crane	14 - 3
B	Battery master switch	4 - 8
	superstructure	11 - 7
	Boom floating position	
	switching off	13 - 17
	switching on	6 - 9
	Boom pre-tensioning	
	switching off	13 - 19
	switching on	6 - 10
	Brakes	
	additional brakes	3 - 45, 5 - 46
	compressed-air supply in the event of engine failure	7 - 6
	operating elements in the driver's cab	3 - 43
	parking brake	3 - 44
	checking for correct functioning	5 - 10
	towing a trailer	
	checking the braking force	5 - 90

C	Carrier hydraulic system	
	checking the valves on the hydraulic tank	4 - 8
	CHECKLIST	
	extending the outriggers	13 - 25
	if the temperature is low	
	crane operation	11 - 4
	driving	4 - 4
	inspections before on-road driving	5 - 1
	inspections prior to crane operation	12 - 1
	retracting the outriggers	13 - 27
	rigging counterweight	13 - 59
	rigging for crane operation	13 - 1
	starting the engine for crane operation	11 - 1
	unrigging counterweight	13 - 60
	unrigging following crane operation	13 - 5
	Choosing a site	13 - 9
	Compressed air system	
	building up supply pressure	5 - 9
	see Brakes	
	Constant speed	
	see Tempomat	
	Counterweight	
	automatic mode, rigging	13 - 74
	automatic mode, unrigging	13 - 75
	CHECKLIST	
	rigging counterweight	13 - 59
	unrigging counterweight	13 - 60
	counterweight parts	13 - 55
	counterweight versions	
	assembling	13 - 61
	overview, version A	13 - 64
	Overview, version B	13 - 66
	Overview, version C	13 - 68
	extending / retracting the lifting cylinders	13 - 73
	identification	13 - 57
	mounting counterweight on the turntable	13 - 78
	opening the submenu	13 - 72
	pre-tensioning	13 - 74
	removing counterweight from the turntable	13 - 79
	short description of the operating elements	10 - 65
	slewing with rigged counterweight	13 - 82
	slinging points	13 - 58
	Crane cab	
	adjusting the front panel and crane cab seat	12 - 7
	air-conditioning system	12 - 125
	drying the air	12 - 127
	auxiliary air heater	12 - 134
	auxiliary water heater	12 - 127
	door	10 - 97
	inclining	12 - 95
	operating elements	

auxiliary air heater	10 - 13
auxiliary water heater	10 - 12
control lever assignment	10 - 16
on the control panels	10 - 14
on the ECOS control unit	10 - 18
on the ECOS display	
main menu	10 - 20
submenus	10 - 22
on the front panel	10 - 6
on the hand-held control	10 - 44
on the outrigger control units	10 - 46
on the side panel	10 - 7
on the SLI control unit	10 - 40
standard heating system	10 - 11
overview	10 - 4
standard heating system	12 - 123
ventilating	12 - 124
windows	10 - 97
windscreen washing system	12 - 5
Crane cab, driving	14 - 7
after driving	14 - 21
operating the transmission	14 - 15
possible connections	14 - 19
longitudinal differential locks	14 - 20
preparations	14 - 8
starting	14 - 17
starting / turning off the engine	14 - 11
steering	
adapt steering direction	14 - 12
normal steering	14 - 13
separate steering	14 - 14
switching on the steering	14 - 12
warning messages	14 - 18
while driving	14 - 17
Crane operation	
CHECKLIST – inspections prior to crane operation	12 - 1
if the temperature is low – CHECKLIST	11 - 4
permissible slewing ranges	12 - 43
preheating the hydraulic oil	12 - 13
rigging – CHECKLIST	13 - 1
unrigging – CHECKLIST	13 - 5
what to do in the event of malfunctions	15 - 3
D Derricking gear	12 - 54
raising and lowering the boom	12 - 55
short description of the operating elements	10 - 73
switching off	12 - 56
switching on	12 - 54
Diagnostics plug	10 - 96

Differential locks	
see Longitudinal differential locks	
see Transverse differential locks	
Display, driver's cab	
messages while driving	5 - 50
overview	3 - 10
short description, on-board computer	3 - 54
Display, driver's cab	
on-board computer	
settings / displays	
operation	5 - 22
overview of the menus	5 - 23
Displays during crane operation	
error message	12 - 106
operating hours	12 - 101
warning message	12 - 102
Displays while driving	
error message	5 - 50
on the driving display	5 - 50
warning message	5 - 48
Documentation supplied	1 - 6
Driver's cab	
adjusting the mirrors	5 - 7
adjusting the seats	5 - 11
air-conditioning system	5 - 78
auxiliary heater	5 - 80
doors	3 - 57
keys	3 - 57
operating elements	
auxiliary air heater	3 - 25
on the ECOS display	3 - 16
on the instrument panel	3 - 7
on the steering column	3 - 11
standard heating system	3 - 24
transmission	3 - 12
overview	3 - 4
standard heating system	5 - 75
windows	3 - 56
Driving	
brakes	
additional brakes	5 - 46
downhill	5 - 44
if the temperature is low – CHECKLIST	4 - 4
inspections before driving	5 - 6
inspections before driving – CHECKLIST	5 - 1
inspections while driving	5 - 39
off-road	5 - 61
uphill	5 - 47
what to do in the event of malfunctions	7 - 3
with Tempomat	5 - 41
with tempopset	5 - 43

Driving from the crane cab	
opening/closing the Driving mode submenu	14 - 8
Driving modes	
tables for maximum axle loads of 12 t	6 - 3
using the tables	6 - 2
Driving the rigged truck crane	14 - 1
E Earthing	
of the truck crane	13 - 13
the load	12 - 12
ECOS	
adjusting the brightness of the display – in the crane cab	11 - 11
adjusting the brightness of the display – in the driver's cab	4 - 12
operating elements in the crane cab	
brief description	10 - 55
in counterweight submenu	10 - 22, 10 - 36
in submenu for outriggers	10 - 24
in the driving submenu	10 - 38
in the Error submenu	12 - 106
in the main menu	10 - 20
in the monitoring submenu	10 - 29
in the power unit speed submenu	10 - 28
in the Settings submenu	
operating hours	12 - 101
in the settings submenu	10 - 30
in the slewing gear/Houselock submenu	10 - 23
in the telescoping submenu	10 - 26
in the Warning submenu	12 - 102
on the control unit	10 - 18
operating elements in the driver's cab	
brief description	3 - 34
in the Error submenu	3 - 23, 5 - 50
in the level adjustment system submenu	3 - 18
in the main menu	3 - 16
in the Settings submenu	3 - 20
operating hours	5 - 21
in the Transmission emergency program submenu	3 - 22
in the Warning submenu	3 - 21, 5 - 48
on the control unit	3 - 14
Electrical system	
display and operating elements in the crane cab	10 - 89
fuses in the superstructure	15 - 6
inspections in the crane cab	12 - 7
inspections in the driver's cab	5 - 6
operating elements in the driver's cab	3 - 34
SLI fuses	15 - 11

Emergency operation	
emergency operation in coolant circuit	7 - 35, 15 - 55
hydraulic emergency operation	
activating/deactivating emergency operation	15 - 59
after emergency operation	15 - 66
connecting/disconnecting hoses	15 - 58
emergency supply of another crane	15 - 67
establishing the required hydraulic circuits	15 - 60
operating principle	15 - 57
hydraulic emergency operation BGR 159	15 - 57
telescoping mechanism	
emergency operation for retracting	15 - 36
inspections prior to emergency operation	15 - 36
performing mechanical emergency operations	15 - 37
procedures for retracting	15 - 36
entering the telescoping status after emergency operation	15 - 49
telescoping emergency program	15 - 39
with the hand-held control	15 - 51
Emergency stop devices	
Engine for crane operation	11 - 20
for the engine	4 - 22
Emergency stop switch	
for crane operation	15 - 1
for driving	7 - 1
Engine for crane operation	
after starting the engine	
lamp test / equalisation of the switching states	11 - 9
air intake inhibitor	11 - 21
inspections after starting the engine	11 - 14
inspections before starting the engine	11 - 7
malfunctions	15 - 13, 15 - 22
preheating	12 - 128
refuelling	
additional tank	11 - 6
standard tank	11 - 5
setting the idling speed	11 - 16
starting	11 - 12
starting – checklist	11 - 1
switch on the ignition	11 - 8
turning off	
during normal operation	11 - 19
in emergencies	11 - 20
Engine for driving	
air intake inhibitor	4 - 23
diagnostics	3 - 53
malfunctions	7 - 23
operation in the driver's cab	
checking after starting	4 - 16
checking the fuel level	4 - 7
checks before starting	4 - 8
control elements	4 - 17
lamp test / equalisation of the switching states	4 - 10

resetting the emergency stop switch	4 - 22
setting the idling speed	4 - 19
starting	4 - 13
starting – CHECKLIST	4 - 1
switching on the ignition	4 - 9
turning off	4 - 21
procedure in the event of malfunctions	7 - 36
refuelling	4 - 7
starting from the crane cab – for rigging work	13 - 21
Engine, for crane operation	
short description of the operating elements	10 - 51
F Final drive	
operating elements in the driver's cab	3 - 42
Front flap	
opening and closing	3 - 58
Fuel tank	
engine for crane operation	11 - 5
standard tank	4 - 7
Fuses	
on the carrier	7 - 17
in the battery box	7 - 22
in the driver's cab	7 - 18
on the superstructure	15 - 5
for the SLI	15 - 11
in the crane cab	15 - 8
on the turntable	15 - 6
H Hand-held control	
disconnecting	13 - 20
malfunctions	15 - 22
Heating system	
crane cab	
auxiliary air heater	12 - 134
auxiliary water heater	12 - 127
standard heating system	12 - 123
driver's cab	
auxiliary heater	5 - 80
standard heating system	5 - 75
High speed	12 - 86
derricking gear / telescoping mechanism high-speed mode	12 - 86
high-speed mode, hoisting gears	12 - 87
switch on function	12 - 86

Hoist rope	
checking the position	12 - 6
positioning and reeving in	13 - 92
possible reeving on the main boom	
with 7 head sheaves	13 - 96
with 8 head sheaves	13 - 99
rope end clamp	13 - 90
unreeving	13 - 95
Hook block	
attaching it to the bumper	13 - 86
picking it up from the separate vehicle	13 - 87
picking up from the bumper	13 - 85
placing it on a separate vehicle	13 - 87
Horn	3 - 48
Houselock	
switching off	12 - 16
switching on	12 - 14
Hydraulic system of the superstructure	
check valve on hydraulic tank	11 - 7
hydraulic oil cooling	12 - 93
preheating the hydraulic oil	12 - 13
Hydraulic system, superstructure	
short description of the operating elements	10 - 81
I Identification	
of the counterweight sections	13 - 57
of the truck crane	1 - 1
Inclination display	
short description of the operating elements	10 - 63
Inclination displays	13 - 46
Information	
about the operating instructions	1 - 7
conversion table for US measurements	1 - 15
for operations planning	1 - 14
technical information on the carrier	8 - 1
Inspections	
before driving	5 - 6
for the safety devices	12 - 9
vehicle height	5 - 8
Installing / removing the air traffic control light	13 - 108
Installing / removing the anemometer	13 - 108

K	Keys	
	for the carrier	3 - 57
	for the superstructure	10 - 98
L	Ladders and access ladders	4 - 5
	Level adjustment system	
	changing the vehicle level	5 - 67
	exiting the submenu	5 - 68
	opening the submenu	5 - 65
	operating elements	3 - 50
	pre-selecting suspension struts	5 - 66
	setting the on-road level	5 - 66
	viewing the current inclination	5 - 67
	Lifting limit switch	
	installing	13 - 102
	locking	13 - 106
	removing	13 - 105
	removing the lock	13 - 107
	Lighting	3 - 49
	driver's cab, inside	3 - 50
	hazard warning system	3 - 49
	operating elements in the crane cab	10 - 89
	outriggers	3 - 49
	parking light / headlight – full beam	3 - 48
	rotating beacon	3 - 49, 3 - 50
	superstructure lighting	6 - 12
	turn signal indicator	3 - 48
	Load, earthing	12 - 12
	Longitudinal differential locks	
	operation from the crane cab	14 - 20
	operation from the driver's cab	5 - 63
	while towing	7 - 8
M	Main boom	
	lower to the horizontal	12 - 56
	Main hoist	12 - 45
	folding hoist mirror out / in	13 - 114
	lifting and lowering	12 - 46
	short description of the operating elements	10 - 68
	switching off	12 - 47
	switching on	12 - 46
	Malfunctions	
	carrier hydraulic system	7 - 28
	counterweight hoist unit	15 - 21
	derricking gear	15 - 16
	differential locks	7 - 28

during crane operation	15 - 3
ECOS – carrier	7 - 30
error display on the control units	7 - 33
error messages on the display	7 - 31
ECOS – superstructure	15 - 32
error messages	15 - 33
engine	
in crane operation	15 - 22
in driving mode	7 - 23
engine for crane operation	15 - 13
hand-held control	15 - 22
hydraulic system of the superstructure	15 - 22
inclining the crane cab	15 - 22
level adjustment system	7 - 29
main hoist	15 - 15
outriggers	15 - 24
procedure in the event of malfunctions	7 - 35
safe load indicator	15 - 25
service brake	7 - 26
slewing gear	15 - 20
steering	7 - 27
suspension	7 - 29
telescoping mechanism	15 - 17
transmission	7 - 25, 7 - 27
when driving from the crane cab	15 - 23
Movement combinations	
when operating with the main boom	12 - 92
O Off-road driving	5 - 61
On-board computer	
general operation	3 - 54
Operating elements	
for driving from the crane cab	10 - 99
in the crane cab – overview	10 - 4
in the driver's cab – overview	3 - 4
Operating instructions	
example of how to use cross-references	1 - 12
finding information	1 - 11
structure of the chapters and pages	1 - 9
symbols used	1 - 7
Outrigger pressure display	13 - 53
Outrigger pressure displays	
short description of the operating elements	10 - 64
Outriggers	13 - 25
CHECKLIST – Extending	13 - 25
CHECKLIST – Retracting	13 - 27
determining the required ground bearing area	13 - 9
enlarging the ground bearing area	13 - 39
extending / retracting outriggers	13 - 32

	from the control units	13 - 33
	from the crane cab	13 - 36
	with the hand-held control	13 - 34
	extending / retracting supporting cylinders	13 - 41
	from the control units	13 - 42
	from the crane cab	13 - 44
	with the hand-held control	13 - 43
	levelling the truck crane on outriggers	
	automatically	13 - 49
	inclination displays	13 - 46
	manually	13 - 48
	outrigger pads	
	moving into driving position	13 - 38
	moving into working position	13 - 38
	outrigger pressure display	13 - 53
	permissible outrigger spans	13 - 28
	preparing the truck crane for rigging	13 - 29
	setting the spans	13 - 30
	short description of the operating elements	10 - 58
	Overview	
	operating elements – crane operation	10 - 1
	operating elements – driving	3 - 1
P	Parking brake	
	operating elements	3 - 44
	while towing	7 - 8
	Push-up roof	3 - 56
R	Railings on the turntable	13 - 113
	Refuelling	
	standard tank	4 - 7
	Rigged truck crane, driving	
	axle loads	14 - 3
	before driving	
	checking the tyre pressure/wind speed	14 - 4
	driving from the driver's cab	14 - 5
	rigging modes	
	driving with load	14 - 3
	driving without a load	14 - 2
	route	14 - 2
	Rigging for on-road driving	
	for driving with a trailer	6 - 7
	switching on boom floating position	6 - 9
	switching on boom pre-tensioning	6 - 10
	switching on the slewing gear freewheel	6 - 8
	switching the superstructure driving lights on / off	6 - 12

Rigging mode	
entering on the SLI	12 - 21
Rigging work	
main boom	
attaching the hook block to the bumper	13 - 86
picking up the hook block from the bumper	13 - 85
picking up the hook block from the separate vehicle	13 - 87
placing the hook block on the separate vehicle	13 - 87
other rigging work	
folding mirror in / out	13 - 114
folding out the railings on the turntable	13 - 113
outriggers	13 - 25
rigging for crane operation – CHECKLIST	13 - 1
unrigging following crane operation – CHECK LIST	13 - 5
Rotating beacons (controlled from the crane cab)	10 - 89
S Safe distance	
from electrical lines	13 - 14
to slopes and pits	13 - 12
Safe load indicator	
short description of the operating elements	10 - 83
Safety	
basic safety instructions	2 - 1
intended use	2 - 1
Safety devices	
checking	12 - 9
Seat, adjusting	
in the crane cab	12 - 7
Separate steering	5 - 71
steering with separate steering	5 - 72
switching to normal steering mode	5 - 73
switching to separate steering	5 - 71
Settings before driving	
adjusting the brightness of the display	4 - 12
Settings during crane operation	
adjusting the brightness of the display	11 - 11
adjusting the power unit speeds	12 - 96
adjusting the wiper stroke interval	12 - 96
critical load control	12 - 99
directional spotlights	12 - 100
inclining the crane cab	12 - 95
setting the characteristic curve for the control levers	12 - 98
setting the constant idling speed	12 - 95
Slewing gear	
braking the slewing movement	12 - 91
short description of the operating elements	10 - 71
slewing	12 - 88

slewing gear freewheel	12 - 91
slewing to 0° and 180°	12 - 90
switching off	12 - 92
Slewing gear freewheel	
switching off	13 - 18
switching on	6 - 8
SLI	
displaying / entering the time and date	12 - 39
during crane operation	12 - 31
entering the rigging mode	12 - 21
finding and eliminating malfunctions	15 - 25
error messages	15 - 26
general malfunctions	15 - 25
fuses	15 - 11
lamp test	12 - 20
operating elements	10 - 40
overriding the SLI	12 - 38
SLI early warning	12 - 35
SLI shutdown	12 - 36
due to overload	12 - 36
switching on	12 - 18
SLI lamp test	12 - 20
Spotlights	10 - 89
Starting to tow	7 - 10
Steering	
in the crane cab	14 - 12
operating elements in the driver's cab	3 - 46
Steering column	
adjusting	5 - 13
Storage compartment	3 - 58
Superstructure lock	
see houselock	
Suspension	
locking (switching off)	5 - 14
operating elements in the driver's cab	3 - 47
switching on / off	5 - 14
T Tachograph	5 - 16
inserting diagram sheets	5 - 18
setting time groups	5 - 19
Tachograph / speedometer	
operating elements	3 - 52
Technical data	8 - 1, 16 - 1
carrier	8 - 5
dimensions and weights of removable parts	8 - 4, 16 - 2
dimensions, weights, axle loads of the truck crane	8 - 2
maximum lifting capacity	16 - 1

operating speeds	16 - 5
superstructure	16 - 4
Telescoping mechanism	12 - 57
assignment for display	12 - 60
error messages	15 - 18
function of the control lever	12 - 65
inspections prior to starting operations	12 - 64
main boom fixed length	12 - 62
main boom intermediate length	12 - 62
main boom telescoping length	12 - 62
manual telescoping	12 - 68
checking the initial position	12 - 68
extending / retracting the telescoping cylinder	12 - 73
locking the telescopic section	12 - 78
locking the telescopic section for on-road driving	12 - 79
telescoping the telescopic section	12 - 77
unlocking the telescoping cylinder	12 - 71
overview	12 - 58
short description of the operating elements	10 - 74
switching off	12 - 67
switching on	12 - 65
telescopic extension with teleautomation	12 - 80
telescoping process	12 - 58
telescoping sequence	12 - 63
telescoping the main boom for maintenance	12 - 85
telescoping the main boom in horizontal position	12 - 85
telescoping, ECOS display	12 - 77
telescoping, SLI display	12 - 63
Tempomat	5 - 41
Temposet	5 - 43
Towing	7 - 5
compressed-air supply in the event of engine failure	7 - 6
electric power supply	7 - 6
in the event of engine or transmission damage	7 - 6
parking brake	7 - 8
towing the truck crane out of the danger area	7 - 9
Towing a trailer	5 - 85
Towing free	
backwards	5 - 70
forwards	5 - 70
Transfer case	5 - 62
operating elements in the driver's cab	3 - 41
Transmission	
diagnostics plug	3 - 53
ID number	7 - 45
operating in the emergency program	7 - 38
operation from the driver's cab	
changing gears while driving	5 - 34
changing the driving direction	5 - 36
changing the operating mode	5 - 30
display of the gears	5 - 31

on the roller type dynamometer	5 - 37
selecting and changing the starting gear	5 - 31
starting	5 - 33
stopping	5 - 37
switching on	5 - 29
switching to neutral position	5 - 30
procedure in the event of malfunctions	7 - 36
switching gears mechanically in emergency mode	7 - 41
Transverse differential locks	
operation from the crane cab	14 - 20
operation from the driver's cab	5 - 63
while towing	7 - 8
Trip recorder	
see Tachograph	
Truck crane	
checking the horizontal alignment	12 - 41
earthing	13 - 13
Identification	1 - 1
overview of the carrier	3 - 2
rocking free	5 - 69
safe distance	12 - 41
securing against rolling away	5 - 58
towing free	
backwards	5 - 70
forwards	5 - 70
turning off	5 - 58
Tyres	
see Wheels and tyres	
V Voltage indicator lamp	
carrier	4 - 18
superstructure	10 - 89
W Warning plates for vehicle width	5 - 8
Welding work	
safety instructions	2 - 4
Wheels and tyres	
filling the tyres yourself	7 - 15
wheel change	7 - 11
Windscreen washing system	
tank – driver's cab	5 - 6
Windscreen wiper	3 - 48
crane cab	10 - 91
driver's cab	3 - 48
Windscreen wiper / washing system	10 - 89

Windscreen, washing system	
tank – driver's cab	12 - 5
Work break	12 - 121
short work breaks	12 - 121
work breaks of more than 8 hours	12 - 122
Working range limiter	12 - 107
entering limit values by approaching them	
for objects	12 - 113
for overall height / working radius	12 - 110
for slewing angles	12 - 111
entering limit values manually	
for objects	12 - 117
for overall height / working radius / slewing angle	12 - 116
opening the Working range limiter submenu	12 - 108
shutdown	12 - 119
switching monitoring function on / off	12 - 118
view current settings	12 - 108

41005067

GROVE®

GMK 4100

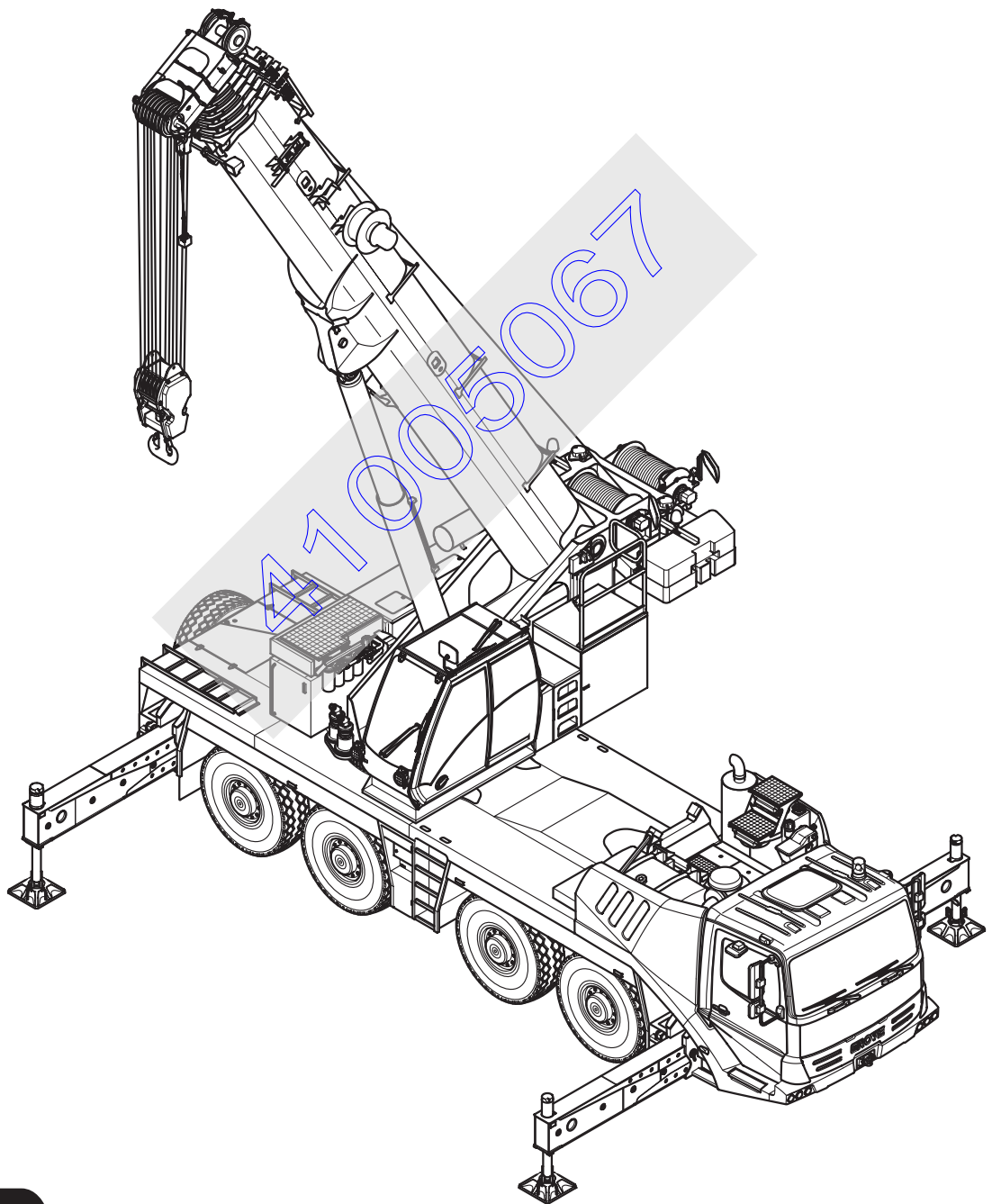

41005067

Manitowoc Crane Group Germany GmbH

Industriegelände West,
D-26389 Wilhelmshaven, Germany
Postfach 18 53,
D-26358 Wilhelmshaven, Germany
Fax: Int [+49] (0) 44 21 294-301
Tel: Int [+49] (0) 44 21 294-0
www.manitowoccranegroup.com

GROVE[®]

GMK 4100

Operating instructions Part 2 – Crane operation

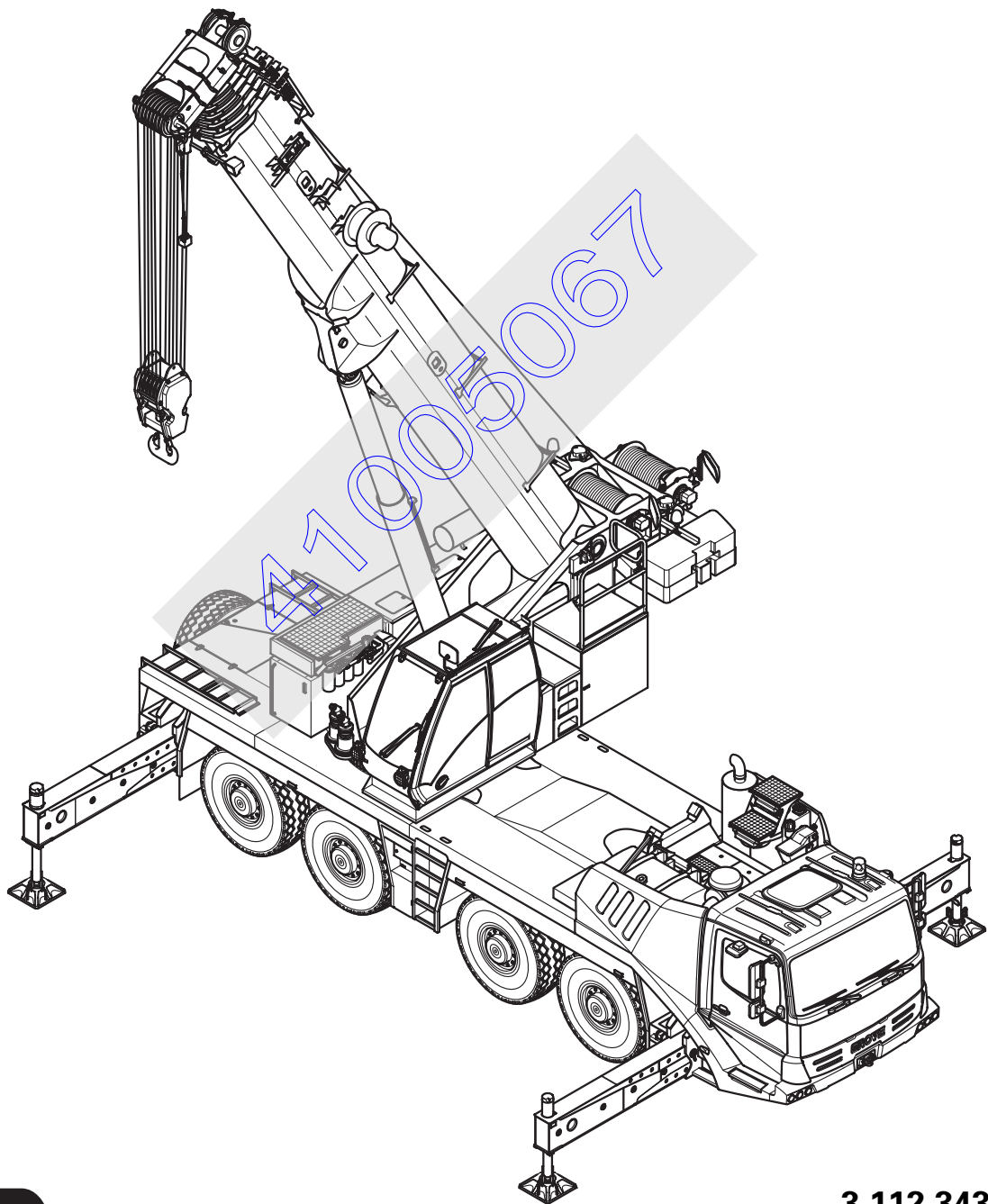

3 112 343 en
23.11.2006

Serial number

Manitowoc[®]
Crane Group

A **Manitowoc** Company

Important note

Any type of duplication or excerpt from this document, also in electronic form, are not subject to the revision service of **Manitowoc Crane Group Germany GmbH**.

41005067

© Copyright reserved by **Manitowoc Crane Group Germany GmbH**

Dissemination or duplication of this document as well as utilization and disclosure of its contents are prohibited unless expressly permitted. Infringement will incur liability for compensation. All rights pertaining to registration of patent or utility model are reserved.

23.11.2006

These operating instructions are divided into two parts:

Part 1 – Driving

Part 2 – Crane operation

Contents overview Part 2:

- 10 Operating elements for crane operation**
- 11 Starting / turning off the engine – for crane operation**
- 12 Crane operation**
- 13 Rigging work**
- 14 Driving the rigged truck crane**
- 15 Malfunctions during crane operation**
- 16 Technical information for the superstructure**
- 17 Index**

Chapters 1 to 9 are in Part 1 – Driving

**This section alone does not make up the complete operating instructions.
The basic safety instructions for crane operation are located in Section 1, Chapter 2.**

Blank page

41005067

10 Operating elements for crane operation

10.1	Overview of the operating elements	10 - 1
10.1.1	On the outside of the truck crane	10 - 2
10.1.2	Crane cab	10 - 4
10.1.3	Front panel	10 - 6
10.1.4	Side panel	10 - 7
10.1.5	Control panels	10 - 14
10.1.6	Control lever assignment	10 - 16
10.1.7	ECOS control unit	10 - 18
10.1.8	ECOS display – main menu	10 - 20
10.1.9	ECOS display – submenus	10 - 22
10.1.10	SLI control unit	10 - 40
10.1.11	Hand-held control	10 - 44
10.1.12	Outrigger control units	10 - 46
10.2	Short description of the operating elements	10 - 49
10.2.1	Definition of positional references	10 - 49
10.2.2	General rules for buttons and symbols on the display	10 - 50
10.2.3	Engine for crane operation	10 - 51
10.2.4	Engine for driving	10 - 53
10.2.5	Seat contact switch and dead man's switch	10 - 54
10.2.6	ECOS crane control	10 - 55
10.2.7	Outriggers	10 - 58
10.2.8	Inclination displays	10 - 63
10.2.9	Outrigger pressure displays	10 - 64
10.2.10	Anemometer display	10 - 64
10.2.11	Counterweight submenu	10 - 65
10.2.12	Main hoist	10 - 68
10.2.13	Auxiliary hoist	10 - 70
10.2.14	Slewing gear	10 - 71
10.2.15	Derricking gear	10 - 73
10.2.16	Telescoping mechanism	10 - 74
10.2.17	Hydraulic system	10 - 81
10.2.18	Houselock	10 - 82
10.2.19	Safe load indicator (SLI)	10 - 83
10.2.20	Electrical system	10 - 89
10.2.21	Lighting, windscreen wiper / washing system	10 - 89
10.2.22	Hand-held control	10 - 92
10.2.23	Diagnostics	10 - 96
10.2.24	Windows, doors, keys	10 - 97

10.3	Short description of the operating elements – driving from the crane cab. . .	10 - 99
10.3.1	Driving submenu	10 - 99
10.3.2	Engine for driving	10 - 100
10.3.3	Transmission	10 - 101
10.3.4	Final drive	10 - 102
10.3.5	Brakes	10 - 103
10.3.6	Steering	10 - 104



10

Operating elements for crane operation

All operating elements for driving are described in chapter 3.

10.1

Overview of the operating elements

This section shows the position and designations of the operating elements for crane operation. This also includes display elements such as lights or displays.



Operating elements which are only available for additional equipment are designated accordingly. These designations are made in this section only and are not repeated in the following sections.

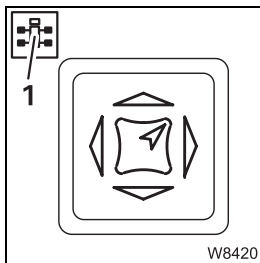

Some figures show details from a different perspective than the total view. The perspective is indicated by the symbol (1).

41005067

10.1.1

On the outside of the truck crane

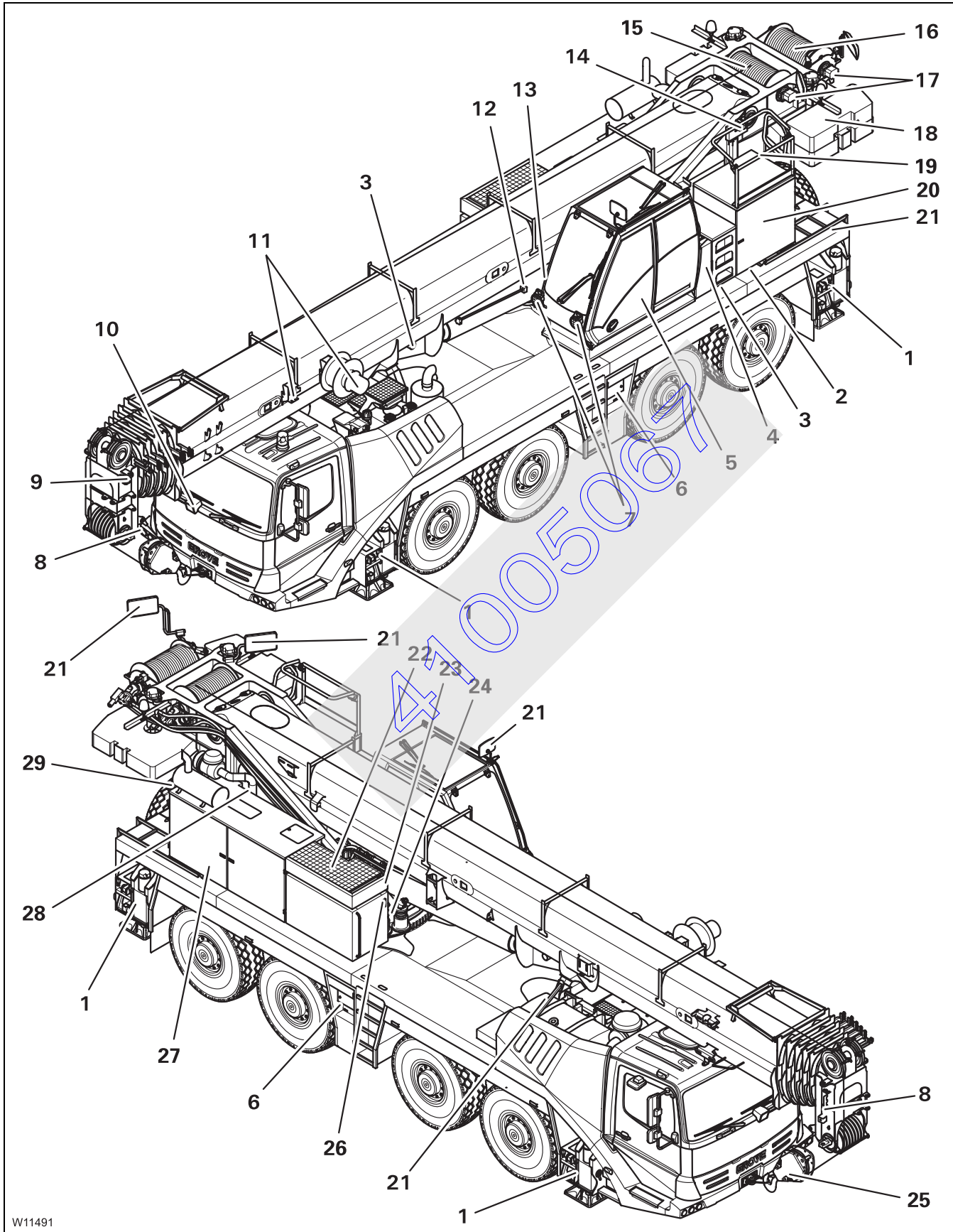

W11491

23.11.2006

1	Outriggers	▣▣▣▣ p. 13 - 25
	Outrigger lighting	▣▣▣ p. 3 - 49
2	Battery master switch	▣▣▣ p. 11 - 7
3	Sockets for hand-held control	▣▣▣ p. 10 - 92
4	Auxiliary heater – tank ¹⁾	▣▣▣ p. 12 - 5
5	Crane cab	▣▣▣ p. 10 - 4
6	Sockets for hand-held control	▣▣▣ p. 10 - 92
	Outrigger control units ¹⁾	▣▣▣ p. 10 - 46
	Emergency stop switch	▣▣▣ p. 15 - 1
7	Spotlights ¹⁾	▣▣▣ p. 10 - 89
8	Lifting limit switch – function	▣▣▣ p. 12 - 51
	Lifting limit switch – rigging	▣▣▣ p. 13 - 102
9	Anemometer and air traffic control light ¹⁾	▣▣▣ p. 13 - 108
10	Slewable working area spotlight ¹⁾	▣▣▣ p. 12 - 100
11	Data transmitter ²⁾	
12	Switching off the boom floating position	▣▣▣ p. 13 - 17
	Switching off boom pre-tensioning	▣▣▣ p. 13 - 19
13	Central lubrication ^{1), 2)}	
14	Hydraulic emergency operation	▣▣▣ p. 15 - 57
15	Main hoist	▣▣▣ p. 10 - 68
16	Auxiliary hoist ¹⁾ or 0.6 t weight	▣▣▣ p. 10 - 70
17	Lowering limit switch	▣▣▣ p. 12 - 53
18	Counterweight	▣▣▣ p. 13 - 55
19	Folding railing	▣▣▣ p. 13 - 113
20	Fuel tank ¹⁾	▣▣▣ p. 11 - 6
21	Mirror for crane operation ¹⁾	▣▣▣ p. 13 - 114
22	Hydraulic oil cooler, second cooler ¹⁾	▣▣▣ p. 12 - 93
23	Valve for hydraulic oil preheating	▣▣▣ p. 12 - 13
24	Slewing gear	▣▣▣ p. 12 - 88
	Switching off the slewing gear freewheel	▣▣▣ p. 13 - 18
25	Hook block	▣▣▣ p. 13 - 85
26	Hydraulic oil tank, inspection glass ²⁾	
	Valve on hydraulic tank	▣▣▣ p. 11 - 7
27	Engine for crane operation	▣▣▣ p. 11 - 1
	Oil dipstick / filler neck for engine ²⁾	
28	Air intake inhibitor ¹⁾	▣▣▣ p. 11 - 21
29	Coolant reservoir, engine ²⁾	

¹⁾ Additional equipment

²⁾ ▣▣▣ *Maintenance manual*

10.1.2

Crane cab

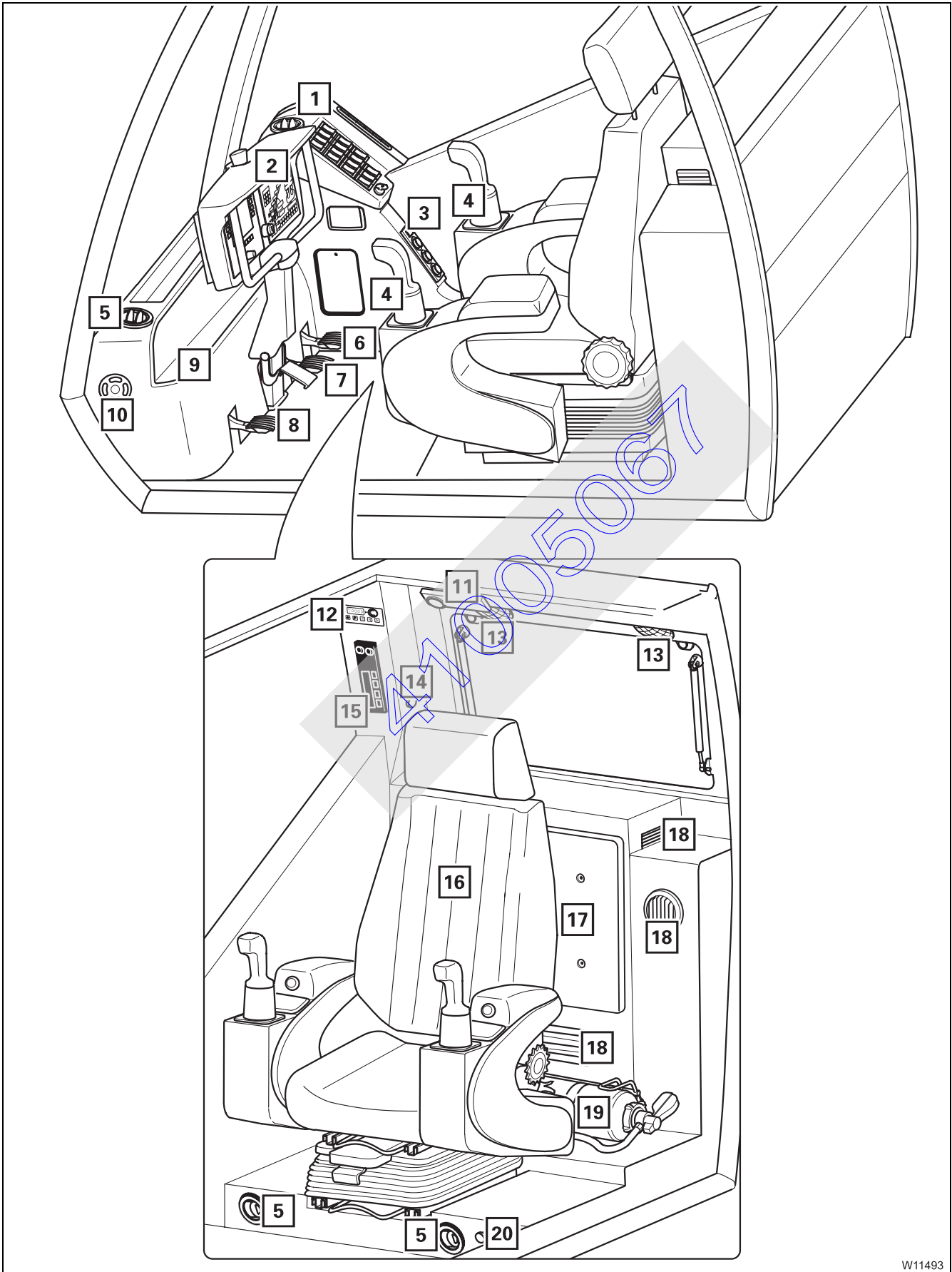

W11493

1	Side panel	▶▶▶▶▶ p. 10 - 7
2	Front panel	▶▶▶▶▶ p. 10 - 6
3	Standard heating system	▶▶▶▶▶ p. 10 - 11
4	Control panels	▶▶▶▶▶ p. 10 - 14
5	Air vent	▶▶▶▶▶ p. 12 - 124
6	Accelerator	
7	Service brake brake pedal	▶▶▶▶▶ p. 10 - 103
8	Slewing gear brake	▶▶▶▶▶ p. 12 - 91
9	Storage compartment	
10	Tank for windscreen washing system	▶▶▶▶▶ p. 12 - 5
11	Cab lighting	▶▶▶▶▶ p. 10 - 90
12	Auxiliary water heater	▶▶▶▶▶ p. 10 - 12
	Auxiliary air heater	▶▶▶▶▶ p. 10 - 13
13	Loudspeakers	
14	Socket (12 V) ¹⁾	
15	Radio cassette player ^{1), 3)}	
	Radio CD player ^{1), 2)}	
16	Crane cab seat – Version 1	▶▶▶▶▶ p. 12 - 7
	Crane cab seat – Version 2	▶▶▶▶▶ p. 12 - 8
	Seat contact switch	▶▶▶▶▶ p. 10 - 54
17	Detachable cover with fuses behind it	▶▶▶▶▶ p. 15 - 8
18	Suction / air vents	▶▶▶▶▶ p. 12 - 123
19	Fire extinguisher ²⁾	
20	Door unlocking mechanism	▶▶▶▶▶ p. 10 - 98

¹⁾ Additional equipment

²⁾ ▶▶▶▶▶ *Maintenance manual*

³⁾ ▶▶▶▶▶ *Separate operating instructions*

10.1.3

Front panel

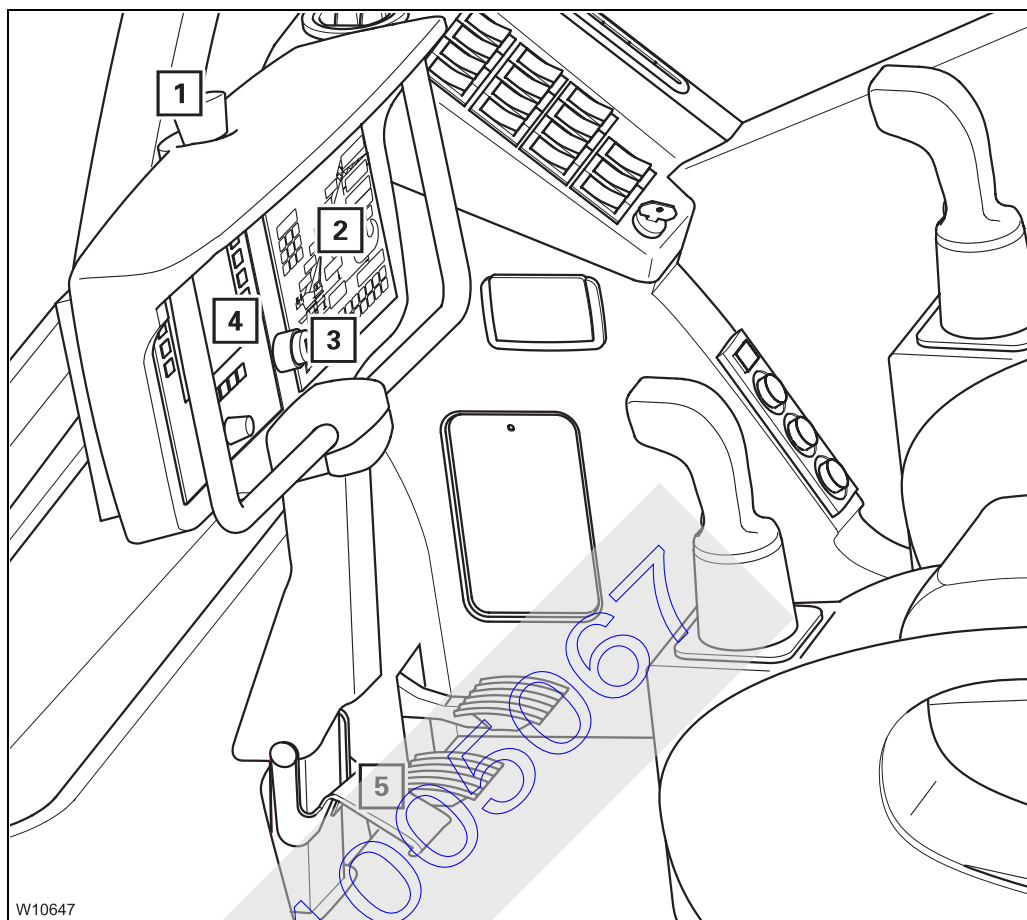

- | | |
|--|------------------|
| 1 Emergency stop switch | ▣▣▣▣▶ p. 10 - 57 |
| 2 SLI Control unit (S afe L oad I ndicator) | ▣▣▣▣▶ p. 10 - 40 |
| 3 Key-operated override switch
– for SLI
– for SLI and lifting limit switch | ▣▣▣▣▶ p. 10 - 88 |
| 4 ECOS control unit | ▣▣▣▣▶ p. 10 - 18 |
| 5 Front panel | ▣▣▣▣▶ p. 12 - 8 |

10.1.4

Side panel

Bottom

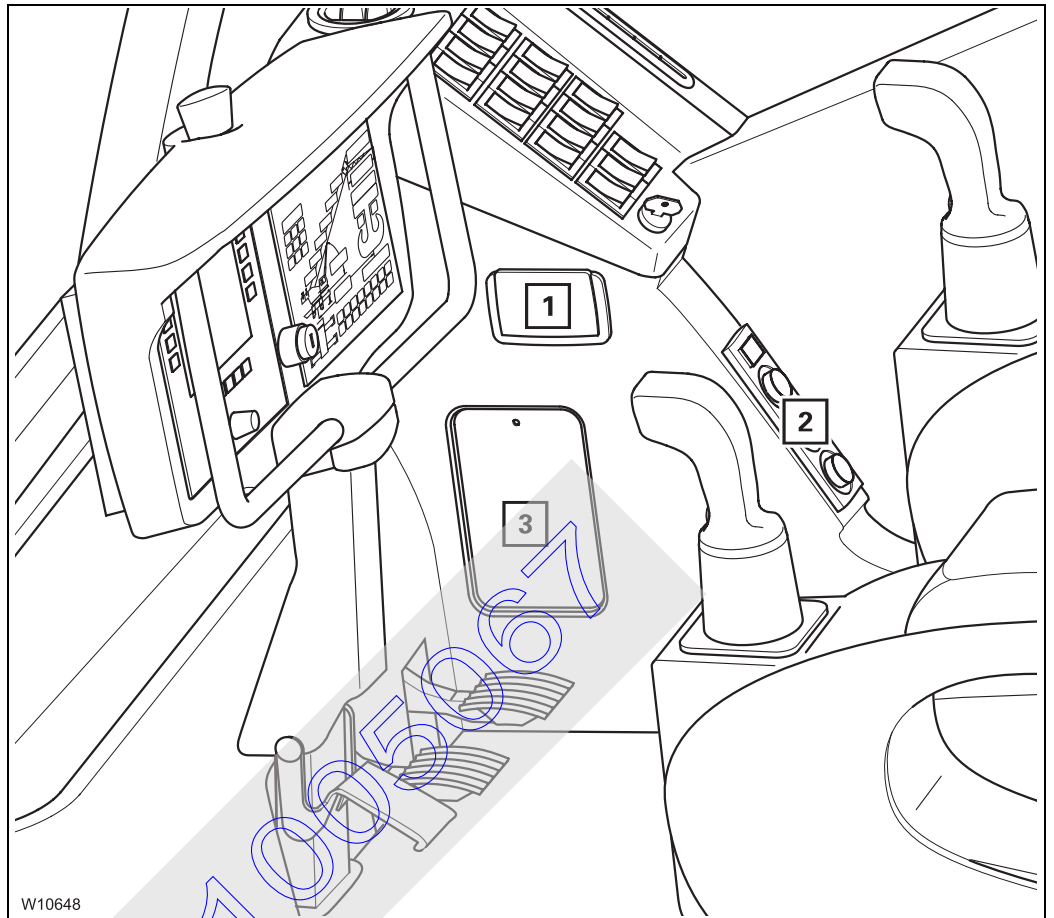

- 1 Ashtray
- 2 Standard heating system
- 3 Diagnostics (behind covering)

▮▮▮▮ p. 10 - 11

▮▮▮▮ p. 10 - 96



Top

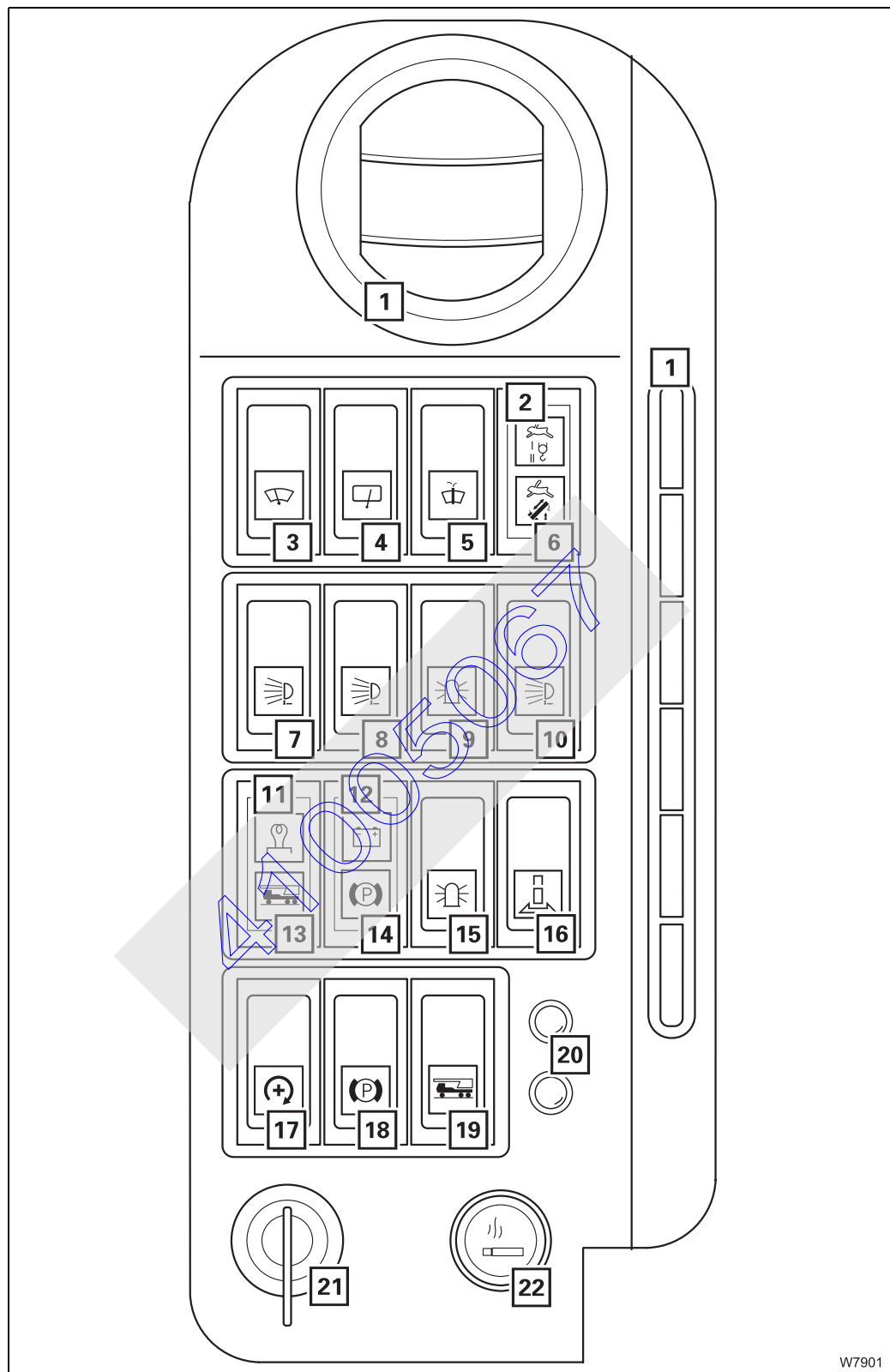

W7901

1	Air vents	▣▣▣▣ p. 12 - 124
2	High speed indicator lamp for the hoists	▣▣▣▣ p. 10 - 69
3	Front windscreen wiper on / off	▣▣▣▣ p. 10 - 91
4	Roof window wiper on / off	▣▣▣▣ p. 10 - 91
5	Windscreen washing system	▣▣▣▣ p. 10 - 91
6	High-speed indicator lamp for derricking gear / tele- scoping mechanism	▣▣▣▣ p. 10 - 73
7	Spotlight sockets on / off	▣▣▣▣ p. 10 - 89
8	Slewable spotlight on / off ¹⁾	▣▣▣▣ p. 10 - 90
9	Air traffic control light on / off ¹⁾	▣▣▣▣ p. 10 - 89
10	Directing the spotlights ¹⁾	▣▣▣▣ p. 10 - 90
11	Flame start system indicator lamp ¹⁾	▣▣▣▣ p. 10 - 51
12	Voltage warning lamp	▣▣▣▣ p. 10 - 89
13	Carrier ignition indicator lamp	▣▣▣▣ p. 10 - 51
14	Parking brake indicator lamp ¹⁾	▣▣▣▣ p. 10 - 103
15	Rotating beacon on / off ¹⁾	▣▣▣▣ p. 10 - 89
16	Houselock on / off ¹⁾	▣▣▣▣ p. 10 - 82
17	Setting the idling speed	▣▣▣▣ p. 10 - 51
18	Applying / releasing parking brake ¹⁾	▣▣▣▣ p. 10 - 103
19	Carrier ignition on / off	▣▣▣▣ p. 10 - 53
20	Soot particle filter indicator lamp – Version 1 ¹⁾ Version 2 ^{1), 2)}	▣▣▣▣ p. 10 - 52
21	Ignition lock	▣▣▣▣ p. 10 - 51
22	Cigarette lighter (24 volts)	

¹⁾ Additional equipment

²⁾ ▣▣▣▣ *Separate operating instructions*



Blank page

41005067

Standard heating system

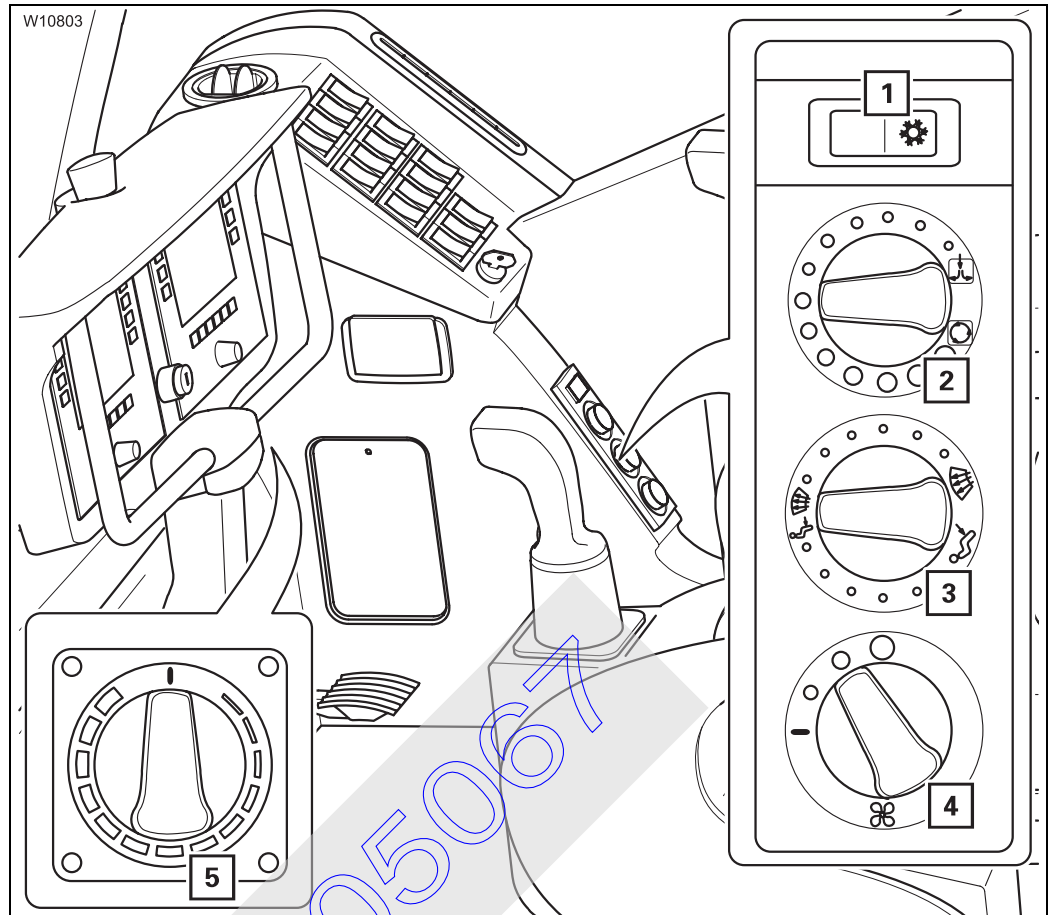

1 Air-conditioning system¹⁾

▣ p. 12 - 125

2 Setting fresh air / recirculated air / mixed air

▣ p. 12 - 123

3 Air distribution

▣ p. 12 - 124

4 Setting the fan

▣ p. 12 - 123

5 Setting the temperature

▣ p. 12 - 124

¹⁾ Additional equipment



Auxiliary water heater

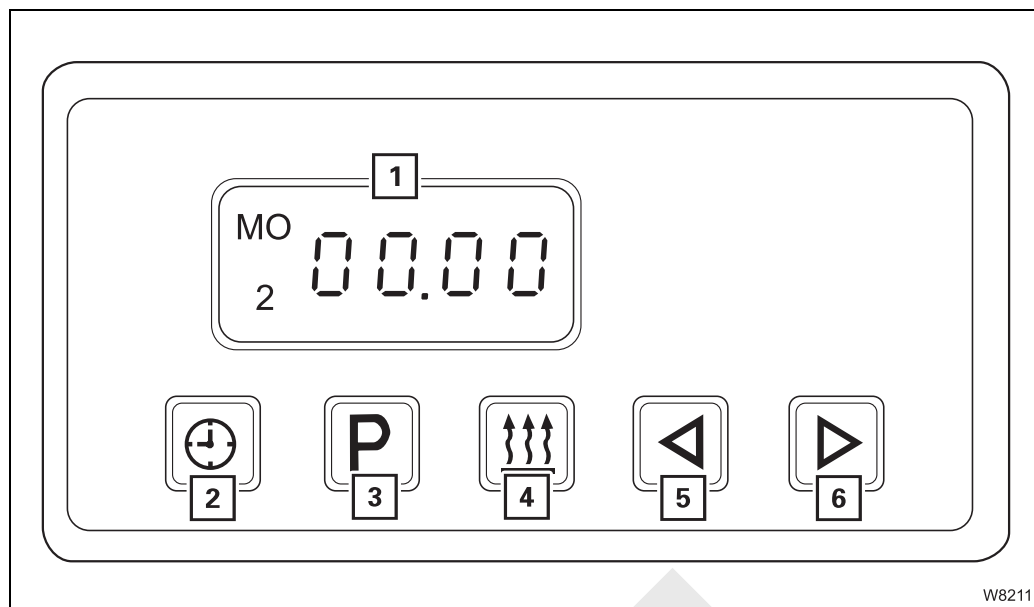

- | | |
|--------------------------------------|------------------|
| 1 Heating display | ▣▣▣▣ p. 12 - 129 |
| 2 Setting the day and time | ▣▣▣▣ p. 12 - 130 |
| 3 – Storing the heating start | ▣▣▣▣ p. 12 - 131 |
| – Switching heating start on / off | ▣▣▣▣ p. 12 - 132 |
| 4 – Switching on | ▣▣▣▣ p. 12 - 129 |
| – Switching off | ▣▣▣▣ p. 12 - 133 |
| 5 Input – | ▣▣▣▣ p. 12 - 130 |
| 6 Input + | ▣▣▣▣ p. 12 - 130 |

41005067

Auxiliary air heater

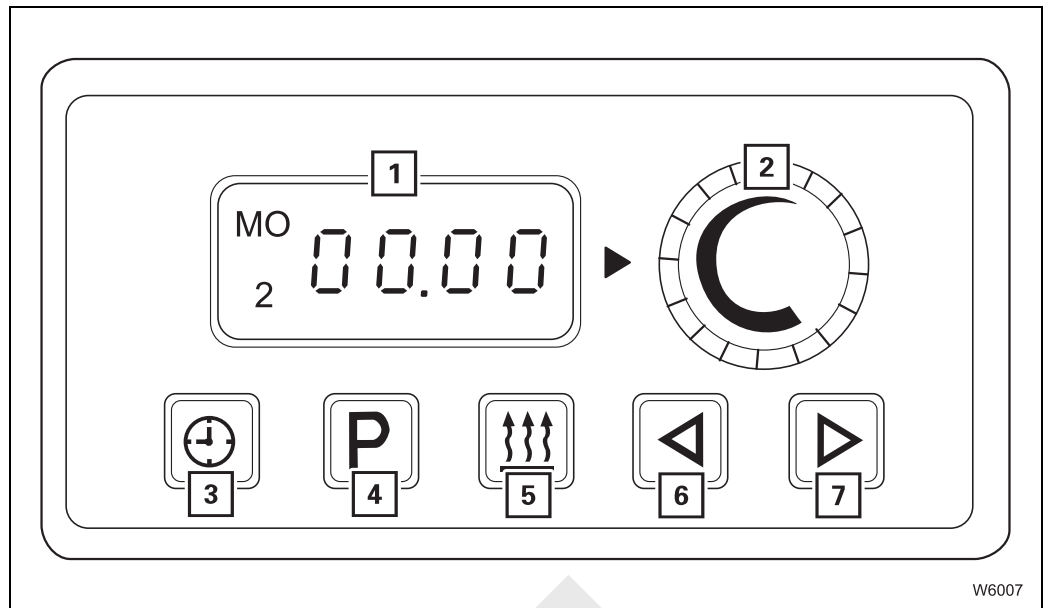

- | | |
|--------------------------------------|------------------|
| 1 Heating display | ▣▣▣▣ p. 12 - 134 |
| 2 Temperature | ▣▣▣▣ p. 12 - 135 |
| 3 Setting the time / day | ▣▣▣▣ p. 12 - 135 |
| 4 – Storing the heating start | ▣▣▣▣ p. 12 - 135 |
| – Switching heating start on / off | ▣▣▣▣ p. 12 - 135 |
| 5 – Switching on | ▣▣▣▣ p. 12 - 134 |
| – Switching off | ▣▣▣▣ p. 12 - 135 |
| 6 Input – | ▣▣▣▣ p. 12 - 135 |
| 7 Input + | ▣▣▣▣ p. 12 - 135 |

10.1.5

Control panels

Left

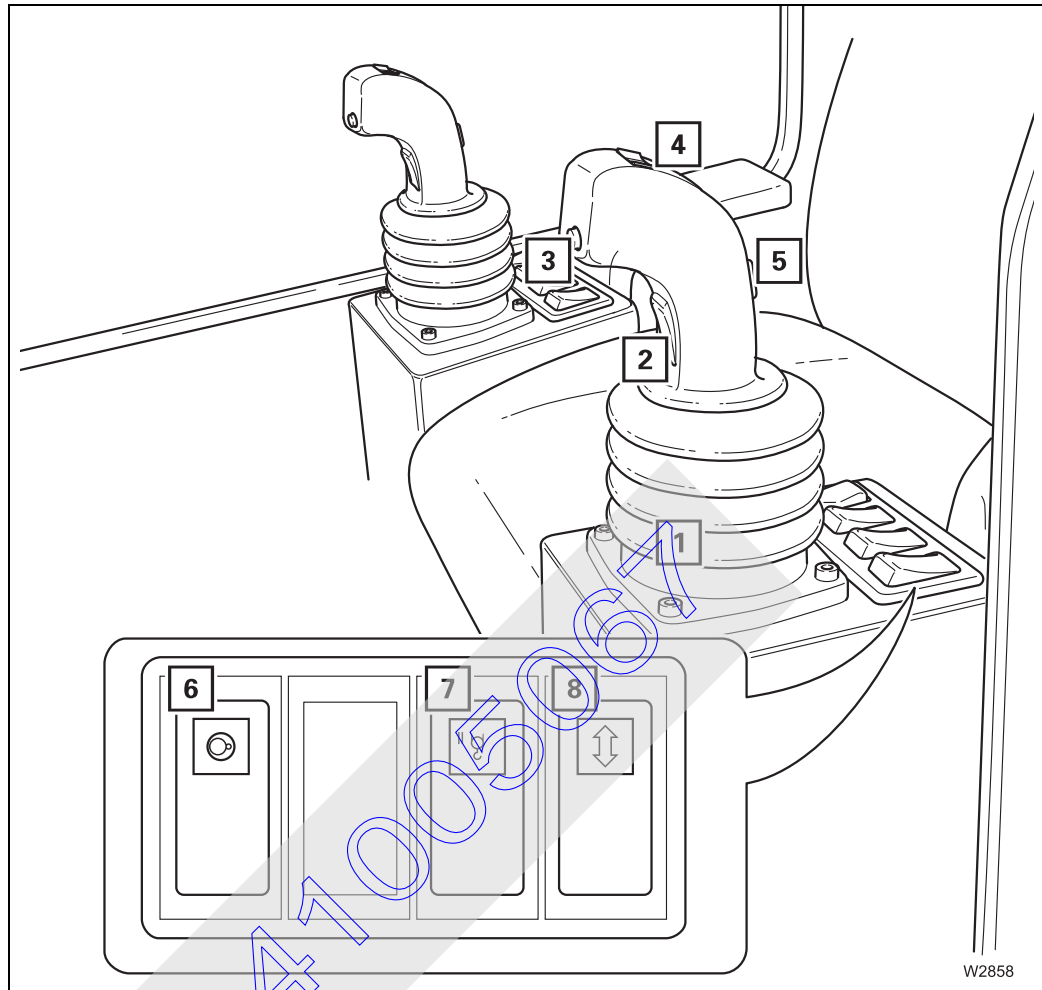

- | | |
|--|------------------|
| 1 Left-hand control lever (assignment according to design) | ▣▣▣▣ p. 10 - 16 |
| 2 Dead man's switch | ▣▣▣▣ p. 10 - 54 |
| 3 Horn button | |
| 4 Depending on which function is switched on, button for: | ▣▣▣▣ p. 10 - 73 |
| – Derricking gear / Telescoping mechanism high-speed mode on / off | ▣▣▣▣ p. 10 - 105 |
| – Steering with separate steering | |
| 5 Auxiliary hoist slewing indicator | ▣▣▣▣ p. 12 - 49 |
| 6 Slewing gear on / off | ▣▣▣▣ p. 10 - 71 |
| 7 Auxiliary hoist on / off ¹⁾ | ▣▣▣▣ p. 10 - 70 |
| 8 Inclining the crane cab ¹⁾ | ▣▣▣▣ p. 10 - 81 |

¹⁾ Additional equipment

Right

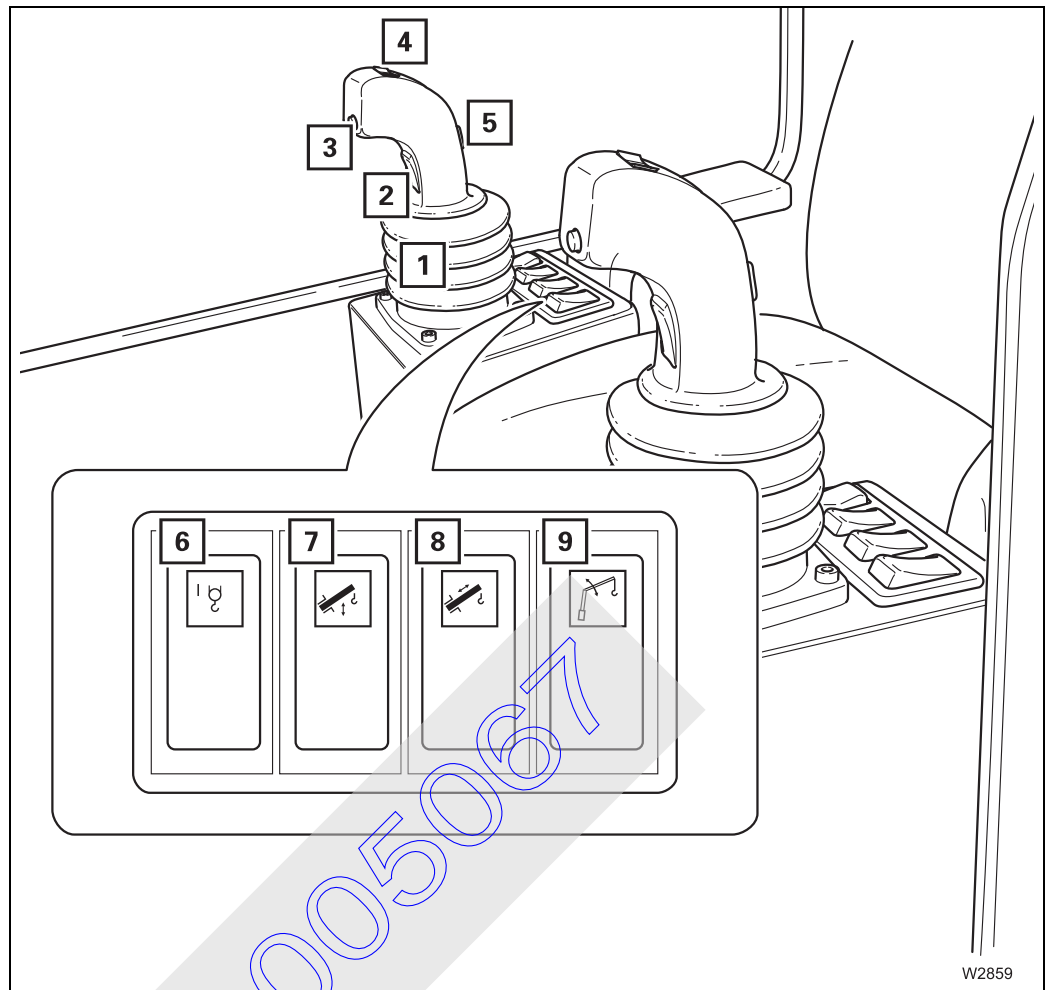

- 1 Right hand control lever (assignment according to design) ▶▶▶▶▶ p. 10 - 16
- 2 Dead man's switch ▶▶▶▶▶ p. 10 - 54
- 3 Horn button
- 4 Depending on which function is switched on, button for:
 - Hoist high-speed mode on / off ▶▶▶▶▶ p. 10 - 69
 - Steering in normal steering mode ▶▶▶▶▶ p. 10 - 105
- 5 Main hoist slewing indicator ▶▶▶▶▶ p. 12 - 46
- 6 Main hoist on / off ▶▶▶▶▶ p. 10 - 68
- 7 Derricking gear on / off ▶▶▶▶▶ p. 10 - 73
- 8 Telescoping mechanism on / off ▶▶▶▶▶ p. 10 - 74
- 9 Derrick lattice extension on / off^{1), 2)}

1) Additional equipment

2) ▶▶▶▶▶ *Operating Instructions Lattice Extension*

10.1.6 Control lever assignment

The truck crane can be equipped with two different control lever assignments. The current assignment of the control levers is indicated by symbols on the control levers.

Version 1

With version 1 the left-hand control lever is assigned the function *Telescoping*.

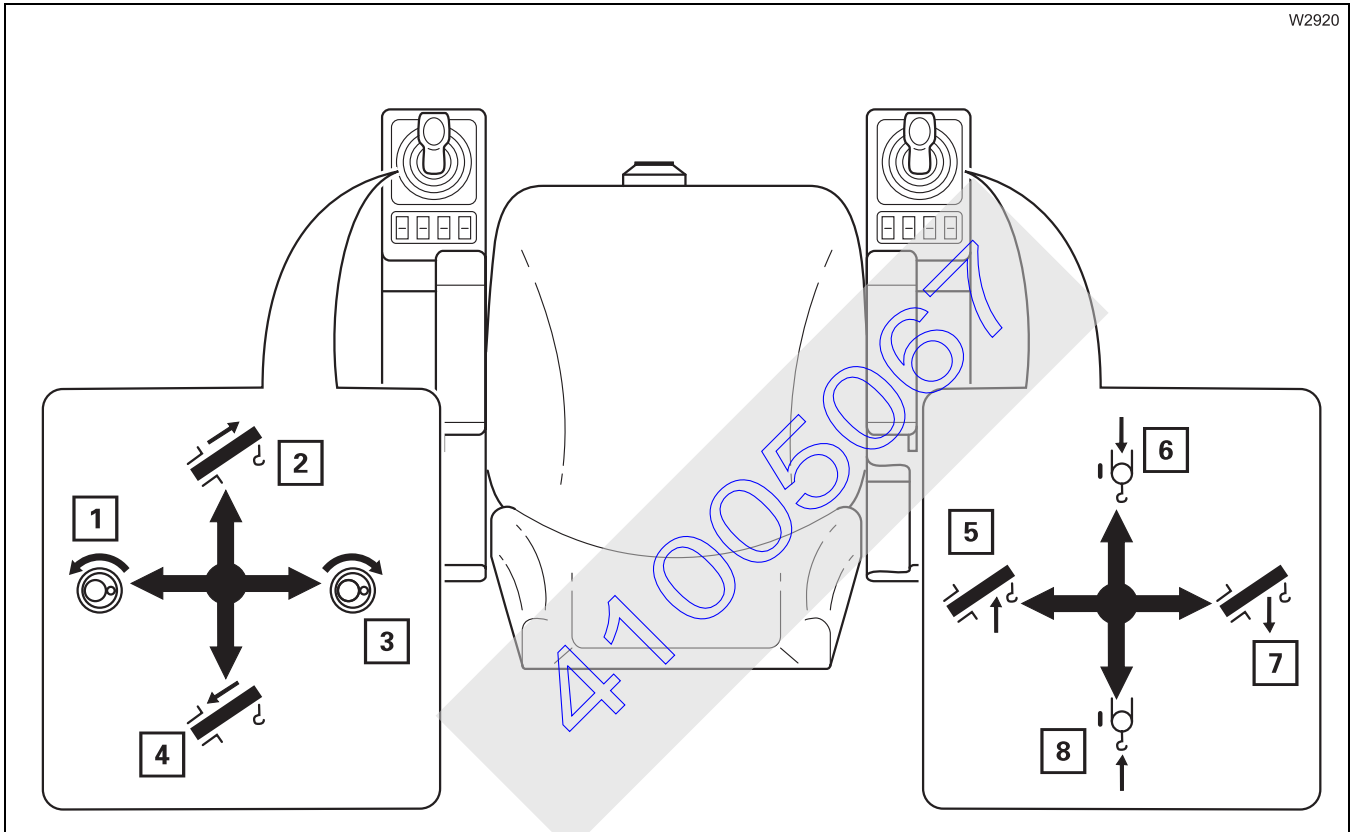

Left-hand control lever

- 1 Slewing to the left
- 3 Slewing to the right
- 2 Extending
- 4 Retracting

Right-hand control lever

- 5 Raising
- 7 Lowering
- 6 Lowering the main hoist
- 8 Raising the main hoist

Version 2

With version 2 the right-hand control lever is assigned the function *Telescoping*.

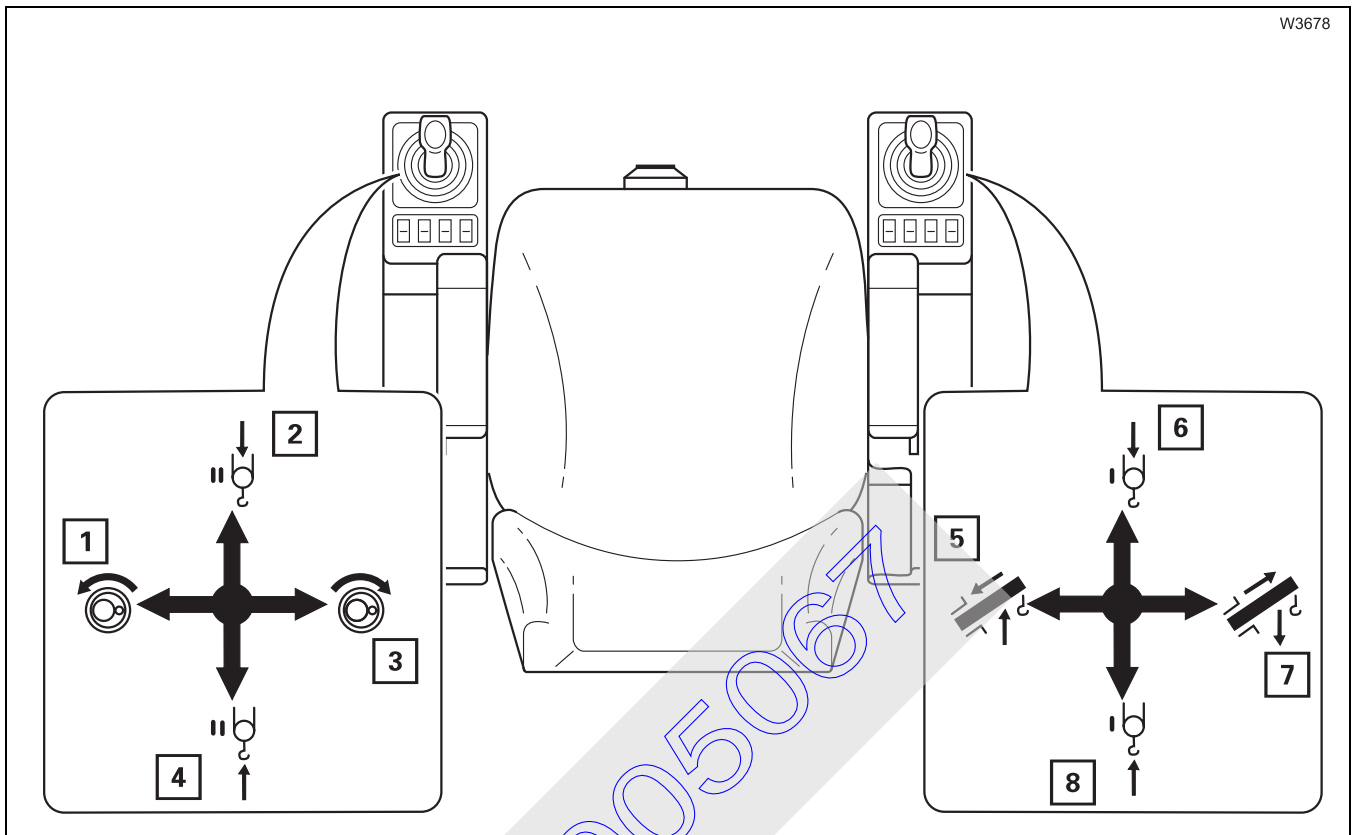

Left-hand control lever

- 1 Slewing to the left
- 3 Slewing to the right
- 2 Lowering the auxiliary hoist¹⁾
- 4 Raising the auxiliary hoist¹⁾

Right-hand control lever

- 5 Raising / retracting²⁾
- 7 Lowering / extending²⁾
- 6 Lowering the main hoist
- 8 Raising the main hoist

¹⁾ Additional equipment

²⁾ Derricking the lattice extension;  *Operating Instructions Lattice Extension*

10.1.7

ECOS control unit

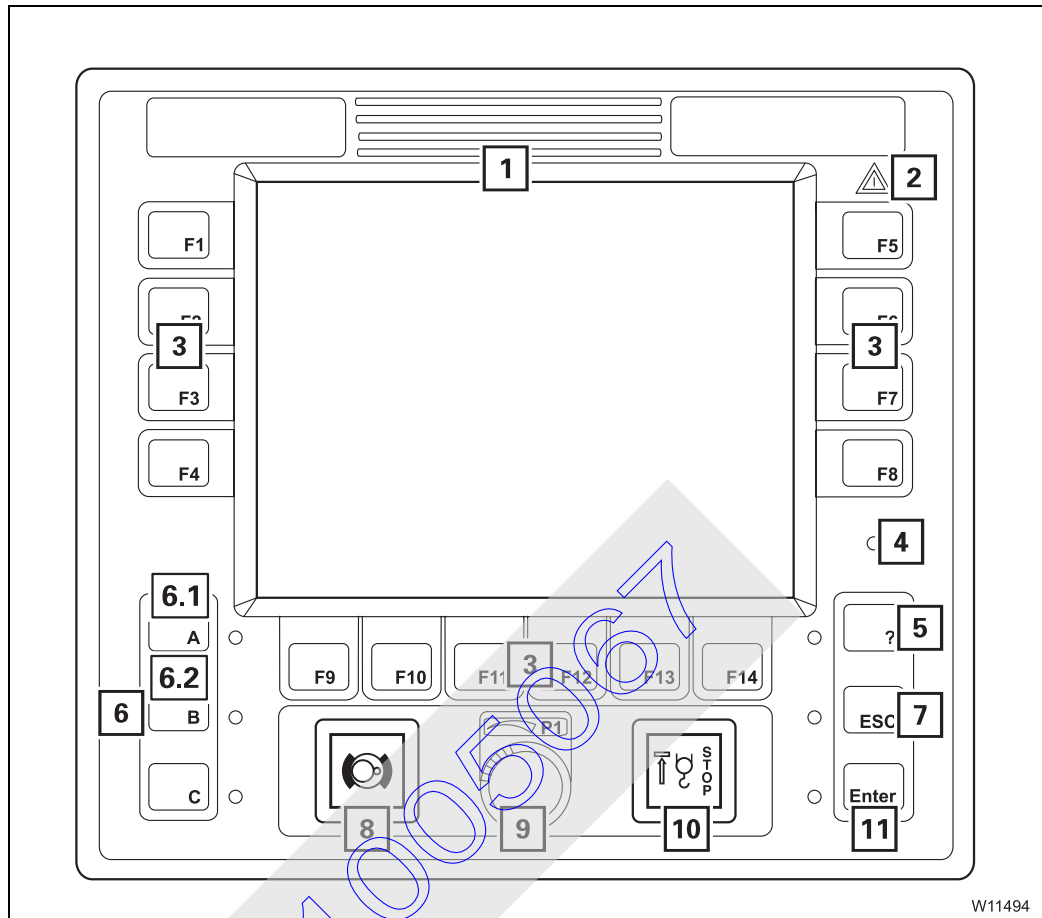

1	ECOS display	▣▣▣▣▶ p. 10 - 57
	Main menu overview	▣▣▣▣▶ p. 10 - 20
2	Error / warning message	▣▣▣▣▶ p. 10 - 55
3	Buttons F1 to F14	▣▣▣▣▶ p. 10 - 55
4	Sensor for brightness	▣▣▣▣▶ p. 10 - 57
5	Opening the error submenu	▣▣▣▣▶ p. 10 - 55
	Submenu overview	▣▣▣▣▶ p. 10 - 36
6	Entering the keycode	▣▣▣▣▶ p. 10 - 56
6.1	Opening the warning submenu	▣▣▣▣▶ p. 10 - 55
	Submenu overview (superstructure)	▣▣▣▣▶ p. 10 - 33
6.2	Opening the warning submenu	▣▣▣▣▶ p. 10 - 56
	Submenu overview (carrier)	▣▣▣▣▶ p. 10 - 33
7	Exiting the submenu / input mode	▣▣▣▣▶ p. 10 - 56
8	Slewing gear brake engaged / released	▣▣▣▣▶ p. 10 - 71
9	Entering values	▣▣▣▣▶ p. 10 - 56
10	Warning lamp for lifting limit switch shutdown	▣▣▣▣▶ p. 10 - 69
11	Confirming an entry	▣▣▣▣▶ p. 10 - 56



Various menus are shown on the *ECOS* display.

The menus are operated using buttons F1 to F14. The individual buttons have a different function in each menu. The functions of the buttons in the displayed menu correspond to the symbols next to or above the buttons;

▣▣▣▣▶ p. 10 - 55.

10.1.8 ECOS display – main menu

The main menu displays symbols for further submenus and symbols for current displays.

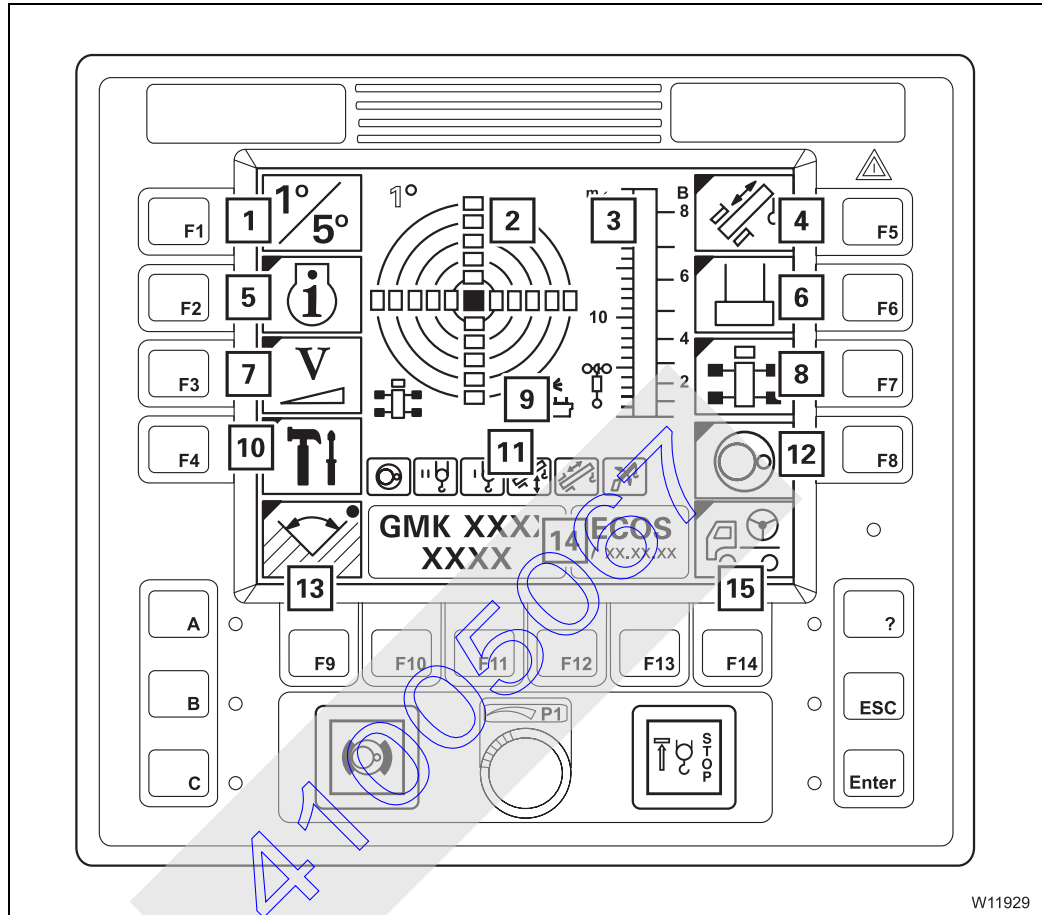

W11929

1	Switching over the measuring range	▶▶▶▶▶ p. 10 - 63
2	Display of current inclination	▶▶▶▶▶ p. 10 - 63
3	Anemometer display ¹⁾	▶▶▶▶▶ p. 10 - 64
4	Telescoping submenu	▶▶▶▶▶ p. 10 - 26
5	Monitoring submenu	▶▶▶▶▶ p. 10 - 29
6	Counterweight submenu ¹⁾	▶▶▶▶▶ p. 10 - 22
7	Power unit speeds submenu	▶▶▶▶▶ p. 10 - 28
8	Outriggers submenu	▶▶▶▶▶ p. 10 - 24
9	Remote control display ^{1), 3)}	
10	Settings submenu	▶▶▶▶▶ p. 10 - 30
11	Power units display	
	Slewing gear	▶▶▶▶▶ p. 10 - 71
	Main hoist	▶▶▶▶▶ p. 10 - 68
	Auxiliary hoist	▶▶▶▶▶ p. 10 - 70
	Derricking gear	▶▶▶▶▶ p. 10 - 73
	Telescoping mechanism	▶▶▶▶▶ p. 10 - 74
	Derricking the lattice extension ^{1), 2)}	
12	Slewing gear / Houselock submenu ¹⁾	▶▶▶▶▶ p. 10 - 23
13	Working range limitation submenu ¹⁾	▶▶▶▶▶ p. 10 - 36
14	Serial number and program version displays	▶▶▶▶▶ p. 10 - 57
15	Driving submenu ¹⁾	▶▶▶▶▶ p. 10 - 38

¹⁾ Additional equipment

²⁾ ▶▶▶▶▶ *Operating Instructions Lattice Extension*

³⁾ ▶▶▶▶▶ *Separate operating instructions*

10.1.9

ECOS display – submenus

Counterweight submenu

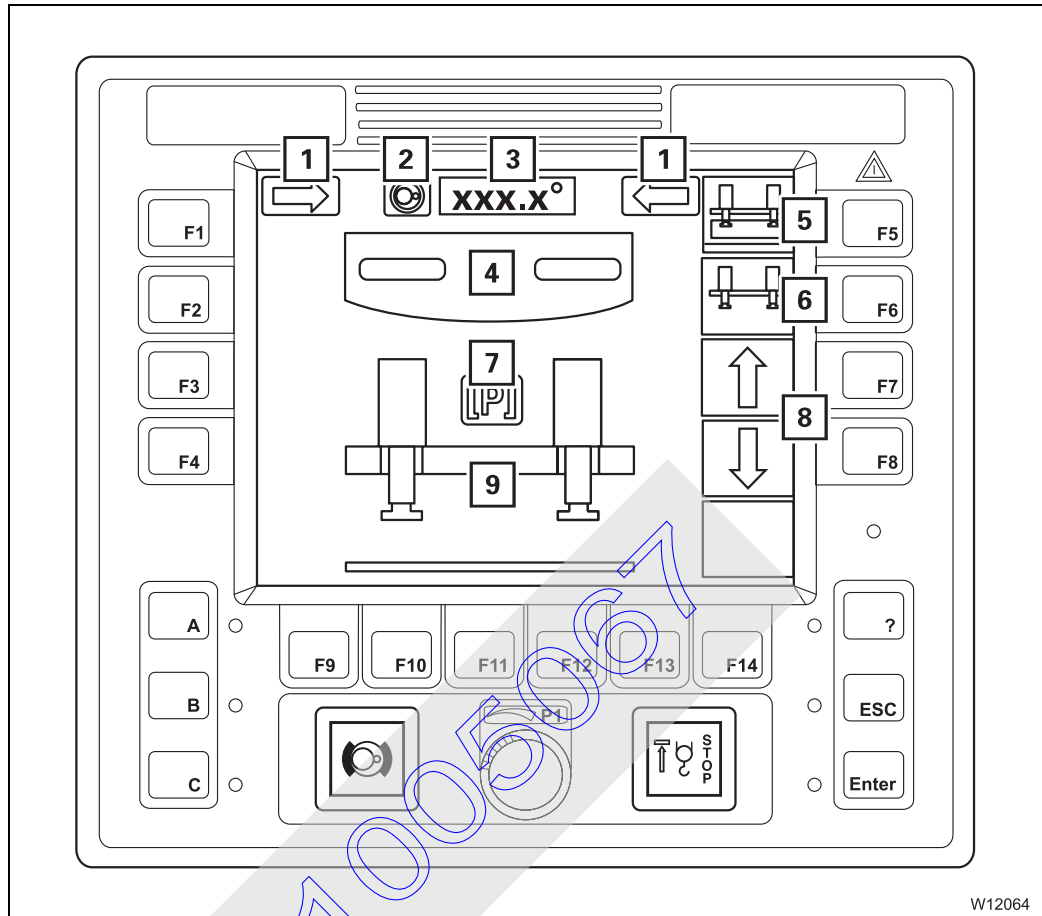

W12064

- | | |
|--|-----------------|
| 1 Display of slewing direction for automatic mode | ▣▣▣▣ p. 10 - 65 |
| 2 Slewing gear display | ▣▣▣▣ p. 10 - 68 |
| 3 Current slewing angle display | ▣▣▣▣ p. 10 - 68 |
| 4 Rigging position display | ▣▣▣▣ p. 10 - 65 |
| 5 Rigging automatic mode | ▣▣▣▣ p. 10 - 66 |
| 6 Unrigging automatic mode | ▣▣▣▣ p. 10 - 66 |
| 7 Pre-tensioning pressure display | ▣▣▣▣ p. 10 - 67 |
| 8 Extending / Retracting the lifting cylinders | ▣▣▣▣ p. 10 - 67 |
| 9 Lifting cylinder position display | ▣▣▣▣ p. 10 - 67 |

**Slewing gear /
Houselock sub-
menu**

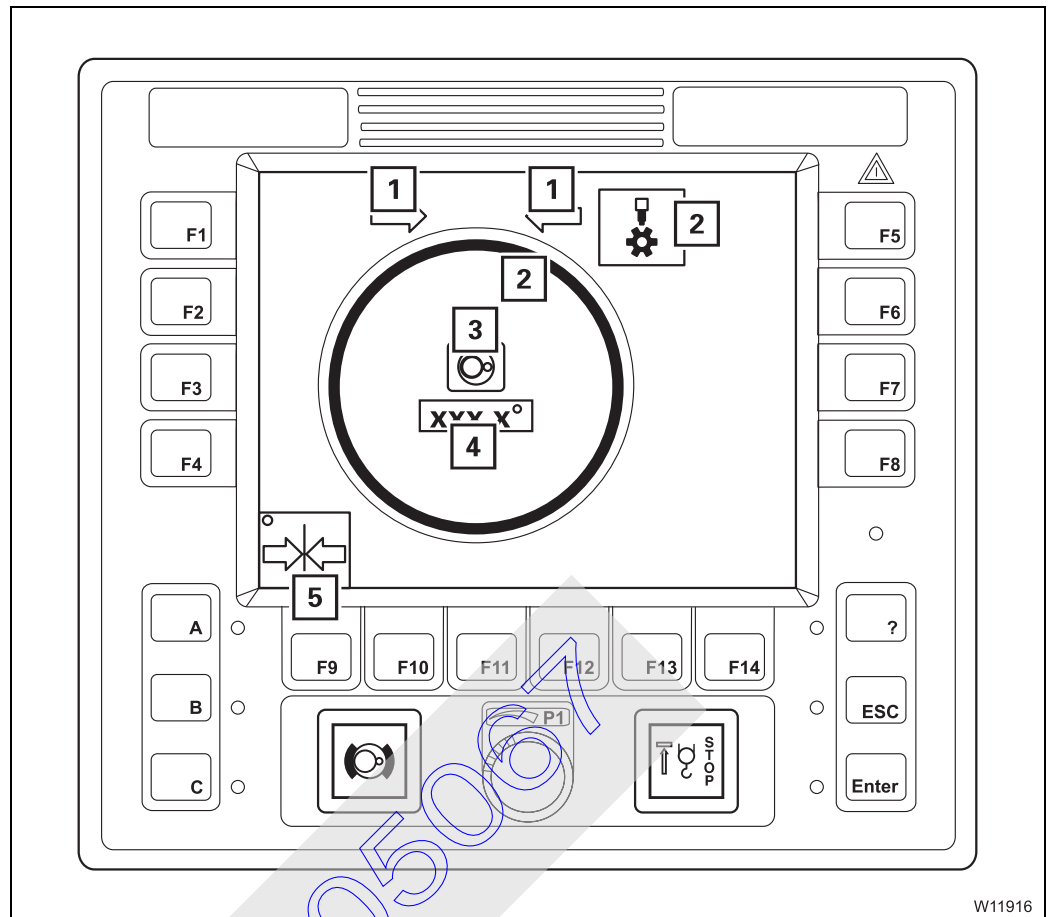

W11916

- | | | |
|---|---|-----------------|
| 1 | Display of slewing direction to 0° / 180° ¹⁾ | ▣▣▣▣ p. 10 - 72 |
| 2 | Locking status displays ¹⁾ | ▣▣▣▣ p. 10 - 82 |
| 3 | Slewing gear display | ▣▣▣▣ p. 10 - 72 |
| 4 | Current slewing angle display | ▣▣▣▣ p. 10 - 72 |
| 5 | Stop at 0° / 180° ¹⁾ | ▣▣▣▣ p. 10 - 72 |

¹⁾ Additional equipment



**Outriggers
submenu**

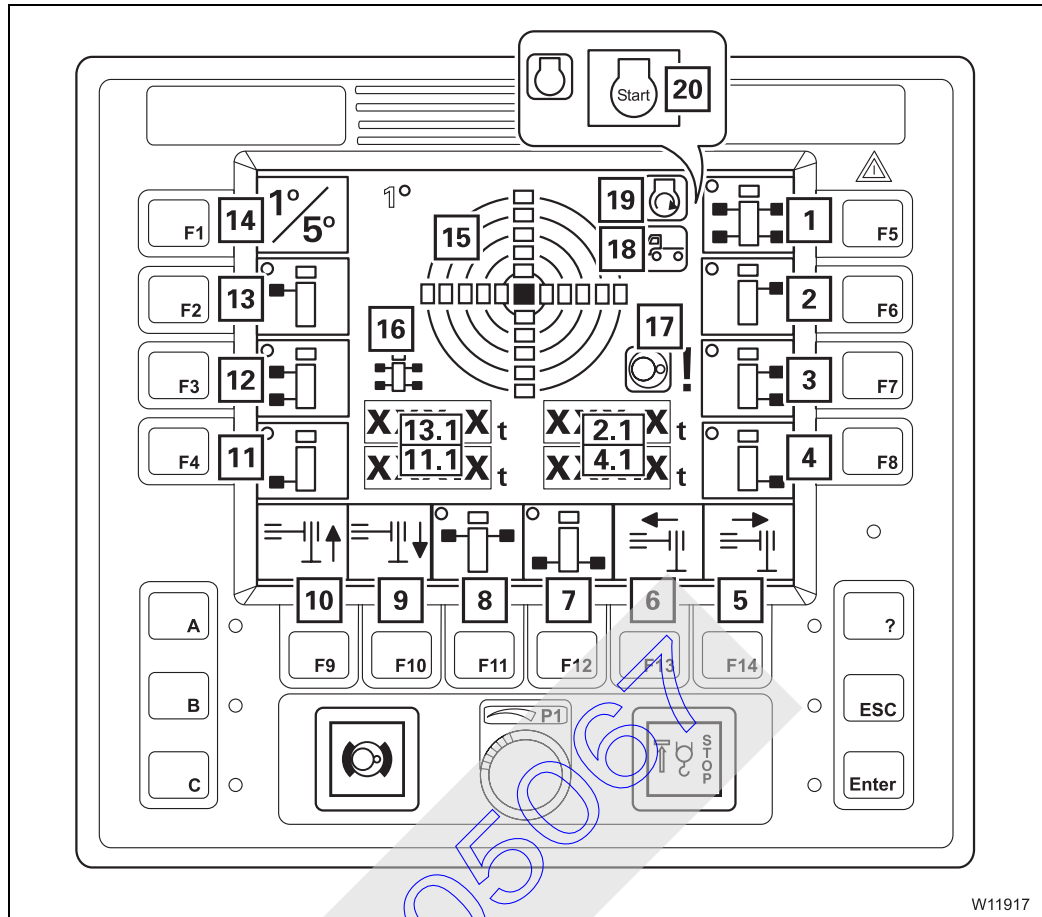

1	All supporting cylinders	▶▶▶▶▶ p. 10 - 60
2	Front right-hand outrigger	▶▶▶▶▶ p. 10 - 60
2.1	Front right-hand outrigger pressure display ¹⁾	▶▶▶▶▶ p. 10 - 64
3	Right-hand support cylinder	▶▶▶▶▶ p. 10 - 60
4	Rear right-hand outrigger	▶▶▶▶▶ p. 10 - 60
4.1	Rear right-hand outrigger pressure display ¹⁾	▶▶▶▶▶ p. 10 - 64
5	Extending the outrigger beams	▶▶▶▶▶ p. 10 - 60
6	Retracting the outrigger beams	▶▶▶▶▶ p. 10 - 60
7	Rear supporting cylinder	▶▶▶▶▶ p. 10 - 60
8	Front supporting cylinder	▶▶▶▶▶ p. 10 - 60
9	Extending the supporting cylinders	▶▶▶▶▶ p. 10 - 60
10	Retracting the supporting cylinders	▶▶▶▶▶ p. 10 - 60
11	Rear left-hand outrigger	▶▶▶▶▶ p. 10 - 60
11.1	Rear left-hand outrigger pressure display ¹⁾	▶▶▶▶▶ p. 10 - 64
12	Left-hand supporting cylinder	▶▶▶▶▶ p. 10 - 60
13	Front left-hand outrigger	▶▶▶▶▶ p. 10 - 60
13.1	Front left-hand outrigger pressure display ¹⁾	▶▶▶▶▶ p. 10 - 64
14	Switching over the measuring range	▶▶▶▶▶ p. 10 - 63
15	Display of current inclination	▶▶▶▶▶ p. 10 - 63
16	Direction of inclination display	▶▶▶▶▶ p. 10 - 63
17	Slewing gear / movements locked display	▶▶▶▶▶ p. 10 - 59
18	Carrier ignition display	▶▶▶▶▶ p. 10 - 53
19	Display for engine for driving on / off	▶▶▶▶▶ p. 10 - 53
20	Start engine for driving	▶▶▶▶▶ p. 10 - 53

¹⁾ Additional equipment



Telescoping submenu

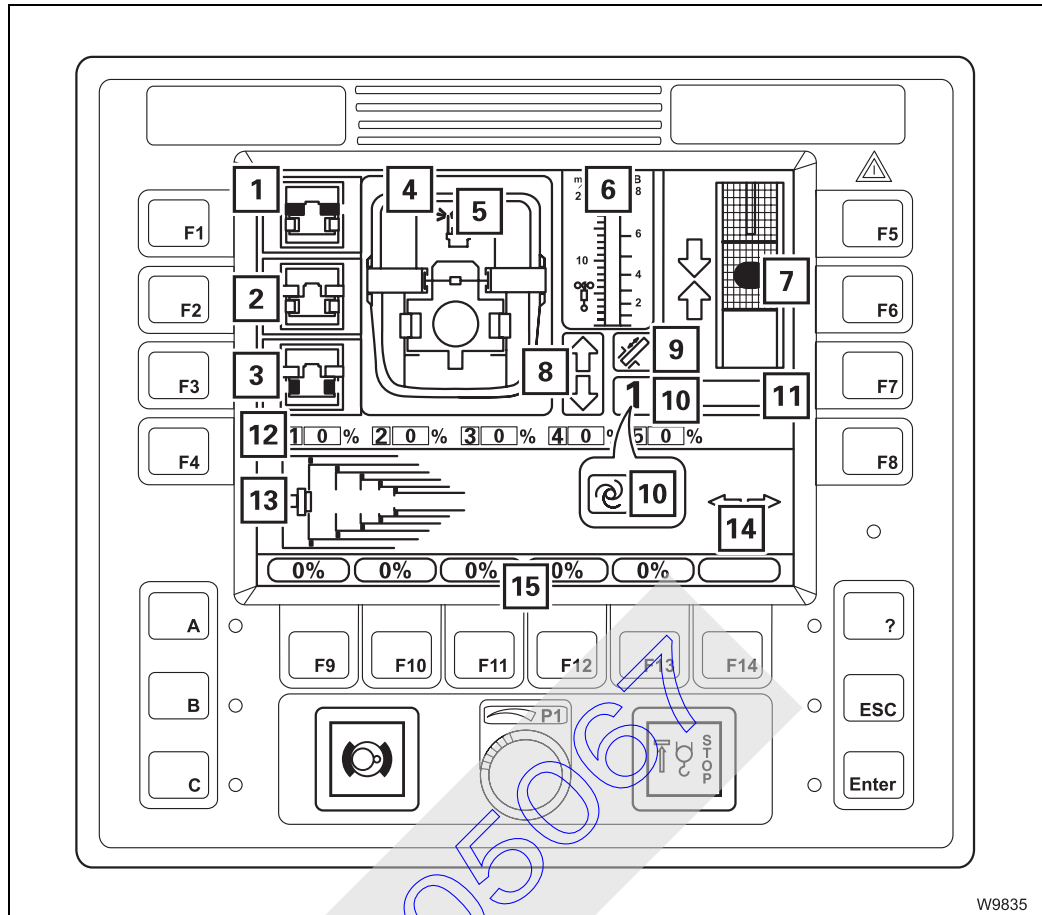

1	Select Unlock telescopic section	▣▣▣▣ p. 10 - 77
2	Select Lock	▣▣▣▣ p. 10 - 77
3	Select Unlock telescoping cylinder	▣▣▣▣ p. 10 - 76
4	Locking status display	▣▣▣▣ p. 10 - 76
5	Remote control display ¹⁾	
6	Anemometer display	▣▣▣▣ p. 10 - 64
7	Locking point display	▣▣▣▣ p. 10 - 78
8	Display for releasing telescoping	▣▣▣▣ p. 10 - 78
9	Display for telescoping mechanism on / off	▣▣▣▣ p. 10 - 75
10	– Display of telescoping cylinder in the telescopic section	▣▣▣▣ p. 10 - 75
	– Teleautomation on / off display	▣▣▣▣ p. 10 - 79
11	Telescoping cylinder length display	▣▣▣▣ p. 10 - 77
12	Current telescoping display	▣▣▣▣ p. 10 - 75
13	Telescope diagram display	▣▣▣▣ p. 10 - 76
14	Teleautomation direction display	▣▣▣▣ p. 10 - 79
15	Entering the nominal value for teleautomation	▣▣▣▣ p. 10 - 78

¹⁾ ▣▣▣▣ *Separate operating instructions*



Power unit speeds submenu

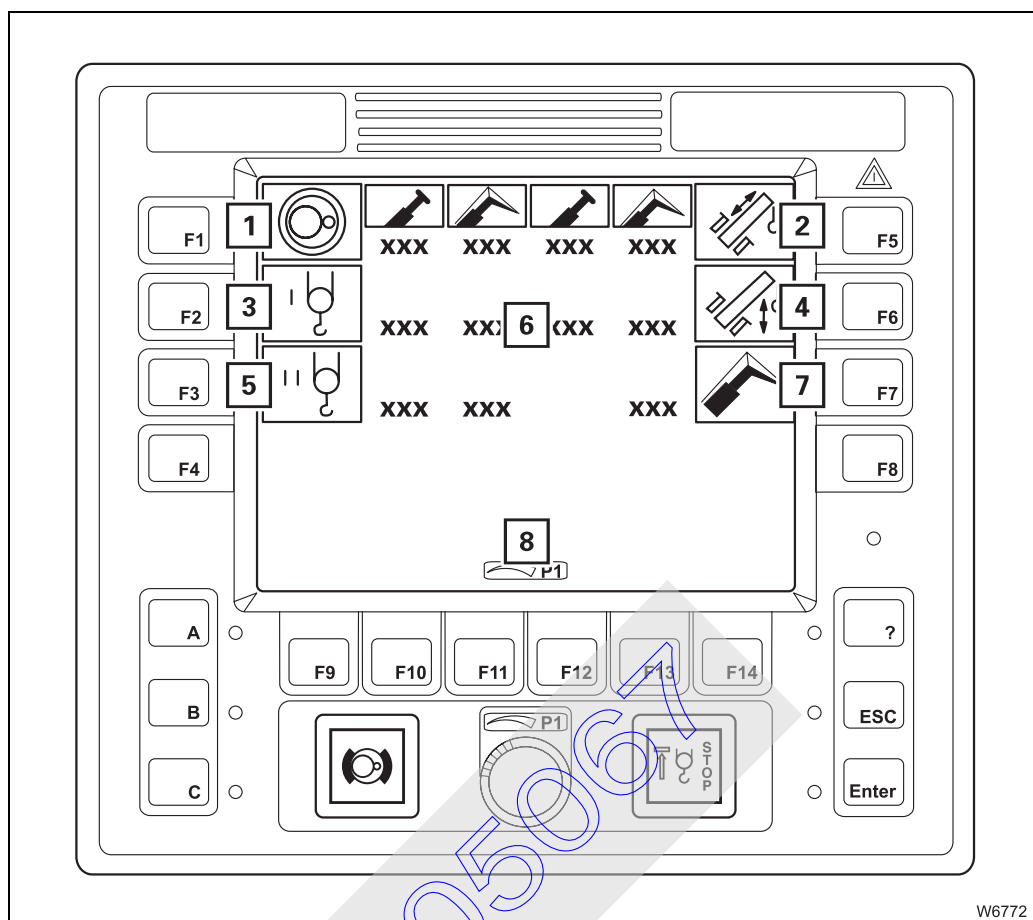

W6772

- | | | |
|---|--|-----------------|
| 1 | Enter slewing gear speed | ▣▣▣▣ p. 12 - 96 |
| 2 | Enter telescoping mechanism speed | ▣▣▣▣ p. 12 - 96 |
| 3 | Enter main hoist speed | ▣▣▣▣ p. 12 - 96 |
| 4 | Enter derricking gear speed | ▣▣▣▣ p. 12 - 96 |
| 5 | Enter auxiliary hoist speed | ▣▣▣▣ p. 12 - 96 |
| 6 | Displays of entered speed | ▣▣▣▣ p. 12 - 96 |
| 7 | Enter speed for derricking gear of lattice extension ¹⁾ | |
| 8 | Display for input mode on | |

¹⁾ Additional equipment

Monitoring submenu

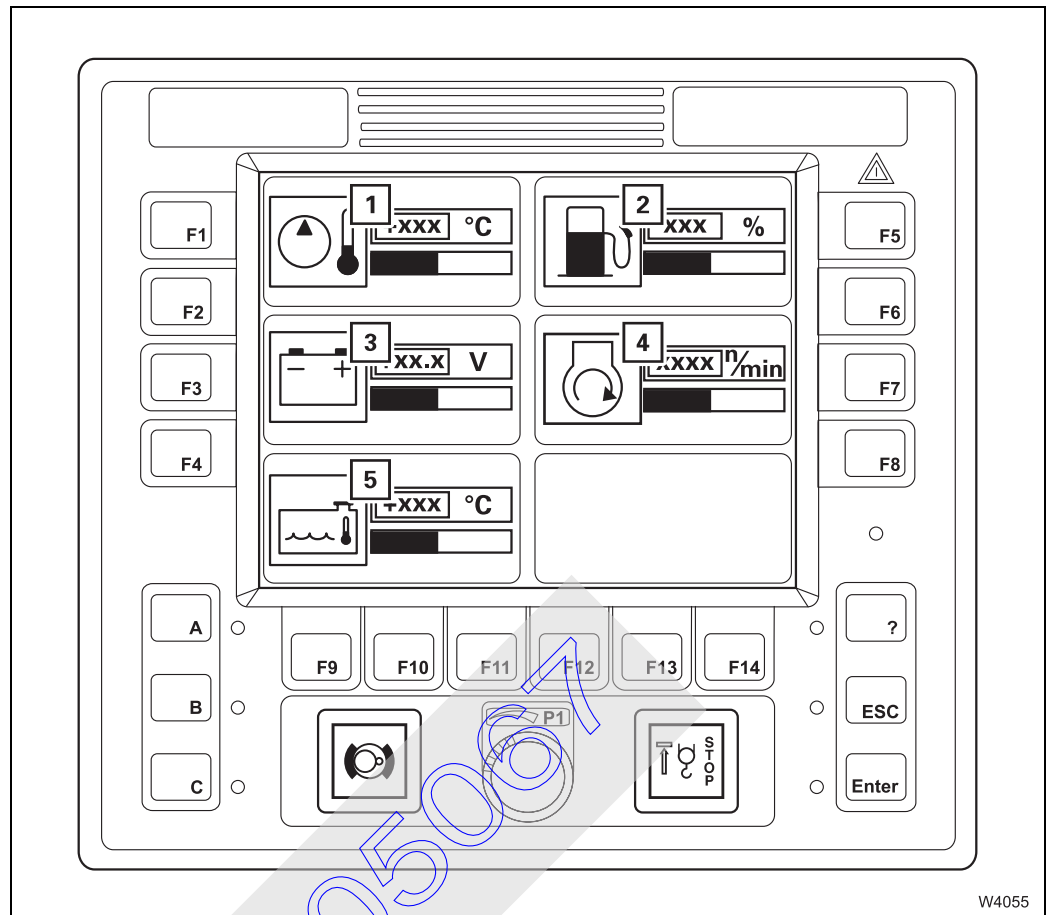

W4055

- | | |
|--|-----------------|
| 1 Hydraulic oil temperature display | ▣▣▣▣ p. 11 - 15 |
| 2 Fuel level display | ▣▣▣▣ p. 11 - 15 |
| 3 Voltage monitoring display | ▣▣▣▣ p. 11 - 15 |
| 4 Engine speed display | ▣▣▣▣ p. 11 - 15 |
| 5 Coolant temperature display | ▣▣▣▣ p. 11 - 15 |



Settings submenu

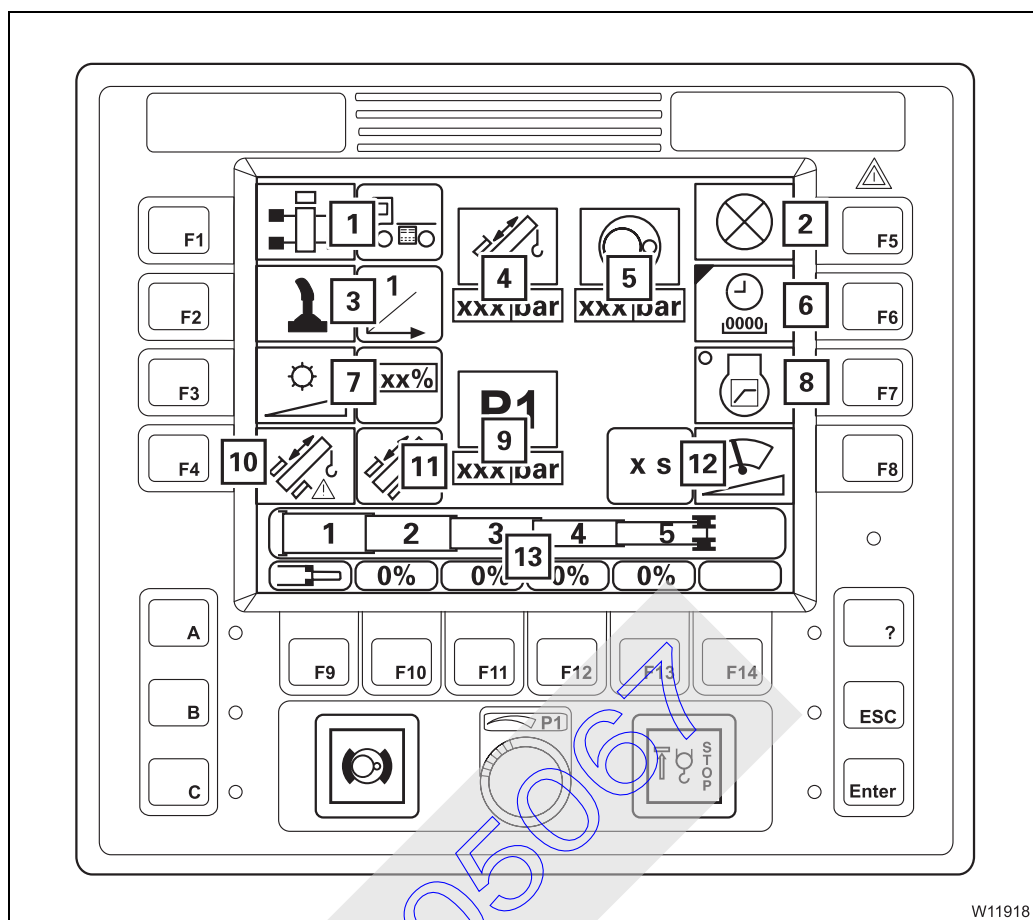

1	Outrigger control units on / off¹⁾	▣▣▣▣ p. 10 - 60
2	Lamp test	▣▣▣▣ p. 11 - 9
3	Telescoping cylinder pressure display	▣▣▣▣ p. 10 - 81
4	Slewing gear hydraulic circuit pressure display	▣▣▣▣ p. 10 - 81
5	Setting the characteristic curve for the control levers	▣▣▣▣ p. 12 - 98
6	Operating hours submenu	▣▣▣▣ p. 10 - 32
7	Set brightness of display	▣▣▣▣ p. 11 - 11
8	Critical load control on / off	▣▣▣▣ p. 10 - 81
9	Hydraulic circuit pressure display	▣▣▣▣ p. 10 - 81
10	Telescoping emergency program access	▣▣▣▣ p. 10 - 79
11	Current telescoping mechanism status display	▣▣▣▣ p. 10 - 80
12	Adjusting the wiper stroke interval	▣▣▣▣ p. 10 - 91
13	Entering the current telescoping	▣▣▣▣ p. 15 - 49

¹⁾ Additional equipment



41005067

Operating hours submenu

Description of the displays;  *Displaying the operating hours, p. 12 - 101.*

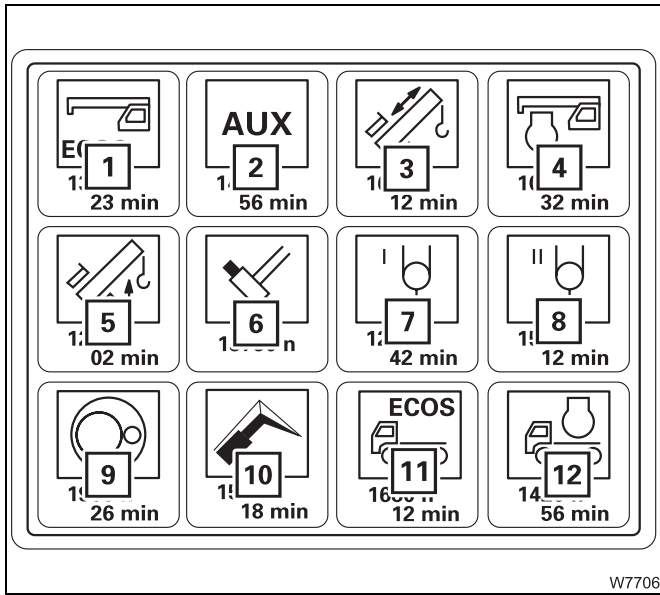

W7706

- 1 ECOS – superstructure
- 2 Auxiliary drive gears
- 3 Telescoping mechanism
- 4 Engine for crane operation
- 5 Derricking gear
- 6 Locking system
- 7 Main hoist
- 8 Auxiliary hoist¹⁾
- 9 Slewing gear
- 10 Lattice extension¹⁾
- 11 ECOS – carrier
- 12 Engine for driving

¹⁾ Additional equipment

41005061

Warning submenu Description of the displays;  *Warning submenu*, p. 12 - 102.

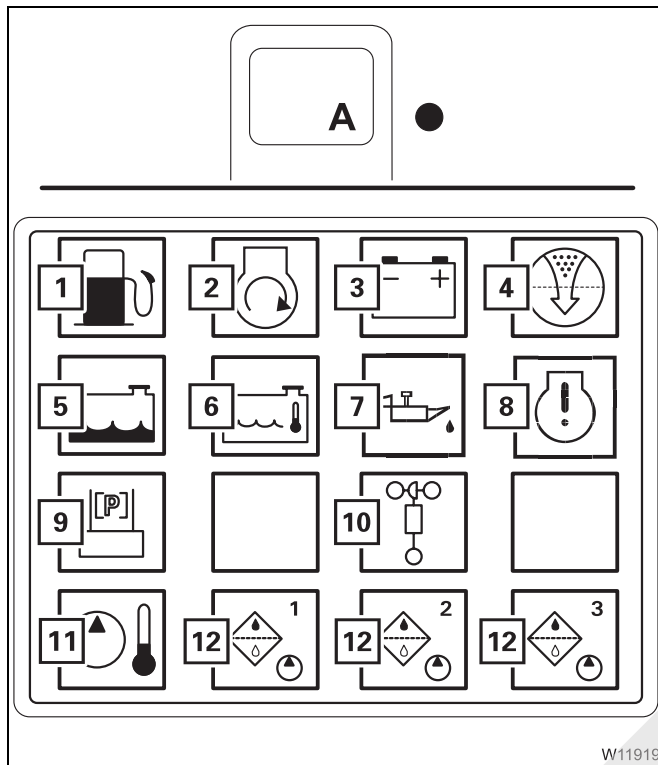

For the superstructure

- 1 Refuelling
- 2 Air intake inhibitor closed¹⁾
- 3 Voltage indicator lamp
- 4 Replacing the air filter
- 5 Coolant level too low
- 6 Coolant too hot
- 7 Oil pressure too low
- 8 Engine electronic system
- 9 Pre-tensioning the counterweight
- 10 Anemometer not connected
- 11 Hydraulic oil too hot
- 12 Replacing the hydraulic oil filter

¹⁾ Additional equipment

W11919

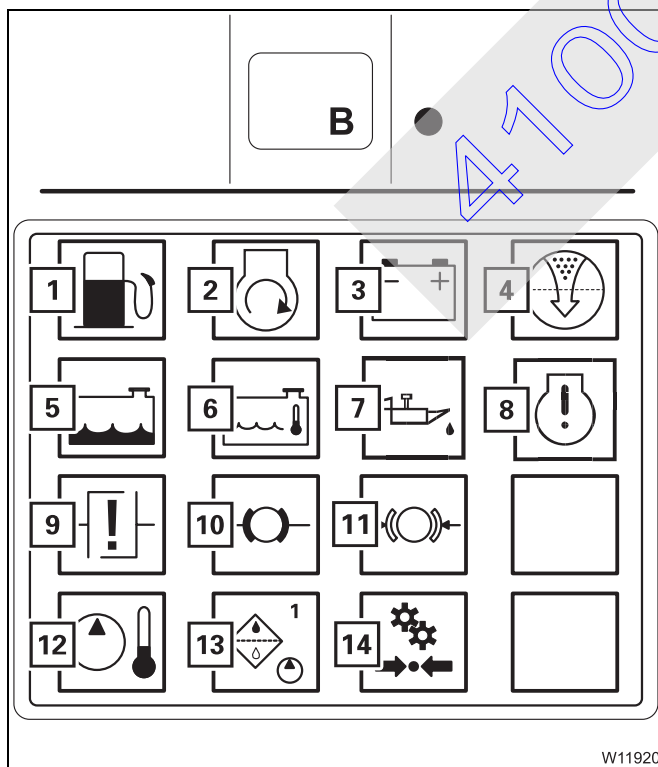

For the carrier

- 1 Refuelling
- 2 Air intake inhibitor closed¹⁾
- 3 Voltage indicator lamp
- 4 Replacing the air filter
- 5 Coolant level too low
- 6 Coolant too hot
- 7 Oil pressure too low
- 8 Engine electronic system
- 9 Clutch overloaded
- 10 Supply pressure in the brake circuit too low
- 11 Prompt to brake
- 12 Hydraulic oil too hot
- 13 Replacing the hydraulic oil filter
- 14 Supply pressure in secondary consumers too low

¹⁾ Additional equipment

W11920

Blank page

41005067

Error submenu

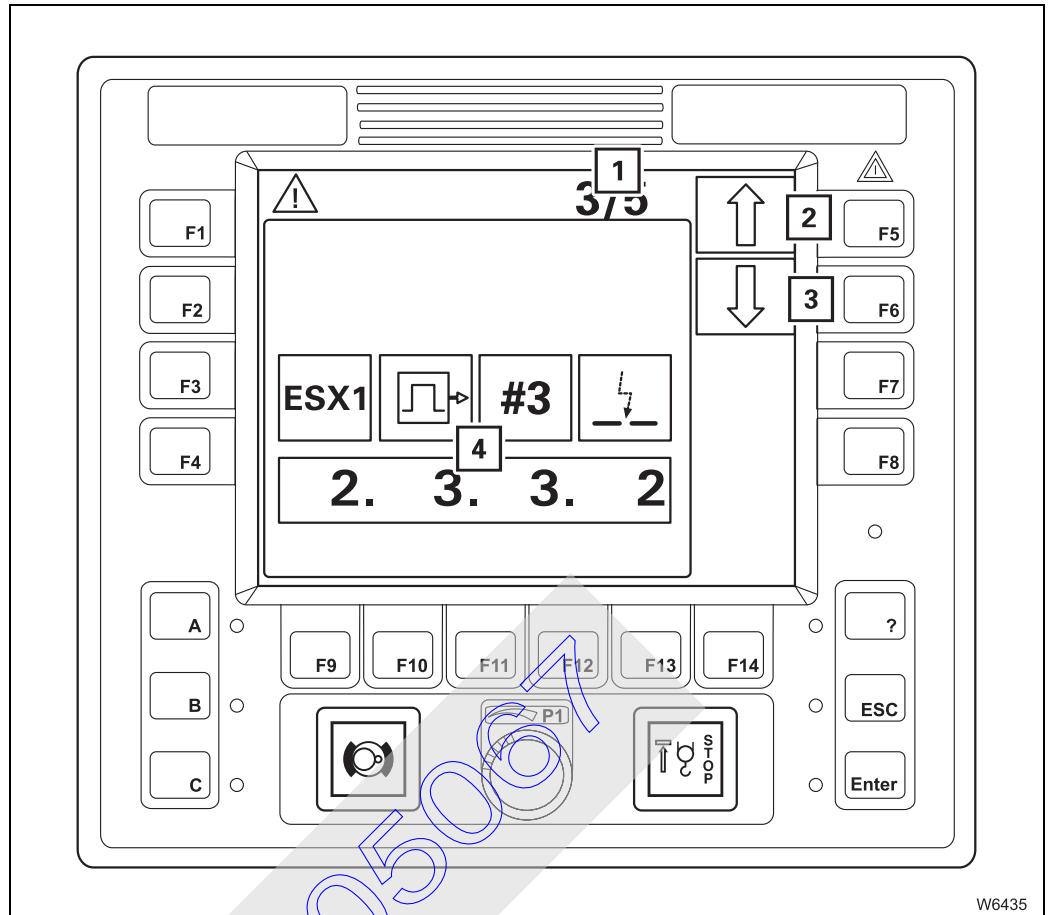

- | | |
|--|-----------------|
| 1 Display of current error / total errors | ▣▣▣▣ p. 15 - 33 |
| 2 Next error | ▣▣▣▣ p. 15 - 33 |
| 3 Previous error | ▣▣▣▣ p. 15 - 33 |
| 4 Error display | ▣▣▣▣ p. 15 - 33 |

Working range limitation sub-menu

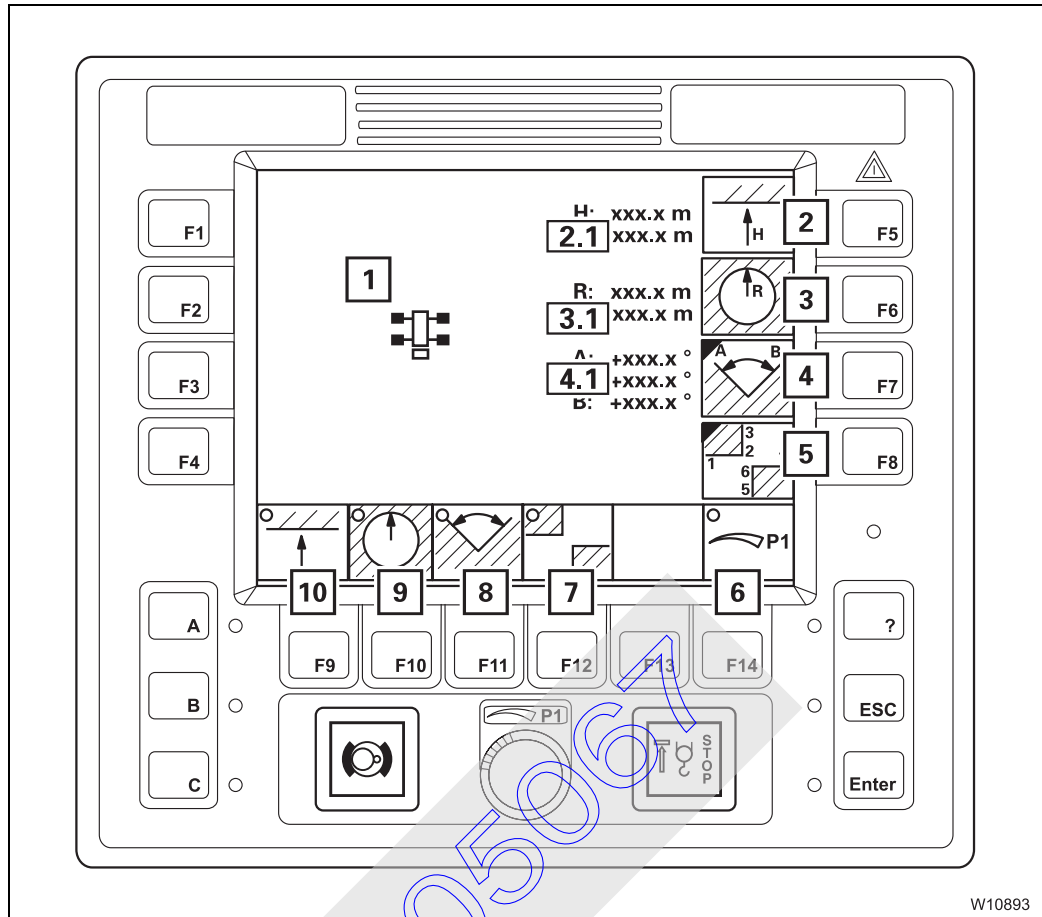

W10893

- | | |
|---|------------------|
| 1 Working range limitation display | ▣▣▣▣ p. 12 - 118 |
| 2 Enter maximum overall height | ▣▣▣▣ p. 12 - 110 |
| 2.1 Maximum overall height display | ▣▣▣▣ p. 12 - 110 |
| 3 Enter maximum working radius | ▣▣▣▣ p. 12 - 110 |
| 3.1 Maximum / Current working radius display | ▣▣▣▣ p. 12 - 110 |
| 4 Enter slewing angle submenu | ▣▣▣▣ p. 12 - 111 |
| 4.1 Maximum / Current slewing angle display | ▣▣▣▣ p. 12 - 111 |
| 5 Enter objects submenu | ▣▣▣▣ p. 12 - 113 |
| 6 Manual input on / off | ▣▣▣▣ p. 12 - 116 |
| 7 Object monitoring on / off | ▣▣▣▣ p. 12 - 118 |
| 8 Slewing angle monitoring on / off | ▣▣▣▣ p. 12 - 118 |
| 9 Working radius monitoring on / off | ▣▣▣▣ p. 12 - 118 |
| 10 Overall height monitoring on / off | ▣▣▣▣ p. 12 - 118 |

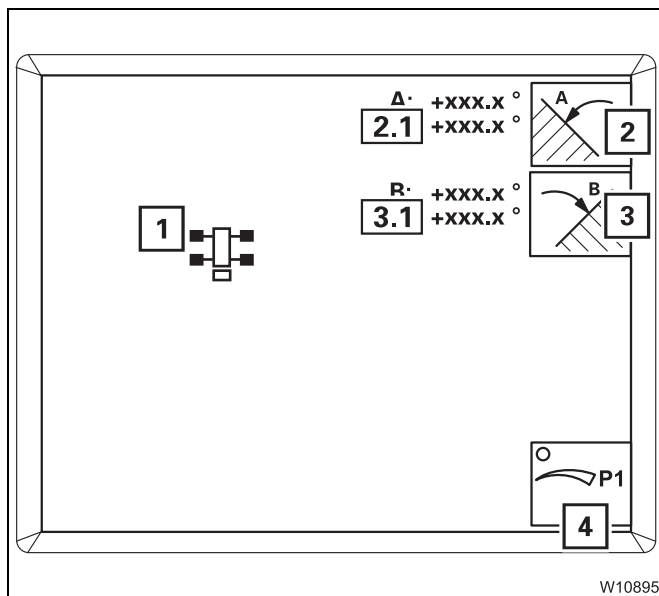

Enter slewing angle submenu

- 1 Limited slewing angle display
- 2 Select Slewing angle A
- 2.1 Maximum / Current slewing angle A display
- 3 Select Slewing angle B
- 3.1 Maximum / Current slewing angle B display
- 4 Manual input on / off

➡ *Slewing angle*, p. 12 - 111.

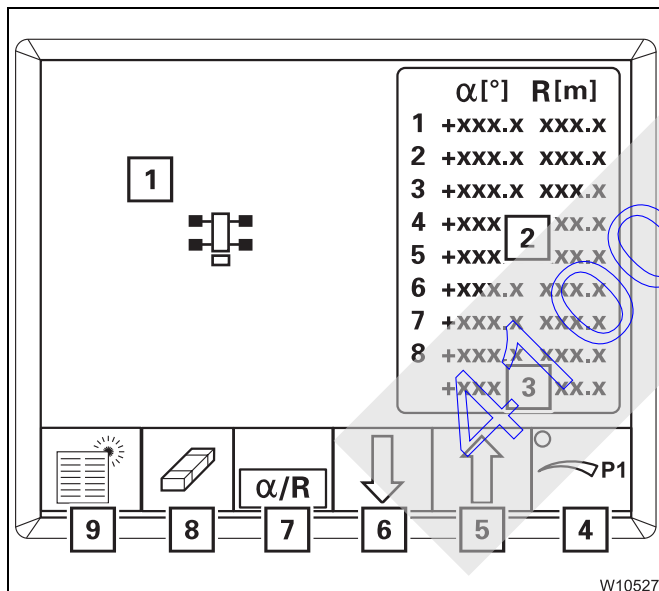

Enter objects submenu

- 1 Limitation by object display
- 2 Point data display
- 3 Current point data display
- 4 Manual input on / off
- 5 Select Previous point
- 6 Select next point
- 7 Select angle / working radius
- 8 Delete selected point data
- 9 Delete all point data

➡ *Entering objects*, p. 12 - 113.



Driving submenu

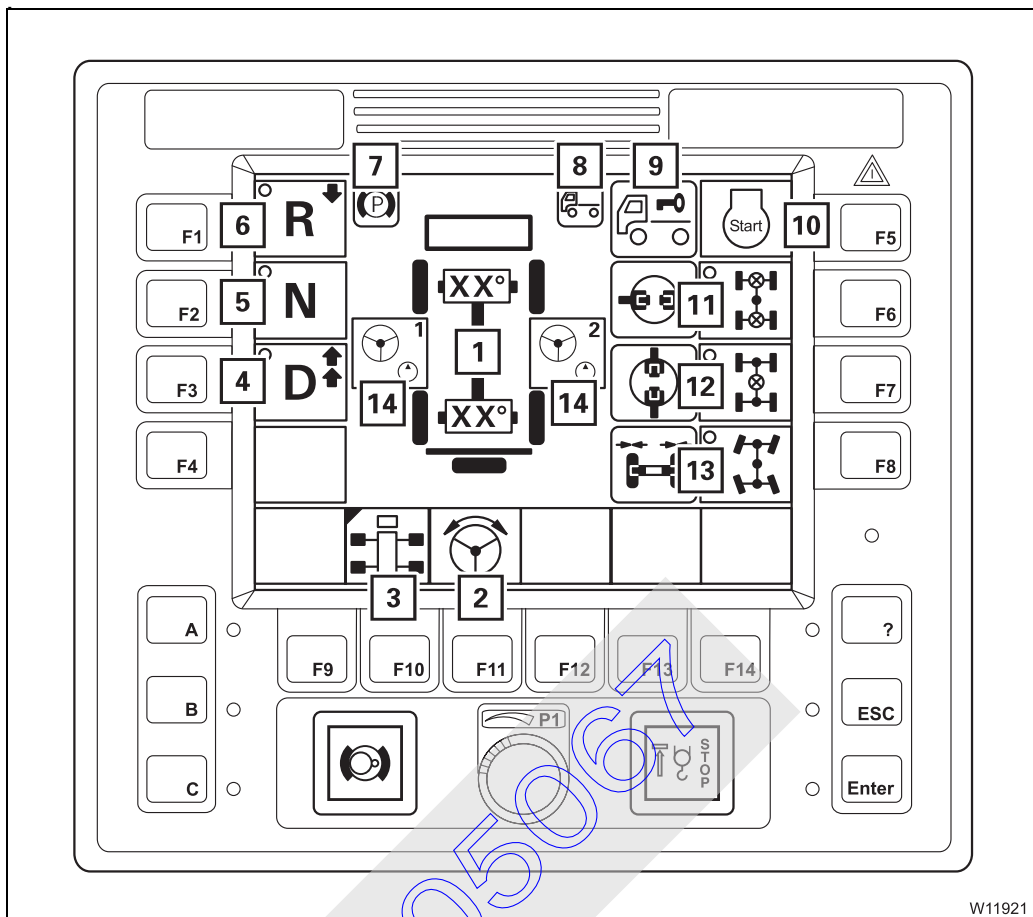

W11921

1 Steering display	▣▣▣▣ p. 10 - 104
2 Changing the steering direction	▣▣▣▣ p. 10 - 104
3 Outriggers submenu	▣▣▣▣ p. 10 - 24
4 Transmission mode D	▣▣▣▣ p. 10 - 101
5 Neutral position N	▣▣▣▣ p. 10 - 101
6 Transmission mode R	▣▣▣▣ p. 10 - 101
7 Parking brake display	▣▣▣▣ p. 10 - 103
8 Carrier ignition display	▣▣▣▣ p. 10 - 100
9 Steering lock display	▣▣▣▣ p. 10 - 99
10 Start engine for driving	▣▣▣▣ p. 10 - 100
11 Transverse differential locks display Transverse differential locks on / off	▣▣▣▣ p. 10 - 102 ▣▣▣▣ p. 10 - 102
12 Longitudinal differential locks display Longitudinal differential locks on / off	▣▣▣▣ p. 10 - 102 ▣▣▣▣ p. 10 - 102
13 Steering locking status display Separate steering on / off	▣▣▣▣ p. 10 - 105 ▣▣▣▣ p. 10 - 105
14 Warning for steering circuit 1 and steering circuit 2	▣▣▣▣ p. 10 - 104



41005061

10.1.10 SLI control unit

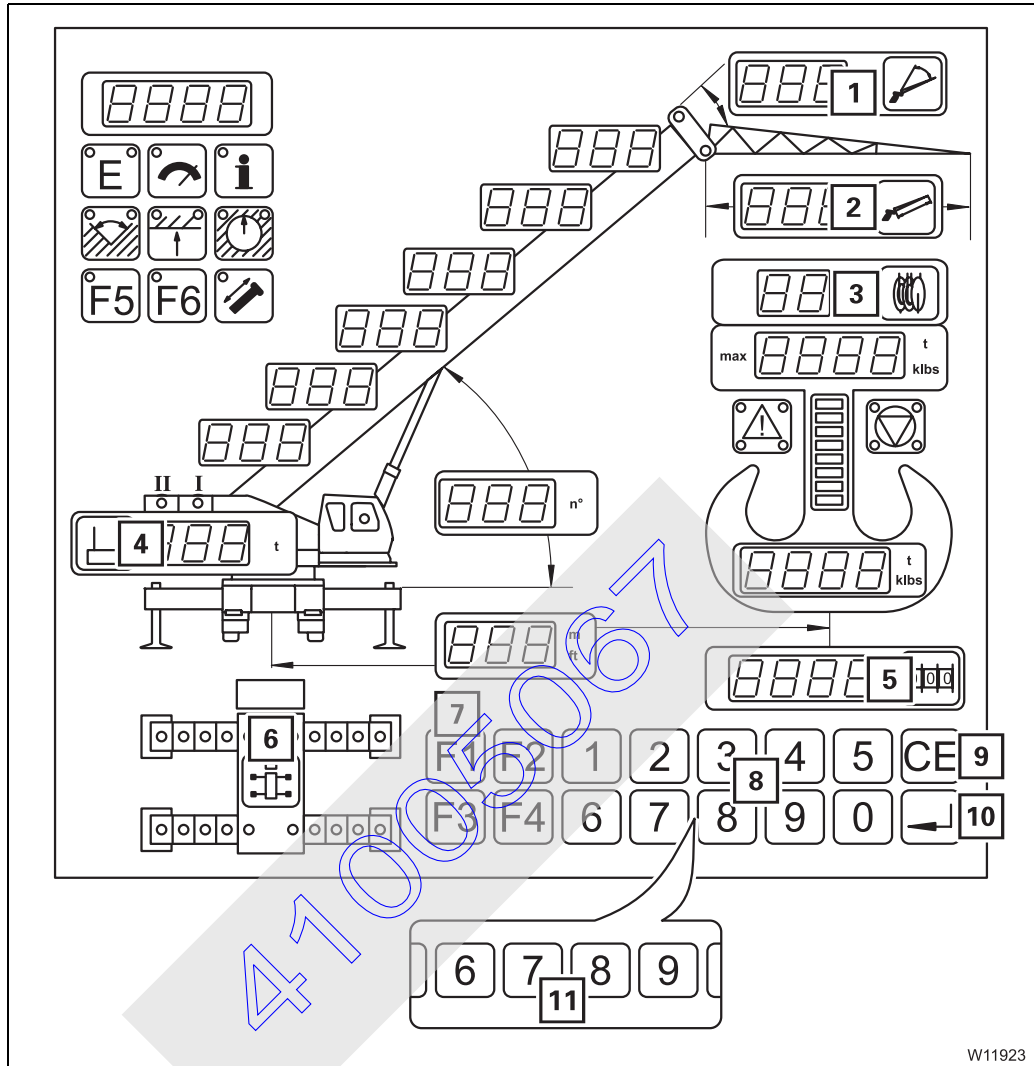

W11923

1 Lattice extension angle display and input ¹⁾	➡ p. 10 - 85
Current lattice extension inclination display ¹⁾	➡ p. 10 - 86
2 Lattice extension length display and input	➡ p. 10 - 84
3 Reeving display and input	➡ p. 10 - 84
4 Counterweight display and input	➡ p. 10 - 84
5 SLI code display and input	➡ p. 10 - 83
6 Outrigger span display and input	➡ p. 10 - 85
7 Additional function F1 on	➡ p. 10 - 83
8 Numerical pad	➡ p. 10 - 83
9 Acknowledge	➡ p. 10 - 84
10 Confirming an entry	➡ p. 10 - 84
11 Displaying and entering the time and date	➡ p. 12 - 39

¹⁾ Additional equipment



41005067

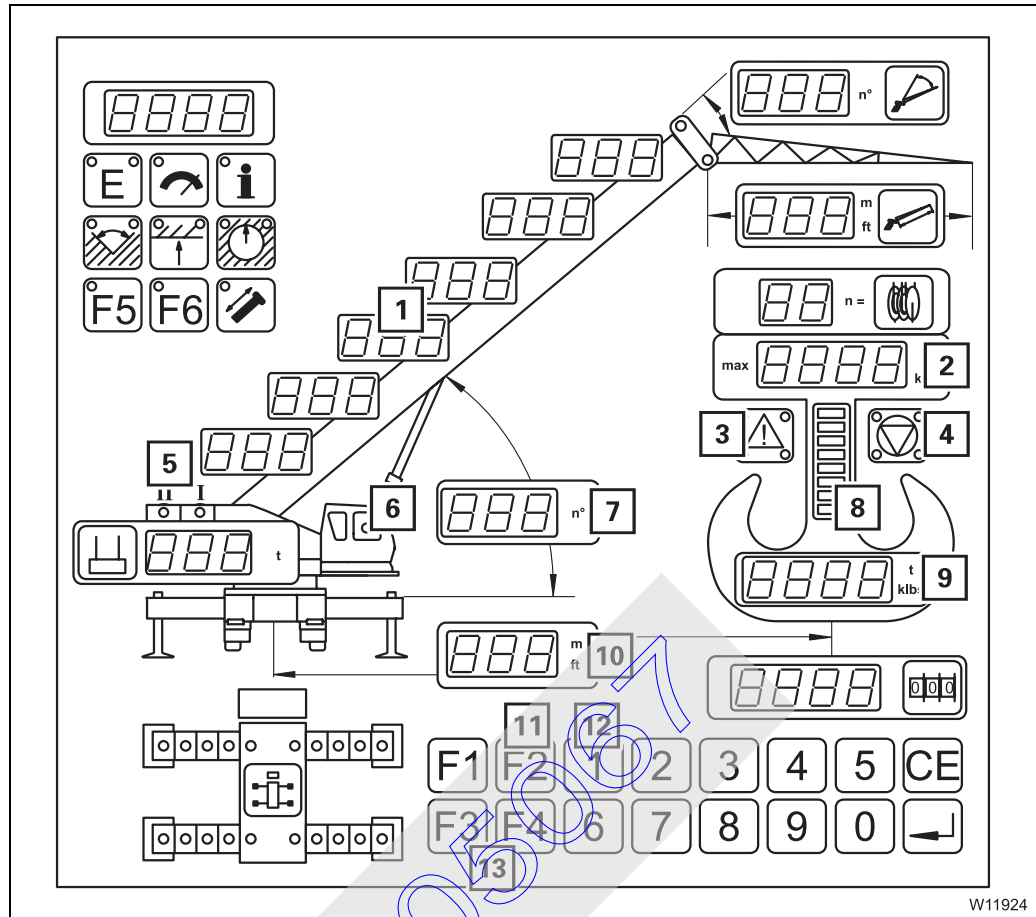

W11924

- | | | |
|---|-------|------------|
| 1 Current telescoping display | ▣▣▣▣▶ | p. 10 - 85 |
| 2 Maximum load display | ▣▣▣▣▶ | p. 10 - 86 |
| 3 SLI early warning | ▣▣▣▣▶ | p. 10 - 87 |
| 4 SLI shutdown | ▣▣▣▣▶ | p. 10 - 87 |
| 5 Hoists display | ▣▣▣▣▶ | p. 10 - 87 |
| 6 Sensor for brightness | ▣▣▣▣▶ | p. 10 - 88 |
| 7 Current main boom angle display | ▣▣▣▣▶ | p. 10 - 86 |
| 8 Current degree of utilization display | ▣▣▣▣▶ | p. 10 - 87 |
| 9 Current load display | ▣▣▣▣▶ | p. 10 - 86 |
| 10 Current working radius display | ▣▣▣▣▶ | p. 10 - 86 |
| 11 Additional function F2 on | ▣▣▣▣▶ | p. 10 - 88 |
| 12 Lamp test (as additional function F2) | ▣▣▣▣▶ | p. 10 - 88 |
| 13 F3 and F4 service buttons | ▣▣▣▣▶ | p. 10 - 88 |

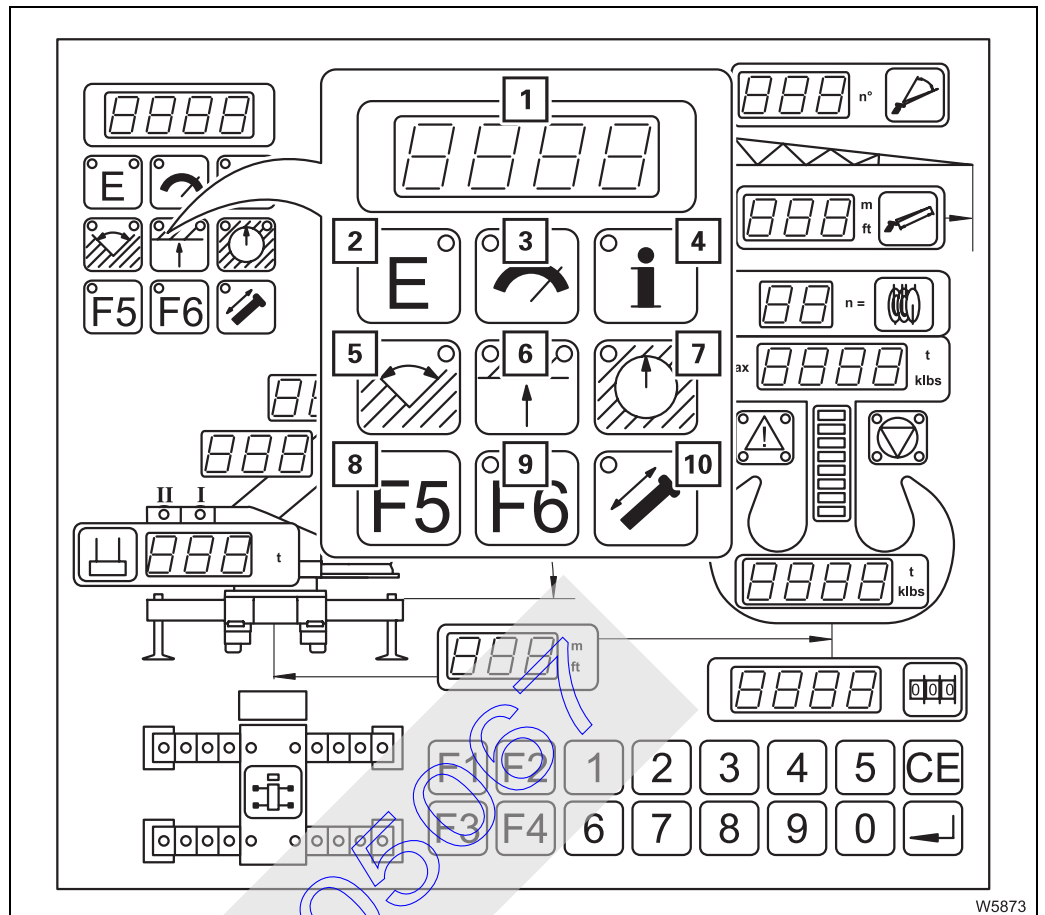

W5873

- | | | |
|--|-------|------------|
| 1 Information / error display | ▣▣▣▣▶ | p. 10 - 88 |
| 2 Displaying error information | ▣▣▣▣▶ | p. 12 - 33 |
| 3 Displaying the degree of utilization | ▣▣▣▣▶ | p. 12 - 33 |
| 4 Displaying the derricking cylinder oil pressure
(as additional function F5 and F6) | ▣▣▣▣▶ | p. 12 - 34 |
| 5 Displaying the current slewing angle | ▣▣▣▣▶ | p. 12 - 34 |
| 6 Display current overall height | ▣▣▣▣▶ | p. 12 - 34 |
| 7 Displaying current working radius | ▣▣▣▣▶ | p. 12 - 33 |
| 8 Additional function F5 on | ▣▣▣▣▶ | p. 12 - 34 |
| 9 Additional function F6 on | ▣▣▣▣▶ | p. 12 - 34 |
| 10 Displaying the current main boom length | ▣▣▣▣▶ | p. 12 - 33 |

10.1.11 Hand-held control

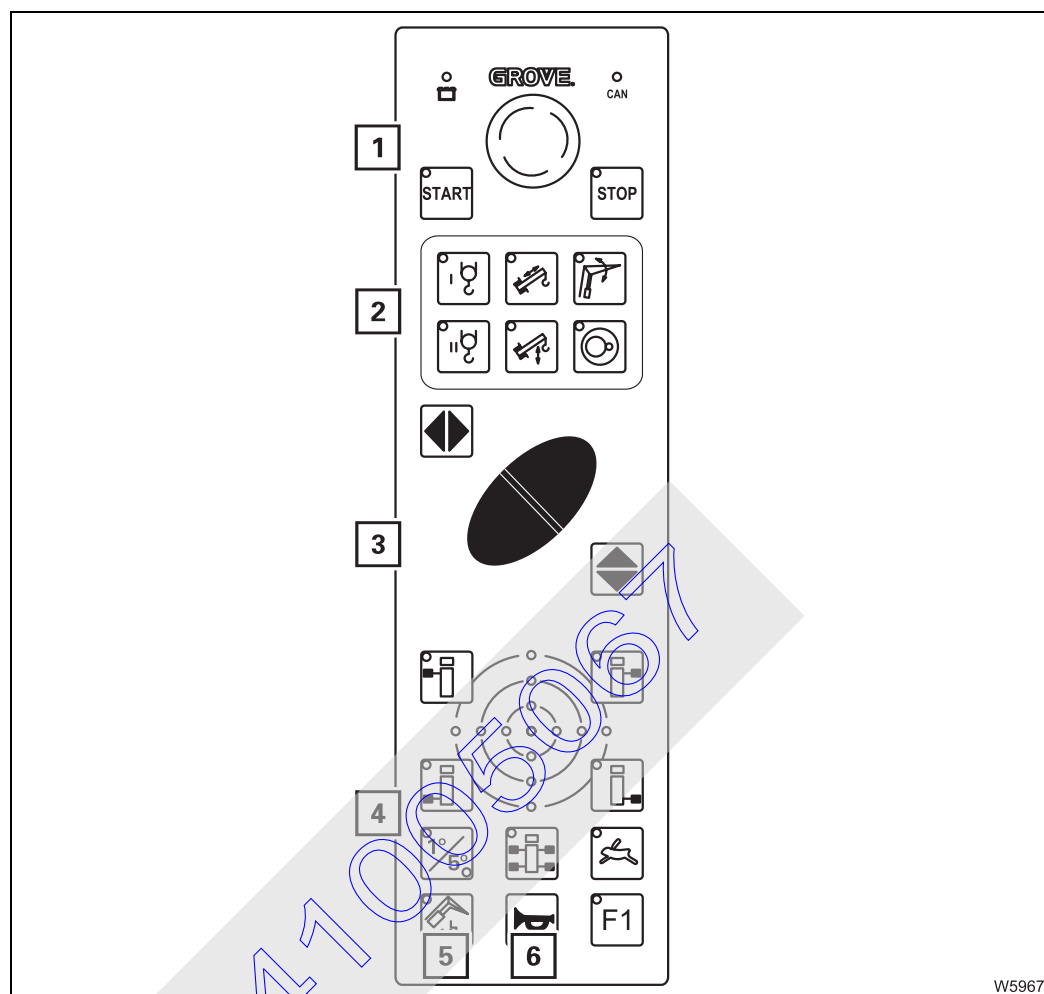

- | | |
|----------------------------------|------------------|
| 1 Engine control panel | ▣▣▣▣▶ p. 10 - 93 |
| 2 Pre-select emergency operation | ▣▣▣▣▶ p. 10 - 94 |
| 3 Function buttons | ▣▣▣▣▶ p. 10 - 94 |
| 4 Outriggers control panel | ▣▣▣▣▶ p. 10 - 93 |
| 5 No function | |
| 6 Horn | ▣▣▣▣▶ p. 10 - 93 |



Required connections for the various operations; ▣▣▣▣▶ p. 10 - 92.

Outriggers control panel

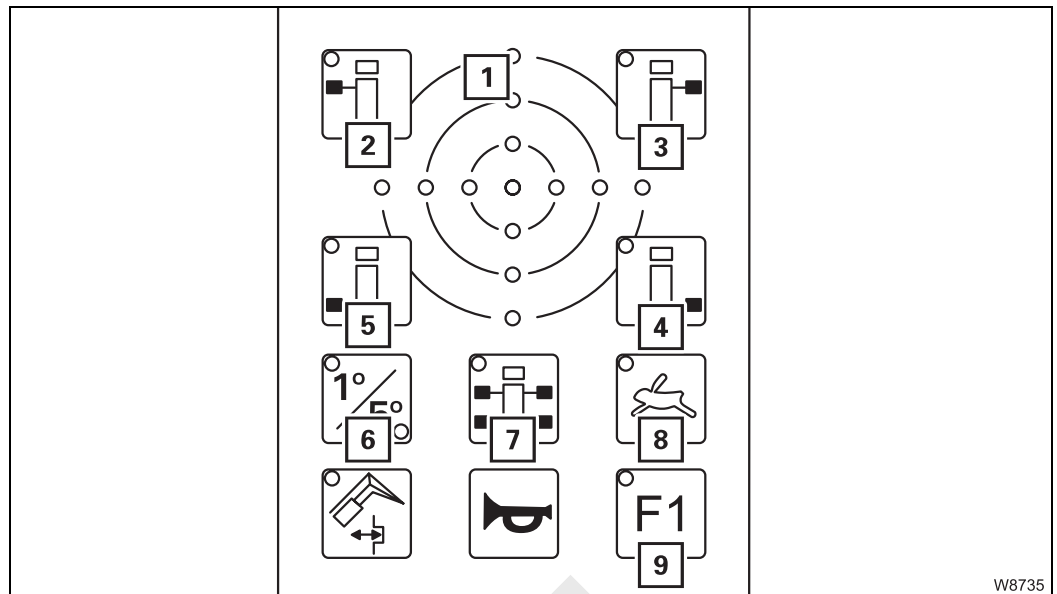

W8735

- | | |
|--|------------------------------------|
| 1 Display of current inclination | ▣▣▣▣ p. 10 - 63 |
| 2 Front left-hand outrigger | ▣▣▣▣ p. 10 - 58 |
| 3 Front right outrigger | ▣▣▣▣ p. 10 - 58 |
| 4 Rear left-hand outrigger | ▣▣▣▣ p. 10 - 58 |
| 5 Rear right-hand outrigger | ▣▣▣▣ p. 10 - 58 |
| 6 Switching over the measuring range | ▣▣▣▣ p. 10 - 63 |
| 7 – Pre-selecting all supporting cylinders
– Pre-select automatic alignment
(as additional function F1) | ▣▣▣▣ p. 10 - 58
▣▣▣▣ p. 10 - 58 |
| 8 Pre-select high-speed / normal speed mode | ▣▣▣▣ p. 10 - 58 |
| 9 Additional function F1 on | ▣▣▣▣ p. 10 - 58 |

10.1.12 Outrigger control units

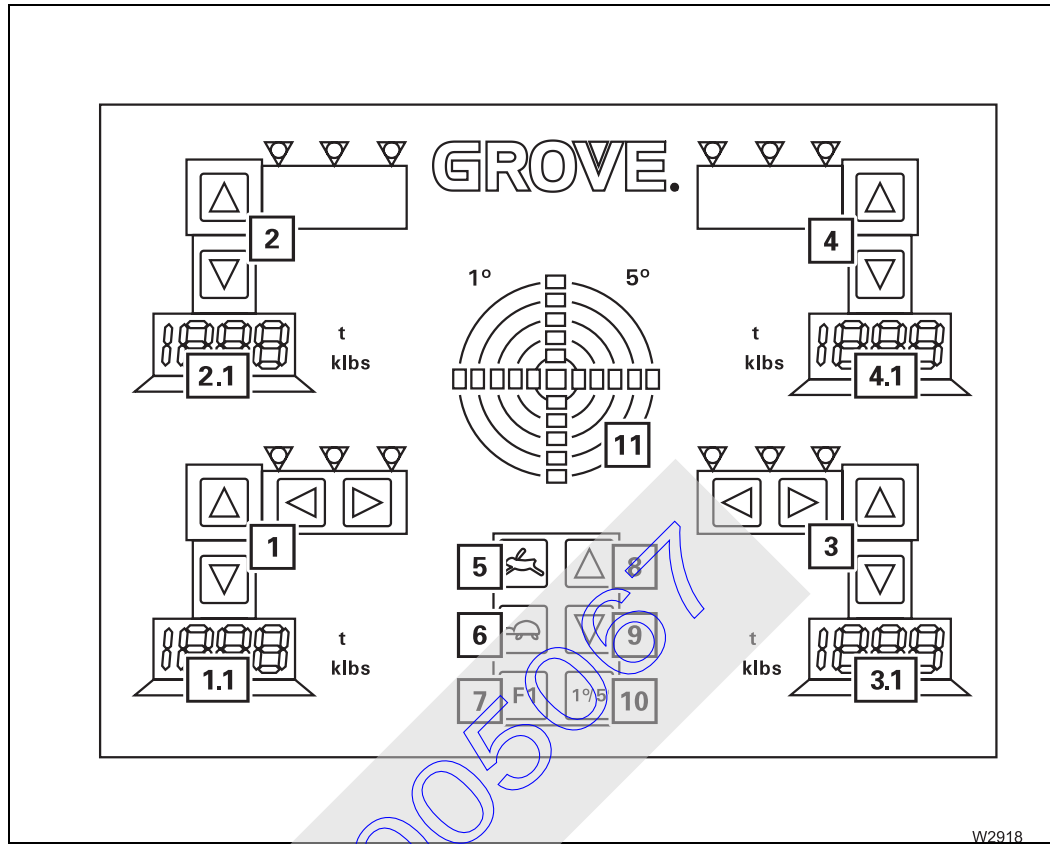



Opposite means: on the side of the carrier which is opposite to the operator when he / she is looking at the control unit.

Left-hand and right-hand mean: to the left or to the right of the control unit.

Outriggers

- | | | |
|---|---|-----------------|
| 1 | Operating the left-hand outrigger | ▣▣▣▣ p. 10 - 61 |
| 2 | Operating the left-hand outrigger, opposite side | ▣▣▣▣ p. 10 - 61 |
| 3 | Operating the right-hand outrigger | ▣▣▣▣ p. 10 - 61 |
| 4 | Operating the right-hand outrigger, opposite side | ▣▣▣▣ p. 10 - 61 |
| 5 | Pre-select high-speed mode | ▣▣▣▣ p. 10 - 61 |
| 6 | – Pre-select normal mode | ▣▣▣▣ p. 10 - 61 |
| | – Automatic alignment
(as additional function F1) | ▣▣▣▣ p. 10 - 62 |
| 7 | Additional function F1 on / Position lights for indicator lamps | ▣▣▣▣ p. 10 - 62 |
| 8 | Retracting all supporting cylinders | ▣▣▣▣ p. 10 - 62 |
| 9 | Extending all supporting cylinders | ▣▣▣▣ p. 10 - 62 |

Outrigger pressure display

- | | | |
|-----|--|-----------------|
| 1.1 | Outrigger pressure display ¹⁾ for left-hand outrigger | ▣▣▣▣ p. 10 - 64 |
| 2.1 | Outrigger pressure display ¹⁾ for left-hand outrigger, opposite side | ▣▣▣▣ p. 10 - 64 |
| 3.1 | Outrigger pressure display ¹⁾ for right-hand outrigger | ▣▣▣▣ p. 10 - 64 |
| 4.1 | Outrigger pressure display ¹⁾ for right-hand outrigger, opposite side | ▣▣▣▣ p. 10 - 64 |

¹⁾ Additional equipment

Inclination display

- | | | |
|----|------------------------------------|-----------------|
| 10 | Switching over the measuring range | ▣▣▣▣ p. 10 - 63 |
| 11 | Display of current inclination | ▣▣▣▣ p. 10 - 63 |

Blank page

41005067

10.2

Short description of the operating elements



Risk of accidents due to operating error

This section is not a complete operating manual. It only provides a general overview of the operating element functions.

Before using the operating elements for the first time, read through the following chapters and the safety instructions listed there.



This section does not contain all of the requirements that must be fulfilled in order for several operating elements to be active.

If some operating elements do not work, first read the following chapters which are referred to at the respective places before contacting **CraneCARE**.

10.2.1

Definition of positional references

Basic rule

Directions always depend on whether the carrier or the superstructure is being operated.

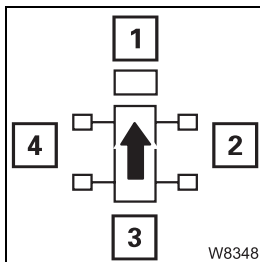

On the carrier

The driver's cab is always at the front, which means that:

- 1: front
- 2: right
- 3: rear
- 4: left

Forwards always means the driver's cab is to the front of the direction of travel,

backwards always means the rear lights on the carrier are to the front of the direction of travel.

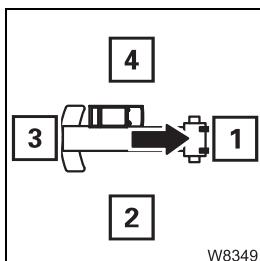

On the superstructure

The main boom head is always at the front, which means that:

- 1: front
- 2: right
- 3: rear
- 4: left



Switch

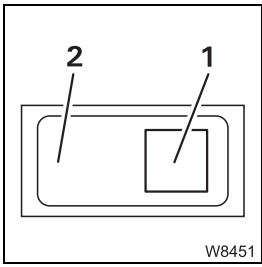

For switches and buttons, the terms **down** and **up** are used. Regardless of the fitting position (vertical, horizontal, diagonal, perpendicular or turned), the following always applies:

- **down:** press (1) – on the symbol
- **up:** press (2) – opposite the symbol

10.2.2

General rules for buttons and symbols on the display

The symbols shown as an example are not present on all crane types. The following rules apply in all menus:

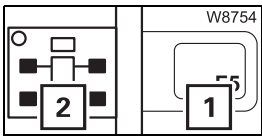

- A button (1) is only active when the corresponding symbol (2) is black. Buttons next to a grey symbol always have no function.

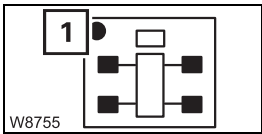

- Some symbols have a dot (1). The colour of the dot indicates the current switching state of the button.

- **Green:** button on – the corresponding switching operation is being carried out
- **Black:** button off – the corresponding switching operation is not being carried out

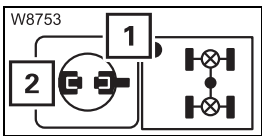

For some elements, the dot (1) only indicates that the switching operation has been completed. Here, you will also receive a report on the current switching state on an extra display (2).

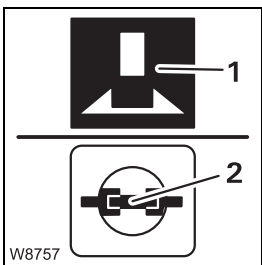

- In these operating instructions, we always refer to colours in terms of “The symbol is red”, for instance. Regardless of whether the background (1) of a symbol is red or whether only parts (2) of a symbol are red. This applies to all symbols and all colours.

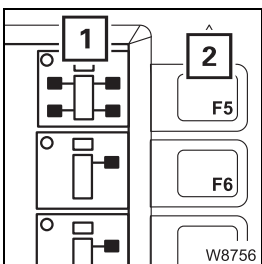

- If it says in this section e.g. to “Press button 1...”, this always refers to the button (2) next to or below the symbol shown (1). Even when the button itself is not visible in the illustration.

10.2.3

Engine for crane operation

Side panel

▣▣▣▣ To start the engine, p. 11 - 12.

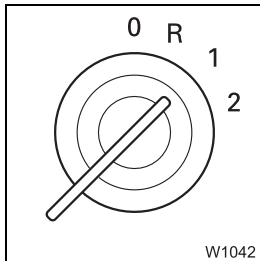

Ignition lock

- **0** Ignition off, engine off, key can be removed
- **R, 1** Ignition on and power supply on for: instrument lighting, ECOS, engine control system, SLI
- **2** Starting position

▣▣▣▣ p. 11 - 9

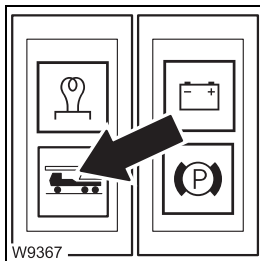

Carrier ignition indicator lamp

- **On:** ignition in driver's cab on, engine start not possible
- **Off:** ignition in driver's cab off, engine start possible

▣▣▣▣ p. 11 - 12

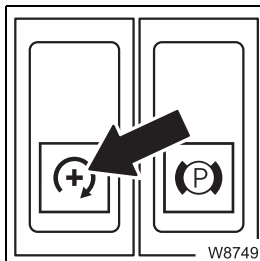

Setting the idling speed

- The engine is off:
 - **press down once:** engine starts, idling speed = standard
- The engine is running:
 - **press down:** increases the idling speed
 - **press up:** decreases the idling speed, after about 6 seconds: engine STOP

▣▣▣▣ p. 11 - 16

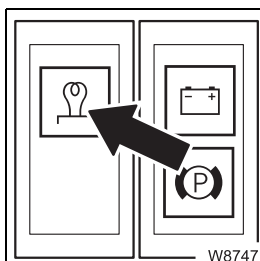

Flame start system indicator lamp

- **On:** engine not ready to start – is being warmed up
- **Off:** engine is ready to start

▣▣▣▣ p. 11 - 13



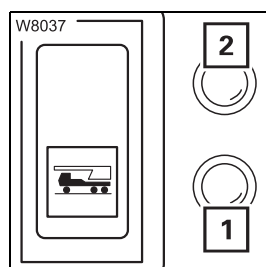

Soot particle filter indicator lamp – Version 1

- 1 **Yellow lamp lights up:** early warning: clean soot particle filtering
- 2 **Orange lamp lights up:** clean / replace soot particle filtering;
 ▣▣▣▣ *Maintenance manual*

ECOS display

There is no short description of the displays in the submenus;

▣▣▣▣ *Monitoring submenu*, p. 11 - 15,

▣▣▣▣ *Warning submenu*, p. 12 - 102.

41005067

10.2.4

Engine for driving

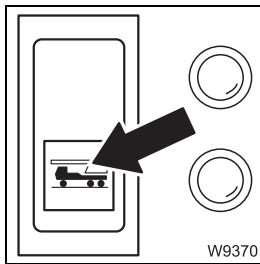

Carrier ignition on / off

There is an indicator lamp in the button.

The superstructure ignition has been switched on for about 30 min.

- **Press down once:** ignition on – lamp flashes
after engine start: lamp lights up
- **Press up once:** ignition off – lamp is off while engine is running –
engine cutout

➡ p. 13 - 21

Outriggers sub- menu

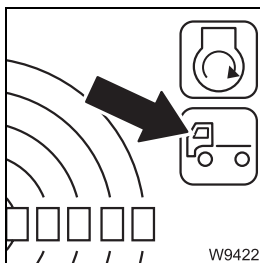

Carrier ignition display

- **Red:** ignition off – engine start not possible
- **Green:** ignition on – engine start possible

➡ p. 13 - 23

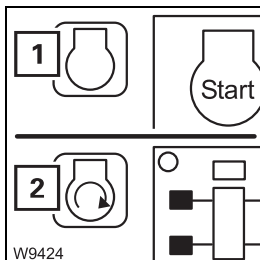

Display for engine for driving on / off

- 1 Red:** engine off
- 2 Green:** engine on

➡ p. 13 - 23

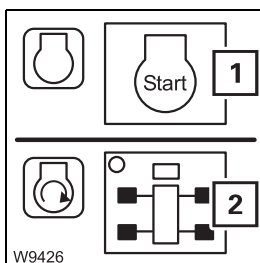

Start engine for driving

- 1 Starting the engine:** press button once
- 2 Motor running:** button has function *Pre-select all supporting cylinders*

Turning off the engine: switch off the carrier ignition

➡ p. 13 - 23

10.2.5

Seat contact switch and dead man's switch

The seat contact switch and the dead man's switch are safety devices for crane function enabling.

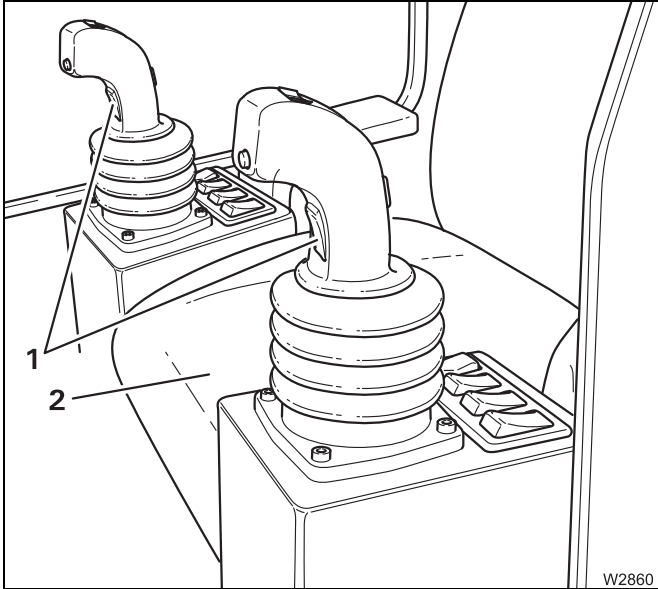

Enable crane functions

- Sit down – seat contact switch (2) on
- or
- Press at least one dead man's switch (1)

Safety function on

- Get off seat – seat contact switch off
 - and
 - Both dead man's switches (1) not pressed
- All operating elements for crane functions in the crane cab are locked.

Any crane movements are slowed down to standstill within 3 seconds and then locked.

Crane cab seat – version 2

The seat contact switch responds very sensitively. It is recommended that you also press the dead man's switch in order to avoid unintentional shut-down.

▣▣▣▣ ▶ *Seat contact switch*, p. 12 - 11

10.2.6

ECOS crane control

The truck crane GMK 4100 is equipped with the **ECOS** electronic crane control (**E**lectronic **C**rane **O**perating **S**ystem). ECOS includes a control unit in the crane cab, an operating unit in the driver's cab and several control units (ESX0, ESX1, ESX2 etc.) and I / O circuit boards (I/O 0, I/O 1 etc.), which are distributed on the superstructure and carrier.

Control unit

This section contains the operating elements that are the same for all menus opened.

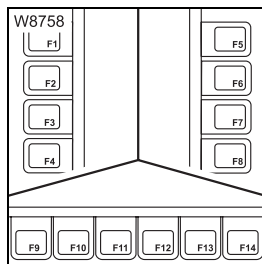

Buttons F1 to F14

The function of buttons F1 to F14 is shown on the symbol next to or above the button. After the button is pressed, the function displayed is executed if it has been released.

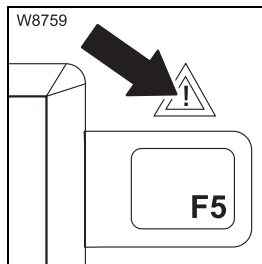

Error / warning message

- **Flashing:** new warning message or error has occurred
- **On:** error acknowledged – but still present
- **Off:** no warning message or error present

▶▶▶▶▶ p. 12 - 106

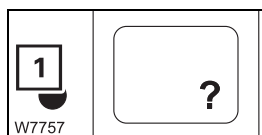

Opening the error submenu

The lamp (1) lights up or flashes.

- **Press button once:** the *Error* submenu opens

▶▶▶▶▶ p. 12 - 106

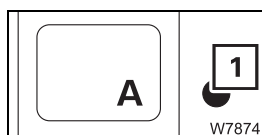

Opening the warning submenu

The lamp (1) lights up or flashes.

- **Press button once:** the *Warning* submenu for the superstructure opens

▶▶▶▶▶ p. 12 - 102



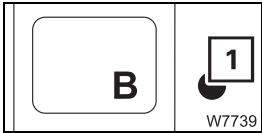

Opening the warning submenu

The lamp (1) lights up or flashes.

- **Press button once:** the *Warning* submenu for the carrier opens

▣▣▣▣ p. 12 - 102

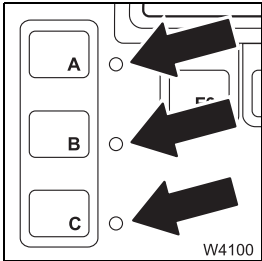

Entering the keycode

The lamps next to all three buttons are lit.

- **Enter keycode:** press buttons in the required order and confirm keycode.

▣▣▣▣ *Telescoping emergency program*, p. 15 - 39



Exiting the submenu / input mode

The lamp (1) lights up.

- **Press button once:**
 - the opened submenu closes – the menu from the next level up opens
 - Input mode is deactivated



Confirming an entry

The lamp (1) lights up.

- **Press button once:** a newly entered value is stored

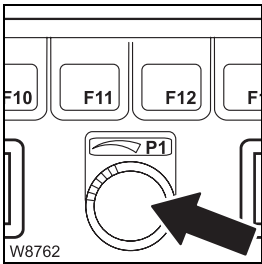

Entering values

Input mode is activated.

- **To the right:** increases the value
- **To the left:** reduces the value

Slow turning changes the value slowly.
 Fast turning changes the value fast.

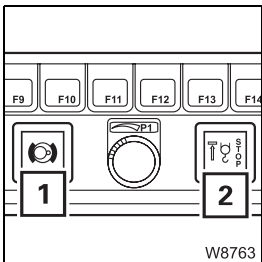

Other

- 1 Slewing gear brake indicator lamp; ▣▣▣▣ p. 10 - 71
- 2 Lifting limit switch warning; ▣▣▣▣ p. 10 - 71

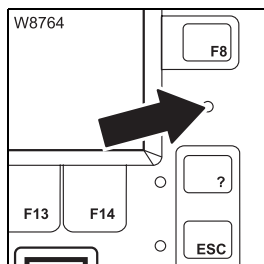

Sensor for brightness

Registers the brightness of the operating environment. The brightness of all displays is automatically adjusted.
Manual input; p. 11 - 9.

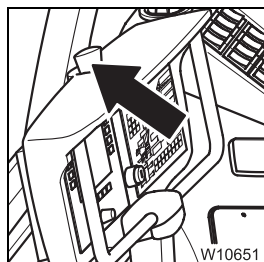

Emergency stop switch

May be actuated in an emergency only.

- **Press:** engine off – crane functions stop immediately
switch engages
- **Turn engaged switch:** switch returns to initial position – crane functions released

p. 11 - 20

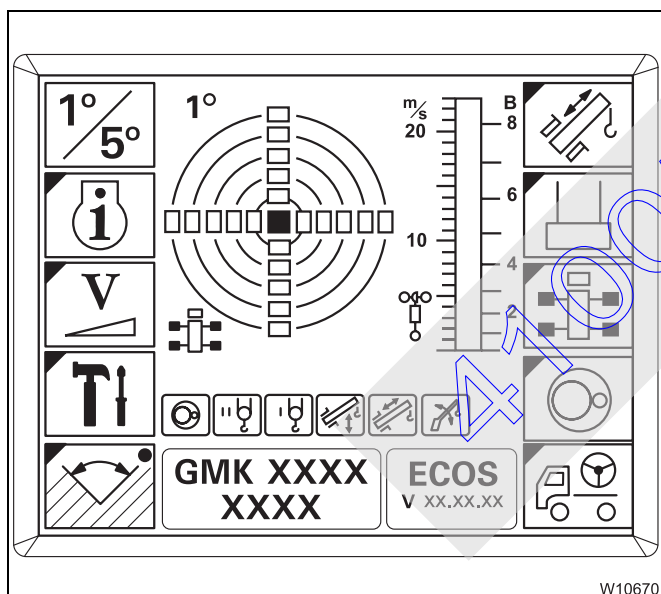

ECOS display

Ignition on – Main menu display

Symbols with blue corner = submenu

Open submenu – Press the button next to symbol 1 x.

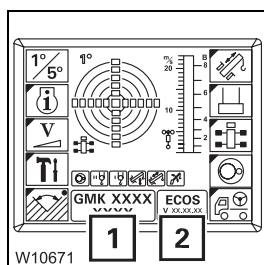

Serial number and program version displays

- 1 Serial number
- 2 Current ECOS program version – always state in the event of malfunctions; p. 15 - 32.

10.2.7

Outriggers

▣▣▣▣▶ *Extending / retracting outriggers, p. 13 - 32*

▣▣▣▣▶ *Extending / retracting supporting cylinders, p. 13 - 41*

Hand-held control

All directional information relates to the carrier; ▣▣▣▣▶ p. 10 - 49.

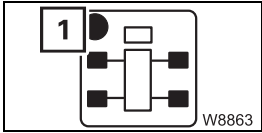

Pre-selecting all supporting cylinders

- **Pre-select:** press button once – lamp (1) lights up – pre-selection on after 10 seconds – lamp (1) goes out – pre-selection off

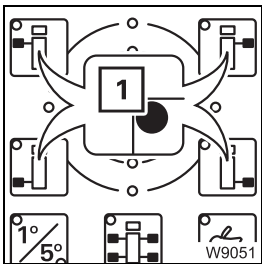

The following functions are pre-selected in the same way:

- **Front left-hand outrigger**
- **Front right-hand outrigger**
- **Rear left-hand outrigger**
- **Rear right-hand outrigger**

As long as the lamp (1) is on, you can pre-select additional outriggers.

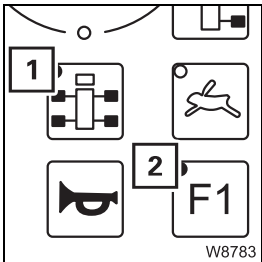

Pre-select automatic alignment

- **Pre-select:** press button once, press button once, lamps (1) and (2) light up – pre-selection on After 10 seconds – lamps go out – pre-selection off

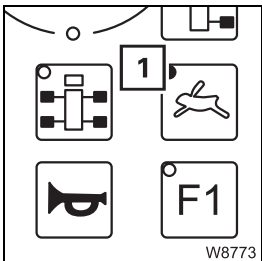

Pre-select high-speed / normal speed mode

- **Pre-select:**
 - press button once – lamp (1) lights up – high-speed mode pre-selection on
 - press button once – lamp (1) goes out – normal speed mode pre-selection on

Function buttons

There are four button combinations to execute the pre-selected functions. Actuated buttons are shown in black:

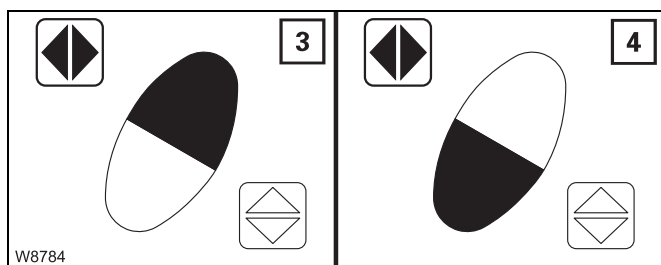

W8784

Supports

Only supports on the same side have been pre-selected.

3 Extend

4 Retract

▣▣▣▣ p. 13 - 34

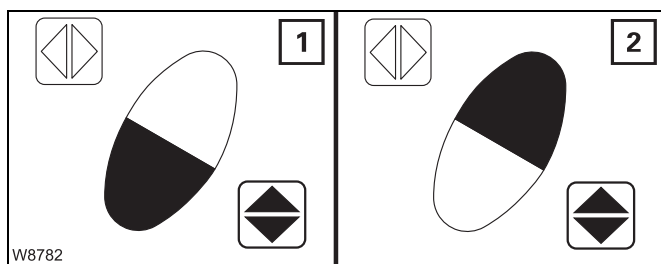

W8782

Supporting cylinders

1 Extend

Automatic alignment

2 Retract

▣▣▣▣ p. 13 - 43

In the outriggers submenu

All directional information relates to the carrier; ▣▣▣▣ p. 10 - 49.

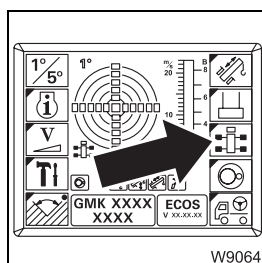

W9064

Outriggers submenu

- To open: press button once – submenu opens

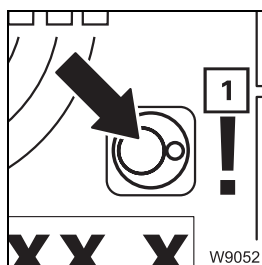

W9052

Slewing gear / movements locked display

- **Red:** slewing gear switched off

- **Green:** slewing gear switched on – outrigger movement locked, symbol (1) appears after pre-selection of the outrigger



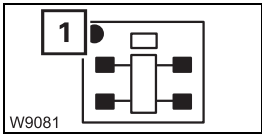

Pre-selection of the outrigger

All supporting cylinders

- **Pre-select:** press button once – dot (1) green – pre-selection on
 after 10 seconds – dot (1) black – pre-selection off

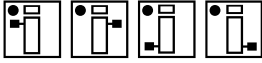

The following functions are pre-selected in the same way:

- **Front left-hand outrigger**
- **Front right-hand outrigger**
- **Rear left-hand outrigger**
- **Rear right-hand outrigger**
- **Left-hand supporting cylinder**
- **Right-hand support cylinder**
- **Front supporting cylinder**
- **Rear supporting cylinder**

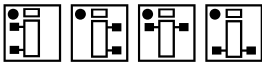

Retract / Extend supporting cylinders

The slewing gear is switched off – outrigger pre-selection on.

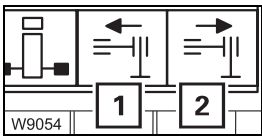

- 1 To retract:** press button – supporting cylinder retracts
- 2 To extend:** press button – supporting cylinder extends

➡ p. 13 - 36

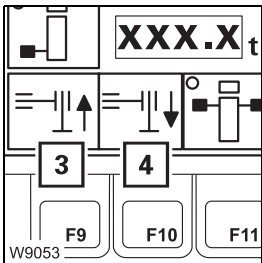

- 3 To retract:** press button – supporting cylinder retracts
- 4 To extend:** press button – supporting cylinder extends

➡ p. 13 - 44

The movement stops after the button is released and when an end position is reached.

In the settings submenu

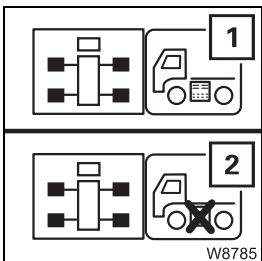

Outrigger control units on / off

- **To switch on:** press button until symbol (1) appears
- **To switch off:** press button until symbol (2) appears

➡ p. 13 - 29

On the outrigger control units

All directional information relates to the carrier;  p. 10 - 49.

For operation in crane mode, the display fields in the *Settings* submenu need to be switched on.

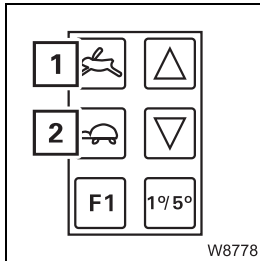

Pre-select high-speed / normal speed mode

- 1 Pre-select:** press button – high-speed mode pre-selection on
- 2 Pre-select:** press button – normal speed pre-selection on

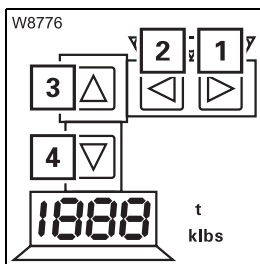

Operating the left-hand outriggers (next to control unit)

Button  or  is pressed.

- 1 To retract:** press button – the support retracts¹⁾
- 2 To extend:** press button – the support extends¹⁾
- 3 To retract:** press button – supporting cylinder retracts
- 4 To extend:** press button – supporting cylinder extends

¹⁾ only on operator's side

Supports;  p. 13 - 33

Supporting cylinders;  p. 13 - 42

The movement stops after the button is released, and when an end position is reached.

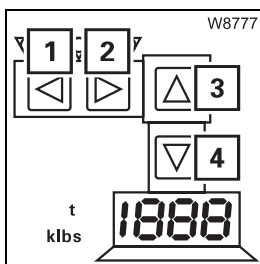

Operating the right-hand outriggers (next to control unit)

Operation is the same as on the button unit for *Outriggers to the left of display field*.



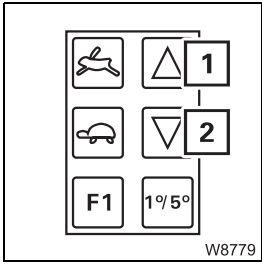

Retracting / Extending all supporting cylinders

Button or is pressed.

- 1 To retract:** press button – all supporting cylinders retract
- 2 To extend:** press button – all supporting cylinders extend

The movement stops after the button is released, and when an end position is reached; p. 13 - 42.



Additional function F1 on

Use always in combination with other buttons.

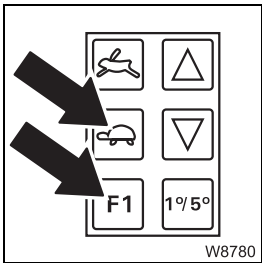

– Automatic alignment

Press and additionally – truck crane is aligned horizontally

The process stops as soon as the truck crane is aligned horizontally or when releasing the button.

p. 13 - 49

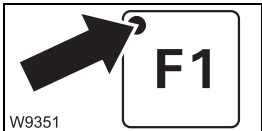

Position lights for indicator lamps

Light up when the ignition is on.

- **Display field lighting off:** ignition on and no button actuated yet or no button actuated within the last 10 seconds
- **Display field lighting on:** press any button

p. 13 - 33

10.2.8 Inclination displays

▣▣▣▣ ▸ *Inclination displays*, p. 13 - 46

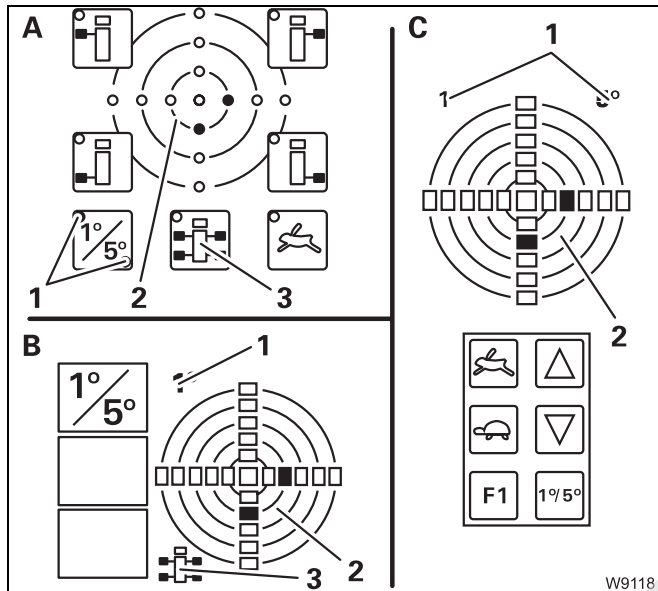

Display of current inclination

- A** On the hand-held control
- B** In the main menu
In the *Outriggers submenu*
- C** On the *Outrigger control units*

- 1** Measuring range display
- 2** Inclination display
- 3** Directional indicator

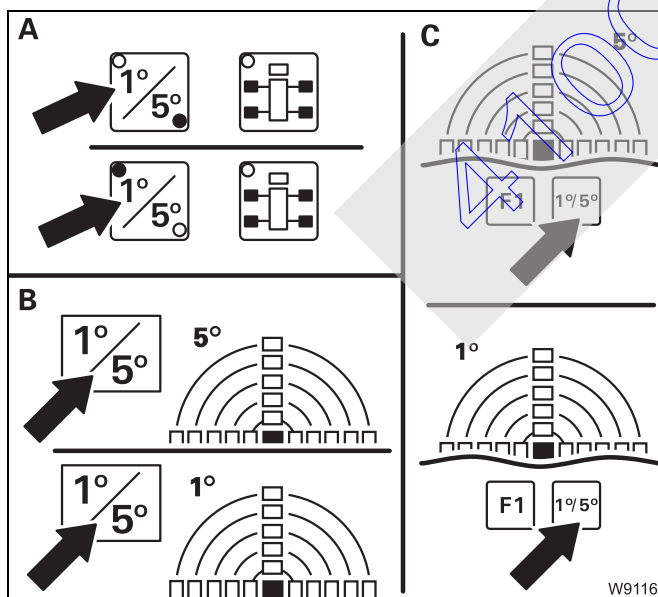

Switching over the measuring range

- A** On the hand-held control
Press button once – lamp for current measuring range 1° or 5° lights up
- B** In the main menu
In the *Outriggers submenu*
- C** On the *Outrigger control units*
Press button once – the current measuring range 1° or 5° is shown

10.2.9

Outrigger pressure displays

Outriggers sub-menu

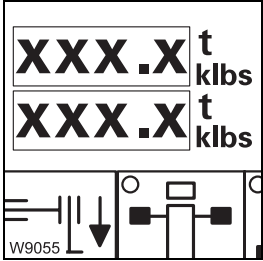

Outrigger pressure display

- **Unit of measurement:**
 - is displayed, depending on setting
 - **t** – tons or
 - **klbs** – kilopounds – (1 kilopound = 1,000 lbs)
- **Precision:** one decimal place

➡ p. 13 - 53

Outrigger control units

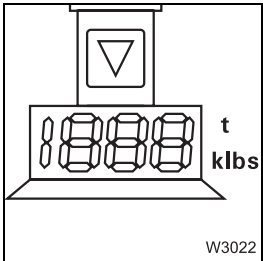

Outrigger pressure display

- **Unit of measurement:** lights up, depending on setting
 - **t** – tons or
 - **klbs** – kilopounds – (1 kilopound = 1,000 lbs)
- **Precision:**
 - with **t**, one decimal place
 - with **klbs** no decimal point

➡ p. 13 - 53

10.2.10

Anemometer display

This function is the same in all the menus.
The anemometer is electrically connected.

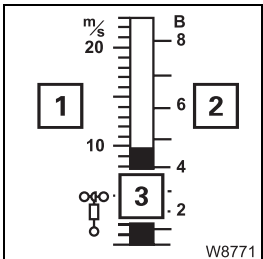

- 1 Scale in meters per second (m/sec)
- 2 Beaufort scale (B)
- 3 Display of wind speed

➡ p. 12 - 42

10.2.11 Counterweight submenu

Counterweight submenu

- ▣▣▣▣ *Rigging / unrigging the counterweight*, p. 13 - 55,
- ▣▣▣▣ *counterweight hoist unit*, p. 13 - 72.

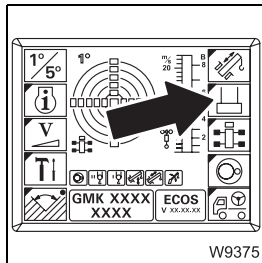

Counterweight submenu

- **To open:** press button once – submenu opens

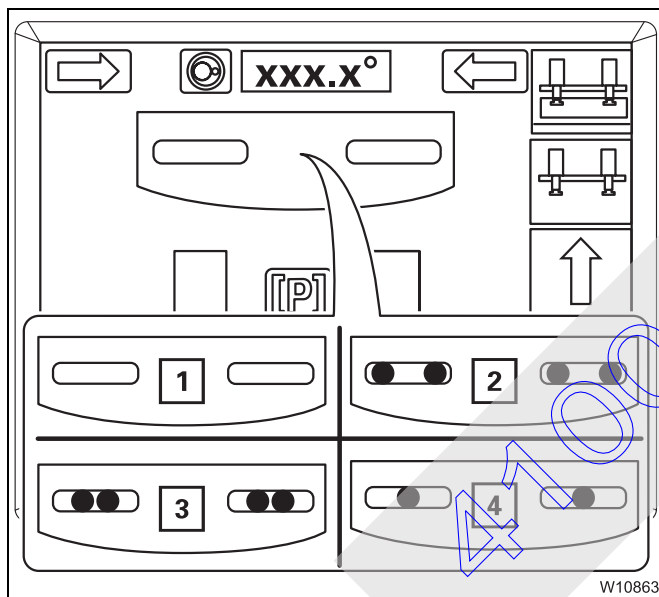

Rigging position display

- 1** white – not in the rigging range

In the rigging range, the following rigging positions are displayed.

- 2** green – position for lifting cylinder movements
- 3** red – intermediate position, lifting cylinder movements locked
- 4** green – position for lifting / lowering the counterweight (0° position)

- ▣▣▣▣ p. 13 - 74

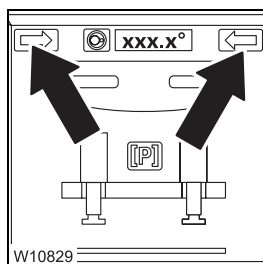

Display of slewing direction for automatic mode

The automatic mode is switched on.

- **Arrow lights up:** move control lever for slewing gear in direction of arrow – automatic mode is executed



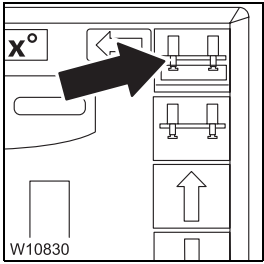

Rigging automatic mode

- **Display**
 - Yellow:** recognition that counterweight is rigged
 - Flashing:** automatic mode on
 - Grey:** automatic mode cancelled or no recognition that counterweight is rigged

The superstructure is within the rigging range, the slewing gear is switched on and the lifting cylinders are retracted

- **To switch on:** press button once – symbol flashes yellow
- **To execute:** move control lever for slewing gear, automatically:
 - slewing in position *Move lifting cylinders*
 - extend lifting cylinders,

Move control lever for slewing gear in indicated direction, automatically:

- slewing in position *Lift / lower counterweight*,
- lift counterweight,
- pre-tension counterweight.

Automatic mode ends – symbol yellow

▣▣▣▣ p. 13 - 74

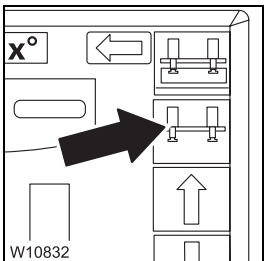

Unrigging automatic mode

- **Display**
 - Yellow:** recognition that counterweight is unrigged
 - Flashing:** automatic mode on
 - Grey:** automatic mode cancelled or no recognition that counterweight is unrigged

The superstructure is in the rigging range and the slewing gear is switched on

- **To switch on:** press button once – symbol flashes yellow
- **To execute:** move control lever for slewing gear, automatically:
 - slewing in position *Lift / lower counterweight*,
 - lower counterweight,

Move control lever for slewing gear in indicated direction, automatically:

- slewing in position *Move lifting cylinders*,
- retract lifting cylinders,

Automatic mode ends – symbol yellow

▣▣▣▣ p. 13 - 75

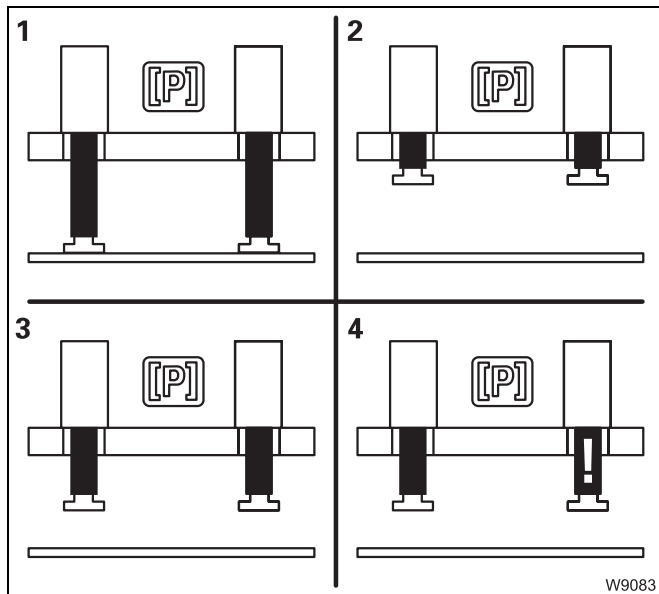

Lifting cylinder position display

The current status of the counterweight lifting cylinders is shown by different symbols:

- 1 Green – extended
- 2 Green – retracted
- 3 Yellow – intermediate position
- 4 Violet – error

➡ p. 13 - 73

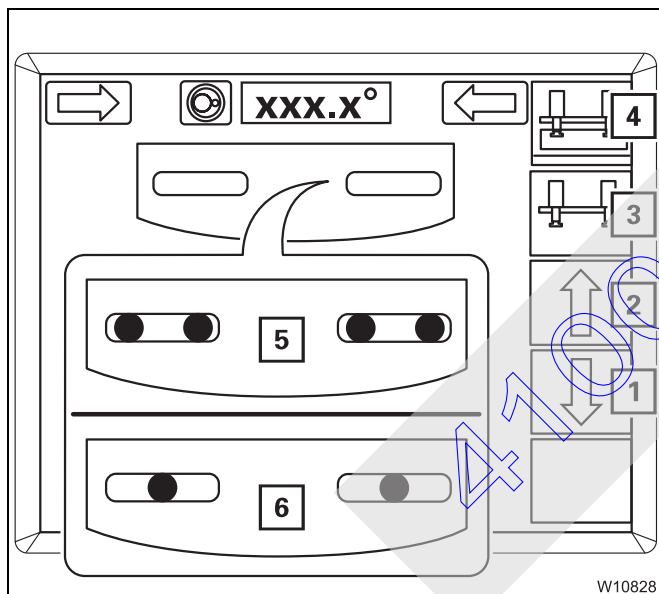

Extending / Retracting the lifting cylinders

1 To extend:

- display (5) and symbol (3) yellow or
- display (6) and symbol (4) yellow

Press button – slewing is locked after extension

2 To retract:

Press button – after reaching the end position, the counterweight is pre-tensioned

The movement stops after the button is released, and when an end position is reached; ➡ p. 13 - 73.

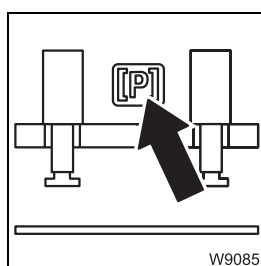

Pre-tensioning pressure display

- Green: pre-tensioning pressure reached
- Red: pre-tensioning pressure too low – pre-tension counterweight

➡ p. 13 - 74



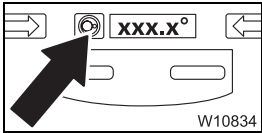

Slewing gear display

Identical with the display in the *Slewing gear / Houselock* submenu;
p. 10 - 72.

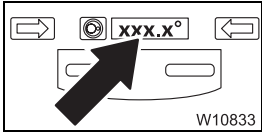

Current slewing angle display

Identical with the display in the *Slewing gear / Houselock* submenu;
p. 10 - 72.

10.2.12

Main hoist

Main hoist, p. 12 - 45.

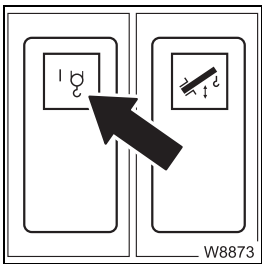

Main hoist on / off

There is an indicator lamp in the button.

- Press once – lamp bright – main hoist on
- lamp dim – main hoist off

p. 12 - 46

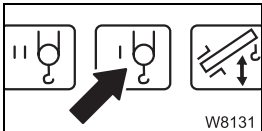

Power units display

- Green: main hoist on
- Red: main hoist off

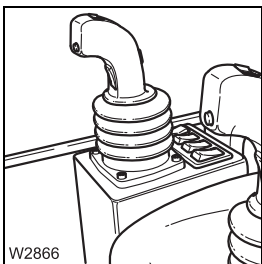

Right-hand control lever

- To the rear: lifting
- To the front: lowering

p. 12 - 46

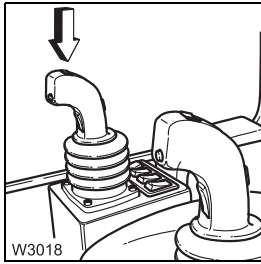

Hoist high-speed mode on / off

The parking brake is engaged.

- **Left:** high-speed mode on, off after releasing
- **Once to the right:** high-speed mode on – continuous operation
- **Once to the right or once to the left:** high-speed mode off

▣▣▣▶ p. 12 - 87

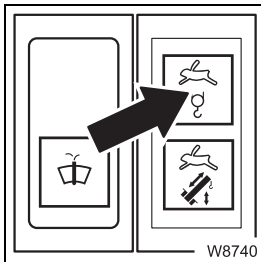

High speed indicator lamp for the hoists

- **On:** high-speed mode on
- **Off:** high-speed mode off

▣▣▣▶ p. 12 - 87

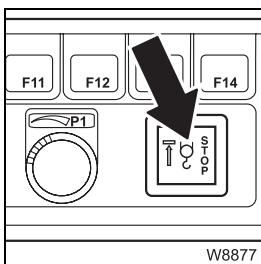

Warning lamp for lifting limit switch shutdown

- **On:** lifting limit switch triggered – hoist stops
- **Flashing:** lifting limit switch triggered – shutdown overridden
- **Off:** lifting limit switch not triggered

▣▣▣▶ p. 12 - 51

10.2.13

Auxiliary hoist

▣▣▣▣▶ *Auxiliary hoist*, p. 12 - 48.

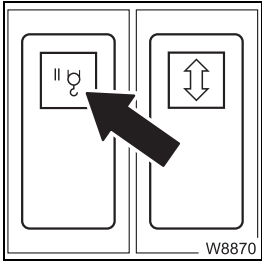

Auxiliary hoist on / off

There is an indicator lamp in the button.

- **Press once** - lamp bright – auxiliary hoist on
- lamp dim – auxiliary hoist off

▣▣▣▣▶ p. 12 - 48

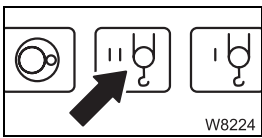

Power units display

- **Green:** auxiliary hoist on
- **Red:** auxiliary hoist off

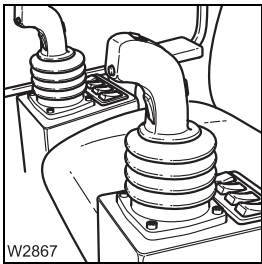

Left-hand control lever

- **To the rear:** lifting
- **To the front:** lowering

▣▣▣▣▶ p. 12 - 49

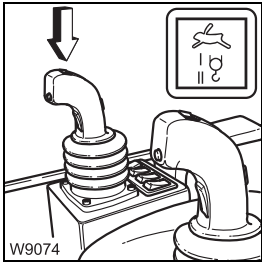

Button and lamp for hoist high-speed mode

Short description with main hoist, ▣▣▣▣▶ p. 10 - 69

Warning lamp for lifting limit switch shutdown

Short description with main hoist

10.2.14

Slewing gear

▣▣▣▣ ➔ *Slewing gear*, p. 12 - 88.

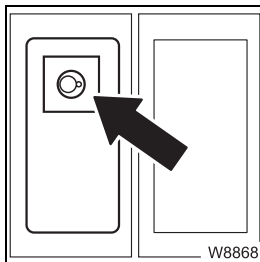

Slewing gear on / off

There is an indicator lamp in the button.

- **Press once**
- lamp bright – slewing gear on
slewing gear brake released
- lamp dim – slewing gear off
slewing gear brake engaged

▣▣▣▣ ➔ p. 12 - 88

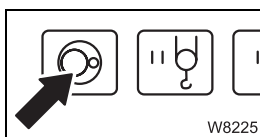

Power units display

- **Green:** slewing gear on
- **Red:** slewing gear off

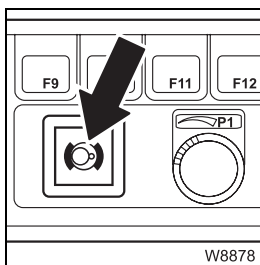

Slewing gear brake engaged / released

- **On:** slewing gear brake engaged
- **Off:** slewing gear brake released

▣▣▣▣ ➔ p. 12 - 88

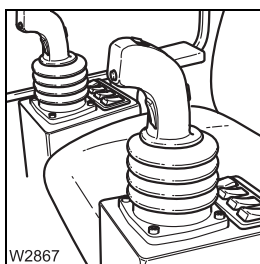

Left-hand control lever

The counterweight lifting cylinders are retracted.

- **To the left:** slewing to the left
- **To the right:** slewing to the right

▣▣▣▣ ➔ p. 12 - 88

Submenu

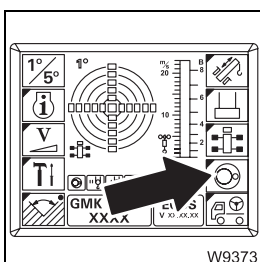

Slewing gear / Houselock submenu

- **To open:** press button once – submenu opens



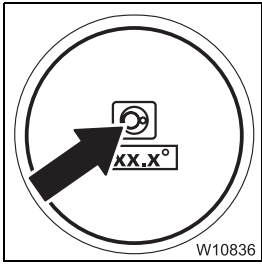

Slewing gear display

- **Green:** slewing gear switched on
 - **Red:** slewing gear switched off
- ➡ p. 12 - 88

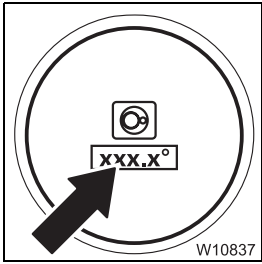

Current slewing angle display

- 0°:** Position *0° to the rear* – locking point
 - 180°:** Position *180° to the front* – locking point
 - + 0.1 to +180.0°:** Turned to the right from 0°
 - 0.1 to -179.9°:** Turned to the left from 0°
- ➡ p. 12 - 90

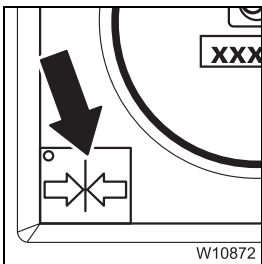

Stop at 0° / 180°

- **To switch on:** Press button until the dot turns **green**.
 When 0° or 180° is reached:
 - automatic slewing stop
 - slewing gear brake engaged
 - slewing blocked
 - **To switch off:** Press button until the dot turns **black**.
 - slewing enabled
 After switching on the ignition, the dot is black
- ➡ p. 12 - 90

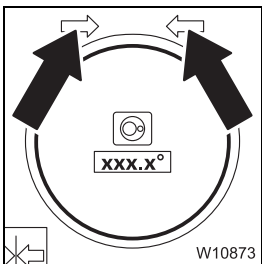

Display of slewing direction to 0° / 180°

- Current position $\pm 20^\circ$ in front of the 0° or 180° superstructure position.
- **Both arrows:** 0° or 180° superstructure position reached
 - **One arrow:** Arrow direction = slewing direction to reach 0° or 180°
- ➡ p. 12 - 90

10.2.15 Derricking gear

☛☛☛ Derricking gear, p. 12 - 54.

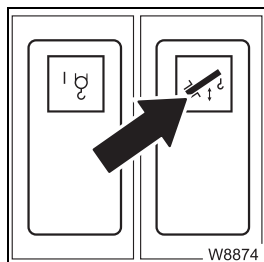

Derricking gear on / off

There is an indicator lamp in the button.

- **Press once**
- Lamp bright – derricking gear on
- power units with the same control lever assignment off
- Lamp dim – derricking gear off

☛☛☛ p. 12 - 54

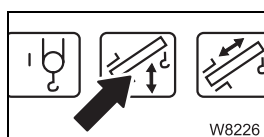

Power units display

- **Green:** derricking gear on
- **Red:** derricking gear off

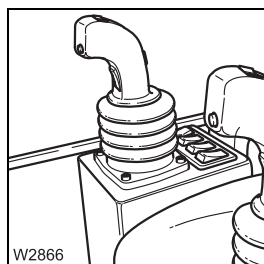

Right-hand control lever

- **To the left:** raise – lift main boom
- **To the right:** lower – lower main boom

☛☛☛ p. 12 - 55

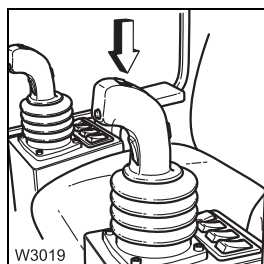

Derricking gear / Telescoping mechanism high-speed mode on / off

The parking brake is engaged.

- **Left:** high-speed mode on, off after releasing
- **Once to the right:** high-speed mode on – continuous operation
- **Once to the right or once to the left:** high-speed mode off

☛☛☛ p. 12 - 86

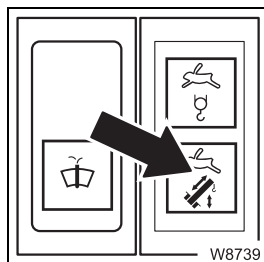

High-speed indicator lamp for derricking gear / telescoping mechanism

- **On:** high-speed mode on
- **Off:** high-speed mode off

☛☛☛ p. 12 - 86

10.2.16

Telescoping mechanism

Control panels

▣▣▣▣▣ *Telescoping mechanism*, p. 12 - 57.

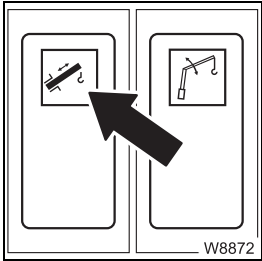

Telescoping mechanism on / off

There is an indicator lamp in the button.

- **Press once**
- Lamp bright – telescoping mechanism on, power units with the same control lever assignment off
- Lamp dim – telescoping mechanism off

▣▣▣▣▣ p. 12 - 65



Power units display

- **Green:** telescoping mechanism on
- **Red:** telescoping mechanism off

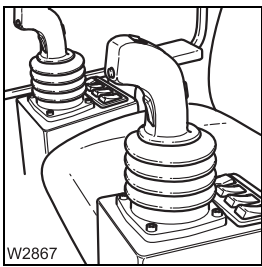

Left-hand control lever

Control lever assignment – version 1

- **To the rear:** retracting
- **To the front:** extending

▣▣▣▣▣ p. 12 - 65

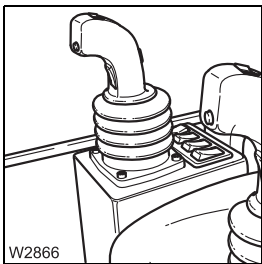

Right-hand control lever

Control lever assignment – version 2

- **To the left:** retracting
- **To the right:** extending

▣▣▣▣▣ p. 12 - 65

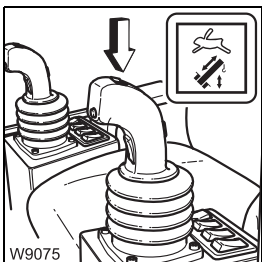

Button and lamp for derricking gear / telescoping mechanism high-speed mode

Short description with derricking gear; ▣▣▣▣▣ p. 10 - 73.

Submenu

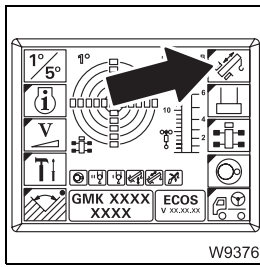

Telescoping submenu

- **To open:** press button once – submenu opens

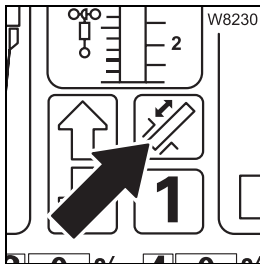

Display for telescoping mechanism on / off

- **Green:** telescoping mechanism on
- **Red:** telescoping mechanism off

➡ p. 12 - 68

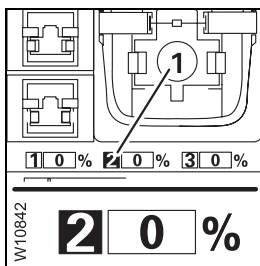

Current telescoping display

- 1 Extended length of the telescopic sections in percent (%)
- 2 Telescopic section display green

- **On:** telescoping cylinder is locked here
- **Flashing:** next possibility for locking telescoping cylinder

➡ p. 12 - 69

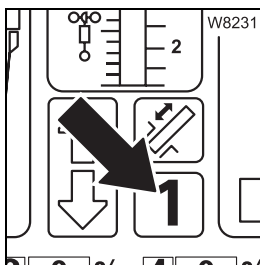

Display of telescoping cylinder in the telescopic section

Displayed telescopic section, e.g. telescopic section I:

- **On:** telescoping cylinder is locked here
- **Flashing:** next possibility for locking telescoping cylinder
- **Off:** telescoping cylinder in this telescopic section – distance to the locking point larger than 1 m (3.3 ft)
or
teleautomation on – symbol  is displayed

➡ p. 12 - 69



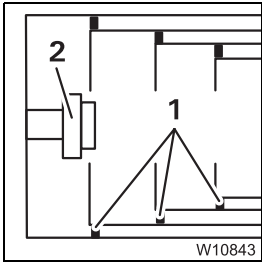

Telescope diagram display

Current relation of the telescopic sections to each other – section of top view

Locking pins

- 1 On the telescopic section
- 2 On the telescoping cylinder

Illustrations 1 and 2

- **Green:** locked
- **None:** unlocked or intermediate position

➡ p. 12 - 69

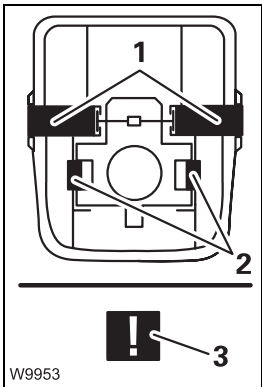

Locking status display

The locking pins change the position and the colour

Locking pins

- 1 On the telescopic section
- 2 On the telescoping cylinder

Illustrations 1 and 2

- **Green:** locked
- **Red:** unlocked
- **Yellow:** intermediate position
- **Violet:** error – symbol (3)

➡ p. 12 - 70

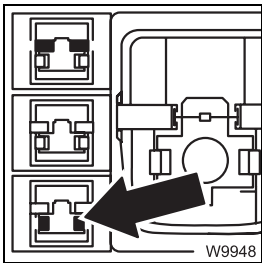

Select Unlock telescoping cylinder

- **Display**
 - Yellow:** telescoping cylinder unlocked
 - Grey:** telescoping cylinder locked
 - Flashing:** Unlock selected (yellow / grey)

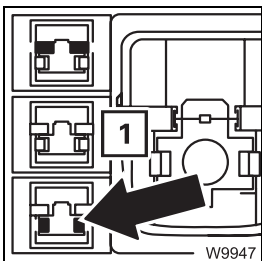

- **To select:** press button once
 - Telescopic section locked: Unlock selected – is executed after moving the control lever
 - Telescopic section unlocked: Unlock not selected – symbol (1) flashes (yellow / grey) as a prompt to *Lock telescopic section*

➡ p. 12 - 71

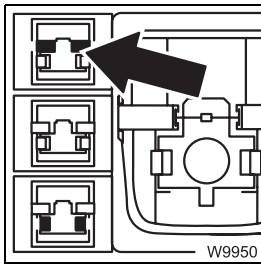

Select Unlock telescopic section

- **Display**
 - Yellow:** telescopic section unlocked
 - Grey:** telescopic section locked
 - Flashing:** Unlock selected (yellow / grey)

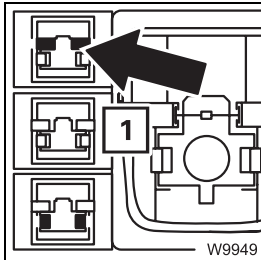

- **To select:** press button once
 - Telescoping cylinder locked:
Unlock selected – is executed after moving the control lever
 - Telescoping cylinder unlocked:
Unlock not selected – symbol (1) flashes (yellow / grey) as a prompt to *Lock telescoping cylinder*

➡ p. 12 - 75

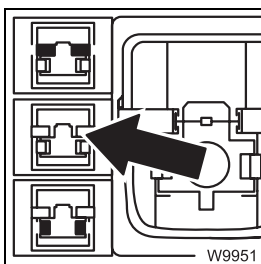

Select Lock

- **Display**
 - Yellow:** telescoping cylinder and telescopic section locked
 - Grey:** telescoping cylinder or telescopic section unlocked
 - Flashing:** Lock selected (yellow / grey)

➡ p. 12 - 74, ➡ p. 12 - 78

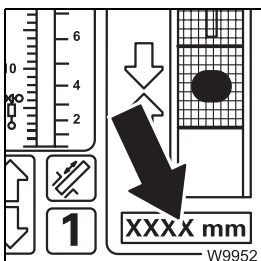

Telescoping cylinder length display

- **Display:** current extended length of the telescoping cylinder
- **Unit of measurement:** displayed depending on setting, mm (millimetres) or ft (feet)

➡ p. 12 - 73



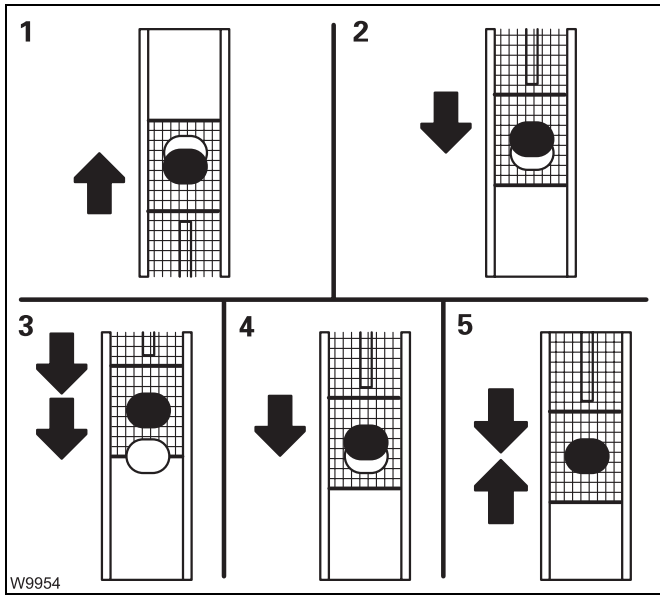

Locking point display

- Direction of travel to the locking point
- 1 Extend telescoping cylinder
- 2 Retract telescoping cylinder

- Distance to the locking point
- 3 Yellow: approx. 1 m (3.3 ft)
- 4 Yellow: smaller than 1 m (3.3 ft)
- 5 Green: at the locking point

W9954

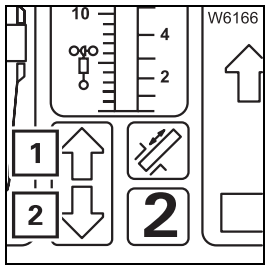

Display for releasing telescoping

- 1 Extending**
 - Red: blocked
 - Green: released
- 2 Retracting**
 - Red: blocked
 - Green: released

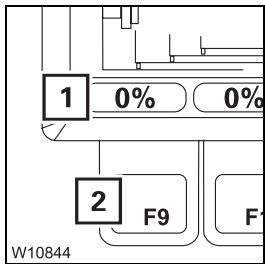

Entering the nominal value for teleautomation

- 1 - Red:** teleautomation off
- **Yellow:** enter nominal value
- **Green:** teleautomation on
- 2** Press button first time – nominal value input on
- Press button once – nominal value to next fixed length

W10844

▶ p. 12 - 80

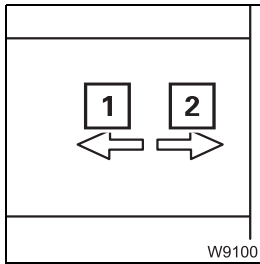

Teleautomation direction display

- 1 On:** start teleautomation with *Extending*
- 2 On:** start teleautomation with *Retracting*

Flashing = control lever movement not correct
 p. 12 - 81

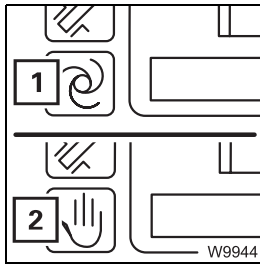

Teleautomation on / off display

- 1** Teleautomation on
- 2** Teleautomation off

 p. 12 - 80

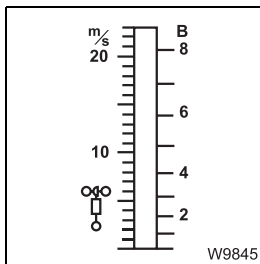

Anemometer display

Same as in the main menu;  p. 10 - 64.

In the settings submenu

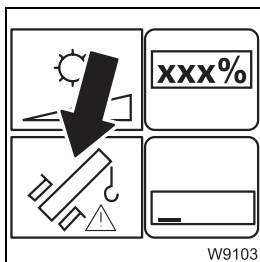

Telescoping emergency program access

Right-hand dead man's switch is pressed.

- **Press button once:** after entering the keycode, the emergency program opens *Telescoping*

 p. 15 - 39



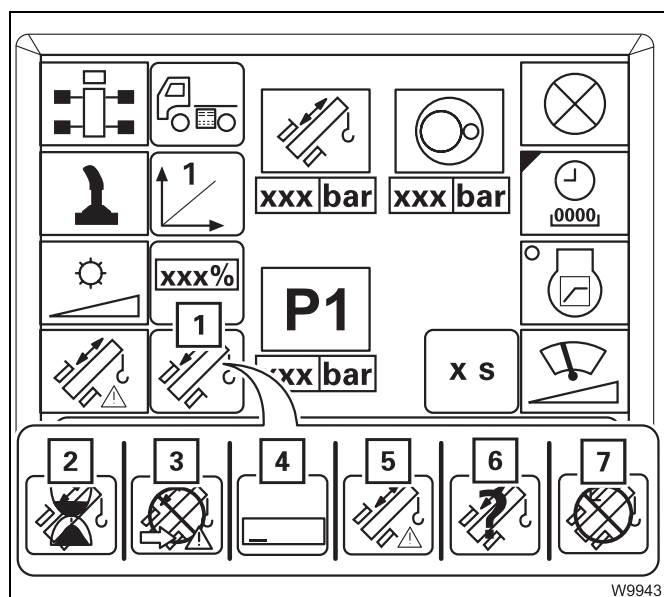

Current telescoping mechanism status display

The current status is shown using different symbols:

- 1 Normal
- 2 Waiting
- 3 Emergency program access
- 4 Keycode input
- 5 Emergency program
- 6 Telescope status divergence
- 7 Not active

▣ p. 15 - 18

41005067

10.2.17 Hydraulic system

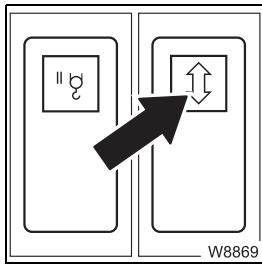

Inclining the crane cab

- Press down: incline to the rear
 - Press up: incline to the front
- ➡ p. 12 - 95

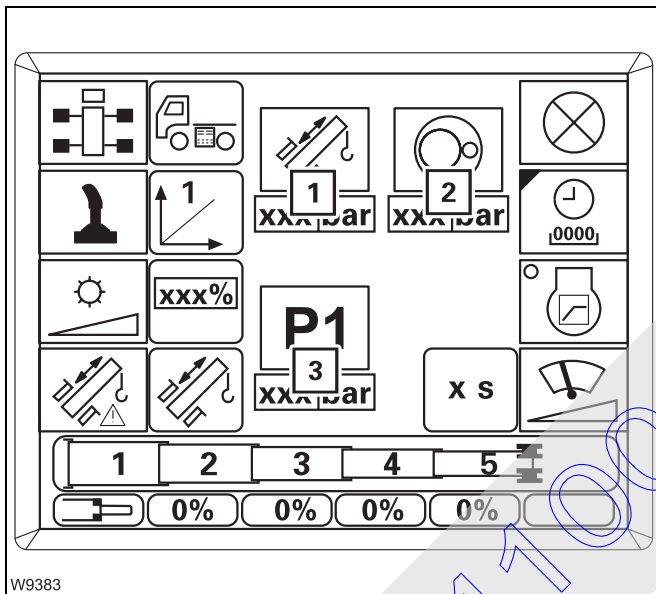

In the settings submenu

Current pressure in bar for movements of the

- 1 Telescoping mechanism
- 2 Slewing gear
- 3 - hoist
- derricking gear
- counterweight hoist unit
- incline cab
- locking units

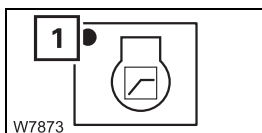

Critical load control

- To switch on: press button until the dot (1) turns green.
 - To switch off: press button until the dot (1) turns black.
- ➡ p. 12 - 99

10.2.18

Houselock

▮▮▮▮ ➔ *Switching the houselock on / off*, p. 12 - 14.

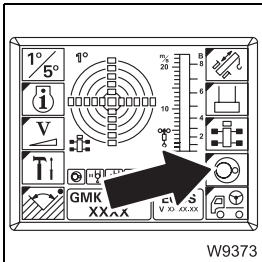

Slewing gear / Houselock submenu

- **To open:** press button once – submenu opens

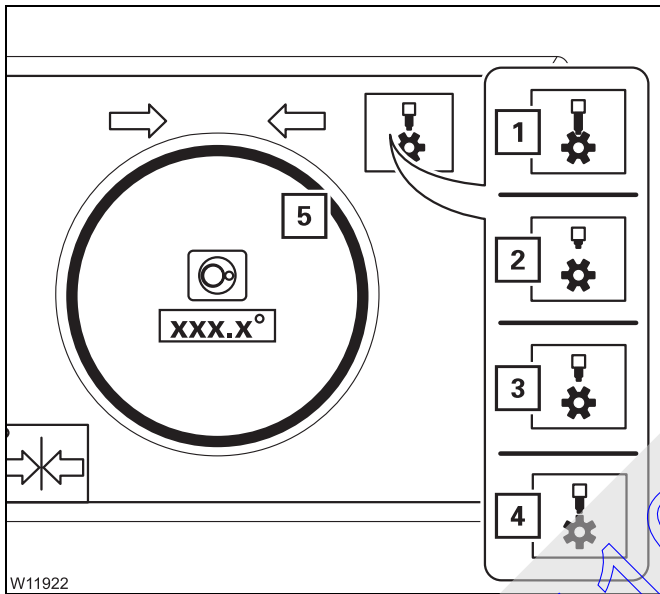

Locking status displays

The current status of the locking pin is shown by different symbols:

- 1 and 5** Green – locked
- 2 and 5** Red – unlocked
- 3 and 5** Yellow – intermediate position
- 4 and 5** Yellow / red – blocked, locking pin in front of a tooth

▮▮▮▮ ➔ p. 12 - 14

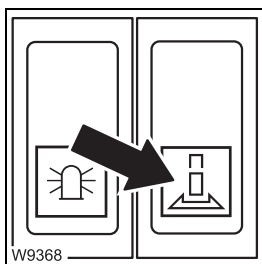

Houselock on / off

The slewing gear is switched off

- **Press up:** switch on – pin extends
- **Press down:** switch off – pin retracts

▮▮▮▮ ➔ p. 12 - 14

10.2.19 Safe load indicator (SLI)

Input elements with displays

▣▣▣▣ Operation of the safe load indicator, p. 12 - 17.

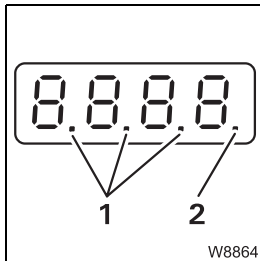

Displays

Display – maximum of four digits

- 1 Point for decimal places
- 2 Signalling point

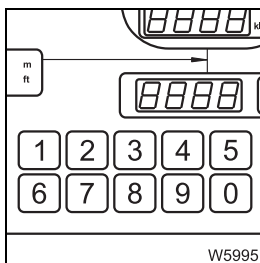

Numerical pad

- **Buttons 1 to 0:**
 - enter SLI code, reeving
 - date / time display
- **Additional functions:**
 - enter date / time
 - lamp test



Additional function F1 on

Use always in combination with other buttons:

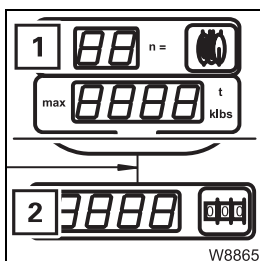

- Reeving input mode

Press **F1** button and additionally press button once – display (1) flashes – input mode on

- SLI code input mode

Press **F1** button and additionally press button once – display (2) flashes – input mode on

▣▣▣▣ p. 12 - 21

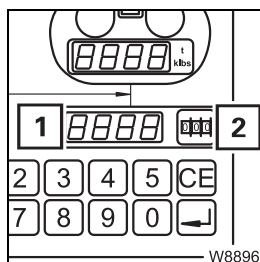

SLI code display and input

- 1 **Display:** SLI code, four digits
- 2 **Enter:** In input mode
 - press button once – next SLI code
 - or enter via numerical pad

▣▣▣▣ p. 12 - 22



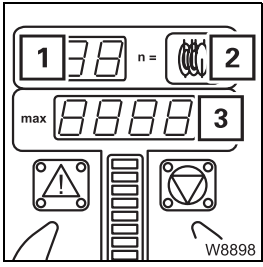

Reeving display and input

- 1 Display:** required quantity of reeved ropes for maximum load (**3**)
- 2 Enter:** in input mode
 - press button  once – quantity +1
 - or enter via numerical pad

▣▣▣▣▶ p. 12 - 25

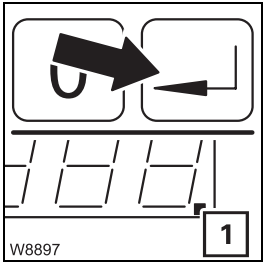

Confirming an entry

- **Press button once:** input mode off
 - signalling point (**1**) is displayed
 - value not flashing anymore



Acknowledge

- **Press button once:** buzzer tone off, error message acknowledged or time input aborted

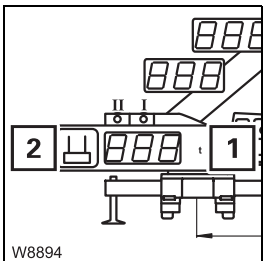

Counterweight display and input

- 1 Display:** counterweight combination in tons (t) – for displayed SLI code
- 2 Enter:** in input mode
 - press button  once – next combination

▣▣▣▣▶ p. 12 - 26

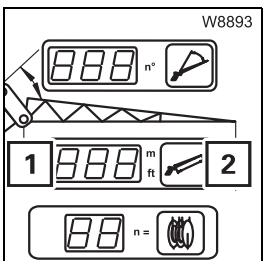

Lattice extension length display and input

- 1 Display:** lattice extension length in metres (m) or feet (ft) – for displayed SLI code
- 2 Enter:** in input mode
 - press button  once – next length

▣▣▣▣▶ p. 12 - 26

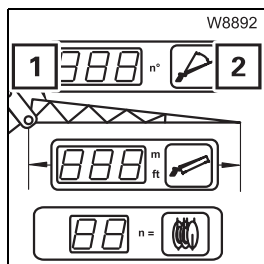

Lattice extension angle display and input

An SLI code for the inclinable lattice extension is displayed.

- 1 Display:** angle between lattice extension and main boom in degrees (°) – for displayed SLI code
- 2 Enter:** in input mode
press  button once – next angle

➡ p. 12 - 26

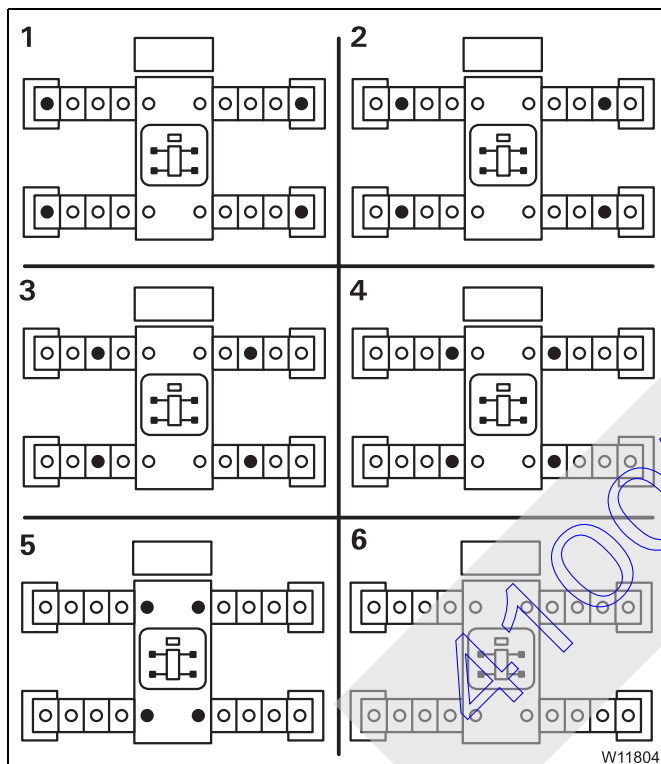

Outrigger span display and input

– Display

Required outrigger span for displayed SLI code

- 1** 8.332 x 7.00 m (27.3 x 23.0 ft)
- 2** 8.332 x 6.00 m (27.3 x 19.7 ft)
- 3** 8.332 x 5.00 m (27.3 x 16.4 ft)
- 4** 8.332 x 4.00 m (27.3 x 13.1 ft)
- 5** 8.332 x 2.54 m (27.3 x 8.4 ft)
- 6** Free on wheels

– Input

In input mode

Press button  once – next outrigger span

➡ p. 12 - 25

Display elements

➡ Displays during crane operation, p. 12 - 31

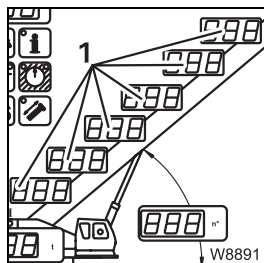

Current telescoping display

- 1** Telescoping of telescopic sections
 - fixed lengths as decimal values – two decimal places after the comma
 - intermediate lengths in percent
- Surplus displays have no function

➡ p. 12 - 31



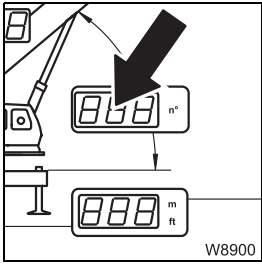

Current main boom angle display

Main boom angle in relation to horizontal position in degrees (°) – display of negative angles, e.g. -3°

➡ p. 12 - 31

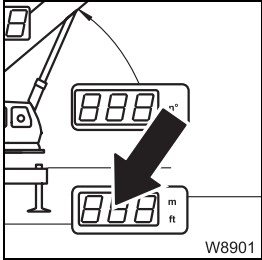

Current working radius display

Working radius in metres (m) or feet (ft) – without decimal place

➡ p. 12 - 31

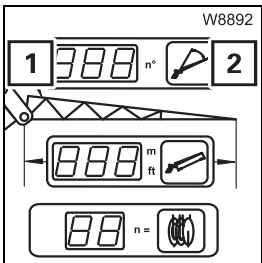

Current lattice extension inclination display

An SLI code for the derricking lattice extension is displayed.

- 1 Angle between the lattice extension and main boom in degrees (°)
- 2 Additional function:
 Press  once – display of current angle between lattice extension and horizontal position, for two seconds

➡ p. 12 - 31

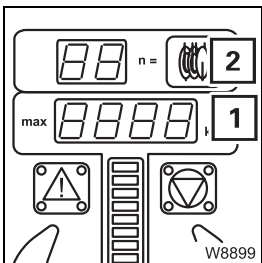

Maximum load display

- 1 Maximum load in tons (t) or kilopounds (klbs) for displayed SLI code – one decimal place
 (display: 55.2 klbs equal 55,200 lbs)
- 2 Special case – **max** and **n=** entries flash:
 Maximum load reduced by reeving –
 Press  once – display (1) of maximum possible load for displayed SLI code, for three seconds

➡ p. 12 - 31

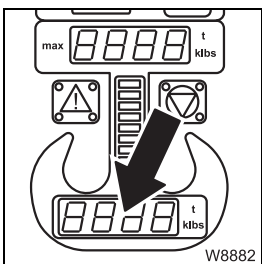

Current load display

Currently raised load in tons (t) or kilopounds (klbs) – precision ± 5% of actual load

Signalling point behind the value = shutdown

➡ p. 12 - 31

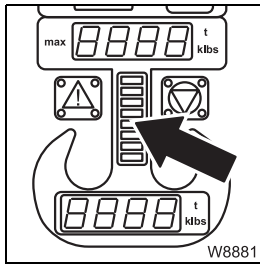

Current degree of utilization display

Degree of utilization = $100 \times \text{actual load} / \text{maximum load}$ –
Coloured lights for percentage ranges,

- **Green:** 0 – 90%
- **Yellow:** approx. 90 – 100% – early warning
- **Red:** greater than 100% – shutdown

▶▶▶▶ p. 12 - 31

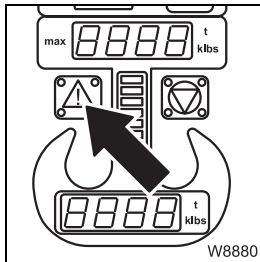

SLI early warning

- **Flashing:** degree of utilization 90 – 100% – buzzer tone on
- **On:** degree of utilization about 100% – buzzer tone on – shutdown
- **Off:** degree of utilization 0 – 90%

▶▶▶▶ p. 12 - 35

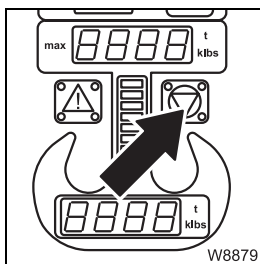

SLI shutdown

- **On:** shutdown – buzzer tone on
– degree of utilization about 100% or error
- **Off:** degree of utilization below 100%, no error

▶▶▶▶ p. 12 - 36

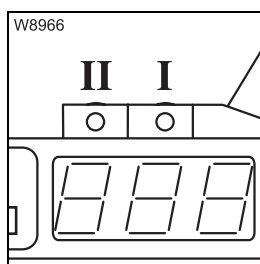

Hoists display

- **I on:** main hoist switched on first – displayed reeving applies to main hoist
- **II on:** auxiliary hoist switched on first – displayed reeving applies to auxiliary hoist
- **I or II flashing:** corresponding hoist switched on as well – displayed reeving applies to the other hoist
- **I or II off:** corresponding hoist switched off

▶▶▶▶ p. 12 - 30





Additional function F2 on

Use always in combination with other buttons:

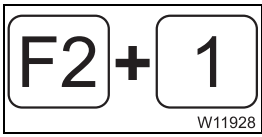

- Lamp test

Press **F2** and additionally press **1** once – all the lamps go on for two seconds

▣▣▣▣▶ p. 12 - 21

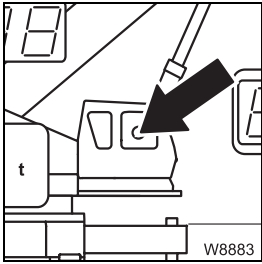

Sensor for brightness

Registers the brightness of the operating environment. The brightness of all displays is automatically adjusted; ▣▣▣▣▶ p. 12 - 20.



F3 and F4 service buttons

For access to the service software, with connected service device.

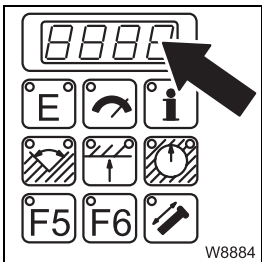

Information / error display

Press the required button on the display once – lamp in button on – corresponding value appears on display.

▣▣▣▣▶ p. 12 - 33

On the front panel

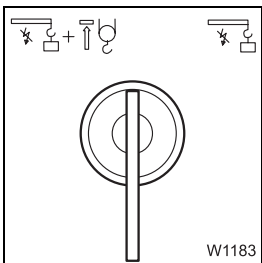

Key-operated override switch

- **Turn to the right:** *SLI* shutdown overridden – crane functions released, no more monitoring; ▣▣▣▣▶ p. 12 - 38
- **Turn to the left:** *SLI* shutdown and *Lifting limit switch* shutdown overridden – crane functions released, no more monitoring; ▣▣▣▣▶ p. 12 - 52.

10.2.20

Electrical system

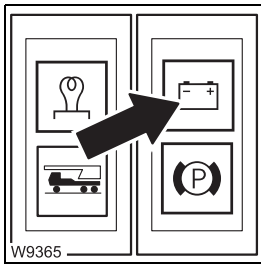

Voltage warning lamp

- **On:** engine off – ignition on
or
engine on – power failure – switch off engine
- **Off:** engine on – no malfunction

▶▶▶▶▶ p. 11 - 7

10.2.21

Lighting, windscreen wiper / washing system

Lighting

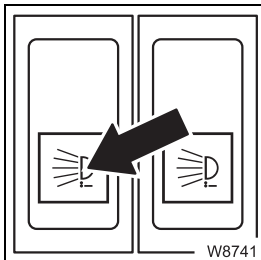

Spotlight sockets on / off

- **To switch on:** press down – voltage on (both sockets)
- **To switch off:** press up – voltage off (both sockets)

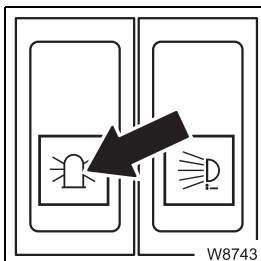

Air traffic control light on / off

- **To switch on:** press down – voltage on socket switched on
- **To switch off:** press up – voltage on socket switched off

▶▶▶▶▶ p. 13 - 108

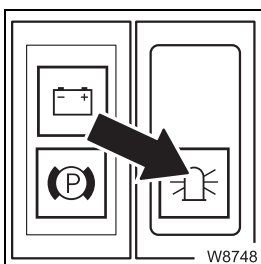

Rotating beacon on / off

- **To switch on:** press down – lamp in button on
- **To switch off:** press up – lamp in button off



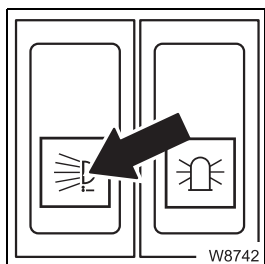

Sleuable spotlight on / off

- **To switch on:** press down
 - **To switch off:** press up
- ▣▣▣▣ p. 12 - 100

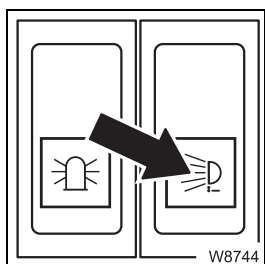

Directing the spotlights

- **To the rear:** press down
 - **To the front:** press up
- ▣▣▣▣ p. 12 - 100

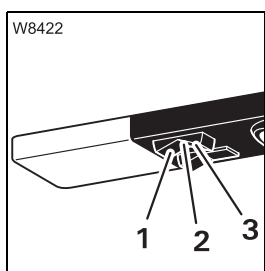

Cab lighting

- 1 Permanently on
- 2 Permanently off
- 3 On / off via door contact

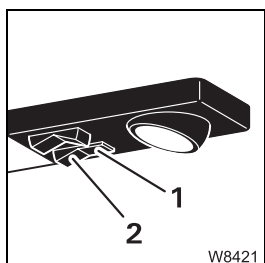

Reading lamp

- 1 On
- 2 Off

41005067

Windscreen wiper / washing system

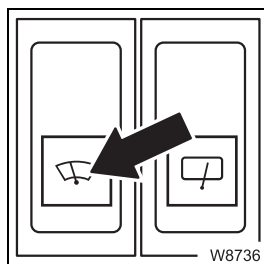

Front windscreen wiper on / off

- **Off:** press up – wiper goes to end position
- **Interval:** middle position
- **Continuous operation:** press down

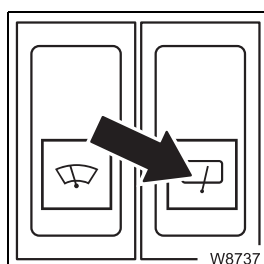

Roof window wiper on / off

- **Off:** press up – wiper goes to end position
- **Interval:** middle position
- **Continuous operation:** press down

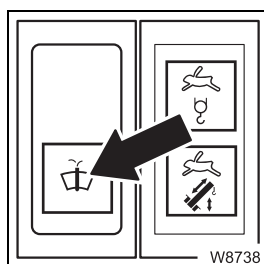

Windscreen washing system

- **Windscreen:** press down
 - **Skylight:** press up
- No additional wiping function is performed

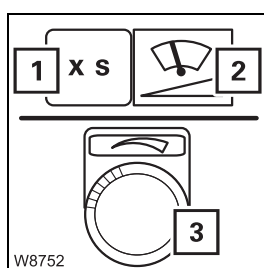

Adjusting the wiper stroke interval

In the *Settings* submenu

- 1 Display of interval
- 2 Press once – input mode on
- 3 Turn – change interval

▶▶▶▶▶ p. 12 - 96

10.2.22

Hand-held control

Sockets for hand-held control

The following applies to all sockets:

- Pull plug: engine off – ignition off
 - Insert plug: ignition on
- ➡ p. 13 - 20

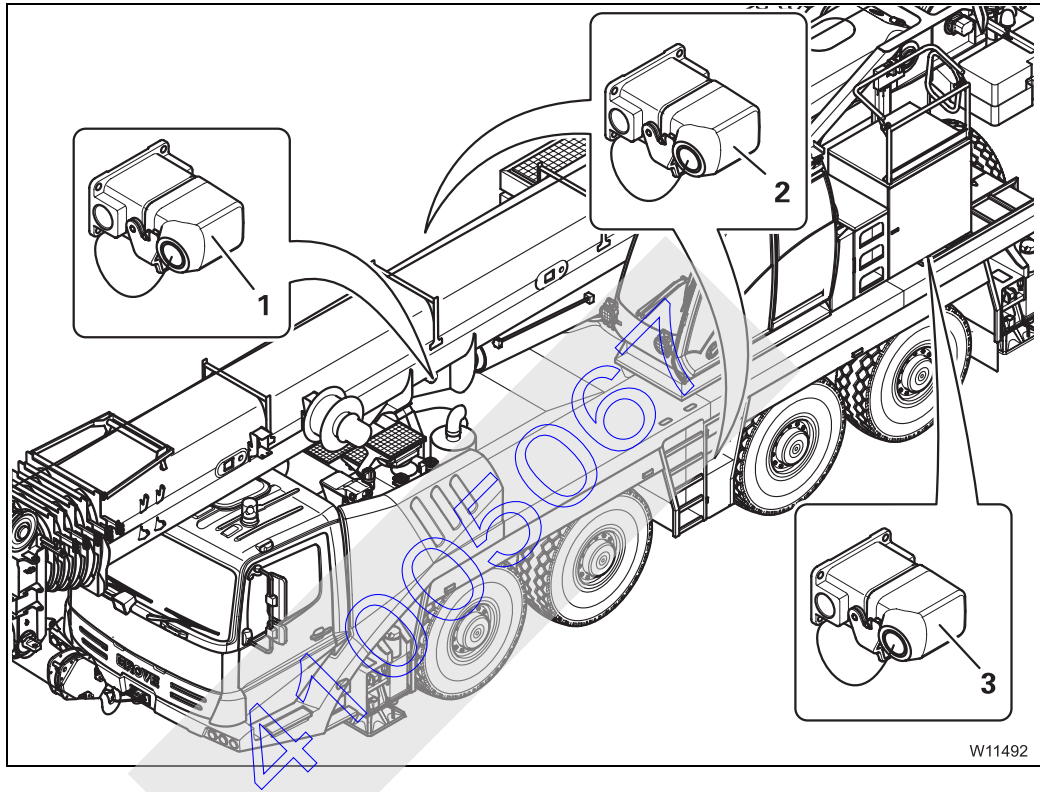

Enabled operations	
1	- Emergency operation for crane movements (except for telescoping mechanism) - Derrick lattice extension ¹⁾
2	- Operation of the outriggers
3	- Emergency mode for crane operations - Derrick lattice extension ¹⁾

¹⁾ Lattice extension – derricking

Engine control panel

▶▶▶ Starting the engine – with the hand-held control, p. 11 - 17

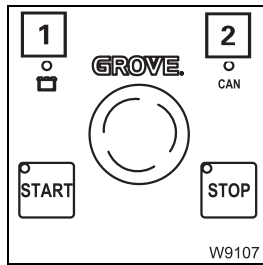

1 Voltage indicator lamp

- On: ignition on
- Off: ignition off

2 CAN indicator lamp

- On: hand-held control connected – no malfunction – goes out after 20 seconds
- Flashing: **hand-held control connected – malfunction**

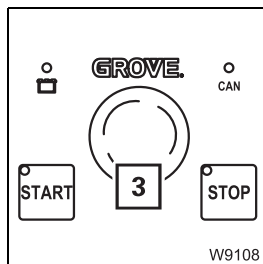

3 Emergency stop switch

May be actuated in an emergency only

- Press: engine off – crane functions stop immediately, switch engages
- Turn engaged switch: switch returns to initial position – crane functions released

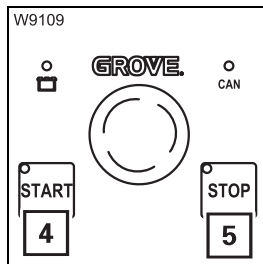

4 START engine

- Press once: engine on

5 STOP engine

- Press once: engine off

Horn

The ignition is switched on.

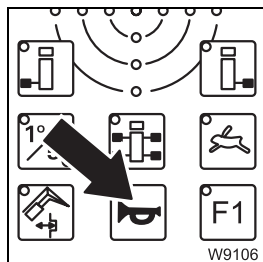

- Press once:
 - hand-held control on the superstructure socket – superstructure horn on
 - hand-held control on the carrier socket – carrier horn on



Outriggers control panel

Brief description;  *Outriggers control panel*, p. 10 - 45.

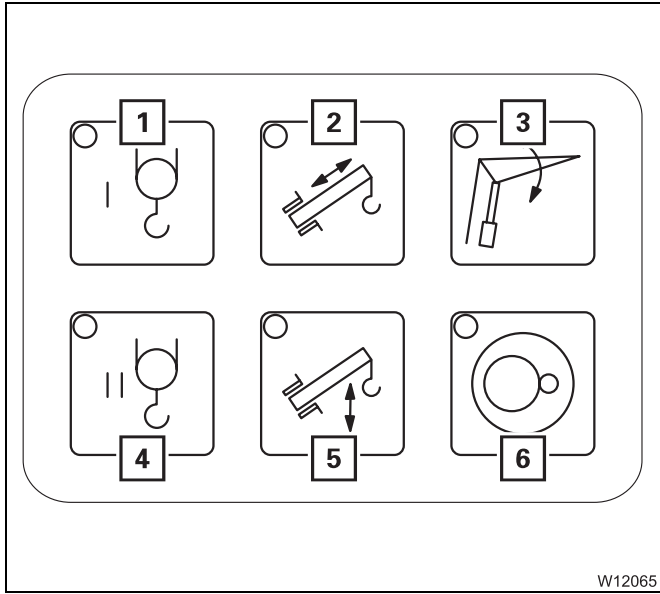

Pre-select emergency operation

- 1 Main hoist
- 2 Telescoping mechanism
- 3 Derrick lattice extension¹⁾
- 4 Auxiliary hoist
- 5 Derricking gear
- 6 Slewing gear

¹⁾ Lattice extension – derricking

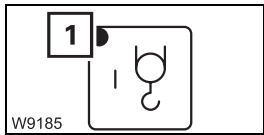

Actuation is the same for all buttons

- **Pre-select:** press button once – lamp (1) lights up – pre-selection on until other pre-selection is made

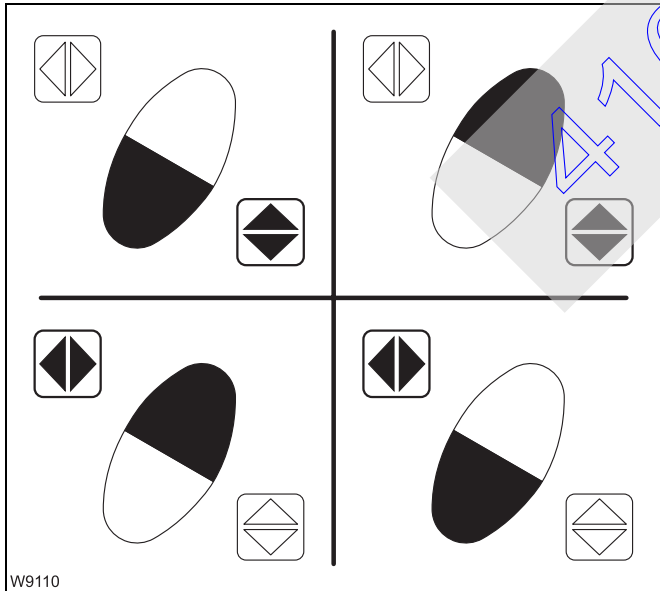

Function buttons

The operations are not monitored by the SLI.







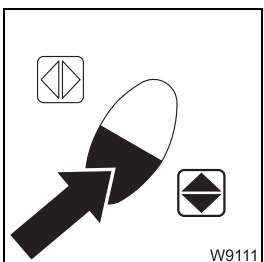

There are four button combinations, actuated buttons are shown in black:

- **Pre-selected function on**
Press required button combination.
- **Pre-selected function off**
Release one or both of the buttons.

Press a non-assigned button combination – pre-selection off.

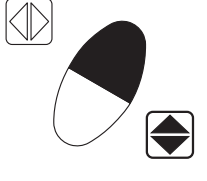
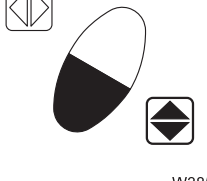
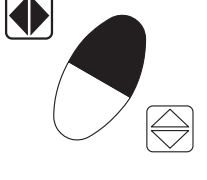

- **Faster movement:** press button harder
- **Slower movement:** press button less hard

Button combination	Pre-selected power unit					
	Telescoping mechanism 	Derricking gear 	Slewing gear 	Hoists  		Lattice extension 
 W3851	none	lower	none	lower		lower
 W3850	retract	raise	none	lift		raise
 W3849	none	none	slew to right	none		none
 W3848	none	none	slew to the left	none		none

Emergency operation with the hand-held control, p. 15 - 51

10.2.23 Diagnostics

The diagnostics connections may only be operated by the service staff.

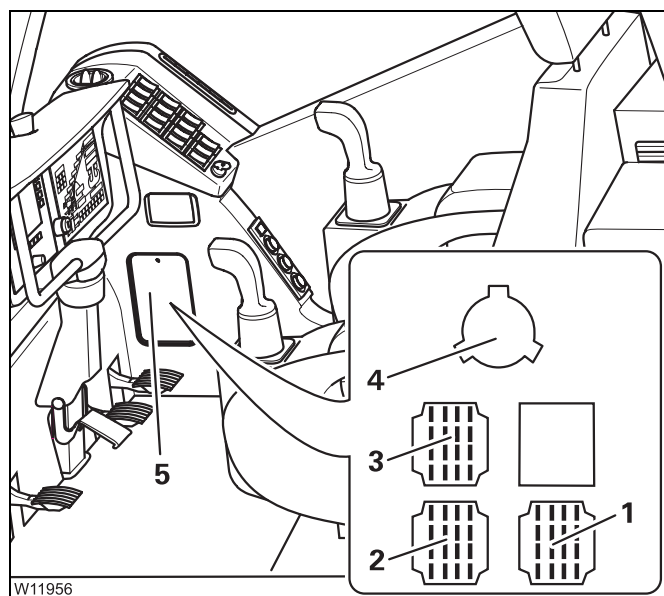

The following connections are below the cover (5).

- 1 ECOS diagnostics – (serial interface)
- 2 ECOS diagnostics – Can bus
- 3 SLI diagnostics
- 4 Engine diagnostics

41005067

10.2.24 Windows, doors, keys

Windows

The handles on the windscreen and the rear window have the same function.

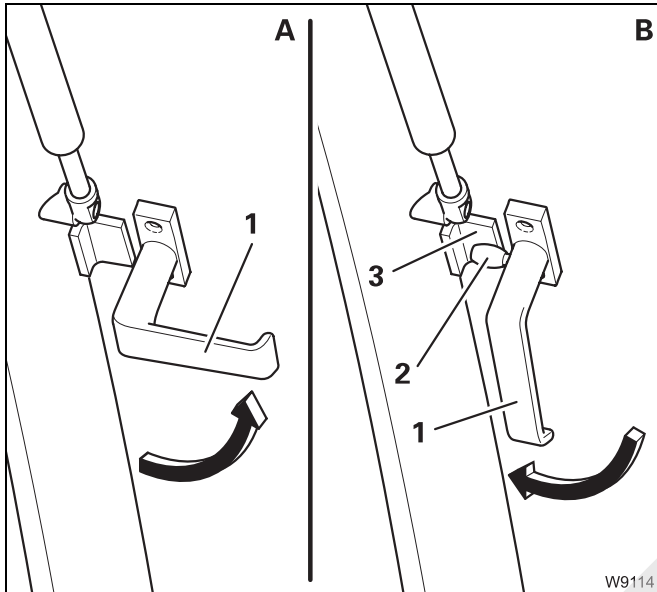

Open window (A)

- Turn both handles (1) inwards
- Push window forward

Close window (B)

- Pull window in
- Turn both handles down – pegs (2) located behind the holder (3)

Crane cab door

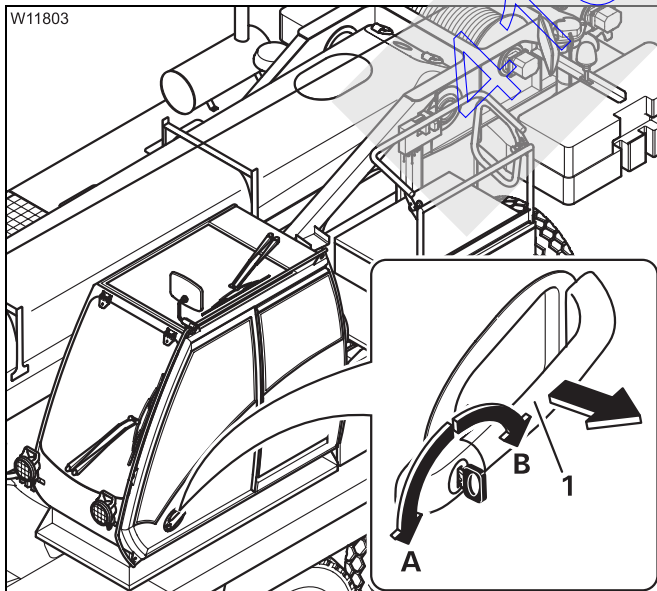

From outside

Unlock

- Turn the key in direction A

Lock

- Turn the key in direction B

Open / Close

- Pull the handle (1).
- Push the door



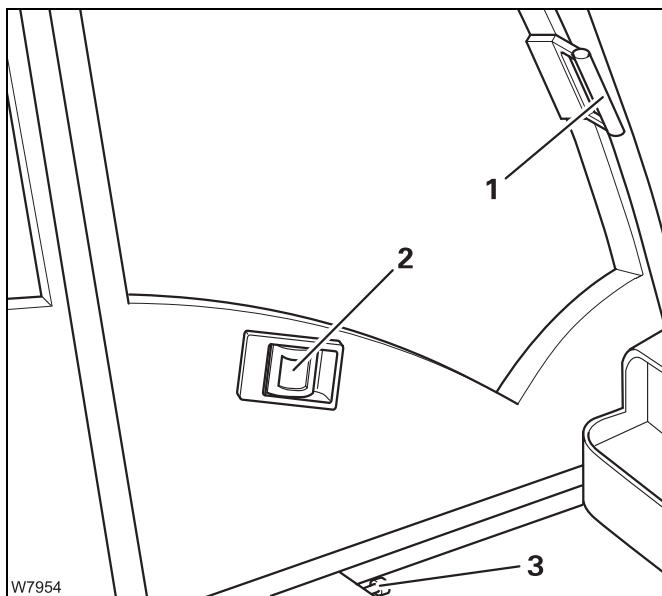

From inside

- **Close**
 Pull unlocking lever (3), push door forwards by handle (1) – engages.
 Locking from inside not possible.
- **Open**
 Pull unlocking lever (2), push door back by handle (1) – engages.

Keys

Different keys are supplied.

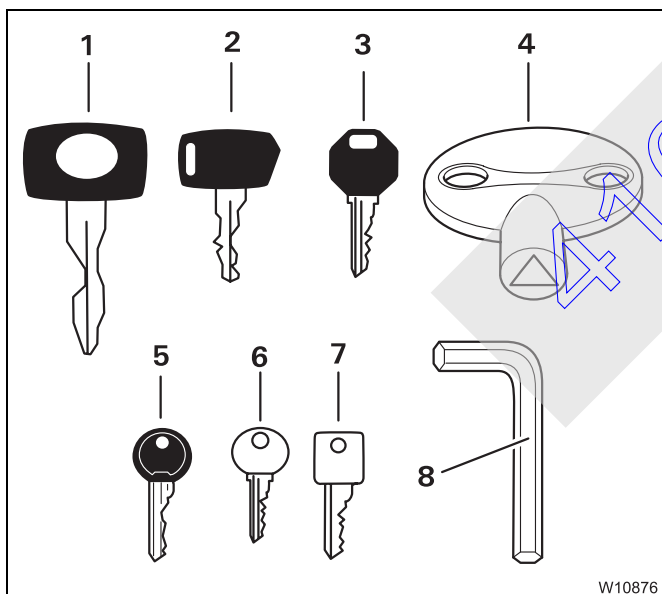

- 1 Crane cab door lock
 - 2 Crane cab ignition lock
 - 3 Key-operated override switch
 - 4 Distribution box
 - 5 Windscreen washing system reservoir
 - 6 Boom floating position lock¹⁾
 - 7 Slewing gear freewheel lock¹⁾
 - 8 Covers
- ¹⁾ Additional equipment

10.3

Short description of the operating elements – driving from the crane cab

10.3.1

Driving submenu

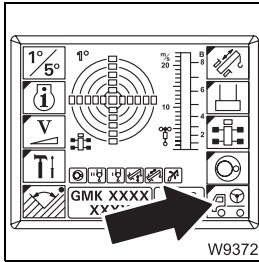



Driving submenu

- **To open:**
 - **Manually**
press button once – submenu opens
 - **Automatically**
Driver's cab: ignition key in position **1**
Crane cab: ignition on – submenu opens;
- **Close**
Crane cab: ignition off,
press button  once – main menu opens

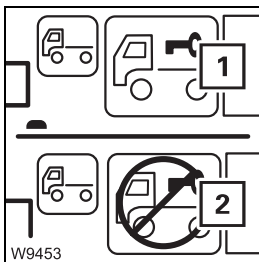
➡ p. 14 - 8



Steering lock display

- 1 Green:** Driver's cab: ignition key in position **1**
Crane cab: operating elements for driving active if carrier ignition is switched on
- 1 Red:** Driver's cab: ignition key not in position **1**
Crane cab: operating elements for driving without function
- 2 Red:** Crane cab: operating elements for driving without function, possible causes:
 - supply pressure in secondary consumers too low – warning 
 - parking brake was released before the submenu was opened
 - impermissible shifting operation, e.g. accelerator and brake pedal actuated simultaneously
 - tachograph malfunction – warning 

➡ p. 14 - 8

10.3.2

Engine for driving

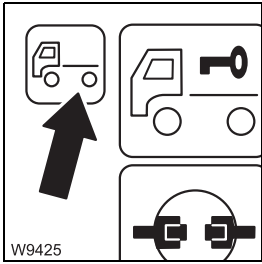

Carrier ignition display

- **Red:** ignition off – engine start not possible
- **Green:** ignition on – engine start possible

➡ p. 14 - 8

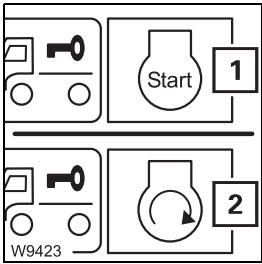

Start engine for driving

The carrier ignition is switched on.

- 1 Starting the engine:** press button 1 once – motor starts
- 2 Motor running:** switch off engine – carrier ignition off;

➡ p. 14 - 8

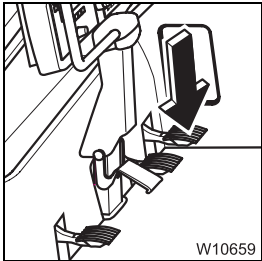

Accelerator

- **Carrier ignition on:** regulates the engine speed for driving
- **Carrier ignition off:** regulates the engine speed for crane operation

➡ p. 14 - 8

10.3.3**Transmission**

▣▣▣▣► *Operating the transmission*, p. 14 - 15.

The following applies to all operating elements:

- the *Driving mode* submenu opened automatically
- the *Service brake* pedal is actuated
- the truck crane is stationary

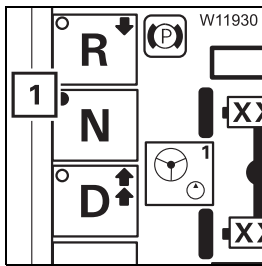
**Neutral position N**

- **To switch on:** press button once – dot (1) green - no gear engaged
- **To switch off:** switch to (D) or R – dot (1) black

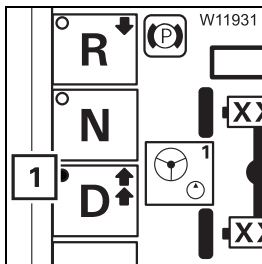
**Transmission mode D**

- **To switch on:** press button once – dot (1) green - second gear engaged as a full gear
- **To switch off:** switch to (R) or N – dot (1) black

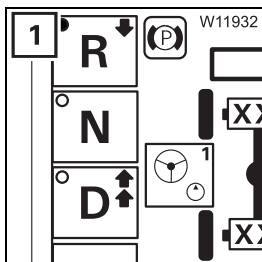
**Transmission mode R**

- **To switch on:** press button once – dot (1) green - first reverse gear engaged
- **To switch off:** switch to (D) or N – dot (1) black

10.3.4

Final drive

▮▮▮▮ *Longitudinal / transverse differential locks, p. 14 - 20*

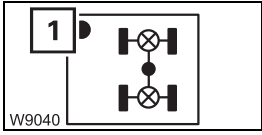

Transverse differential locks on / off

- **To switch on:** press button once – dot (1) green
- **To switch off:** press button once – dot (1) black

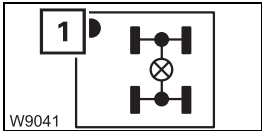

Longitudinal differential locks on / off

- **To switch on:** press button once – dot (1) green
- **To switch off:** press button once – dot (1) black

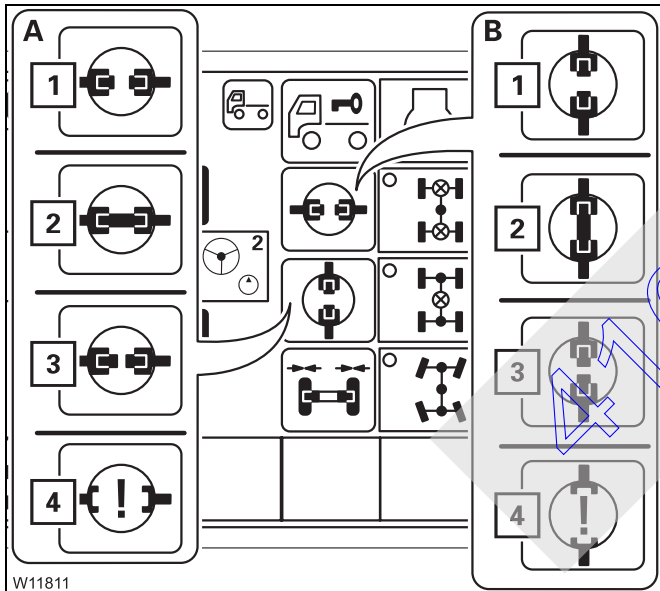

A Transverse differential locks display
B Longitudinal differential locks display

The current status is shown using different symbols:

- 1 Green – locks off
- 2 Red – locks on
- 3 Yellow – intermediate position
- 4 Violet – error

10.3.5

Brakes

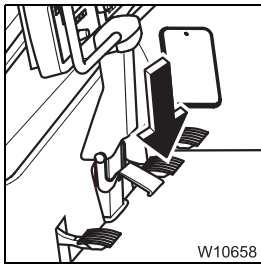

Service brake brake pedal

Affects the carrier brakes – the braking force can be continuously adjusted.

Side panel

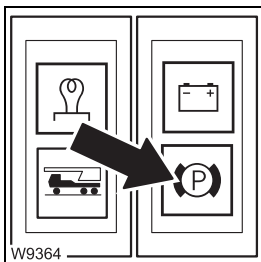

Parking brake indicator lamp

- On: parking brake engaged
- Off: parking brake released

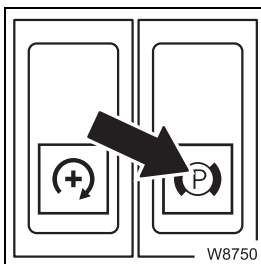

Applying / releasing parking brake

- Press up once: release parking brake
 - Press down once: apply parking brake
- ➡ After driving, p. 14 - 21.

ECOS display

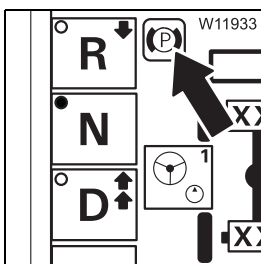

Parking brake display

Shows the selected gear change

- Red: apply parking brake
- Grey: release parking brake

There is no short description of the displays in the *Warning* submenu;
➡ *Warning submenu*, p. 12 - 102.

10.3.6

Steering

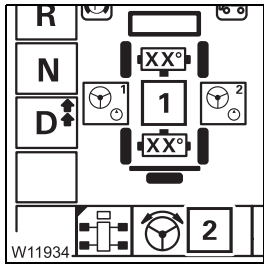

Changing the steering direction

– **To switch:** press button (2) – symbol in display (1) changes – corresponding steering direction on

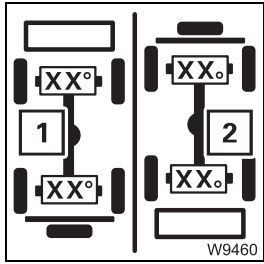

Steering display

- 1 Steering direction for 180° superstructure position on
- 2 Steering direction for 0° superstructure position on

▣▣▣▣ p. 14 - 12

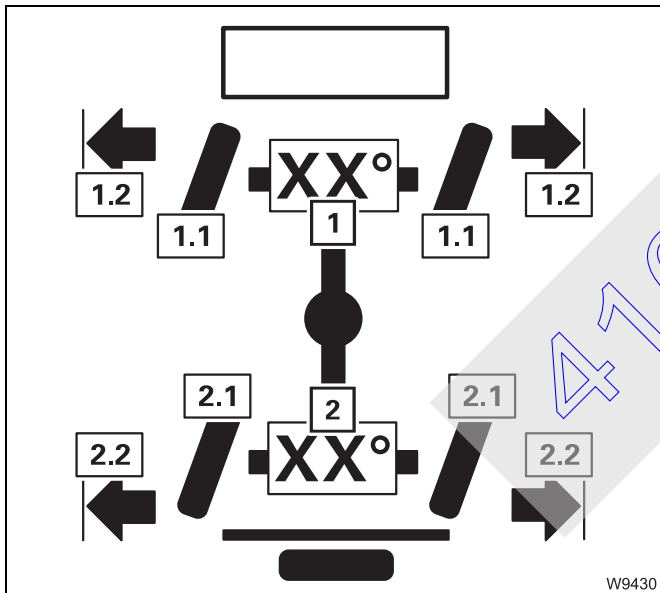

Current wheel position display

– **First and second axle line**

- 1 Steering angle in degrees
- 1.1 Steering angle in steps of 5° degrees
- 1.2 Steered to end position

– **Third and fourth axle line**

- 2 Steering angle in degrees – display only active with separate steering
- 2.1 Steering angle in steps of 5° degrees
- 2.2 Steered to end position

▣▣▣▣ p. 14 - 13

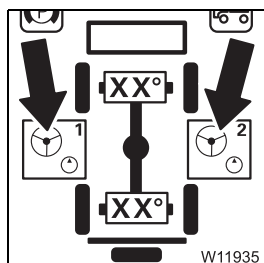

Warning for steering circuit 1 and steering circuit 2

The function is identical with the displays on the ECOS display in the driver's cab; ▣▣▣▣ p. 3 - 46.

Normal steering

Driver's cab: the ignition key is in position **1**.
Crane cab: the carrier ignition is switched on.

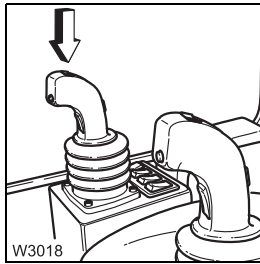

Steering in normal steering mode

The steering direction for the current superstructure position is switched on.

- Press button on left: left-hand turn
- Press button on right: right-hand turn

➡ p. 14 - 13

Separate steering

Driver's cab: the ignition key is in position **1**.
Crane cab: the carrier ignition is switched on.

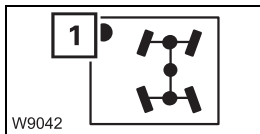

Separate steering on / off

- To switch on: press button once – dot (1) green
- To switch off: press button once – dot (1) black

➡ p. 14 - 14

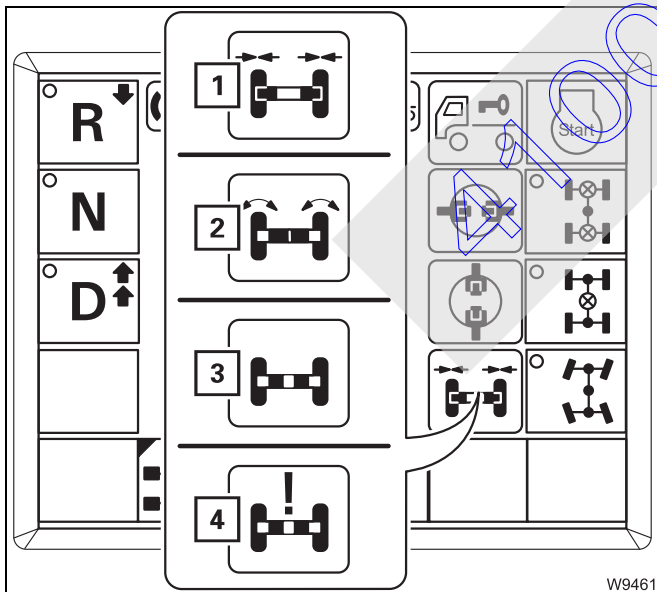

Steering locking status display

The current status is shown using different symbols:

- 1 Green – locked
- 2 Red – unlocked
- 3 Yellow – intermediate position
- 4 Violet – error

➡ p. 14 - 14

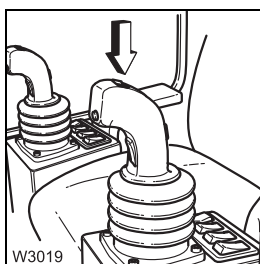

Steering with separate steering

The steering direction for the current superstructure position is switched on.

- Press button on left: left-hand turn
- Press button on right: right-hand turn

➡ p. 14 - 14

Blank page

41005067

11 Starting / turning off the engine – for crane operation

11.1	Starting the engine – from the crane cab	11 - 1
11.1.1	CHECKLIST: Starting the engine	11 - 1
11.1.2	CHECKLIST: If the temperature is low.	11 - 4
11.1.3	Refuelling.	11 - 5
11.1.4	Inspections before starting the engine	11 - 7
11.1.5	Switch on the ignition	11 - 8
11.1.6	Lamp test / equalisation of the switching states	11 - 9
11.1.7	Set brightness of display	11 - 11
11.1.8	To start the engine	11 - 12
11.1.9	Inspections after starting the engine.	11 - 14
11.1.10	Monitoring submenu	11 - 15
11.1.11	Setting the idling speed	11 - 16
11.2	Starting the engine – with the hand-held control	11 - 17
11.3	Turning off the engine.	11 - 19
11.3.1	During normal operation, with the ignition lock / with the hand-held control.	11 - 19
11.3.2	In emergencies, with the emergency-stop switches	11 - 20
11.4	Air intake inhibitor.	11 - 21

41005061

41005067

11

Starting / turning off the engine – for crane operation

11.1

Starting the engine – from the crane cab

This section describes only how to start the engine from the crane cab. You can also start the engine with the hand-held control;  p. 11 - 17.

11.1.1

CHECKLIST: Starting the engine



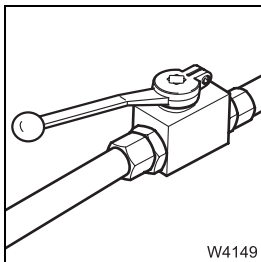

This checklist is not a complete set of operating instructions. There are accompanying operating instructions which are referred to by cross-references.

Observe the warnings and safety instructions specified there.

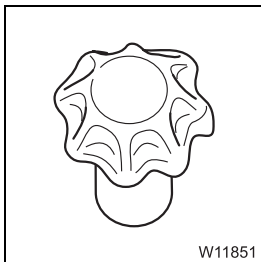

1. Check that the valve on the hydraulic tank is open;  p. 11 - 7.



2. Check the coolant level of the engine;  *Maintenance manual*.

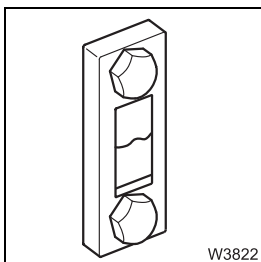

3. Check the oil level in the hydraulic system;  *Maintenance manual*.



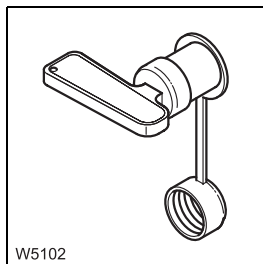

4. Switch on the battery master switch; p. 11 - 7.

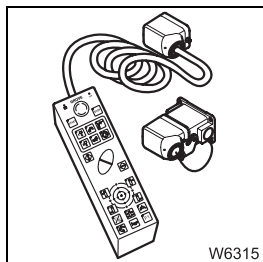

5. Remove the hand-held control and insert all bridging plugs;
 p. 11 - 8.

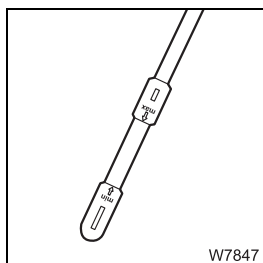

6. Check the oil level in the engine; *Maintenance manual*.

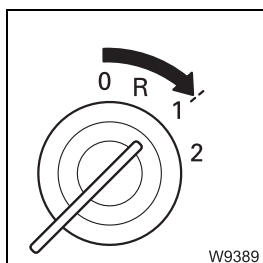

7. Switch on the ignition and check the instruments and displays;
 p. 11 - 8.

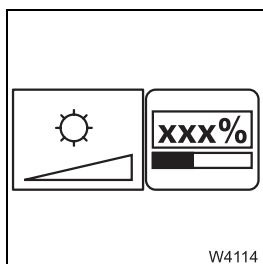

8. Adjust the brightness of the *ECOS* display as required; p. 11 - 11.

41005067

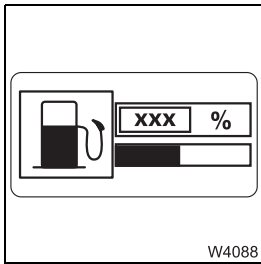

9. Check the fuel reserve; p. 11 - 5.

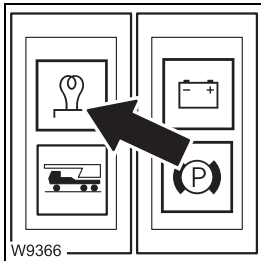

10. If the truck crane has a flame start system, wait until the lamp goes out;
 p. 11 - 13.

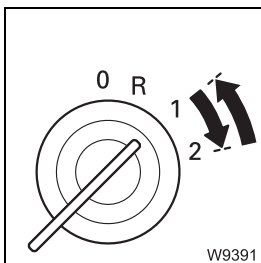

11. Start the engine; *To start the engine*, p. 11 - 12.

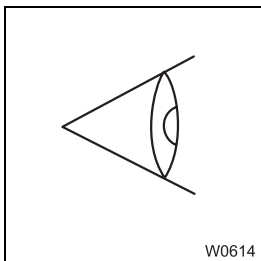

12. Check the instruments and displays with the engine running;
 p. 11 - 14.

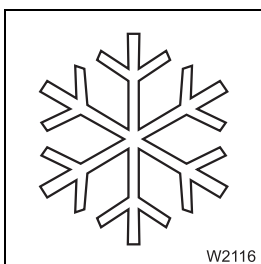

13. In the event of low outside temperatures; *CHECKLIST: If the temperature is low*, p. 11 - 4.

11.1.2

CHECKLIST: If the temperature is low

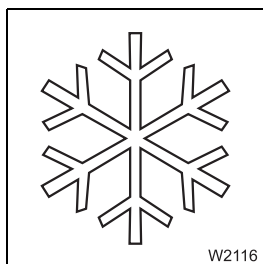

You must also observe the following points when operating the truck crane in low outside temperatures:

1. The fuel and engine oil must be suitable for use in the outside temperature in question; ■■■▶ *Separate engine operating instructions, provided by the manufacturer*
2. The engine coolant must contain sufficient antifreeze; ■■■▶ *Separate engine operating instructions, provided by the manufacturer.*
3. The windscreen washing system must contain sufficient antifreeze; ■■■▶ *Tank for windscreen washing system, p. 12 - 5.*
4. The engine can be preheated with the auxiliary water heater if necessary; ■■■▶ *Auxiliary water heater, p. 12 - 127.*
5. The hydraulic oil must be preheated; ■■■▶ *Preheating the hydraulic oil, p. 12 - 13.*

41005067

11.1.3 Refuelling

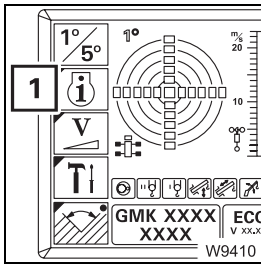

- If necessary, open the main menu **Esc** and press the button **(1)** once. The *Monitoring* submenu opens.

If a fuel tank is on the superstructure; *With additional equipment*, p. 11 - 6

For standard equipment

The engine for crane operation is supplied by the fuel tank on the carrier.

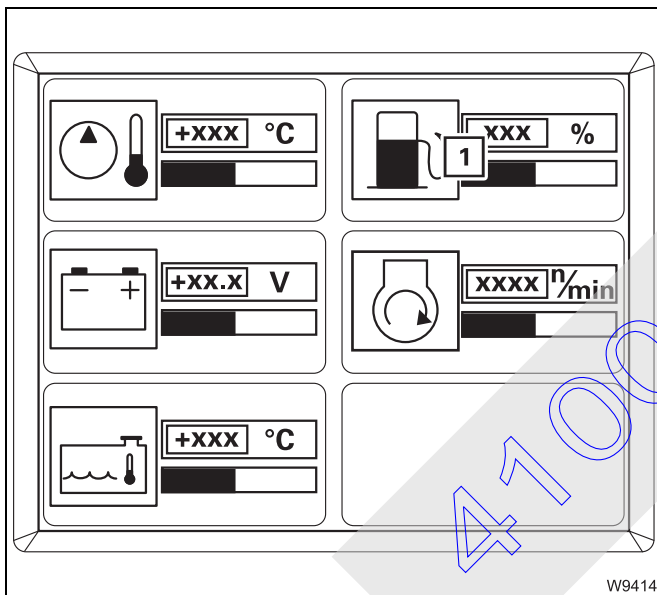

The display **(1)** indicates the current level as a percentage. 100% corresponds with approx. 400 l (106 gal).

The level indicator below the display changes its colour depending on the filling level:

- Green:** over 10% – over 40 l (10.6 gal)
- Yellow:** 5 to 10% – 20 to 40 l (5.3 to 10.6 gal)
- Red:** below 5% – less than 20 l (5.3 gal)

Refuelling, p. 4 - 7.



With additional equipment

The engine for crane operation is supplied by the fuel tank on the superstructure.

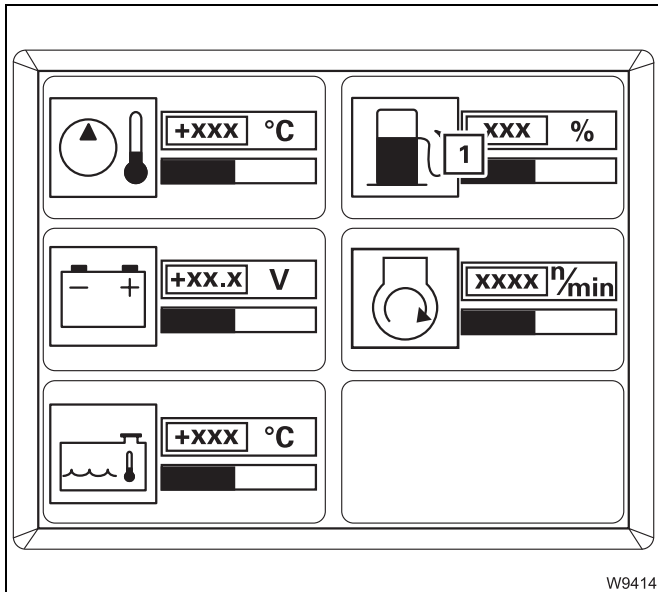

The display (1) indicates the current level as a percentage. 100% corresponds with approx. 230 l (61 gal).

The level indicator below the display changes its colour depending on the filling level:

Green: over 10% – over 23 l (6 gal)

Yellow: 5 to 10% – 11 to 23 l (3 to 6 gal)

Red: below 5% – less than 11 l (3 gal)



Danger of fire due to inflammable gases

Turn off the crane engine, crane cab heater and all auxiliary heaters before refuelling.

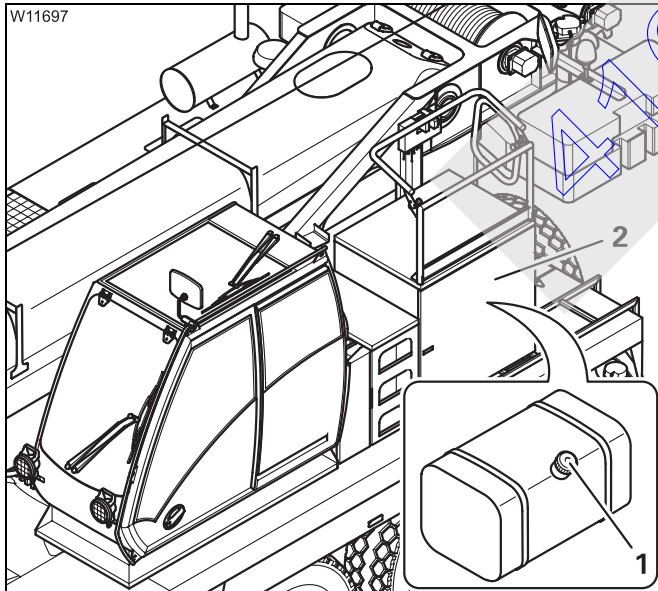

Information on the prescribed fuel specification  Separate engine operating instructions, provided by the manufacturer.

- Open the door (2).
- Fill in the diesel through the filler neck (1).
- Screw the cap onto the filler neck after refuelling.



Risk of accidents if the fuel tank is not closed

Screw the cap back onto the filler neck each time after refuelling.

In this way you can prevent other vehicles from being endangered by the cap falling off or fuel escaping.

11.1.4

Inspections before starting the engine

On the hydraulic tank

Before you start the engine, the valve on the hydraulic tank must be open.



Risk of damage to the hydraulic pumps

You may only start the engine when the valve on the hydraulic tank is open.

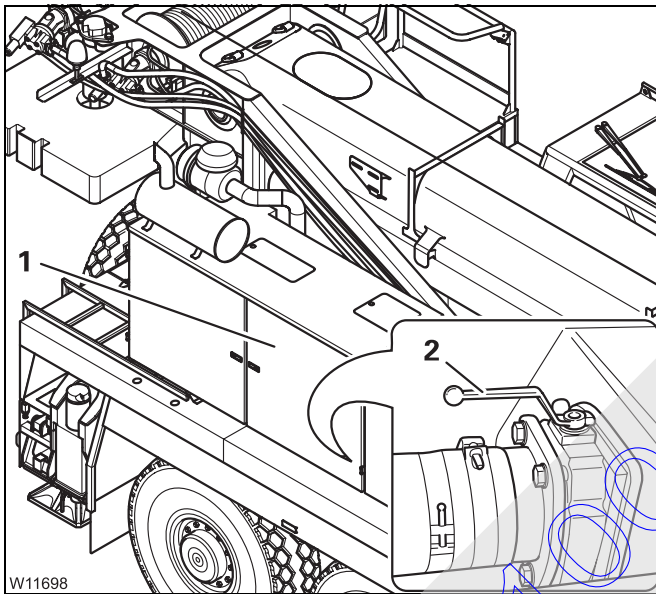

- Open the door (1).
- Check whether the valve is open – lever (2) parallel to the line.
- Open the closed valve.

Battery master switch

You can only start the engine when the battery master switch is switched on.

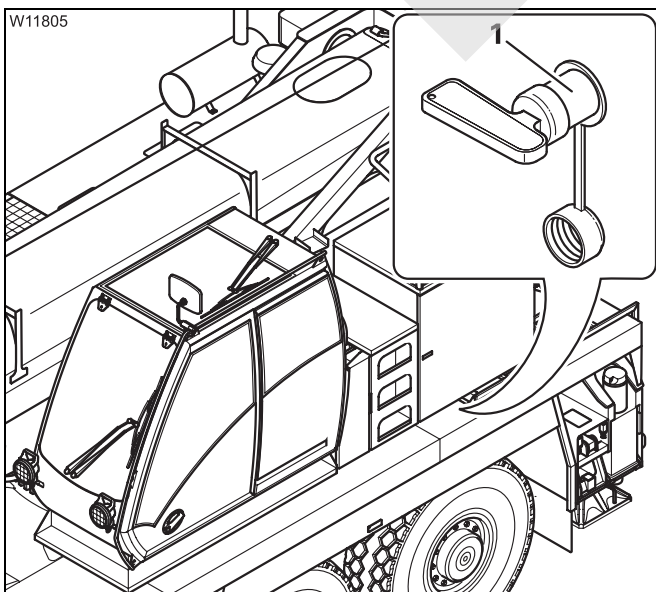

- Switch on the battery master switch (1).
- The battery master switch is switched on if you are unable to pull off the selector handle.



Checking the hand-held control

For crane operation from the crane cab the hand-held control must be removed.

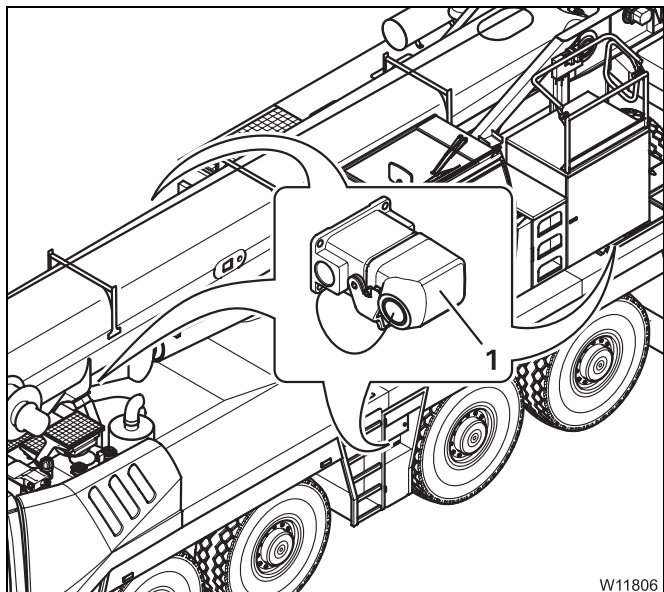

- Check whether the bridging plugs (1) are inserted in all the sockets; ■■■► p. 13 - 20.

If the hand-held control is connected, you can start the engine from the crane cab, but the operating elements for crane operation are disabled.

11.1.5

Switch on the ignition

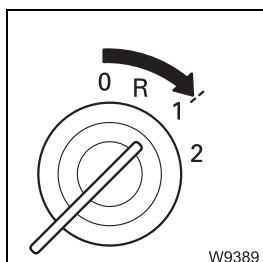

- Insert the ignition key into the ignition lock and turn the key to position 1. After switching on the ignition, a lamp test is carried out, and switching states are checked.

11.1.6

Lamp test / equalisation of the switching states

Lamp test

After the ignition has been switched on, a lamp test is conducted.

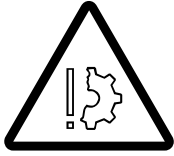

Risk of accidents due to faulty lamps

The lamps that are used to provide warnings and information during operation go on for control purposes whenever the ignition is switched on. Always perform the following lamp tests and immediately replace faulty lamps or have them replaced. In this way, you will avoid accidents and damage that occur when malfunctions are not identified in time.

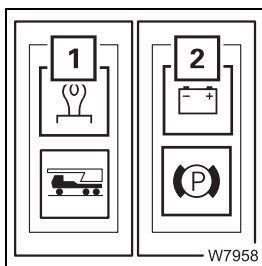

- Check whether the lamps (1) and (2) light up briefly

If the specified time is insufficient, switch on the ignition again.

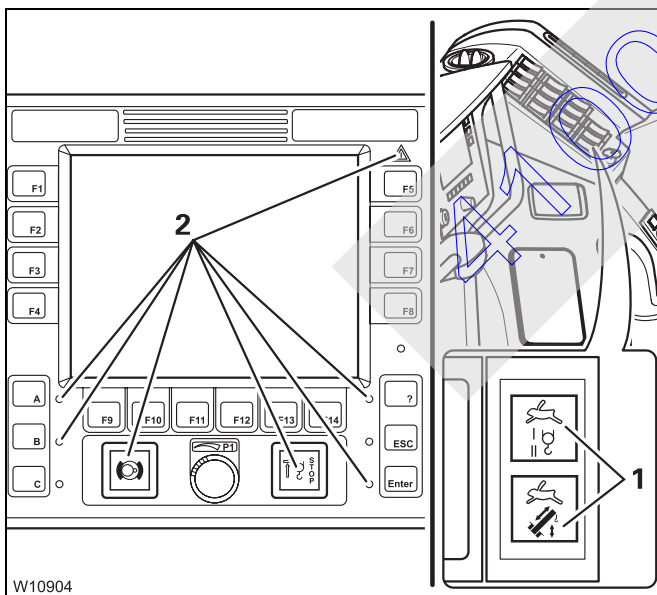

- Check whether the lamps (1) and (2) light up briefly

Contact **CraneCARE** if one or more lamps do not go on.

If the specified time is insufficient, you can carry out the lamp test again as follows.



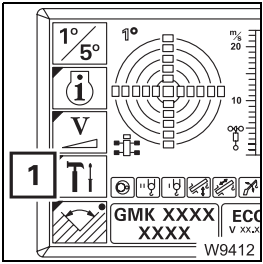

Conducting the lamp test

- If necessary, open the main menu  and press the button (1) once. The *Settings* submenu opens.

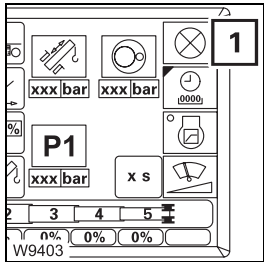

- Press the button (1). The above lamps go on until you let go of the button again.

If necessary, you can set the minimum brightness of the display;  p. 11 - 11.

Equalisation of the switching states

If the system features a *Driving* submenu, the switching states of the differential locks and the separate steering are equalised when the ignition is switched on.

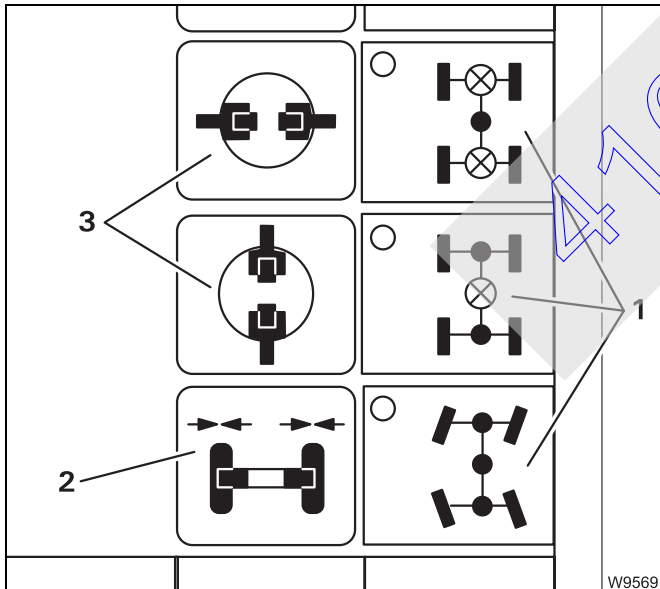

The state last saved is retrieved.

In the *Driving* submenu, the corresponding symbols (1) are shown and the electronics system triggers the switching operations.

The displays (2) and (3) show the current switching states on the carrier.

If the display (2) does not show the symbol that corresponds to the switching process, you must actuate the steering so that the locking processes are performed mechanically;  p. 14 - 15.

11.1.7 Set brightness of display

The brightness of the displays is automatically regulated by the ECOS displays, and depends on the brightness of the operating environment. You can set a minimum brightness display manually.

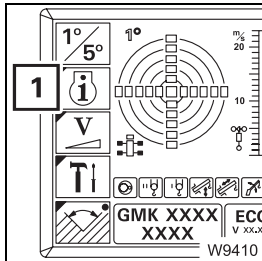

- If necessary, open the main menu  and press the button (1) once. The *Settings* submenu opens.

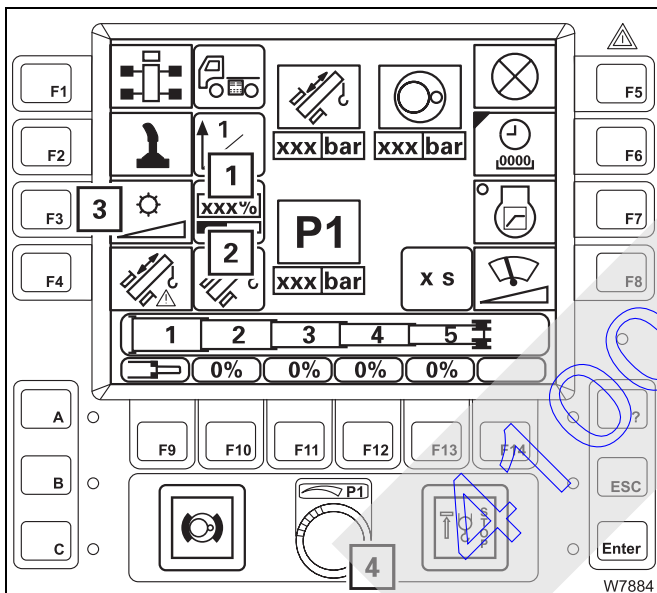

- Press button (3) once. A red bar (2) appears below the display (1).
- Set the required minimum degree of brightness with the switch (4). The brightness of the display changes during the setting procedure and you can view the set value (0 to 100%) on the display (1). The degree of brightness you set here is the minimum value for the automatic regulation.



There is no automatic regulation if you set 100%. The displays are always displayed with maximum brightness.

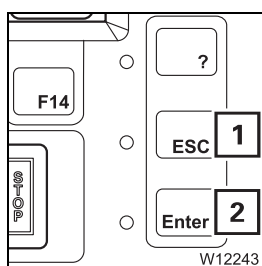

You can cancel the entry at any time using button (1). The settings are then reset.

- Apply the entered **minimum brightness** – 1 x button (2). The red bar below the display goes out. The brightness is automatically regulated between the newly set value and 100%.

11.1.8

To start the engine

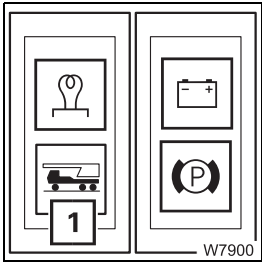

Refer to the separate operating instructions provided by the engine manufacturer for the operation of the engine. The engine can only be started if

- the bridging plugs have been inserted in all sockets of the carrier and superstructure for the hand-held control;  p. 13 - 20.
- the lamp (1) has gone out (carrier ignition off).



If the engine is equipped with a flame start system;  *With flame start system*, p. 11 - 13

Without flame start system



This section applies to starting a warm and a cold engine.

Danger of explosions when using starter fuel

The engine must never be started with the aid of starter fuel. The starter fuel sprayed into the suction unit may ignite.

- Do not press the accelerator
- Turn the ignition key to position 2 and hold it there until the engine goes on
- Let go of the ignition key after the engine goes on.

If the engine does not go on, abort the starting procedure after about 15 seconds and wait one minute before trying again.

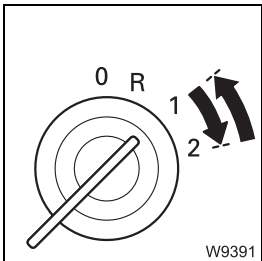

If the engine does not go on after several attempts;  *Malfunctions on the engine*, p. 15 - 13.

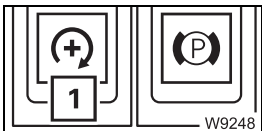

You can also start the engine by pressing button 1 down once with the ignition turned on. After starting, the idling speed corresponds to the standard value. To set the idling speed;  p. 11 - 16.

With flame start system

The flame start system warms the suction air of the engine.
This section applies to starting a warm and a cold engine.

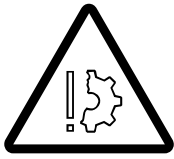

Danger of explosions when using starter fuel

The engine must never be started with the aid of starter fuel. The starter fuel sprayed into the suction unit may ignite.

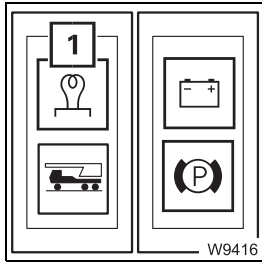

The flame start system is activated each time the ignition is turned on:

- **When the engine is warm**, the lamp (1) will light up only briefly (2 to 3 seconds).
- **When the engine is cold**, the lamp (1) goes out as soon as the engine has been preheated (duration of up to 20 seconds).
Start the engine within the next 30 seconds; otherwise, you must switch on the ignition again and wait until the lamp goes out.



If lamp (1) fails to go out, then there is a fault on the flame start system, please consult **CraneCARE**.

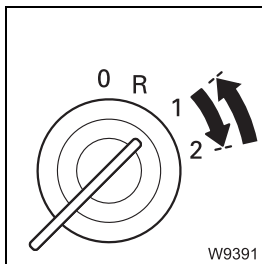

- Wait until the lamp (1) goes out
- Do not press the accelerator
- Turn the ignition key to position 2 and hold it there until the engine goes on
- Let go of the ignition key after the engine goes on
- If the engine does not go on, abort the starting procedure after about 15 seconds and wait one minute before trying again.



If the engine does not go on after several attempts;  *Malfunctions on the engine*, p. 15 - 13.

11.1.9

Inspections after starting the engine

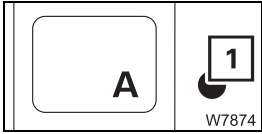



- Immediately after starting the engine, check the lamp (1) on the *ECOS* control unit.
The lamp (1) must go out approx. 10 seconds after starting the engine.



Risk of damage to the engine

If the lamp (1) does not go out after about 10 seconds, perform the following inspection and turn off the engine immediately if necessary.
The engine can be damaged by running it when the oil pressure is too low.



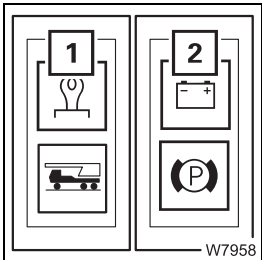

- Press the button  once The *Warning* submenu opens
- Turn off the engine immediately if the  symbol turns **red**
- Check the oil level;  *Maintenance manual*
- Correct the oil level if necessary. If the error message is still displayed, please contact **CraneCARE**.

If other symbols are displayed in red in this menu;  *Warning submenu*, p. 12 - 102.



- Also check the following lamps on the side panel
 - If the lamp (2) does not go out or lights up while the engine is running, switch the engine off and look for the cause.
 - If the lamp (1) does not go out or lights up while the engine is running, there is a malfunction in the flame start system.

 *Malfunctions on the engine*, p. 7 - 23

For more information please refer to the *Monitoring* submenu;  p. 11 - 15.

11.1.10 Monitoring submenu

The *Monitoring* submenu shows the most important measuring values.

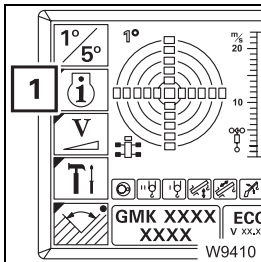

- If necessary, open the main menu  and press the button (1) once.

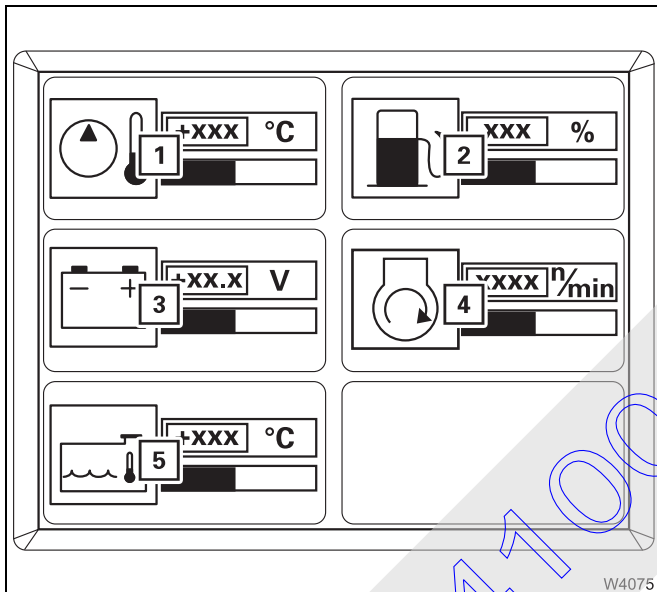

The *Monitoring* submenu opens.

The following values are displayed:

- 1 The hydraulic oil temperature in °C (°F)
- 2 The fuel supply as a percentage
 - in the carrier tank or
 - in the superstructure tank¹⁾
- 3 The voltage in Volts
- 4 The engine speed in min⁻¹ (rpm)
- 5 The coolant temperature in °C (°F)

¹⁾ Additional equipment

The colour of the bar below the values indicates in which area the value can be found.

Green: value o. k.

Yellow: limit value is almost reached

Red: limit value exceeded (or not reached) – warning message;
 p. 12 - 102.

11.1.11

Setting the idling speed

- Start the engine;  p. 11 - 12.

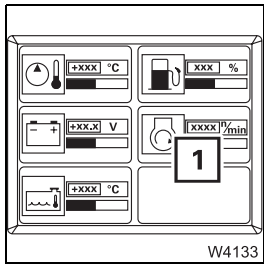

The display (1) in the *Monitoring* submenu  shows the current engine speed.

You can increase the idling speed for crane operation.

Release the accelerator in order to be able to view those settings which are below the current engine speed.

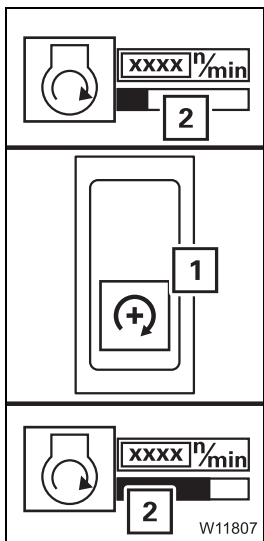

Increasing / decreasing the idling speed

- Press the button (1) down / up until the desired speed is reached. When reducing:
 - after approx. 3 seconds, idling speed = standard value.
 - after approx. 3 more seconds = engine off.It is only possible to restart the engine when approx. 7 seconds have elapsed.

or

- Press the button down / up once. The speed (2) is raised / reduced by one level.

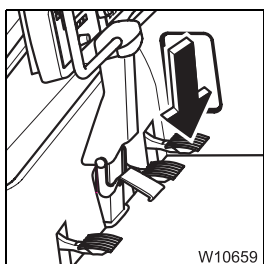

Exceeding the idling speed

You can exceed the idling speed at any time using the accelerator.

The engine speed is reduced to the preset idling speed if you release the accelerator.

11.2

Starting the engine – with the hand-held control

Prerequisites

You can only start the engine for crane operation if

- the bridging plug is inserted in all sockets not used; ■■■► p. 11 - 8 and
- the ignition in the driver's cab is switched off.

To start the engine

All inspections required before starting the engine must be done; ■■■► p. 11 - 1.

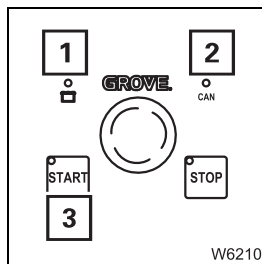

- Wait until the lamps (1) and (2) light up

There is a malfunction if the lamp (2) does not go on or flash after about 20 seconds; ■■■► p. 15 - 22.

Press the button (3) once – the engine starts.



If the hand-held control is connected to the superstructure, you cannot drive the power units from the crane cab.

Blank page

41005067

11.3 Turning off the engine

11.3.1 During normal operation, with the ignition lock / with the hand-held control



Risk of accidents due to suspended loads

Never turn off the engine with a load suspended. You must have the control levers at hand in order to intervene at any time.
Always set down the load before you leave the crane cab.

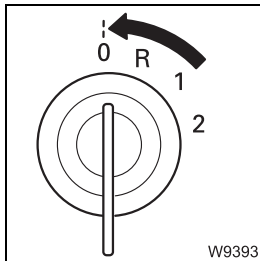

If the hand-held control unit is not connected up:

- Turn the ignition key to position 0 – the engine will stop

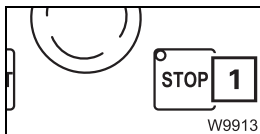

If the hand-held control unit is connected up:

- Press the button (1) once – the engine goes off

In this case it is not possible to switch off the engine with the ignition lock.

After parking

Observe the warnings in the appropriate sections;

- ▣▶ *Short work breaks*, p. 12 - 121,
- ▣▶ *Work breaks of more than 8 hours*, p. 12 - 122.

11.3.2

In emergencies, with the emergency-stop switches



Risk of overloading if used improperly

Use the emergency stop switches only in an emergency, i.e. if the crane functions no longer respond to the control levers.

Stopping crane movements suddenly may cause the truck crane to become overloaded under unfavourable conditions.

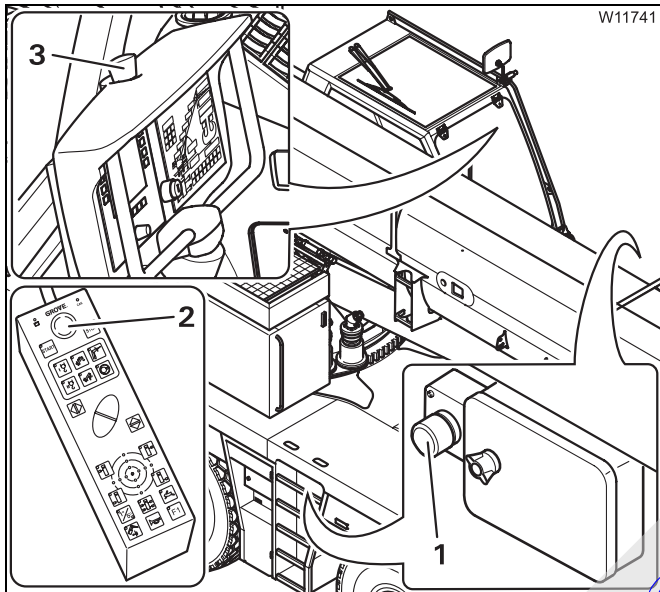

Four emergency stop switches are provided for an emergency:

- 1 On the carrier
- 2 On the hand-held control
- 3 In the crane cab

- Press one of the emergency switches (1), (2) or (3). The switch engages.

The engine goes out. If the engine for driving was on, it will go out as well.



If an air intake inhibitor is present, then it will be triggered – this also applies to the engine for driving.

Resetting the emergency stop switch

You can only restart the engine after you have reset the emergency stop switch.

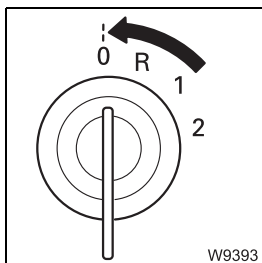

- Turn off the ignition

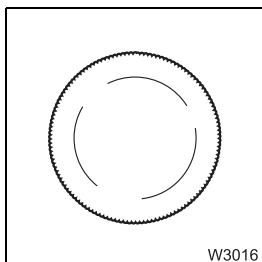

- Turn the actuated emergency-stop switch until it disengages again

If air intake inhibitors are fitted, they must be released;

▣▣▣▣▶ *Releasing the air intake inhibitor*, p. 11 - 21.

▣▣▣▣▶ *Releasing the air intake inhibitor*, p. 4 - 23.

11.4 Air intake inhibitor

If the air intake inhibitor is triggered, a flap in the air intake line will close and the engine will stop running. The air intake inhibitor is triggered

- If an emergency stop switch is actuated or
- when the maximum permissible engine speed is exceeded. In this case, the symbol (1) will turn **red** in the *Warning* menu. The symbol stays red until the ignition has been turned off.

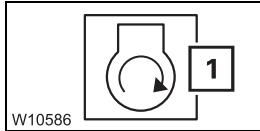

The engine can only be restarted after the air intake inhibitor has been released.

Releasing the air intake inhibitor

The following requirements must be met in order to release the air intake inhibitor:

- the ignition is switched off
- the emergency-stop switch is reset

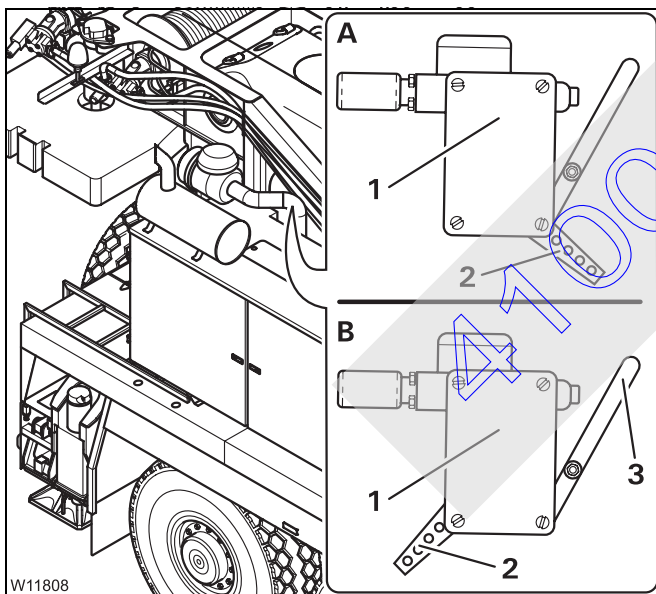

The indicator (2) shows the current state of the air intake inhibitor (1).

(A) – The indicator (2) is in the *closed* position.

(B) – Turn the indicator (2) clockwise until it engages into the *Released* position.

You can close the air intake inhibitor manually with the lever (3).

Blank page

41005067

12 Crane operation

12.1	Before crane operation	12 - 1
12.1.1	CHECKLIST: Inspections prior to crane operation	12 - 1
12.1.2	Checking the condition of the truck crane	12 - 5
12.1.3	Adjusting the crane cab seat and front panel	12 - 7
12.1.4	Checking the safety devices	12 - 9
12.1.5	Earthing the load	12 - 12
12.1.6	Preheating the hydraulic oil	12 - 13
12.1.7	Switching the houselock on / off	12 - 14
12.2	Operation of the safe load indicator	12 - 17
12.2.1	Switching on the SLI	12 - 18
12.2.2	Entering the rigging mode	12 - 21
12.2.3	Inspections prior to crane operation	12 - 29
12.2.4	Displays during crane operation	12 - 31
12.2.5	SLI early warning	12 - 35
12.2.6	SLI shutdown	12 - 36
12.2.7	Error message	12 - 37
12.2.8	SLI override	12 - 38
12.2.9	Displaying and entering the time and date	12 - 39
12.3	Crane operation with main boom	12 - 41
12.3.1	Checks during crane operation	12 - 41
12.3.2	Permissible slewing ranges and working positions	12 - 43
12.3.3	Main hoist	12 - 45
12.3.4	Auxiliary hoist	12 - 48
12.3.5	Lifting limit switch and lowering limit switch	12 - 51
12.3.6	Derricking gear	12 - 54
12.3.7	Telescoping mechanism	12 - 57
12.3.8	High speed	12 - 86
12.3.9	Slewing gear	12 - 88
12.3.10	Possible movement combinations	12 - 92
12.3.11	Hydraulic oil cooling	12 - 93
12.4	Settings and displays for crane operation	12 - 95
12.4.1	Inclining the crane cab	12 - 95
12.4.2	Setting the idling speed	12 - 95
12.4.3	Adjusting the stroke interval of the windscreen wiper	12 - 96
12.4.4	Limiting the power unit speeds	12 - 96
12.4.5	Setting the characteristic curve for the control levers	12 - 98
12.4.6	Critical load control	12 - 99
12.4.7	Operation of the directional spotlights	12 - 100
12.4.8	Displaying the operating hours	12 - 101
12.4.9	Warning submenu	12 - 102
12.4.10	Error submenu	12 - 106

12.5	Working range limiter	12 - 107
12.5.1	Opening the Working range limiter submenu	12 - 108
12.5.2	Viewing current settings.	12 - 108
12.5.3	Entering limit values.	12 - 110
12.5.4	Entering limit values / objects manually.	12 - 116
12.5.5	Switching monitoring functions on / off.	12 - 118
12.5.6	Shutdown by working range limiter	12 - 119
12.6	Work break	12 - 121
12.6.1	Short work breaks.	12 - 121
12.6.2	Work breaks of more than 8 hours	12 - 122
12.7	Heating and air-conditioning system	12 - 123
12.7.1	Standard heating system	12 - 123
12.7.2	Air-conditioning system	12 - 125
12.7.3	Auxiliary water heater	12 - 127
12.7.4	Auxiliary air heater	12 - 134

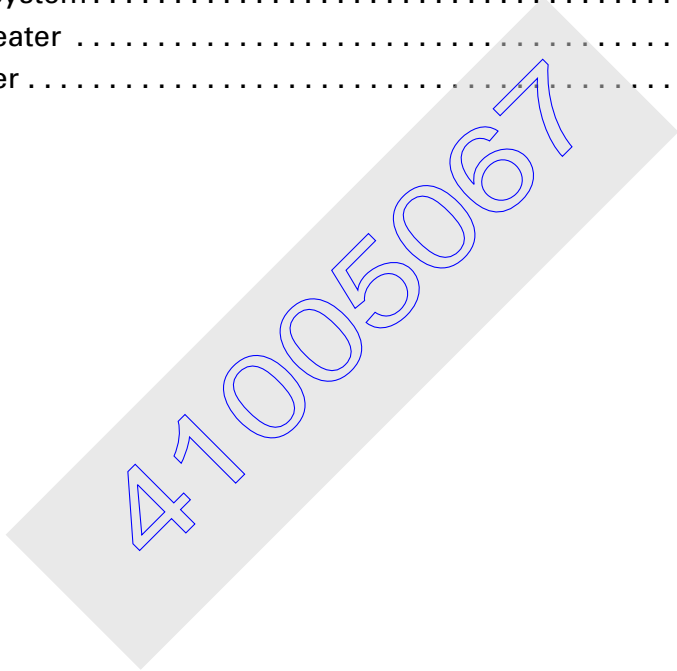

12

Crane operation

12.1

Before crane operation

12.1.1

CHECKLIST: Inspections prior to crane operation



This checklist is not a complete set of operating instructions. There are accompanying operating instructions which are referred to by cross-references.

Observe the warnings and safety instructions there.



This checklist only applies to working with a rigged truck crane (supported and rigged with counterweight). If the truck crane is not yet rigged;

▣▣▣▣ *CHECKLIST: Rigging*, p. 13 - 1.

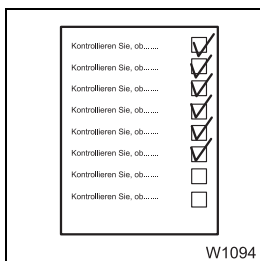

1. The truck crane has been rigged for the operation to be carried out as described in the *CHECKLIST: Rigging*; ▣▣▣▣ p. 13 - 1.

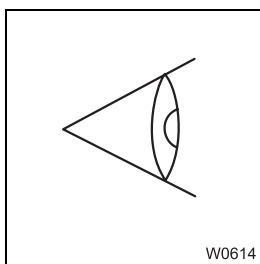

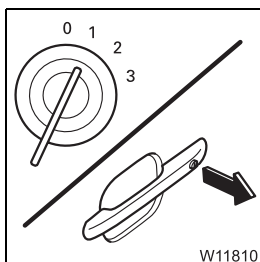

2. Carry out an inspection of the truck crane, looking out in particular for any leaking fluids (oil, fuel or water).



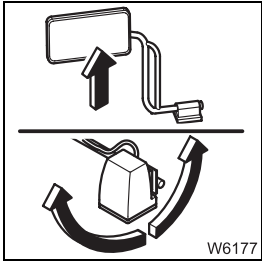

3. If you intend to drive from the crane cab:
 - in the driver's cab, turn the ignition key to position **1** and
 - secure the truck crane against unauthorised use.





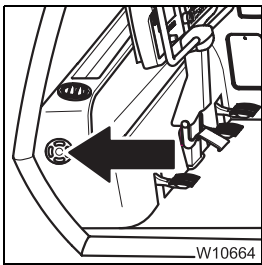

4. – Adjust mirrors for crane operation;  p. 13 - 114.
– Adjust the slewable spotlights if necessary;  p. 12 - 100.

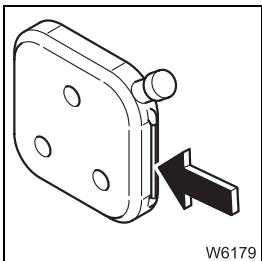

5. Windscreen washing system – check filling level;  p. 12 - 5.



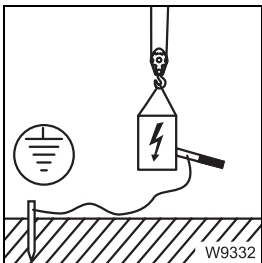

6. Auxiliary heater – check the fuel level;  p. 12 - 5.

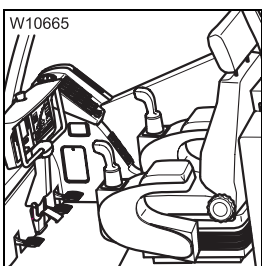

7. Earth the load, if necessary;  p. 12 - 12.



8. Adjust crane cab seat and front panel;
 *Crane cab seat*, p. 12 - 7,
 *Front panel*, p. 12 - 8.

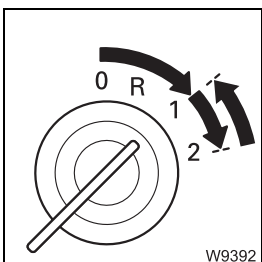

9. Start the engine for crane operation;  p. 11 - 12.

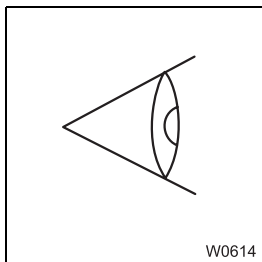

- 10. Check**
- SLI
 - Lifting limit switch
 - Seat contact switch and dead man's switch
 - Emergency stop switch
- for correct operation. Have faulty components repaired; p. 12 - 9.

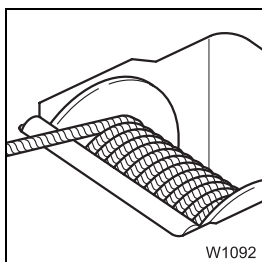

- 11. Check the position of the hoist ropes;** p. 12 - 6.

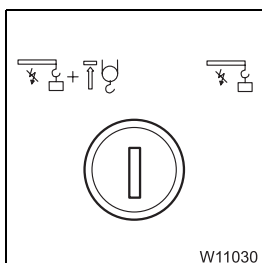

- 12. Remove key from the key-operated Override switch;** p. 12 - 38.

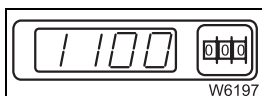

- 13. Compare current rigging mode to display on SLI – enter current rigging mode, if necessary;** p. 12 - 21.

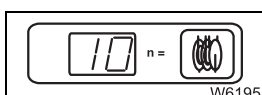

- 14. Compare current reeving of hoist used to the display on the SLI – enter current reeving, if necessary;** p. 12 - 25.

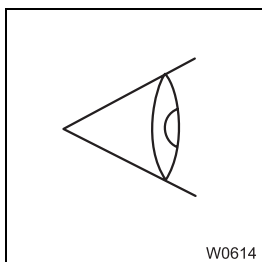

- 15. Check telescoping;** *Inspections prior to starting operations*, p. 12 - 64.



- 16. Perform lamp test on the SLI;** p. 12 - 20.



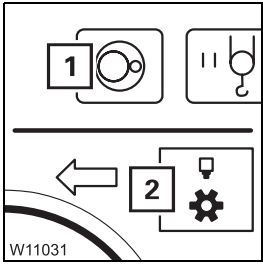

17. – Switch off the slewing gear for 0° and 180° working positions – symbol (1) red; ■■■▶ p. 12 - 92.

– Switch off houselock for other working positions – symbol (2) red; ■■■▶ p. 12 - 16.

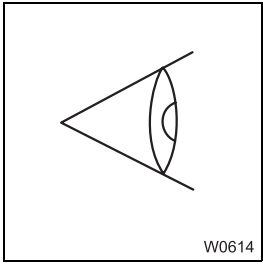

18. Check electrical system for correct operation; ■■■▶ p. 12 - 7.

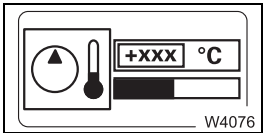

19. Check temperature of the hydraulic oil – preheat hydraulic oil, if necessary; ■■■▶ *Preheating the hydraulic oil*, p. 12 - 13.

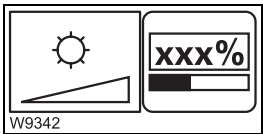

20. Adjust the brightness on the ECOS display as required; ■■■▶ p. 11 - 11.



Additional information on inspections during crane operation, on permissible working positions and on how to operate the individual power units; ■■■▶ *Crane operation with main boom*, p. 12 - 41.

12.1.2

Checking the condition of the truck crane

Tank for wind- screen washing system

Use a windscreen washing agent and, at low temperatures, an appropriate antifreeze.

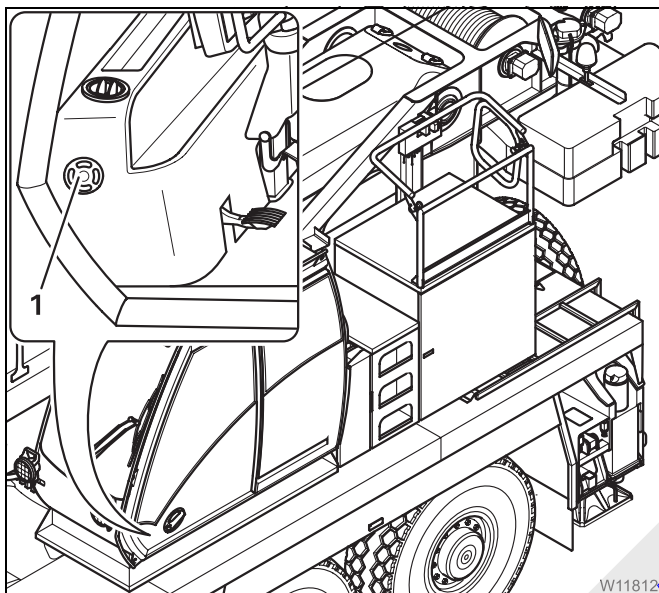

- Check the level in the tank (1).
- Top up water in due time, and close the tank (1) with the cap.

Auxiliary heater – tank

Only use the same fuel as for the engine or use EL heating oil for refuelling.



Danger of fire due to inflammable gases

Turn off the engine and heaters before refuelling.

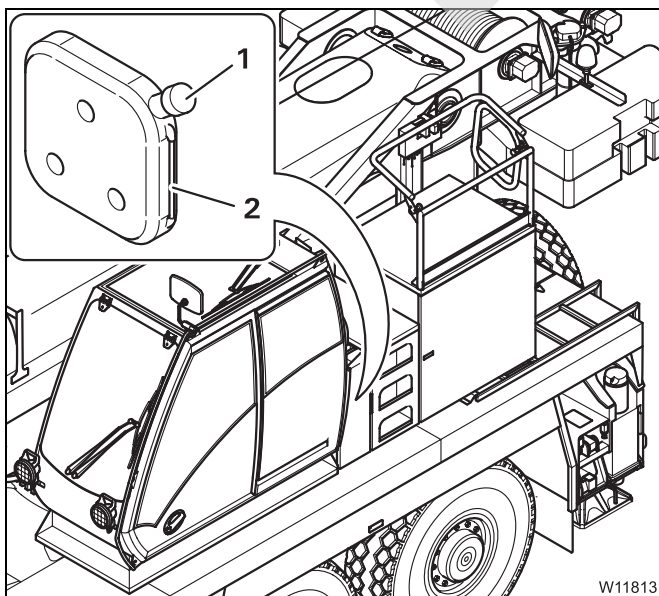

- The display (2) shows the fuel supply in the tank (1).
- Refill the fuel in due time, and close the tank (1) with the lid.
- If a fuel tank is available on the superstructure, then tank (1) is not applicable.



Visual inspection

Walk around the truck crane and look out in particular for leaking oil, fuel or coolant.



Danger if the crane cannot be unrigged

In the event of loss of oil, you may no longer be able to perform crane movements. Not even in emergency mode.



Risk of environmental damage due to leaking consumables

Immediately repair or have repaired oil, fuel and coolant leakages. That way you prevent oil or fuel from seeping into the ground or polluting waters.

Checking the position of the hoist ropes

The hoist mirrors need to be folded out; p. 113 - 114.



Risk of crushing due to turning rope drum

Keep away from the turning rope drum. This will prevent your limbs from being drawn in and getting crushed.

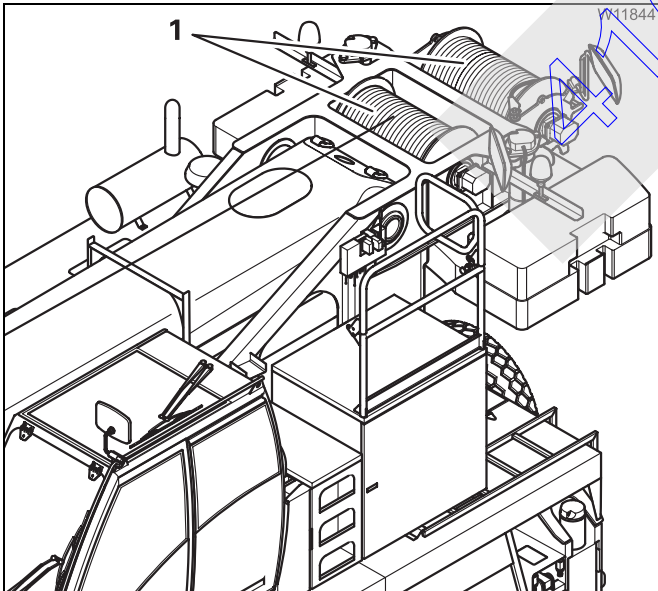

Check the position of the hoist ropes (1) on at least one full turn of the rope drum.

- Slowly carry out the movement *Lowering* and check the rope:
 - the hoist rope needs to be evenly wound.
 - the rope turns on the drum must be evenly spaced at a distance of 0 to 2 mm (0 to 0.08 in).
 - the cross-over points¹⁾ must be at an angle of about 180°.

¹⁾ The top rope lines are laid over the next lower rope lines at the cross-over points.

Checking the electrical system

- Check the following functions and have faulty parts repaired.



- Working area spotlights, air traffic control light, rotating beacons



- Windscreen wipers, windscreen washing system

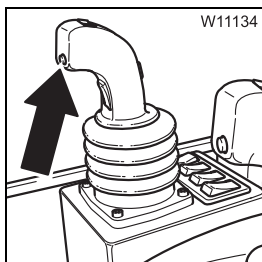

- Horn

12.1.3

Adjusting the crane cab seat and front panel

Crane cab seat

You can adjust the crane cab seat to your height.

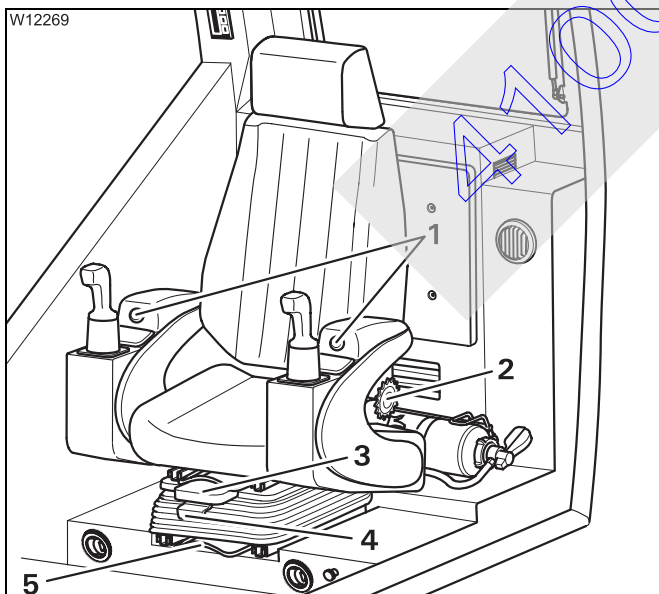

Version 1

- 1 Control panel – height
- 2 Back rest – angle (on both sides)
- 3 Seat – length adjustment without control panels
- 4 Seat – height
- 5 Seat – length adjustment with control panels



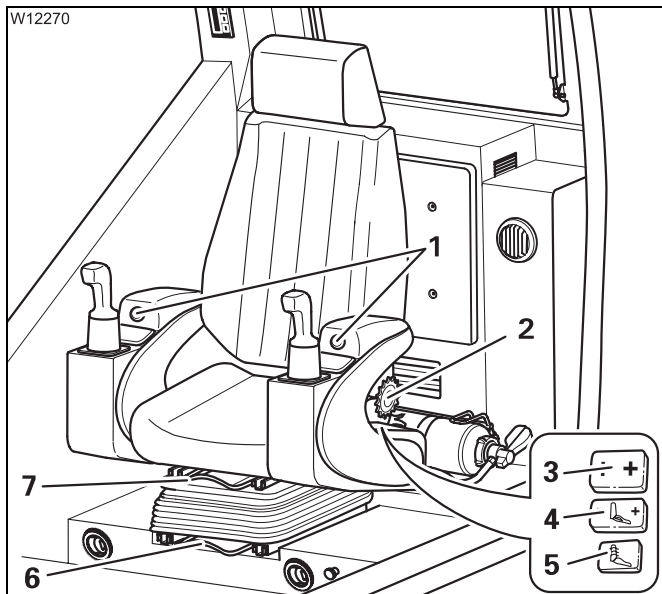

Version 2

- 1 Control panel – height
- 2 Back rest – angle
(on both sides)
- 3 Seat – length adjustment
without control panels
- 4 Seat – length adjustment
with control panels
- 5 Seat heating on / off
- 6 Lumbar area support¹⁾
- 7 Seat – height¹⁾

¹⁾ Requirement – ignition is on

For version 2 pay attention to the seat contact switch; ► p. 10 - 54.

Front panel

You can adjust the height of the front panel.

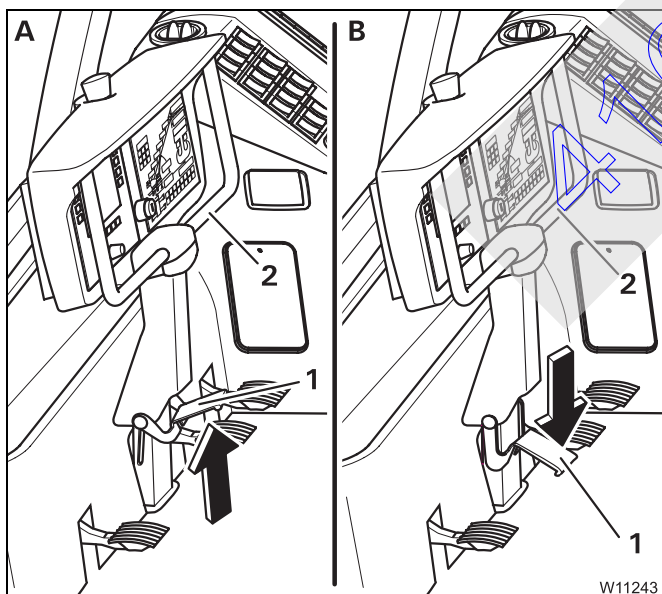

- (A) – Hold the front panel (1) by the handle (2).
- Fold the pedal (1) upwards.
- (B) – Adjust the front panel to the desired height.
- Fold down the pedal (1) to lock the front panel.

12.1.4

Checking the safety devices



Risk of accidents when working with faulty safety devices

It is prohibited to operate the crane with safety devices that are faulty, over-ridden or out of service.

Have faulty safety devices repaired immediately by **CraneCARE**.

Safe load indicator

- Switch on the safe load indicator, perform all inspections and enter the current rigging mode; *Switching on the SLI*, p. 12 - 18.

The SLI is working correctly at this point in time if no error message is pending and if the crane movements have been enabled.

If the SLI is not working correctly, do not begin to work with the crane but notify **CraneCARE**.

Lifting limit switch

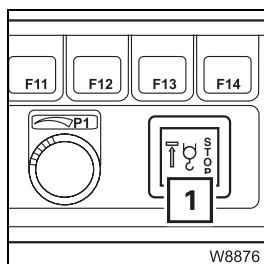

- Raise the main boom until the hook block is lifted off the ground.
- Slowly perform the *Raise* movement until the hook block lifts the lifting limit switch weight.
- Now check whether the movement *Raise* is switched off and the lamp (1) lights up.
- Check whether the movements *Lower* and *Extend* are also switched off.

The SLI is working correctly at this point in time if the lamp (1) lights up and the movements *Raise*, *Lower* and *Extend* are switched off.

If the lifting limit switch is not working correctly, do not begin to work with the crane but notify **CraneCARE**.



Emergency stop switch

- Set down the load and let go of both control levers.

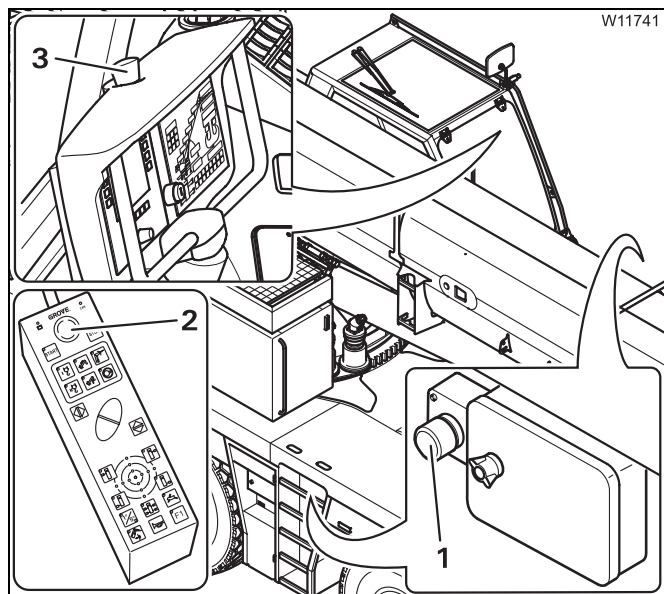

- Press the emergency stop switch (3) so that it engages.
- Check whether the engine stops.
- Turn the emergency stop switch until it disengages again.
- Release the air intake inhibitor if it is not already released;  *Air intake inhibitor*, p. 4 - 23.
- Perform the same inspection for the emergency switches (1) and (2).

If the emergency stop switches are not working correctly, do not begin to work with the crane but notify **CraneCARE**.

41005067

Seat contact switch



The check is made together with the dead man's switch.

Danger of accidents if the seat contact switch is faulty

Always stand inside the crane cab when you perform this inspection. If you stand next to the crane cab, you may be pushed off the carrier if the superstructure slews as a result of a faulty dead man's switch.

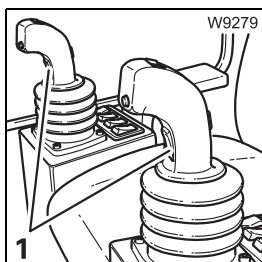

Checking with the truck crane at a standstill

- Do not sit down on the crane cab seat.
- Do not press any of the dead man's switches (1).
- Move the control levers one after the other for all the crane movements and check whether all the crane movements are switched off.

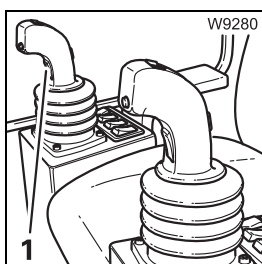

Checking during operation

– Dead man's switch

- Do not sit down on the crane cab seat.
- Press the right-hand dead man's switch (1) and slowly lift the hook block.
- With the control lever actuated, let go of the right-hand dead man's switch and check whether the crane movement comes to a standstill within approx. 3 seconds.
- Repeat the inspection with the dead man's switch on the left-hand control lever.

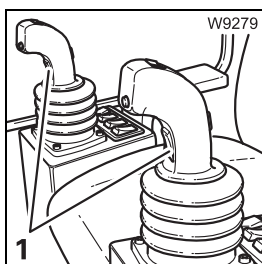

– Seat contact switch

- Do not press any of the dead man's switches (1).
- Sit down on the crane cab seat and slowly lift the hook block.
- With the control lever actuated, stand up and check whether the crane movement comes to a standstill within approx. 3 seconds.

If the dead man's switch system is not working correctly, do not begin to work with the crane but notify **CraneCARE**.

12.1.5 Earthing the load

Even if the truck crane is already earthed (p. 13 - 13), the load may become charged with static electricity. For example, if a hook block with synthetic sheaves or non-conducting sling gear is used.

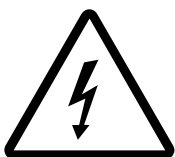

Risk of accidents due to electric shock

Always earth the load before operating the crane

- near strong transmitters (radio transmitters, radio stations, etc.)
- near high-frequency switching stations
- if a thunder storm is forecasted

If the load is charged with static electricity, you must always earth the load before touching it.

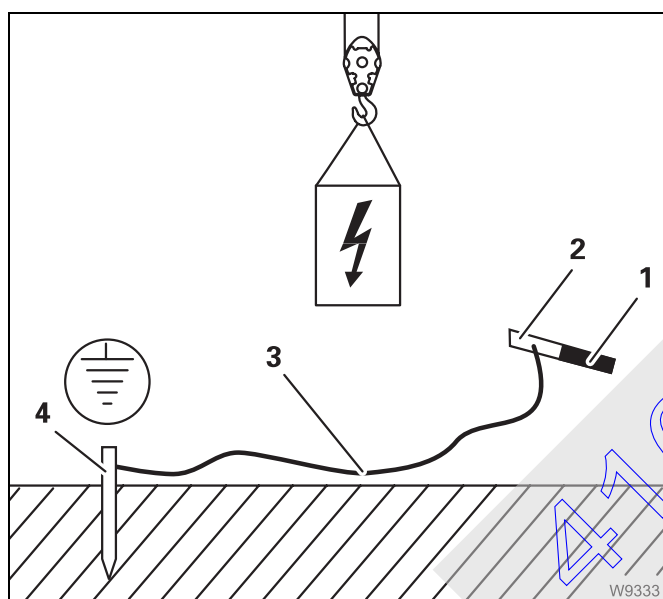

Use electrically conducting material for earthing.

- Hammer a metal rod (4) (length approx. 2.0 m (6.6 ft)) at least 1.5 m (5 ft) deep into the ground.
- Moisten the soil around the metal rod (4) for better conductivity.
- Clamp an insulated cable (3) to the metal rod (4) (cross-section of at least 16 mm² (0.025 in²)).
- Clamp the other end of the cable (3) to a metal rod (2) with an insulated grip (1).

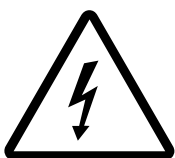

Risk of accidents due to electric shock

Ensure that the connections between the cable and the metal rods are electrically conductive. When earthing, hold the metal rod only by the insulated grip and keep a sufficient distance to the metal rod in the ground.

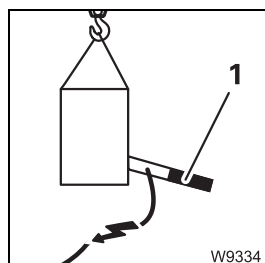

- Hold the metal rod by the insulated grip (1).
- To earth, touch the load with the metal rod.

12.1.6

Preheating the hydraulic oil



It may take a time for the solenoid valves to be activated or the power units may start abruptly if the oil is cold.

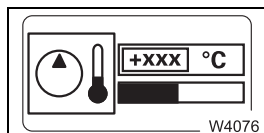

The current hydraulic oil temperature is displayed in the *Monitoring* sub-menu. To open the submenu; p. 11 - 15.

– Above 10 °C (50 °F)

Crane operation with load is permissible without speed restriction.

– From 0 °C to 10 °C (32 °F to 50 °F)

- To preheat, carry out crane movements with loads only in normal operation mode, at average engine speed and at average operating speed.

– From 0 °C to –15 °C (32°F to 5 °F)

- To preheat, only carry out crane movements **without a load**. Only operate at normal speed (crane movements), at medium engine speed and medium working speed.

– Below –15 °C (5 °F)

Crane movements are not permitted. Preheat the hydraulic oil first.

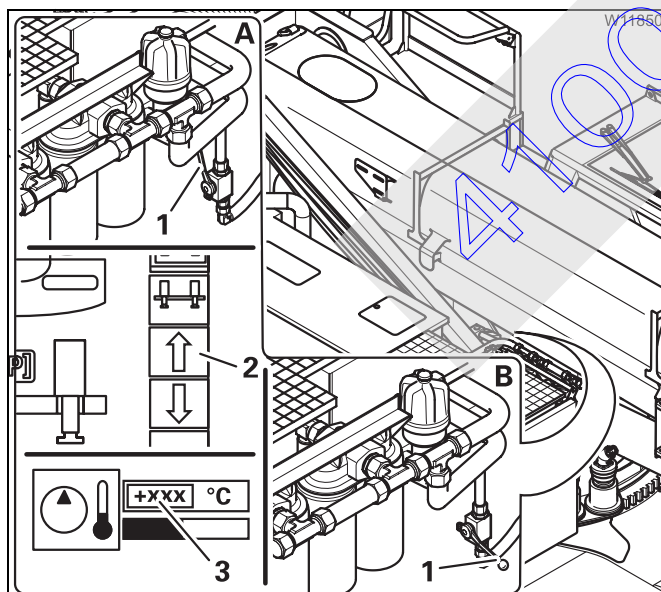

(A) – Preheating

- Open the valve – lever (1) parallel to the line.
- Press the button (2) and retract the lifting cylinders to the full extent; p. 13 - 73.

The hydraulic oil has been prewarmed when display (3) shows a temperature of at least 10 °C (50 °F).

(B) – Before crane operation

- Close the valve – lever (1) at right angles to the line.



Operate all crane functions at least twice after preheating (hydraulic oil temperature above 10 °C (50 °F)) in order to remove the cold oil from all parts of the hydraulic system.

12.1.7

Switching the houselock on / off

If the truck crane is equipped with a houselock, the turntable can be locked in the entire slewing range. For locking, a pin extends and blocks the slewing gear.

Switching on the houselock

- Slew the superstructure to the position in which it is to be locked and then stop the slewing movement.
- If necessary, open the main menu  and press the button **(1)** once. The *Superstructure lock* submenu opens.

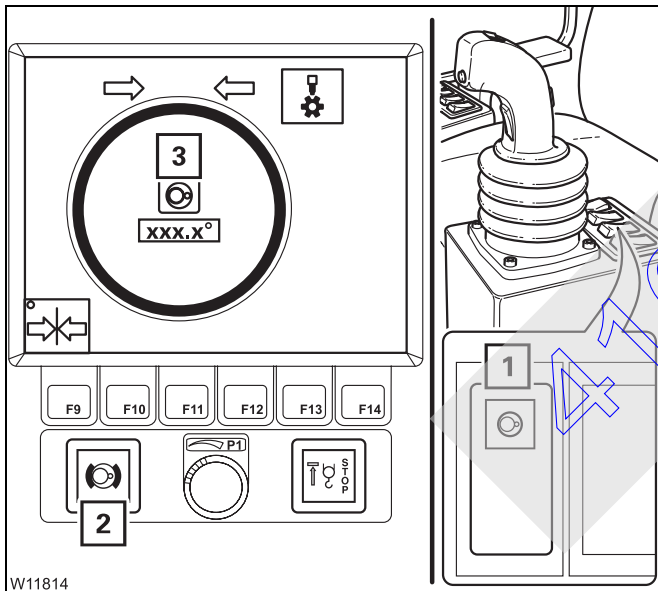
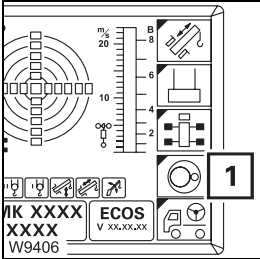

Switching off the slewing gear

The slewing gear brake must be engaged when operating the houselock.

- Press button **(1)** once. The slewing gear is switched off and the slewing gear brake is engaged.
 - The symbol **(3)** is red.
 - The lamp **(2)** lights up.



Risk of damage during slewing

Always switch off the slewing gear before you operate the houselock. The system will be damaged when slewing the superstructure during the locking procedure.

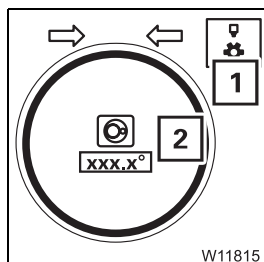

Switching on the houselock

The slewing ring (2) is displayed in the same colour as the displayed symbol (1) during the entire procedure.

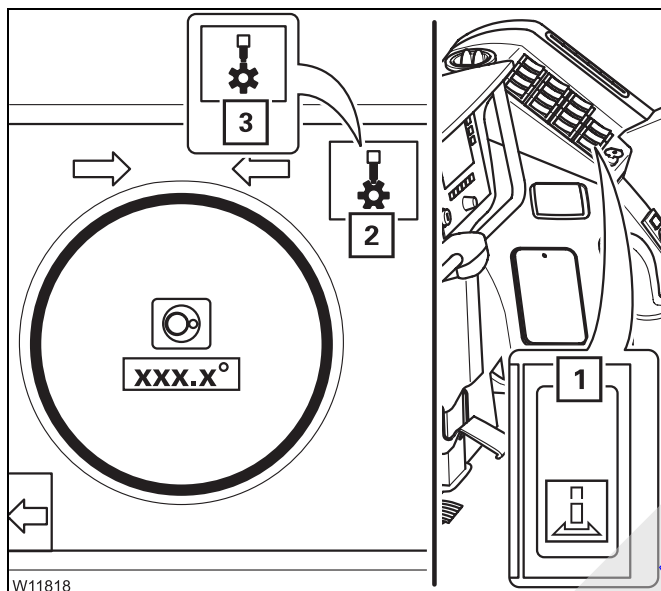

- Press the button (1) in at the top until the symbol (2) turns **green**.

The display first shows the symbol  in **yellow** and when the houselock is switched on, it shows the symbol (2) in **green**.

When the symbol (3) is **red / yellow**:

- Let go of the button (1).
The lock is blocked and you need to correct the position of the superstructure as follows:



Risk of damage due to slewing with blocked lock

Before slewing, make sure the symbol  is displayed in **red** (houselock off). Otherwise the system will be damaged during slewing.

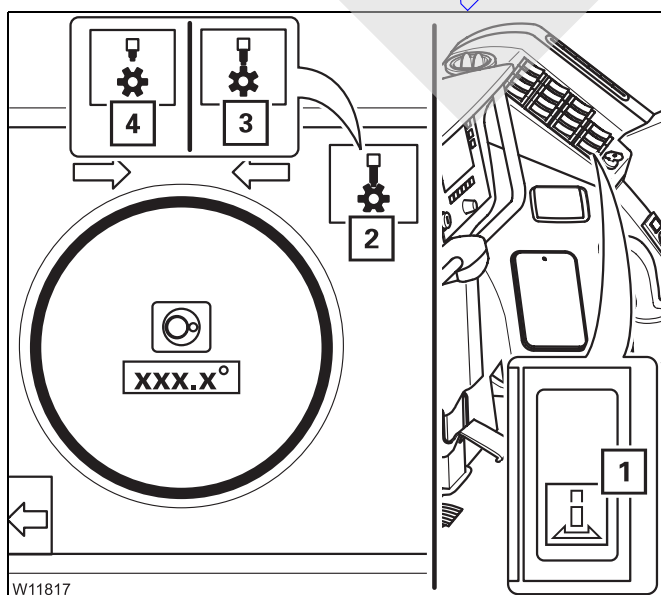

- Switch the houselock off – press the button (1) in at the bottom until the symbol (4) turns **red**.
- Apply the slewing gear brake.
- Switch on the slewing gear and slew the superstructure a little further (minimal).
- Switch off the slewing gear.
- Press the button (1) in at the top until the symbol (2) turns **green**.
- If the symbol (3) is still displayed, you must correct the position of the superstructure once more.



Switching off the houselock

- Check that the slewing gear is switched off, and switch it off if it is not;
 ▶ *Switching off the slewing gear*, p. 12 - 14.



Risk of damage during slewing

Always switch off the slewing gear before you operate the houselock. The system will be damaged when slewing the superstructure during the locking procedure.

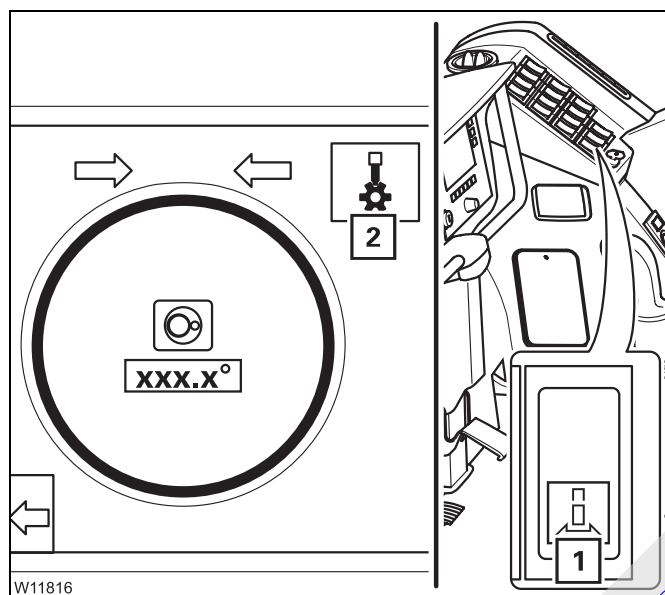

- Press the button (1) in at the bottom until the symbol (2) turns **red**.

The display first shows the symbol  in **yellow** and when the houselock is switched on, it shows the symbol (2) in **red**.

41005067

12.2

Operation of the safe load indicator

The safe load indicator is abbreviated in these operating instructions as **SLI** (**Safe-Load-Indicator**).

If the current rigging mode of the truck crane is registered properly, the SLI prevents the permissible lifting capacity from being exceeded and the truck crane from being overloaded.



Risk of accidents due to incorrectly set SLI

Before operating the crane, ensure that the current rigging mode is correctly entered. An incorrect input will give you a false sense of security. This results in the truck crane overloading and causing an accident.

The current rigging mode is registered partly based on measured values and partly based on values entered manually.

Based on measured values	Based on values entered manually
– Main boom length	– Outrigger span
– Main boom angle	– Counterweight
– Current load	– Lattice extension length
– Lattice extension inclination	– Reeving

During the operation of the crane, a visual and acoustic early warning is issued before the load limit is reached and then the functions are shut down that would lead into the overload range.



Risk of accidents due to overridden or faulty SLI

The SLI must never be overridden.

It is prohibited to work with the SLI if it is switched off, overridden, out of service or faulty.



Danger of overturning in two-hook operation mode

The safe load indicator only secures one-hook operations! Two-hook operations are not permitted.

12.2.1

Switching on the SLI



The SLI is not switched off if you turn the ignition key to position **R** instead of position **0** to restart the engine. The test program will not run and you will not have to acknowledge the settings again.

Switching on

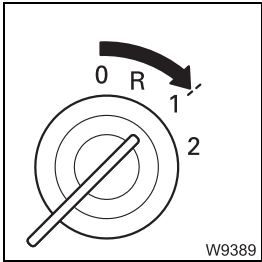

The SLI is switched on together with the ignition.

- Turn on the ignition.

A test program runs after switching on the ignition. A continuous buzzer tone sounds for about 5 seconds and a lamp test is performed.

- Check whether you can hear a buzzer tone.



Risk of accidents if the safety devices are faulty

If the lamps or the buzzer fail, notify **CraneCARE** and have the error rectified. In the meantime, pay particular attention to the lamps in the event of a failure of the buzzer tone and vice versa.

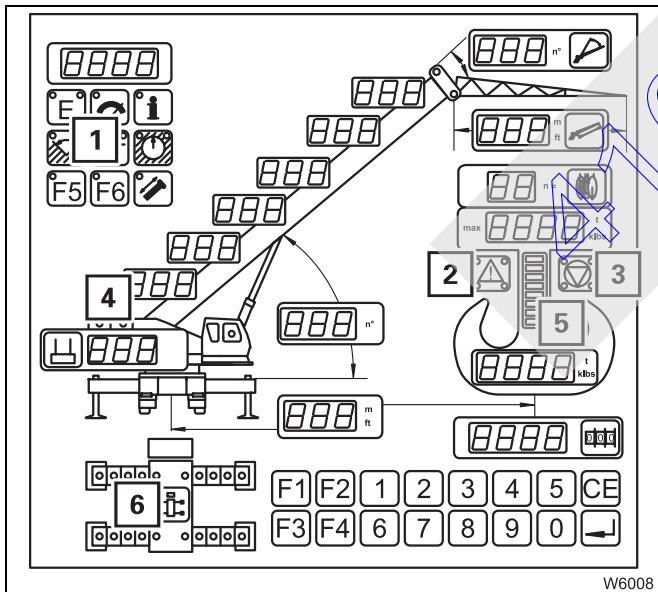

- Check whether the following lamps go on after turning on the ignition:

- in the buttons (1),
- on the displays (4), (5) and (6)
- and the lamps (2) and (3).

- Check whether all digits flash on all displays
- Notify **CraneCARE** and have the error eliminated in the event of faulty safety devices



If you are unable to check all lamps in the specified time, you can repeat the lamp test on the *SLI* control unit; p. 12 - 20.

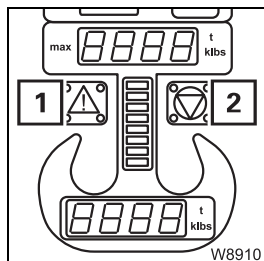

After the test program:

- the lamps (1) and (2) are on
- all power units are disabled

The current display depends on whether the SLI:

- had been switched off for less than 48 hours or
- had been switched off for longer than 48 hours

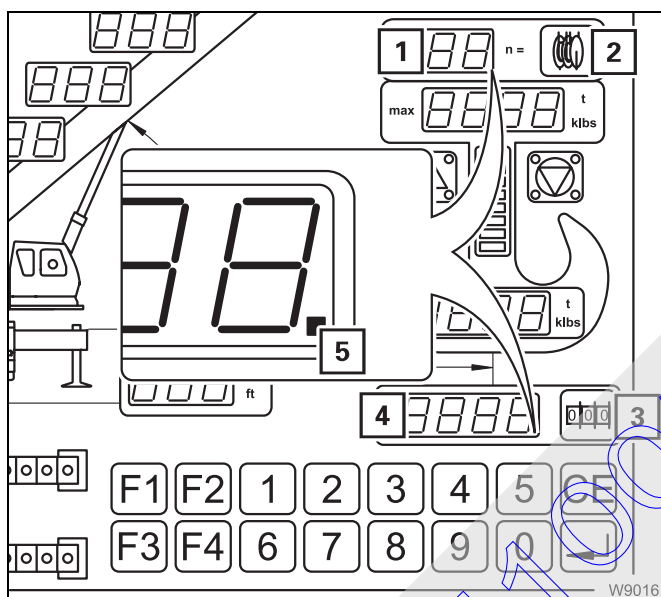

After a standstill of less than 48 hours

The displays (1) and (4) correspond to the rigging mode set last. The display (1) shows the signalling point (5).

You can save the displayed values if they correspond to the current rigging mode:

- Press button (2) once.
The signalling point switches to the display (4).
- Press button (3) once.
The signalling point goes out.

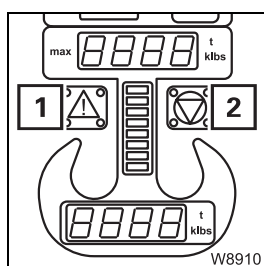

The lamps (1) and (2) go out. The SLI code is accepted.

If no error message is displayed, the SLI is now set for crane operation and the crane movements are enabled; *Inspections prior to crane operation*, p. 12 - 29.

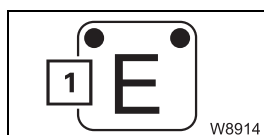

If there is an error message, both lamps in the button (1) go on; *Error message*, p. 12 - 37.

You must re-enter the current rigging mode if the displayed values do not correspond to the current rigging mode of the truck crane; *Entering the rigging mode*, p. 12 - 21.



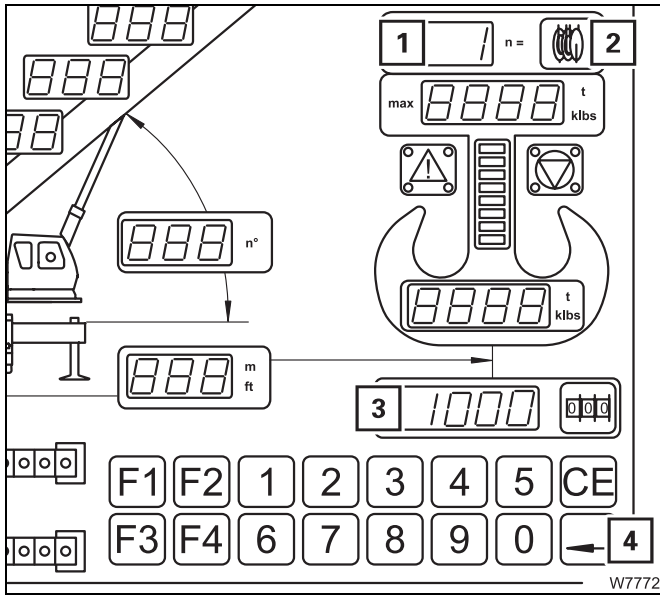

After a standstill of more than 48 hours

Displays (1) and (3) show the entries 1 and 1000.

Display (1) is switched to input mode and the entry 1 flashes.

- Enter the current reeving;
 - ▮▮▮▮ Entering individual components, p. 12 - 26,
 - ▮▮▮▮ Confirming the SLI code, p. 12 - 23,
 - ▮▮▮▮ Accepting the SLI code, p. 12 - 24.

After accepting the value, display (3) switches to input mode and the entry 1000 flashes.

- Enter the SLI code for the current rigging mode; ▮▮▮▮ Entering the rigging mode, p. 12 - 21.

Lamp test on the SLI

You can perform a lamp test on the SLI control unit at any time.

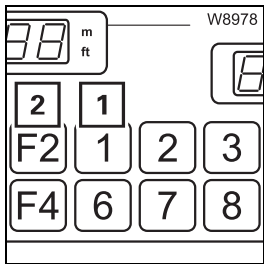

- Keep the button (2) pressed and additionally press the button (1) once. All displays and lamps must light up to maximum brightness. After about two seconds the current display appears with the brightness automatically set.

Brightness of the displays

The brightness of all displays and lamps is adjusted automatically to the ambient brightness after turning on the ignition.

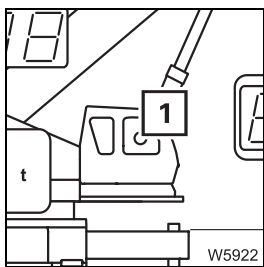

Do not cover the sensor (1) and keep it clean to avoid soiling affecting the adjustment of the brightness.

12.2.2 Entering the rigging mode

For a complete rigging mode input, you must enter, confirm and accept the rigging mode and the reeving separately.



Risk of accidents if the rigging mode is incompletely set

The crane movements are enabled as soon as you accept the SLI code or reeving. Therefore, always check whether both values correspond to the current rigging mode before operating the crane. In this way you prevent the SLI from incorrectly calculating the permissible load and the truck crane from being overloaded or overturning.

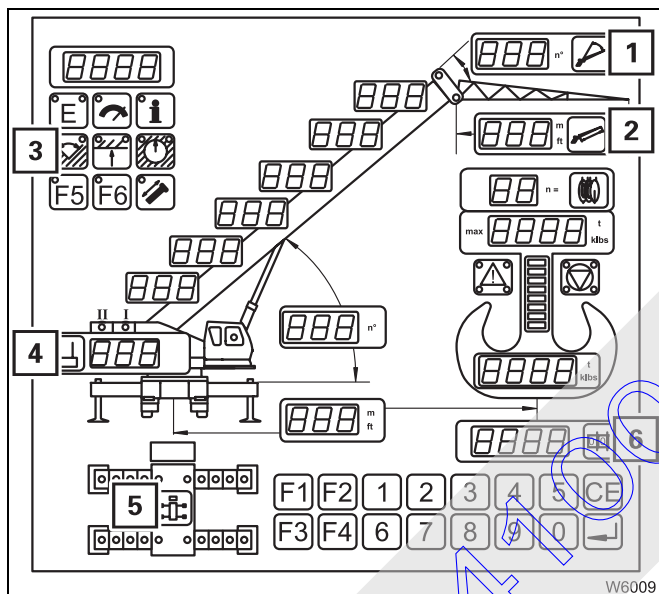

There are two ways of entering the rigging mode.

– You can enter the SLI code for the current rigging mode on the display (6).

or

– You can select the individual components (1) to (5) for the current rigging mode one after the other.

With both ways, you must confirm and accept the current rigging mode on the display (6).

The complete input procedure for the SLI code is described in the following section. To enter the rigging mode based on individual components;
▣▣▣▣ *Entering individual components*, p. 12 - 26.



Entering the SLI code

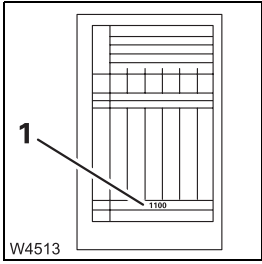

You must enter the SLI code for the rigging mode according to the *Lifting capacity table*.

- Refer to the *Lifting capacity table* for the current rigging mode. The corresponding SLI code (1) is specified at the bottom of the table (e.g. 1100).

Entries are made in four steps:

- switch on input mode
- enter the SLI code
- confirm SLI code and
- accept SLI code.

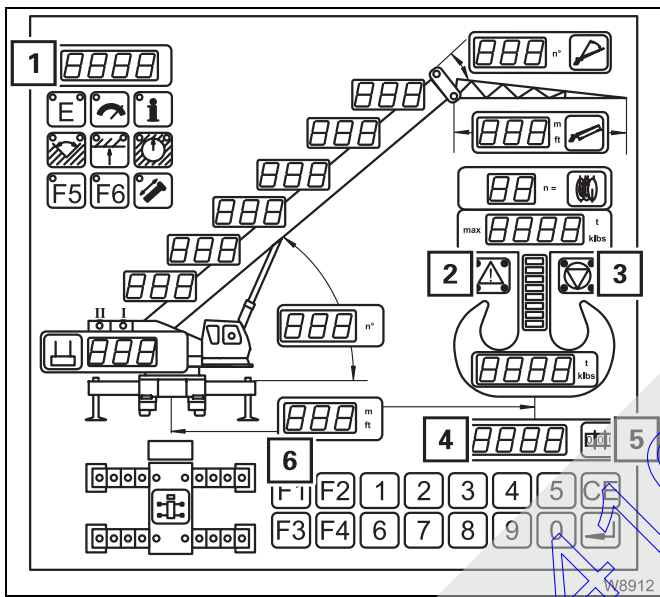

To switch on input mode

- Press the button (6) and additionally the button (5) once.

The value on the display (4) flashes.

Lamps (2) and (3) light up.

The display (4) is now switched to input mode and you can enter a new SLI code.

The display (1) automatically switches to the permissible slewing range.

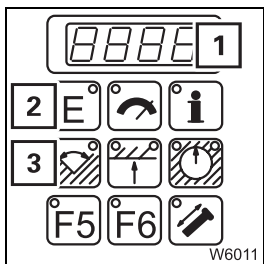

In input mode, the display (1) does not automatically switch to error codes. If an error occurs, the lamps in the button (2) flash.

To display error codes, you must press the button (2).

You can switch back to the display of the permissible slewing range by pressing the button (3).

Entering the SLI code

You can only confirm SLI codes for slewing ranges other than 360°

- if the slewing gear is switched off in the 0° / 180° working position.
- if the superstructure is in the entered slewing range. If necessary, first enter an SLI code for the 360° slewing range and slew the superstructure into the required position.

You can enter the SLI code as individual digits or select a permissible value.

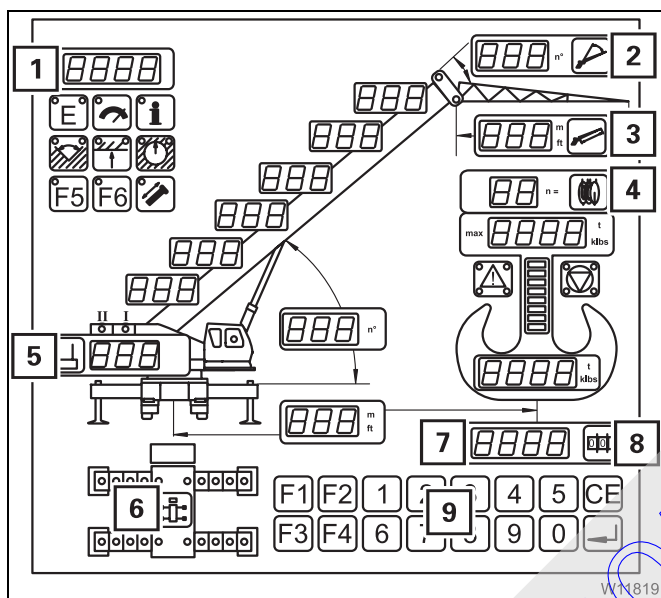

Entering as digits

- Enter the digits of the required SLI code one after the other with the buttons (9).

The entered value flashes on the display (7) and the corresponding rigging mode is displayed on the displays (1) to (6).

Selecting an SLI code

- Press the button (8) repeatedly until the required SLI code flashes on the display (7).

The values are displayed repeatedly in ascending order.

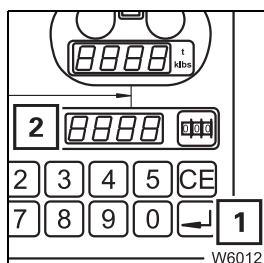

Confirming the SLI code

- Press button (1) once.
 - If the SLI code is permissible, the display (2) does not flash any more and the signalling point is displayed. The entry has been confirmed.



- If the SLI code is not permissible, the lamps in the button (1) flash. Press the button (1) once to display the error codes; see p. 15 - 28.



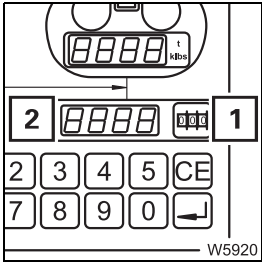

Accepting the SLI code

You can only accept the SLI code if the signalling point is displayed (2).

- Press button (1) once.

The signalling point goes out and the SLI code is accepted.



Risk of accidents if the rigging mode is incompletely set

The crane movements are enabled as soon as the SLI code is accepted. Make certain, however, that the current reeving value is entered before beginning to operate the crane.

In this way you prevent the SLI from incorrectly calculating the permissible load and the truck crane from being overloaded or overturning.

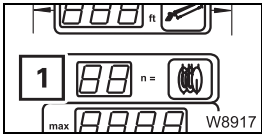

- Check whether the display (1) indicates the current reeving.

You must enter the current reeving value if a different reeving value is displayed; see p. 12 - 25.

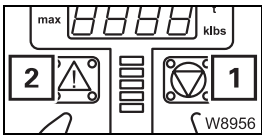

If there are no more error messages and all error messages which have occurred have been acknowledged, the lamps (1) and (2) go out. The crane movements are now enabled; see *Inspections prior to crane operation*, p. 12 - 29.

41005067

Entering the reeving

The rigging mode is only completely entered once you have entered the current reeving value after the SLI code has been accepted.

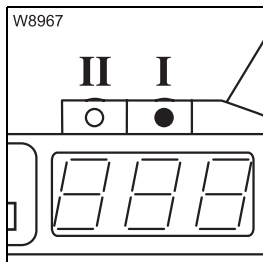

The newly entered reeving value always applies to the hoist of which lamp (I or II) is on, for example lamp I for the main hoist.

- Check whether the load is to be lifted with the displayed hoist and, if necessary, switch the display to the other hoist; *Example of how to switch over the display, p. 12 - 30.*

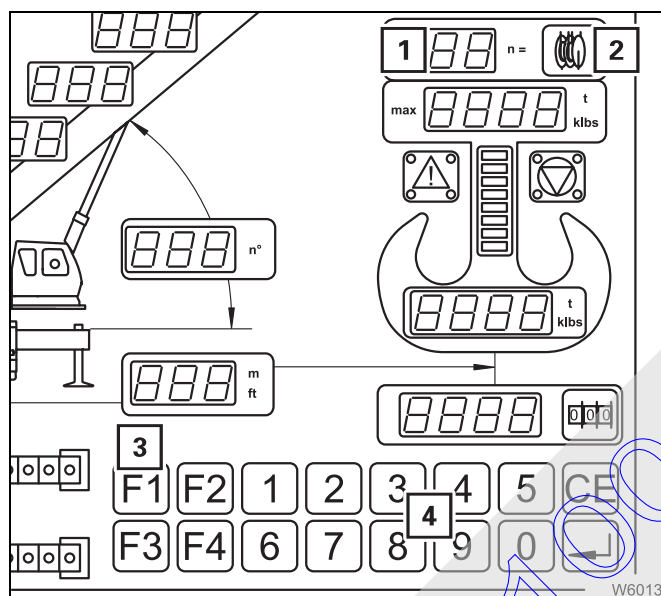

To switch on input mode

- Press the button (3) and additionally the button (2) once.

The value on the display (1) flashes.

Entering the reeving

- Enter the number of currently reeved rope lines with the buttons (4).
- or
- Select the value with the button (2).



If the entry $n =$ next to the display (1) flashes, the number of entered rope lines is too low to lift the maximum possible load according to the *Lifting capacity table*; p. 12 - 32.

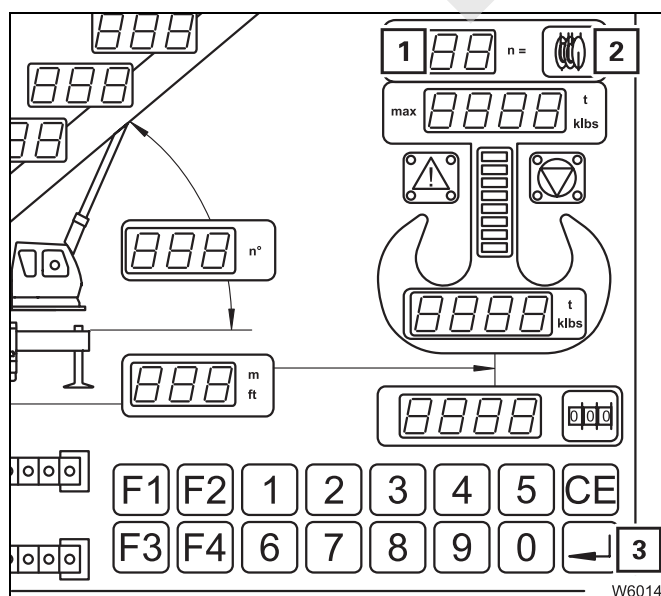

Confirming the reeving

- Press button (3) once.

The entry is confirmed and the signalling point displayed (1).

Accepting the reeving value

- Press button (2) once.

The signalling point disappears and the reeving value is accepted.



Entering individual components

You can also enter the current rigging mode by selecting the individual components on the displays.



Danger of overturning due to incorrectly set rigging mode

Values which have already been set may change when entering individual components. For this reason, you should always compare the displayed rigging mode with the current rigging mode of the truck crane after making the entry. In this way you can prevent the SLI from calculating with incorrectly set components and the truck crane from becoming overloaded or overturning.

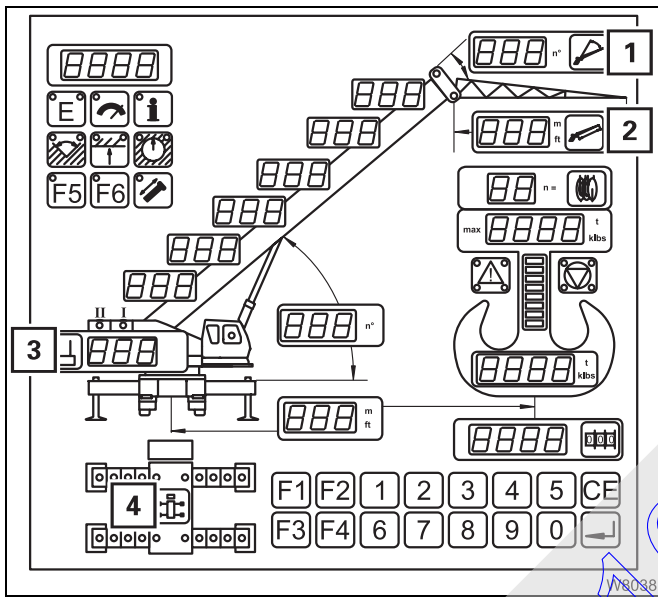

When completely re-entering the rigging mode, you can prevent components already entered from changing by making entries in the following order:

- counterweight (3)
- lattice extension length (2)
- angle of the lattice extension (1) – inclinable
- outrigger span (4).

In this order, the values that can be selected for the current entry are always restricted by the previous entry. As a result, values that have already been entered do not change.

The respective SLI code is calculated from the entered components and displayed directly on the *SLI code* display.

Entries are made in four steps:

- switch on input mode
- select values
- confirm SLI code and
- accept SLI code.

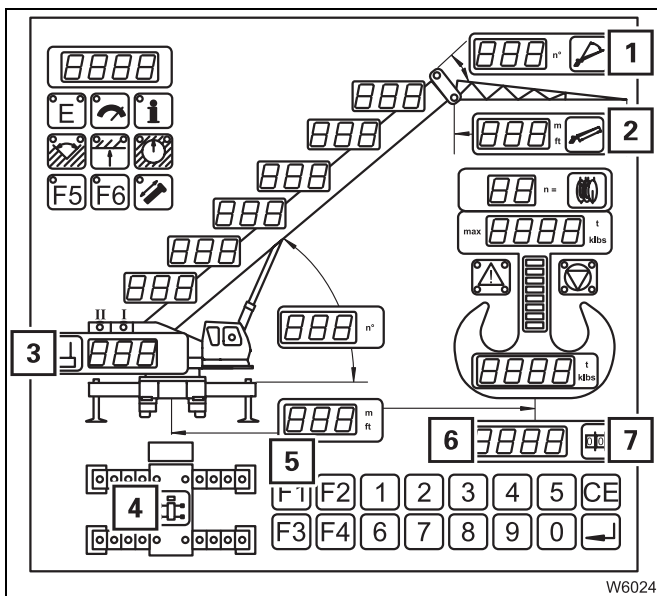

To switch on input mode

- Press the button (5) and additionally the button (7) once.

The value on the display (6) flashes.

Input mode is switched on and the displays for the components (3) and (4) are activated.

The displays (1) and (2) are only activated if an SLI code for a lattice extension is shown.

Selecting values

You can now select the values permitted for the individual components according to the *Lifting capacity table*. These values cannot be entered on the numerical keypad.

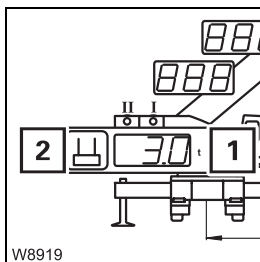

The selection procedure is the same for all components and it is described based on the example of the counterweight.

The display (1) shows the counterweight for the set SLI code, e.g. **3.0 t**.

- Press button (2) once.

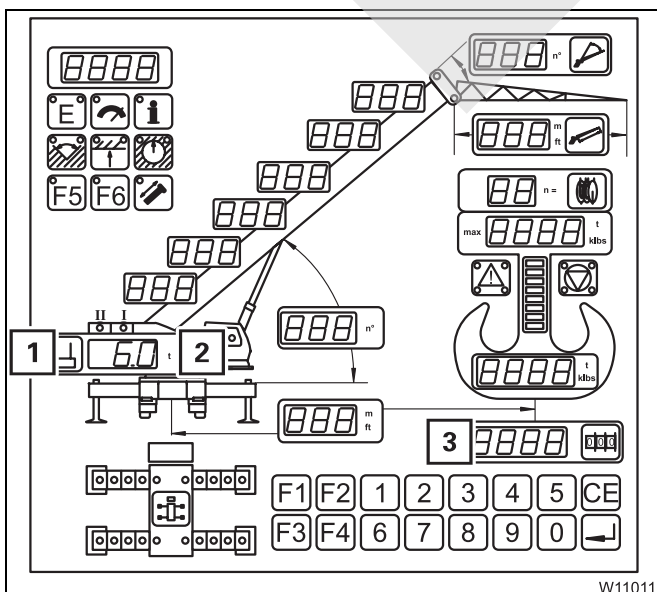

The display (2) shows the next higher value, e.g. **6.0 t**.

- Press the button (1) repeatedly until the currently rigged counterweight version flashes on the display (2).

The values are displayed repeatedly in ascending order.

The display (3) shows the corresponding SLI code for each newly selected value.



Enter the current rigging mode at the other components in the same way.

- Lattice extension

An SLI code for the lattice extension must be displayed,  *Entering the SLI code*, p. 12 - 22.

- Press the button (1) repeatedly until the currently rigged lattice extension length flashes on the display (2).

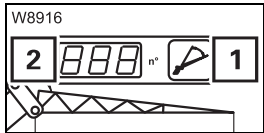
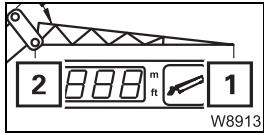

Lattice extension – inclinable:

Keep pressing the button (1) until the currently set lattice extension angle flashes in the display (2).

- Outrigger span

Press the button (1) repeatedly until the lamps for the current outrigger span go on, e.g. for the outrigger span of 8.55 x 8.10 m (28.1 x 26.6 ft).

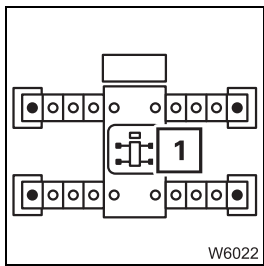

You must confirm the displayed SLI code after selecting the current rigging mode.

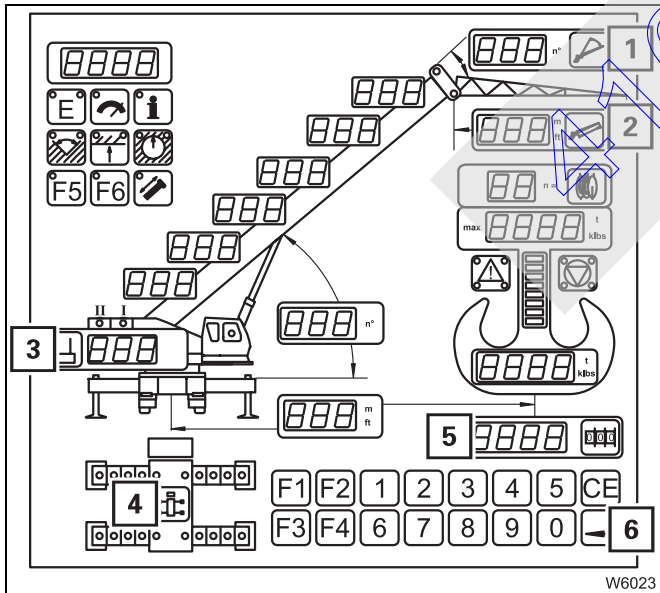

Confirming the SLI code

The display (5) now shows the SLI code for the newly entered rigging mode.

To confirm the newly entered components (1) to (4), you must confirm this SLI code.

- Press button (6) once.

The SLI code on the display (5) does not flash any more and the signalling point is displayed.

The entry is confirmed and you can accept the SLI code.

Accepting the SLI code

 *Accepting the SLI code*, p. 12 - 24.

12.2.3

Inspections prior to crane operation



Risk of accidents due to incorrectly set SLI

If the current rigging mode varies from the displayed rigging mode, the maximum load displayed by the SLI does not correspond to the actually permissible lifting capacity according to the *Lifting capacity table*. Overloading and accidents will be the result.

- Check whether the current rigging mode of the truck crane corresponds to the displayed rigging mode.

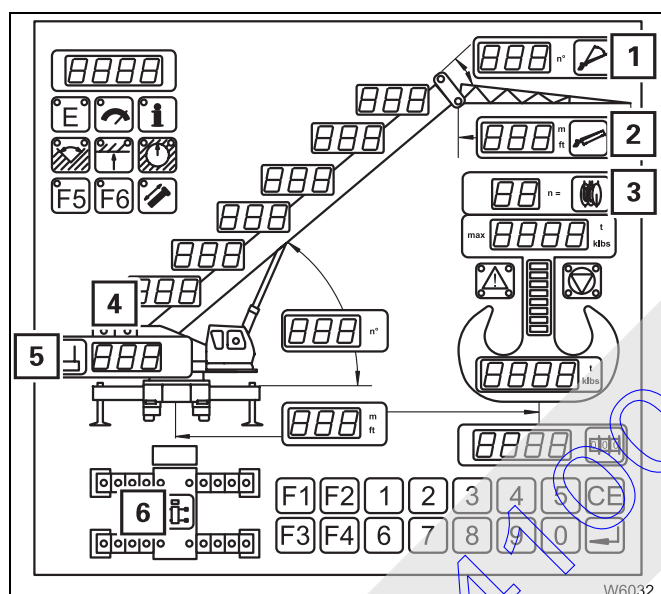

- Check
 - 5 The rigged counterweight
 - 2 The length of the rigged lattice extension
 - 1 The angle of the rigged lattice extension - inclinable
 - 6 The rigged outrigger span
 - 3 The number of reeved rope lines
 - 4 The hoist that is switched on

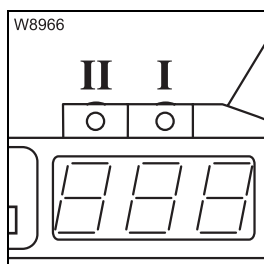

The lamp that goes on must always be for the hoist with which the load is to be lifted.

- Lamp I:** must go on if the load is to be raised with the main hoist.
Lamp II: must go on if the load is to be raised with the auxiliary hoist.

- Switch over the display if necessary; Example of how to switch over the display, p. 12 - 30.

You may only begin operating the crane once all displays show the current rigging mode of the truck crane.
Correct any incorrect entries, as required.



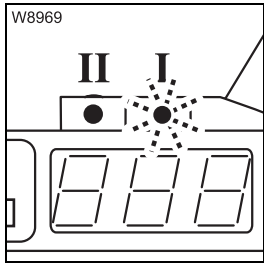

Example of how to switch over the display

The load is to be raised with the main hoist, for example. However, lamp II for the auxiliary hoist goes on and lamp I for the main hoist flashes.

Switch over the display as follows:

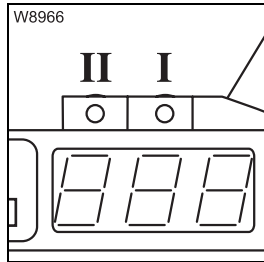

- Switch off both hoists. The lamps I and II go out.

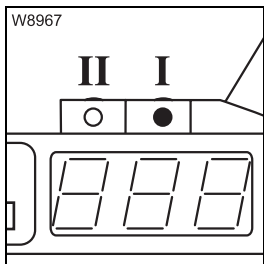

- Switch on the main hoist.
Now the lamp I for the main hoist is on.

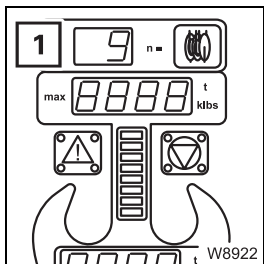

The display (1) now shows the reeving value entered last for the main hoist (e.g. 9).

If no reeving value has yet been entered for this hoist, the SLI selects reeving 1.

- If necessary, enter the current reeving; see p. 12 - 25.



Risk of accidents due to incorrectly set SLI

After switching over the hoists, always check whether the displayed reeving value corresponds to the current reeving value of the displayed hoist and, if necessary, enter the current reeving value.

In this way, you can prevent the SLI from making calculations based on an incorrect reeving value and the truck crane from becoming overloaded or overturning.

12.2.4

Displays during crane operation

Continuous displays

The following information is constantly displayed in addition to the displays of the rigging mode:

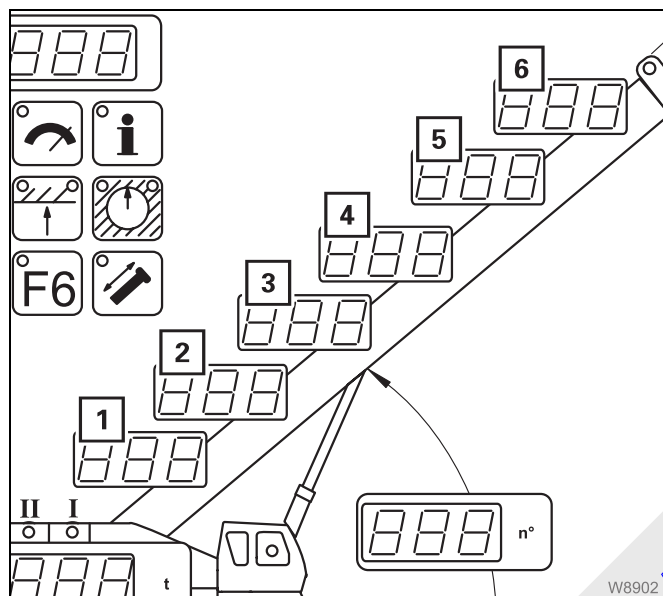

The current telescoping

The displays (1) to (6) show the current telescoping – display (1) for telescope section I, display (2) for telescope section II etc.

- fixed lengths are displayed as decimal values (e.g. **1.00** or **0.50**)
- intermediate and telescoping lengths are displayed in percent (e.g. **100** or **50**).

Surplus displays have no function

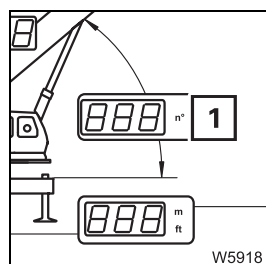

The current main boom angle

The display (1) indicates the current main boom angle in relation to the horizontal. Angles below the horizontal are displayed with a minus sign, e.g. -3° .

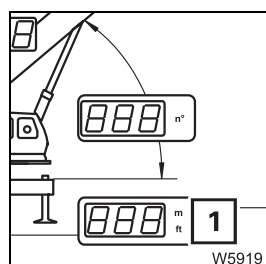

The current working radius

The display (1) shows the current working radius = horizontal distance between the turntable axle and hook block axle. The displayed value is calculated on the basis of the telescoping and the main boom or lattice extension angle. The value is displayed either in metres (m) or feet (ft), depending on the setting.



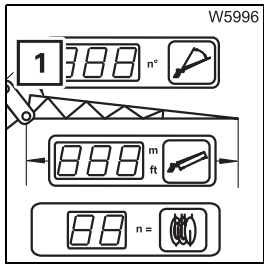

The current lattice extension inclination

- **Lattice extension, derricking:** shows the current lattice extension inclination in relation to the main boom in degrees.
- **Lattice extension, inclinable:** shows the lattice extension angle corresponding to the SLI code in degrees.
- If the displayed SLI code does not apply to a lattice extension, there is no display.

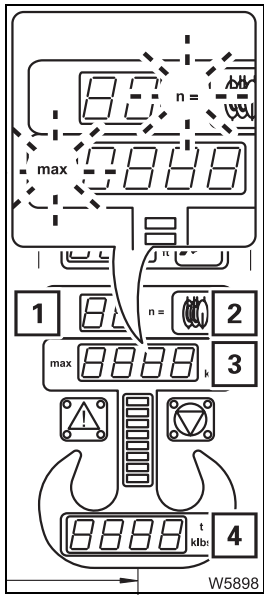

The currently raised load

The display (4) shows the sum of the payload + sling gear + hook block.

The maximum load

The display (3) shows the maximum load that can be lifted in the current rigging mode with the current working radius.

The entry **max** flashes next to the display (3) if the maximum load is reduced by the entered reeving value.

At the same time the unit **n=** flashes next to the display (1).

In this case, you can have the maximum possible load displayed for about three seconds.

- Press button (2) once.
The display (3) shows the maximum possible load that can be lifted with sufficient reeving according to the *Lifting capacity table*.

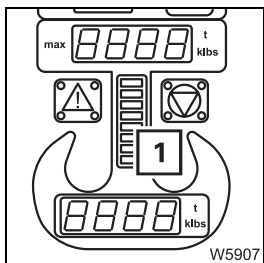

The degree of utilisation

The degree of utilisation shows the weight of the current load as a percentage of the maximum possible load. The coloured lamps (1) for the current degree of utilisation always go on:

- Green:** 0 – 90%
- Yellow:** approx. 90 -100%
- Red:** greater than 100%

The current degree of utilisation can also be displayed as a number;
 p. 12 - 33.

Optional displays

If an error message occurs during the following operation, it is displayed with priority.

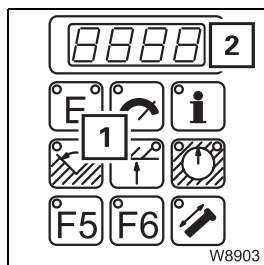

You can call up various types of information on the display (2).

- Press a button on the display field (1).
The display (2) shows the corresponding value until another button is pressed.

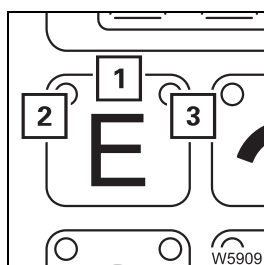

- Displaying error information

The lamps (2) and (3) are on as long as there is an error.
All pending errors can be displayed one after the other by pressing the button (1); *Error message*, p. 12 - 37.

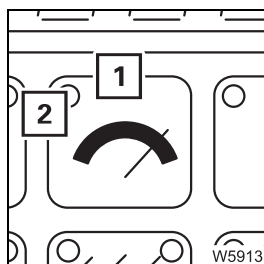

- Displaying the degree of utilization

The lamp (2) goes on and the current degree of utilisation is displayed in percent after pressing the button (1). Definition of the degree of utilization; *Current degree of utilization display*, p. 10 - 87.

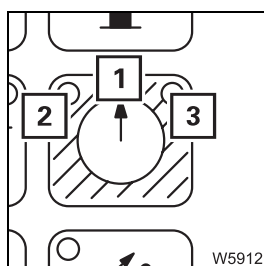

- Displaying current working radius

The lamp (3) has no function.
The green lamp (2) goes on and the current working radius is displayed in percent after pressing the button (1). Definition of the working radius; *The current working radius*, p. 12 - 31.

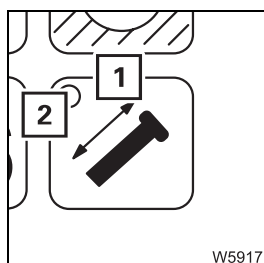

- Displaying the current main boom length

The lamp (2) goes on and the current main boom length is displayed after pressing the button (1). The value is displayed either in metres (m) or feet (ft), depending on the setting.



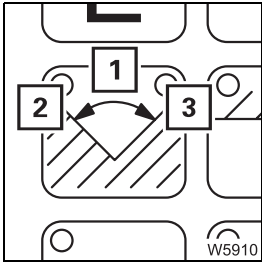

- **Displaying the current slewing angle**

The lamp (3) has no function.

After pressing the button (1), the green lamp (2) lights up, and the current superstructure position is displayed.

0° means that the superstructure is slewed to the rear.

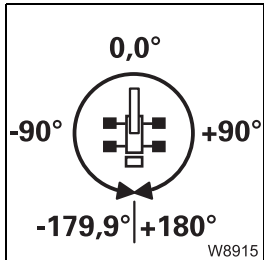

A full turn from this working position is divided into two semi-circles.

- Angles in the **right-hand semi-circle** are displayed as **positive** values (0° to 180.0°).

- Angles in the **left-hand semi-circle** are displayed as **negative** values (0° to -179.9°).

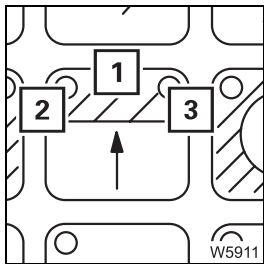

- **Display current overall height**

Overall height = vertical distance between the lower edge of the outrigger pad and the highest point of the main boom or lattice extension.

After pressing the button (1), the lamp (2) lights up, and the current overall height is shown. The value is displayed either in metres (m) or feet (ft), depending on the setting.

The displayed value applies to fully extended support cylinders on the largest outrigger span.

The lamp (3) has no function.

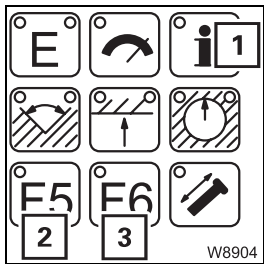

- **Displaying the derricking cylinder oil pressure**

Oil pressure in the derricking cylinder lower chamber:

- Press the button (2) or (3) once.
- Press the button (1) once additionally.

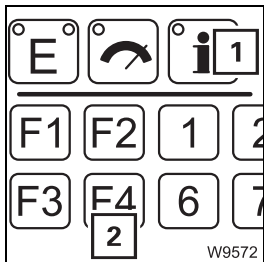

Oil pressure in the derricking cylinder upper chamber:

- Press button (2) once.
- Press the button (1) once additionally.

The lamps in the pressed buttons go on. The corresponding value is displayed in bar.

12.2.5 SLI early warning

If about 90% of the maximum permissible load is exceeded, a SLI early warning is given.

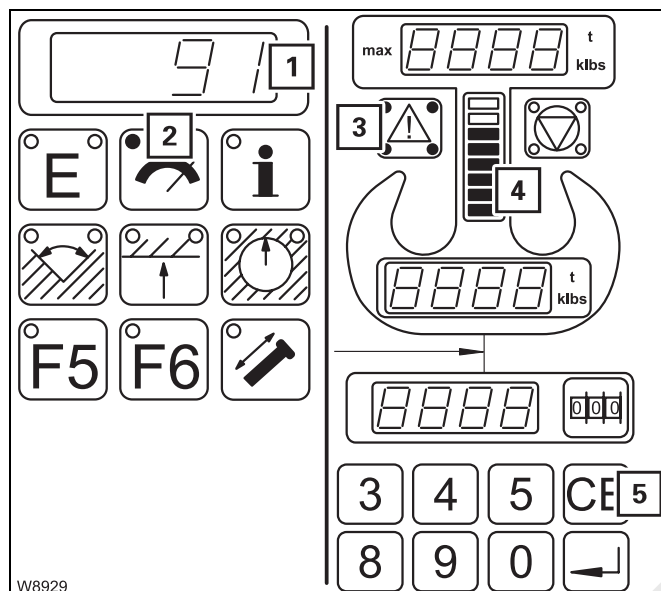

- An intermittent buzzer tone sounds. After five seconds, you can switch off the buzzer tone using the button (5).
- The lamp (3) lights up.
- In the display (4), the **yellow** lamps go on – degree of utilisation 90 – 100%.
- Press the button (2) once for the exact value of the degree of utilisation. The display (1) shows the current degree of utilisation, e.g. 91%.



If the current crane movements continue to be carried out in the same direction, an SLI shutdown occurs.

12.2.6

SLI shutdown

There are different types of SLI shutdowns:

- shutdown due to overload,
- shutdown due to an error message; ■■■► p. 12 - 37.

Shutdown due to overload

If about 100% of the maximum permissible load is exceeded, shutdown occurs due to overload.

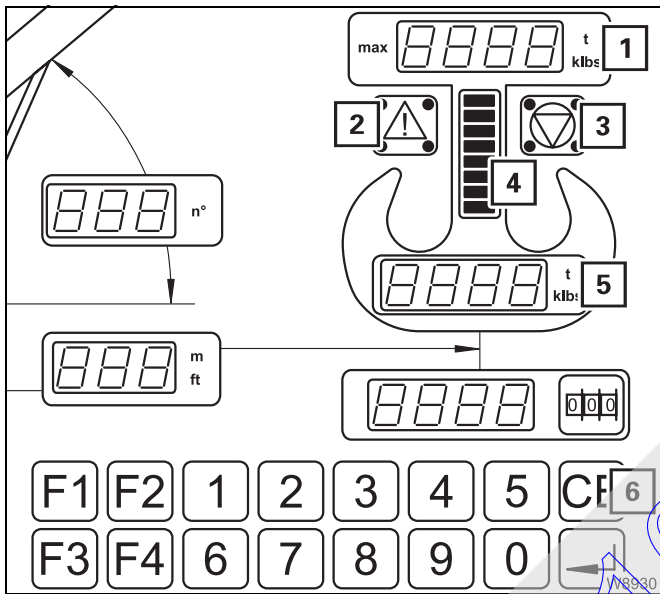

- All crane movements that increase the load moment are switched off.
- A continuous buzzer tone sounds. After five seconds, you can switch off the buzzer tone using the button (6).
- Lamps (2) and (3) light up.
- In the display (4), the red lamps light up – degree of utilisation approx. 100%.
- The value on display (5) is the same or greater than the value on display (1).

Cancelling a shutdown

- If you have not yet switched off the buzzer tone, press the button **CE** once.
- Leave the shutdown range by carrying out the crane movements according to the following table.

Deactivated crane movements	Permitted crane movements
Lifting loads	Lowering loads
Lowering the main boom	Raising the main boom
Extending the main boom	Retracting the main boom ¹⁾
Lowering the lattice extension	Raising the lattice extension



- ¹⁾ In some cases the SLI also switches off boom retracting. In this case, leave the shutdown range by raising the boom. If this is not possible, set down the load, telescope to the next fixed length and raise the load again.

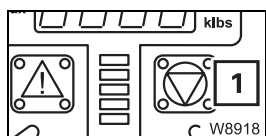

If you have left the shutdown range, the lamp (1) goes out.
The crane movements are now enabled.

12.2.7

Error message

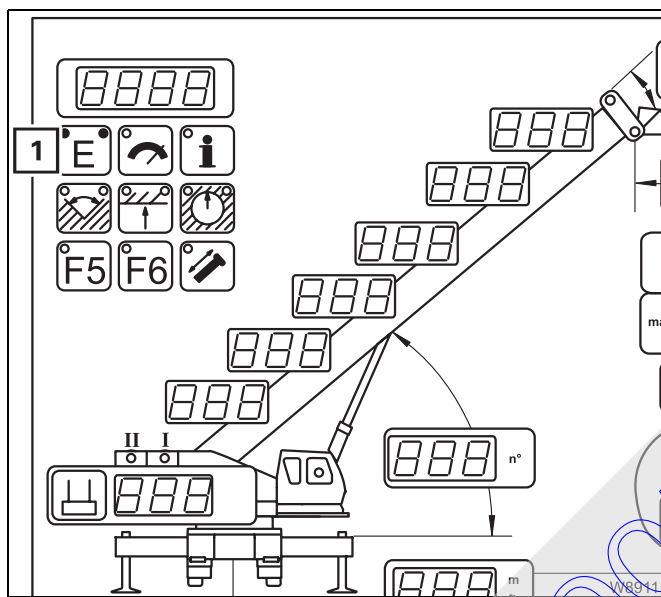

If an error occurs, it is displayed as follows:

- depending on the type of error, the buzzer tone sounds once or as a continuous buzzer tone.
- both lamps in the button (1) light up.

Further displays depend on the type of error;
▶ *Error messages*, p. 15 - 26.

12.2.8**SLI override**

If the SLI is overridden, crane operation is not monitored, and deactivated crane movements are re-enabled.

**Risk of accidents due to overridden or faulty SLI**

It is not permitted to work with an overridden or faulty SLI.

Set down the load immediately and stop operating the crane if the SLI is faulty.

You may only override the SLI if it becomes absolutely necessary in the event of an emergency. This is to put the truck crane into a safe condition in the event of a malfunction. In this case, do not perform any movements that would increase the load moment.

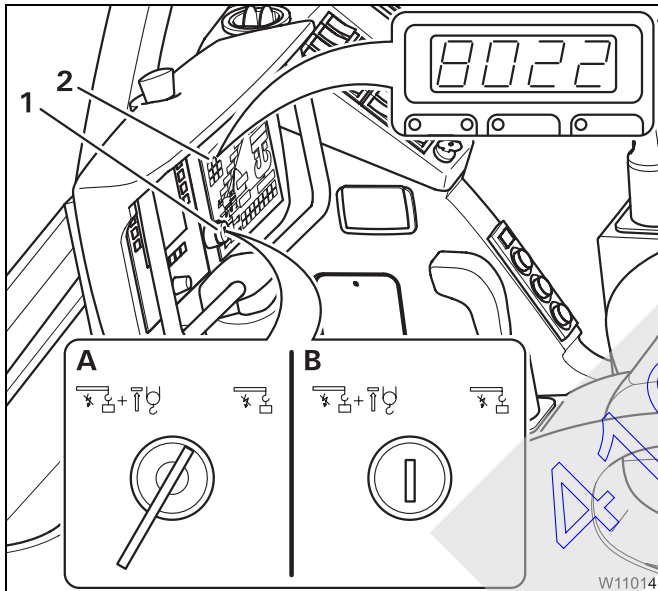
**Overriding the SLI**

- Insert the key into the key-operated switch (1).
- (A) – Turn the key to the right and hold it in this position.

The display (2) shows the error message **8022**.

Cancelling the override

- (B) – Let go of the key.
- Remove the key.
- Press the button **CE** once, the error message is acknowledged.

**Risk of accidents due to accidental override**

The key must not remain in the key-operated switch when operating the crane. In this way, you avoid accidentally overriding the SLI.



The SLI can also be overridden together with the lifting limit switch;
 ■► p. 12 - 52.

12.2.9

Displaying and entering the time and date

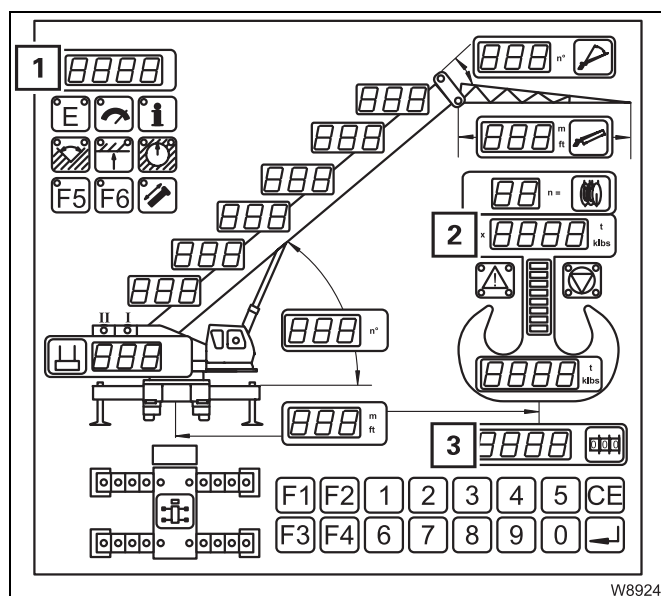

On the display (1), you can

- display the time and date and
- enter the time and date.

On the displays (2) and (3), input mode must not be switched on.

Display

The buttons for the display are assigned as follows.



6 – Display of the **time**, e.g. 8 minutes past 9



7 – Display of the **seconds**, e.g. 14 seconds

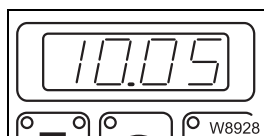

8 – Display of the **day and month**, e.g. 10 May

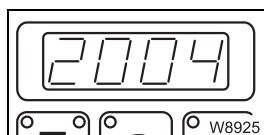

9 – Display of the **year**, e.g. 2004



Input

You can abort the following input procedure at any time by pressing the button **CE**.

Assuming that you would like to enter the time as 9:08 and 14 seconds, and the date as 10 May 2004.

- Using the button **6**, **7**, **8** or **9**, call up the display that you wish to change and enter the new value in the following way:

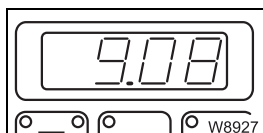

– **Entering the time**

- Press **F1** + **6**. The number 0 flashes.
- Press the buttons **9** **0** **8** one after the other.

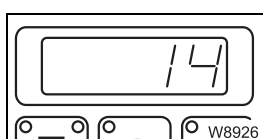

– **Entering the seconds**

- Press **F1** + **6**. The number 0 flashes.
- Press the buttons **1** **4** one after the other.

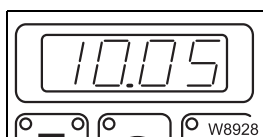

– **Entering the day and month**

- Press **F1** + **6**. The number 0 flashes.
- Press the buttons **1** **0** **0** **5** one after the other.

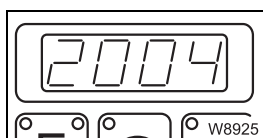

– **Entering the year**

- Press **F1** + **6**. The number 0 flashes.
- Press the buttons **2** **0** **0** **4** one after the other.

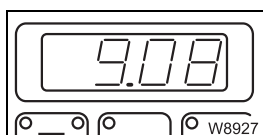

- Press **CE** once.

The entry is confirmed. The display no longer flashes but indicates the new entry, e.g. 9:08.



Illogical values (77 seconds for example) are not saved and the display continues to flash.

12.3

Crane operation with main boom

12.3.1

Checks during crane operation

Horizontal alignment

During crane operation the truck crane may become inclined if the ground gives way due to varying loads.



Risk of accidents if the truck crane is not level

The SLI calculates the radius from the length and angle of the main boom. The actual working radius changes and there is a danger of the crane overturning if the truck crane is not level.

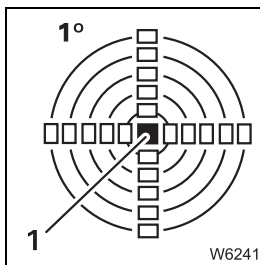

- Check the truck crane for horizontal alignment during crane operation on the display (1); p. 13 - 46.

Due to deformation of the frame, the horizontal alignment can change by up to 2° when the superstructure is turned from the 0° or 180° position. If the truck crane does not return to the horizontal position after being turned back to the 0° or 180° position, you must immediately determine the cause and eliminate it and, if necessary, realign the crane. Observe the position of the superstructure when doing so; *Levelling the truck crane on outriggers*, p. 13 - 46.

Safe distances

During crane operation, always ensure that the truck crane and the load are at a sufficiently large distance to objects and persons. Pay particular attention to objects that pose a direct risk (e.g. scaffolding or gas containers).

Keep a safe distance to electrical lines; *Safe distance from electrical lines*, p. 13 - 14.



Checking the wind speed

Strong winds can result in the truck crane becoming overloaded.

- Prior to and during crane operation, check whether the actual wind speed is lower than the maximum permissible wind speed.

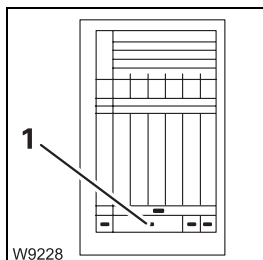

Maximum permissible wind speed

The maximum permissible wind speed (1) for the current rigging mode is specified at the bottom of the corresponding *Lifting capacity table*.

In certain cases, the specified permissible wind speed must be reduced;  *Lifting capacity table*.

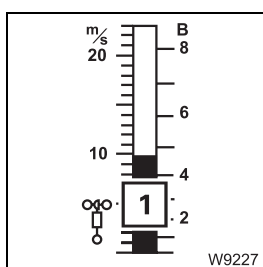

Current wind speed

The current wind speed is displayed in the main menu and in the *Telescoping* submenu. The bar (1) changes colour, depending on the range displayed:

- 0 to 6 m/s: green bar
- 6 to 12 m/s: yellow bar
- Over 12 m/s: red bar



The colour of the bar depends only on the value of the current wind speed. The maximum permissible wind speed does not affect the colour of the bar.

If an anemometer is not available or in the event of a fault, you can find out which speeds have been forecasted from the respective weather stations.

The *lifting capacity table* contains an overview of the wind strengths, wind speeds and their effects.

If the maximum permitted wind speed is exceeded

No automatic shutdown occurs if the maximum permissible wind speed is exceeded.

- Immediately stop crane operation.
- Bring the truck crane into the rigging mode specified for the current wind speed given by the *Lifting capacity table*.



Risk of accidents due to excessively high wind speeds

If the current wind speed is higher than the maximum permissible wind speed, stop crane operation immediately and establish the corresponding rigging mode *Lifting capacity table*.



This prevents the truck crane from overturning due to overloading.

12.3.2



Permissible slewing ranges and working positions

The following ranges are permissible for crane operation according to the *Lifting capacity table*.

360° slewing range



- Support the truck crane with the outrigger span required according to the *Lifting capacity table*.
- Enter an SLI code for the 360° slewing range according to the *Lifting capacity table*;  *Entering the rigging mode*, p. 12 - 21.
- Rig a counterweight version that is no larger than that permitted for the rigged outrigger span. Slewing with a rigged counterweight is not permitted with all outrigger spans;  *Slewing with rigged counterweight*, p. 13 - 82.
- Slewing is not permissible if the truck crane is free-on-wheels;  *Free-on-wheels working position*, p. 12 - 44.

0° to the rear working position

- Support the truck crane with the outrigger span required according to the *Lifting capacity table*.
- Slew the superstructure to the rear into the 0° position. For automatic stoppage at 0°;  *Slewing to 0° or 180°*, p. 12 - 90.
- Switch off the slewing gear;  p. 12 - 92.
- Enter an SLI code for the 0° to the rear working position according to *Lifting capacity table*;  *Entering the rigging mode*, p. 12 - 21.
The SLI only accepts this code when the slewing gear has been switched off and the superstructure is in the 0° position.



All slewing operations are disabled if an SLI code is entered for the 0° to the rear working position. An SLI shutdown is triggered if you switch on the slewing gear. To acknowledge the shutdown, you must:

- either shut down the slewing gear
 - or, if slewing is permissible with the rigged counterweight ( p. 13 - 82), set down the load and enter an SLI code for the 360° slewing range.
- Observe the additional information if the truck crane is free on wheels;  *Free-on-wheels working position*, p. 12 - 44.



180° to the front rigging position

The same lifting capacity tables and SLI codes apply to this position as to the 360° slewing range.

Free-on-wheels working position

The superstructure may not be slewed in the *Free-on-wheels* working position.



Danger of overturning if the truck crane is free on wheels

The superstructure may not be slewed when the truck crane is free on wheels.

If an SLI code has been entered for the *Free-on-wheels* working position, then the crane movements will only be enabled if the slewing gear is switched off. Do not override the SLI.

This prevents the truck crane from overturning when slewing.

Prior to entering an SLI code for the *Free-on-wheels working position* you have to:

- support the truck crane,
 - rig the required counterweight combination,
 - slew the superstructure into the *0° to the rear* position,
 - shut down the slewing gear,
 - put the truck crane on the wheels.
- Proceed as described in the section titled Rigging in free on wheels working position; ►► p. 113 - 111.

12.3.3

Main hoist

You can reeve the hoist rope of the main hoist on the main boom or on the lattice extension.



Risk of accidents from accidentally operating a hoist

Always switch off the hoist that is not in use.

Never operate the hoist if the hook block is unreeved and the hoist rope is completely wound onto the drum.

- Slack rope forms in the course of the *Lower* movement. Rope loops form, which can cause the load to slip and destroy the hoist rope.
- The switch-off point of the lowering limit switch shifts in the course of the *Raise* movement. The lowering limit switch loses its function as a safety device.



Risk of accidents when raising loads at a slant

Loads can bend the main boom, resulting in the hoist rope no longer being aligned in a vertical position. Compensate the deflection by lowering the boom in order to raise the load vertically. In this way, you can prevent the load from dragging and helpers from being injured.

Inform all helpers about this issue.



Danger posed by rope slack

Only use hook blocks and sling gear of the minimum weight prescribed in the *Lifting capacity table*, depending on the reeving and boom length. That way you prevent slack rope developing at large heights when lifting without a load. This can result in the load slipping during subsequent lifting procedures.

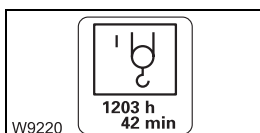

You can have the operating hours of the hoist displayed; ■■■► p. 12 - 101.



Switching on the main hoist

All power units are switched off and the lamps in the corresponding buttons light up only dimly after turning on the ignition.

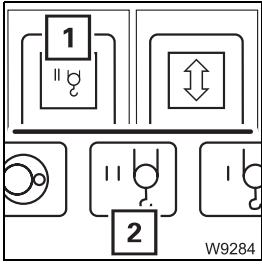

- Check whether the auxiliary hoist is switched off and therefore secured against unintentional operation.
 - The lamp in the button (1) should only light up dimly.
 - The symbol (2) must be **red**.

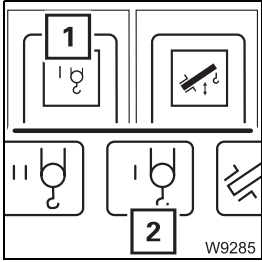

- Press button (1) once.
 - The lamp in button (1) lights up brightly.
 - Symbol (2) is **green** when the main hoist is switched on.

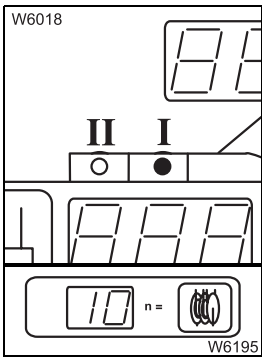

- On the SLI, check whether the lamp **I** is on. When the lamp **I** flashes, switch the display over; p. 12 - 30.
- Check whether the current reeving of the main hoist is displayed, e.g. **10**. Correct the reeving if necessary; p. 12 - 25.

Lifting and lowering

You can adjust the sensitivity of the control levers to the operating conditions; *Setting the characteristic curve for the control levers*, p. 12 - 98.



Risk of accidents due to incomplete monitoring

- Operation of the hoist is only monitored fully if
- the lifting limit switch is correctly installed; p. 13 - 102,
 - the lifting limit switch is not overridden; p. 12 - 51,
 - the lowering limit switch is correctly set; p. 12 - 51.



Risk of accidents due to suspended loads

Never turn off the engine with a load suspended. You must have the control levers at hand in order to intervene at any time. Always set down the load before you leave the crane cab.

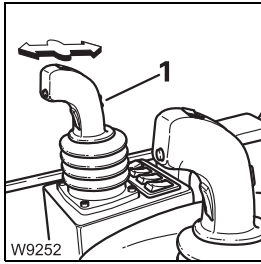

- To lift:**
- pull the control lever backwards.
- To lower:**
- push the control lever forwards.

When the hoist drum is turning, you will notice an impulse on the slewing indicator (1).

You can regulate the speed by moving the control lever and changing the engine speed with the accelerator.

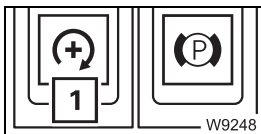

You can set the desired engine speed (idling speed) with the button (1);
 ■■■▶ p. 11 - 16.

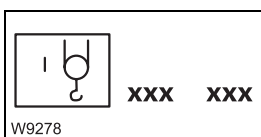

You can limit the maximum hoist speed; ■■■▶ p. 12 - 96.

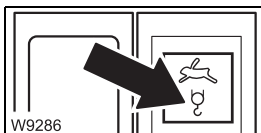

For higher speeds, you can also switch to high-speed mode; ■■■▶ p. 12 - 86.

Switching off the main hoist

If you no longer require the main hoist, you should switch it off to avoid unintentional use.

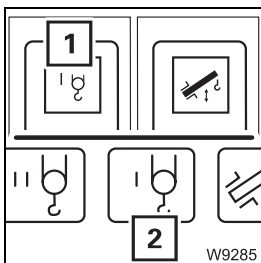

- Press button (1) once.
 - The lamp in the button (1) lights up dimly.
 - Symbol (2) is **red** when the main hoist is switched off.

12.3.4

Auxiliary hoist

You can reeve the hoist rope of the main hoist on the main boom or on the lattice extension.



Danger of accidents when operating the auxiliary hoist

Read and observe all of the safety instructions in the section titled *Main hoist*, p. 12 - 45 before operating the auxiliary hoist.

All of the safety instructions for the operation of the main hoist also apply to the auxiliary hoist, along with the information in this section.



Danger of accidents due to a damaged hoist rope

If you reeve the auxiliary hoist rope in addition to the main hoist rope, make sure the hoist ropes do not rub against each other and that the auxiliary hoist rope does not touch the rotating flanged wheel of the main hoist.

Raise the main boom to at least 20° before lifting loads.

This prevents damage to the hoist ropes, resulting in the ropes tearing.



If you run the auxiliary hoist rope over the left head sheave, you must extend a telescopic section to the middle fixed length before lifting a load. Otherwise, the rope angle would exceed the maximum permissible value.

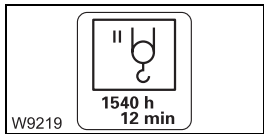

You can have the operating hours of the hoist displayed; see p. 12 - 101.

Switching on the auxiliary hoist

All power units are switched off and the lamps in the corresponding buttons light up only dimly after turning on the ignition.

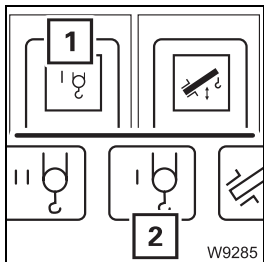

- Check whether the main hoist is switched off and therefore secured against unintentional operation.

- The lamp in the button (1) should only light up dimly.
- The symbol (2) must be **red**.

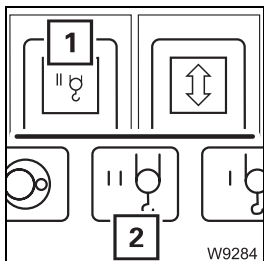

- Press button (1) once.
- The lamp in button (1) lights up brightly.
- Symbol (2) is **green** when the auxiliary hoist is switched on.

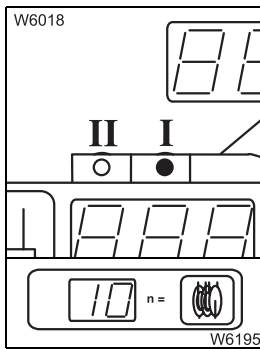

- On the SLI, check whether the lamp **II is on**.
When the lamp **II flashes**, switch the display over; p. 12 - 30.

- Check whether the current reeving of the auxiliary hoist is displayed, e.g. **10**. Correct the reeving if necessary; p. 12 - 25.

Lifting and lowering

You can adjust the sensitivity of the control levers to the operating conditions; *Setting the characteristic curve for the control levers*, p. 12 - 98.



Risk of accidents due to incomplete monitoring

- Operation of the hoist is only monitored fully if
- the lifting limit switch is correctly rigged; p. 13 - 102
 - the lifting limit switch is not overridden, p. 12 - 51
 - the lowering limit switch is correctly set; p. 12 - 51.



Risk of accidents due to suspended loads

Never turn off the engine with a load suspended. You must have the control levers at hand in order to intervene at any time.
Always set down the load before you leave the crane cab.

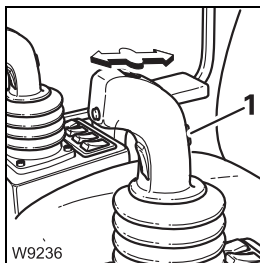

- To lift:** • pull the control lever backwards.
To lower: • push the control lever forwards.

When the hoist drum is turning, you will notice an impulse on the slewing indicator (1).

You can regulate the speed by moving the control lever and changing the engine speed with the accelerator.

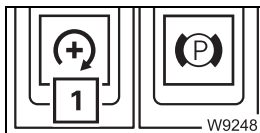

You can set the desired engine speed (idling speed) with the button (1); p. 11 - 16.



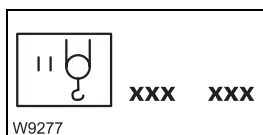

You can limit the maximum hoist speed;  p. 12 - 96.

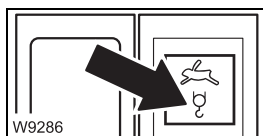

For higher speeds, you can also switch to high-speed mode;  p. 12 - 86.

Switching off the auxiliary hoist

If the auxiliary hoist is not required, it should be switched off to avoid unintentional use.

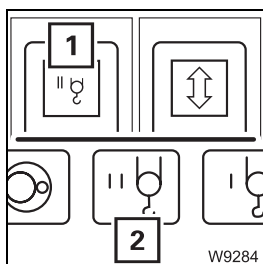

- Press button (1) once.
 - The lamp in the button (1) lights up dimly.
 - Symbol (2) is **red** when the auxiliary hoist is switched off.

41005067

12.3.5

Lifting limit switch and lowering limit switch

Lifting limit switch

To install / dismantle the lifting limit switch;  p. 13 - 102.

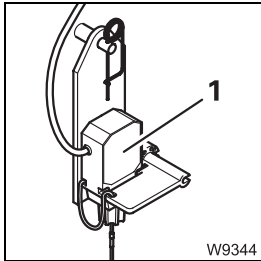

The lifting limit switch (1) prevents the hook block from being lifted up to the main boom head and damaging it.

The lifting limit switch only works if it has been unlocked;  p. 13 - 107.



Danger of accidents due to intentional triggering of the lifting limit switch

Always complete the hoisting operation (and extending) before raising the lifting limit switch. If the lifting limit switch is lifted at too great a speed, the hook block may swing into the main boom head and damage the head sheaves and the hoist rope.

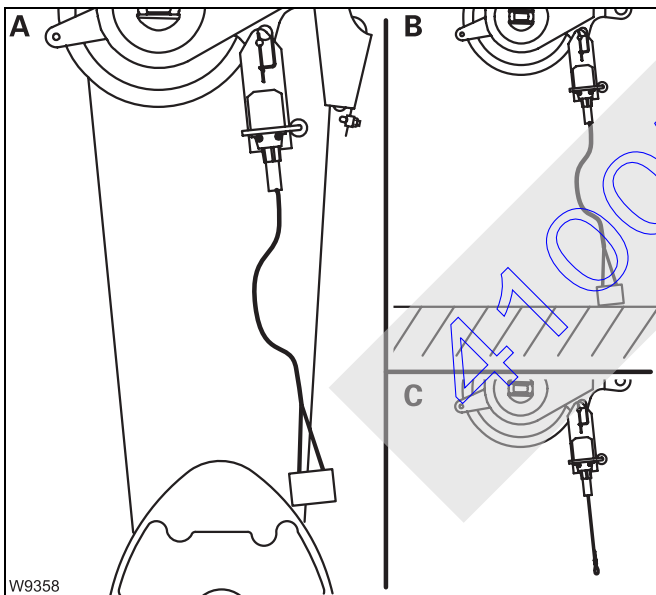

The lifting limit switch is triggered if

(A) – the hook block raises the lifting limit switch weight or

(B) – the lifting limit switch weight touches the ground upon lowering or

(C) – the lifting limit switch weight is not attached.

The lifting limit switch is not triggered when it is locked.

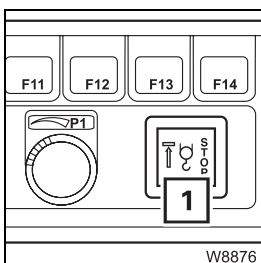

The lamp (1) lights up if the lifting limit switch has been triggered.

At the same time all load moment increasing movements are switched off – *lifting, lowering, extending and derricking the lattice extension.*

To cancel the shutdown, leave the shutdown range by performing a different crane movement or setting down the load.



Lifting limit switch shutdown

When overriding, the deactivation of the lifting limit switch is cancelled and crane operation is no longer monitored completely.

You can only override the lifting limit switch together with the SLI.



Risk of accidents if the lifting limit switch is overridden

You may only override the lifting limit switch if required to do so by with the operating instructions when carrying out maintenance or rigging work. With the lifting limit switch overridden, you may drive at minimum speed and without a load.



Risk of accidents due to incomplete monitoring

If the lifting limit switch is overridden, crane operation is no longer monitored completely.

When hoisting the lifting limit switch weight, the crane movement is stopped once. After moving the control lever again, the crane movement is re-enabled and thereafter not disabled again.

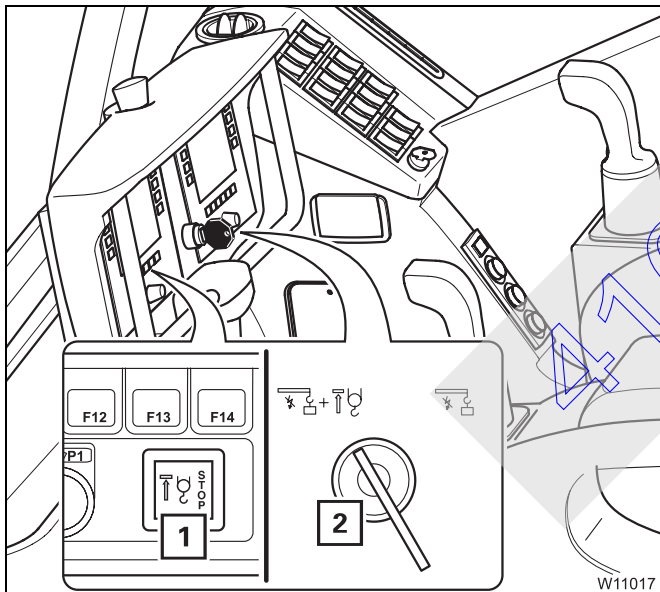

- Insert the key into the key-operated switch (2).
- Turn the key to the left. The lifting limit switch and the SLI are overridden until you let go of the key.

If the lifting limit switch is triggered now, the crane movement is stopped **once** and the lamp (1) flashes.

The stopped crane movement is re-enabled if you put the control lever into zero position and then move it again.

This crane movement will now not be stopped again.

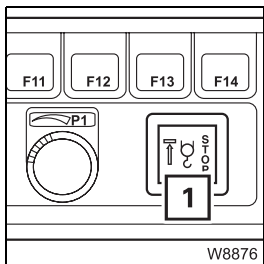

The lamp (1) goes out

- if you let go of the key-operated switch (override cancelled) or
- if you leave the shutdown range.

Lowering limit switch

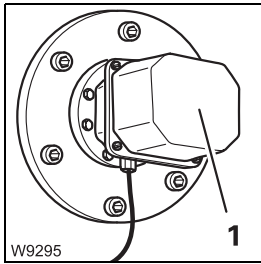

The lowering limit switch (1) prevents the hoist rope from being reeled off the drum completely.

The lowering limit switch only works if the switch-off point is set correctly (e.g. after changing a hoist rope);  *Maintenance manual*.



Risk of accidents due to incorrect setting or intended triggering

Prior to crane operation, ensure that the lowering limit switch is set correctly and always complete the lowering operation before the lowering limit switch is triggered.

This prevents the hoist rope from becoming damaged due to complete unreeling or switching off at high speeds, and the load being dropped as a result.



Risk of accidents due to adjustments made to the lowering limit switch

Always re-adjust the lowering limit switch if you unreel hoist rope from the stationary rope drum. The lowering limit switch does not record the number of these winds.

In this way you avoid the lowering limit switch switching off too late or not at all, the hoist rope being damaged and the load being dropped.

12.3.6

Derricking gear

You can raise and lower the main boom.

Depending on the size of the load and the rigging mode, the SLI switches off the lowering process of the boom as soon as the working area specified in the *Lifting capacity table* is left.

To lower the boom out of the working range;  *Lowering the main boom to a horizontal position*, p. 12 - 56.



Danger of overturning when lifting loads

It is prohibited to lift loads by raising the boom, since the SLI does not monitor this procedure.



Raising the boom is a movement that reduces the load moment and that is not deactivated by the SLI. However, raising the boom is the movement which can cause the truck crane to overturn if the load lifted is too heavy.



You can have the operating hours of the derricking gear displayed;  p. 12 - 101.

Switching on the derricking gear

All power units are switched off and the lamps in the corresponding buttons light up only dimly after turning on the ignition.

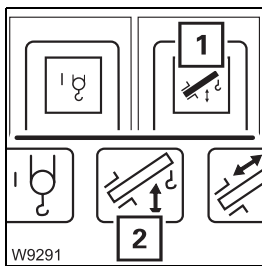

- Press button (1) once.

- The lamp in button (1) lights up brightly.
- The symbol 2 is **green** if the derricking gear is switched on.

If the control lever is assigned more than one function, all other power units which are assigned the same control lever operation are switched off;

 *Control lever assignment*, p. 10 - 16.

Raising and lowering the boom

You can adjust the sensitivity of the control levers to the operating conditions;  *Setting the characteristic curve for the control levers*, p. 12 - 98.



Risk of accidents due to unexpected crane movements

In the case of multiple configuration, check whether the control lever function *Derricking* is switched on before you move the control lever for derricking.

This way, you avoid accidents due to unexpected crane movements.

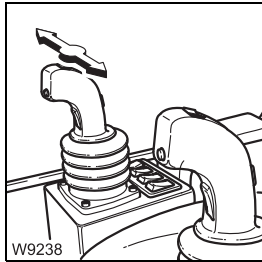

To lower:

- push the control lever to the right – the main boom is lowered.

To raise:

- push the control lever to the left – the main boom is raised.

You can regulate the speed by moving the control lever and changing the engine speed with the accelerator.



The maximum derricking speed is automatically reduced as the system length is increased. If you now reduce the working radius (e.g. by retracting the telescoping), the derricking speed is automatically increased again.

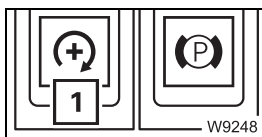

You can set the desired engine speed (idling speed) with the button (1);  p. 11 - 16.

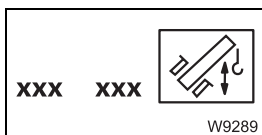

You can limit the maximum derricking speed;  p. 12 - 96.



For higher speeds, you can also switch to high-speed mode;  p. 12 - 86.



Switching off the derricking gear

If the derricking gear is not required, it should be switched off to avoid unintentional use.

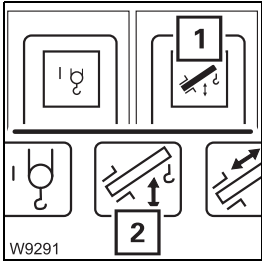

- Press button (1) once.
 - The lamp in the button (1) lights up dimly.
 - The symbol (2) is (red) if the derricking gear is switched off.

In the case of multiple configuration of the control lever, the derricking gear is also switched off if you switch on another power unit which is assigned the same control lever movement;  *Control lever assignment*, p. 10 - 16.

Lowering the main boom to a horizontal position

Lowering the boom out of the working range is only released without a load and if there is a rigging table for the current rigging mode. Releasing is automatic, the rigging tables cannot be entered manually. The same tables apply to raising outside of the working range.

- Set down the load.



Danger of overturning with overridden SLI

Do not under any circumstances override the SLI. If the SLI shuts down the lowering procedure, the truck crane is in a condition in which the main boom may not be lowered beyond the working range (e.g. the load or working radius is too large). The truck crane will overturn if you continue to lower the boom with the SLI overridden.

- Lower the main boom.

The SLI switches off the lowering procedure at about 10 - 15° if there are no rigging tables for the current rigging mode. In this case you must bring the crane into a rigging mode for which a rigging table exists (e.g. retracting, setting down the load, other superstructure position).

All rigging modes for which rigging tables exist can be found in the *Lifting capacity tables*.

12.3.7

Telescoping mechanism

A telescoping process requires locking and unlocking processes in the main boom. You can telescope the main boom in two ways.

– **Manual telescoping**

For manual telescoping, you must initiate all locking and unlocking processes at the right point in time.

– **Telescopic extension with teleautomation**

When telescoping with teleautomation, you enter a telescoping and ECOS controls all the locking and unlocking processes automatically. You may additionally need to telescope to an intermediate length manually.

With both ways, operation is performed on the control unit in addition to the control levers *ECOS*. Here you initiate processes, receive feedback and can monitor the telescoping process.

The *ECOS* display shows various sectional views of the main boom. To make you familiar with these representations more quickly, the following section begins with an overview of the telescoping mechanism and a telescoping process.



Overview

The illustration shows the completely retracted main boom with the basic section (9) and the first three telescopic sections I to III (1) to (3).

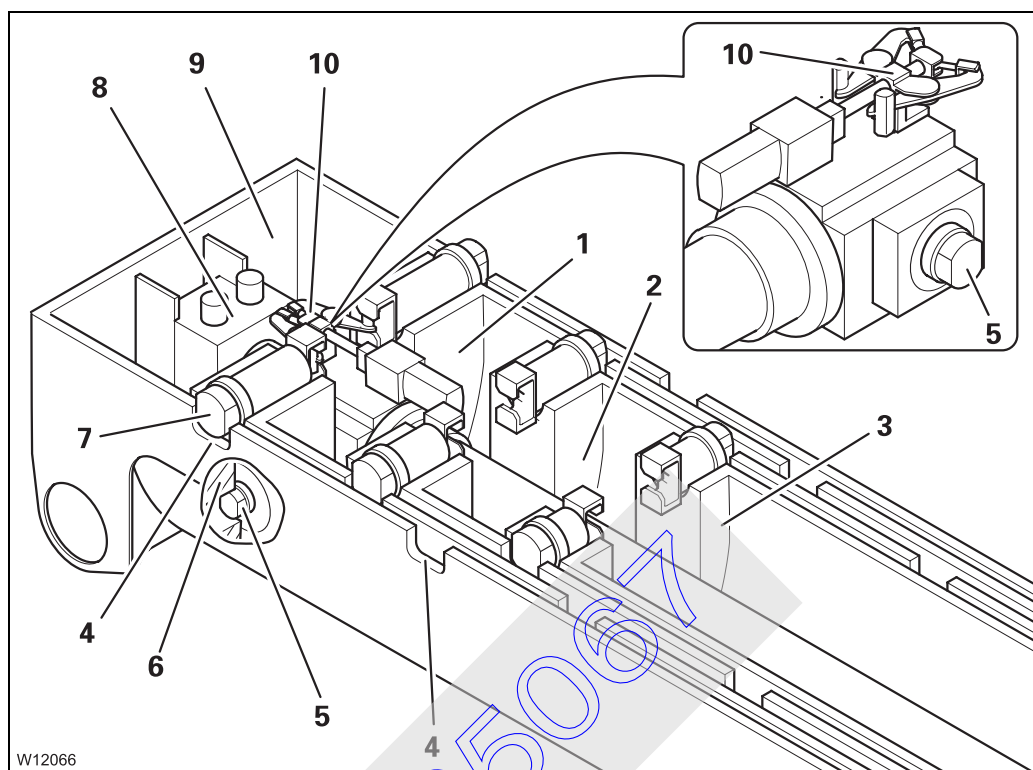

Each telescopic section is equipped with two locking pins (7) which are extended by spring force.

The locking pins (7) are pushed into the cutouts (4) of the telescopic section above at the locking points – the telescopic section is locked.

The telescoping cylinder is attached to the basic section (9) with the piston rod (8). The telescoping cylinder has two locking pins (5) at the bottom and a mechanism at the top (10).

When the telescoping cylinder is positioned at a locking point:

- then the locking pins (5) can be extended into the cutouts (6) – the telescoping cylinder is locked
- then the mechanism (10) engages into the locking pins (7) and can retract them – the telescopic section is unlocked.

Telescoping process

This condition should be the starting point for a telescoping process. Telescoping processes consist of 4 steps:

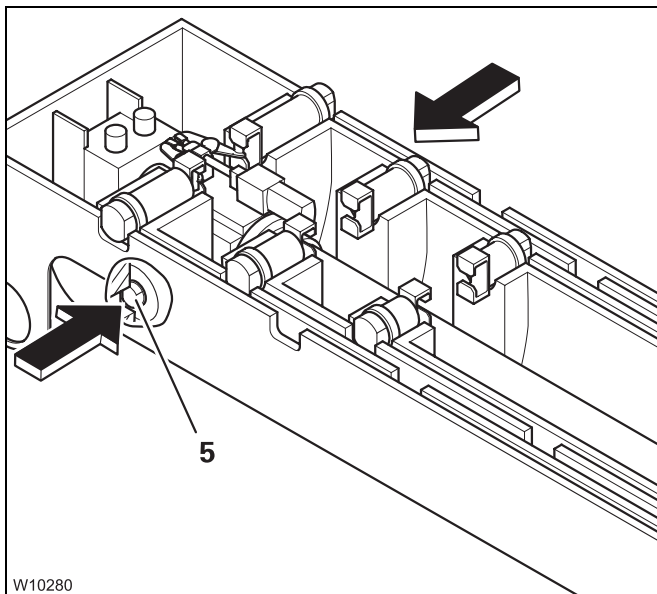

1. Unlocking the telescoping cylinder

The locking pins (5) retract – the telescoping cylinder is unlocked.

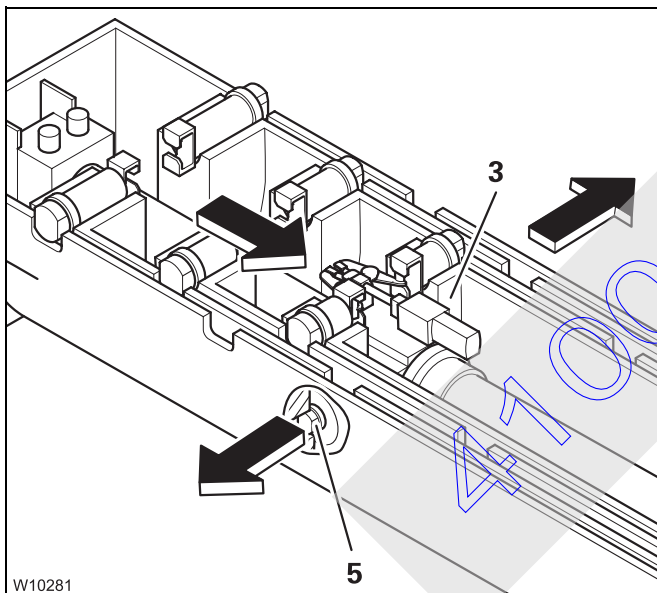

2. Moving and locking the telescoping cylinder

The telescoping cylinder moves into the telescopic section to be telescoped, e.g. telescopic section III (3).

The locking pins (5) extend – the telescoping cylinder is locked.

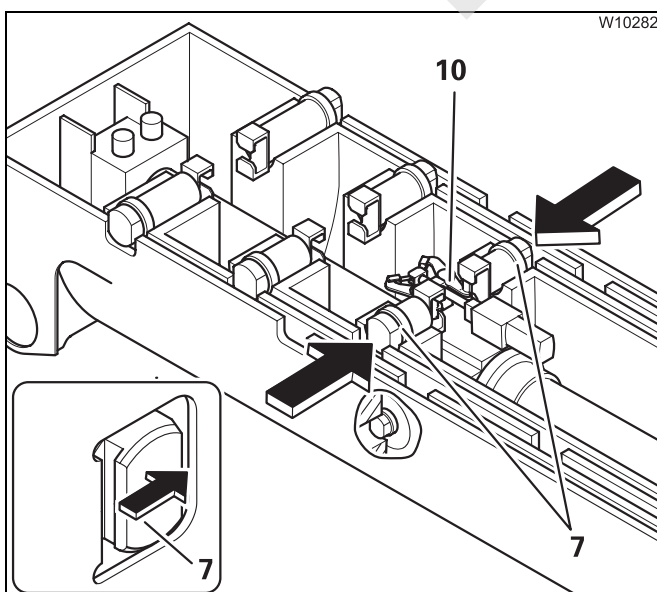

3. Unlocking the telescopic section

The telescoping cylinder extends until the locking pins (7) are clear.

The mechanism (10) retracts the locking pins (7) – the telescopic section is unlocked.



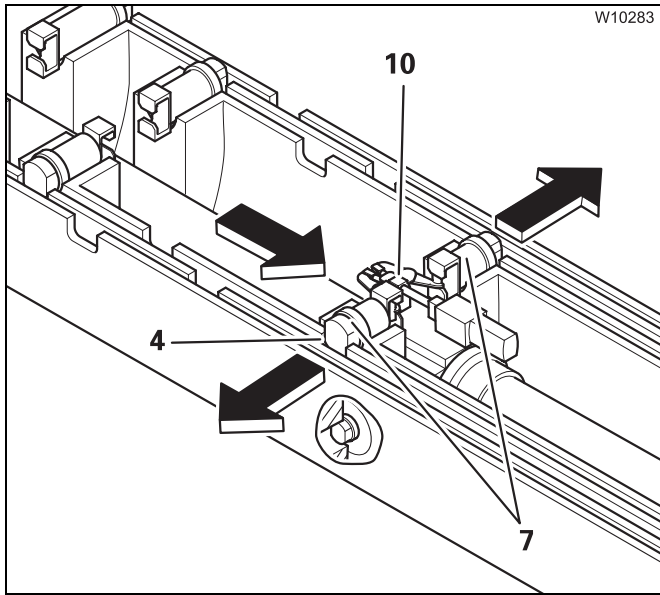

4. Telescoping, locking and setting down a telescopic section

The telescoping cylinder pushes the telescopic section to a locking point.

The weight is taken off the mechanism (10).
The locking pins (7) extend into the cutouts (4).

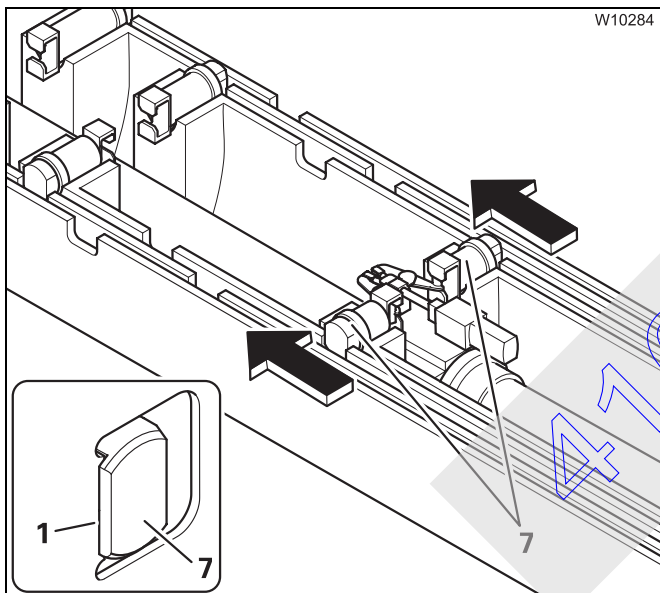

The telescopic section is automatically set down.

The telescopic cylinder retracts until the locking pins (7) are positioned on the above telescopic section (1).

The weight of the load is now on the telescopic sections and not on the telescoping cylinder.

Assignment for display

The *Telescoping* submenu of the *ECOS* display shows two sectional views of the main boom.

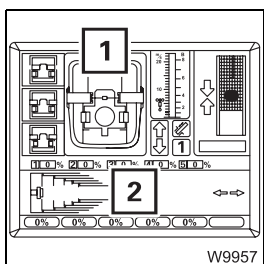

- 1 Sectional view from the rear
- 2 Sectional view from the front

The following elements are displayed.

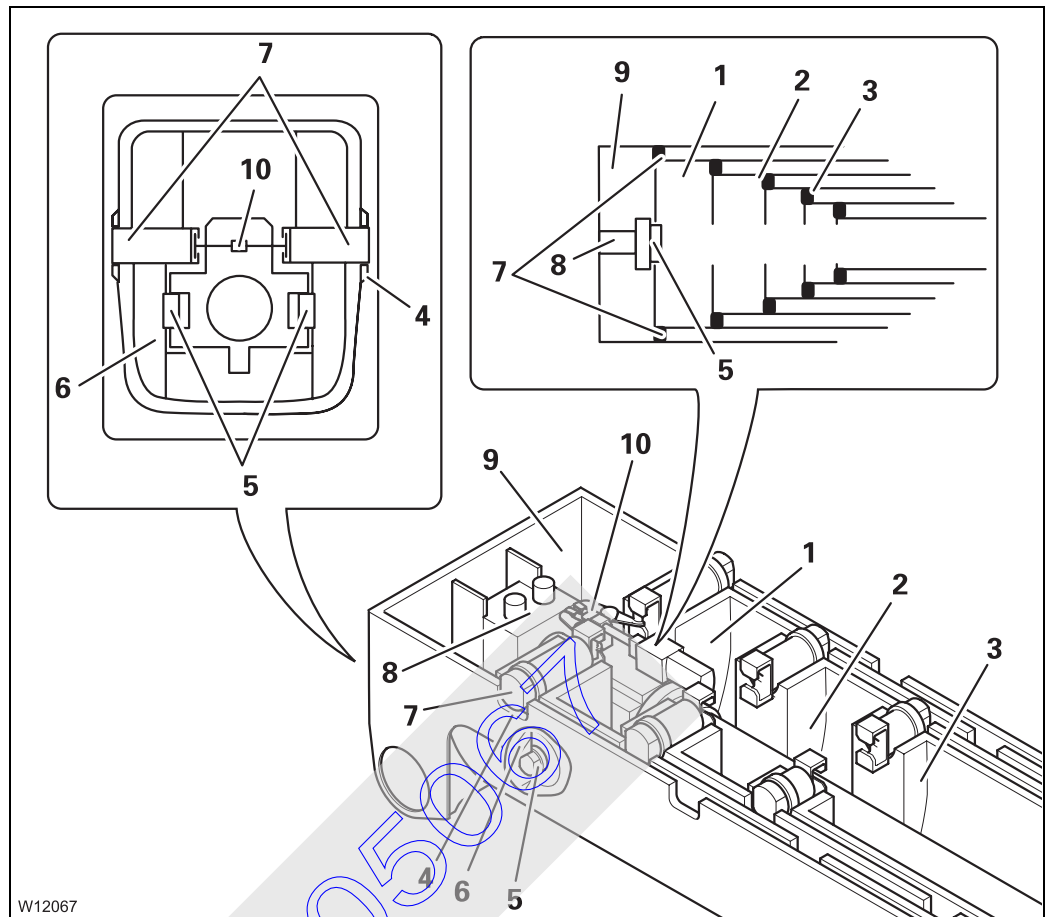

W12067

- 1 Telescopic section I
- 2 Telescopic section II
- 3 Telescopic section III
- 4 Cutouts
- 5 Locking pins on the telescoping cylinder
- 6 Cutouts
- 7 Locking pins on the telescopic section
- 8 Telescoping cylinder (piston rod)
- 9 Basic section
- 10 Mechanism



Fixed length, intermediate length, telescoping length

There are lifting capacity tables for main boom fixed lengths, main boom intermediate lengths and main boom telescoping lengths. The lengths are automatically detected by the SLI, and the corresponding lifting capacities according to the *Lifting capacity tables* are released and displayed automatically.

Main boom fixed length

Main boom fixed lengths have the greatest lifting capacities. A main boom fixed length is reached if

- all telescopic sections are locked to a fixed length and
- all telescopic sections are set down.

Main boom intermediate length

A main boom intermediate length is reached if not all telescopic sections are locked to fixed lengths.

Extend the main boom to the required length before hoisting the load.

You cannot telescope the boom with the specified lifting capacities for main boom intermediate lengths.

Main boom telescoping length

The main boom is at a telescoping length if it is extended to an intermediate length and may be telescoped with the current load. The size of the load that can be telescoped depends on the angle of inclination and on the degree of lubrication of the main boom.

41005061

Telescoping

The position of the telescopic sections, i.e. which telescopic section is extended to what extent, is referred to as telescoping.

This section only deals with the displays on the SLI. The telescoping is also displayed on the *ECOS* display; ■■■► p. 12 - 77.

The SLI displays main boom fixed lengths and main boom intermediate / telescoping lengths in different ways.

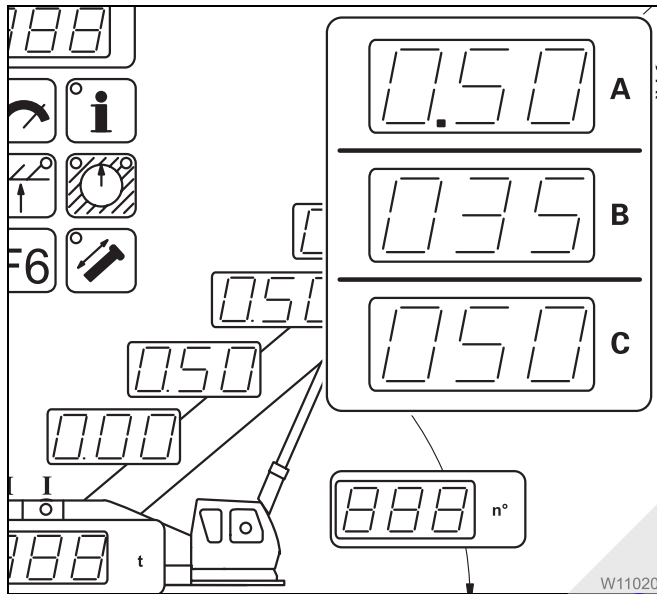

Fixed lengths

Possible fixed lengths are 0%, 50% and 100%.

A The values are indicated with two decimal places, e.g. 0.50 for 50%.

Intermediate lengths

These values are displayed as whole numbers.

B e.g. 035 for 35%

C e.g. 050 for 50% and telescopic section
— unlocked or
— not set down.

Telescoping sequence

The telescopic sections can only be telescoped individually, one after the other.

The telescopic section with the highest number must be **extended** first, then the telescopic section with the next lower number and so on (e.g. V, IV, III, II, I).

The telescopic sections are always **retracted** in the reverse order of extending.



Inspections prior to starting operations

When turning on the ignition, ECOS registers the displayed telescoping status from the current status of the telescoping mechanism and the previously saved locking and unlocking procedures.

Normally ECOS detects differences between the current and the displayed telescoping and indicates the corresponding error message;  *Telescoping mechanism error messages*, p. 15 - 18.

If, in the event of a **malfunction**, values have been deleted, ECOS can no longer calculate the current telescoping and does not issue an error message.



Risk of damage to the telescoping mechanism

Before telescoping the first boom, always check whether the *ECOS* display indicates the current telescoping.

This prevents the telescoping mechanism from being damaged when telescoping.

- Before telescoping the first boom, compare the telescoping indicated on the *ECOS* display with the current telescoping.

You must enter the current telescoping if the current telescoping is not displayed correctly;  *Entering the current telescoping*, p. 15 - 49.

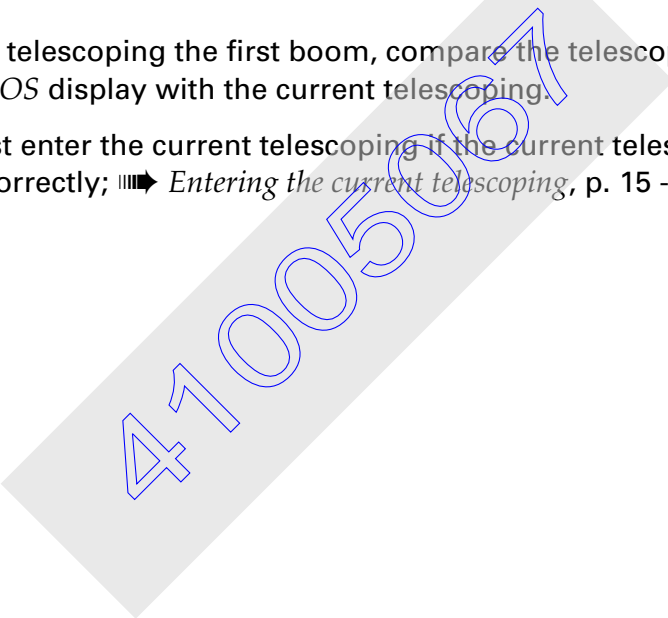
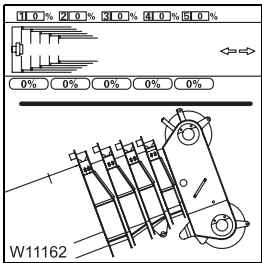

Switching on the telescoping mechanism

All power units are switched off and the lamps in the corresponding buttons light up only dimly after turning on the ignition.

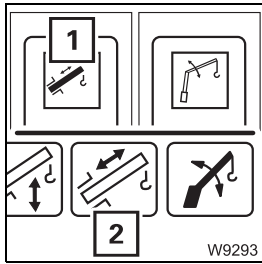

- Press button (1) once.
 - The lamp in button (1) lights up brightly.
 - The symbol 2 is **green** if the telescoping mechanism is switched on.

If the control lever is assigned more than one function, all other power units which are assigned the same control lever operation are switched off;
 ■■■► *Control lever assignment*, p. 10 - 16.



You can have the operating hours of the telescoping mechanism displayed;
 ■■■► p. 12 - 101.

Function of the control lever

This section only describes the function of the control lever. Before telescoping, a number of prerequisites need to be fulfilled as well.

- Before manual telescoping; ■■■► p. 12 - 68.
- Before telescoping with teleautomation; ■■■► p. 12 - 80.

You can adjust the sensitivity of the control levers to the operating conditions; ■■■► *Setting the characteristic curve for the control levers*, p. 12 - 98.



Risk of accidents due to unexpected crane movements

In the case of multiple configuration, check whether the control lever function *Telescoping* is switched on before you move the control lever for telescoping.

This avoids accidents caused by unexpected derricking.



Risk of accidents due to incomplete monitoring

Boom extension is only monitored completely if

- the lifting limit switch is correctly rigged; ■■■► p. 13 - 102
- the lifting limit switch is not overridden, ■■■► p. 12 - 51.



Risk of damage to the hoist rope

The rope can become slack if the hook block touches the ground during retraction operations. Rope loops form, which can cause the load to slip and destroy the hoist rope.



The distance between the hook block and the boom head changes during telescoping. Ensure that the hook block does not trigger the lifting limit switch or touch the ground.

• Additionally carry out the following movements:

- Lower hoist when extending and
- Lift hoist when retracting.

The movements of the lever for telescoping differ depending on the configuration.

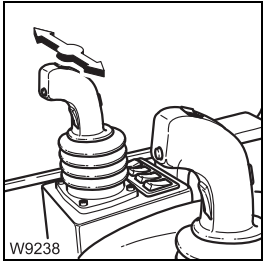

- **With telescopic extension on the right-hand side**

- To extend:**
 - push the control lever to the right.
- To retract:**
 - push the control lever to the left.

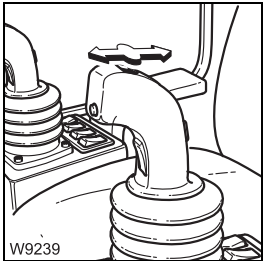

- **With telescopic extension on the left-hand side**

- To extend:**
 - push the control lever forwards.
- To retract:**
 - pull the control lever backwards.

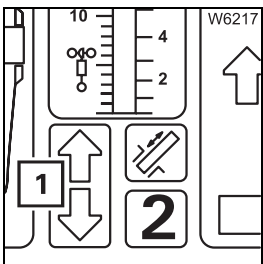

Telescoping starts only if the arrow (1) for the selected telescoping direction is **green**.

If the arrow is red, extension operations are disabled in the indicated direction. This may have different causes, e.g. the telescopic section being in final position, a lifting limit switch shutdown, a malfunction, etc.

You can regulate the speed by moving the control lever and changing the engine speed with the accelerator.



With certain telescoping statuses, the SLI switches telescoping off, e.g. when you leave the telescoping lengths or when the working range limit has been reached;  *SLI shutdown*, p. 12 - 36.

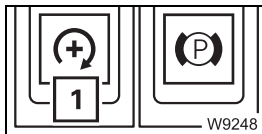

You can set the desired engine speed (idling speed) with the button (1);
 ■■■► p. 11 - 16.

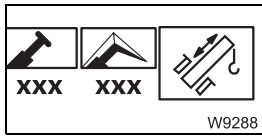

You can limit the maximum telescoping speed in the *Power unit speeds* sub-menu; ■■■► p. 12 - 96.

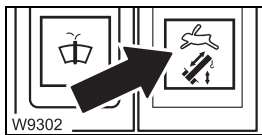

For higher speeds, you can also switch to high-speed mode; ■■■► p. 12 - 86.

Switching off the telescoping mechanism

If the telescoping mechanism is not required, it should be switched off to avoid unintentional use.

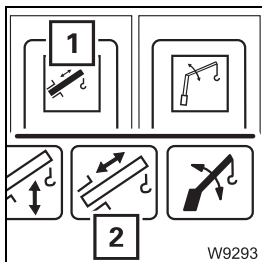

- Press button (1) once.
 - The lamp in the button (1) lights up dimly.
 - The symbol (2) is (red) if the telescoping mechanism is switched off.

In the case of multiple configuration of the control lever, the telescoping mechanism is also switched off if you switch on another power unit which is assigned the same control lever movement; ■■■► *Control lever assignment*, p. 10 - 16.



Manual telescoping

To telescope manually, you must initiate all locking and unlocking processes. The locking and unlocking processes are carried out automatically.

The following sections describe the operating procedures

- Checking the initial position,
- Unlocking the telescoping cylinder; p. 12 - 71
- Moving the telescoping cylinder (without telescopic section); p. 12 - 73
- Locking the telescoping cylinder; p. 12 - 74
- Unlocking the telescopic section; p. 12 - 75
- Telescoping the telescopic section; p. 12 - 77
- Locking the telescopic section; p. 12 - 78



The operating order depends on the current initial position. For an overview of a telescoping process (example); p. 12 - 58.



The lengths given in the following illustrations are purely sample values, and may therefore deviate from the current display.

Checking the initial position

Before telescoping you must check the following statuses:

- **the current telescoping,**
- **the position of the telescoping cylinder,**
- **the position of the locking pins.**

- If necessary, open the main menu and press the button **(1)** once.

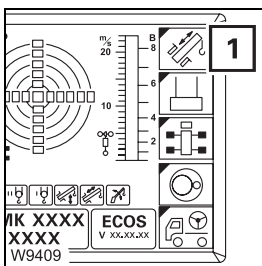

The *Telescoping* submenu opens.

If an error message **(1)** is pending, all operating elements are disabled;

Telescoping mechanism error messages, p. 15 - 18.

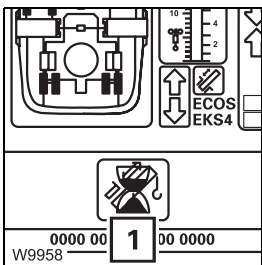

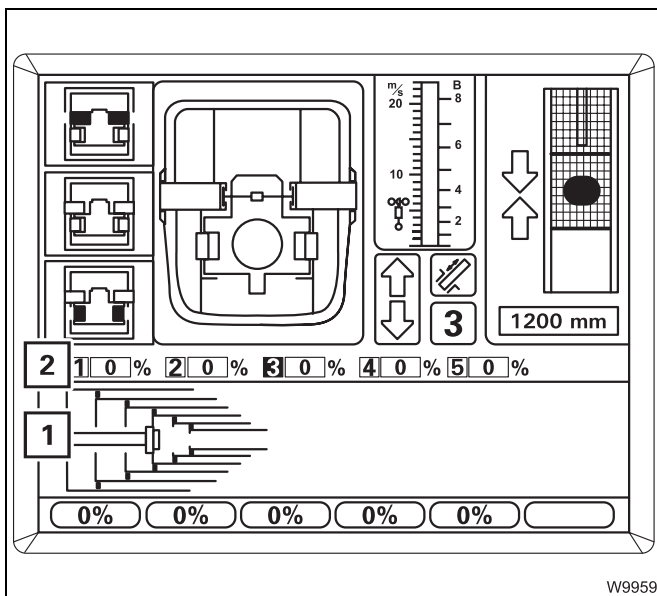

Current telescoping

The display (2) shows the current telescoping in percent for each telescopic section.

The display (1) shows the current telescope diagram.

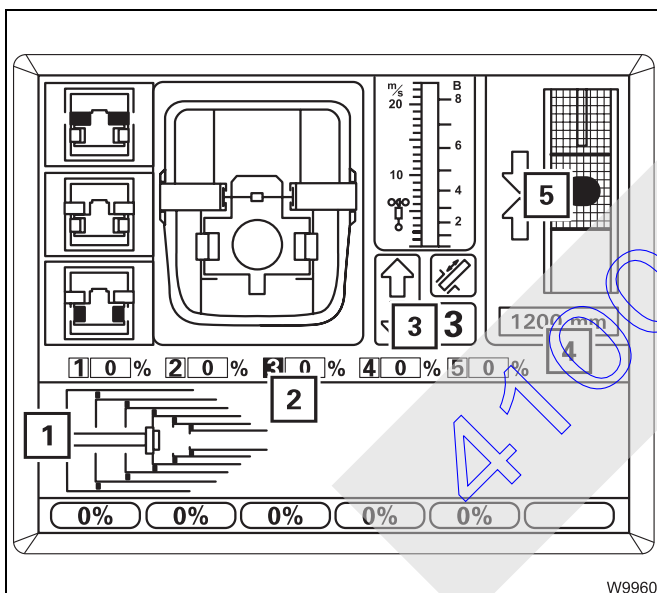

Position of the telescoping cylinder

The display (4) shows how far the telescoping cylinder is extended, e.g. 1,200 mm (3.93 ft).

If the telescoping cylinder is near a locking point

- the display (3) shows the corresponding telescopic section, e.g. telescopic section III.
- the display (2) shows the corresponding telescopic section – number **green**
- the display (5) shows one or two arrows, depending on the distance to the locking point

The display (1) shows a top view of the current position.



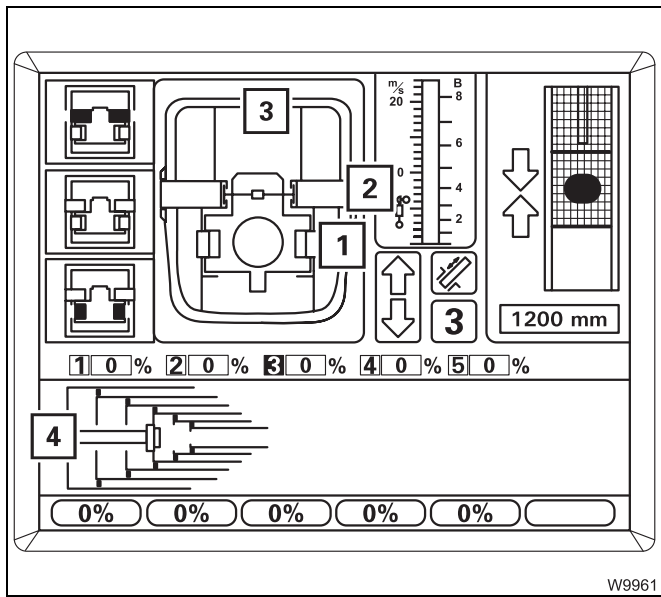

Position of the locking pins

The display (3) shows the current positions of the locking pins

- 1 on the telescoping cylinder and
- 2 on the telescopic section.

The current positions are shown in different colours.

- **Red:** unlocked
- **Green:** locked
- **Yellow:** intermediate position

The display (4) shows the same positions:

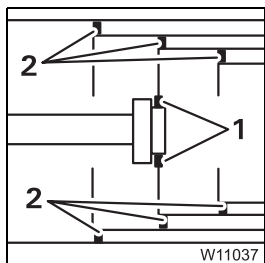

- 1 Locking pins on the telescoping cylinder
- 2 Locking pins on the telescopic sections

The positions are shown as follows:

- **Green:** locked
- **No display:** unlocked or intermediate position

41005067

Unlocking the telescoping cylinder

Unlocking the telescoping cylinder is required for the telescoping cylinder to be operated separately (without telescopic section).

The telescoping cylinder and the telescopic section cannot be unlocked simultaneously.

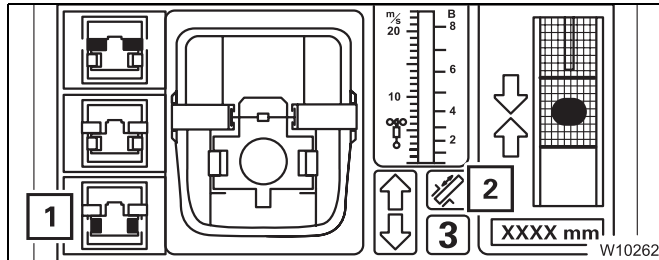

Prerequisites

- Telescoping mechanism on – symbol (2) green
- Telescoping cylinder locked – symbol (1) grey

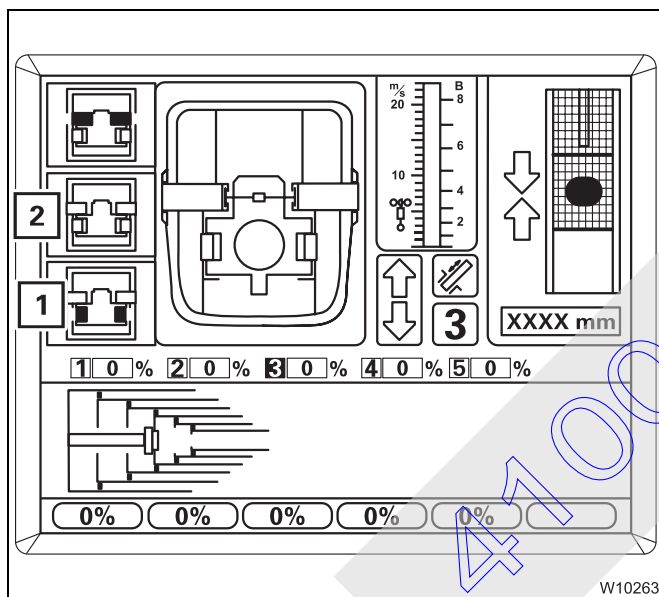

To select Unlock

- Press button (1) once.
- If the telescopic section is locked: symbol (1) flashes – *Unlock telescoping cylinder* is selected.
- If the telescopic section is unlocked: symbol (2) flashes – selected are
 1. *Locking the telescopic section*
 2. *Unlocking the telescoping cylinder*

In the next step, both selections are carried out one directly after the other.

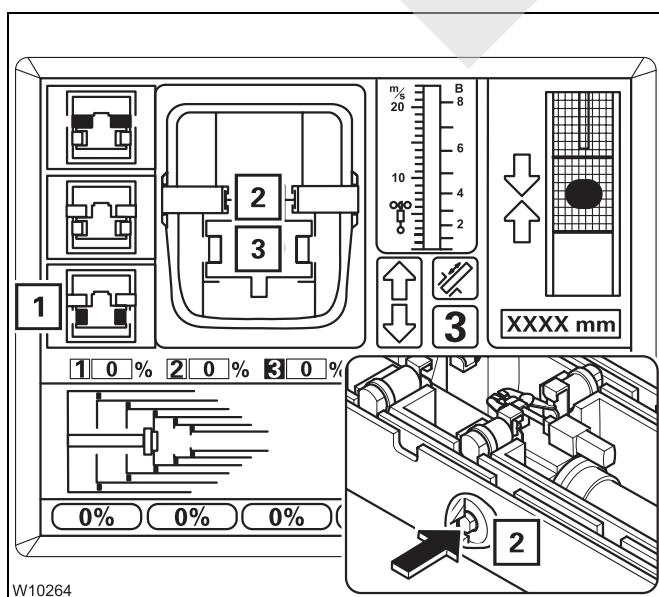

Unlocking the telescoping cylinder

- Move the control lever for telescopic extension.

The locking pins (2) may extend first, as required.

The locking pins(3) retract.

- **Yellow:** intermediate position
- **Red:** unlocked

In the *Unlocked* position the symbol (1) is yellow.

If the control lever is moved, the telescoping cylinder moves immediately.



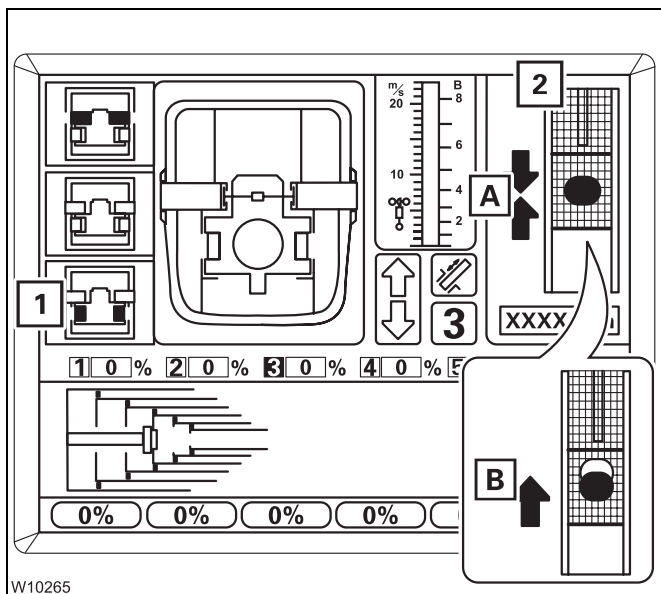

If the symbol (1) is still flashing after approx. 10 seconds, this means that the locking pins are under load.

- Let go of the control lever.

The display (2) shows which movement you need to carry out to take the load off:

- A: retracting
- B: extending



Risk of damage to the boom system

If extending and retracting several times does not cause unlocking, you must not telescope any further towards the stop.

If removing the load does not cause unlocking, you must lock the telescoping cylinder (p. 12 - 74) and start unlocking anew.

41005067

Extending / retracting the telescoping cylinder

Operating the telescoping cylinder (without telescopic section) is required when the telescoping cylinder needs to be moved into a different telescopic section.

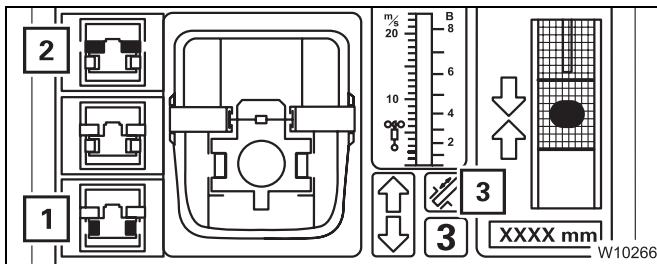

Prerequisites

- Telescoping mechanism on – symbol (3) green
- Telescopic section locked – symbol (2) grey
- Telescoping cylinder unlocked – symbol (1) yellow

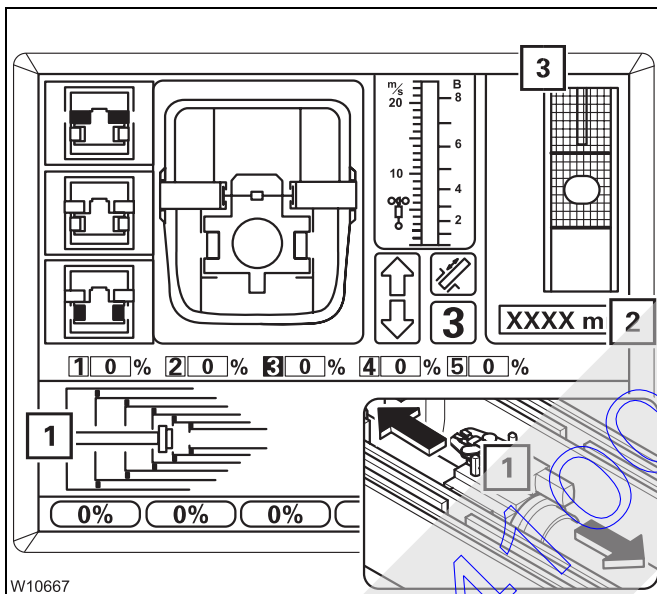

- Extend / Retract
- Move the control lever in the corresponding telescoping direction:
 - To extend: extending
 - To retract: retracting

The telescoping cylinder (1) retracts / extends.

The display (2) shows the currently extended length, e.g. 1,500 mm (4.92 ft).

Near a locking point, the display (3) shows:

- the distance to the locking point
 - A Yellow: approx. 1 m (3.3 ft)
 - B Yellow: smaller than 1 m (3.3 ft)
 - C Green: at the locking point

and

- the direction of travel to the locking point:

- 1 Extending
- 2 Retracting

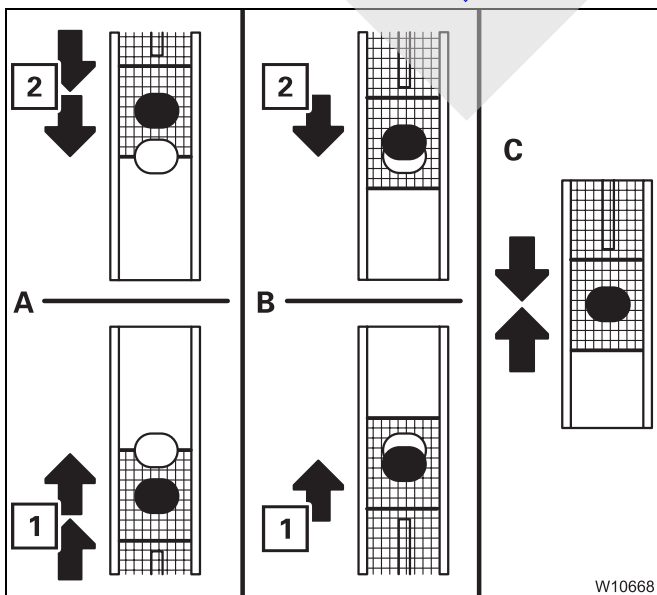

Locking the telescoping cylinder

The telescoping cylinder must be locked to a telescopic section for the telescopic section to be telescoped.

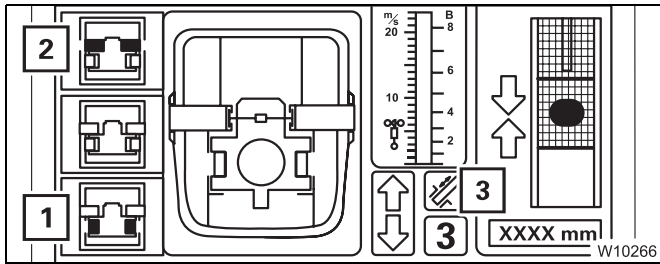

Prerequisites

- Telescoping mechanism on – symbol (3) green
- Telescopic section locked – symbol (2) grey
- Telescoping cylinder unlocked – symbol (1) yellow

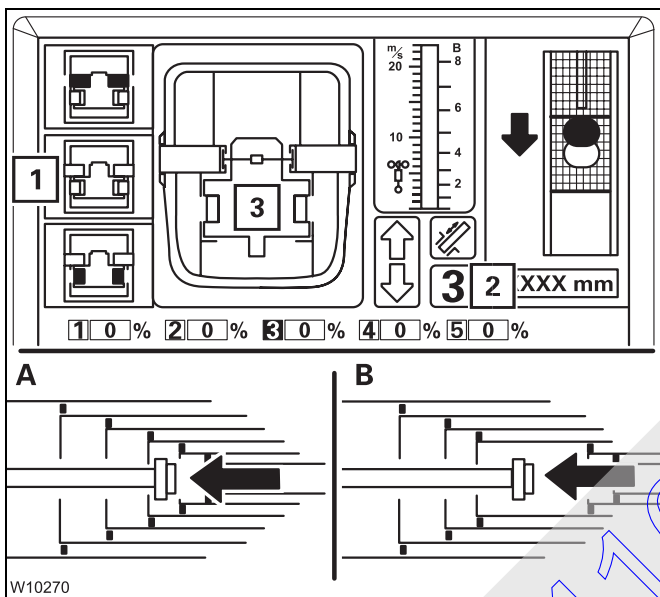

VT to select Lock

- Move the telescoping cylinder to the desired locking point, e.g. to telescopic section III.

Wait until the display (2):

- (A) shows the desired telescopic section or
- (B) shows no telescopic section and the desired locking point is reached next.

- Press button (1) once.
Symbol (1) flashes – Lock telescoping cylinder is selected.

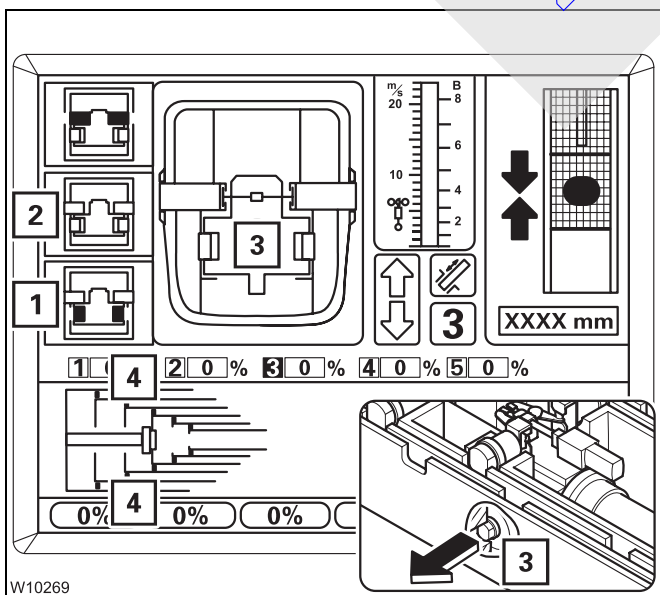

Locking the telescoping cylinder

- Move the control lever until locking is complete.

The locking pins (3) extend at the locking point.

- **Yellow:** intermediate position
- **Green:** locked

In *Locked* position

- the symbol (1) is yellow
- the symbol (2) is grey
- the locking pins (4) are green.

Unlocking the telescopic section

Unlocking a telescopic section is required for the telescopic section to be telescoped.

The telescoping cylinder and the telescopic section cannot be unlocked simultaneously.

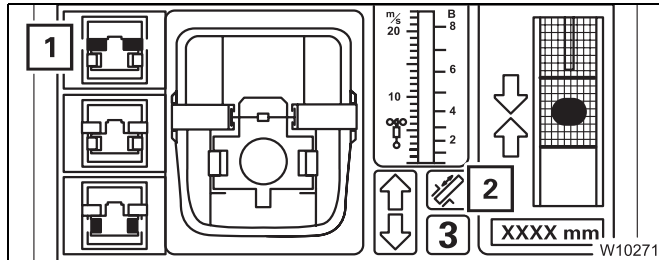

Prerequisites

- Telescoping mechanism on – symbol (2) green
- Telescopic section locked – symbol (1) grey

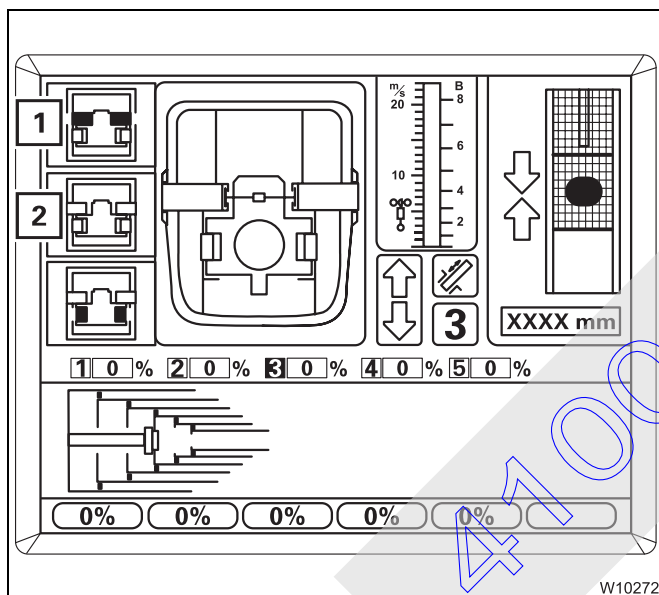

To select Unlock

- Press button (1) once.
- If the telescoping cylinder is locked: symbol (1) flashes – *Unlock telescopic section* is selected.
- If the telescoping cylinder is unlocked: symbol (2) flashes – selected are
 1. *Lock telescoping cylinder*
 2. *Unlock telescopic section*

In the next step, both selections are carried out one directly after the other.

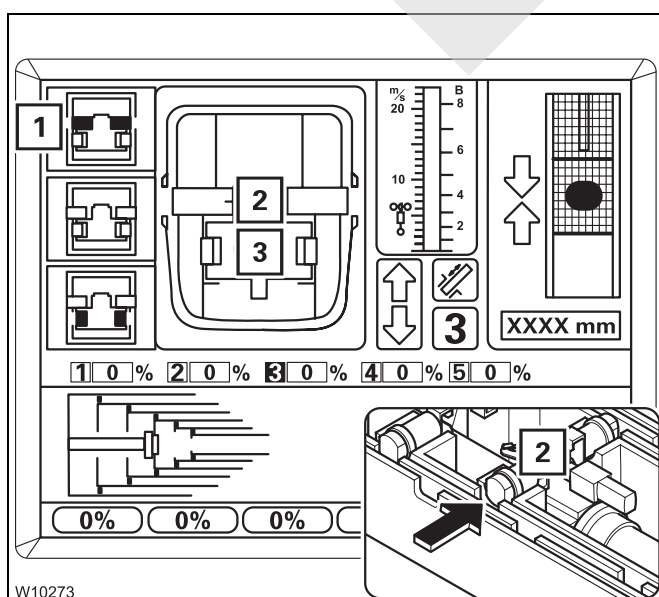

Unlocking the telescopic section

- Move the control lever for telescopic extension.

The locking pins (3) may extend first, as required.

The locking pins(2) retract.

- **Yellow:** intermediate position
- **Red:** unlocked

In the *Unlocked* position the symbol (1) is yellow.

If the control lever is moved, the telescopic section is telescoped immediately.



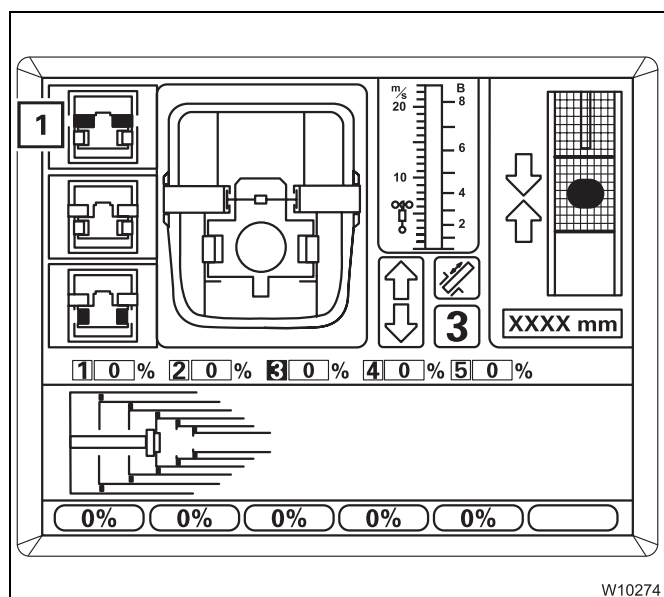

If the symbol (1) is still flashing after approx. 10 seconds, this means that the locking pins are under load.

- Let go of the control lever.

To relieve the load, carefully retract and extend a little bit.



Risk of damage to the boom system

If extending and retracting several times does not cause unlocking, you must not telescope any further towards the stop.

If removing the load does not cause unlocking, you must lock the telescopic section (▶▶ p. 12 - 78) and start unlocking anew.

410050061

Telescoping the telescopic section

You can telescope the telescopic section once it is unlocked.

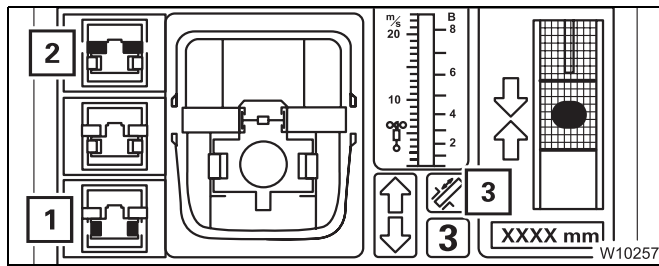

Prerequisites

- Telescoping mechanism on – symbol (3) green
- Telescoping cylinder locked – symbol (1) grey
- Telescopic section unlocked – symbol (2) yellow

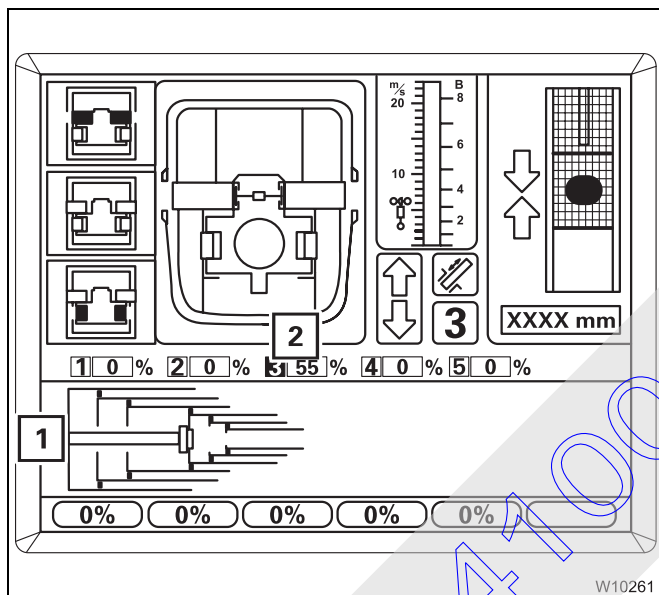

To telescope

- Move the control lever in the desired telescoping direction.

The display (2) shows the currently extended length (telescoping), e.g. 55% for telescopic section III.

The current telescope diagram on the display (1) changes continually.



Locking the telescopic section

Every telescopic section can be locked at fixed lengths – fixed lengths; p. 12 - 62.

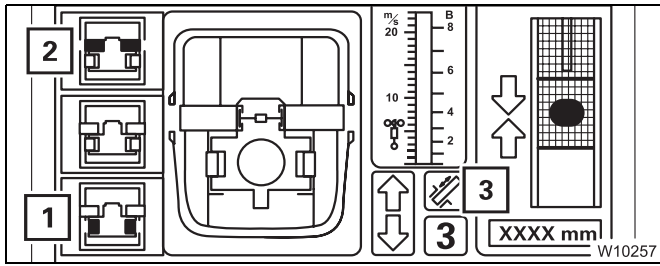

Prerequisites

- Telescoping mechanism on – symbol (3) green
- Telescopic section unlocked – symbol (2) yellow
- Telescoping cylinder locked – symbol (1) grey

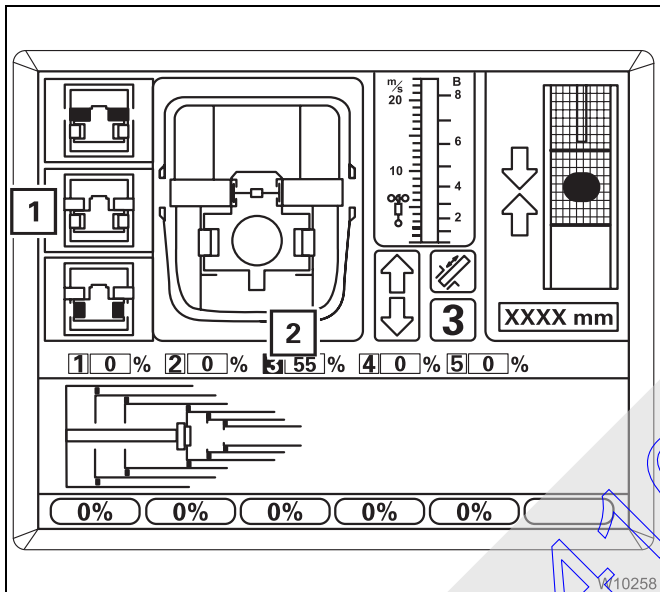

To select Lock

- Telescope to the desired fixed length, e.g. telescopic section III to 100%.

If necessary, wait until the telescopic section moves past a non-desired fixed length by approx. 5%, e.g. at 50% – display (2).

- Press button (1) once.
Symbol (1) flashes – *Lock telescopic section* is selected.

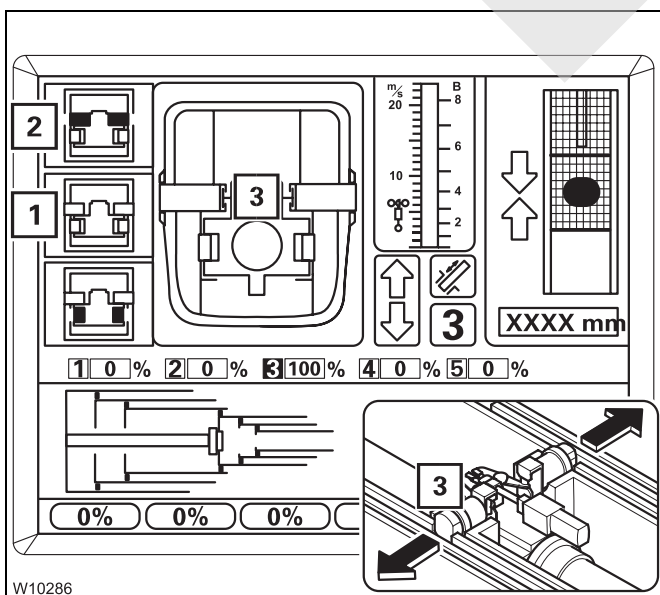

Locking the telescopic section

- Move the control lever until locking is complete.

The locking pins (3) extend at the locking point.

- **Yellow:** intermediate position
- **Green:** locked

The telescopic section is set down;

p. 12 - 60.

In *Locked* position

- the symbol (1) is yellow
- the symbol (2) is grey

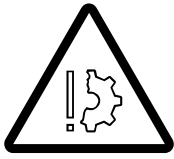

Risk of damage to the telescoping cylinder

Move the control lever until the telescopic section is locked **and set down** – the symbol  needs to be yellow.



In this way you can prevent the load from exerting pressure on the telescoping cylinder and allow the load to be released for fixed lengths.

Locking the telescopic section for on-road driving

Once you have retracted the main boom for on-road driving, you must by all means lock the telescoping cylinder in telescopic section I so that the axle loads are in accordance with the values in the *Driving mode* table;  *Driving modes*, p. 6 - 1.

If telescopic section I was the last telescopic section to be retracted, you can select locking directly.

If another telescopic section was retracted last, you must do the following before selecting locking:

- unlock the telescoping cylinder;  p. 12 - 71
- move the telescoping cylinder into telescopic section I;  p. 12 - 73 and
- lock the telescoping cylinder;  p. 12 - 74.



41005061

Telescopic extension with teleautomation

When telescoping with teleautomation, you enter the desired fixed lengths and then move the control lever in the required direction. Switching between the telescopic sections is carried out automatically by ECOS.



If the desired telescoping is not a fixed length, you can first telescope to the next closest fixed length with the teleautomation and then telescope further to the desired length manually.

- Switch the telescoping mechanism on and open the *Telescoping* submenu; p. 12 - 65.

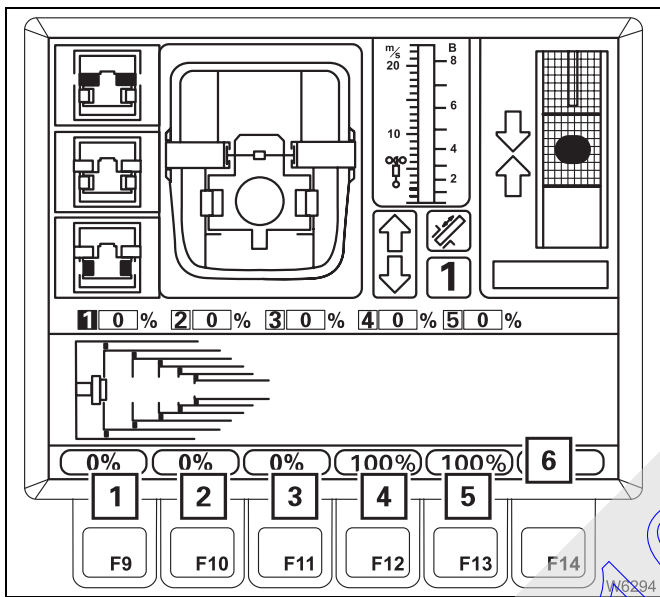

To switch on input mode

The display (6) shows the set values for all telescopic sections.

The values are displayed in **red** if teleautomation is switched off.

No values are shown if the teleautomation is disabled.

- Press one of the buttons (1) to (5).

The values in the display (6) turn **yellow**.

Input mode is now activated.

You can exit the input mode with the button . The values in the display (6) turn **red**.

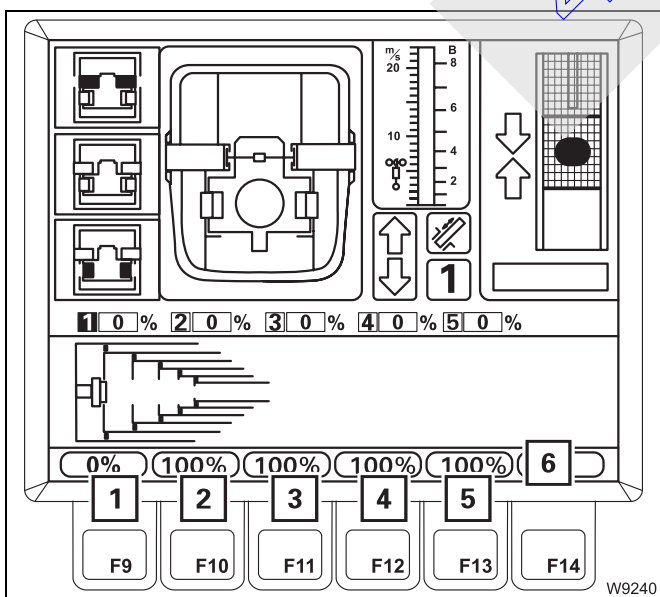

To enter set values

- Press one of the buttons (1) to (5).

Each time you press a button, the corresponding value in the display (6) switches continuously between the fixed lengths.

- Enter the desired set values for all telescopic sections, e.g. 0%, 100%, 100%, 100%, 100%.
- Press the button once.
The entered set values are confirmed.

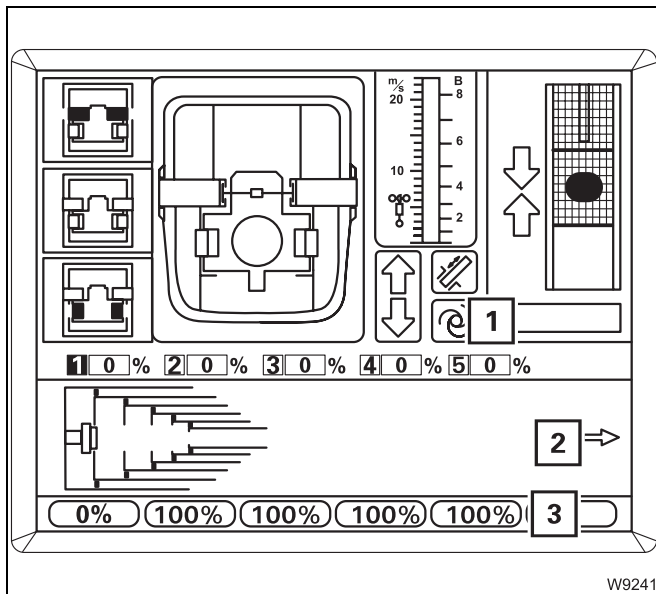

If the set values entered are **not permissible**, the values on the display (3) turn **red**. Tele-automation remains switched off.

If the set values entered are **permissible**, the values on the display (3) turn **green**.

- The symbol (1) is displayed and teleautomation is switched on.
- The display (2) shows the telescoping direction for the teleautomation start, e.g. the arrow pointing to the right, for *Extending*.

To telescope

- Move the control lever for the displayed telescoping direction.
- The arrow (1) for the indicated telescoping direction flashes if you move the control lever in the wrong direction.
- If you move the control lever in the correct direction, ECOS telescopes automatically until the direction has to be changed. Then the arrow (2) for the new telescoping direction is indicated, e.g. for *Retracting*.
- In the case of empty trips of the telescoping cylinder (without telescopic section), both arrows are displayed. Empty trips are automatically performed in both directions, irrespective of the control lever movement.

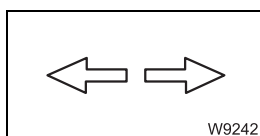
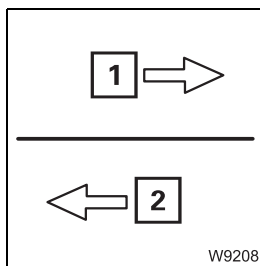

You can regulate the speed for telescoping in the same way as for manual telescoping.



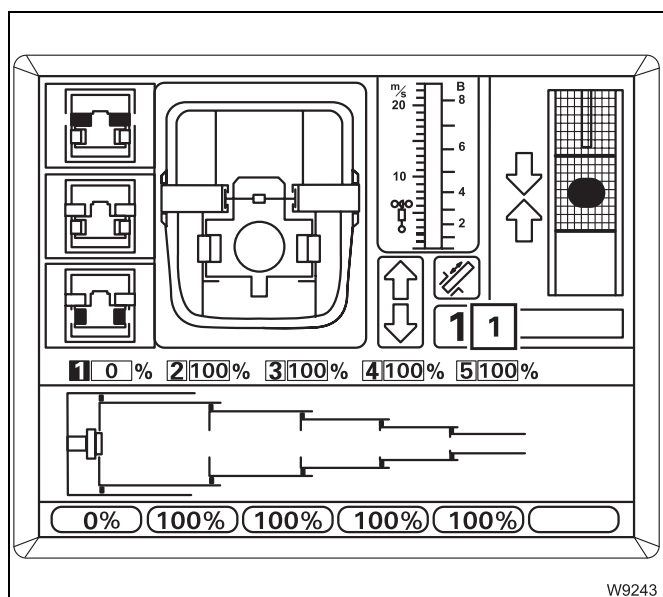

When the entered set values have been reached, the telescoping process will be halted.

- Shift the control lever to the zero position.

The display (1) appears. Teleautomation is switched off.

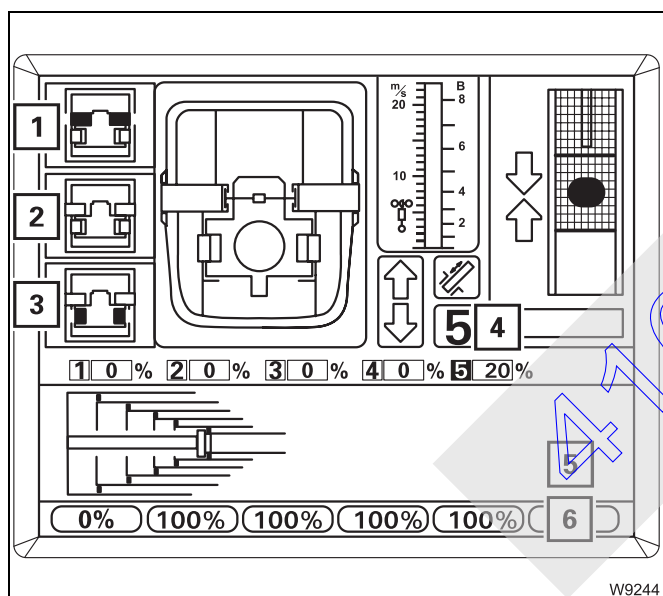

To cancel teleautomation

- Press one of the buttons (1), (2) or (3) once.

The telescoping process is stopped:

- the display (5) goes out.
- the display (4) appears.
- the values in the display (6) are red.

Teleautomation is now switched off.

Example of telescoping with teleautomation

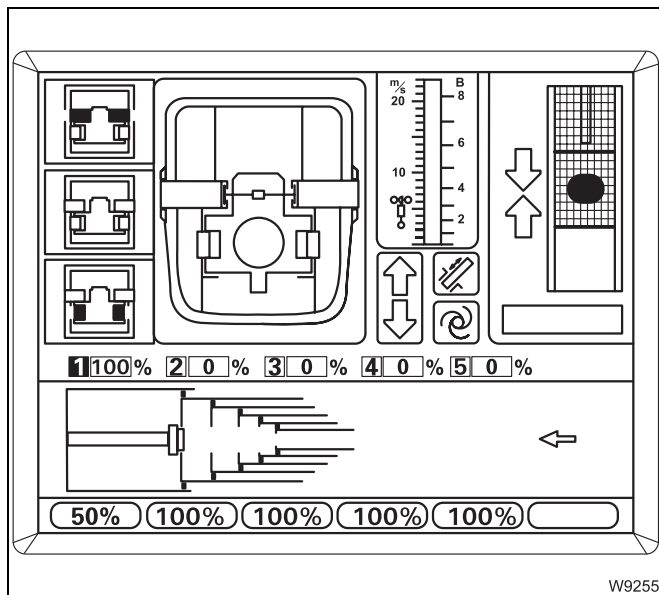

Assuming the current telescoping is 100/0/0/0/0 and the telescoping cylinder is locked in telescopic section I.

The desired telescoping status is 50/100/100/100/100.

The display should correspond to the opposite diagram once you have entered the desired telescoping and confirmed it.

ECOS calculates the following telescoping order:

- Telescopic section I retract to 0%
- Telescopic section V extend to 100%
- Telescopic section IV extend to 100%
- Telescopic section III extend to 100%
- Telescopic section II extend to 100%
- Telescopic section I extend to 50%

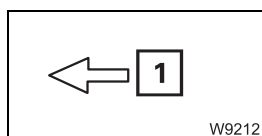

Since the first step is retracting, the arrow (1) points to the left.

- Move the control lever to retract and hold it there.

Telescopic section I will be fully retracted. For this to be done, the following processes are carried out automatically.



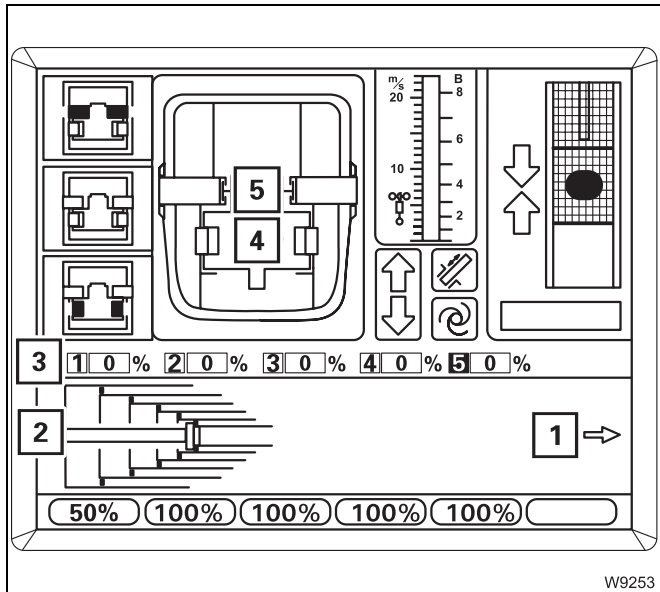

1. Retract telescopic section I – display (3) 0%
2. Lock telescopic section I – pins (5) green
3. Unlock telescoping cylinder – pins (4) red
4. The telescoping cylinder moves into telescopic section V – display (2)
5. Lock telescoping cylinder – pins (4) green

The arrow (1) shows the new telescoping direction – extending.

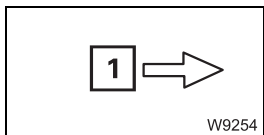

The arrow (1) flashes as long as you are still holding the control lever to retract.

- Move the control lever to extend and hold it there.

ECOS now automatically telescopes telescopic sections V, IV, III and II to the full extent and stops when telescopic section I reaches the set value of 50%.

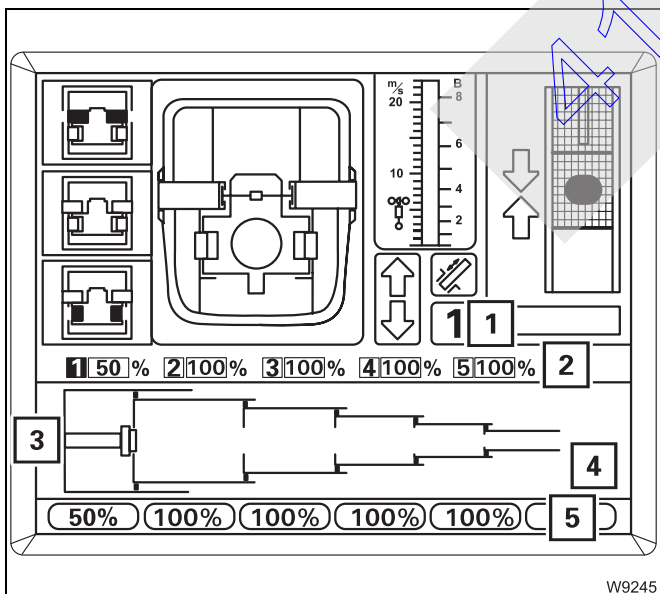

- Shift the control lever to the zero position.
 - The display (4) goes out.
 - The display (1) is active again.
 - The values in the display (5) are **red**.
 - The display (2) shows the current telescoping, e.g. 50 / 100 / 100 / 100 / 100.
 - The display (3) shows the current telescoping procedure.

Teleautomation is switched off.



To extend telescopic section I to 60%, for example, you can now further extend this telescopic section manually.

Telescoping the main boom in horizontal position

- Derrick the main boom to the horizontal position as described in section Lowering the main boom to a horizontal position;  p. 12 - 56.

The SLI automatically switches to the corresponding rigging table. It specifies the maximum permissible telescoping where extending is deactivated (shutdown values  *Lifting capacity table*).

- Set down the load.
- Extend the main boom only until the SLI switches off the extension procedure.



If you continue to extend the main boom after an SLI shutdown, you may enter ranges in which you can neither perform retraction operations nor raise the boom.

41005067

12.3.8

High speed



The slewing gear cannot be operated at high speed.

For higher speeds, you can switch to high-speed mode.



Risk of accidents due to the sudden acceleration of operations

Reduce the engine speed before starting high-speed mode.

This prevents the movements from becoming excessively accelerated, which may result in the truck crane starting to sway and overturning.

Switch on function

The function *High speed* is only enabled when the carrier ignition is switched off.

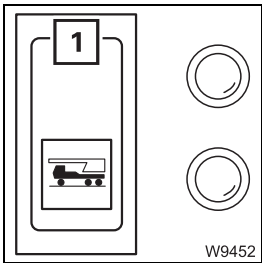

- Turn off the carrier ignition, if necessary. Press the button (1) up once. The lamp in the button must have gone off.

Derricking gear / Telescoping mechanism

High-speed mode is always switched on and off for the derricking gear and the telescoping mechanism simultaneously.

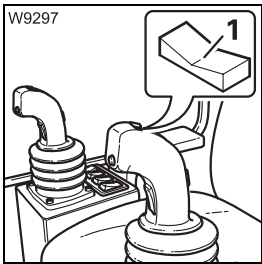

To switch on briefly

- Press the button (1) down on the right – inwards. High-speed mode is active until you let go of the button.

Continuous operation

- Press the button (1) down on the left – outward. High-speed mode is active until you press the button again.

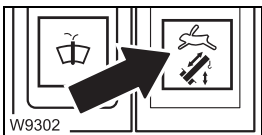

The lamp (1) indicates the current status:

- On:** high-speed mode switched on
Off: high-speed mode switched off



When lowering the boom, only the start of the derricking procedure from steep boom positions is performed in high-speed mode. The derricking speed is not increased in high-speed mode. High-speed mode is disabled for raising when performing operations with the lattice extension.

Hoists

The main hoist and auxiliary hoist are always switched simultaneously to high-speed mode.

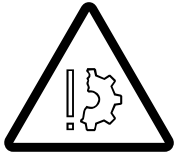

Risk of accidents due to overloading

Make sure the lifted load is no more than 50% of the maximum load according to the *Lifting capacity table* (maximum degree of utilisation of 50%) before operating the hoists in high-speed mode.



Danger of slack rope formation with a light hook block

If you switch on high-speed mode at high speeds, a light hook block will not be able to keep the hoist rope taut if it is hoisted up high with a small number of reevings and a large boom length.



Danger of slack rope formation with large number of reevings

If you switch on high-speed mode with a large number of reevings and without a load, slack rope may form because the hook block is lowered too slowly due to the high degree of friction.

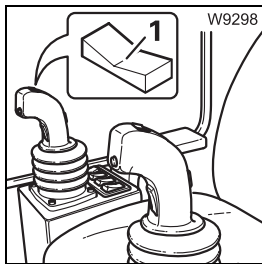

To switch on briefly

- Press the button (1) down on the left – inwards.
High-speed mode is active until you let go of the button.

Continuous operation

- Press the button (1) down on the right – outward.
High-speed mode is active until you press the button again.

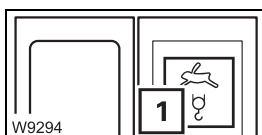

The lamp (1) indicates the current status:

- On:** high-speed mode switched on
- Off:** high-speed mode switched off



The speed of the hoists will only be significantly increased by switching to high-speed mode if you have extended the control lever by more than 70%.

12.3.9

Slewing gear



Danger of overturning when slewing with a rigged counterweight

Always check before slewing whether slewing is permitted in the truck crane's current rigging mode (counterweight, outrigger span, working radius).

Correct the rigging mode if necessary; *Slewing with rigged counterweight*, p. 13 - 82.



You can have the operating hours of the slewing gear displayed; p. 12 - 101.

Switching on the slewing gear

All power units are switched off and the lamps in the corresponding buttons light up only dimly after turning on the ignition.

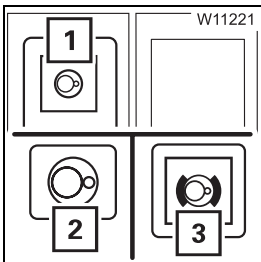

- Press button (1) once.
 - The lamp in button (1) lights up brightly.
 - The symbol 2 is **green** if the slewing gear is switched on.
 - The slewing gear brake is released – lamp (3) goes out.



If an SLI code has been entered for the working position 0° to the rear or *Free-on-wheels*, an SLI shutdown will occur after switching on the slewing gear, and slewing will be disabled. To acknowledge the shutdown you must either switch off the slewing gear or set down the load and enter an SLI code for the 360° working range.

Slewing

The following prerequisites must be fulfilled before slewing:

- Houselock is switched off; p. 12 - 14.
- The counterweight lifting cylinders are fully retracted.
- Slewing is permissible with the current rigging mode; p. 13 - 82.
- The current rigging mode is entered on the SLI.

If slewing is not permissible with the current rigging mode, the slewing gear is disabled.



Danger of overturning when slewing with an incorrectly set SLI

Therefore always check before slewing whether the SLI code valid for the current rigging mode is displayed.

This prevents slewing operations from being released within impermissible ranges, which would cause the truck crane to overturn.



Risk of crushing during slewing

Before slewing, actuate the horn and ensure there are no persons in the slewing range.

In this way you prevent persons from becoming crushed between the superstructure and the carrier or between the superstructure and other parts.



Risk of the main boom buckling

Do not accelerate the slewing speed to such a degree that the load starts to swing.

You can adjust the sensitivity of the control levers to the operating conditions; *Setting the characteristic curve for the control levers*, p. 12 - 98.



The slewing movement is not automatically braked. If you let go of the control lever or move it to zero position, the slewing movement will slowly run down; *Braking the slewing movement*, p. 12 - 91.

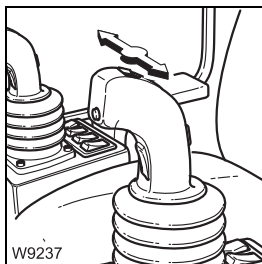

- To slew to the left:** • push the control lever to the left.
To slew to the right: • push the control lever to the right.

You can regulate the speed by moving the control lever and changing the engine speed with the accelerator.



The maximum slewing speed is automatically reduced as the working radius is increased. If you now reduce the working radius (e.g. by retracting the boom), the slewing speed is automatically increased again.

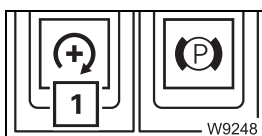

You can set the desired engine speed (idling speed) with the button (1); p. 11 - 16.

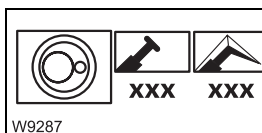

You can limit the maximum slewing speed; p. 12 - 96.





Viewing the slewing angle

In the submenu *Slewing gear / houselock* – the display (1) indicates the current position.

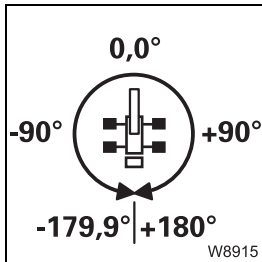

0° means that the superstructure is slewed to the rear.

- Angles in the **right-hand semi-circle** are displayed as **positive** values (0° to +180.0°).
- Angles in the **left-hand semi-circle** are displayed as **negative** values (0° to -179.9°).

Slewing to 0° or 180°

You can automatically stop the slewing movement at the slewing angles 0° and 180°, e.g. in order to set down the main boom.

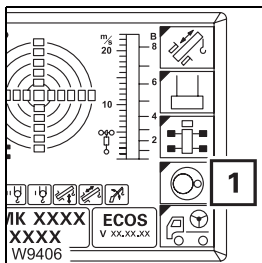

- If necessary, open the main menu and press the button (1) once.

The *Slewing gear / houselock* submenu opens.

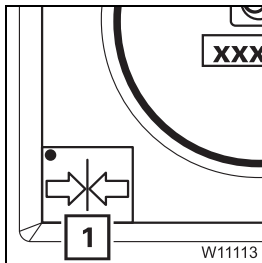

After switching on the ignition, the *Stop at 0° / 180°* function is switched off.

- Press the button (1) once – dot **green**.
Function *Stop at 0° / 180°* is switched on.

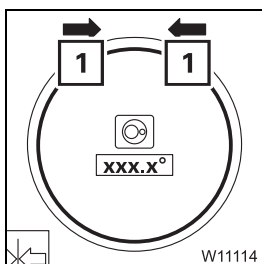

- Slew to slewing angle 0° or 180°.

When the slewing angle of 0° or 180° has been reached:

- the slewing movement is stopped automatically,
- the slewing gear brake is engaged,
- both arrows (1) are shown.

If you have stopped too late, an arrow (1) indicates in which direction you need to slew in order to reach the slewing angle.

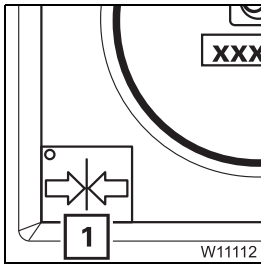

Slewing is blocked until you switch off the *Stop at 0° / 180°* function.

- Press the button (1) once – dot **black**.
Function *Stop at 0° / 180°* is switched off.

Braking the slewing movement



You may only brake the slewing movement with the Slewing gear brake.

Risk of the main boom buckling

Do not under any circumstances switch off the slewing gear to brake it. Only switch off the slewing gear after the superstructure has stopped turning.

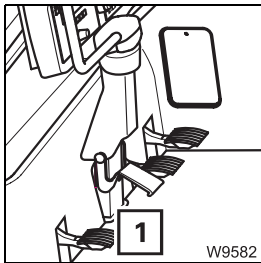

- Actuate the slewing gear brake (1). Do not brake to such a degree that the load starts to swing.

If you only move the control lever to zero position, the slewing movement will slowly run down.

Slewing gear free-wheel

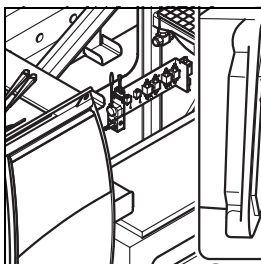

The slewing gear free-wheel is required if the slewing gear needs to be slewed by means of external forces, e.g. when operating with two cranes.

- Switch on the slewing gear.
The slewing gear brake is released – lamp (1) lights up.
- Shift the control lever (2) to zero position.



Switching off the slewing gear

If the slewing gear is not required, it should be switched off to avoid unintentional use.

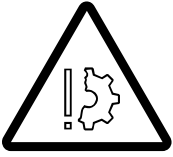

Risk of damage to the main boom

Brake the slewing movement down to a standstill before you switch off the slewing gear. The slewing gear brake is automatically engaged when the slewing gear is switched off.

In this way you can prevent lateral forces taking effect on the main boom due to long delays or swinging loads.

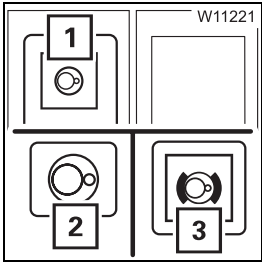

- Press button (1) once.
 - The lamp in the button (1) lights up dimly.
 - The symbol (2) is (red) if the slewing gear is switched off.
 - The slewing gear brake is engaged – lamp (3) lights up.

12.3.10

Possible movement combinations

- The main hoist, telescoping mechanism, derricking gear and slewing gear can be operated in almost any combination simultaneously. Restrictions are specified for the respective power units.
The telescoping mechanism and derricking gear can only be operated simultaneously when the control lever assignment is from *Version 1*;
▶▶▶ p. 10 - 16.
- The auxiliary power units – Tilt crane cab, Counterweight lifting unit – cannot be operated with the *Extending* movement.
Moving the auxiliary power units in combination with other power units can result in reductions of speed.
- Lattice extension derricking gear
The lattice extension derricking gear cannot be operated in combination with the *Extending* movement.





Certain movement combinations can reduce the speed in high-speed mode.

12.3.11 Hydraulic oil cooling

Depending on the truck crane version, there are one or two hydraulic oil coolers that regulate the hydraulic oil temperature automatically.

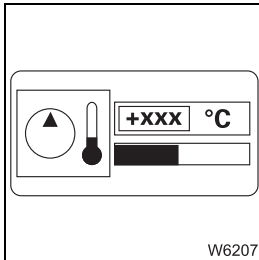
- In addition to this, you should ensure that the maximum permissible hydraulic oil temperature of 80° (176 °F) is not exceeded.



The current hydraulic oil temperature is displayed in the *Monitoring*  sub-menu. If the maximum permissible temperature has been reached, the bar below the display turns **red**. A warning message is issued additionally;  *Warning submenu*, p. 12 - 102.

When the hydraulic oil temperature reaches 80 °C (176 °F):

- Stop crane operation.
- Let the hydraulic oil cool down while the engine is running.

41005067

Blank page

41005067

12.4

Settings and displays for crane operation

This section only describes settings and displays needed during crane operation. Operating elements that can be assigned to other procedures are described with the corresponding procedures.

12.4.1

Inclining the crane cab

With the relevant equipment, you can incline the crane cab to the rear in order to attain a better sitting position when working at great heights.



Risk of accidents due to objects overturning in the crane cab

Close the crane cab door before inclining and remove all loose objects (e.g. bottles) from the crane cab.

In this way you prevent objects from tipping over, the crane cab door opening by itself, and unintended operational accidents caused by fright.

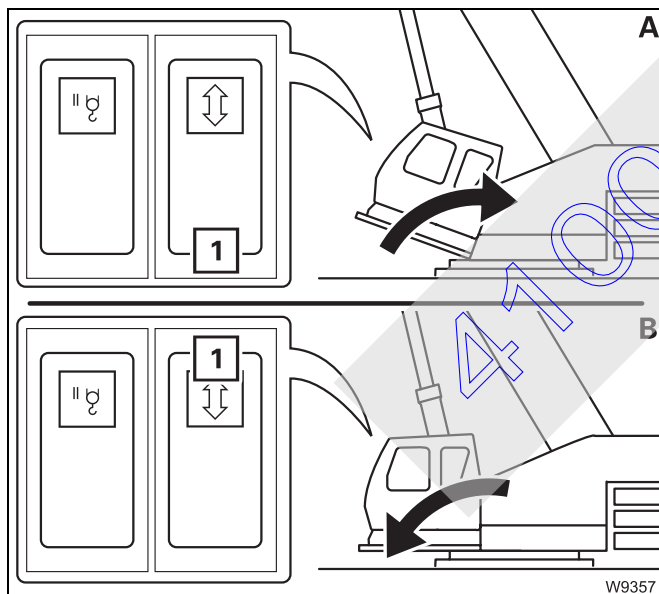

(A) – To incline to the rear

- Close the crane cab door.
- Press the button (1) down.

(B) – To incline to the front

- Close the crane cab door.
- Press the button (1) up.

The crane cab is inclined as long as you hold the button down or the end position is reached.

12.4.2

Setting the idling speed

▣▣▣▣ *Setting the idling speed, p. 11 - 16.*

12.4.3

Adjusting the stroke interval of the windscreen wiper

You can set a value between 3 and 30 seconds for the front and roof window wiper stroke interval.



The higher the selected value is, the longer the pauses between the strokes of the wiper are.

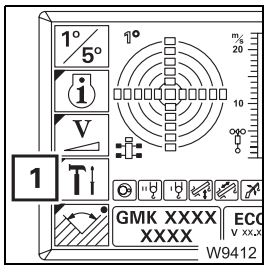

- If necessary, open the main menu  and press the button (1) once. The *Settings* submenu opens.

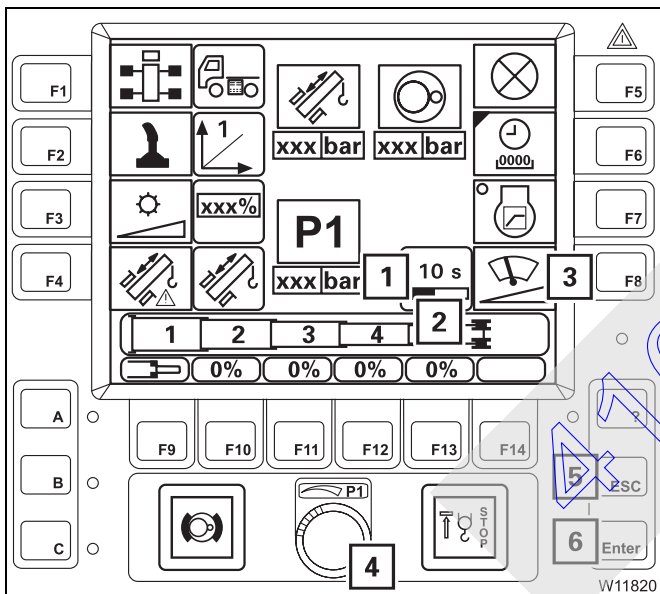

The display (1) shows the current value.

- Press button (3) once. Bar (2) red + input on.
- To cancel the input – press button (5) once.
- Change the value using the switch (4).
- Confirm the changed value – press button (6) once.

12.4.4

Limiting the power unit speeds

You can enter how many percent of the maximum speed shall be enabled for each power unit.

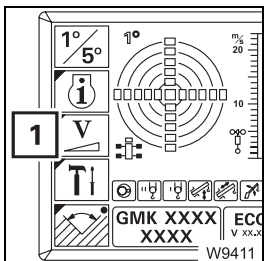

- If necessary, open the main menu  and press the button (1) once. The *Power unit speeds* submenu opens.

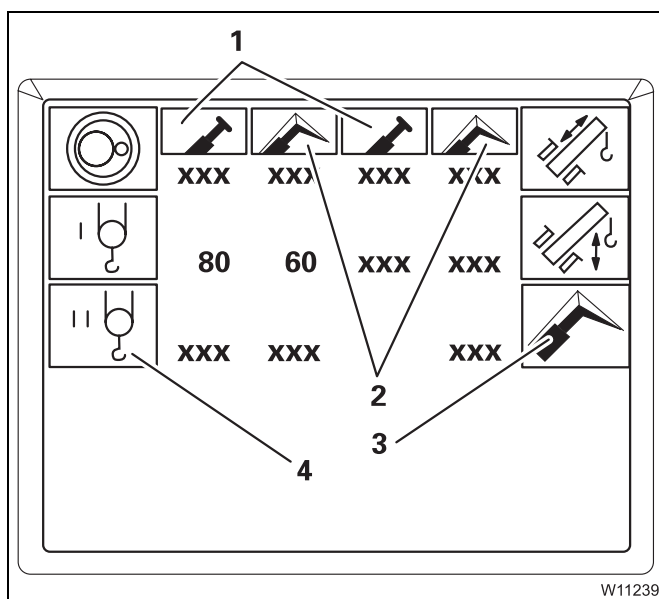

The symbols (1) or (2) for the current operation are **green**.

- 1 Main boom operation
- 2 Lattice extension operation – button (3) active

The values below the green symbols are used, e.g. 80% for the main hoist in main boom operation.

The values for the slewing gear and derricking gear only apply if they are lower than the automatically limited values. The automatically limited values are not displayed.

The button (4) is only active if the auxiliary hoist is connected.

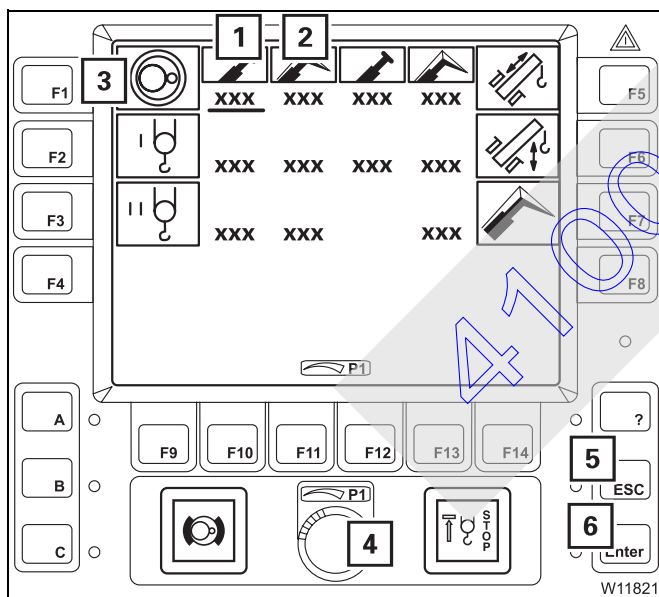

Changing values

- Repeatedly press, for example, the button (3) for the slewing gear until the bar under the desired value is at (1) or (2) – input on.
- To cancel the input – press button (5) once.
- Change the value using the switch (4).
- If necessary, change the values for other power units in the same way.
- Confirm the changed values – press button (6) once. All changed values are applied.

12.4.5

Setting the characteristic curve for the control levers

The control lever characteristic curve determines how high the power unit speed should be for a particular control lever movement.

The set control lever characteristic curve always applies to both control levers and to all power units operated with the control levers.

- If necessary, open the main menu  and press the button **(1)** once. The *Settings* submenu opens.

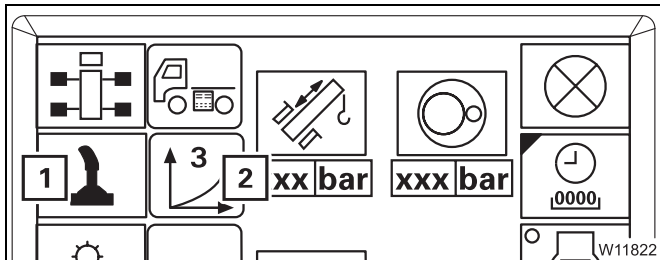
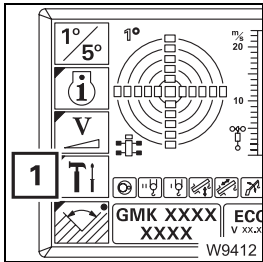

The set characteristic curve is shown on the display **(2)**.

- Repeatedly press the button **(1)** until the desired characteristic curve is displayed, e.g. characteristic curve **(3)**.

There are five characteristic curves:

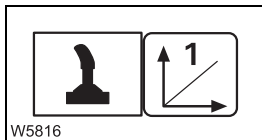

Linear characteristic curve (1)

The movement of the control levers effects a uniform speed increase. Even small movements of the control lever will produce a high speed.

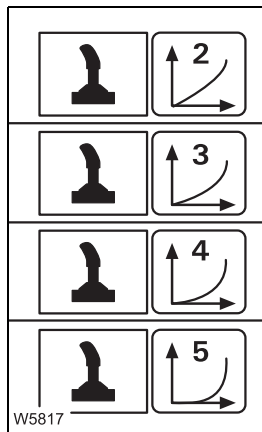

Progressive characteristic curves (2) to (5)

The speed is kept lower in the front range of the movement than with characteristic curve **(1)** and increases only with larger movements.

The higher the number of the characteristic curve, the further the control lever must be moved to instigate a clear increase in speed.

With characteristic curve **(5)**, you work particularly sensitively with the control lever.

12.4.6 Critical load control

Function

The critical load control prevents the engine from stalling at low engine speeds.

ECOS registers the currently available motor output and the hydraulic performance instantaneously required by the power units.

If the required hydraulic performance is above the current motor output (e.g. when connecting an additional crane movement), the critical load control automatically reduces the hydraulic performance of the power units. In this, the control lever movement is taken into account so that the power unit speeds remain equal.

The slewing gear is not influenced by the critical load control.

Switching on and off

The critical load control is switched on together with the ignition.

You should only switch off the critical load control if it is faulty (engine stalls or individual power units can no longer be controlled).

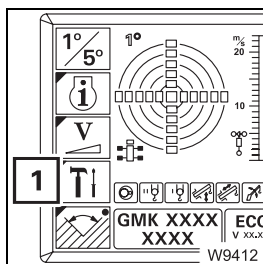

- If necessary, open the main menu (Esc) and press the button (1) once.

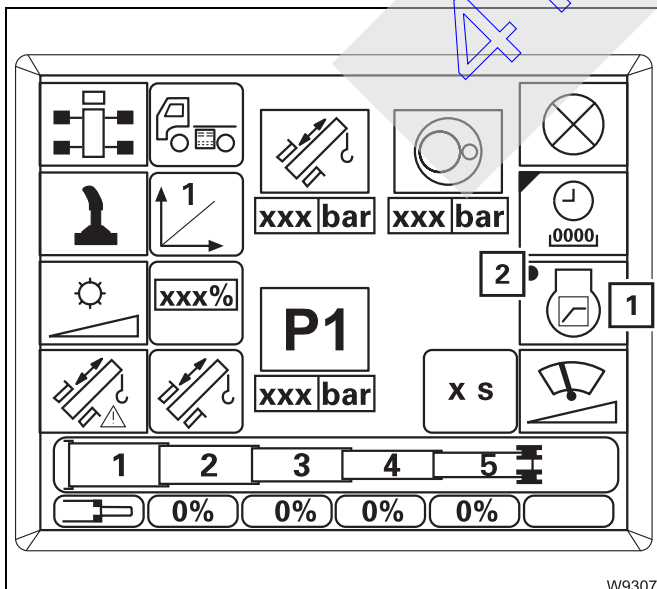

The *Settings* submenu opens.

To switch off the critical load control

- Press the button (1) repeatedly until dot (2) is **black**.

To switch on the critical load control

- Press the button (1) repeatedly until dot (2) is **green**.

12.4.7

Operation of the directional spotlights

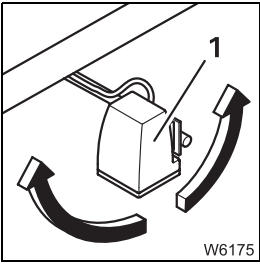

With the relevant equipment, the directional spotlights (1) are located on the main boom. Operation is carried out from the crane cab.



Risk of accidents due to being blinded when driving on the road

When driving on the road, always direct the spotlight in such a way that the reflector points downwards. In this way you can prevent yourself or other motorists and cyclists from being blinded and causing accidents.

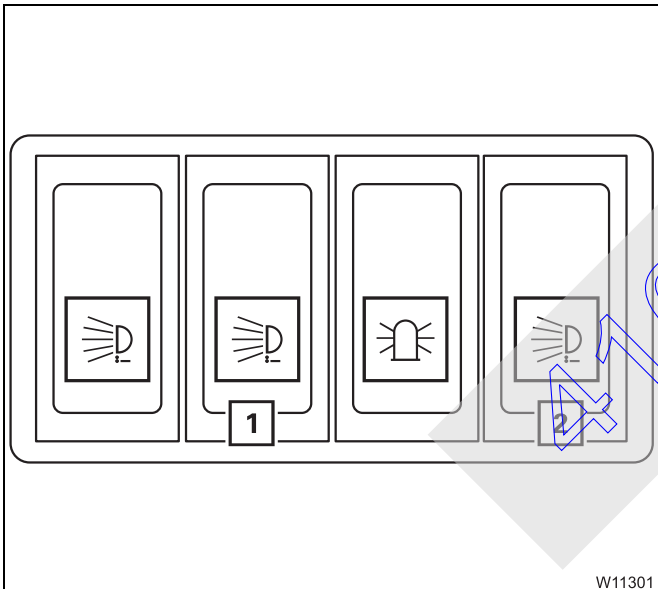

Switching on

- Press switch (1) down.

Switching off

- Press switch (1) up.

To direct the spotlights forwards

- Press button (2) up.

To direct the spotlights backwards

- Press button (2) down.

The direction of the spotlights is adjusted until you let go of the button or they reach their end position.

12.4.8 Displaying the operating hours

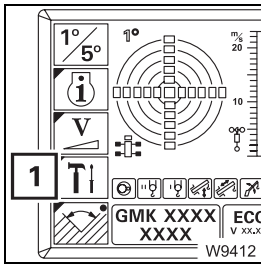

If necessary, open the main menu  and press the button (1) once.

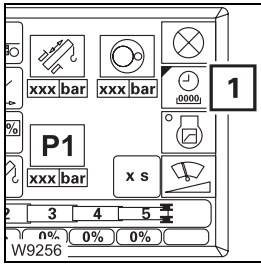

The *Settings* submenu opens.

- Press button (1) once.

The *Operating hours* submenu opens.

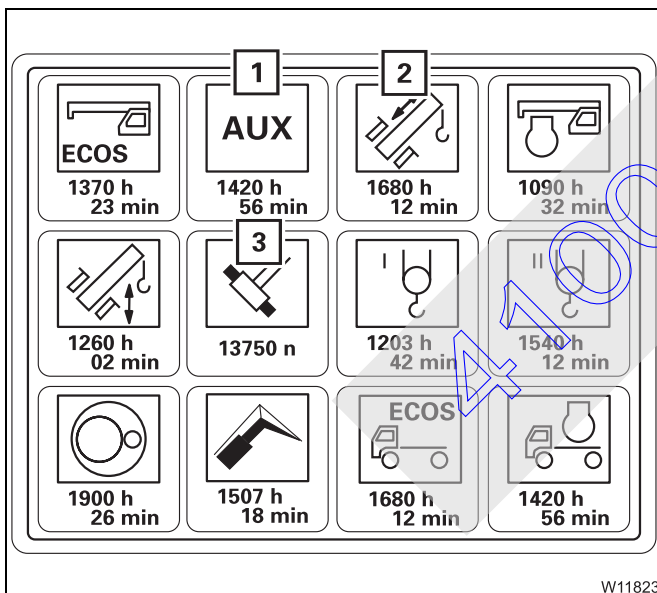

The operating hours are displayed below the symbols, e.g. 1,680 hours and 12 minutes for the telescoping mechanism (2).

Exception: the value below the symbol (3) indicates how often the cycle *Unlock telescopic section* has been operated, e.g. 13,750 times.

Auxiliary power units (1) include:

- counterweight hoist unit,
- crane cab inclination.

W11823

12.4.9

Warning submenu

ECOS differentiates between warning messages and error messages (error messages  p. 12 - 106). A warning message indicates that certain values do not correspond to a set value.

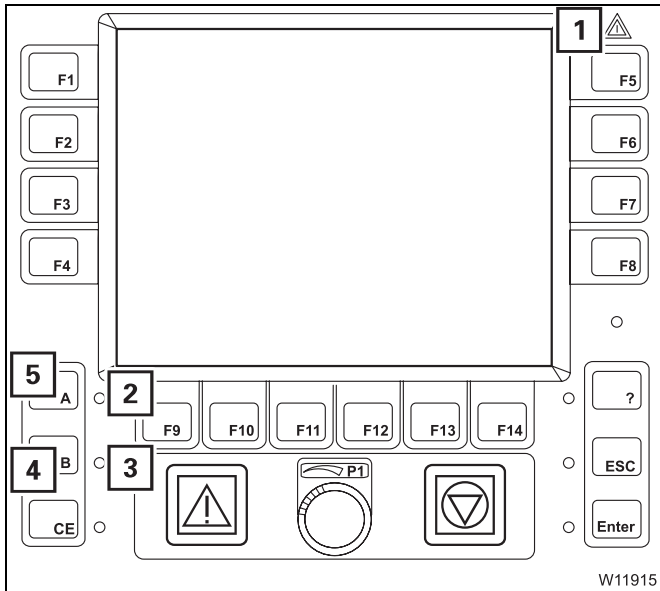

In the event of a warning message:

- the lamp (1) and
- the lamp (2) for *Superstructure* warning or
- the lamp (3) for *Carrier* warning will flash.

For more information

- Press button (4) or (5) next to the flashing lamp once – the corresponding *Warning* submenu will be opened.

The warning message is acknowledged – lamp (2) or (3) lights up (does not flash any longer).

Meaning of the symbols

The colour of the symbols indicates whether a warning message is active in the corresponding area:

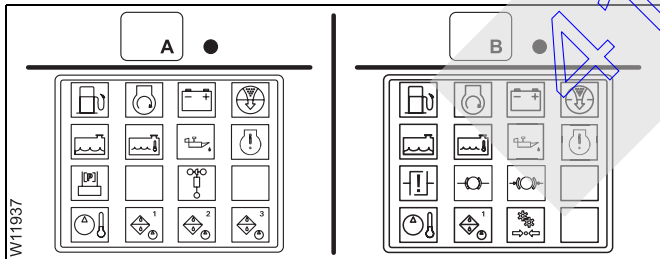

- Symbol **grey** – no warning message.
- Symbol **red** – warning message.

Make the following inspections if a symbol is displayed in **red**.



This section deals with the symbols in the *Superstructure* and *Carrier* warning submenus. Symbols which are present in both submenus are only explained once. Follow the cross-references for continued procedures in part 1 or part 2, depending on the submenu opened.



Risk of damage if warning messages are not observed

Observe the following information in good time and take the appropriate remedial measures if a warning message appears. In this way, you can prevent these malfunctions from causing malfunctions on the truck crane.

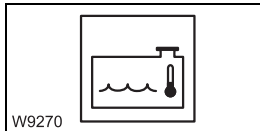

Coolant too hot

The coolant in the engine is hotter than approx. 95 °C (205 °F).
Display of the current temperature; ■■■▶ p. 11 - 15, ■■■▶ p. 4 - 17.
Possible cause and remedy; ■■■▶ p. 15 - 22, ■■■▶ p. 7 - 28.

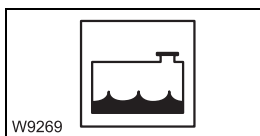

Coolant level too low

- Immediately top up the coolant so that the engine does not overheat; ■■■▶ *Maintenance manual*.



Oil pressure too low

At the same time a warning buzzer sounds.

- Set down the load as soon as possible and turn off the engine.
- Check the oil level; ■■■▶ *Maintenance manual*
- Correct the oil level if necessary. If the error message is still displayed, please contact **CraneCARE**.



Risk of damage to the engine if the oil pressure drops

Turn the engine off as soon as possible and look for the cause if the lamp goes on or the warning buzzer sounds.

Never restart the engine before you have found the cause and eliminated the problem. ■■■▶ p. 15 - 13, ■■■▶ p. 7 - 23

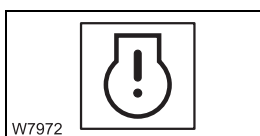

Engine electronics

Malfunction in the engine electronics; ■■■▶ p. 15 - 13, ■■■▶ p. 7 - 23.

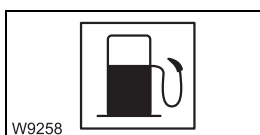

Refuelling

The fuel tank is only filled up to a level of approx. 5%.

- Refuel before the fuel is used up; ■■■▶ p. 11 - 5, ■■■▶ p. 4 - 7.

When the fuel tank is almost empty, air is sucked in and you must bleed the fuel system; ■■■▶ *Maintenance manual*.



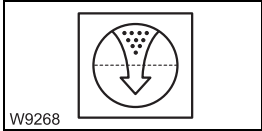

Replacing the air filter

- Replace the air filter as soon as possible; *Maintenance manual*.

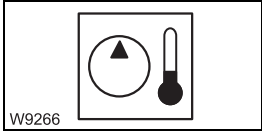

Hydraulic oil too hot

The hydraulic oil is hotter than 80 °C (176 °F).

Display of the current temperature; p. 11 - 15, p. 4 - 18.

Possible cause and remedy; p. 15 - 22, p. 7 - 28.



Danger of overheating

There is a fault if the hydraulic oil temperature exceeds 80 °C (176 °F).

Set down the load as soon as possible and try to find the cause.

Set down the load as soon as possible and turn off the engine if the temperature of the hydraulic oil exceeds 100 °C (176 °F).



Replacing the hydraulic oil filter

- Replace the corresponding hydraulic oil filter as soon as possible; *Maintenance manual*.

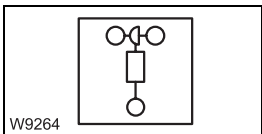

Anemometer not connected

- Connect the anemometer to the electrical power supply; p. 13 - 108.

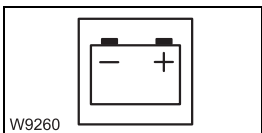

Voltage indicator lamp

The voltage in the superstructure electrical system is too high or too low.

Display of the current voltage; p. 11 - 15, p. 4 - 18.

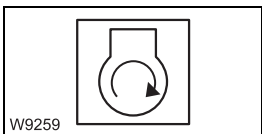

Air intake inhibitor triggered

The air intake inhibitor was triggered because the maximum permissible engine speed was exceeded. It is only possible to start the engine after the air intake inhibitor has been released manually; p. 11 - 21, p. 4 - 23.

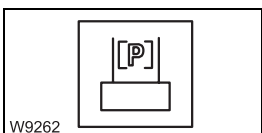

Pre-tensioning the counterweight

The pre-tensioning pressure on the counterweight has dropped too much.

- Pre-tension the counterweight; p. 13 - 74.

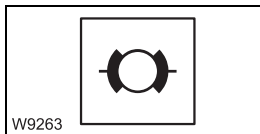

Supply pressure in the brake circuit too low

The pressure in a brake circuit is below approx. 5.5 bar (80 psi). Stop the truck crane and try to find the cause; *Brake supply pressure too low*, p. 5 - 52.

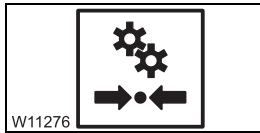

Supply pressure in secondary consumers too low

The supply pressure is below approx. 6.0 bar (87 psi); *Building up supply pressure*, p. 5 - 9.

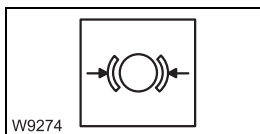

Prompt to brake

- Brake the truck crane; *Prompt to brake*, p. 3 - 39.

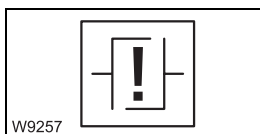

Clutch overloaded

Remove your foot from the accelerator immediately and actuate the service brake; *Clutch: Overload*, p. 5 - 56.

Exiting the submenu



You can exit the submenu at any time.

- Press button (1) once.
The menu that was open before you opened the *Warning* submenu opens.

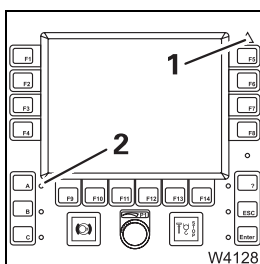

If the same warning messages are still present, the lamps (1) and (2) light up.

If no warning message is present, both lamps will have gone out.

Both lamps start to flash again as soon as a new warning message occurs.



12.4.10

Error submenu

ECOS differentiates between error messages and warning messages (warning messages  p. 12 - 102).

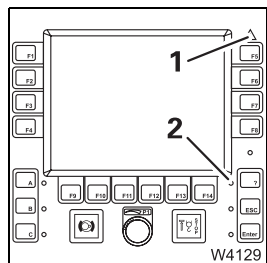

In the event of an error message the lamps (1) and (2) flash.

More information on error messages;  *Error messages*, p. 15 - 33.

41005067

12.5

Working range limiter

You can set and monitor four different limitations in the working range limiter submenus:

- a maximum overall height,
- a maximum working radius,
- a maximum slewing angle,
- objects in the working range.

The monitoring of the programmed limiting values can be switched on and off separately.



Danger of accidents due to situations which cannot be monitored

The working range limiter only serves as an additional safety device. Brake the crane movement before contact with the obstacle becomes imminent. Do not drive into the shutdown range. You, the crane operator, are still responsible for monitoring the working range, so that you can react appropriately if situations arise which cannot be monitored electronically.



Danger of accidents due to limit values set too low

When entering the limit values, bear in mind that, even after switching off the engine, movements can still occur that would bring the load into the shutdown range (e.g. due to the load swinging or the boom bending). For this reason, always enter the limit values with sufficient safety distance to the object.



Risk of accidents due to insufficient safety distances

Always observe all safety distances in accordance with the national legal regulations (e.g. concerning electrical cables) even if the working range limiter is switched on.

12.5.1

Opening the Working range limiter submenu

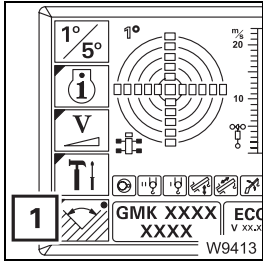

- If required, open the main menu **Esc**.
- The dot in symbol (1) indicates whether limit values are being monitored:
 - **Dot is black:** monitoring switched off
 - **Dot is green:** monitoring switched on
- Press button (1) once.

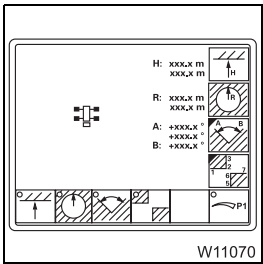

The *Working range limiter* submenu opens.
Units of measurement are displayed – metres (m) or feet (ft).

12.5.2

Viewing current settings

The *Working range limiter* submenu shows active monitoring functions, entered limit values and current values.

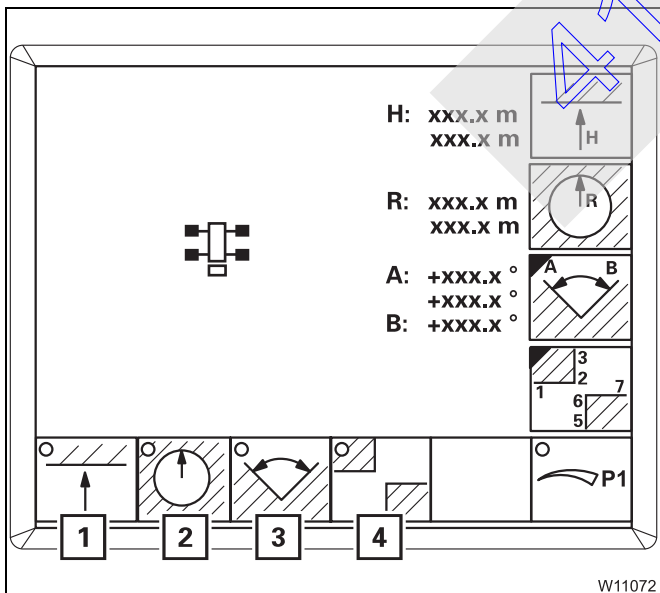

Monitoring on / off

The dots in the symbols (1) to (4) indicate the current status.

- 1 Overall height monitoring
 - 2 Working radius monitoring
 - 3 Slewing angle monitoring
 - 4 Object monitoring
- **Dot is black:** monitoring switched off
 - **Dot is green:** monitoring switched on, the monitored area is displayed; p. 12 - 118.

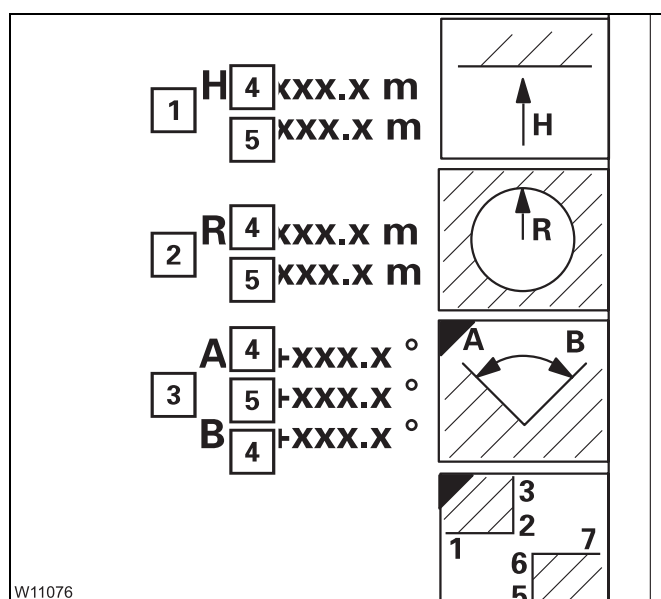

Limit values / Current values

The displays (1) to (3) indicate values for

- 1 Overall height
- 2 Working radius
- 3 Slewing angle

Every display shows the following values:

- 4 Limit value – red
- 5 Current value – blue

With manual input switched on, the display (5) changes; p. 12 - 116.

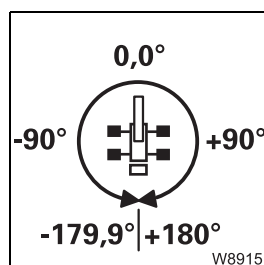

The following applies to the slewing angle display:

0° means that the superstructure is slewed to the rear.

- Angles in the **right-hand semi-circle** are displayed as **positive** values (0° to +180.0°).
- Angles in the **left-hand semi-circle** are displayed as **negative** values (0° to –179.9°).



Viewing the limit values for object monitoring; *Objects*, p. 12 - 117.

12.5.3

Entering limit values

This section describes how to enter unknown limit values by moving to the shutdown points.

You can enter known limit values directly; *Entering limit values / objects manually*, p. 12 - 116.

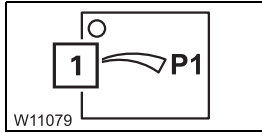

Prerequisite

Manual input must be switched off.

- Press the button (1) repeatedly until the dot turns **black**.



Danger of accidents due to limit values set too low

When entering the limit values, bear in mind that, even after switching off the engine, movements can still occur that would bring the load into the shutdown range (e.g. due to the load swinging or the boom bending). For this reason, always enter the limit values with sufficient safety distance to the object.

Overall height / Working radius

The limit values for the overall height and the working radius are entered in the same way.

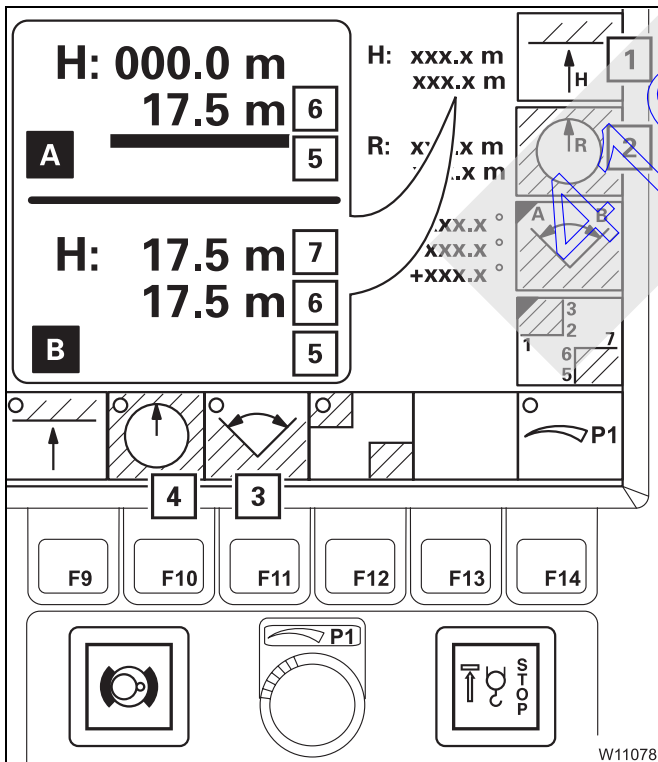

The relevant monitoring function (3) or (4) must be switched off – dot **black**; p. 12 - 118.

- Press the button once
 - 1 for the overall height or
 - 2 the working radius.
- Bar (5) red – input on. Cancel input – press button once.
- (A) – Move the main boom head to just before the shutdown point without a load, e.g. to 17.5 m – value (6).
- (B) – Press the button once.
 - The current value (6) is accepted as the limit value (7).
 - The bar (5) goes out.
- Switch on monitoring; p. 12 - 118.

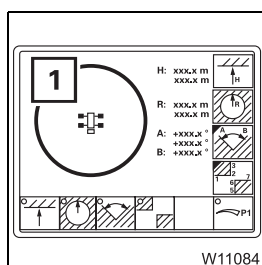

The limit value for the working radius affects the representation of defined objects.
Only points that are within the limit value (1) are displayed.

Slewing angle

Slewing angles are entered in a submenu.

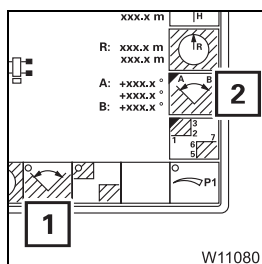

Before entering values, monitoring (1) must be switched off – dot **black**; p. 12 - 118.

- Press button (2) once.
The *Enter slewing angle* submenu opens.

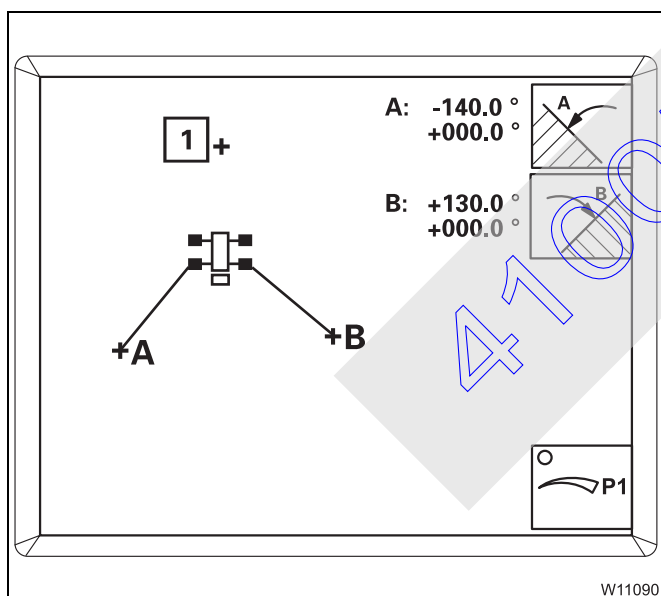

Display of the slewing angles

The cross (1) shows the current position of the main boom.

- The slewing angle **A** limits slewing to the left.
- The slewing angle **B** limits slewing to the right.

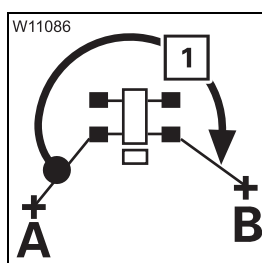

The permissible slewing range is represented by the angle stretching clockwise from **A** to **B**.
Approx. 270° in this illustration – arrow (1).



Entering the permissible slewing range

You must enter the slewing angles **A** and **B** separately.



Risk of accidents due to incorrectly set slewing angles

Always slew the main boom to the shutdown point from the right with slewing angle **A** and from the left with slewing angle **B**.

This prevents slewing into the impermissible range being enabled.

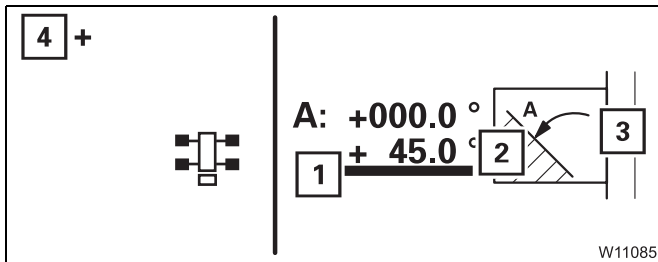

Slewing angle A:

- Press button (3) once.
Bar (1) red – input on. Cancel input – press button **Esc** once.

- Slew the main boom (4) to the shutdown point from the right, e.g. value (2) 45°.

- Press the button **Enter** once.
 - The slewing angle **A** is displayed.
 - The value (2) is accepted as the limit value (3).
 - The bar (1) goes out.

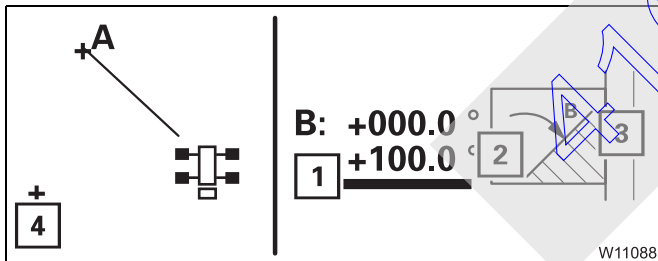
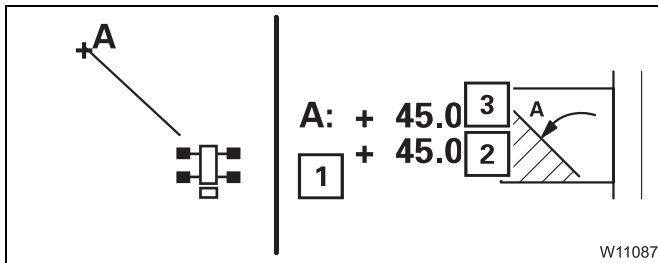

Slewing angle B:

- Press button (3) once.
Bar (1) red – input on. Cancel input – press button **Esc** once.

- Slew the main boom (4) to the shutdown point from the left, e.g. to value (2) 100°.

- Press button **Enter** once.
 - The slewing angle **B** is displayed.
 - The value (2) is accepted as the limit value (3).
 - The bar (1) goes out.

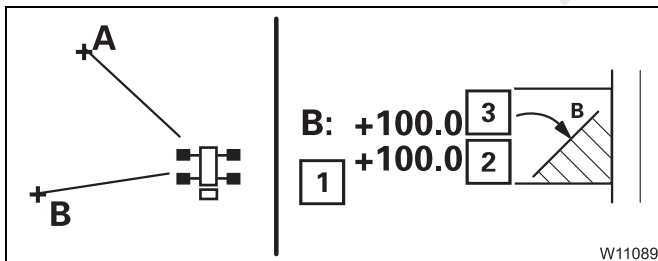

Entering objects

Objects are entered in a submenu.

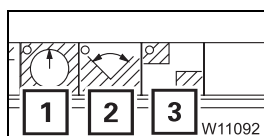

Before entering values, the monitoring functions (1) to (3) must be switched off – dot **black**; p. 12 - 118.

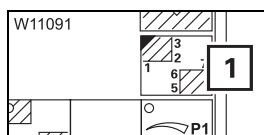

- Press button (1) once.
The *Enter objects* submenu opens.

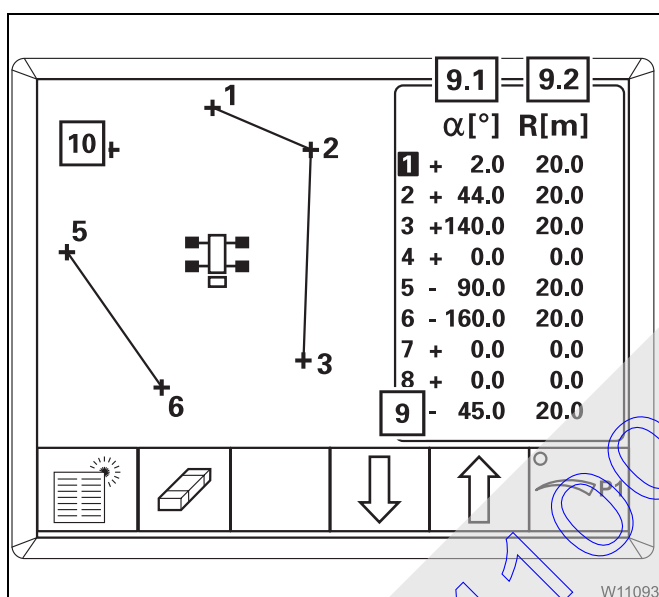

Representation of points and objects

Each point shown is numbered and defined by the point data *slewing angle* (9.1) and *working radius* (9.2) – red.

An object is made up of points that are connected by lines, e.g. the points 1 to 3 and the points 5 and 6).

The cross (10) and the point data (9) show the current position of the main boom – blue.



Only those points are displayed that are located within the entered, maximum working radius. You may need to enlarge the maximum working radius in order to display the point; p. 12 - 116.



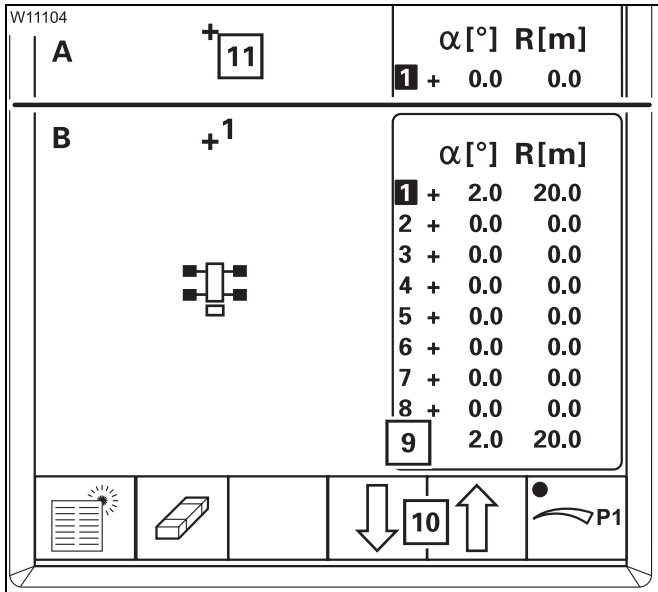

Entering objects

- **(A)** – With the buttons **(10)**, select the first point, e.g. point **(1)** – blue.
- Move the main boom head **(11)** to just before the first point of the object.
- **(B)** – Press button **Enter** once.
 - The point **(1)** is displayed.
 - The current point data **(9)** is accepted for point **(1)**, e.g. 2° and 20 m.

The first point has now been entered.

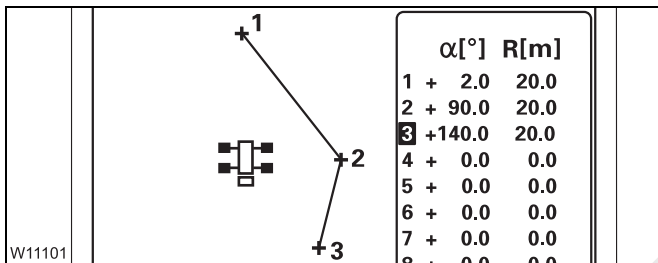

- Enter the next point **(2)** in the same way, e.g. +90° and 20 m.

The point is connected with point **(1)** – an object has been entered.

To enlarge the object, you can enter subsequent points 3 to 8, e.g. point **(3)**.

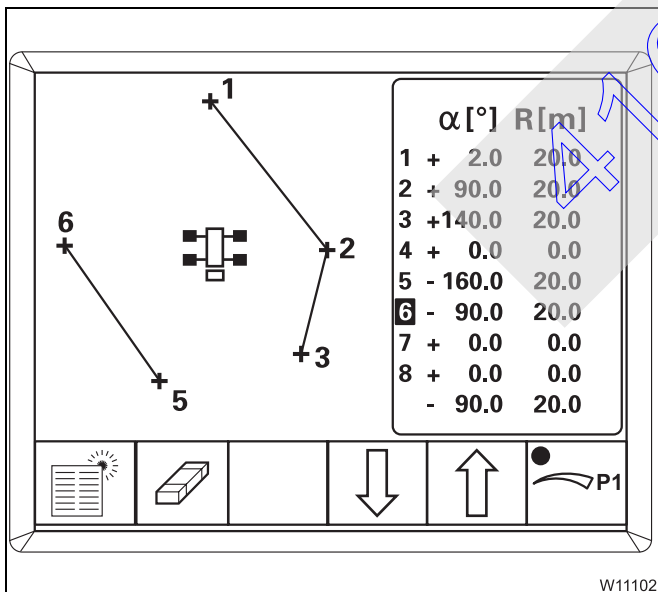

You can also add objects:

- Delete the subsequent point, e.g. point **(4)** – point data 0.0; p. 12 - 115.
- Enter the next point, e.g. point **(5)** at -160° and 20 m.

This point **(5)** is the first point for the new object. The following point is added to this object, e.g. point **(6)**.

Deleting points

You can delete selected, individual points or delete all points at once.

A			B		
	α [°]	R[m]		α [°]	R[m]
1 +	2.0	20.0	1 +	0.0	0.0
2 +	90.0	20.0	2 +	0.0	0.0
3 +	140.0	20.0	3 +	0.0	0.0
4 +	0.0	0.0	4 +	0.0	0.0
5 +	0.0	0.0	5 +	0.0	0.0
6 +	0.0	0.0	6 +	0.0	0.0
7 +	0.0	0.0	7 +	0.0	0.0
8 +	0.0	0.0	8 +	0.0	0.0
-	90.0	20.0	-	90.0	20.0

(A) – Selected points

- Press button (1) once.

The selected point is deleted, e.g. point (4) – point data 0.0.

(B) – All points

- Press the button (2) once – symbol (3) appears.

You can cancel the process with the button .

- Press button once – all points are deleted.

41005067

12.5.4

Entering limit values / objects manually

Limit values

The limit values for the overall height, the working radius, and the slewing range are entered in the same way.

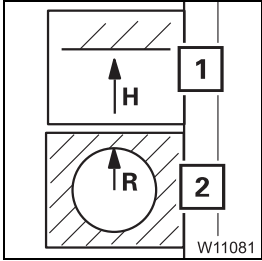

– For overall height / working radius

- Press the button once
 - 1 for the overall height or
 - 2 the working radius.

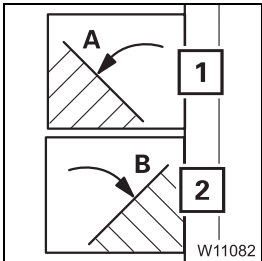

– For slewing angles

- Open the *Enter slewing angle* submenu.
- Press the button once
 - 1 for slewing angle A or
 - 2 for slewing angle B.

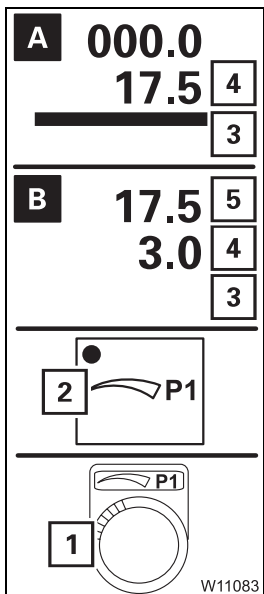

Entering a limit value

The bar (3) is red – input on.
To cancel the input – press button **Esc** once.

- Press the button (2) once – the dot turns **green**, manual input on.
- (A) – Enter the new limit value, e.g. 17.5, with the switch (1) on display (4).
- (B) – Press button **Enter** once.
 - Display (5) = new limit value
 - Display (4) = current value, e.g. 3.0
 - Bar (3) goes out
 - Dot (2) **black**, manual input off

Objects

Objects are entered in a submenu.

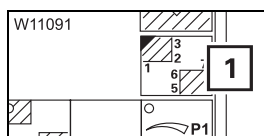

- Press button (1) once.
The *Enter objects* submenu opens.

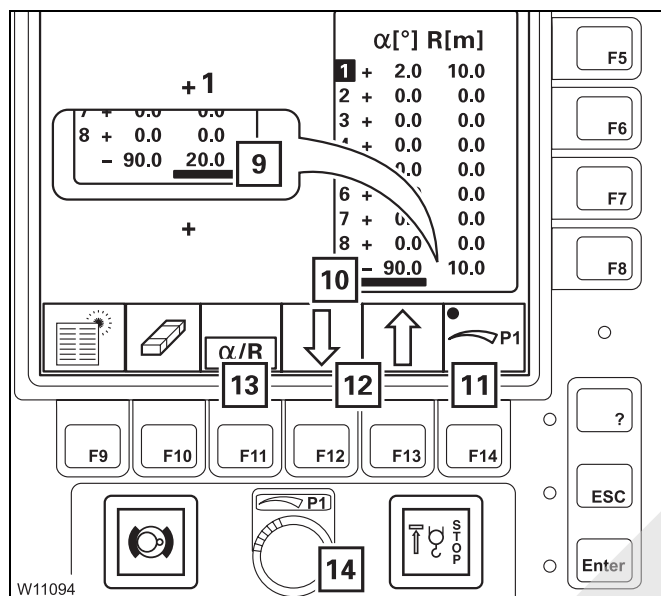

- With the buttons (12), select the desired point, e.g. point (1) – blue.
- Press the button (11) once – the dot turns **green**, manual input on.
- With the button (13) select
 - the slewing angle – bar (10) red or
 - the working radius – bar (9) red, input on. Cancel input – press button **ESC** once.
- Enter the new values, e.g. -90.0° and 20.0 m with the switch (14).

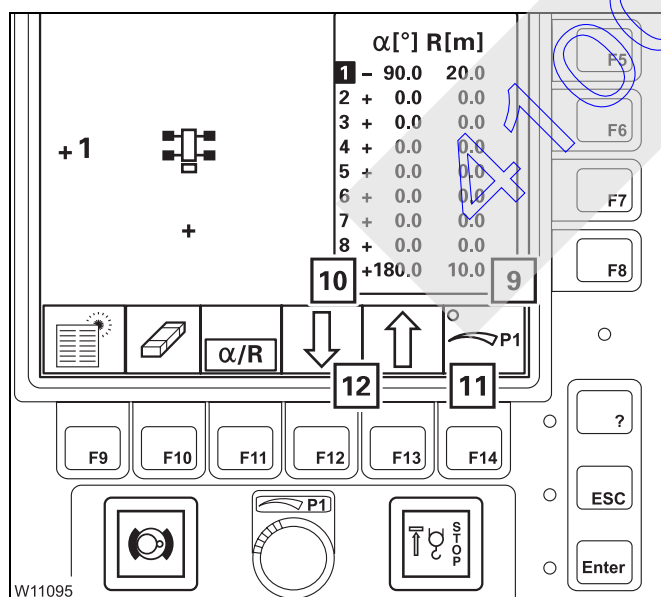

- Press button **Enter** once.
The new values for point (1) are accepted.
You can enter additional points in the same way – button (12).
- To end your input, press the **Enter** button once.
 - Bar (9) or (10) goes out – display = current main boom position
 - Dot (11) **black** – manual input off

12.5.5

Switching monitoring functions on / off

After turning on the ignition, all monitoring functions are switched on that were on before the ignition was turned off.

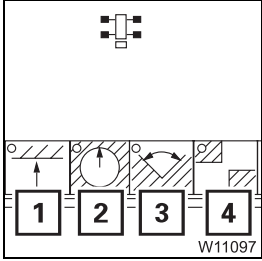

- Press the buttons for the required monitoring functions once.

- | | |
|-------------------------|-------------------------|
| 1 Overall height | 2 Working radius |
| 3 Slewing angle | 4 Objects |

Dot is green: monitoring switched on
Dot is black: monitoring switched off



Danger of accidents due to incorrectly set limit values

After switching on the monitoring function, slowly approach all limit values and check that they are switched off in time.

If necessary, enter new values with larger safety distances.



With monitoring switched on, the speed of all power units is limited to 50%. Limits below 50% continue to be active. We recommended limiting the slewing gear speed to between 30% and 50%.

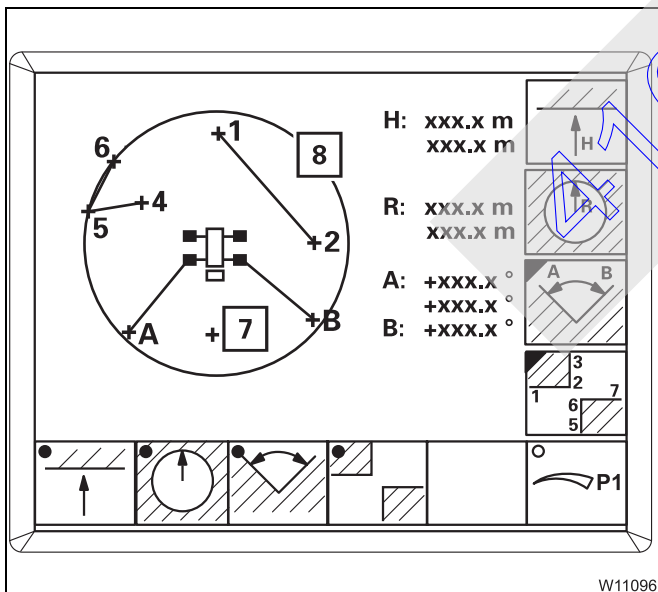

The monitored area is displayed:

- **Working radius**
Circle (8) – red.
- **Permissible slewing angle**
Circle sector, clockwise from A to B.
- **Objects**
Points and lines, e.g. 1 to 2 and 4 to 6.
- **Overall height**
No display.

The current main boom position (7) is always displayed.



It is impossible to move behind a defined object whenever a monitoring function is switched on.

12.5.6

Shutdown by working range limiter

If a limit value is reached, SLI shutdown occurs. All movements that would go closer to the limit value are disabled. Shutdown remains active even if you switch off the monitoring function.

Shutdown point reached for	Disabled movements
Overall height	<ul style="list-style-type: none"> - Raising - Extending - Lowering the hoist - Derricking the lattice extension
Working radius	<ul style="list-style-type: none"> - Lowering - Extending - Lifting the hoist - Derricking the lattice extension
Slewing angle A	<ul style="list-style-type: none"> - Slewing to the left
Slewing angle B	<ul style="list-style-type: none"> - Slewing to the right
Objects	<p>Depending on the position of the object:</p> <ul style="list-style-type: none"> - slewing to the left or right - lowering - extending - lifting the hoist - derricking the lattice extension



The SLI also shows an error message. To enable the movements, you must leave the shutdown range and acknowledge the error message; see *Table of error codes*, p. 15 - 28.



Danger of accidents by overriding shutdown procedures

Only override the SLI if it is absolutely necessary and you have a clear view of the danger area. Bear in mind that, due to the boom bending for example, the overall height is increased if you set down the load.

If you override the SLI, the shutdown is overridden and all movements are enabled.

Blank page

41005067

12.6

Work break

12.6.1

Short work breaks



Risk of accidents due to suspended loads

Never turn off the engine with a load suspended. You must have the control levers at hand in order to intervene at any time.

Always set down the load before you leave the crane cab.

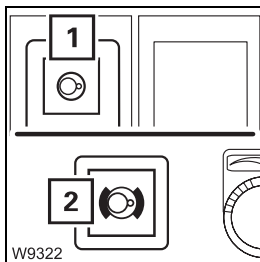

- Switch off the slewing gear.
 - The lamp in the button (1) must light up dimly.
 - The lamp (2) must light up – slewing gear brake engaged.

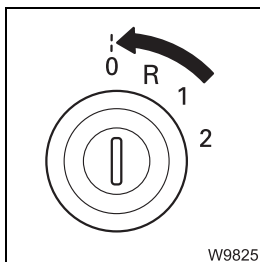

Switch the engine off, turn the ignition key to position **0** and remove it.

Ensure that no unauthorised persons can operate the truck crane;

▣▣▣▣ ➔ *To secure the truck crane, p. 12 - 122.*

12.6.2

Work breaks of more than 8 hours

- Retract all telescopic sections
- Set down the main boom on the boom rest.

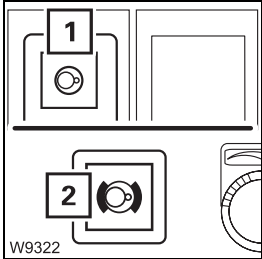

- Switch off the slewing gear.
 - The lamp in the button (1) must light up dimly.
 - The lamp (2) must light up – slewing gear brake engaged.

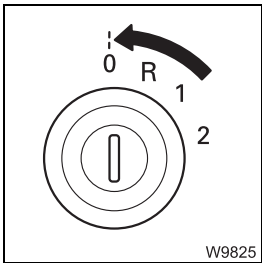

- Switch the engine off, turn the ignition key to position 0 and remove it.

- Switch off all current consumers.

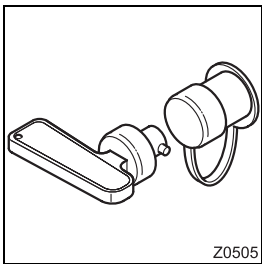

- Switch off the battery master switch. This does not interrupt the run-down period of the heater.

To secure the truck crane

- Secure the truck crane against unauthorised use by:
 - stowing away the hand-held control in the crane cab,
 - removing the ignition key and
 - locking the crane cab.



Danger due to unauthorised use

Close the hand-held control before you leave the truck crane. In this way you can prevent unauthorised persons from starting the engine with the hand-held control.

12.7

Heating and air-conditioning system

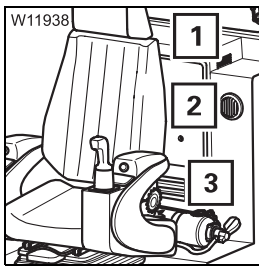

- Do not cover the grilles (1), (2) and (3).
 - Air is drawn in through the grilles (2) and (3).
 - The grille (1) is used to ventilate the electronics.

12.7.1

Standard heating system

Switching on

- Start the engine. The heating output is only provided when the engine is running.

Heating

You must set the fan, fresh air / recirculated air and the temperature.

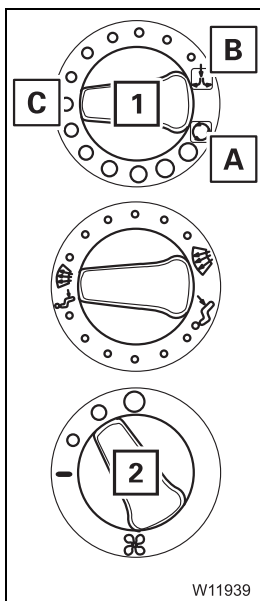

Setting the fan

- Turn the switch (2) to the required level 1 to 4, depending on the desired air quantity.

Setting fresh air / recirculated air / mixed air

You can set which air is sucked in by the fan.

- Turn the switch (1) to the position for
 - A** Recirculated air – air is sucked in from the driver's cab. Change to fresh air every so often to ensure that oxygen is supplied.
 - B** Fresh air – outer air is sucked in.
 - C** Mixed air – outer air and air is sucked in from the driver's cab. The percentage of the corresponding air type is increased continuously by turning the switch in the direction (B) or (A).



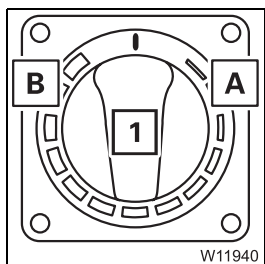

Setting the temperature

- Turn the switch (1) in the required direction.
 - A** colder
 - B** warmer

Air distribution

You can allow the air to flow out from various air vents.

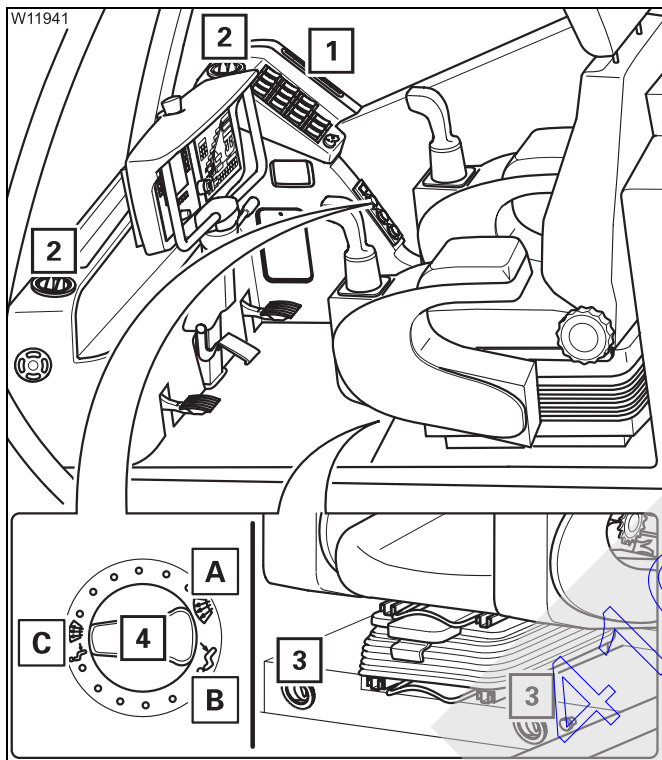

- Turn the switch (4) to the position for the required air vents.

- A** Air vents (1), (2), front window, centre
- B** Air vents (3), cab floor
- C** Air vents (1), (2), (3)

You can adjust the air vents (2) and (3).

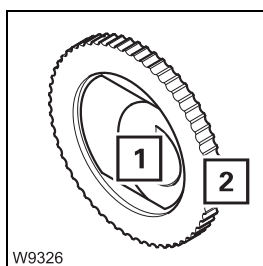

Adjusting the air vents

- 1** – To open: press in and position lengthwise
- To close: position crosswise
- To direct the air flow: in intermediate position
- 2** – To direct the air flow: turn

Switching off

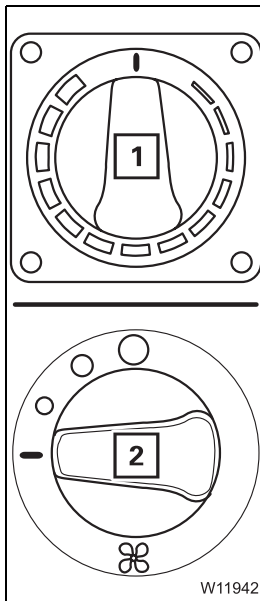

Switching off the heater

- Turn the switch (1) as far as it will go in an anti-clockwise direction, to *Cold*.

Switching off ventilation

- Turn the switch (2) to the level 0.

12.7.2

Air-conditioning system

You can use the air-conditioning system to cool and dry the air in the crane cab.

Warnings

Do not cool the air in the crane cab too much.

The difference between the outside temperature and the inside temperature should be at the most 10 °C to 14 °C (18 °F to 25 °F).

If cooling is too severe, you may frequently feel physically uncomfortable, usually only after you leave the cool room.

Avoid having cold air blowing directly onto your body.

When using recirculated air, you should switch over to fresh air mode to ensure a fresh supply of oxygen at the same time. Adjust the cooling output to your actual needs:

if the truck crane has been exposed to strong sunlight for a long period of time, for example, the air conditioning system should initially be operated at the highest blower level with the engine running.

The door or at least the windows should be left open for a short while to air thoroughly. The cooling-down procedure can be accelerated by increasing the engine speed.

If the air-conditioning system is operated continuously, close the windows and doors to ensure sufficient cooling.

Set the fan to a lower level once the inside temperature has reached the desired temperature.



Switching on / off

- Start the engine. The air-conditioning only operates when the engine is running.
- Switch off the auxiliary heaters.
 - Auxiliary water heater; ■■■► p. 12 - 133,
 - Auxiliary air heater; ■■■► p. 12 - 134.

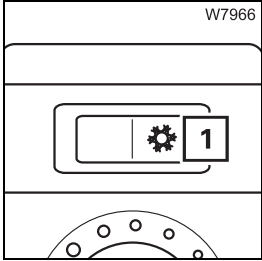

- **To switch on:** • press the switch next to symbol (1)
- **To switch off:** • press the switch opposite symbol (1)

Cooling

The illustration only shows one example of setting. Always adjust the setting to the current conditions.

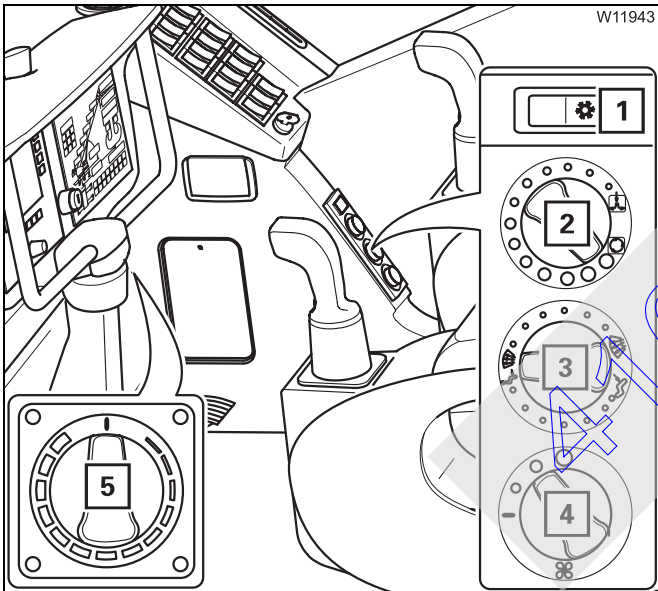

- Press the switch next to symbol (1).
- Turn the switch (5), as far as it will go, to *Cold*.
- Turn the switch (4) to the required level.
- Set the air distribution with switch (3) – open the air vents if necessary.
- If switch (2) is set to recirculated air, cooling will be quicker. There will be no oxygen supplied, however.

Drying the air

You can dry the air in the crane cab.
Here, however, no heating capacity, or only a low heating capacity level, is reached.

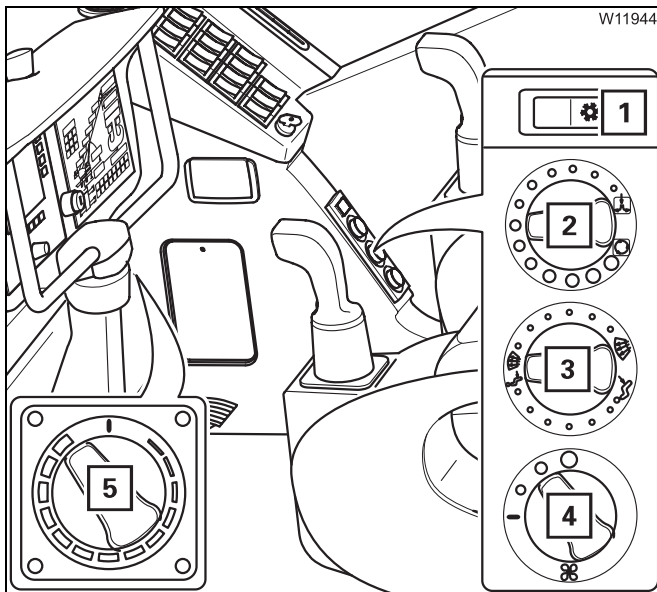

- Press the switch next to symbol (1).
- Turn the switch (5), as far as it will go, to *Warm*.
- Turn the switch (4) to the required level.
- Adjust the setting for fresh air / recirculated air to the current conditions (humidity and temperature of the outer air) by using switch (2).
- Set the air distribution with switch (3) – open the air vents if necessary.

When drying, the air conditioning and the heating work against each other.
After drying, switch off the device you do not require.

12.7.3

Auxiliary water heater



The batteries will run down if you operate the auxiliary heater with the engine switched off. You must recharge the batteries at shorter intervals if you use the auxiliary heater frequently.

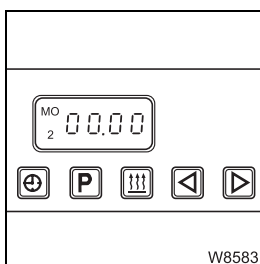

You can use the auxiliary water heater to:

- either preheat the engine or
- preheat the engine and crane cab simultaneously.

The auxiliary heater is supplied from a separate tank;  p. 12 - 5.



Preheating the engine

If only the engine is to be preheated, adjust the heating system as follows:

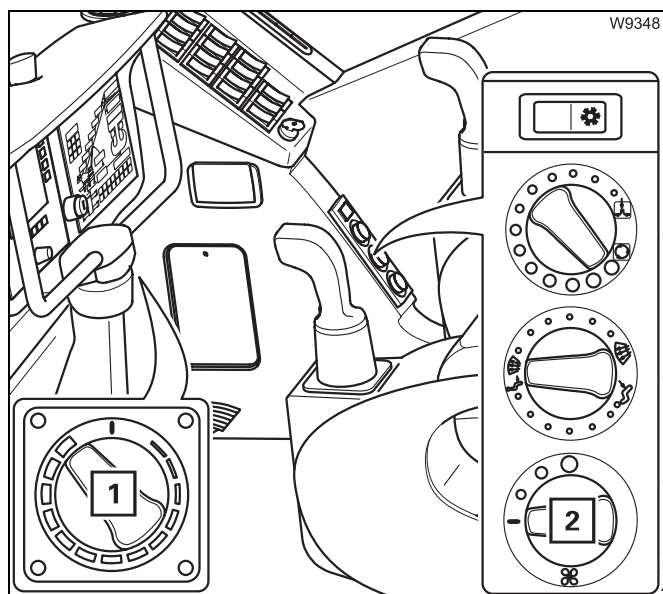

- Switch (1) to *warm* setting.
- Switch (2) to *fan off* setting.

Preheating the crane cab

If the crane cab is to be preheated in addition to the engine, adjust the heating system as follows:

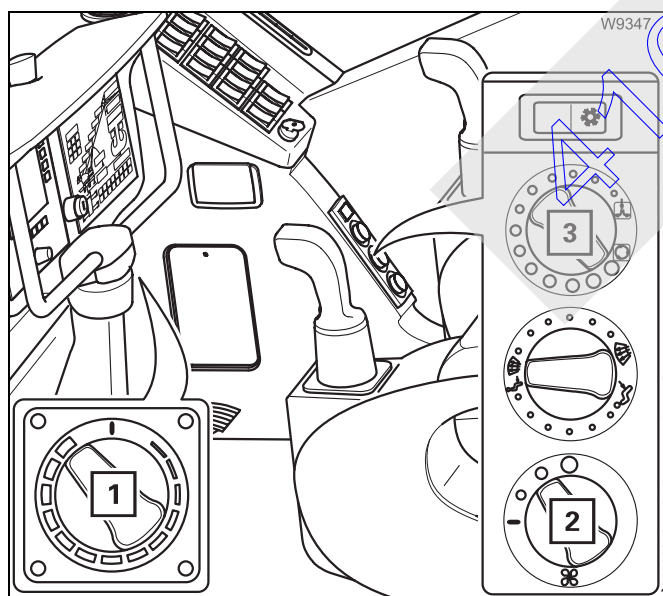

- Switch (1) to *warm* setting.
- Switch (3) to the *recirculated air* symbol.
- Turn the switch (2) to the required fan level.
- Open the air vents; see p. 12 - 124.



The amount of time required to preheat the engine is increased significantly by simultaneously heating the crane cab.

Switching on

- Check whether the auxiliary heater is allowed to be operated at the current site of the truck crane before switching it on. Find out whether there are any sources of danger that could result in explosions.



Danger of explosions when operating the auxiliary heater

The auxiliary heater is not allowed to be operated:

- at service stations and tank farms,
- at places where inflammable gases or vapours can be found or may form (e.g. at places where fuel is stored and at chemical factories),
- at places where explosive dust can be found or form (e.g. coal dust, wood dust, grain dust).



Danger of suffocation when operating the auxiliary heater

Do not use the auxiliary heater in closed spaces (e.g. a garage).



This section describes how to switch on the heater manually. You can also have the auxiliary heater switch on automatically; *Storing the heating start*, p. 12 - 131.

- Turn on the ignition; *Switch on the ignition*, p. 11 - 8.
- Press button (1) once.
The auxiliary heating switches itself on – the control field lights up.

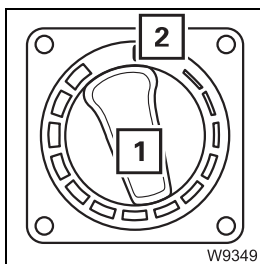
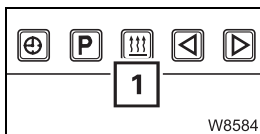

Setting the temperature

- Turn the switch (1) to the required temperature.

When the switch (1) is turned as far as possible (2) (*cold*), the auxiliary heater is not switched on.

The auxiliary heater only supports the heating capacity of the standard heating system as long as the engine is cold. When the engine is warm, the heater is switched off. The pump for the auxiliary heater continues to run, however, until you switch the auxiliary heater off.



Always switch off the auxiliary heater when you turn off the truck crane when the battery master switch is switched on. In this way, you prevent the auxiliary heater from restarting and running down the batteries after the engine has cooled down.



Setting the day and time

Always set the current time and weekday. These settings are required for the correct activation point of the automatic heating start.



If the power supply is interrupted, all symbols in the display will flash and you must set the time and day again.

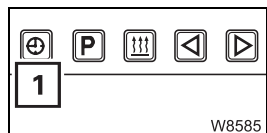

- Press the button (1) for longer than 2 seconds. The displayed time flashes, e.g. 10.00.



- Set the current time on the flashing display, e.g. 14.00 hrs.

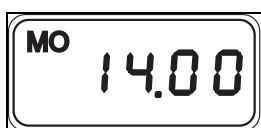

- Wait five seconds. The new time is saved and then the weekday flashes (e.g. **MO** for Monday).



- Set the current day of the week on the flashing display.

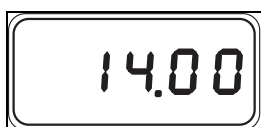

The display stops flashing after five seconds and the current time is displayed. The day of the week disappears.

The time and day of the week have been set.

41005067

Storing the heating start

The automatic heating is only started at the required time when the time and day of the week have been set correctly;  p. 12 - 130.

You can set three different automatic heating starts – up to seven days in advance.



If you call up values in order to change them during the following setting procedure, they flash for five seconds. The entry must be made within this period of time. The value stops flashing after five seconds and is saved as the new value.

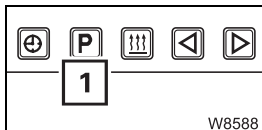

- To retrieve a storage location, press the button (1) once.



Flashing displays:

- the retrieved storage location, e.g. 2 and
- the heating start stored last, e.g. 6.00 am.



- Set the time for the required heating start, e.g. 8.00 am.



Wait for approx. 5 seconds until the day of the week for the heating start flashes, e.g. **MO** for Monday.



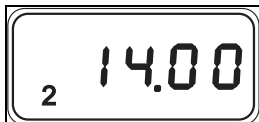

- Set the day of the week for the required heating start.



Wait for approx. 5 seconds until the current time is shown, e.g. 14.00 hrs. Now the new heating start has been stored and switched on.



If you wish to store one or two further heating starts, retrieve a new storage location using the  button and repeat the procedure.

After you have stored the heating start, you can also set the heating period;  p. 12 - 132.



Setting the heating period

After an automatic start, the heater switches itself off as soon as the set heating period has elapsed.
The heating period applies to all stored heating starts.

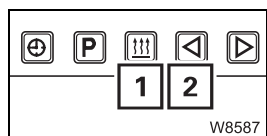

- Switch off the heating using the button (1).
- Press the button (2) for longer than 3 seconds.



The last set heating period, e.g. 27 minutes, now flashes for 5 seconds in the display.



- Set the required heating period on the flashing display. You can set a heating period of 10 to 120 minutes.

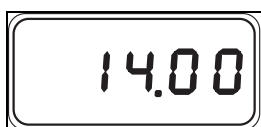

Wait for approx. 5 seconds until the current time is shown, e.g. 14:00 hrs.
A new heating period has now been set.

Switching heating start on / off

To switch on an automatic heating start, you must retrieve the corresponding storage location.

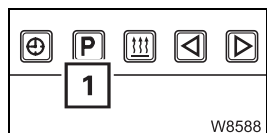

- To retrieve a storage location, press the button (1) once.

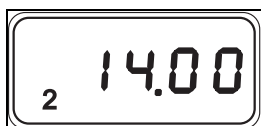

The display flashes for 5 seconds and a storage location is shown (e.g. 2).
The heating start at this storage location is now activated.

To activate a different heating start, press the **P** button repeatedly until the required storage location is displayed. This heating start is activated as soon as the display stops flashing.

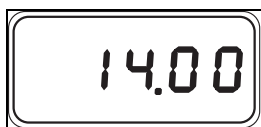

To deactivate the automatic heating start, press the **P** button repeatedly until no storage location is displayed any longer.

Switching off

This section only describes how to switch off the heater manually. The auxiliary heater is switched off after a certain time if it was switched on automatically. You can set this heating period;  *Setting the heating period*, p. 12 - 132.

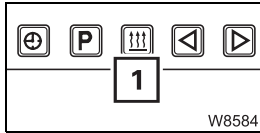

- To **switch off**, press the button (1) once. The auxiliary heater is switched off immediately.



If you turn off the ignition while the auxiliary heater is in operation, the auxiliary heater continues to run for a certain period of time. You can set this remaining time;  *Setting the remaining time*, p. 12 - 133.

Setting the remaining time

If the ignition is turned off while the auxiliary heater is running, the heater continues to run for the remaining time.

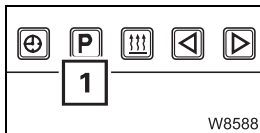

- Switch on the heater using the (1) button.

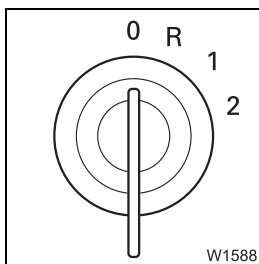

- Turn off the ignition.



The heater continues to run and the remaining run time set last flashes, e.g. 48 minutes.



- Set the required remaining run time on the flashing display. You can set a remaining run time of 1 to 120 minutes.

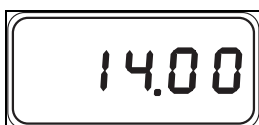

- Wait for 5 seconds until the current time is shown. The remaining run time is now set.

12.7.4

Auxiliary air heater

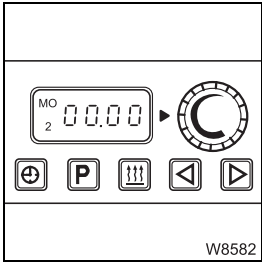

You can use the auxiliary air heater to preheat the crane cab or provide additional heating.

The auxiliary heater is supplied from a separate tank;  p. 12 - 5.

The batteries will run down if you operate the auxiliary heater with the engine switched off. You must recharge the batteries at shorter intervals if you use the auxiliary heater frequently.

Switching on

To switch the auxiliary heater on and off, you can:

- switch the auxiliary heater on and off manually, for this purpose the ignition must be turned on
- or set an automatic heating start and heating period with the timer;
 *Additional functions*, p. 12 - 135.
- Before switching on the heater, check whether it is allowed to be operated at the current site of the truck crane. Find out whether there are any sources of danger that could result in explosions.



Danger of explosions when operating the heater

The heater must not be operated:

- at service stations and tank farms,
- at places where inflammable gases or vapours can be found or may form (e.g. at places where fuel is stored and at chemical factories),
- at places where explosive dust can be found or form (e.g. coal dust, wood dust, grain dust).



Danger of suffocation when operating the heating

Do not operate the heater or the heater with the timer in enclosed rooms (e.g. garages).

- Turn on the ignition;  *Switch on the ignition*, p. 11 - 8.
- Press button (1) once.
The auxiliary heating switches itself on – the control field lights up.

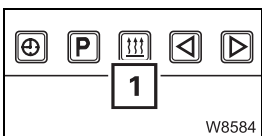

Temperature

You can preselect a temperature for the crane cab. The preselected temperature is automatically set and maintained.

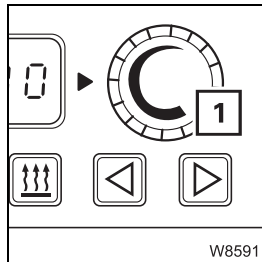

Increasing the temperature:

- turn the switch (1) clockwise.

Reducing the temperature:

- turn the switch (1) anti-clockwise.

The higher the selected temperature is, the faster the fan of the auxiliary heater runs.

Switching off

You can switch off the auxiliary heater manually at any time.

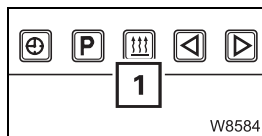

- Press button (1) once. The auxiliary heater is switched off immediately.

Additional functions

The auxiliary air heater has the same functions as the auxiliary water heater.

- Setting the time / day ■■■▶ p. 12 - 130
- Storing the heating start ■■■▶ p. 12 - 131
- Switching heating start on / off ■■■▶ p. 12 - 132
- Setting the heating period ■■■▶ p. 12 - 132
- Setting the remaining time ■■■▶ p. 12 - 133

Blank page

41005067

13 Rigging work

13.1	Rigging work checklists for crane operation with the main boom	13 - 1
13.1.1	CHECKLIST: Rigging	13 - 1
13.1.2	CHECKLIST: Unrigging	13 - 5
13.2	Choosing a suitable site	13 - 9
13.2.1	Determining the required ground bearing area	13 - 9
13.2.2	Safe distance from slopes and pits	13 - 12
13.2.3	Earthing the truck crane	13 - 13
13.2.4	Safe distance from electrical lines	13 - 14
13.3	Rigging work after driving with a trailer	13 - 17
13.3.1	Switching off the boom floating position	13 - 17
13.3.2	Switching off the slewing gear freewheel	13 - 18
13.3.3	Switching off boom pre-tensioning	13 - 19
13.4	Connecting / disconnecting the hand-held control	13 - 20
13.5	Starting the engine for driving for rigging work	13 - 21
13.5.1	Starting / turning off the engine with the hand-held control	13 - 21
13.5.2	Starting / turning off the engine from the crane cab	13 - 23
13.6	Outriggers	13 - 25
13.6.1	CHECKLIST: Extending the outriggers	13 - 25
13.6.2	CHECKLIST: Retracting the outriggers	13 - 27
13.6.3	Permissible outrigger spans	13 - 28
13.6.4	Preparing the truck crane	13 - 29
13.6.5	Setting the spans	13 - 30
13.6.6	Extending / retracting outriggers	13 - 32
13.6.7	Moving the outrigger pads into working / driving position	13 - 38
13.6.8	Enlarging the ground bearing area	13 - 39
13.6.9	Extending / retracting supporting cylinders	13 - 41
13.6.10	Levelling the truck crane on outriggers	13 - 46
13.6.11	Levelling the free-standing truck crane	13 - 51
13.6.12	Outrigger pressure display	13 - 53
13.7	Rigging / unrigging the counterweight	13 - 55
13.7.1	Counterweight parts	13 - 55
13.7.2	Identification	13 - 57
13.7.3	Slings points	13 - 58
13.7.4	CHECKLIST: Rigging counterweight	13 - 59
13.7.5	CHECKLIST: Unrigging counterweight	13 - 60
13.7.6	Assembling counterweight versions	13 - 61
13.7.7	counterweight hoist unit	13 - 72
13.7.8	Removing / installing the counterweight on the turntable	13 - 77
13.7.9	Setting down counterweight for driving the truck crane	13 - 80

13.7.10	Slewing with rigged counterweight	13 - 82
13.8	Rigging work on the main boom	13 - 85
13.8.1	Hook block on the bumper	13 - 85
13.8.2	Hook block on a separate vehicle	13 - 87
13.8.3	Reeving and unreeving the hoist rope	13 - 90
13.8.4	Possible reeving methods on the main boom	13 - 96
13.8.5	Installing / removing the lifting limit switch	13 - 102
13.8.6	Locking / Unlocking the lifting limit switch	13 - 106
13.8.7	Anemometer and air traffic control light	13 - 108
13.9	Other rigging work	13 - 111
13.9.1	Rigging in free on wheels working position	13 - 111
13.9.2	Railings on the turntable	13 - 113
13.9.3	Mirror for crane operation	13 - 114

41005067

13

Rigging work

If the truck crane on the site has already been rigged, proceed according to the *CHECKLIST: Inspections prior to crane operation*, p. 12 - 1.

13.1

Rigging work checklists for crane operation with the main boom



This checklist is not a complete set of operating instructions. There are accompanying operating instructions which are referred to by cross-references.

Observe the warnings and safety instructions specified there.

13.1.1

CHECKLIST: Rigging

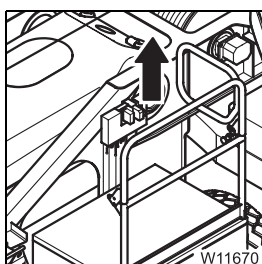
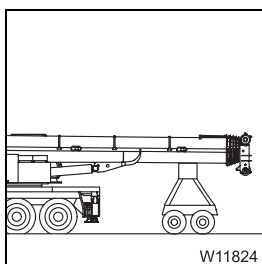
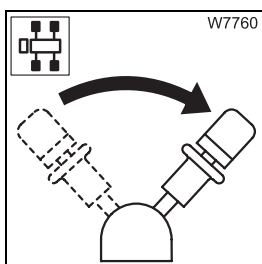

1. Choose a suitable site; ■■■► *Choosing a suitable site*, p. 13 - 9.
2. Check that the parking brake is engaged – if necessary, engage the parking brake.
3. **If the main boom is resting on a trailer:**
 - Switch off the boom floating position; ■■■► p. 13 - 17,
 - Switch off the slewing gear freewheel; ■■■► p. 13 - 18,
 - If necessary, switch off boom pre-tensioning; ■■■► p. 13 - 19.
4. Folding out the tread grid on the turntable; ■■■► p. 13 - 113



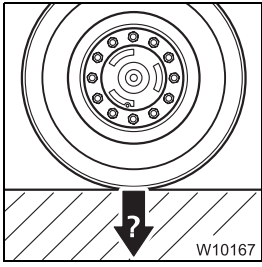

5. For the free on wheels working position

- Check whether the tyre pressure had been correctly set; ||||▶ p. 8 - 5.
- Check whether the ground will support the maximum axle loads; ||||▶ *Weight and axle loads*, p. 8 - 3; ||||▶ *Determining the required ground bearing area*, p. 13 - 9.



Danger of overturning if the truck crane is free on wheels

When the truck crane is free on wheels, the superstructure may not be turned.

For the *free on wheels* working position, the truck crane is first supported and fully rigged. The truck crane is then placed on the wheels.

For this reason, always follow all items in this checklist.

This prevents the truck crane from overturning when slewing.

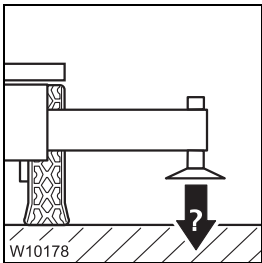

- 6. Check whether the ground will support the maximum occurring outrigger pressures; ||||▶ *Determining the required ground bearing area*, p. 13 - 9.**

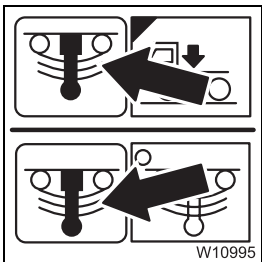

- 7. Deactivate (lock) the suspension.**

The symbol  must be red (suspension off); ||||▶ p. 5 - 15.

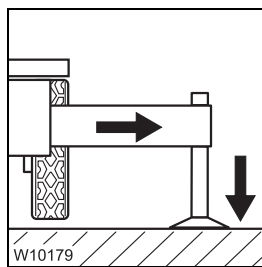

- 8. Support the truck crane with the outrigger span required for the job according to the *Lifting capacity table* and raise until none of the wheels touches the ground; ||||▶ *Outriggers*, p. 13 - 25.**

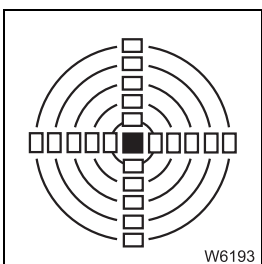

- 9. Align the truck crane horizontally; ||||▶ p. 13 - 46.**

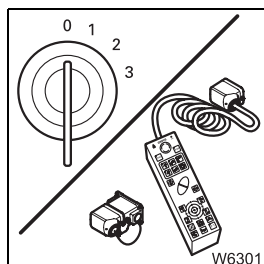

- 10.** Turn off the engine for driving and remove the hand-held control;
- ▣▣▣▣▶ *Starting / turning off the engine with the hand-held control*, p. 13 - 21,
 - ▣▣▣▣▶ *Disconnecting the hand-held control*, p. 13 - 20.

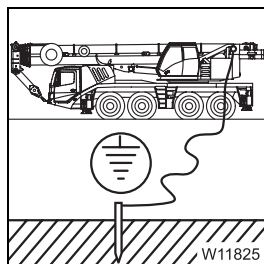

- 11.** Earth the truck crane, if necessary; ▣▣▣▣▶ *Earthing the truck crane*, p. 13 - 13.

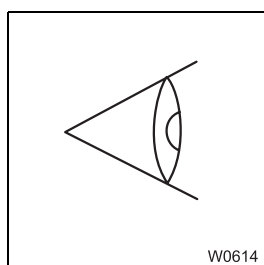

- 12.** Inspect the truck crane, while looking out in particular for any leaking fluids (oil, fuel or water).

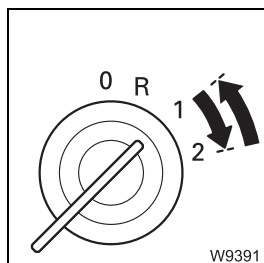

- 13.** Start the engine for crane operation; ▣▣▣▣▶ p. 11 - 12.

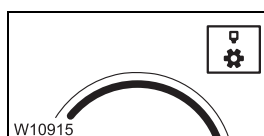

- 14.** Switch off the houselock, if necessary; ▣▣▣▣▶ *Switching off the houselock*, p. 12 - 16.

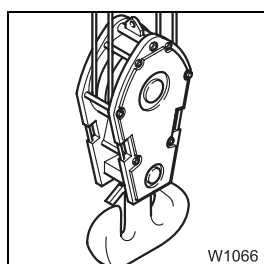

- 15.** Pick up the hook block and re-reeve the hoist rope, if necessary;
- ▣▣▣▣▶ *Hook block on a separate vehicle*, p. 13 - 87,
 - ▣▣▣▣▶ *Hook block on the bumper*, p. 13 - 85,
 - ▣▣▣▣▶ *Reeving and unreeving the hoist rope*, p. 13 - 90.



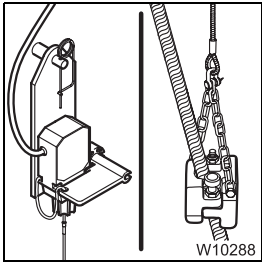

16. Install the lifting limit switch; ||||▶ p. 13 - 102.

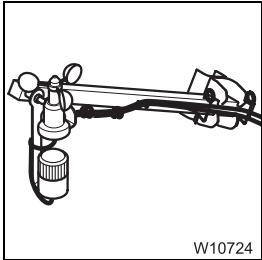

17. Install the anemometer and air traffic control light; ||||▶ p. 13 - 108.

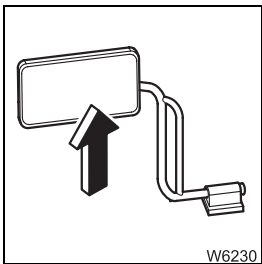

18. Fold out and adjust all mirrors for crane operation; ||||▶ p. 13 - 114.

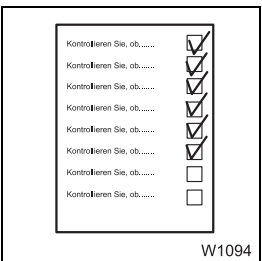

19. Perform all the required checks prior to crane operation; ||||▶ *CHECKLIST: Inspections prior to crane operation, p. 12 - 1.*

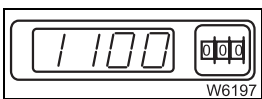

20. Enter the current rigging mode on the SLI; ||||▶ p. 12 - 21.

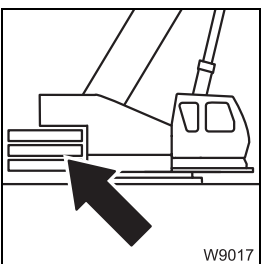

21. With the SLI adjusted accordingly, rig the counterweight version required for the operation according to the *Lifting capacity table*; ||||▶ *CHECKLIST: Rigging counterweight, p. 13 - 59.*

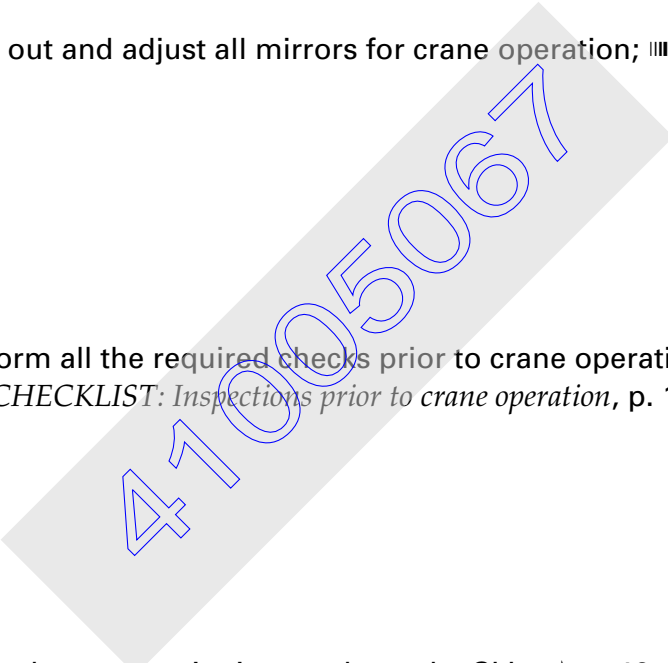

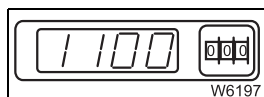

22. Enter the current rigging mode with the newly rigged counterweight version on the SLI; p. 12 - 21.

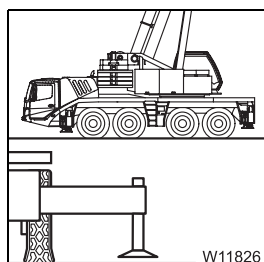

23. **For the free on wheels working position**
- Slew the superstructure backwards to the 0° position
 - Level the truck crane
 - Set the truck crane on the wheels
- Rigging in free on wheels working position*, p. 13 - 111.

13.1.2

CHECKLIST: Unrigging



This checklist is not a complete set of operating instructions. There are accompanying operating instructions which are referred to by cross-references.

Observe the warnings and safety instructions specified there.

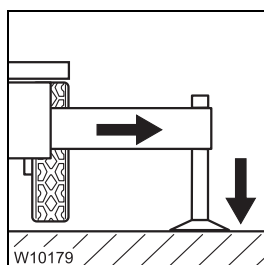

1. **If the truck crane is in the *Free on wheels* working position:**

Support the truck crane with the outrigger span required for unrigging according to the *Lifting capacity table* and raise until none of the wheels touches the ground; *Outriggers*, p. 13 - 25.

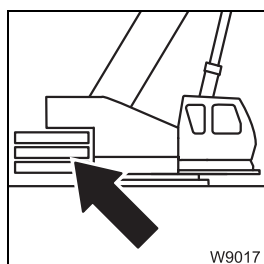

2. With the SLI adjusted accordingly, unrig the counterweight; *CHECKLIST: Unrigging counterweight*, p. 13 - 60.

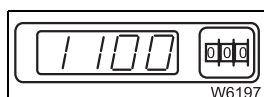

3. Enter the current rigging mode with the newly rigged counterweight version on the SLI; p. 12 - 21.



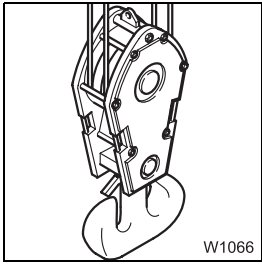

4. Depending on transport:

- Attach the hook block to the bumper; ■■■▶ p. 13 - 86 or
- Set down the hook block and unreeve the hoist rope;
 - ▶ *Hook block (setting down)*, p. 13 - 88,
 - ▶ *Hoist rope (unreeving)*, p. 13 - 95.

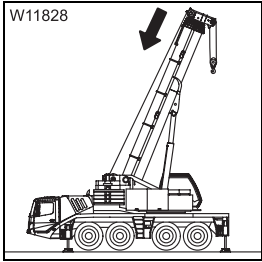

5. Retract the main boom, lock the telescopic sections and lock the telescoping cylinder to telescopic section I for on-road driving; ■■■▶ *Locking the telescopic section for on-road driving*, p. 12 - 79.

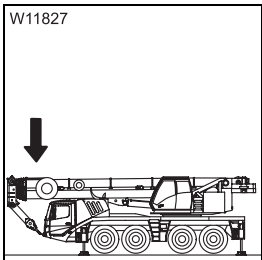

6. For on-road driving without trailer:

- Turn superstructure to the 180° position to the front with the SLI set accordingly,
- Place the main boom on the boom rest.

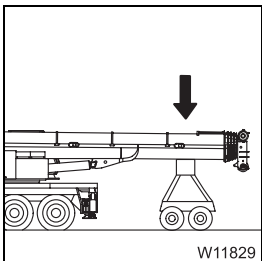

7. For on-road driving with a trailer:

- Set down the superstructure on a trailer with the SLI set accordingly and switch on the boom floating position; ■■■▶ p. 6 - 9,
- Switch on slewing gear freewheel; ■■■▶ p. 6 - 8,
- Switch on boom pre-tensioning if necessary; ■■■▶ p. 6 - 10,
- Switching off the houselock; ■■■▶ p. 12 - 14.

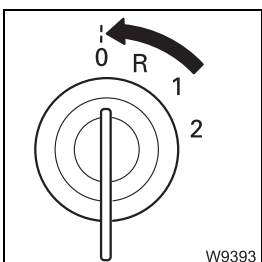

8. Turn off the engine for crane operation; ■■■▶ p. 11 - 19.

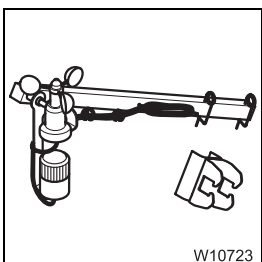

9. Remove anemometer and the air traffic control light; ■■■▶ p. 13 - 108.

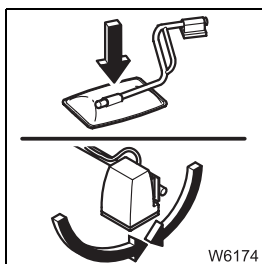

- 10.** Fold in all mirrors for crane operation; *Mirror for crane operation*, p. 13 - 114.

Lower the slewable spotlights; p. 12 - 100.

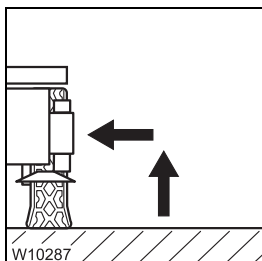

- 11.** Retract the outriggers; *CHECKLIST: Retracting the outriggers*, p. 13 - 27.

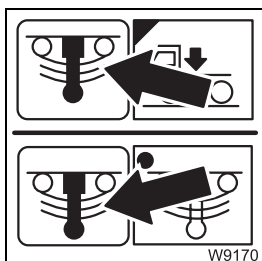

- 12.** Activate (unlock) the suspension.
The symbol must be **green** (suspension on); p. 5 - 15.

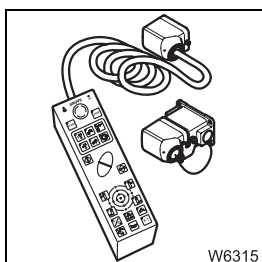

- 13.** Turn off the engine and, if necessary, remove the hand-held control and stow it away in the driver's cab; *Disconnecting the hand-held control*, p. 13 - 20.

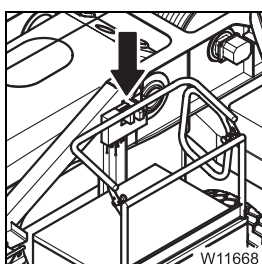

- 14.** Fold in the tread grid on the turntable; p. 13 - 113

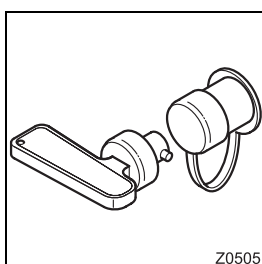

- 15.** When the truck crane is no longer being used; *Work breaks of more than 8 hours*, p. 12 - 122.





Blank page

41005067

13.2

Choosing a suitable site

Choose the position of your truck crane at the site with care. Observe the following points:

- Check whether that ground has sufficient load bearing capacity. You may need to enlarge the ground bearing area;  p. 13 - 9.
- Observe the required safe distances to slopes and pits;  p. 13 - 12.
- Earth the truck crane if there is a danger of it being charging with static electricity;  p. 13 - 13.
- Keep a safe distance to electrical lines;  p. 13 - 13.
- Choose the site so that unevenness of the ground can be compensated for by adjusting the outrigger cylinders. Maximum hoist of the outrigger cylinders;  p. 8 - 6.
- Choose a location where it is possible to keep the working radius to a minimum and where no obstacles are within the slewing range of the crane.

13.2.1

Determining the required ground bearing area

The stability of the truck crane depends primarily on the load bearing capacity of the ground. The load bearing capacity of the ground and the occurring outrigger pressure determine the ground bearing area required for the operation.

$$\text{surface area (m}^2\text{)} = \frac{\text{outrigger pressure (t)}}{\text{loadbearing capacity of the ground} \left(\frac{\text{t}}{\text{m}^2} \right)}$$

Outrigger pressure

- Determine the outrigger pressure for the operation planned using the *Outrigger pressure table*.



Load bearing capacity of the ground

- Determine the load bearing capacity of the ground using the table.

APPROXIMATE VALUES FOR THE LOAD BEARING CAPACITY OF THE GROUND		Load bearing capacity t/m ² (lbs/ft ²)
Backfilled, not artificially compacted ground:		0 to 10 (0 to 2 050)
Natural, apparently untouched ground:		
Mud, peat, marsh		0
Non-cohesive ground which is sufficiently firm:	Fine to medium sand	15 (3 070)
	Coarse sand to gravel	20 (4 100)
Cohesive ground:	Mushy	0
	Soft	4 (820)
	Stiff	10 (2 050)
	Semi-solid	20 (4 100)
	Hard	40 (8 200)
Rock with minimal fissures in sound, unweathered condition and with favourable strata:	In closed bed sequence	150 (30 700)
	In massive or columnar formation	300 (61 400)



If you are unsure about the load bearing capacity of the ground, please have the ground tested.

Ground bearing area

- Now calculate the required ground bearing area.
- Check that the surface of the outrigger pad (▮▮▮▶ p. 8 - 6) is larger than the calculated ground bearing area. If the surface of the outrigger pad is smaller, you will need to enlarge the ground bearing area.



Danger of overturning if the ground bearing area is too small!

Ensure that the actual ground bearing area is at least as large as specified in the table.

This prevents the ground from giving way and the truck crane from overturning.

Example for calculating the required ground bearing area:

If the outrigger pressure is 25 t and the ground has a bearing capacity of 40 t/m², then the required ground bearing area for this supporting cylinder is 0.625 m² (= 6 250 cm²).

If the outrigger pad has a surface of 2 000 cm², you would need to enlarge the ground bearing area by packing the outrigger pads; ▮▮▮▶ p. 13 - 39.

41005061

13.2.2

Safe distance from slopes and pits

Erect the crane at a safe distance from slopes and pits. The distance also depends on the type of ground if the slopes and pits are not supported.

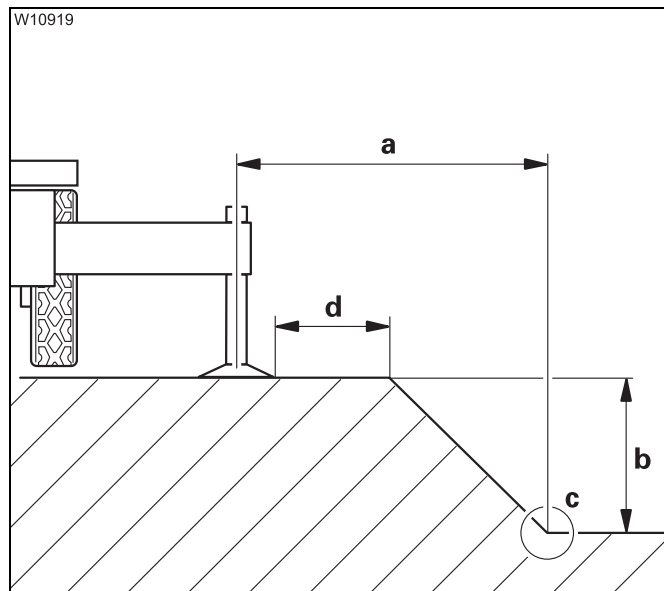

Rule of thumb:

With *loose or backfilled* ground, the safe distance (**a**) must be twice the depth of the pit (**b**).

$$a = 2 \times b$$

With *vegetated, cohesive* ground, the safe distance (**a**) must equal the depth of the pit (**b**).

$$a = 1 \times b$$

The safe distance is measured from the base of the pit (**c**).

In addition to this the safe distance (**d**) between the pads and the pit border must always be more than 2.00 m (6.6 ft).

410050061

13.2.3

Earthing the truck crane

The truck crane may become charged with static electricity. This may occur especially when using outrigger pads made of plastic or when the outrigger pads are packed with insulating material (e.g. wooden planks).

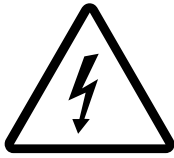

Risk of accidents due to electric shock

Earth the truck crane before you start to work with it

- Near strong transmitters (radio transmitters, radio stations, etc.)
- Near high-frequency switching stations
- If a thunder storm is forecast

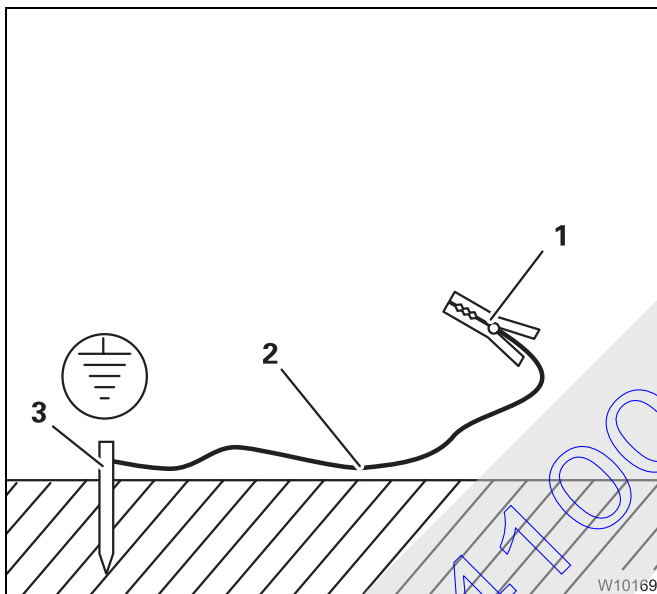

Use electrically conducting material for earthing.

- Hammer a metal rod (3) (length of approx. 2.0 m (6.6 ft)) at least 1.5 m (5 ft) into the ground.
- Moisten the soil around the metal rod (3) for better conductivity.
- Clamp an insulated cable (2) to the metal rod (3) (cross-section of at least 16 mm² (0.025 inches²)).
- Connect the free end of the cable with a clamp (1).

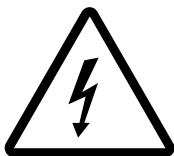

Risk of accidents due to electric shock

Ensure that the connections between the cable and the clamp are electrically conductive.

Do not attach the clamp to parts that are screwed on, such as valves, covers or similar parts.

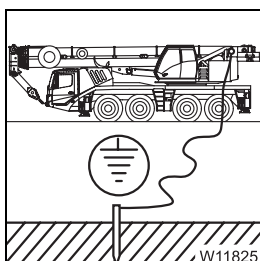

- Attach the clamp to the main boom or to the superstructure.

13.2.4

Safe distance from electrical lines

Always observe the respective national regulations when working in the vicinity of electrical lines.



Risk of accidents due to electric shock

This truck crane is not insulated.

If the truck crane, its equipment, its load / lifting tackle or the guide ropes touch an electric cable, this will cause serious injury or even death.

- If there are electric cables in the working range of the truck crane, have these cables disconnected from the source of power, if possible.

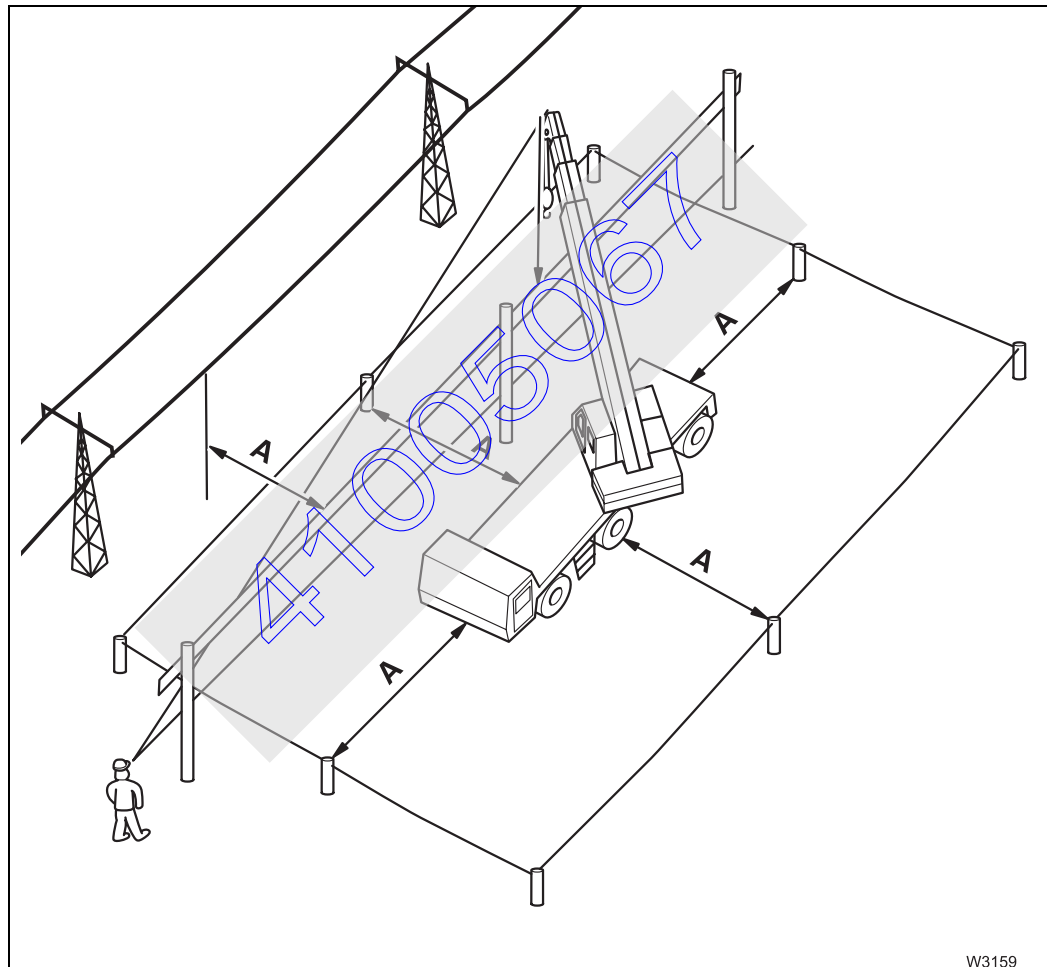

If this is not possible, you must at least observe the prescribed safe distance (**A**).

Different safe distances are recommended by the respective national regulations:

For example, according to DIN VDE 0150

Voltage	Safe distance (A)
up to 1,000 V	1 m (3.3 ft)
from 1,000 V to 110 000 V	3 m (9.8 ft)
from 110,000 V to 220,000 V	4 m (13.1 ft)
from 220,000 V to 380,000 V	5 m (16.4 ft)

For example as per ASME B 30.5 (USA)

Voltage	Safe distance (A)
up to 50,000 V	3.05 m (10 ft)
from 50,000 V to 200,000 V	4.60 m (15 ft)
from 200,000 V to 350,000 V	6.10 m (20 ft)
from 350,000 V to 500 000 V	7.62 m (25 ft)
from 500,000 V to 750,000 V	10.67 m (35 ft)
from 750,000 V to 1,000,000 V	13.72 m (45 ft)

- Erect an obstacle at a minimum safe distance (A) from the electric cable which will keep the equipment of the truck crane and load / lifting tackle away from the cable. Account for possible swaying of the load or the cable.
- Cordon off the area around the truck crane at the safe distance (A). That way the safety area is enlarged in case the cable is touched.
- Have banksmen in visual or radio contact with you check that you are observing the safe distance (A)
- Only use guide ropes of non-conductive material if the load has to be guided.

If you have touched the electric cable:

- Keep calm
- Do not leave the crane cab.
- Tell anyone standing outside not to touch the crane, the load or the lifting tackle.
- Move the main boom out of the danger area.

Blank page

41005067

13.3

Rigging work after driving with a trailer

If the main boom was resting on a trailer (dolly) while driving the truck crane, you must perform the following before working with the crane:

- Switch off the slewing gear freewheel; ▮▮▮▮ p. 13 - 18,
- Switch off the boom floating position; ▮▮▮▮ p. 13 - 17,
- Switch off boom pre-tensioning, if necessary; ▮▮▮▮ p. 13 - 19.

13.3.1

Switching off the boom floating position

You must switch off the boom floating position before you raise the main boom off the trailer.



Risk of accidents due to the main boom falling down

Always secure the lever with the padlock after switching off the boom floating position.

This prevents the raised main boom from falling down when actuating the lever.

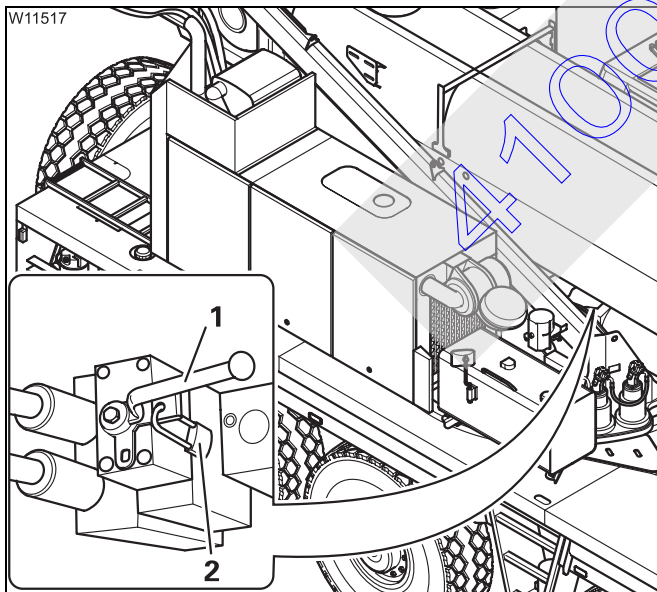

- Remove the padlock (2)
- Switch the valve I over – lever (1) positioned vertically pointing outwards or inwards, depending on its fitting position.
- Secure the lever (1) with the padlock (2)

The boom floating position is now switched off.

13.3.2

Switching off the slewing gear freewheel

If the slewing gear freewheel is switched on, switch it off prior to working with the crane.



Risk of accidents with the slewing gear freewheel switched on

Switch off the slewing gear freewheel before working with the crane.

If it is not switched off, the slewing gear brake does not work and you cannot stop slewing movements in time.

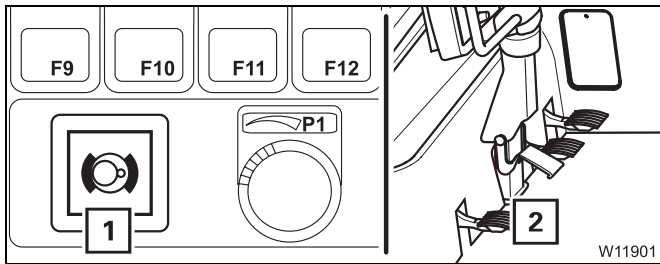

Prerequisites

- The engine for crane operation is running
- The slewing gear is switched on – the lamp (1) has gone out; see p. 12 - 88.
- The pedal (2) is **not** actuated.

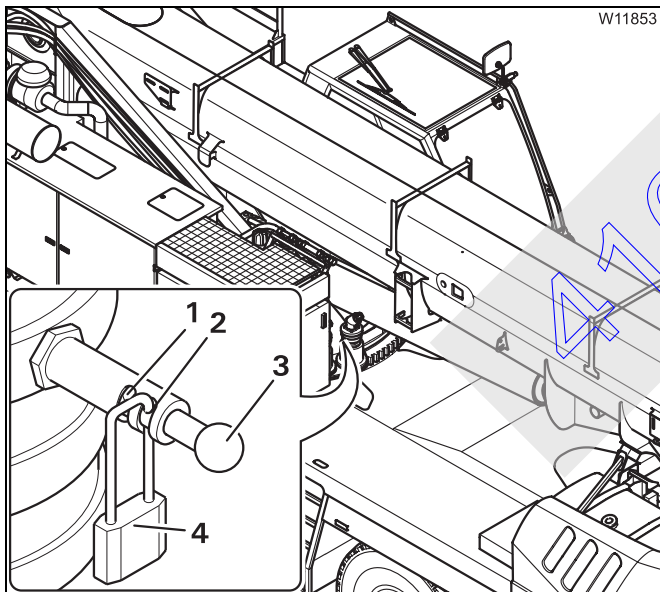

- Remove the lock (4) from the bore (1).
- Pull the pin (3) out as far as possible.
- Secure the pin with the lock in the bore (2) and remove the key.

Now the slewing gear freewheel is switched off and secured.

- Switch off the slewing gear freewheel on all slewing gears in the same way.

Before slewing

Support the truck crane with the necessary outrigger span, enter the corresponding SLI code and derrick the main boom to an angle permissible within the working range.

13.3.3

Switching off boom pre-tensioning

You must switch off the boom pre-tensioning before you raise the main boom off the trailer.

To switch off boom pre-tensioning, you must bring the valves I to IV into the required positions, which will empty the pressure accumulator.



Danger of the hydraulic oil overheating

Always switch the valve IV over (lever in horizontal position) before operating the crane.

This prevents the pressure in the hydraulic circuit from rising and the hydraulic oil from exceeding the permissible temperature of 80 °C (176 °F).

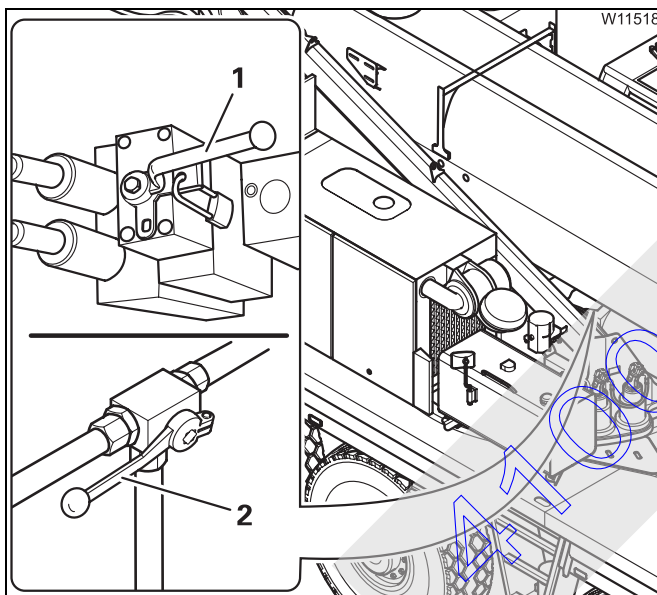

Valve I (1) is in the correct position if the boom floating position is switched off; see p. 13 - 17.

- Switch valve IV over – lever (2) in horizontal position.

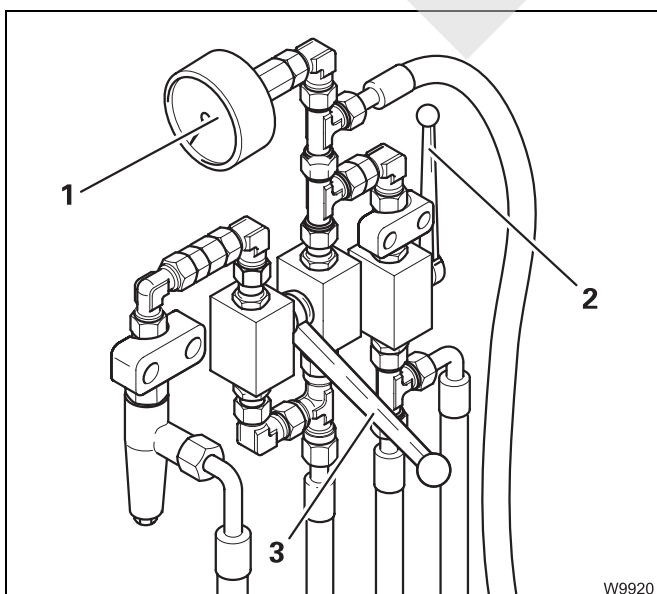

The valves II and III are under the pressure gauge (1).

- Open valve II – the lever (2) is vertical.

The pressure accumulator is emptied. The pressure on the pressure gauge (1) must drop to 0 bar (0 psi).

Valve II stays closed – the lever (3) points downwards.

13.4

Connecting / disconnecting the hand-held control



Switch off the engine for driving and crane operation. Pulling a bridging plug will make the engines go out, but this action is only designed for emergencies.

The ignition can be switched on or off.

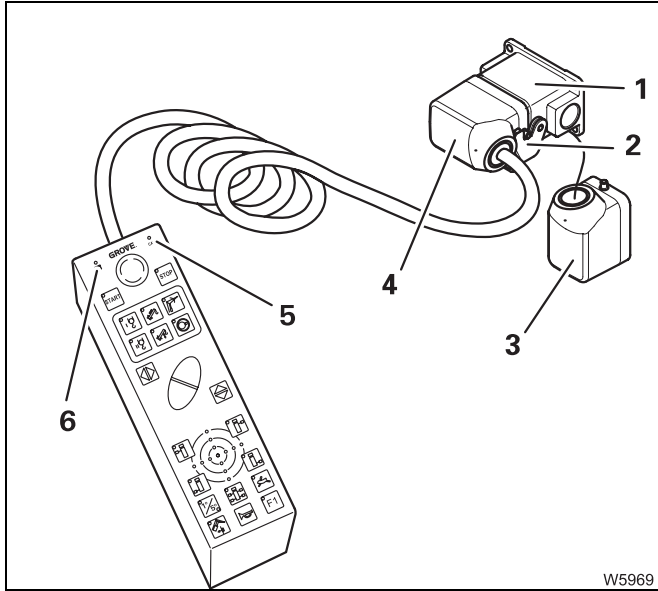

To connect the hand-held control

- Open the cap (2) and pull the bridging plug (3) out of the socket (1).
- Insert the plug (4) into the socket (1) and secure it with the cap (2.)
- After about 20 seconds, the lamps (5) and (6) light up – the ignition is switched on.

There is a malfunction if the lamp (5) does not go on or flashes: ► p. 15 - 22.



Danger due to unauthorised use

Always stow the hand-held control in the driver's cab or in the crane cab before you leave the crane, and lock the doors.

That way you can prevent unauthorised persons from starting the engine.

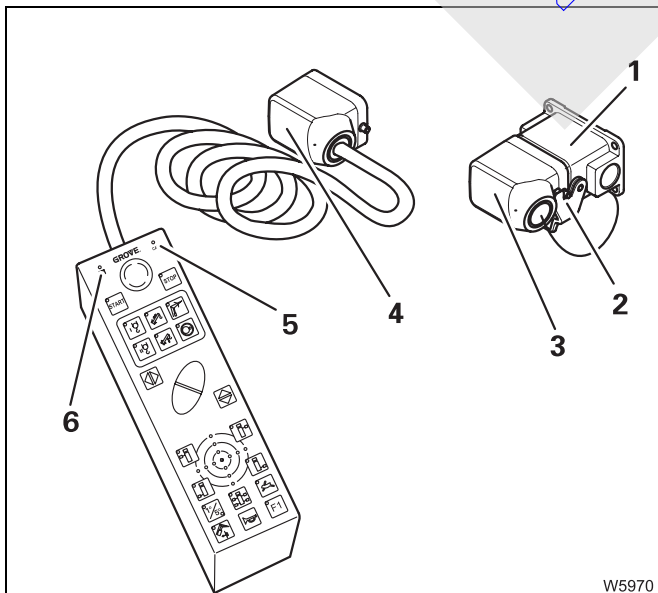

Disconnecting the hand-held control

- Open the cap (2).
- Pull the plug (4) out of the socket (1) – the lamps (5) and (6) go out.
- Insert the bridging plug (3) into the socket (1) and secure it with the cap (2.)

The ignition is turned off, unless it is switched on at an ignition lock.

13.5

Starting the engine for driving for rigging work

For rigging work, the engine for driving must be running, e.g. to move the outriggers. You can start the engine for driving:

- With the hand-held control
- From the crane cab



You can generally only start the engine if a bridging plug is inserted in all sockets which are not required.

13.5.1

Starting / turning off the engine with the hand-held control

Prerequisites

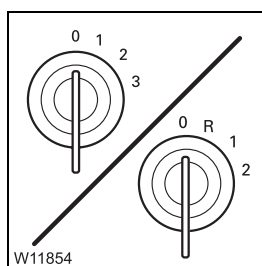

The following requirements must be met before you can start the engine for driving with the hand-held control:

- The ignition is switched off in the crane cab.
- The ignition is switched off in the driver's cab.

- Connect the hand-held control to a socket on the carrier; p. 13 - 20.



If you connect the hand-held control to a carrier socket while the engine for crane operation is running, that engine will go out. In that case you cannot start the engine for driving since the ignition in the crane cab is still switched on.



To start the engine

All activities and inspections required to start the engine must be carried out before starting the engine; ||||▶ p. 4 - 1.

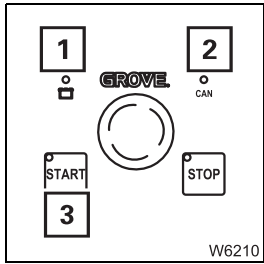

- Wait until the lamps (2) and (1) light up.

There is a malfunction if the lamp (2) does not go on or flash after about 20 seconds; ||||▶ p. 15 - 22.

- Press the button (3) once – the engine starts

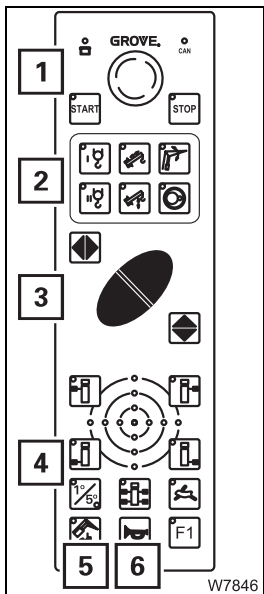

The following buttons are now active on the hand-held control:

- All buttons on the control panel (1).
- The function buttons (3).
- All buttons on the control panel (4).
- The button (6) for the horn on the carrier.

The button (2) and button (5) are inactive.

The *Outriggers* control units are locked after connection of the hand-held control.



You can start the engine from the crane cab, but the operating elements for crane operation are disabled after starting the vehicle engine with the hand-held control.

Turning off the engine

You cannot turn off the engine with the ignition lock in the driver's cab if it was started with the hand-held control.



- Press the button (1) once – the engine goes off.

13.5.2

Starting / turning off the engine from the crane cab

Prerequisites

The following requirements must be met before you can start the engine for driving from the driver's cab:

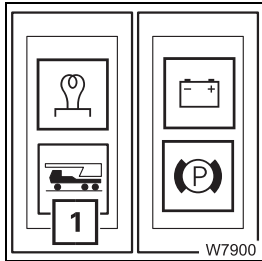

- The hand-held control has been disconnected and bridging plugs have been plugged into all superstructure and carrier sockets.
- The carrier ignition is switched off and the ignition key is removed. The lamp (1) in the crane cab has gone out.
- The superstructure ignition has been switched on for approx. 30 min.

The engine for crane operation can be switched on or off.

To start the engine

All activities and inspections required to start the engine must be carried out before starting the engine; p. 4 - 1.



If you wish to start the engine for driving from the crane cab; p. 14 - 8.

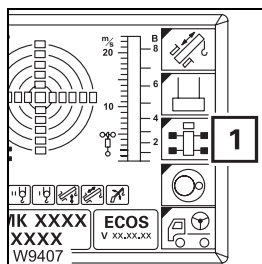

- If necessary, open the main menu and press the button (1) once. The *Outriggers* submenu opens.

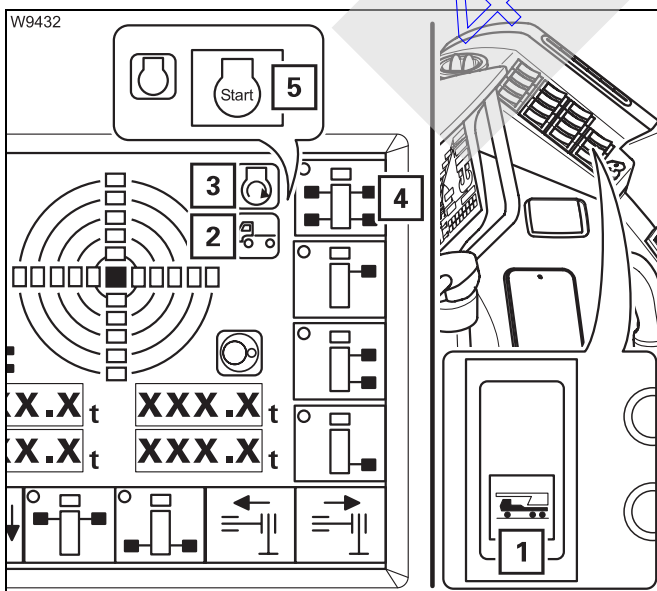

- Press the button (1) **down** once.
The carrier ignition is turned on:
 - The indicator lamp in the button (1) flashes.
 - The symbol (2) turns **green**.
- Press the button (5) once. The engine starts.
When the engine is running
 - The symbols (3) and (4) are displayed.
 - The lamp in the button (1) lights up.



After starting the engine

The engine runs at idling speed. The engine speed cannot be changed. You can operate the functions from the crane cab in the *Outriggers* submenu;  p. 13 - 36.

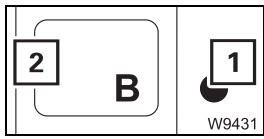

In the event of a warning message on the carrier, the lamp (1) flashes.

- Press the button (2) once.

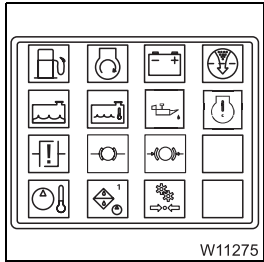

The *Warning* submenu (carrier) opens. The corresponding symbol is **red**;  p. 12 - 102.

Turning off the engine

You can turn off the engine from the crane cab or using any of the emergency stop switches on the superstructure or the carrier.

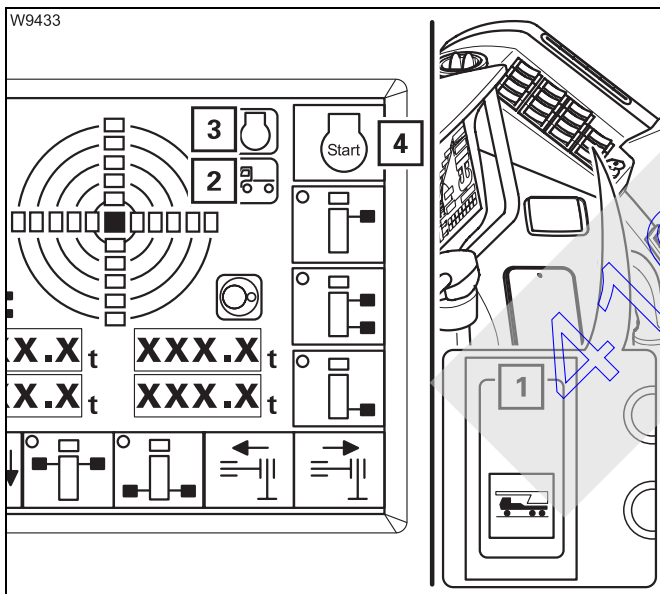

- Press the button (1) **up** once.

The carrier ignition is turned off and the engine is switched off.

The lamp in the button (1) goes out.

The symbol (2) turns **red**.

The symbols (3) and (4) are displayed.

13.6

Outriggers



Danger of crushing from extending outrigger beams

You may only activate the outriggers if you yourself or a banksman, with whom you are in visual contact, have an unobstructed view of their movements.

13.6.1

CHECKLIST: Extending the outriggers



This checklist is not a complete set of operating instructions. There are accompanying operating instructions which are referred to by cross-references.

Observe the warnings and safety instructions specified there.

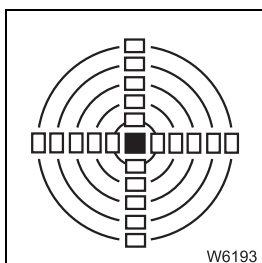

1. Level the truck crane with the level adjustment system and lower it as far as possible; p. 5 - 65.

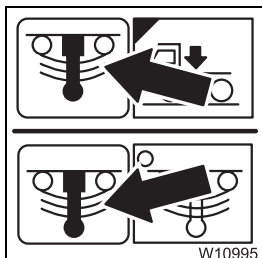

2. Deactivate (lock) the suspension.
The symbol must be **red** (suspension off); p. 5 - 15.

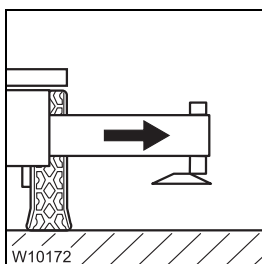

3. Extend all outriggers to the required span;
 - Permissible outrigger spans*, p. 13 - 28,
 - Setting the spans*, p. 13 - 30
 - Extending / retracting outriggers*, p. 13 - 32.

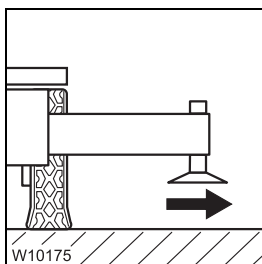

4. Move the outrigger pads into working position and secure them; p. 13 - 38.



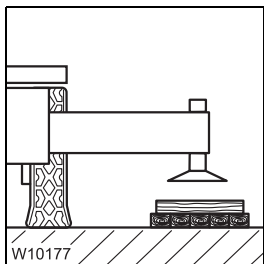

5. Enlarge the ground bearing area if necessary;
 ▣▣▣▣▶ *Determining the required ground bearing area, p. 13 - 9,*
 ▣▣▣▣▶ *Enlarging the ground bearing area, p. 13 - 39.*

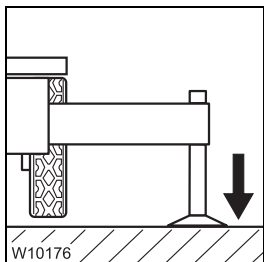

6. Extend the supporting cylinders until none of the wheels are touching the ground; ▣▣▣▣▶ p. 13 - 41.

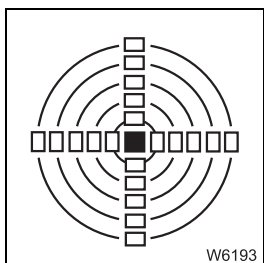

7. Level the truck crane with the outriggers; ▣▣▣▣▶ p. 13 - 46.

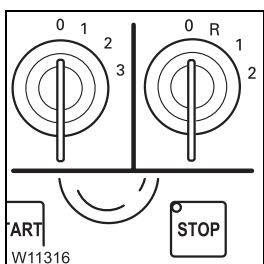

8. Turn off the engine
– After operating it with the hand-held control; ▣▣▣▣▶ p. 13 - 22,
– After operating it from the control units; ▣▣▣▣▶ p. 4 - 21,
– After operating it from the crane cab; ▣▣▣▣▶ p. 13 - 24.

13.6.2

CHECKLIST: Retracting the outriggers



This checklist is not a complete set of operating instructions. There are accompanying operating instructions which are referred to by cross-references.

Observe the warnings and safety instructions specified there.

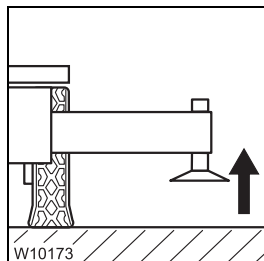

1. Retract the outrigger cylinders as far as possible; p. 13 - 41.

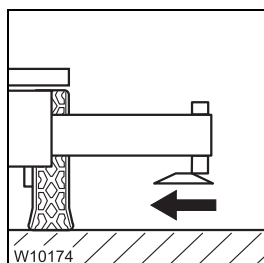

2. Move the outrigger pads into driving position and secure them; *Moving them into driving position*, p. 13 - 38.

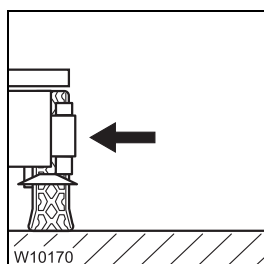

3. Fully retract and secure all outrigger beams;
 - Permissible outrigger spans*, p. 13 - 28,
 - For on-road driving*, p. 13 - 31,
 - Extending / retracting outriggers*, p. 13 - 32.

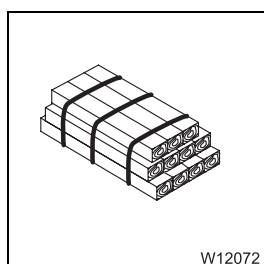

4. Stow away packing material safely, if applicable.

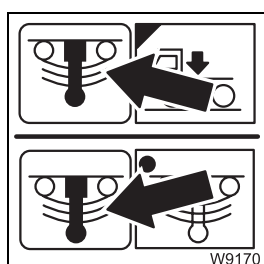

5. Activate (unlock) the suspension.
The symbol must be **green** (suspension on); p. 5 - 15.



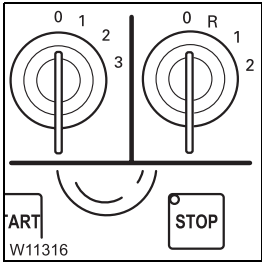

6. Turn off the engine

- After operating it from the control units; ▮▮▮ p. 4 - 21.
- After operating it from the crane cab or using the hand-held control; ▮▮▮ p. 11 - 19.

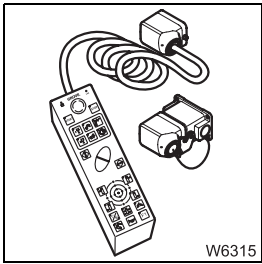

7. If necessary, disconnect the hand-held control and stow it away;
▮▮▮ p. 13 - 20.

13.6.3 Permissible outrigger spans



Risk of overturning when slewing the superstructure

With some outrigger spans, slewing is only permissible with certain counterweight versions and boom positions; ▮▮▮ *Slewing with rigged counterweight*, p. 13 - 82.

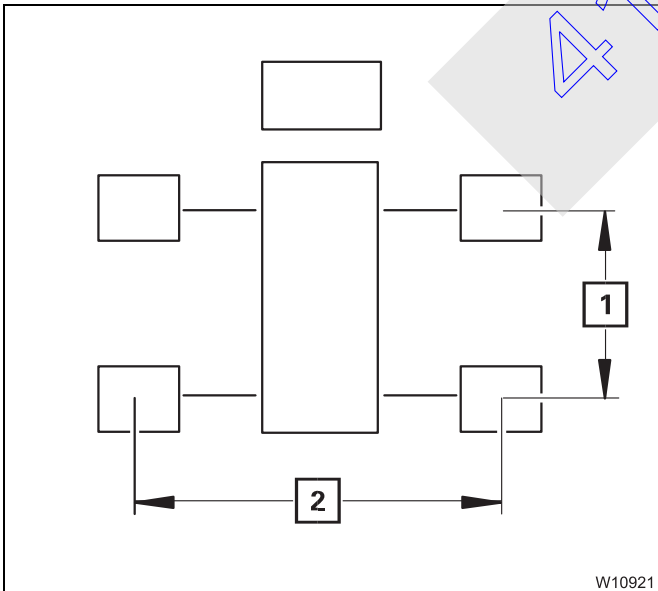

The *Lifting capacity table* specifies the permissible outrigger spans in metres x metres (feet x feet):

- 8.332 x 7.00 m (27.3 x 23.0 ft)
- 8.332 x 6.00 m (27.3 x 19.6 ft)
- 8.332 x 5.00 m (27.3 x 16.4 ft)
- 8.332 x 4.00 m (27.3 x 13.2 ft)
- 8.332 x 2.54 m (27.3 x 8.4 ft)

The first value represents the outrigger length (1), e.g. 8.332 m (27.3 ft).

The second value specifies the required outrigger span (2), e.g. 7.00 m (23.0 ft).

In addition, there is a lifting capacity table for the *Free on wheels* work position.

13.6.4

Preparing the truck crane

In the driver's cab

Levelling the truck crane

- Level the truck crane with the level adjustment system; *Operation of the level adjustment system*, p. 5 - 65.

Locking the suspension

- Switch off the suspension; p. 5 - 14.

The control elements for the outriggers are only released if the suspension is deactivated. If the suspension is switched off, the wheels are lifted when the crane is put on outriggers.

Control units (outrigger)

You can switch the *Outrigger* control units on and off from the crane cab.

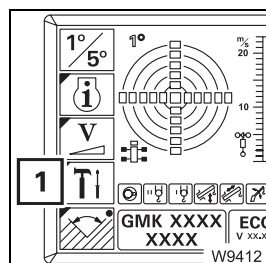

- If necessary, open the main menu and press the button (1) once.

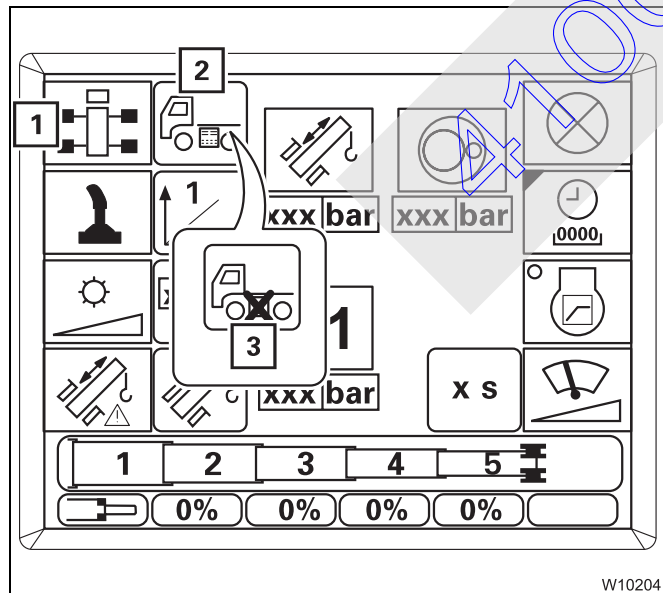

The *Settings* submenu opens.

The current status is displayed:

- Symbol (2) – operating units on, buttons enabled
- Symbol (3) – operating units off, buttons disabled
- To switch on or off, press the button next to the symbol (1) once.

13.6.5

Setting the spans

Only extend the outrigger beams to the permissible span.



Danger of overturning if the outrigger beams are not correctly extended

Always extend **all** outrigger beams to the required outrigger span even if you are only working on one side. Otherwise the rear stability for the rigging mode according to the SLI code is no longer guaranteed.



This section describes how to release and secure the outriggers, as well as the markers for the outrigger spans.

There are various ways to operate the outrigger beams; *Extending / retracting outriggers*, p. 13 - 32.

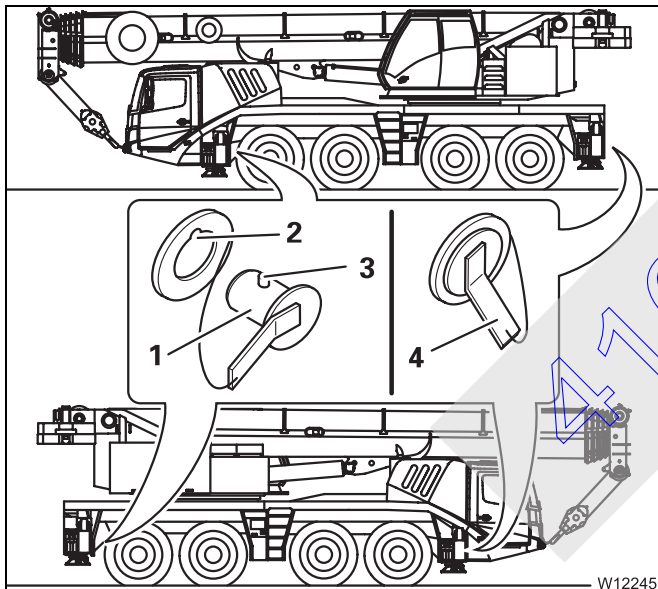

Releasing the outriggers

- Turn the pin (1) to the side and pull it out.

Securing the outriggers

- Plug the pin with the peg (1) with the peg (2) through the cutout (3).
- Turn the pin in such a way that the handle (4) points downwards.

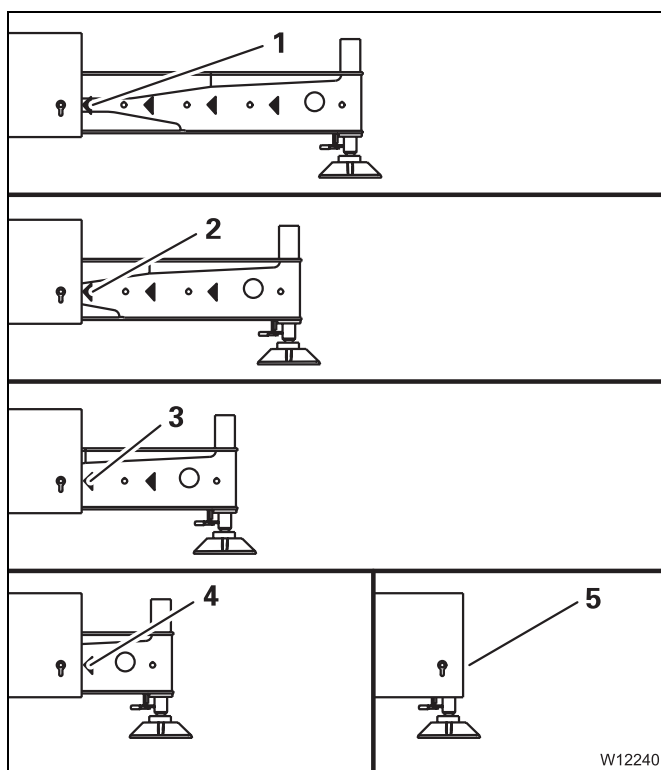

Setting the spans

- Release the outriggers.
- Extend or retract the outriggers up to the marker for the required outrigger span.
 - 1 8.332 x 7.00 m (27.3 x 23.0 ft)
 - 2 8.332 x 6.00 m (27.3 x 19.6 ft)
 - 3 8.332 x 5.00 m (27.3 x 16.4 ft)
 - 4 8.332 x 4.00 m (27.3 x 13.2 ft)
 - 5 8.332 x 2.54 m (27.3 x 8.4 ft)

No marker, retract fully
- Secure the outrigger.
- Set the outrigger span on the other outriggers in the same way.

For on-road driving

- Create the outrigger span 8.332 x 2.54 m (27.3 x 8.3 ft) for all outriggers and secure all outriggers.
- Bring all the outrigger pads into driving position; ►► p. 13 - 38.



Danger of accidents due to outrigger beams moving out

Completely retract all outriggers and secure them. This prevents the outrigger beams from swaying out in curves and causing serious accidents.

13.6.6

Extending / retracting outriggers



Risk of accidents if supporting cylinders cannot be seen!

Cordon off the area where you intend to extend and retract the outrigger beams. Nobody is allowed to be in this area.

Observe the moving outrigger cylinders or have them observed by a banksman who is in visual contact with you.



Danger of overturning if improperly supported

Always extend **all** the outrigger beams, and always extend them to the spans corresponding to the SLI code.

This also applies if you are working on one side only, since it ensures that the truck crane is stable at the rear.



Risk of damage to the outriggers

Before extending the outrigger beams, always check whether they have been released.

- Check that the outriggers are released; ■■■▶ p. 13 - 30.

Depending on the rigging, control elements are provided for moving the outriggers

- On the *Outriggers* control units; ■■■▶ p. 13 - 36
- On the hand-held control; ■■■▶ p. 13 - 34
- In the crane cab; ■■■▶ p. 13 - 36

From the control units

If the hand-held control is connected, the *Outriggers* operating units are inactive.

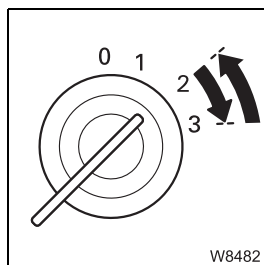

To start the engine

- Remove the hand-held control if necessary, and start the engine from the driver's cab; p. 4 - 13.

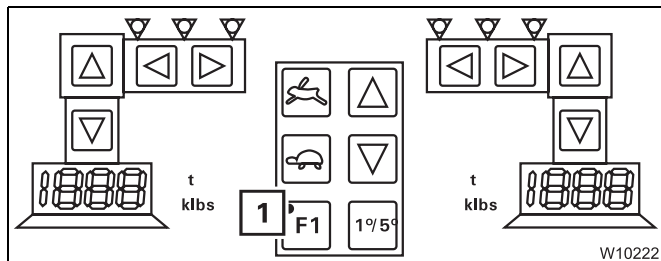

Switching on the lighting

Only the lamp (1) lights up after opening the door.

- Press any button.
The lights are switched on.

Moving the outriggers



You can only operate the outriggers to the left and right of the operating unit on the operator's side.

- Observe the safety instructions for operating the outriggers; p. 13 - 32.

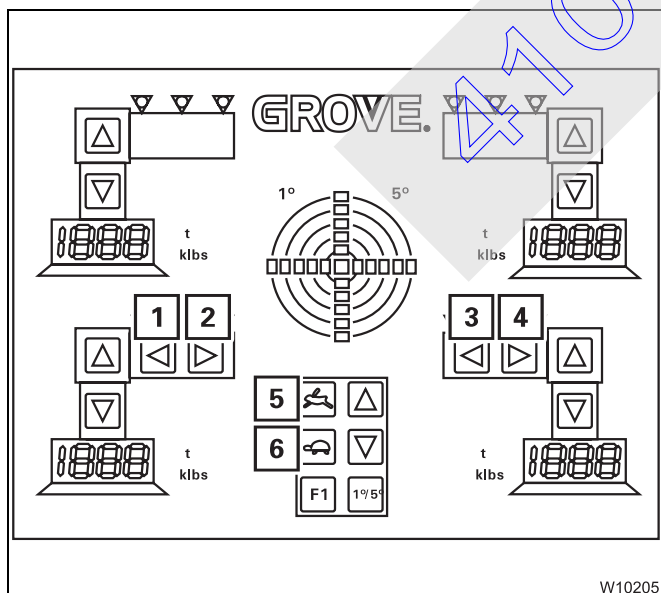

- Press the button
 - 5 for high-speed mode or
 - 6 for normal speed.
- Additionally press the button for the desired outrigger.
 - 1 Extend left
 - 2 Retract left
 - 3 Retract right
 - 4 Extend right
 - 1 + 4 Extend both
 - 2 + 3 Retract both

The outriggers move until you let go of the respective button or until the respective end position has been reached.



With the hand-held control

The hand-held control needs to be connected to the carrier.

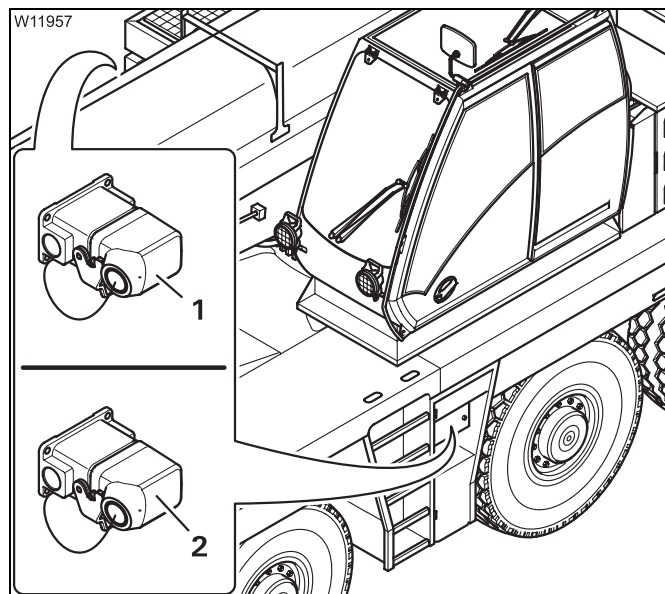

- Connect the hand-held control to the required socket (1) or (2).

- 1 For the right-hand outrigger
- 2 For the left-hand outrigger

Information on connecting;  To connect the hand-held control, p. 13 - 20.

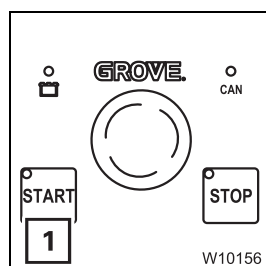

To start the engine

- Press the button (1) – the engine starts;  p. 11 - 17.

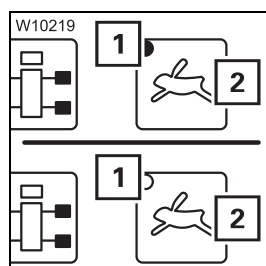

Pre-select high-speed mode / normal speed

- Press the button (2).
 - Lamp (1) lights up – high-speed mode pre-selected,
 - Lamp (1) goes out – normal speed pre-selected.

Pre-select outriggers



You can only pre-select outriggers on the side to which the hand-held control is connected.

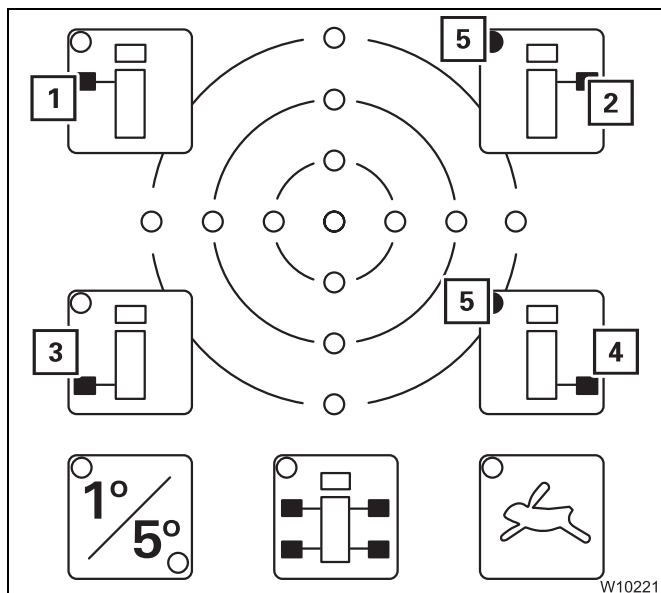

- Press the button for the required outrigger once.

- 1 Front left
- 2 Front right
- 3 Rear left
- 4 Rear right

- 1 + 3 Both on left
- 2 + 4 Both on right

Pre-selection is switched on and the lamp in the corresponding button lights up, e.g. the lamps (5).

After about 10 seconds the pre-selection is switched off.

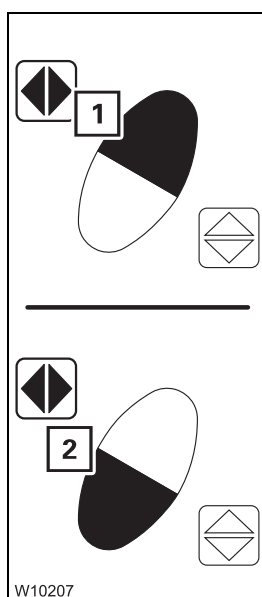

Extending / retracting outriggers

- Observe the safety instructions for operating the outriggers;
 - ▮▮▮ p. 13 - 32
- Press the button combination for the desired movement:
 - 1 Extend
 - 2 Retract

The pre-selected supporting cylinders move until you let go of the respective button or until the respective end position has been reached.



From the crane cab

The following operating elements are in the *Outriggers* submenu.

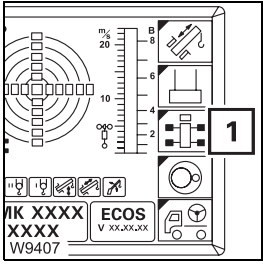

Opening the submenu

- If necessary, open the main menu and press the button (1) once.

The *Outriggers* submenu opens.

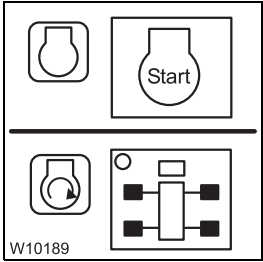

To start the engine

- Switch the carrier ignition on and start the engine for driving; p. 13 - 23.
- Switch off the slewing gear

Pre-select outriggers



Only pre-select one outrigger. If you pre-select several outriggers, operation of the outrigger beams is not released.

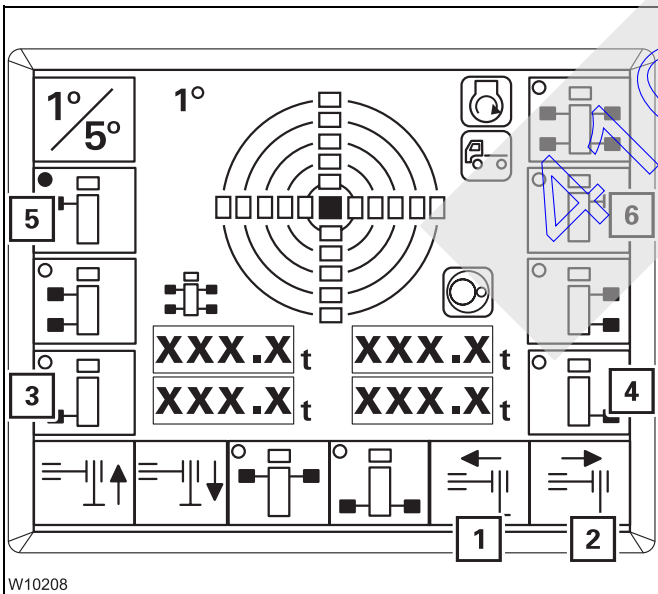

- Press the button once next to the symbol for the desired outrigger:

- 3 Rear left
- 4 Rear right
- 5 Front left
- 6 Front right

Pre-selection is switched on.

- The dot in the symbol turns **green**, e.g. in symbol (5).

- The symbols (1) and (2) turn **black**.

After about 10 seconds the pre-selection is switched off.

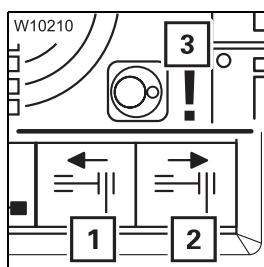

If the symbol (3) appears, this means that the slewing gear is switched on – the symbols (1) and (2) remain grey.

- Switch off the slewing gear

Extending / retracting outriggers

- Observe the safety instructions for operating the outriggers;
 ▶ p. 13 - 32.

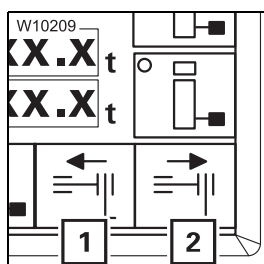

- Press the button below the symbol for the desired movement:

- 1 Retract
- 2 Extend

The pre-selected outrigger beams move until you let go of the respective button or until the respective end position has been reached.

41005067

13.6.7

Moving the outrigger pads into working / driving position

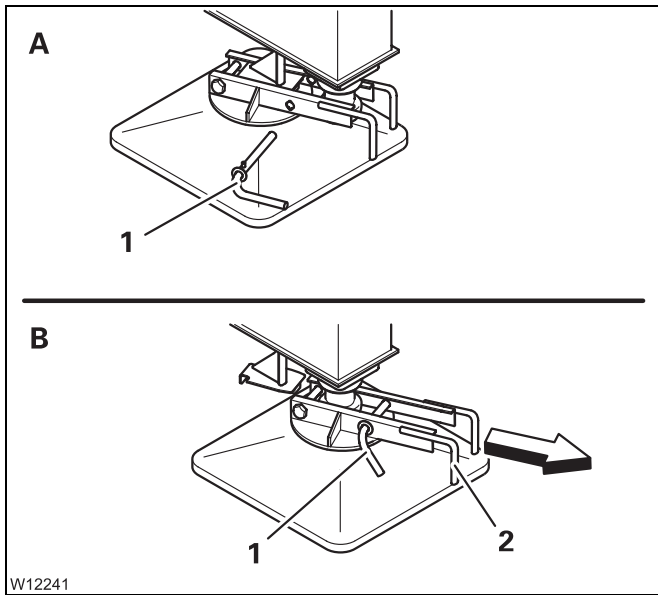

Moving them into working position

- (A) – Pull out the pin (1).
- (B) – Pull the outrigger pad outwards by the handle (2).
- Secure the outrigger pad with the pin (1).
- Secure the pin (1).
- Move the other outrigger pads into working position in the same way.

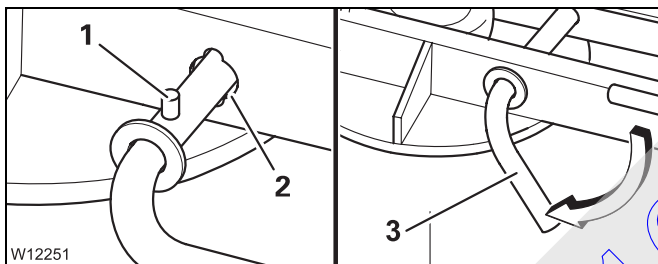

Secure the pin

- Plug the pin with the peg (1) through the cut-out (2).
- Turn the grip (3) downwards.

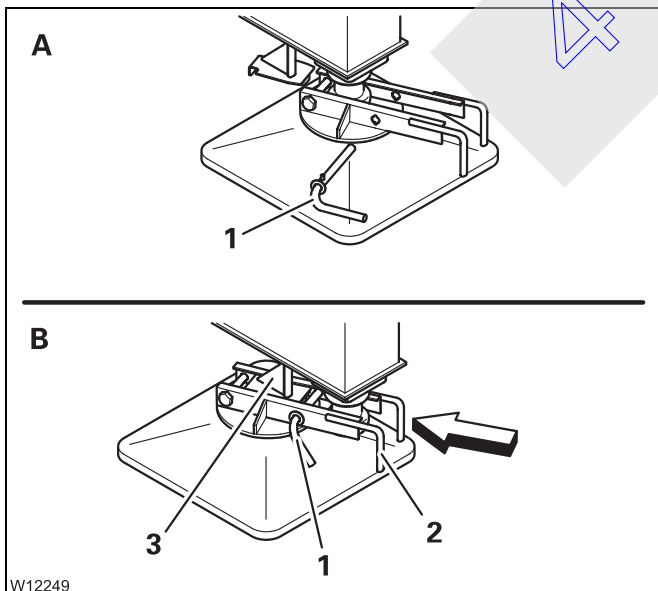

Moving them into driving position

- (A) – Pull out the pin (1).
- (B) – Pull the outrigger pad by the handle (2) onto the holder (3).
- Secure the outrigger pad with the pin (1).
- Secure the pin (1).
- Move the other outrigger pads into driving position in the same way.

13.6.8

Enlarging the ground bearing area

If the surface of the outrigger pads is too small, you must enlarge the ground bearing area by packing the outrigger pads;  *Determining the required ground bearing area*, p. 13 - 9.

For packing, only use suitable materials that will withstand the outrigger pressure, e.g. straight hardwood of similar cross-sections or steel plates with welded-on strips that will keep the outrigger pads in position.



Risk of accidents if the packing is insufficient

Only use materials of sufficient strength.

This will prevent the packing from giving way and causing the truck crane to tilt and overturn.



Danger of overturning if the packing or truck crane is at an angle

Level the truck crane and the packing.

This prevents the outrigger pads from slipping off the inclined packing and causing the truck to overturn.

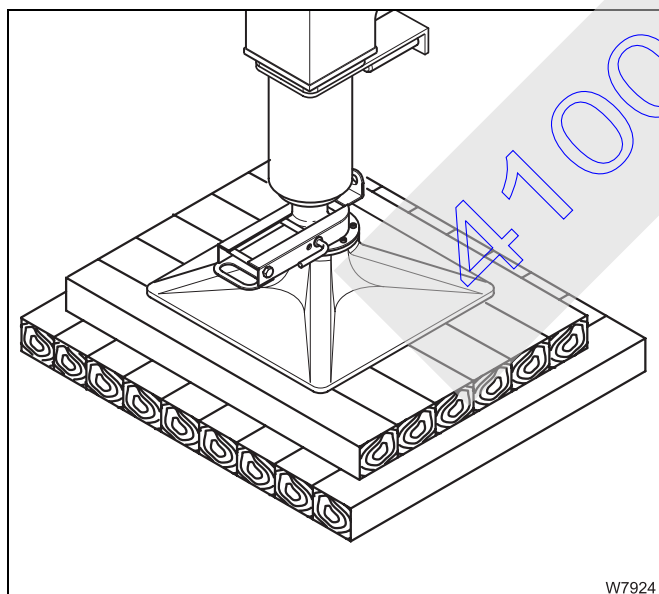

Level the packing; the outrigger pad must not be at an angle.

Ensure that the outrigger pressure is evenly distributed over the packing:

- The outrigger pad must be positioned in the centre of the packing.
- The outrigger pad must cover all the wooden planks.
- If the packing has several layers, each layer must be placed below the other offset by 90°.

Consult your supervisor if you are in doubt.

W7924

Blank page

41005067

13.6.9

Extending / retracting supporting cylinders



Danger of overturning due to insufficient load bearing capacity of the ground

Enlarge the ground bearing area if the ground cannot withstand the resulting outrigger pressure.

This prevents the ground under the outrigger pad from giving way and causing the truck crane to tilt and overturn.



Risk of accidents if supporting cylinders cannot be observed

Nobody is allowed to be in the area of the supporting cylinders.

Observe the moving supporting cylinders or have them observed by a banksman who is in visual contact with you.



Risk of damage to the supporting cylinders

Move the outriggers as uniformly as possible on all four support points.

This prevents the supporting cylinders from getting damaged due to one-sided pressure.



Risk of damage to the tyres



Before retracting the supporting cylinders, remove any sharp-edged and pointed materials from below the tyres.

This keeps the tyres from being punctured or damaged when the truck crane is lowered.



Do not extend the supporting cylinders as far as possible. The supporting cylinders must have a remaining stroke of at least 25 mm (1 in) in order to carry out alignment corrections.

There are various operating elements to operate the outriggers

- On the *Outriggers* control units;  p. 13 - 42
- On the hand-held control;  p. 13 - 43
- In the crane cab;  p. 13 - 44



From the control units

If the hand-held control is connected, the *Outriggers* operating units are inactive.

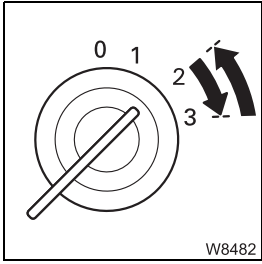

To start the engine

- Remove the hand-held control if necessary, and start the engine from the driver's cab; p. 4 - 13.

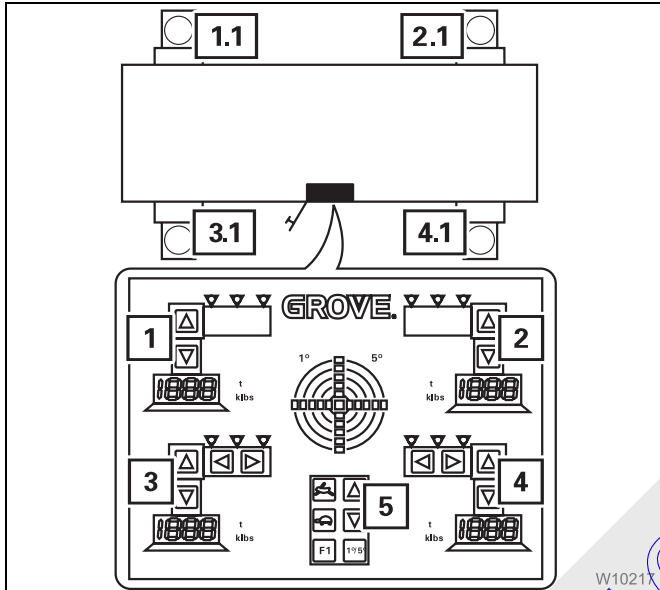

Moving the supporting cylinders

Assignment of buttons:

- 1 Supporting cylinder 1.1
- 2 Supporting cylinder 2.1
- 3 Supporting cylinder 3.1
- 4 Supporting cylinder 4.1
- 5 All supporting cylinders (1.1) to (4.1)

- Observe the safety instructions for operating the supporting cylinders; p. 13 - 41.

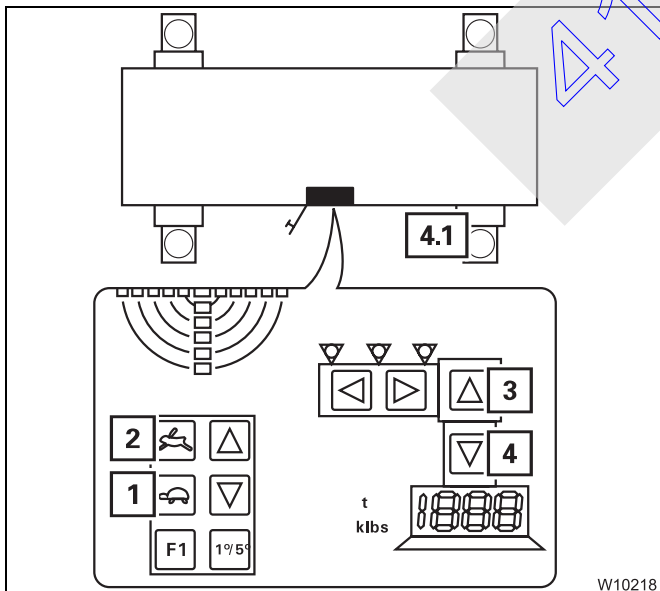

The operation is the same for all supporting cylinders.

- Press the button
 - 1 for normal speed, or
 - 2 for high-speed mode.
- Also press the button for the desired supporting cylinder, e.g. for 4.1.
 - 3 For retracting
 - 4 For extending

You can also operate several supporting cylinders at the same time.

The outriggers move until you let go of the respective button or until the respective end position has been reached.

With the hand-held control

- Connect the hand-held control to any socket on the carrier; p. 13 - 20.

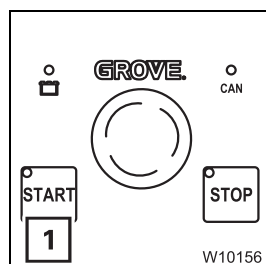

To start the engine

- Press the button (1) – the engine starts; p. 11 - 17.

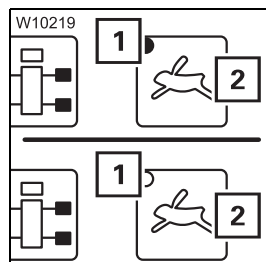

Pre-select high-speed mode / normal speed

- Press the button (2).
 - Lamp (1) lights up – high-speed mode pre-selected,
 - Lamp (1) goes out – normal speed pre-selected.

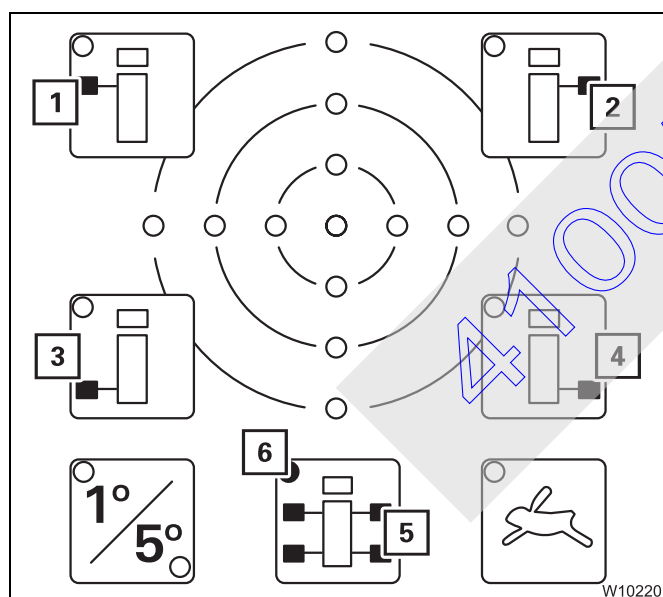

Pre-select outriggers

- Press the button for the required outrigger once

- 1 Front left
- 2 Front right
- 3 Rear left
- 4 Rear right
- 5 All

Pre-selection is switched on and the lamp in the corresponding button lights up, e.g. the lamp (6).

After about 10 seconds the pre-selection is switched off.



Combinations of the buttons (1) to (4) are also possible, e.g. buttons (1) and (2), in order to lift the truck crane at the front.



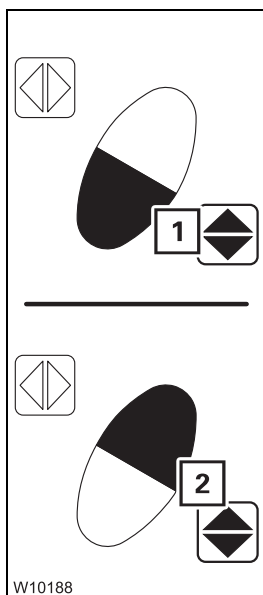

Extending / retracting supporting cylinders

- Observe the safety instructions for operating the supporting cylinders;
 ■■■▶ p. 13 - 41.
- Press the button combination for the desired movement:
 - 1 Extend
 - 2 Retract

The pre-selected supporting cylinders move until you let go of the respective button or until the respective end position has been reached.

From the crane cab

The following operating elements are in the *Outriggers* submenu.

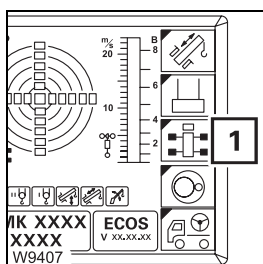

Opening the submenu

- If necessary, open the main menu  and press the button (1) once.

The *Outriggers* submenu opens.

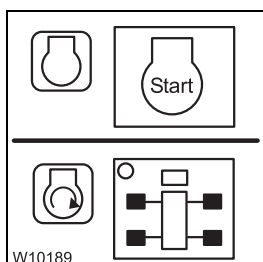

To start the engine

- Switch the carrier ignition on and start the engine for driving;
 ■■■▶ p. 13 - 23.
- Switch off the slewing gear

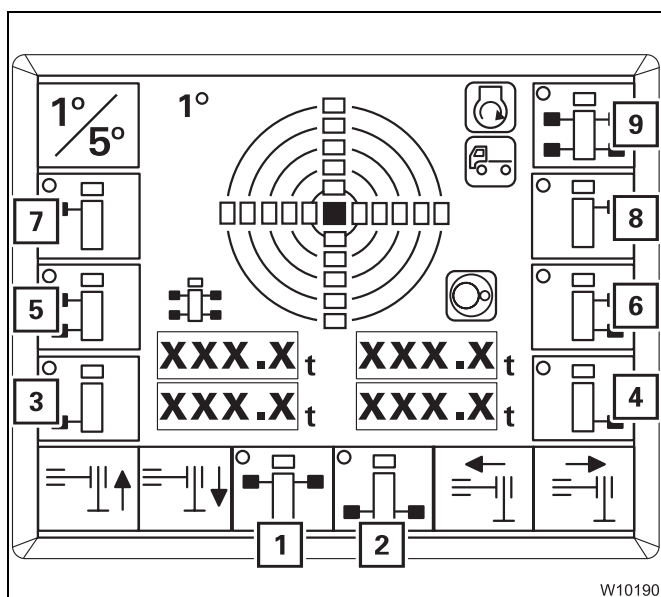

Pre-select outriggers

- Press the button once next to the symbol for the desired outrigger:

- 1 Both at front
- 2 Both at rear
- 3 Rear left
- 4 Rear right
- 5 Both on left
- 6 Both on right
- 7 Front left
- 8 Front right
- 9 All

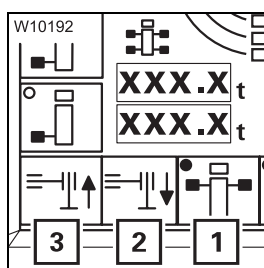

Pre-selection is switched on.

- The dot in the symbol turns **green**, e.g. in symbol (1).
- The symbols (2) and (3) turn **black**.

After about 10 seconds the pre-selection is switched off.

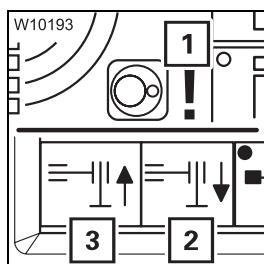

If the symbol (1) appears, this means that the slewing gear is switched on – the symbols (2) and (3) remain grey.

- Switch off the slewing gear

Extending / retracting supporting cylinders

- Observe the safety instructions for operating the supporting cylinders;
 p. 13 - 41.

- Press the button below the symbol for the desired movement:

- 1 Retract
- 2 Extend

The pre-selected supporting cylinders move until you let go of the respective button or until the respective end position has been reached.

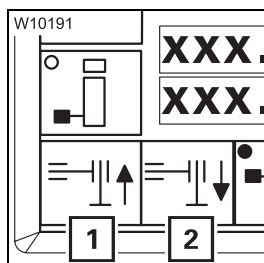

13.6.10 Levelling the truck crane on outriggers

You must level the truck crane before crane operation and possibly correct its horizontal alignment during crane operation.

Inclination displays

After switching on the ignition, various inclination indicators display the current alignment.

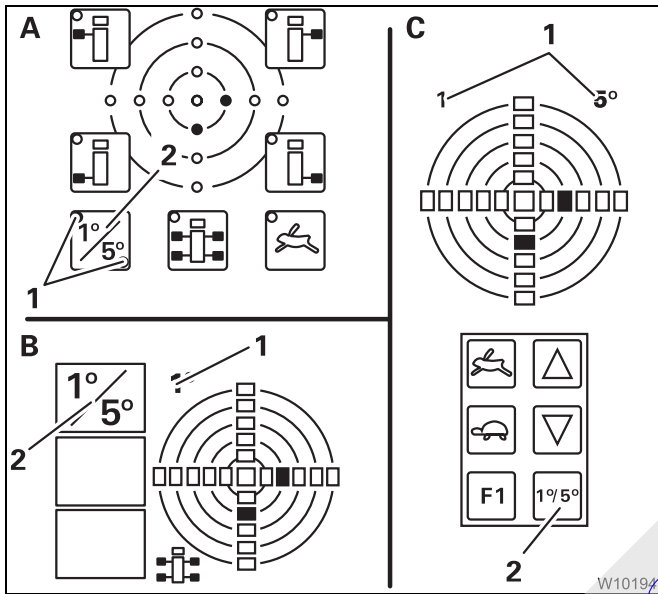

- A** On the hand-held control
- B** On the *ECOS* display in the main menu, and in the *Outrigger submenu*
- C** On the *Outrigger control units*

Switching over the measuring range

You can change the measuring range between 1° and 5°.

- Press the button (2) once.
The current measuring range (1) is displayed.

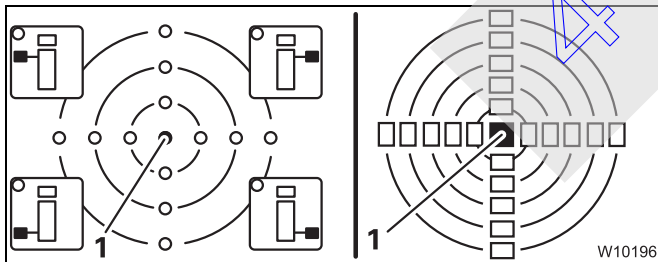

Read the display

Only the lamp (1) at the centre is on if the truck crane is level.

The other lamps show the sides of the truck crane which are higher.

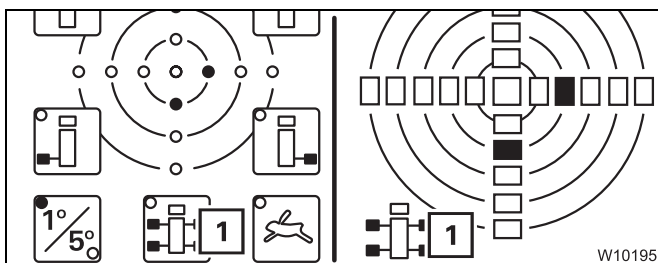

– *ECOS* hand-held control / display

The assignment to the carrier is given by the directional indicator (1).

In this example, the carrier would be standing higher to the rear on the right hand side.

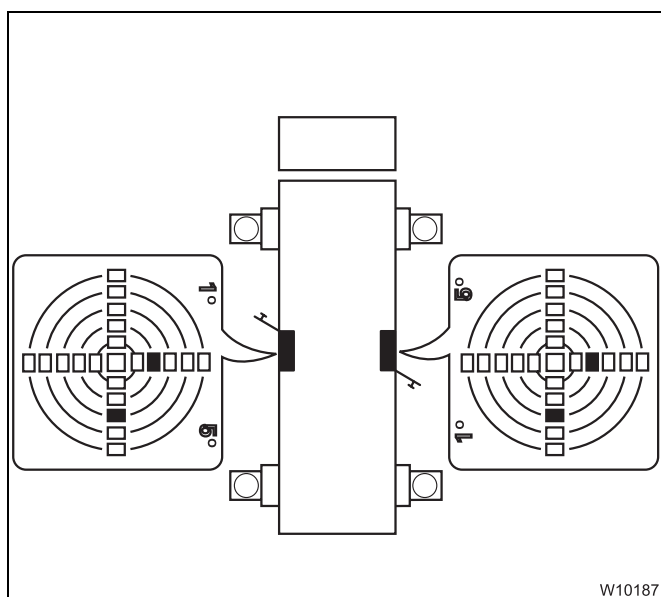

– *Outrigger control units*

The assignment to the carrier corresponds to the top view.

Due to the position of the control units, the displays on both sides differ.

In this example, the carrier would be standing higher to the rear on the right hand side.

Prerequisites

The following prerequisites apply to manual and automatic alignment.

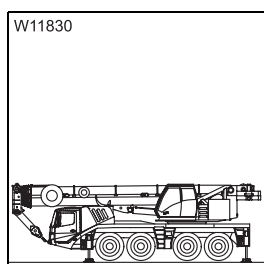

The main boom must be resting on the boom rest

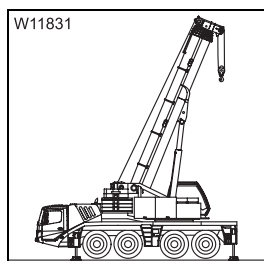

Or

- The main boom must be raised **and**
- the load has been set down **and**
- the superstructure is in the 0° or 180° position.



Risk of overloading the main boom

Always slew the superstructure to the 0° or 180° position and set down the load before levelling the truck crane.

In other positions the deformation of the carrier will create incorrect results for the inclination and the truck crane will be at an angle. This could cause the outrigger beam to become overloaded during crane operation.



Manual alignment

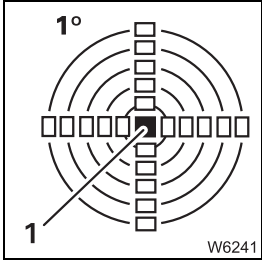
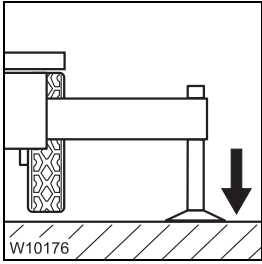

- Check that the prerequisites are met;  p. 13 - 47.
- Extend all supporting cylinders until none of the wheels is touching the ground.

- Level the truck crane with the supporting cylinders horizontally until the lamp (1) is the only one lighting up in the measuring range 1°;  p. 13 - 41.
- Only lift the truck crane as much as necessary.

Checks to be performed after levelling

During levelling, the ground may give way and the packing may slip.

Risk of accidents due to incorrectly supported truck crane

Perform the following checks each time you have levelled the truck crane and correct any misalignments.

Otherwise the truck crane may overturn even when lifting a load released by the SLI.



- Check after you have levelled the truck crane:
 - whether all the wheels are lifted off the ground,
 - whether the ground under one of the outrigger pads has given way,
 - whether the packing is correct for the enlarged ground bearing area.

If slewing is permissible with the current rigging mode:

- Slew the superstructure within the permissible slewing range.
- Perform the specified checks again.
- Check the horizontal alignment on the inclination display.

Automatic alignment

During the automatic alignment procedure, the supporting cylinders are only **extended** to prevent any wheels from touching the ground after the alignment.

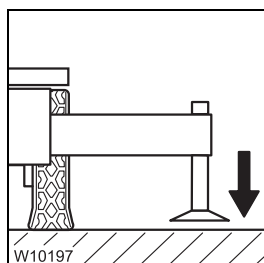

- Check that the prerequisites are met;  p. 13 - 47.
- Extend the supporting cylinders until the outrigger pads are just above the ground.

Start procedure

Depending on the truck crane's equipment, you can start the procedure from the hand-held control and the *Outriggers* control units.

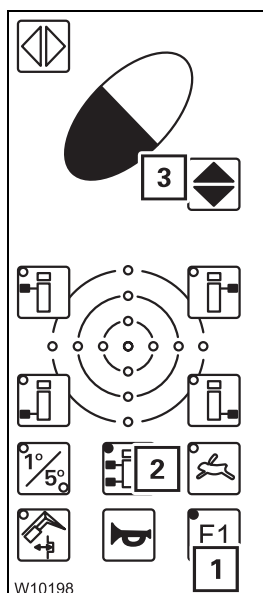

– On the hand-held control

- Press the button **(1)** once.
- Press the button **(2)** once.

The lights in the buttons go on.

- Press the button combination **(3)** for automatic alignment. The procedure begins.

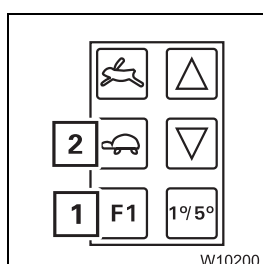

– On the control units

- Press the button **(1)**.
- Additionally, press the button **(2)**.

The procedure begins.



Automatic procedure

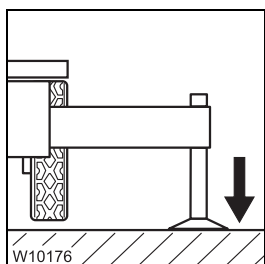

1. All supporting cylinders are extended one after the other until the outrigger pads touch the ground.
2. All supporting cylinders extend simultaneously so that none of the wheels touch the ground anymore.

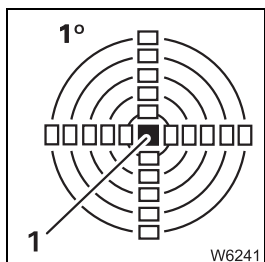

3. The truck crane is automatically levelled.

This procedure is performed

- until horizontal alignment is reached, the lamp (1) in the centre is the only one lighting up in measuring range 1° or
- until you let go of a button or
- until horizontal alignment is no longer possible, e.g. when a supporting cylinder is extended as far as possible.



Danger of overturning if the truck crane is not level

When ECOS ends the automatic alignment procedure, the truck crane is not necessarily level.

Always check the horizontal alignment on the inclination display after automatic levelling.

41005061

13.6.11

Levelling the free-standing truck crane

The suspension is deactivated (locked) if the truck crane is in the *Free on wheels* working position.

The suspension has to remain switched off until the truck crane is on outriggers.



Danger of overturning if the supporting cylinders are operated unevenly!

Extend or retract the supporting cylinders as evenly as possible.

In this way you can prevent the truck crane from overturning when operating individual supporting cylinders.

- Set down the load.
- Extend the supporting cylinders until all wheels are just above the ground.

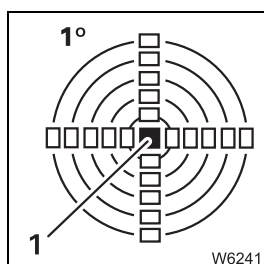
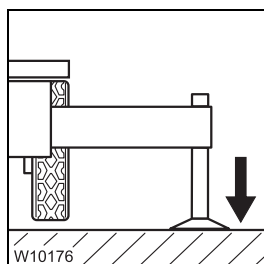

Levelling the truck crane

- Level the truck crane on outriggers until the lamp (1) is the only one lighting up in the measuring range 1°.



Danger of overturning when switching on the suspension

You may under no circumstances switch on the suspension as long as the rigged truck crane is on wheels. The suspension struts would be suddenly pressed together and damaged and the truck crane could overturn when switching on the suspension.

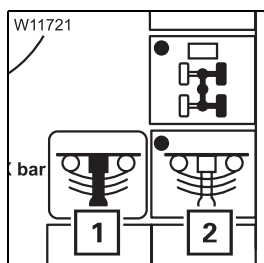

Switching on the suspension

- In the driver's cab, open the *Level adjustment system* submenu – button .
- Press the button (2) once – dot **green**.
The symbol 1 is **green** if the suspension is switched on.



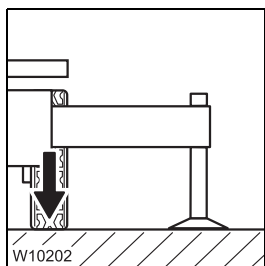

Now all wheels are lowered to the ground and are in the right position for the horizontal alignment.

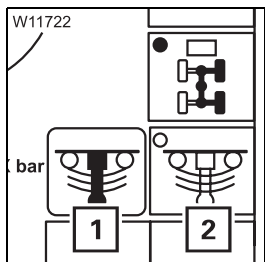

To switch off the suspension

- Press the button (2) once – dot **black**.
The symbol (1) is **red** if the suspension is switched off.

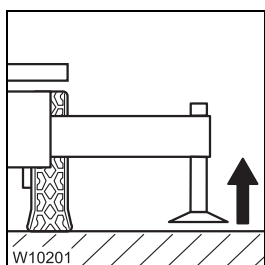

To secure the truck crane

- Retract the supporting cylinders until the outrigger pads are about 5 to 10 cm (2 to 4 in) above the ground. Leave the outrigger beams extended.

41005061

13.6.12 Outrigger pressure display

After switching on the ignition, the outrigger pressure displays indicate the current outrigger pressure for all outrigger cylinders.
The set unit (t or klbs) is shown next to the displays.



Outrigger cylinders retracted or extended as far as possible will create incorrect outrigger pressure readings.
The display will show the most accurate reading if the movement performed last was *Extend outrigger cylinders*.

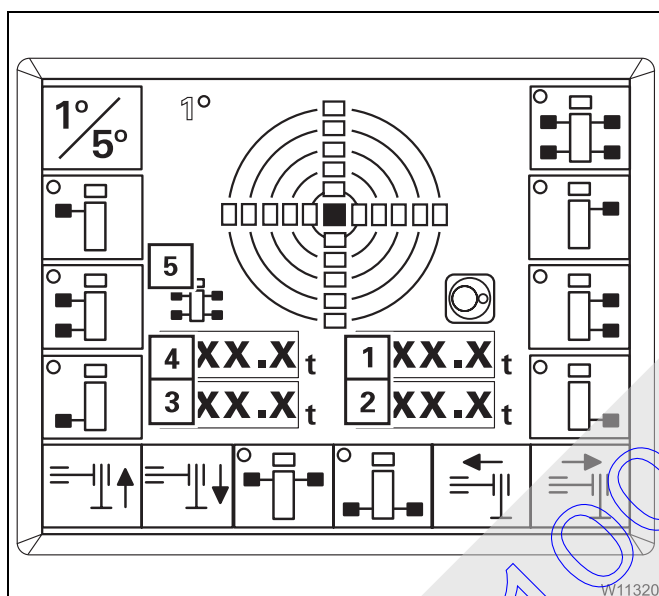

In the Outriggers submenu

The assignment of the displays to the carrier is given by the directional indicator (5).

- 1 Front right outrigger pressure
- 2 Rear right outrigger pressure
- 3 Rear left outrigger pressure
- 4 Front left outrigger pressure

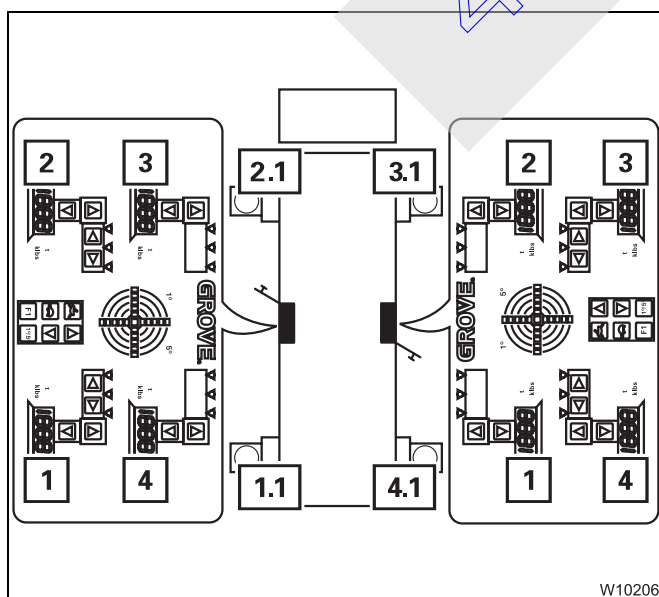

On the Outrigger control units

The assignment of the displays to the carrier corresponds to the top view.

- 1 Display for the outrigger cylinder 1.1
- 2 Display for the outrigger cylinder 2.1
- 3 Display for the outrigger cylinder 3.1
- 4 Display for the outrigger cylinder 4.1

Blank page

41005067

13.7

Rigging / unrigging the counterweight

There are counterweight masses of 4.1 t (9,000 lbs) to 26.1 t (57,540 lbs) available for the GMK 4100.

13.7.1

Counterweight parts

There are various counterweight parts, depending on the truck crane's version and additional equipment.

Version A

This version enables you to drive with maximum axle loads of 12 t (26,500 lbs).

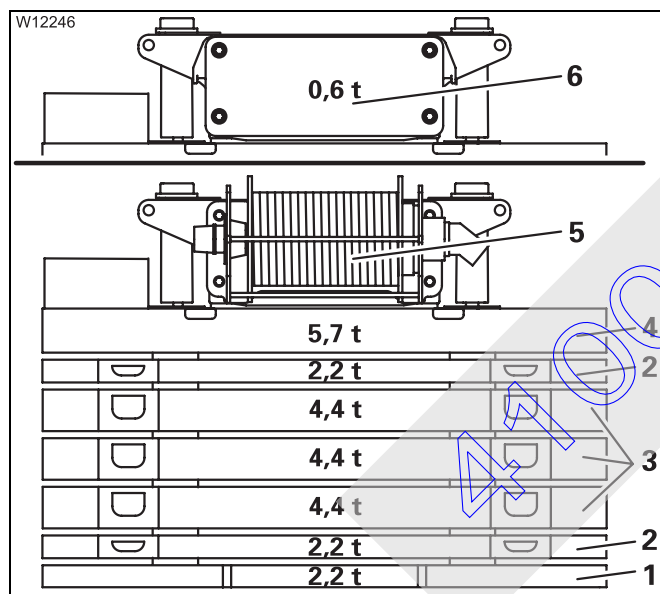

6.3 t (13,800 lbs) counterweight

Firmly mounted on the turntable:

- one 5.7 t plate (4),
- one 0.6 t plate (6) or the auxiliary hoist (5).

26.1 t (57,540 lbs) counterweight

As additional equipment:

- two 2.2 t plates (2)
- three 4.4 t plates (3)
- one 2.2 t base plate (1)



Version B

With this version it is possible to drive with axle loads of under 12 t (26,500 lbs).

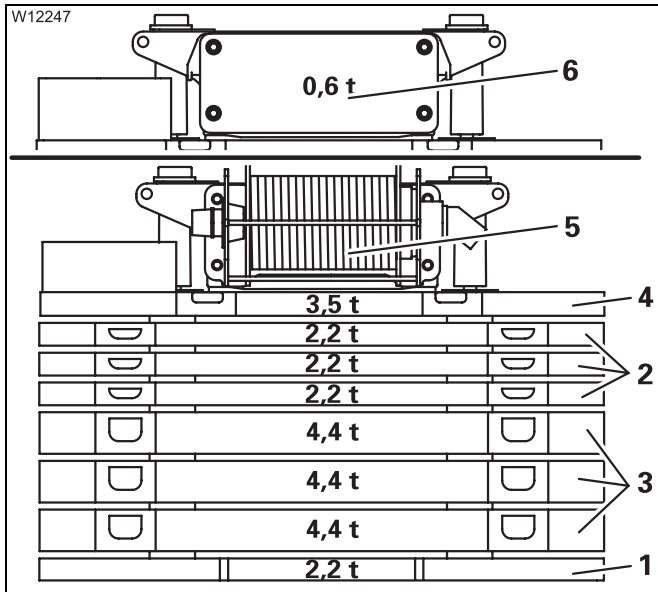

4.1 t (9,000 lbs) counterweight

Firmly mounted on the turntable:

- one 3.5 t plate (4),
- one 0.6 t plate (6) or the auxiliary hoist (5).

26.1 t (57,540 lbs) counterweight

As additional equipment:

- three 2.2 t plates (2)
- three 4.4 t plates (23)
- one 2.2 t base plate (1)

Version C

With this version, 21.7 t maximum counterweight can be transported with the truck crane. The axle loads are over 12 t (26,500 lbs),

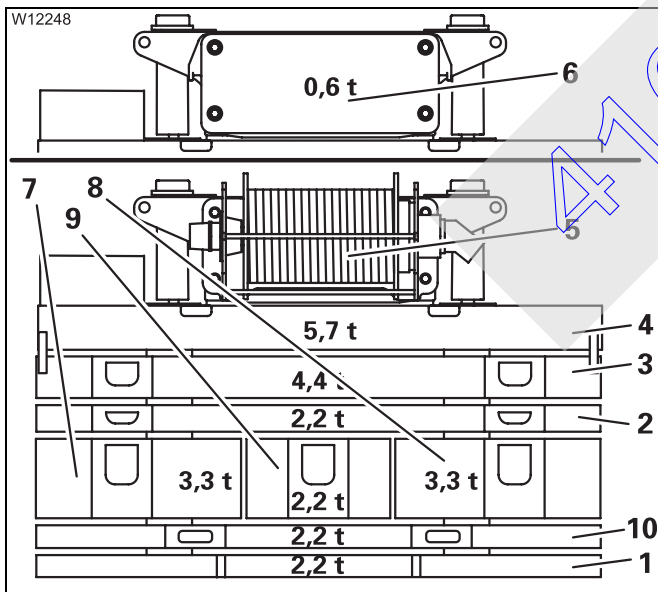

6.3 t (13,800 lbs) counterweight

Firmly mounted on the turntable:

- one 5.7 t plate (4),
- one 0.6 t plate (6),
- or auxiliary hoist (5)

26.1 t (57,540 lbs) counterweight

As additional equipment:

- one 4.4 t plate¹⁾ (3),
- one 2.2 t plate (2)
- in each case, one 3.3 t plate (7) and (8)
- one 2.2 t plate (9)
- one 2.2 t plate¹⁾ (10)
- one 2.2 t base plate (1)

¹⁾ Can be mounted on the turntable



This version contains a different 2.2 t base plate than versions A and B in order to enable slewing with mounted 4.4 t plate.

13.7.2

Identification

The truck crane and its corresponding counterweight sections are labelled with the same serial number.

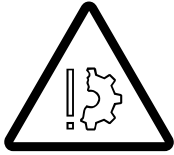

Danger if counterweight sections are interchanged

Use only counterweight parts that belong to your truck crane. The truck crane and counterweight sections are labelled with the same serial number. Other or additional counterweight sections may not be rigged.

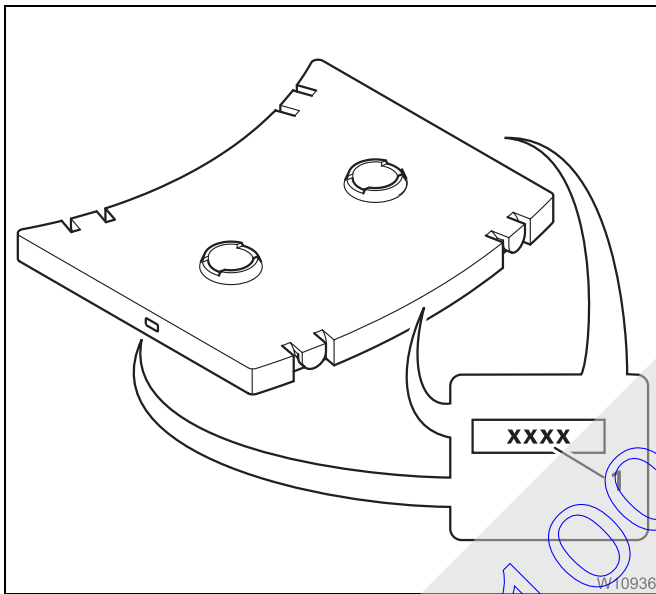

The serial number (1) of all sections is either on the back or indicated together with the weight.

13.7.3

Slings points



Danger of accidents if used improperly

Slings the counterweight parts only on the designated points and use only lifting gear with sufficient load bearing capacity.

Before lifting plates which are lying on top of each other, make note of the permitted weights.

- Only use lifting gear of sufficient lifting capacity; Counterweight parts, p. 16 - 3.

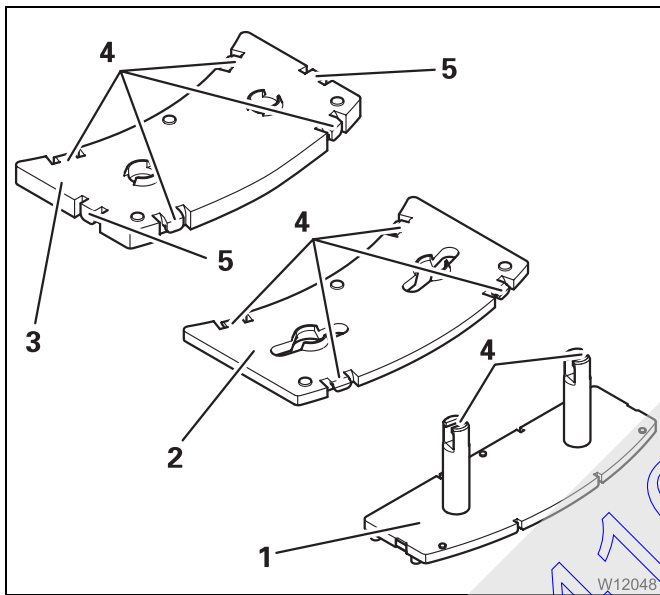

The slings points (4) are designed for lifting plates which are lying on top of each other.

The maximum permitted weight of additional plates which are laid on with the

- 2.2 t base plate (1) is: 6.6 t (14,500 lbs)
- 2.2 t plate (2): 4.4 t (9,700 lbs)
- 4.4 t plate (3): 8.8 t (19,400 lbs)

Do not sling the plate (3) at the points (5).

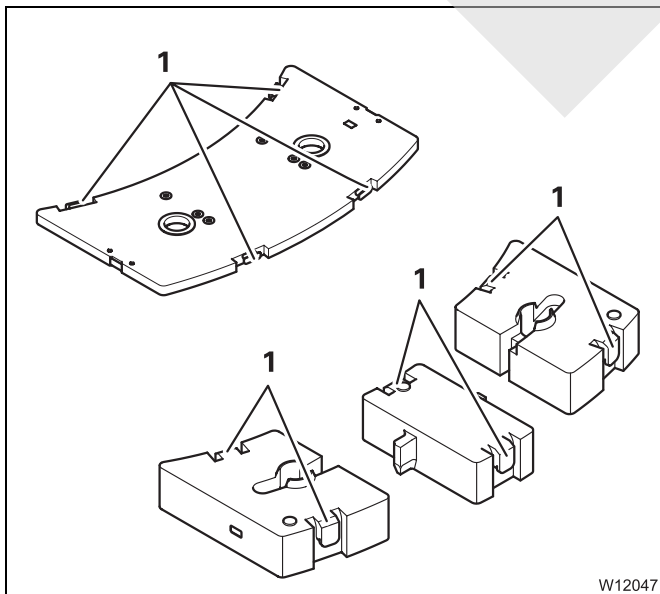

With some plates in version C, the slings points (1) are only designed for the dead weight of the plates.

13.7.4

CHECKLIST: Rigging counterweight



This checklist is not a complete set of operating instructions. There are accompanying operating instructions which are referred to by cross-references.

Observe the warnings and safety instructions specified there.



Danger of overturning when slewing with a rigged counterweight

Always check before slewing whether slewing is permitted in the truck crane's current rigging mode (counterweight, outrigger span, working radius).

Correct the rigging mode if necessary; *Slewing with rigged counterweight*, p. 13 - 82.

1. Check whether the truck crane is supported with the required outrigger span as specified in the *Lifting capacity table*; *Permissible outrigger spans*, p. 13 - 28.

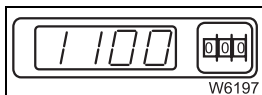

2. Enter the current rigging mode on the SLI; p. 12 - 21.

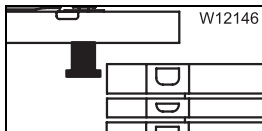

3. **With version C**

Check whether a plate has to be mounted on the turntable in order to avoid damaging the lifting cylinders; p. 13 - 63.

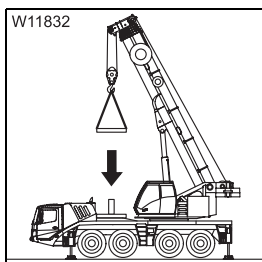

4. Assemble the required counterweight combination and fold in the slinging points on the 2.2 t base plate;

Slinging points, p. 13 - 58,

Assembling counterweight versions, p. 13 - 61,

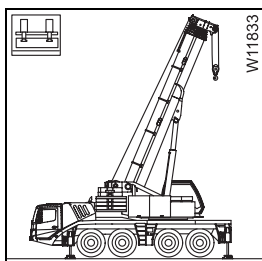

5. – Open the *Counterweight* submenu; p. 13 - 72.

– Correct the rigging mode, if necessary; p. 13 - 73.

– Slew the superstructure into the rigging range and lift counterweight to the turntable (automatic) and pre-charge; p. 13 - 74.

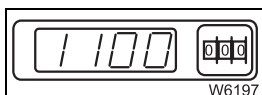

6. Enter the current rigging mode with the newly rigged counterweight version on the SLI; p. 12 - 21.

13.7.5

CHECKLIST: Unrigging counterweight



This checklist is not a complete set of operating instructions. There are accompanying operating instructions which are referred to by cross-references.

Observe the warnings and safety instructions specified there.



Danger of overturning when slewing with a rigged counterweight

Before slewing with the rigged counterweight, check whether slewing is permissible with the rigged outrigger span; *Slewing with rigged counterweight*, p. 13 - 82.

1. Check whether the truck crane is supported with the required outrigger span as specified in the *Lifting capacity table*; *Permissible outrigger spans*, p. 13 - 28.

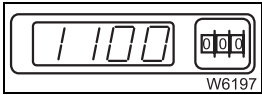

2. Enter the current rigging mode on the SLI; p. 12 - 21.

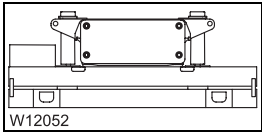

3. With version C

When a plate should not be lowered with the counterweight, check whether it is mounted on the turntable; p. 13 - 63.

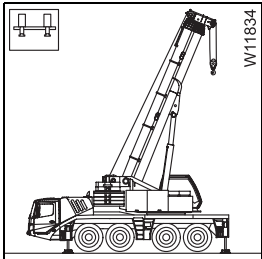

4. – Open the *Counterweight* submenu; p. 13 - 72.

– Slew the superstructure into the rigging range and set down the counterweight onto the counterweight platform (automatic); p. 13 - 75.

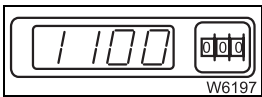

5. Enter the current rigging mode with the presently rigged counterweight version on the SLI; p. 12 - 21.

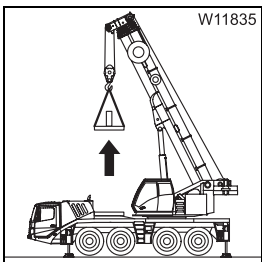

6. Lift the counterweight sections off the counterweight platform, as required by the respective driving mode;
 Slings points, p. 13 - 58,
 Driving modes, p. 6 - 1.

13.7.6

Assembling counterweight versions



Danger of overturning when slewing with a rigged counterweight

When a counterweight version is rigged, check whether slewing is permitted with the current rigging mode (outrigger span, working radius). Correct the rigging mode if necessary; **▶▶▶▶** *Slewing with rigged counterweight*, p. 13 - 82.



Danger of crushing when setting down the counterweight sections

Make sure any helpers keep a sufficient distance away from the counterweight sections with any parts of their body when setting down the counterweight sections.

Remove all objects from the counterweight platform that could become jammed or crushed



Danger of crushing when slewing the superstructure

The access ladders are located in the slewing range of the superstructure. Make sure nobody uses the access ladders (helpers for example) while you lift a counterweight section onto the counterweight platform.

On the turntable

Depending on the version, different counterweight combinations can be mounted on the turntable.

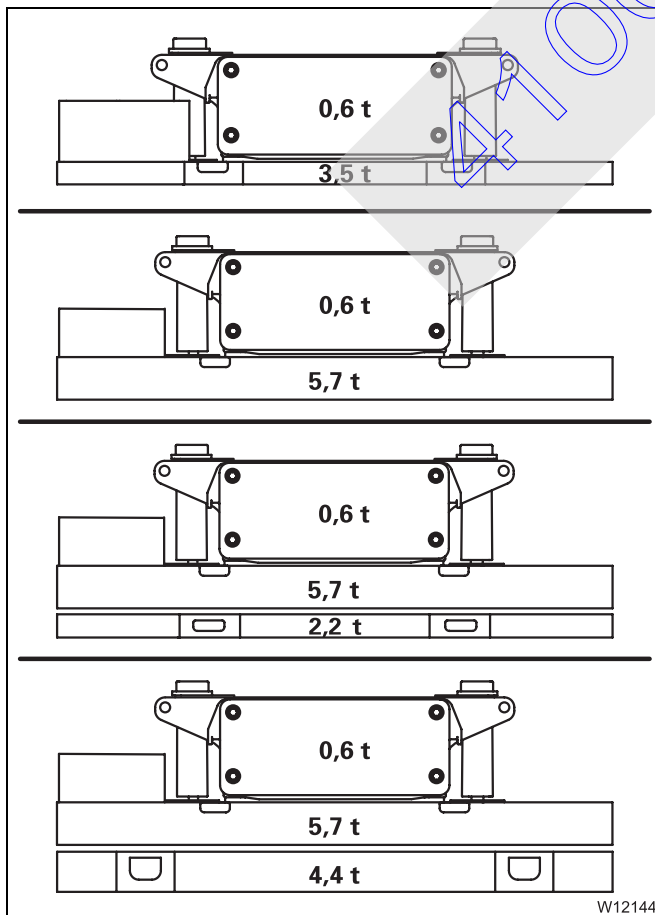

4.1 t (9,000 lbs)

Is firmly mounted on the turntable with version **B**.

6.3 t (13,800 lbs)

Is firmly mounted on the turntable with version **A** and version **C**.

8.5 t (18,700 lbs)

Can only be mounted on the turntable with version **C**; **▶▶▶▶** p. 13 - 77.

10.7 t (23,500 lbs)

Can only be mounted on the turntable with version **C**; **▶▶▶▶** p. 13 - 77.

23.11.2006



With the base plate

Counterweight combinations which cannot be mounted on the turntable are lifted together with the 2.2 t base plate onto the turntable.



Risk of accidents due to falling counterweight sections

Only attach the counterweight sections to the appropriate slinging points and use lifting gear of sufficient lifting capacity. The plates should be lifted only one at a time.

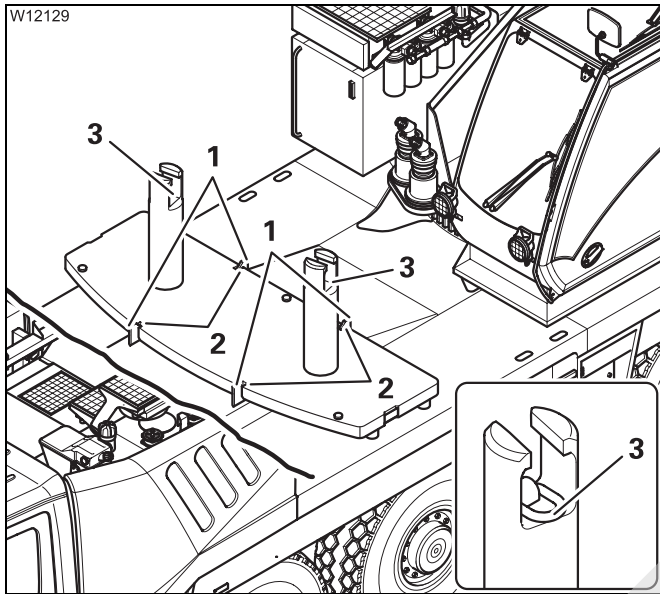

Setting down the 2.2 t base plate

- Position the 2.2 t base plate in such a way that the cutouts (2) grip into the retaining sheets (1).
- Fold up the slinging points (3).

When assembling the counterweight combinations, additional plates are set onto the 2.2 t base plate.

- Observe the following information.



Risk of damage when slinging point is folded out

Always fold in the slinging points. This prevents the lifting cylinders from turning against the slinging points and being damaged.

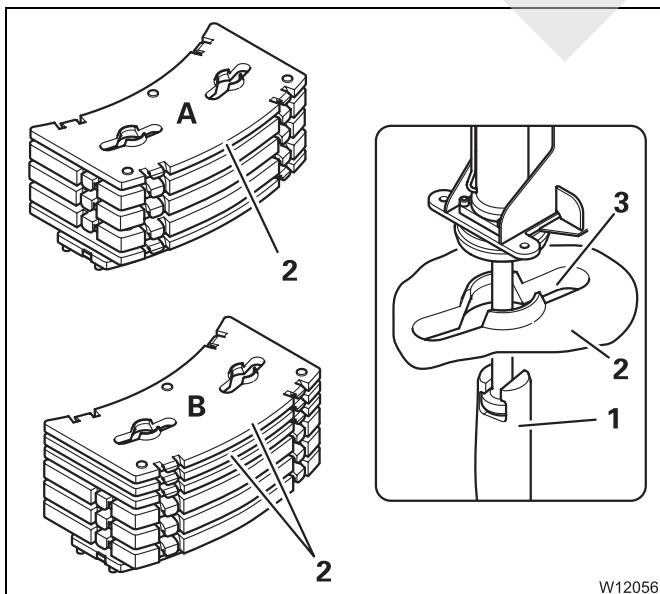

Version A

With 26.1 t (57,500 lbs) one 2.2 t plate (2) must always lie at the top so that the lifting cylinders within the cutouts (3) can be turned into the 2.2 t base plate (1).

Version B

With 23.9 t (52,600 lbs) and with one 26.1 t (57,500 lbs) two 2.2 t plates (2) must always lie at the top so that the lifting cylinders within the cutouts (3) can be turned into the 2.2 t base plate (1).

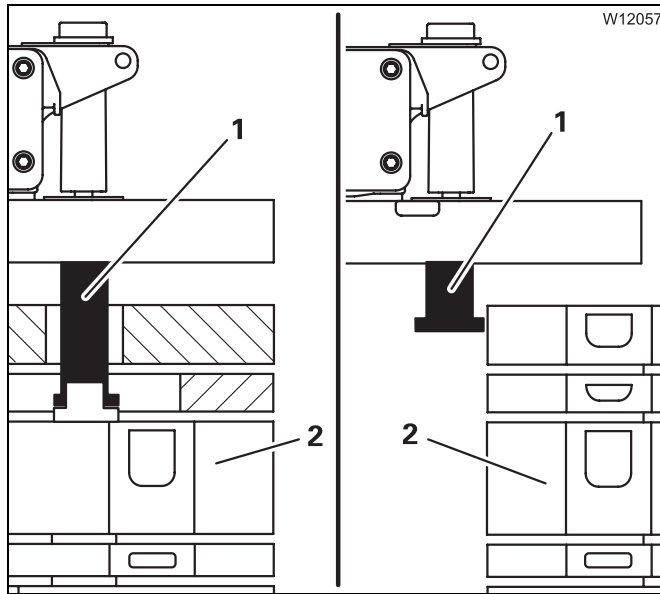

Version C

Before assembling

- 26.1 t (57,500 lbs) or
 - 23.9 t (52,600 lbs) with the 3.3 t plates (2)
- the 4.4 t plate or the 2.2 t plate must always be mounted on the turntable;  p. 13 - 77.

Otherwise, the lifting cylinders (1) will knock against the counterweight which has been stacked too high during rigging.



Risk of damage to the lifting cylinders!

If necessary, mount the 4.4 t plate or the 2.2 t plate on the turntable, so that the lifting cylinders do not knock against the assembled counterweight while slewing.

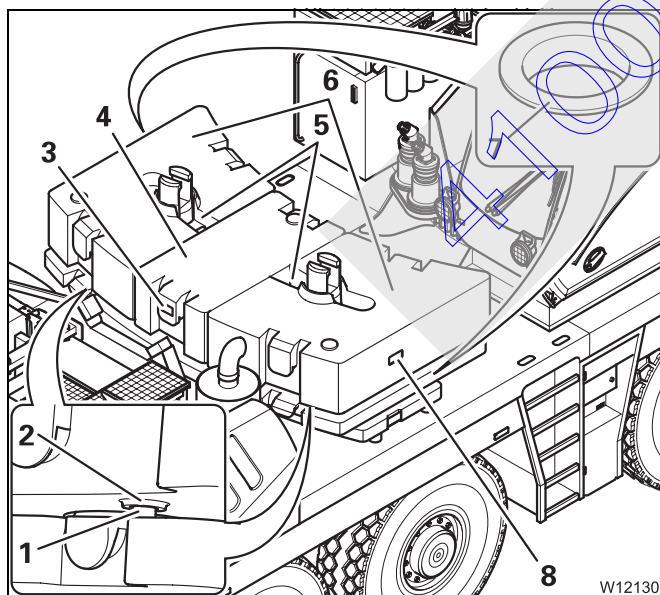

Plates with round cutouts (7) must always be set down first, so that the cutouts (5) are accessible.

- Set down the 3.3 t plates (6) in such a way that
- the weight information (8) is on the outside, and
 - the mountings (2) surround the pegs (1).

The 2.2 t plate (4) is positioned correctly when its weight (3) is shown at the front. Otherwise, this plate protrudes out from the other plates at the rear.



With version A

The illustration and the table show all counterweight sections and all counterweight combinations which can be rigged.

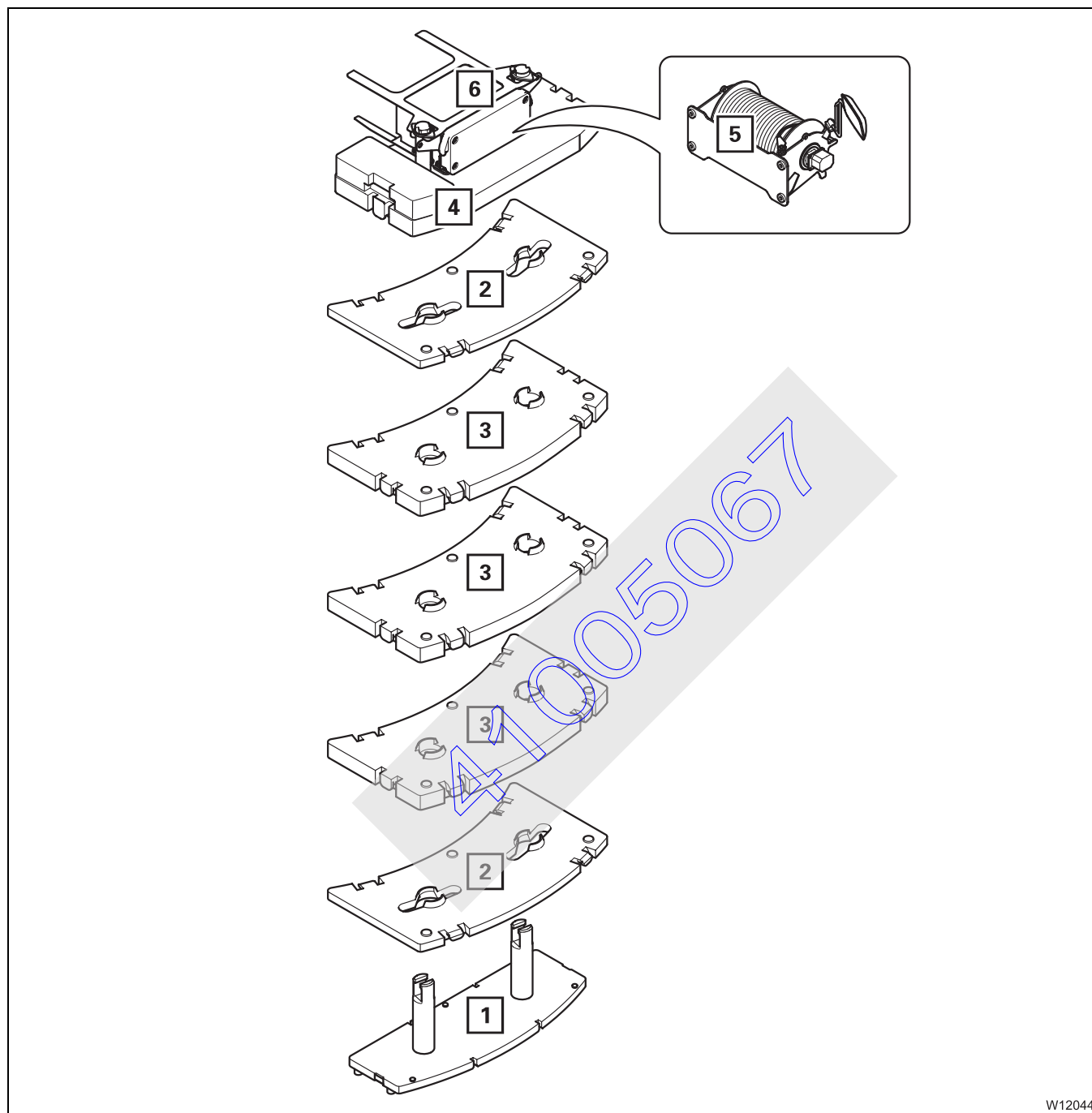

W12044

- The tables specify what counterweight sections are needed for the respective counterweight versions.
- Lift the counterweight sections onto the base plate;  *Slings points*, p. 13 - 58.



Risk of damage to the counterweight

With the 26.1 t (57,500 lbs) counterweight combination, a 2.2 t plate **2** must always be placed on top.

This prevents the lifting cylinders and counterweight from being damaged while rigging.

Counterweight sections	Counterweight version in t (lbs)				
	6.3 (13 800)	8.5 (18 700)	10.7 (23 500)	12.9 (28 400)	15.1 (33 200)
6.3 t on the turntable	4 + 6 or 4 + 5				
4.4 t section	-	-	-	3 ¹⁾	3
2.2 t section	-	-	2	-	2
2.2 t base plate	-	1	1	1	1

Counterweight sections	Counterweight version in t (lbs)				
	17.3 (38 100)	19.5 (42 900)	21.7 (47 800)	23.9 (52 600)	26.1 (57 500)
6.3 t on the turntable	4 + 6 or 4 + 5				
4,4 t section	2 x 3 ¹⁾	2 x 3	3 x 3 ¹⁾	3 x 3	3 x 3
2.2 t section	-	2	-	2	2 x 2
2.2 t base plate	1	1	1	1	1

¹⁾ For 1 x **3** 2 x **2** can also be used



With version B The illustration and the table show all counterweight sections and all counterweight combinations which can be rigged.

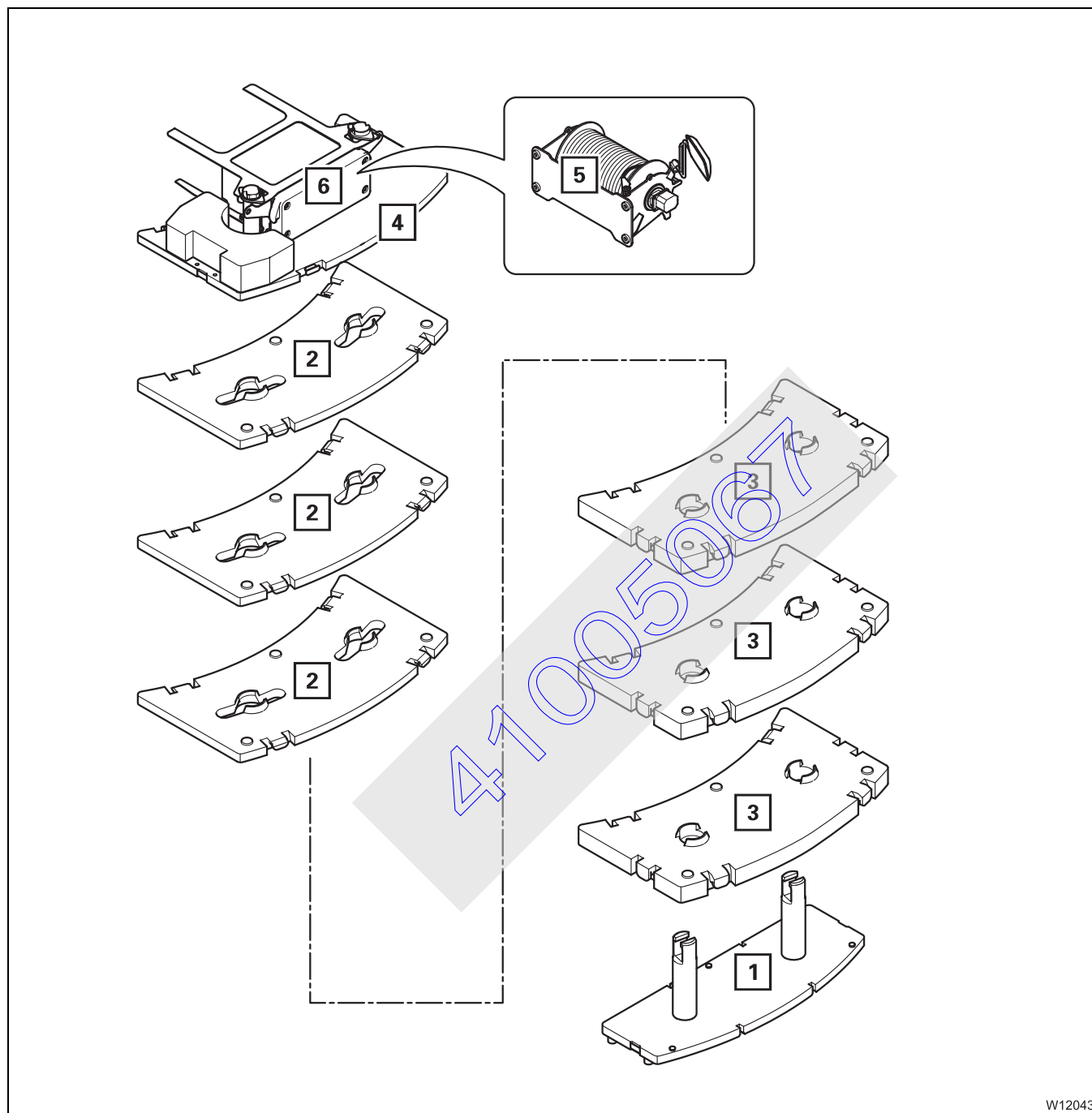

- The tables specify what counterweight sections are needed for the respective counterweight versions.
- Lift the counterweight sections onto the base plate;  *Slinging points*, p. 13 - 58.



Risk of damage to the counterweight

With the 23.9 t (52,600 lbs) and 26.1 t (57,500 lbs) counterweight combinations, two 2.2 t plates **2** must always be placed on top. This prevents the lifting cylinders and counterweight from being damaged while rigging.

Counterweight sections	Counterweight version in t (lbs)					
	4.1 (9 000)	6.3 (13 800)	8.5 (18 700)	10.7 (23 500)	12.9 (28 400)	15.1 (33 200)
4.1 t on the turntable	4 + 6 or 4 + 5					
4.4 t section	-	-	-	3 ¹⁾	3 ¹⁾	2 x 3 ¹⁾
2.2 t section	-	-	2	-	2	-
2.2 t base plate	-	1	1	1	1	1

Counterweight sections	Counterweight version in t (lbs)				
	17.3 (38 100)	19.5 (42 900)	21.7 (47 800)	23.9 (52 600)	26.1 (57 500)
4.1 t on the turntable	4 + 6 or 4 + 5				
4.4 t section	2 x 3 ¹⁾	3 x 3 ¹⁾	3 x 3 ¹⁾	3 x 3	3 x 3
2.2 t section	2	-	2	2 x 2	3 x 2
2.2 t base plate	1	1	1	1	1

¹⁾ For 1 x **3** 2 x **2** can also be used



With version C

The illustrations and the tables show all counterweight sections and all counterweight combinations which can be rigged.

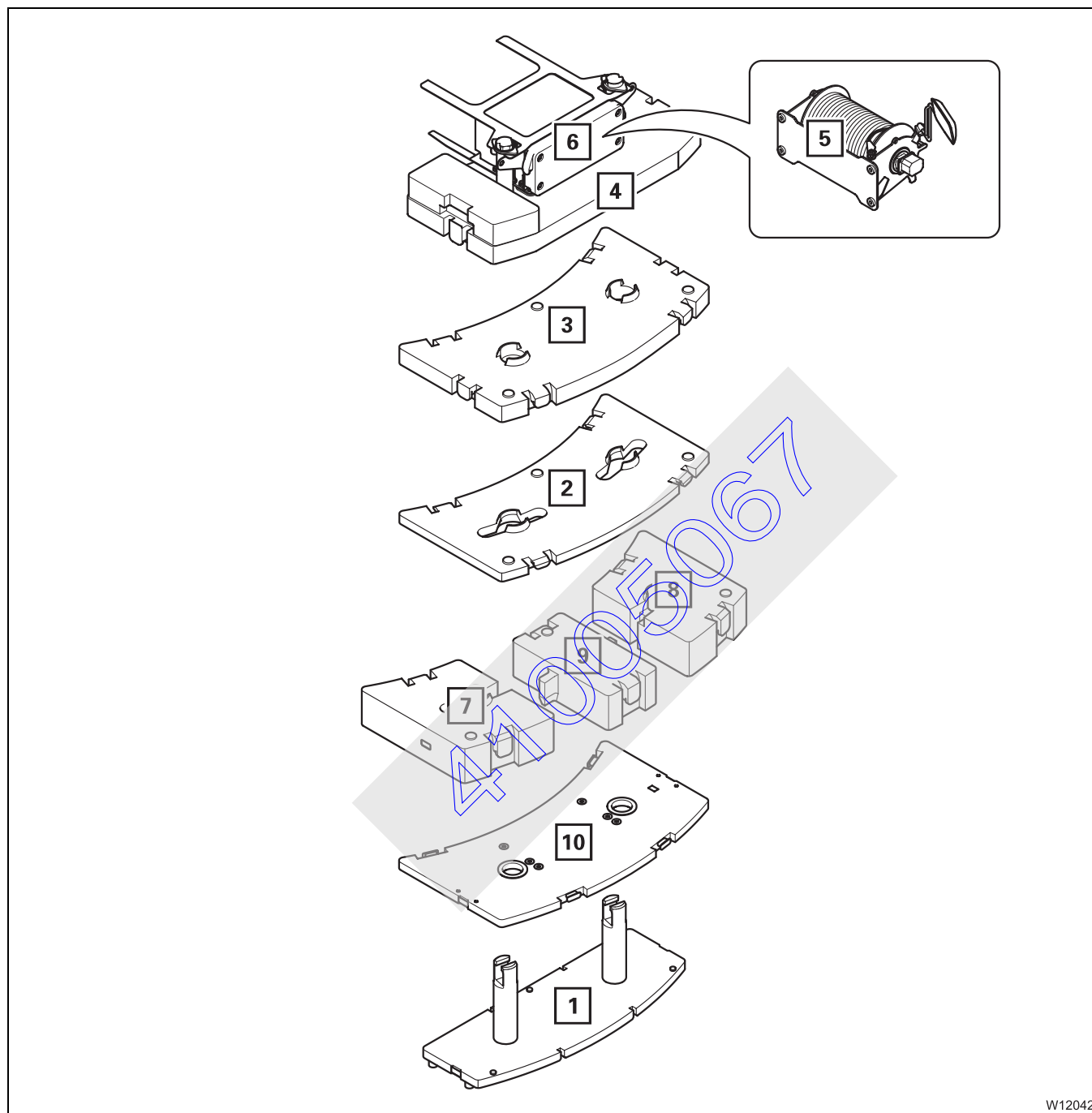

- The tables specify what counterweight sections are needed for the respective counterweight versions.
- Lift the counterweight sections onto the base plate;  *Slings points*, p. 13 - 58.



Risk of damage to the lifting cylinders!

If necessary, mount the plate **3** or **10** on the turntable, so that the lifting cylinders do not knock against the assembled counterweight while slewing.

Version C, p. 13 - 63.

Generally, plates **3** and **10** which have been set down must always be placed below the plates **7** and **8**.

Counterweight sections	Counterweight version in t (lbs)						
	6.3 (13 800)	8.5 (18 700)	10.7 (23 500)	12.9 (28 400)	15.1 (33 200)	17.3 (38 100)	
6.3 t on the turntable	4 + 6 or 4 + 5						
4.4 t section	-	-	3 ⁴⁾	3 ¹⁾	3	-	-
3.3 to plates	-	-	-	-	7 8	7 8 ⁵⁾	7 8
2.2 t section	-	10 ³⁾	-	-	2 ²⁾	9	2 ²⁾
2.2 t base plate	-	-	-	1	1	1	1

1) For **3**, **2** + **10** can also be used

2) For **2**, **10** can be used

3) For **10**, **1** can be used

4) For **3**, **1** + **2** or **1** + **10** can also be used

5) For **7** **8** **9**, **2** **3** **10** can be used



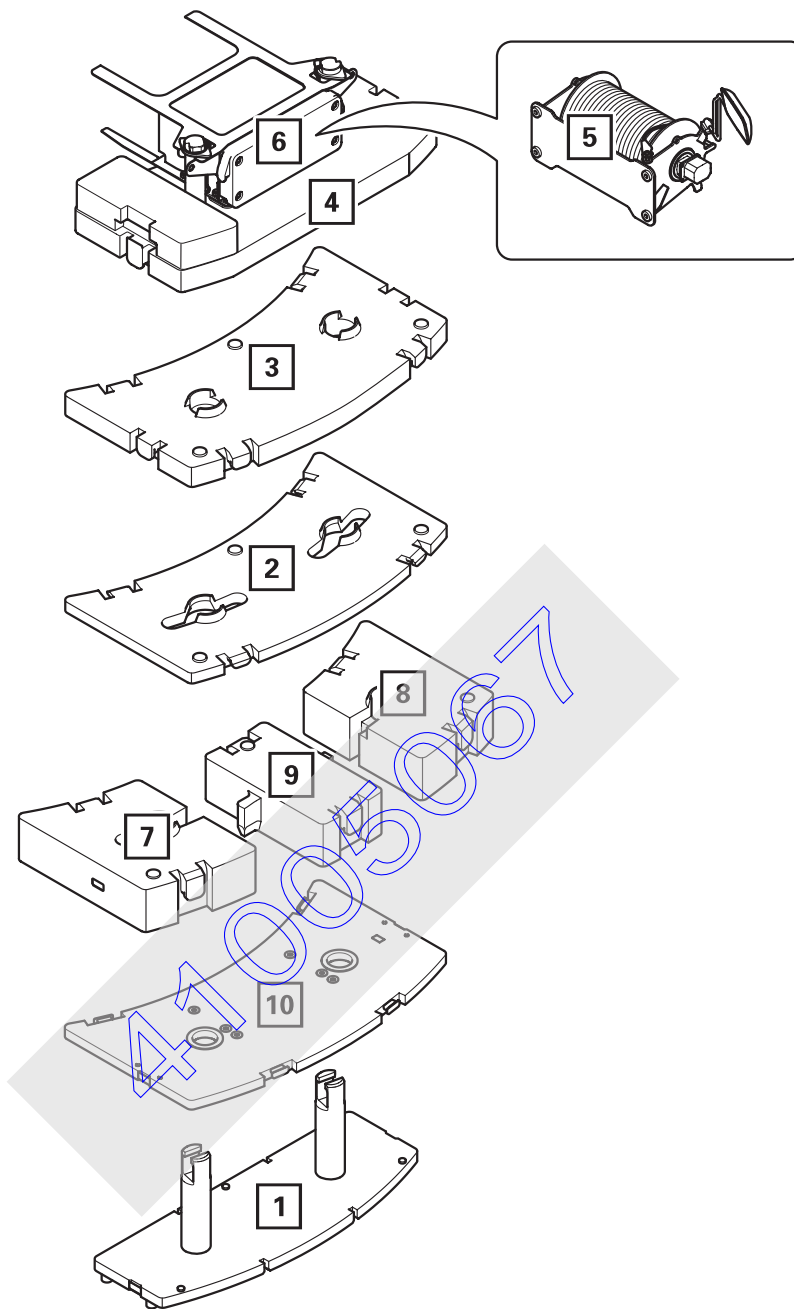

W12042

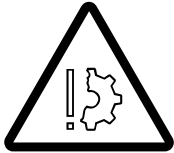

Risk of damage to the lifting cylinders!

If necessary, mount the plate **3** or **10** on the turntable, so that the lifting cylinders do not knock against the assembled counterweight while slewing.

☛ *Version C*, p. 13 - 63.

Generally, plates **3** and **10** which have been set down must always be placed below the plates **7** and **8**.

Counterweight sections	Counterweight version in t (lbs)							
	19.5 (42 900)		21.7 (47 800)		23.9 (52 600)		26.1 (57 500)	
6.3 t on the turntable	4 + 6 or 4 + 5							
4.4 t section	-	-	3	3 ¹⁾	3	3	3	3
3.3 t plates	7 8	7 8	7 8	7 8	7 8	7 8	7 8	7 8
2.2 t section	9 2 ²⁾	2 10	-	9	2 ²⁾	9 2 ²⁾	2 10	9 2 10
2.2 t base plate	1	1	1	1	1	1	1	1

1) For **3**, **2** + **10** can also be used

2) For **2**, **10** can be used

13.7.7 counterweight hoist unit

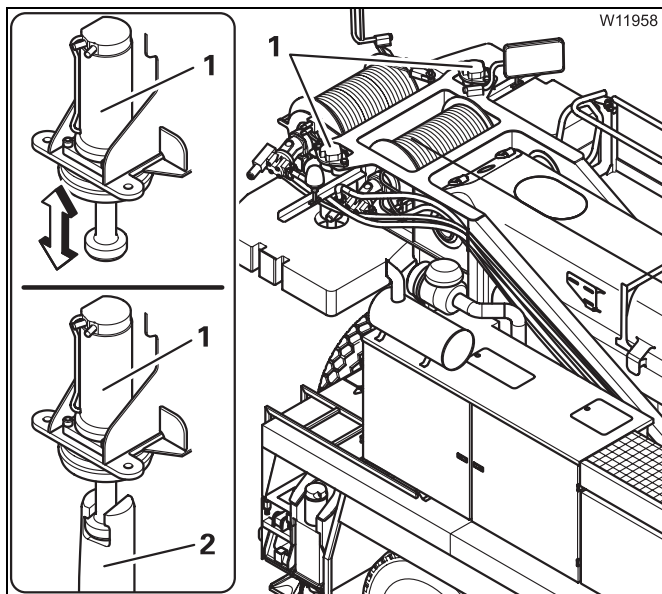

The lifting cylinders (1) can be extended and retracted.

To lift and lower the counterweight, the lifting cylinders are screwed into the 2.2 t base plate (2).



Risk of crushing when raising and lowering.

Make sure nobody is on the counterweight platform while the counterweight is being lifted or lowered.

Before raising or lowering, remove all objects which could become trapped or crushed, and fold in the slinging points on the 2.2 t base plate.

Counterweight submenu

To operate the counterweight hoist unit, you must open the *Counterweight* submenu.

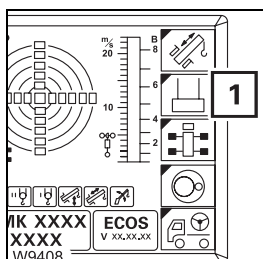

Opening the submenu

- If necessary, open the main menu **Esc** and press the button (1) once.

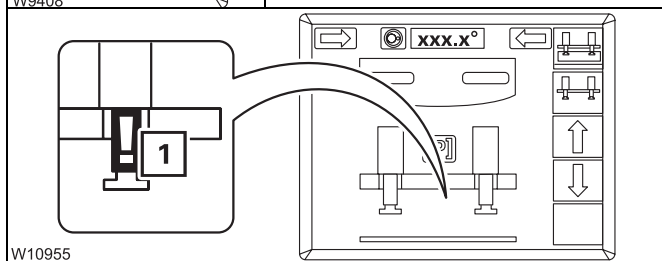

The *Counterweight* submenu opens.

If an error symbol (1) is displayed with subsequent operation, please contact **CraneCARE**.

Extending / retracting the lifting cylinders

This section describes how to operate the lifting cylinders manually,
– for correcting the displayed rigging mode and
– for pre-charging the counterweight afterwards.



Always lift and lower the counterweight in automatic mode, otherwise slewing with extended lifting cylinders will be blocked; *Automatic mode, rigging*, p. 13 - 74, *Automatic mode, unrigging*, p. 13 - 75.

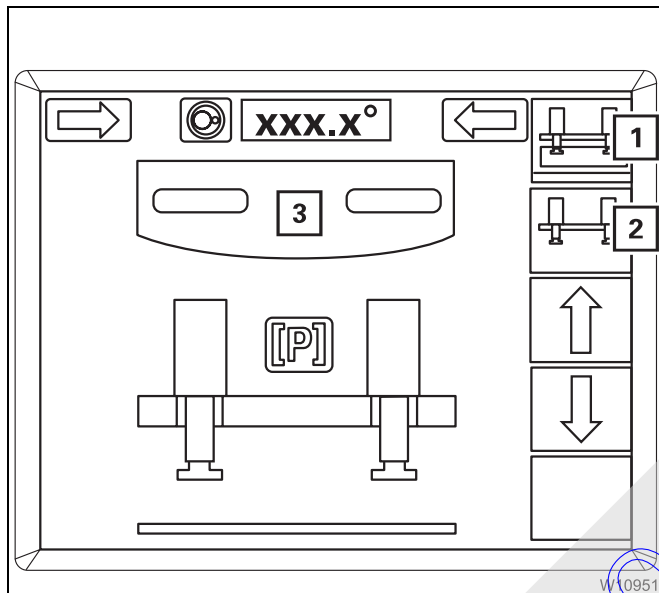

Correct the rigging mode

- You can only use the automatic mode if the current rigging mode is displayed.
 - 1 yellow – counterweight rigged
 - 2 yellow – counterweight unrigged

If necessary, correct the displayed rigging mode as follows:

- Slew the superstructure out of the rigging range – display (3) – so that the lifting cylinders can be freely extended.

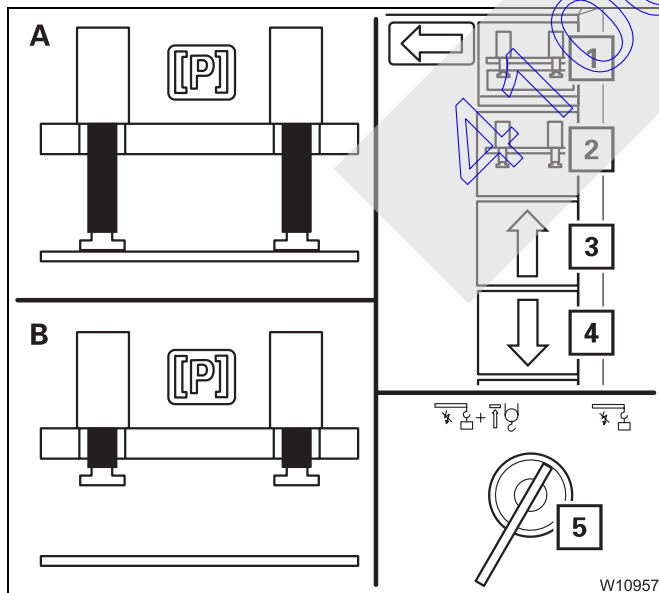

If the symbol (1) is yellow with the counterweight unrigged:

- Turn the key-operated switch (5) to the right.
- (A) Fully extend the lifting cylinders – button (4).
- Let go of the key-operated switch (5).
- (B) – Fully retract the lifting cylinders – button (3).

The symbol (2) turns yellow – counterweight unrigged.

You can now use the automatic mode.



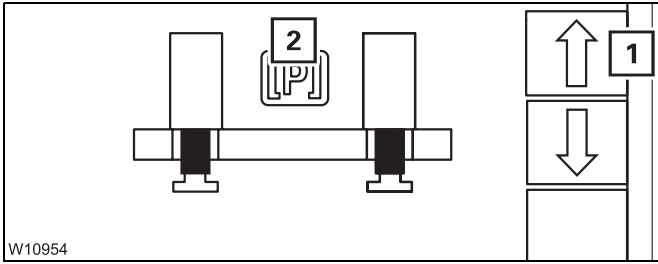

Pre-tensioning

When the symbol (2) is **red**, you must pre-tension the counterweight.

- Press the button (1) until the symbol (2) turns **green**.

Automatic mode, rigging

While the automatic process is being performed, you can always

- **cancel** the automatic process; *Cancel automatic mode*, p. 13 - 76.
- **interrupt** the automatic process by letting go of the control lever. After moving the lever in the displayed direction once more, the automatic process is continued.

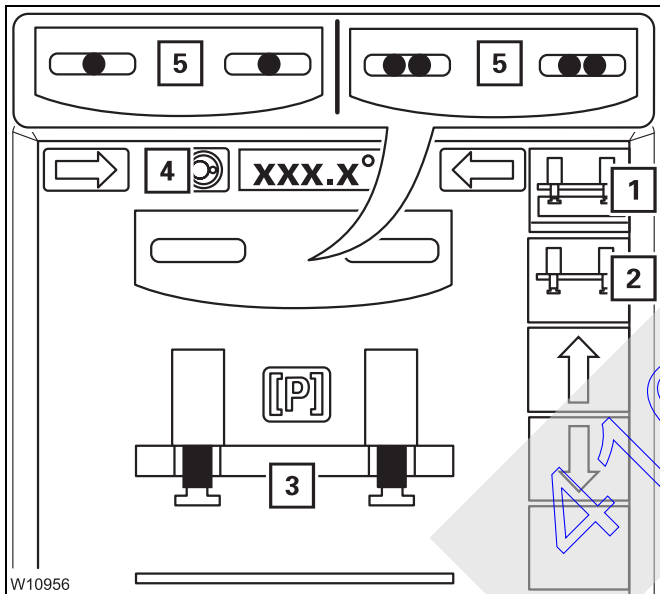

Prerequisites

- The counterweight version has been assembled.
- The slinging points on the 2.2 t base plate have been folded in.
- The symbol (2) is **yellow**. If the symbol (1) is yellow; *Correct the rigging mode*, p. 13 - 73.
- The lifting cylinders are fully retracted – display (3).
- The slewing gear is switched on – symbol (4) **green**.
- The superstructure is in the rigging range – one display (5) **green**.

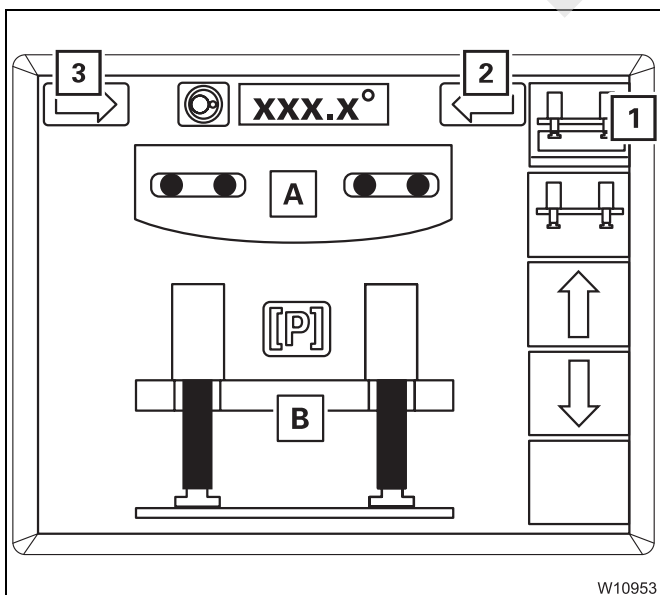

Switch on automatic mode

- Press the button (1) once – the symbol flashes.

Perform automatic process.

- To slew, move the control lever in the displayed direction (2) or (3) – the automatic process starts.
 - The superstructure turns into position (A).
 - The lifting cylinders are extended (B).
- Let go of the control lever.

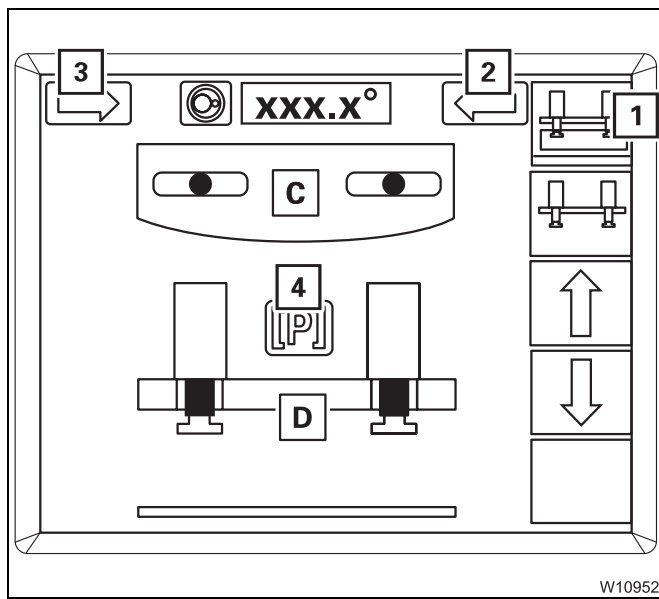

- To slew, move the control lever in the displayed direction (2) or (3) – the automatic process continues.
 - The superstructure turns into position (C).
 - The lifting cylinders are retracted (D).
 - The counterweight is pre-charged – symbol (4) **green**.
- The symbol (1) is yellow and no longer flashes, the rigging process is complete.
- Let go of the control lever.

Automatic mode, unrigging

While the automatic process is being performed, you can always

- **cancel** the automatic process;  *Cancel automatic mode*, p. 13 - 76.
- **interrupt** the automatic process by letting go of the control lever. After moving the lever in the displayed direction once more, the automatic process is continued.

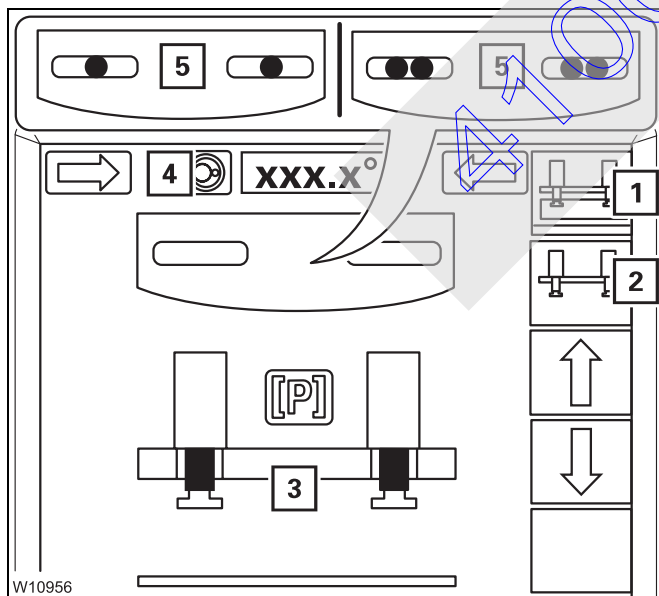

Prerequisites

- The symbol (1) is **yellow**. If the symbol (2) is yellow;  *Correct the rigging mode*, p. 13 - 73.
- The lifting cylinders are fully retracted – display (3).
- The slewing gear is switched on – symbol (4) **green**.
- The superstructure is in the rigging range – one display (5) **green**.



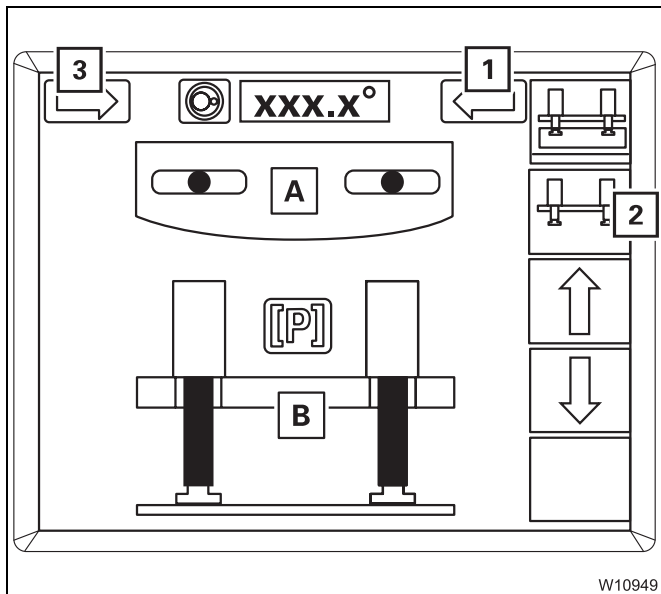

Switch on automatic mode

- Press the button (2) once – the symbol flashes.

Perform automatic process.

- To slew, move the control lever in the displayed direction (1) or (3) – the automatic process starts.
 - The superstructure turns into position (A).
 - The lifting cylinders are extended (B).
- Let go of the control lever.

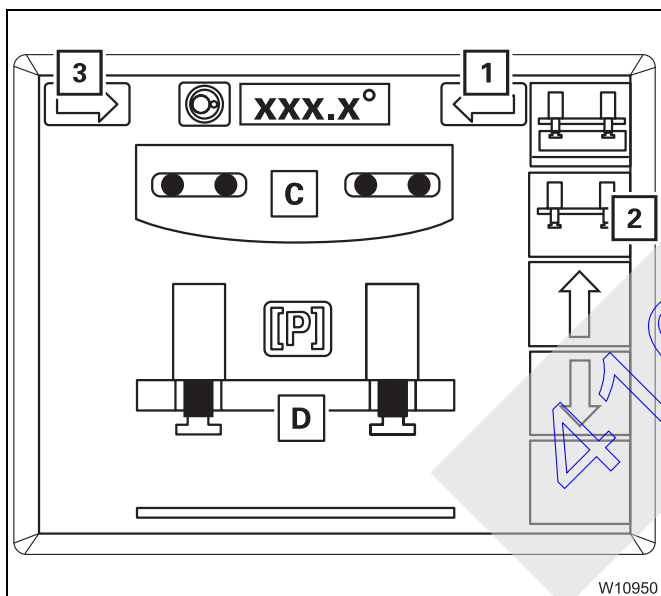

- To slew, move the control lever in the displayed direction (1) or (3) – the automatic process continues.
 - The superstructure turns into position (C).
 - The lifting cylinders are retracted (D).
- The symbol (2) is yellow and no longer flashes, the rigging process is complete.
- Let go of the control lever.

Cancel automatic mode

You can cancel the automatic process any time.

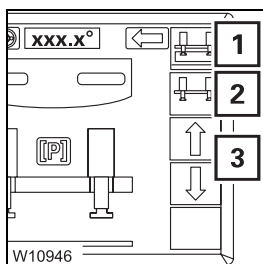

- Press the button not used (1), (2) or a button (3)
The automatic process is cancelled.

If the symbol (1) or (2) is **yellow**, you can re-activate the automatic process.

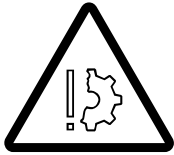

Risk of damage to the counterweight

With the key-operated switch actuated, the functions are always released. Never move the lifting cylinder to the *Intermediate position* rigging range. Only slew the superstructure when the lifting cylinders are fully extended (or fully retracted).

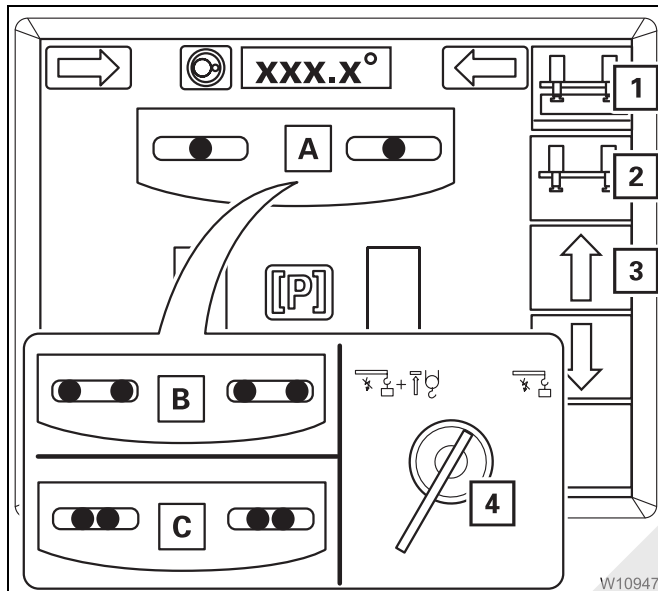

If the symbols (1) and (2) are **grey**, you must retract the lifting cylinders:

In the event of position (A) or (B)

- Fully retract the lifting cylinders – button (3).

In the event of position on display (C)

- Turn the key-operated switch (4) to the right. The following movements are now no longer monitored.
- Slew the superstructure to position (A) or (B) – caution: no monitoring.
- Fully retract the lifting cylinders.

13.7.8

Removing / installing the counterweight on the turntable

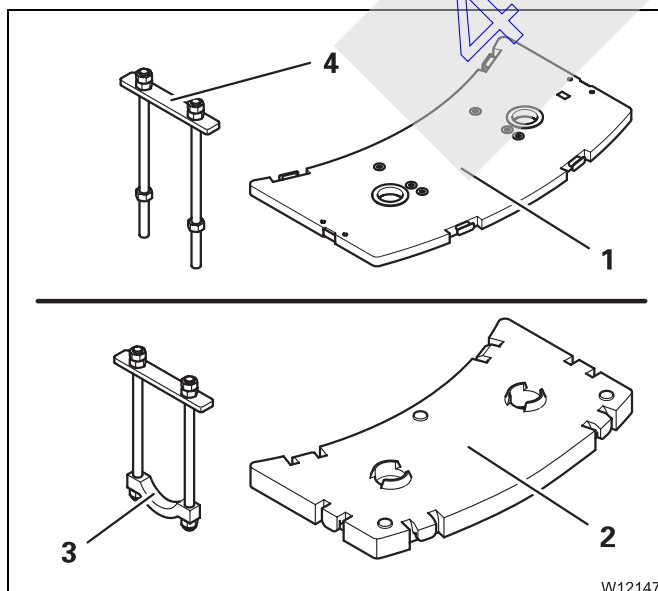

With version **C** the 2.2 t plate (1) or the 4.4 t plate (2) can be mounted on the turntable.

- Two clamps (4) are provided for the plate (1).
- Two brackets (2) are also provided for the plate (3).

In order to lift the plates, you will require suitable lifting gear, e.g. a forklift truck.



Mounting

Before you mount a plate on the turntable, you must unrig the remaining counterweight (with Automatic mode).



Risk of damage to the lifting cylinders!

Always unrig the remaining counterweight before you mount or remove a plate. This prevents the lifting cylinders from knocking against the counterweight which has been stacked too high during slewing.

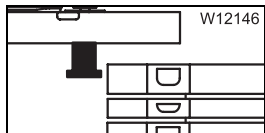

When you stack the plate onto the counterweight, the lifting cylinders will be damaged while slewing; p. 13 - 63.

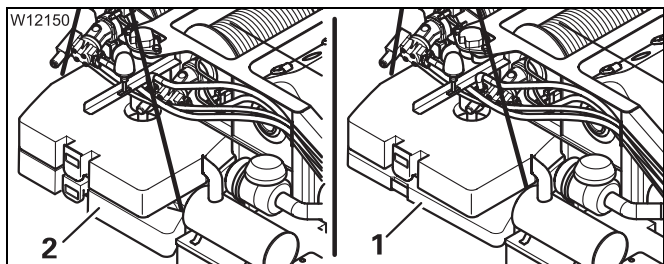

Lifting the plate

- Lift the plate (1) or (2) onto the turntable; *Slings points*, p. 13 - 58.
- Align the connection points.

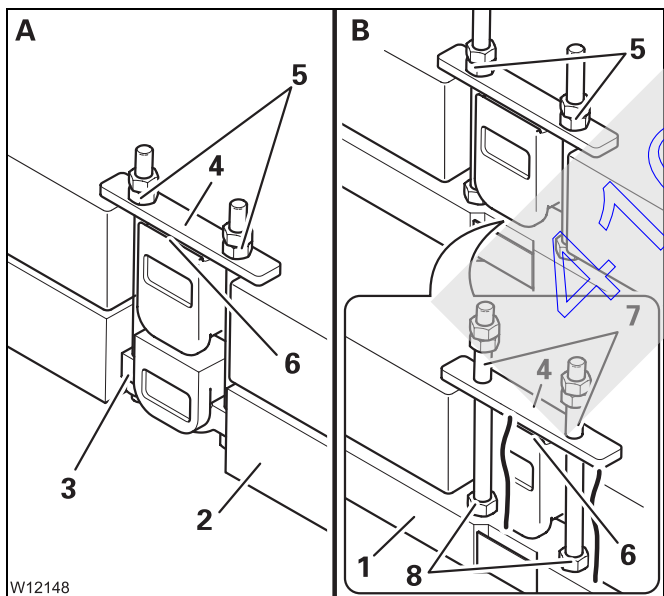

- (A) – 4.4 t plate:
Suspend the bracket (3) in the plate (2) from below. Fold the clamp (4) behind the slinging point (6) at the top.
- (B) – 2.2 t plate:
Place the clamp (4) behind the slinging point (6). Turn the rods (7) up to their lower edge into the plate (1) and secure them with the nuts (8).
- Tighten the nuts (5) with 100 Nm (74 lbf ft) and secure them with the counter nuts.
- Secure the clamp on the other side in the same way.

Removing

Before you remove a plate from the turntable, you must unrig the remaining counterweight (with Automatic mode).

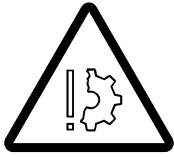

Risk of damage to the lifting cylinders

Always unrig the remaining counterweight before you mount or remove a plate. This prevents the lifting cylinders from knocking against the counterweight which has been stacked too high during slewing.

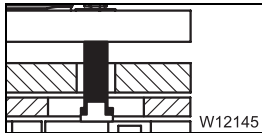

If you lower the plate together with the counterweight, the lifting cylinders will be damaged while slewing; p. 13 - 63.

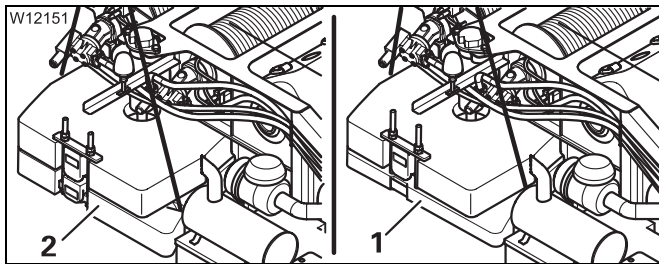

Securing the plate

- Secure the mounted plate (1) or (2) using suitable lifting gear; *Slings points*, p. 13 - 58.

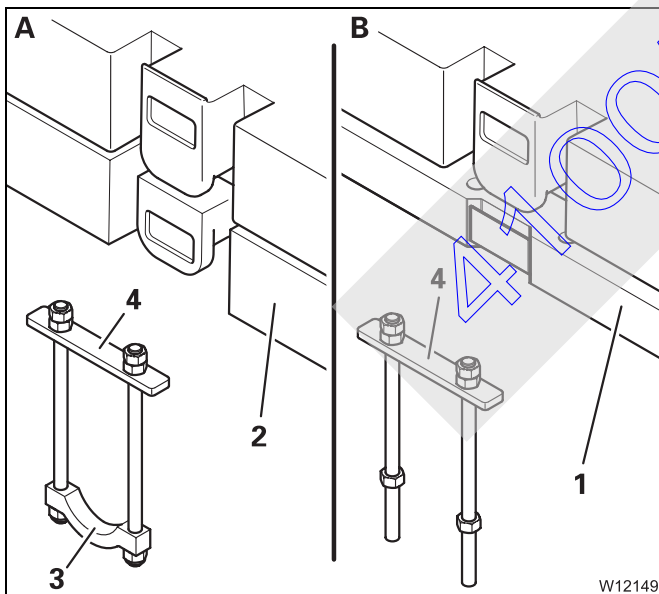

- (A) – 4.4 t plate:
Unscrew the nuts and remove the clamp (4) and the bracket (3).
- (B) – 2.2 t plate:
Unscrew the nuts and remove the clamp (4).
- Remove the clamp on the other side as well.
- Lift the plate (1) or (2) off the turntable.

13.7.9

Setting down counterweight for driving the truck crane

Which parts of the counterweight sections can be transported on the turntable and counterweight platform when driving the truck crane depends on the driving mode of the truck crane;  *Driving modes*, p. 6 - 1.



Danger of accidents due to the counterweight slipping or tipping over

Place only the 2.2 t base plate directly onto the counterweight platform; In this way you prevent the counterweight from slipping.

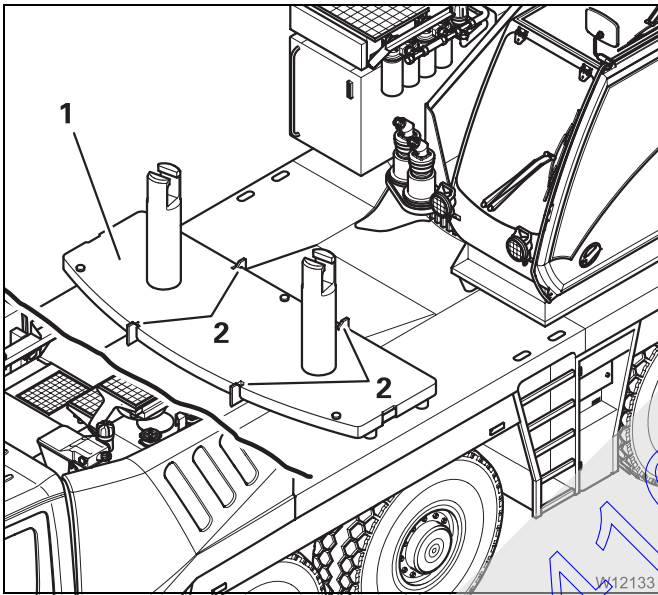

Only the 2.2 t base plate (1) may be set down directly on the counterweight platform.

Other sections are not secured by the retaining sheets (2) and cannot be set down in a flat position.



Risk of damage to the derricking cylinder

Always check whether the specifications in this section apply before setting down the main boom.

In this way you can prevent the derricking cylinder from being pushed against an incorrectly assembled counterweight combination and becoming damaged.

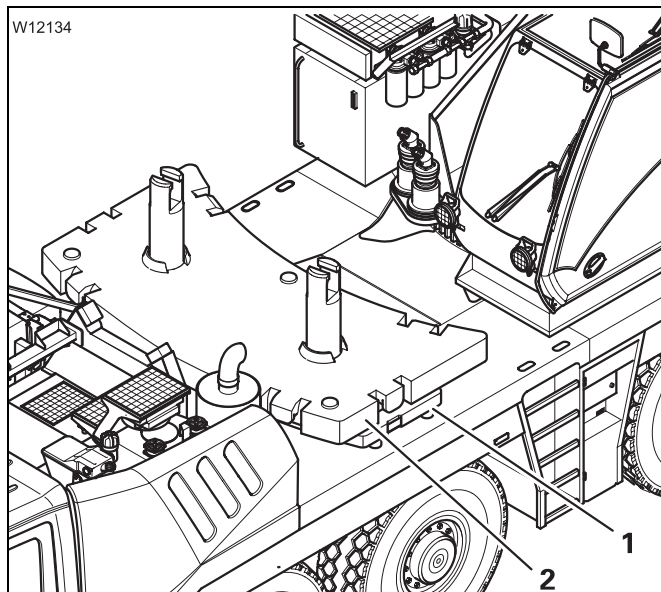

- Observe the following points to avoid damage to the derricking cylinder.

For version A and B

- At most, set
 - the 2.2 t base plate (1) and
 - the 4.4 t plate (2) down.

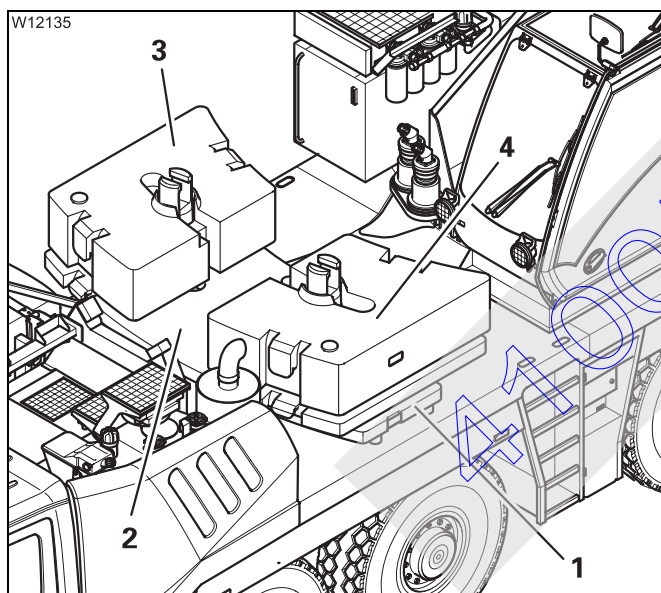

With version C

- At most, set
 - the 2.2 t base plate (1) and
 - one 2.2 t plate (2) down.

You can also set the die 3.3 t plates (3) and (4) onto the plate (2).

13.7.10

Slewing with rigged counterweight

Slewing with a rigged counterweight is only permissible when:

- The necessary outrigger span is rigged
- The respective SLI code is shown and
- The permissible working radius according to *Lifting capacity table* is maintained



Danger of overturning when slewing with an incorrectly set SLI

Always check before slewing whether the SLI code valid for the current rigging mode is displayed.

This prevents slewing operations from being released within impermissible ranges, which would cause the truck crane to overturn.



Risk of overturning when operating with the hand-held control

When operating with the hand-held control, there is no monitoring by the SLI. Before slewing, always check using the following table whether slewing is permissible.

This prevents the truck crane from overturning while rotating.

41005067

		Rigged outrigger span 8.332 x (27.3 x)					Free on wheels	
		2.54 m (8.4 ft)	4.00 m (13.2 ft)	5.00 m (16.4 ft)	6.00 m (19.6 ft)	7.00 m (23.0 ft)		
Rigged counterweight	4.1 t (9,000 lbs)	1)	Slewing permissible					Slewing not permissible ²⁾
	6.3 t (13,800 lbs)							
	8.5 t (18,700 lbs)							
	10.7 t (23,500 lbs)							
	12.9 t (28,400 lbs)							
	15.1 t (33,200 lbs)							
	17.3 t (38,100 lbs)							
	19.5 t (42,900 lbs)							
	21.7 t (47,800 lbs)							
	23.9 t (52,600 lbs)							
26.1 t (57,500 lbs)	Rigging modes not permissible							

- 1) Slewing only permitted if the radius permitted in the working range is observed (at least 3.0 m (9.8 ft));  *Lifting capacity table*
- 2) Only 0° working range to the rear permitted,

Blank page

41005067

13.8 Rigging work on the main boom

13.8.1 Hook block on the bumper

Picking up the hook block

Depending on the driving mode, you must pick up the hook block from the front bumper;  *Driving modes*, p. 6 - 1.



Danger of accidents if the view is obstructed

Have someone instruct you when raising the main boom, since the view on the hook block is obstructed. That way you will not raise the boom too far, which would cause the retaining rope to tear.

The main boom is fully retracted.

- Enter the current rigging mode on the SLI.

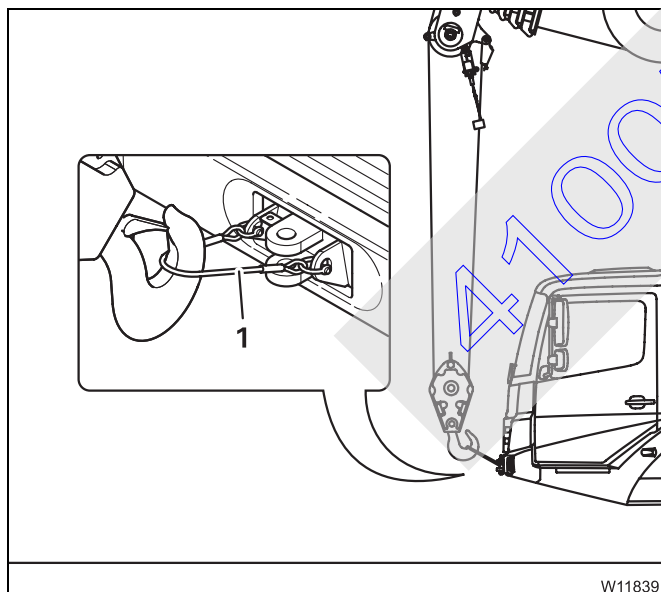
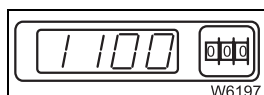

- Slacken the hoist rope and raise the main boom simultaneously.
- Raise the main boom until the boom head is in a vertical position above the hook block.
- Detach the hook block from the retaining rope (1).



Attaching the hook block

Depending on the driving mode, you can attach the hook block to the front bumper;  *Driving modes*, p. 6 - 1.



Danger of accidents if the view is obstructed

The reeved rope lines obstruct the view on the road. The number of legally permissible rope lines can vary depending on the country in which you are working. According to EU regulations, the hook block may not be reeved more than four times when driving on the road.



Danger of accidents due to the hook block swinging unexpectedly

The hook block will suddenly swing **forwards** if the retaining rope for the hook block tears when tightening the hoist rope.

Therefore make sure that the banksman or other persons are always at a safe distance **to the side** of the hook block.



Do not attach the rope end clamp to the front towing coupling. The towing coupling must be free for a tow-rod in emergencies.

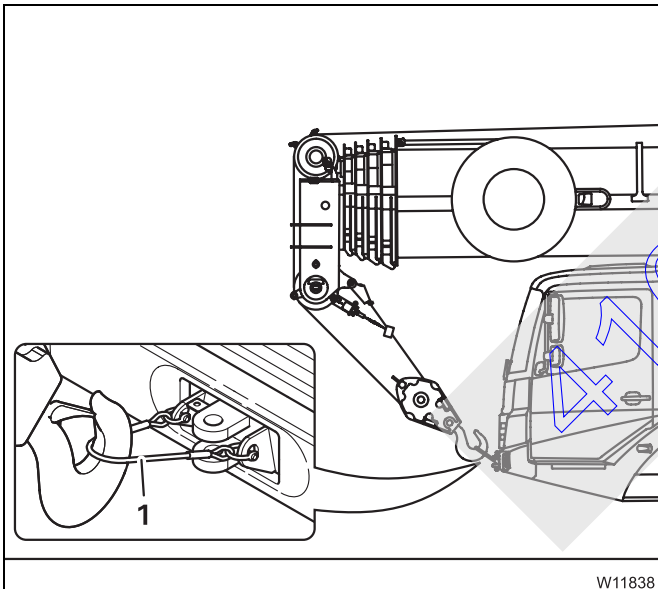

- Raise the hook block vertically above the retaining rope (1).
- Lower the hook block and attach the hook block to the retaining rope (1).
- Set down the main boom onto the boom rest and pull the hoist rope tight only to the extent that the hook block is stabilized in its position.



If the lifting limit switch is deactivated while you tighten the hoist rope, you can override the deactivation of the lifting limit switch;  p. 12 - 52.

13.8.2

Hook block on a separate vehicle



Risk of overturning while slewing

Always check before slewing whether slewing is permitted in the truck crane's current rigging mode. Correct the rigging mode if necessary;
▮▮▮▮▶ *Slewing with rigged counterweight*, p. 13 - 82.



Danger of overturning when slewing with an overridden SLI

Do not override the SLI before slewing the superstructure.
Enter an SLI code for the 360° working range if the slewing operation is not released.
In this way you prevent the superstructure from being slewed into impermissible areas and the truck crane tipping over as a result.



Risk of damage to the separate vehicle

Only raise the hook block from the separate vehicle if the main boom head is directly above the hook block.
This prevents the hook block from swinging and damaging the separate vehicle.



Risk of damage to the hoist rope

To prevent slack rope, do not ease down too much hoist rope when picking up and reeving the hook block.
Slack rope causes rope loops on the hoist drum, which can result in the load slipping and the hoist rope being destroyed.



**Hook block
(picking up)**

Depending on the driving mode, the hook block can be placed on a separate vehicle;  *Driving modes*, p. 6 - 1.

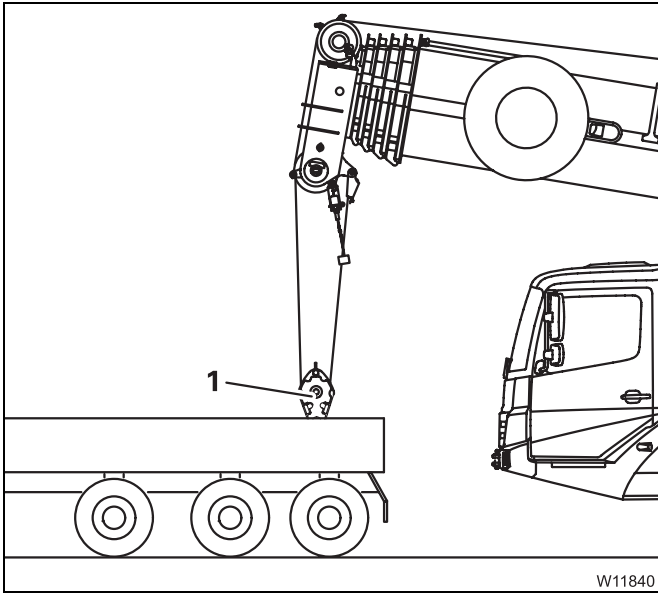

- If the respective setting has been made in the SLI, slew the superstructure and lower the main boom until the boom head is directly above the hook block (1).
- Unreel the hoist rope.
- Reeve the hoist rope into the hook block (1);  *Reeving and unreeling the hoist rope*, p. 13 - 90.
- Raise the hook block off the separate vehicle.

**Hook block
(setting down)**

Depending on the driving mode, the hook block must be placed on a separate vehicle;  *Driving modes*, p. 6 - 1.

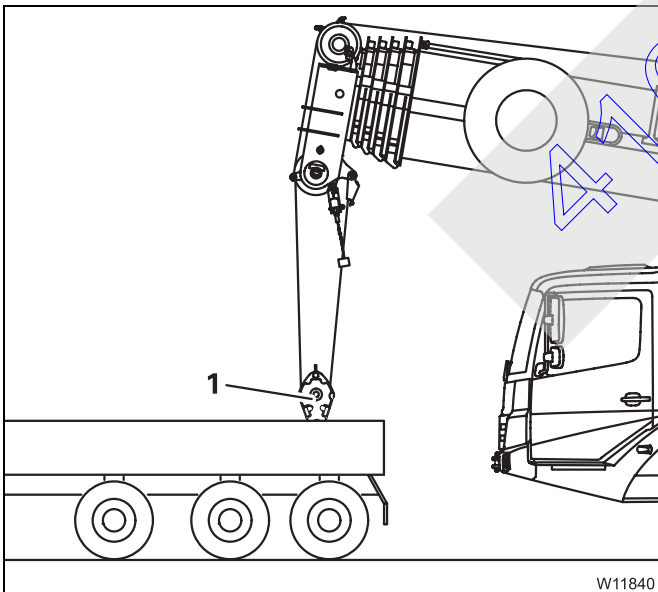

- With the SLI set accordingly, fully retract the main boom.
- Raise the hook block until it is about 1 m (3.3 ft) below the main boom.
- Lower the main boom and set the hook block (1) down on the separate vehicle.

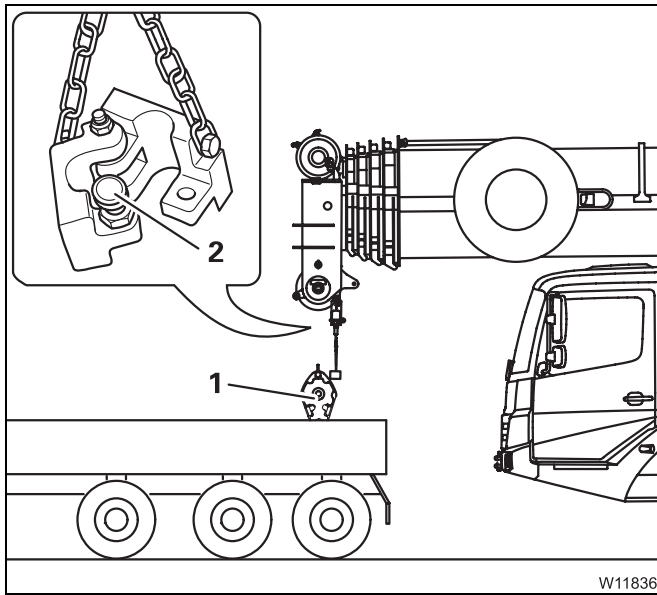

- Detach the lifting limit switch weight (2) from the hoist rope; ►► p. 13 - 105.
- Unreeve the hoist rope; ►► p. 13 - 95.
- Secure the hook block (1) for transport.
- Set down the main boom on the boom rest

Fastening the hoist rope to the bumper

Do not attach the rope end clamp to the front towing coupling. The towing coupling must be free for a tow-rod in emergencies.

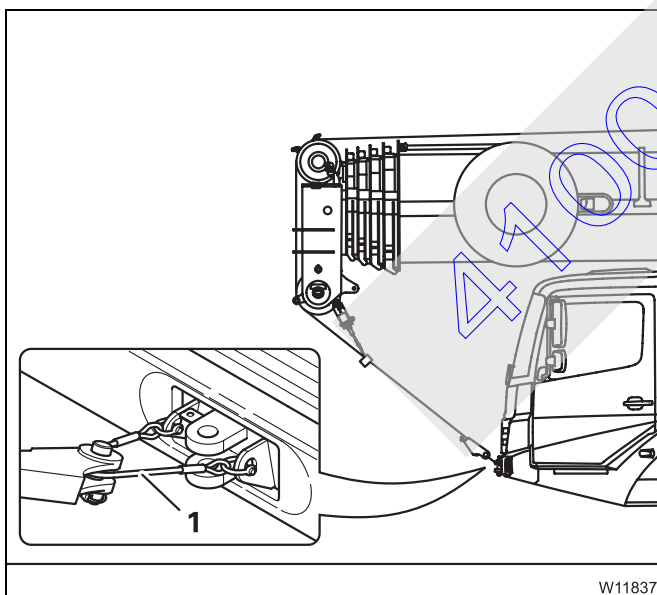

- Attach the rope end clamp to the retaining rope (1).
- Pull the hoist rope slightly taut.
- Fasten the lifting limit switch weight to the hoist rope.

The hoist rope and lifting limit switch weight are now secured for driving.

13.8.3

Reeving and unreeving the hoist rope

You must reeve a certain number of rope lines, depending on the required lifting capacity. Four reeved rope lines correspond to 4-fall reeving, for example.

Possible reeving and the corresponding lifting capacities;  p. 13 - 96

Fastening the rope end clamp

The rope end clamp is used to fasten the hoist rope to the main boom head or the hook block after reeving.



Risk of accidents due to incorrect rope guide

Always thread the hoist rope through as shown in the section *Correct rope guide*.

This prevents the load-bearing rope from becoming kinked, which would damage it and make it tear.

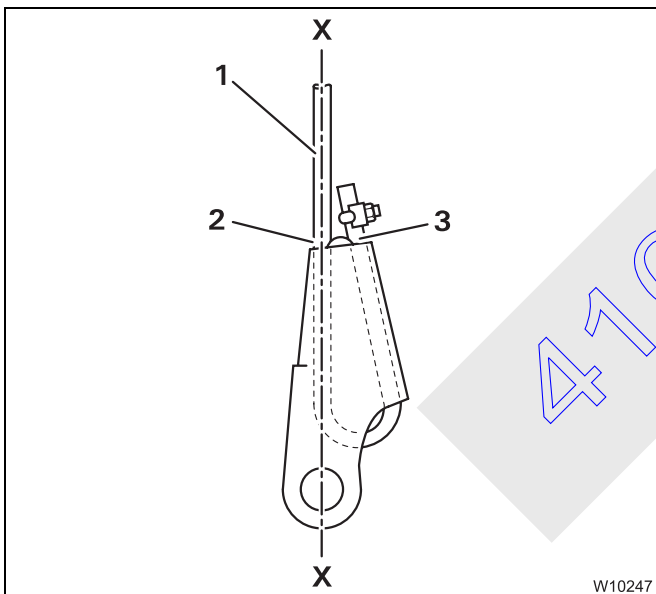

Correct rope guide

The hoist rope end must run into the rope end clamp at point (2) and protrude from the rope end clamp at point (3).

Under a load, the load-bearing rope (1) runs along the pulling axis (X-X) and is not kinked.

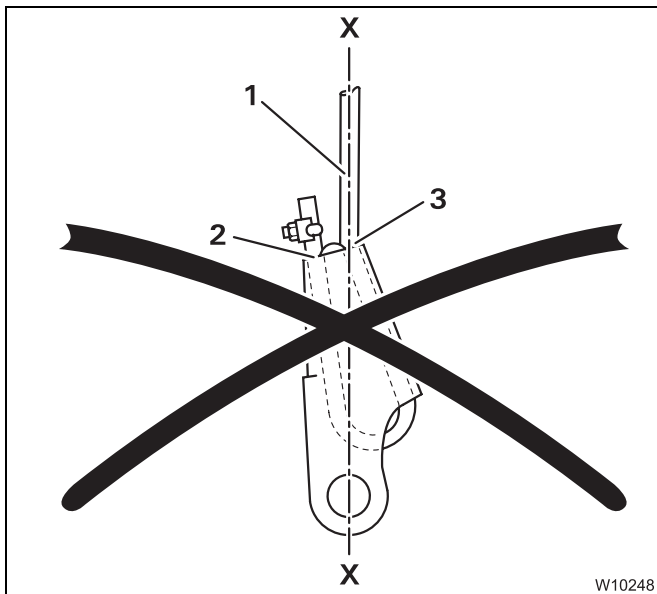

Incorrect rope guide

The hoist rope end must **never** run into the rope end clamp at point (3) and protrude from the rope end clamp at point (2).

Under a load, the load-bearing rope would become kinked at point (3) and become damaged as a result.

The rope end clamp and the rope wedge are marked with their size and the rope diameter they are designed for.



Risk of accidents from incorrect rope end clamp / rope wedge

Only use rope end clamps and rope wedges of the same size that are designed for the cross-section of the hoist rope you are using. This will prevent the hoist rope from slipping out of the rope end clamp when under a load, which would cause the load to be dropped.

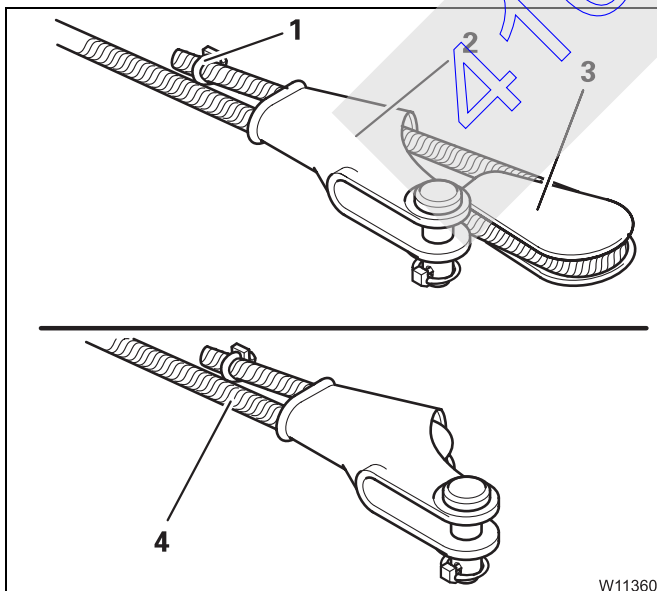

- Observe the correct rope guide.
- Insert the hoist rope with the corresponding rope wedge (3) into the rope end clamp (2).
- Fasten the rope clamp (1) to the loose end of the hoist rope.
- Pull the hoist rope (4) taut until the rope wedge and the hoist rope sit tightly in the rope end clamp.



Reeving the hoist rope

Reeving is also possible when the rope end clamp is fastened.



Danger posed by rope slack

Only use hook blocks and sling gear of the minimum weight prescribed in the *Lifting capacity table*, depending on the reeving and boom length. That way you prevent slack rope forming at large heights when lifting without a load. This can result in the load slipping.

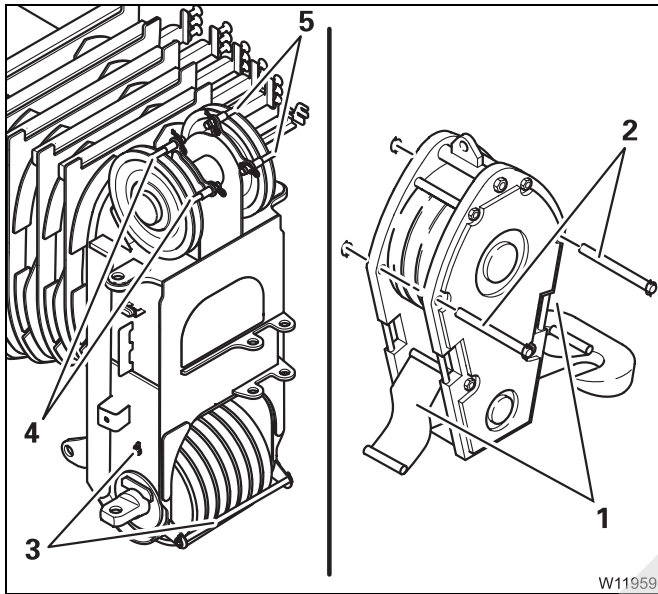

Opening the hook block

- Pull out the rods (2).
- Fold down the plates (1).

Positioning the hoist rope

- Pull out the rods (3).
- Pull out the rods (4) for the **main hoist rope**.
- Pull out the rods (5) for the **auxiliary hoist rope**.

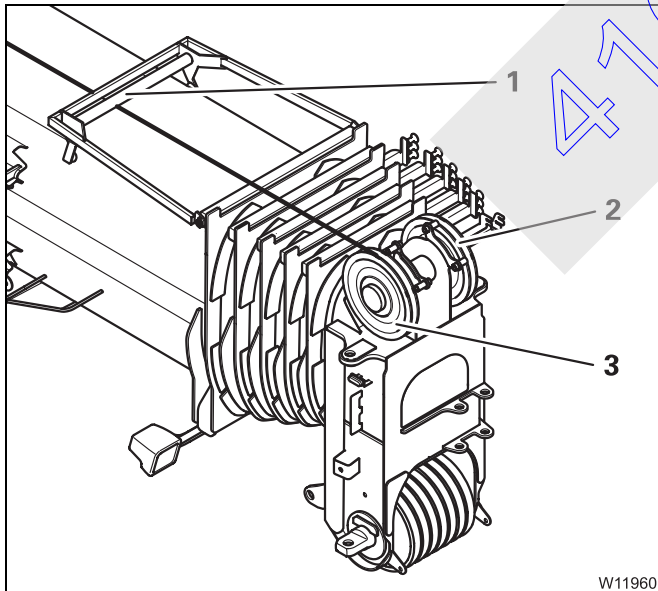

- Guide the hoist rope through under the rope grab (1).

If two hoist ropes are reeved, you must feed the auxiliary hoist rope **over** the rope grab.

- Feed the main hoist rope to the head sheave (3).
- Feed the auxiliary hoist rope to the head sheave (2).

Use the rope grab also when operating the lattice extension.

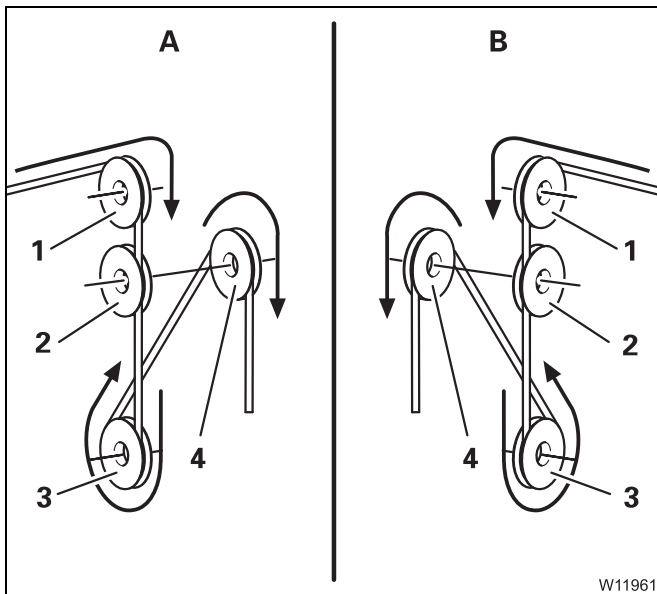

Reeving the hoist rope

- A** for the main hoist rope
- B** for the auxiliary hoist rope

- Guide the hoist rope over the upper head sheave (1) to the lower head sheave (2).
- Guide the hoist rope from the front around the outer pulley (3) of the hook block, upwards to the main boom head.
- Guide the hoist rope from the rear over the next required head sheave (4) etc.
- Reeve the hoist rope with the required number of lines.

Possible reevings; p. 13 - 96.

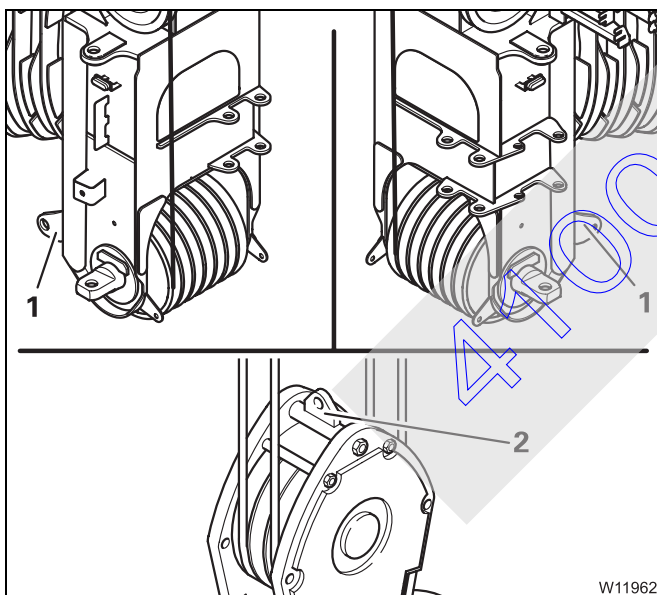

Fastening the hoist rope

The fixed point used depends on the number of reeved rope lines.

- **Fixed point for an even number of lines**
The rope end clamp is fastened to the fixed point (1) with 2-fall, 4-fall, 6-fall etc. reevings.
- **Fixed point for an odd number of lines**
The rope end clamp is fastened to the fixed point (1) with 2-fall, 3-fall, 5-fall etc. reevings.



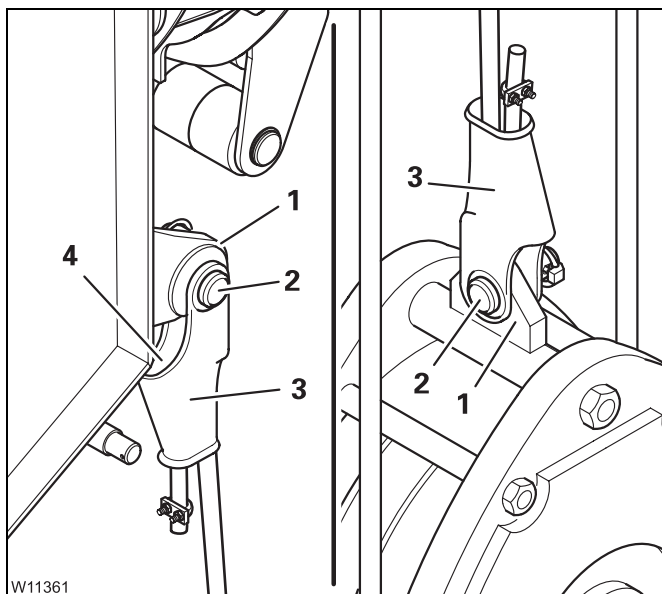

- Fit the rope end clamp (3) onto the fixed point (1). When the number of lines is even, the cutout (4) must point to the front.
- Attach the rope end clamp with the pins (2).
- Secure the pin using the linchpin.

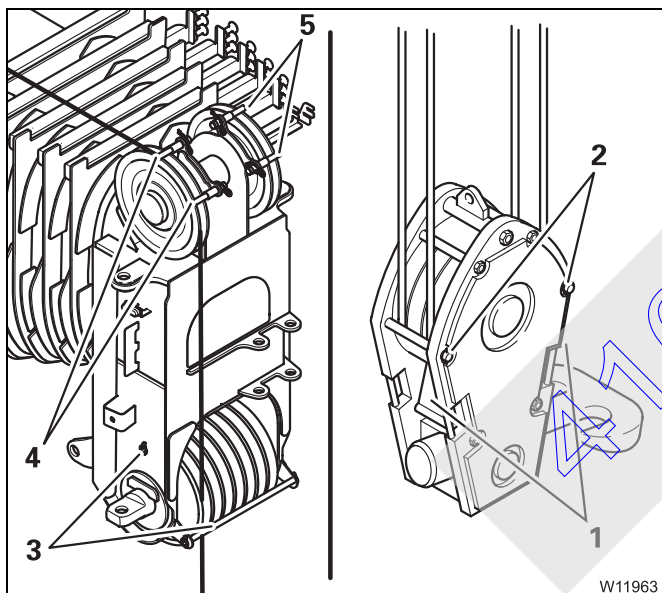

Securing the hoist rope

- Insert the rods (3) and (4), (5).
- Secure all rods using the retaining pins.

Closing the hook block

- Fold up the plates (1) on both sides.
- Insert the rope pins (2) and secure them with the linchpins.

Hoist rope (unreeving)

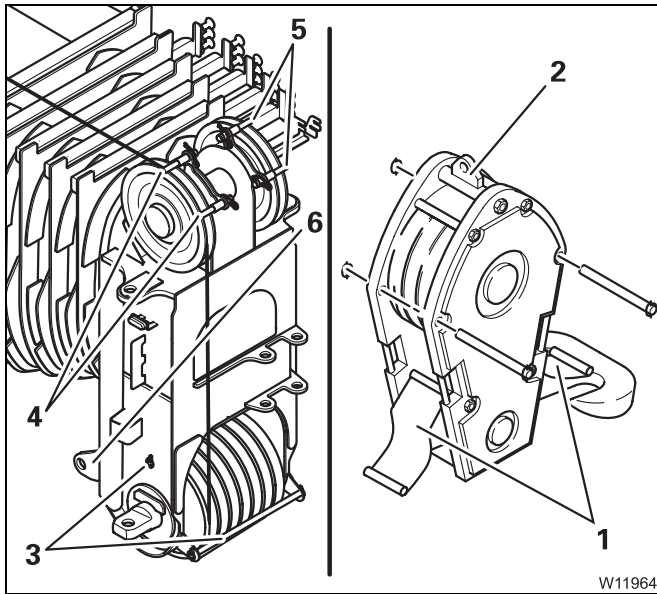

- Remove the retaining pins and pull out the rods (3).
- Fold down the plates (1);  p. 13 - 92.
- Remove the rope end clamp from the fixed point (2) or (6).
- Unreeve the hoist rope.

Depending on the driving mode, you can:

- fasten the hoist rope to the bumper;
 p. 13 - 89 or
- pull out the rods (4) and (5) and roll the hoist rope onto the drum.

41005067

13.8.4

Possible reeving methods on the main boom

Possible reeving on lattice extensions and the auxiliary single-sheave boom top;  *Operating Instructions Lattice Extension*.



The maximum lifting capacity of individual hook blocks does not correspond to the maximum lifting capacity of the GMK 4100 together with this hook block. The lifting capacity of the GMK 4100 depends on the rope pull, the reeving and friction force. It is lower than the lifting capacity of the hook block.



Please note that the maximum lifting capacities already include the weight of the hook block and the sling gear. You must subtract these weights in order to obtain the actual payload.

With 7 head sheaves

If 8 head sheaves are provided;  p. 13 - 99.

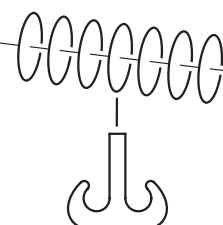

7 sheave hook block

Max. lifting capacity of the hook block 100 t (220,500 lbs)

Max. lifting capacity with the GMK 4100:

A With 14-fall reeving	77.0 t (169,800 lbs)
B With 13-fall reeving	71.7 t (158,100 lbs)
C With 12-fall reeving	66.3 t (146,200 lbs)

A

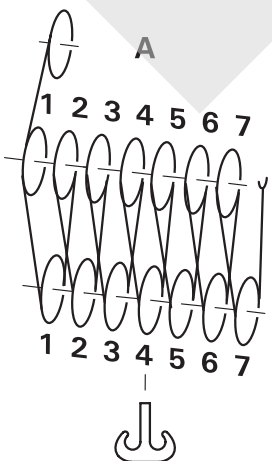

B

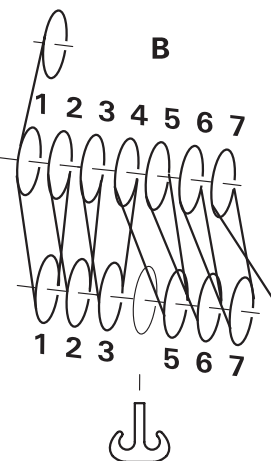

C

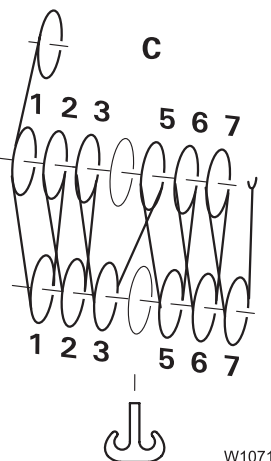

W10718

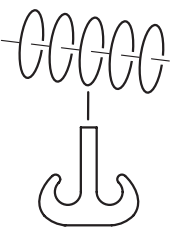

5 sheave hook block
 Max. lifting capacity of the hook block 63 t (138,900)
Max. lifting capacity with the GMK 4100:

A With 11-fall reeving	60.9 t (134,300 lbs)
B With 10-fall reeving	55.5 t (122,400 lbs)
C With 9-fall reeving	50.1 t (110,500 lbs)
D With 8-fall reeving	44.7 t (98,600 lbs)

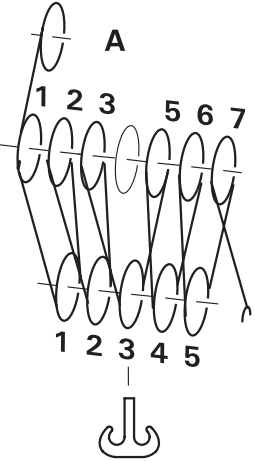
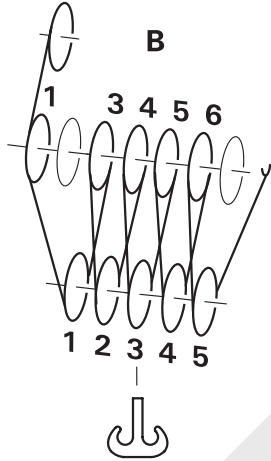
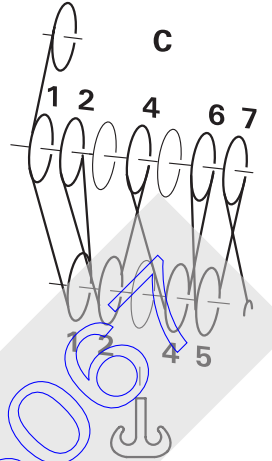
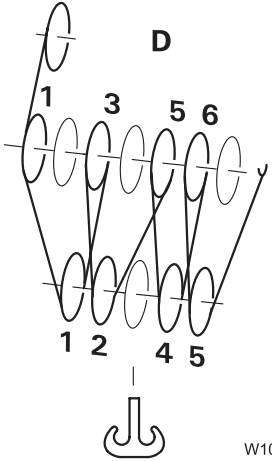



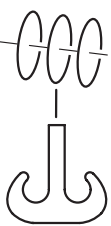

W10719

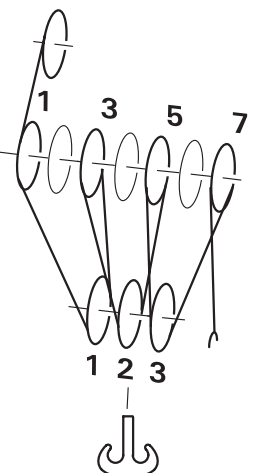
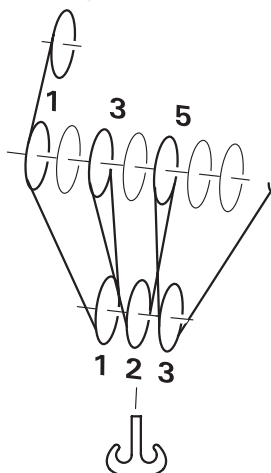
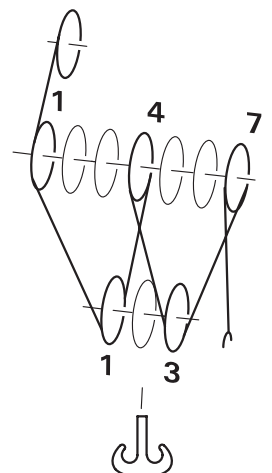
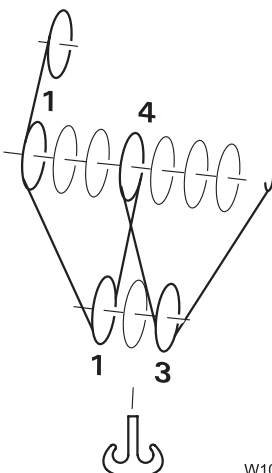

3 sheave hook block
 Max. lifting capacity of the hook block 40 t (88,200 lbs)
Max. lifting capacity with the GMK 4100:

A With 7-fall reeving	39.2 t (86,400 lbs)
B With 6-fall reeving	33.7 t (74,300 lbs)
C With 5-fall reeving	28.1 t (62,000 lbs)
D With 4-fall reeving	22.5 t (49,600 lbs)

W10722





1 sheave hook block

Max. lifting capacity of the hook block 20 t (44,100 lbs)

Max. lifting capacity with the GMK 4100:

- | | |
|------------------------------|---------------------|
| A With 3-fall reeving | 17.0 t (37,500 lbs) |
| B With 2-fall reeving | 11.3 t (24,900 lbs) |
| C With 1-fall reeving | 5.7 t (12,600 lbs) |

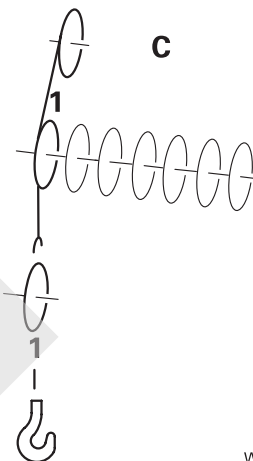
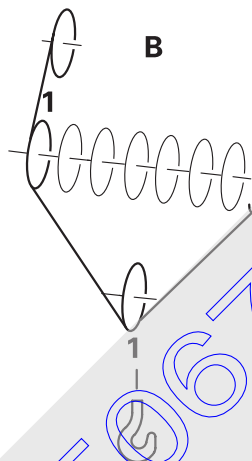
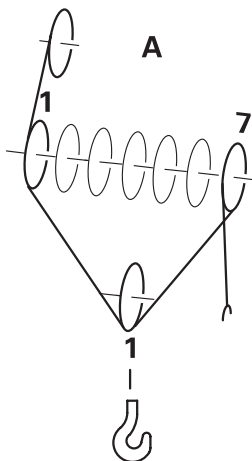

W10721



Hook tackle

Max. lifting capacity of the hook tackle 8 t (17,600 lbs)

Max. lifting capacity with the GMK 4100:

- | | |
|-------------------------|--------------------|
| A 1-fall reeving | 5.7 t (12,600 lbs) |
|-------------------------|--------------------|

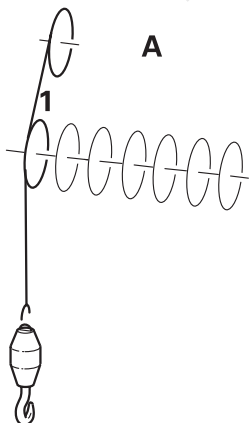

W10720

With 8 head sheaves

With additional equipment, 8 head sheaves may be provided. If 7 head sheaves are provided;  p. 13 - 96.

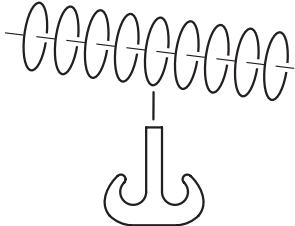

9 sheave hook block
Max. lifting capacity of the hook block 125 t (255,600 lbs)
Max. lifting capacity with the GMK 4100:

A With 16-fall reeving	85.0 t (187,400 lbs)
-------------------------------	----------------------

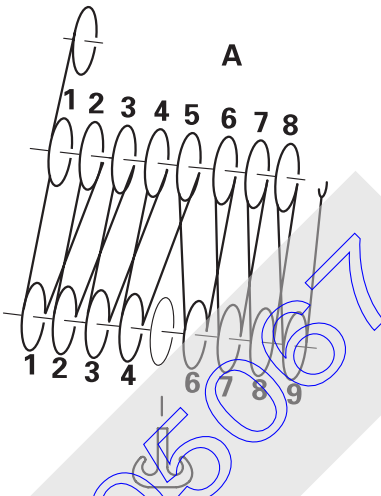

W11955

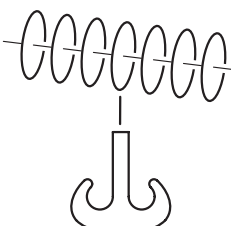

7 sheave hook block
Max. lifting capacity of the hook block 100 t (220,500 lbs)
Max. lifting capacity with the GMK 4100:

A With 15-fall reeving	82.3 t (181,400 lbs)
B With 14-fall reeving	77.0 t (169,800 lbs)
C With 13-fall reeving	71.7 t (158,100 lbs)
D With 12-fall reeving	66.3 t (146,200 lbs)

A

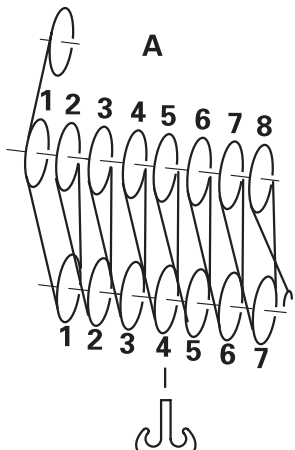

B

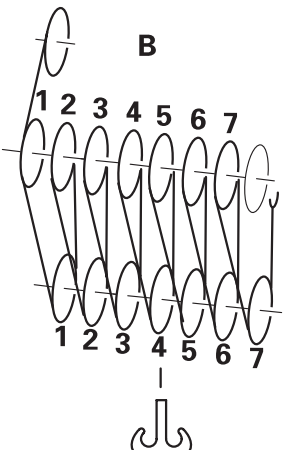

C

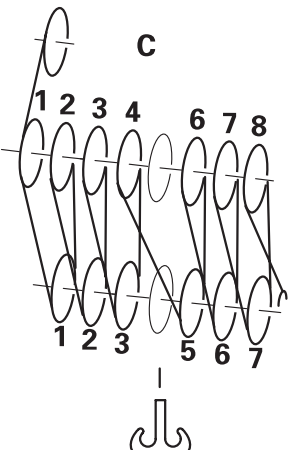

D

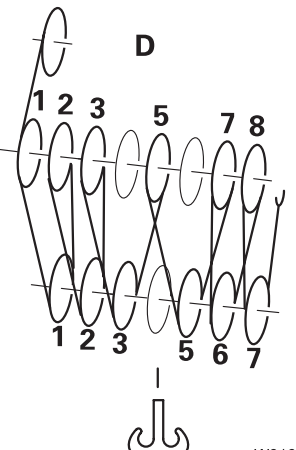

W3165



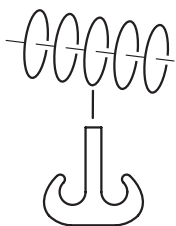

5 sheave hook block
 Max. lifting capacity of the hook block 63 t (138,900)
Max. lifting capacity with the GMK 4100:

A With 11-fall reeving	60.9 t (134,300 lbs)
B With 10-fall reeving	55.5 t (122,400 lbs)
C With 9-fall reeving	50.1 t (110,500 lbs)
D With 8-fall reeving	44.7 t (98,600 lbs)

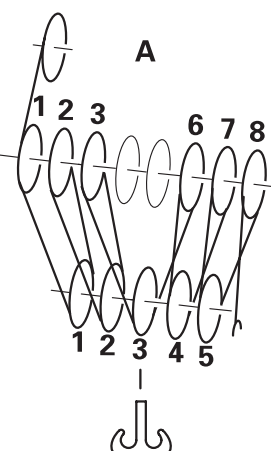
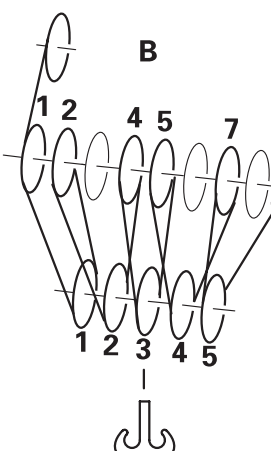
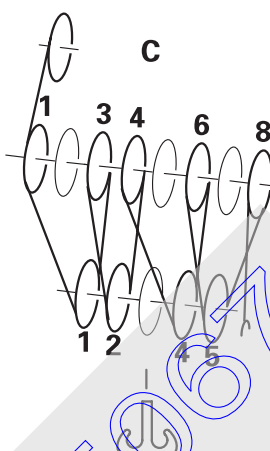
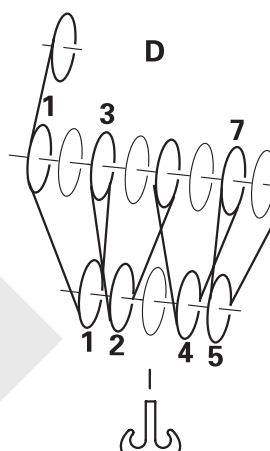





W3166

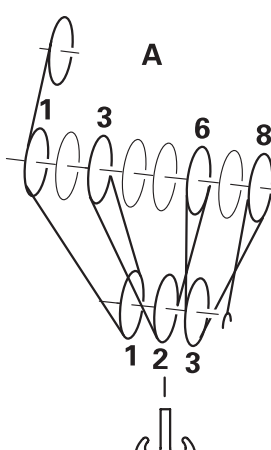
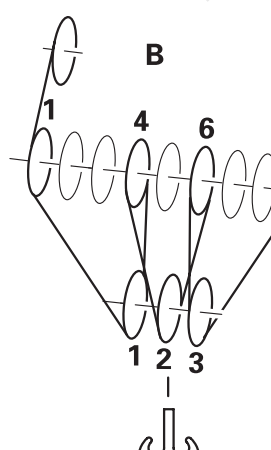
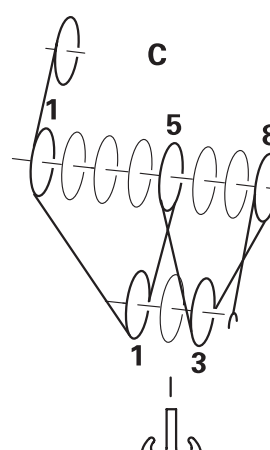
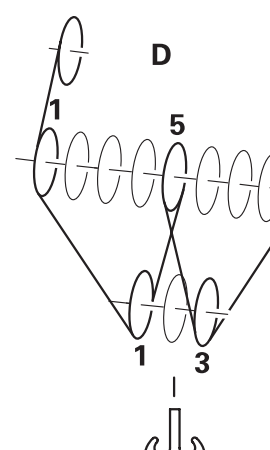

3 sheave hook block
 Max. lifting capacity of the hook block 40 t (88,185 lbs)
Max. lifting capacity with the GMK 4100:

A With 7-fall reeving	39.2 t (86,400 lbs)
B With 6-fall reeving	33.7 t (74,300 lbs)
C With 5-fall reeving	28.1 t (62,000 lbs)
D With 4-fall reeving	22.5 t (49,600 lbs)

W3167



1 sheave hook block
Max. lifting capacity of the hook block 20 t (44,090 lbs)

Max. lifting capacity with the GMK 4100:

- A** With 3-fall reeving 17.0 t (37,500 lbs)
- B** With 2-fall reeving 11.3 t (24,900 lbs)
- C** With 1-fall reeving 5.7 t (12,600 lbs)

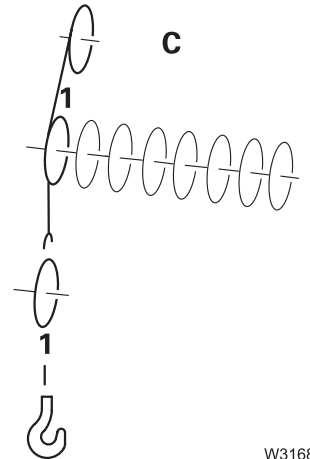
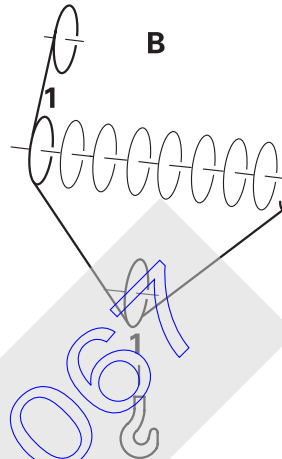
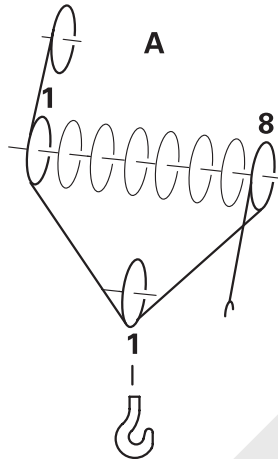

W3168



Hook tackle
Max. lifting capacity of the hook tackle 8 t (17,600 lbs)

Max. lifting capacity with the GMK 4100:

- A** 1-fall reeving 5.7 t (12,600 lbs)

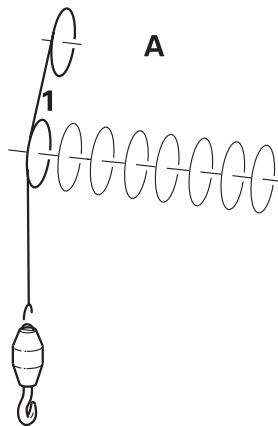

W3169

13.8.5

Installing / removing the lifting limit switch

Function of the lifting limit switch;  p. 12 - 51.

For every reeved hoist rope, you must install a lifting limit switch, attach a lifting limit switch weight and place it around the hoist rope.

Installing the lifting limit switch

You can attach the lifting limit switch on the right or left side of main boom head. Install the switch on the side that is closer to the last rope leading upwards. There can also be one lifting limit switch installed on each side.

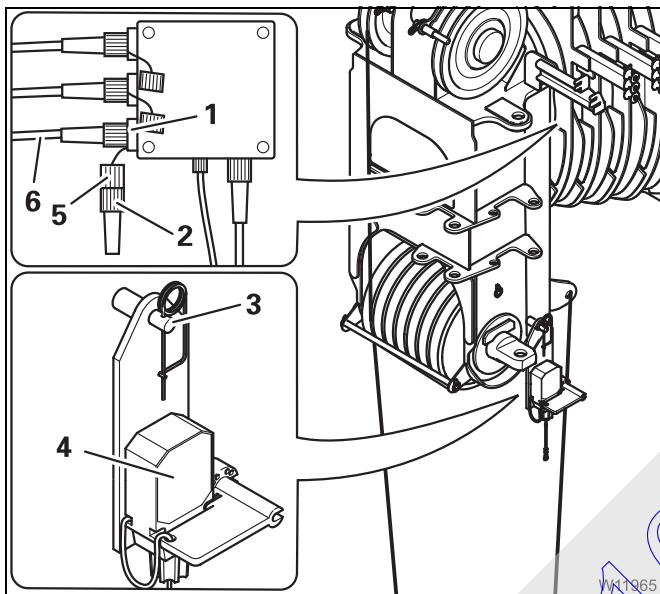

On the left side

- Fit the lifting limit switch (4) onto the holder (3) and secure it with the retaining pin.
- Remove the bridging plug (2) from the socket (1) and plug it into the dummy socket (5).
- Lay the cable (6) in such a way that it will not be damaged during crane operation, and insert the lifting limit switch into the socket (1).

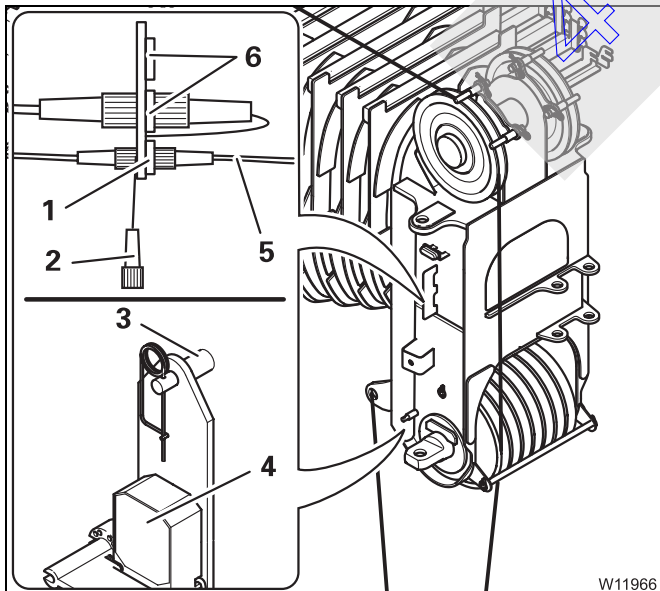

On the right side

- Fit the lifting limit switch (4) onto the holder (3) and secure it with the retaining pin.
- Remove the bridging plug (2) from the socket (1).
- Lay the cable (5) in such a way that it will not be damaged during crane operation, and insert the lifting limit switch into the socket (1).

Connections (6),  *Operating Instructions Lattice Extension.*

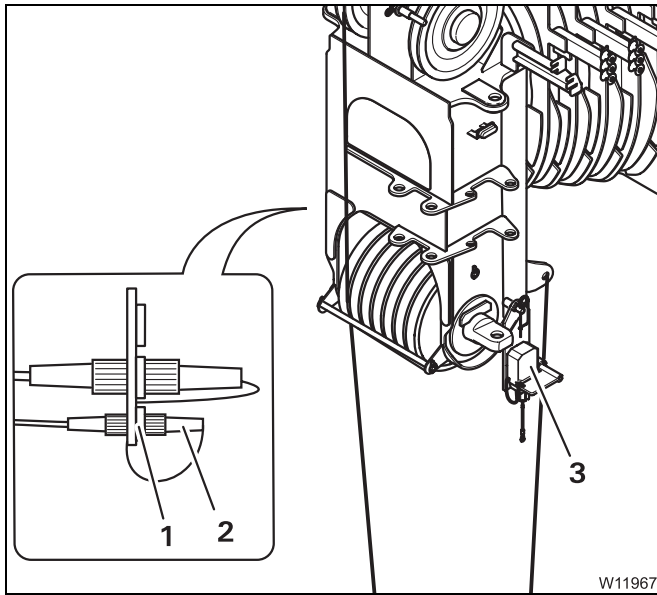

If only one lifting limit switch has been installed

- Check whether the bridging plug is in the socket that is not being used.

If, for example, the lifting limit switch (3) is installed on the left, the bridging plug (2) must be in the socket (1) on the right.

Otherwise the movements *Raise hosting gear*, *Telescope out* and *Lower the boom* will be locked.

- Check whether the lock on the lifting limit switch (3) is released;  *Unlocking*, p. 13 - 107.



Risk of damage if the lifting limit switch is locked

The lifting limit switch must not be locked. Remove the lock, if necessary. If the lifting limit switch is locked, the hook block could hit the bottom of the main boom head during the lifting procedure, resulting in damage to the hook block, main boom head and hoist rope.

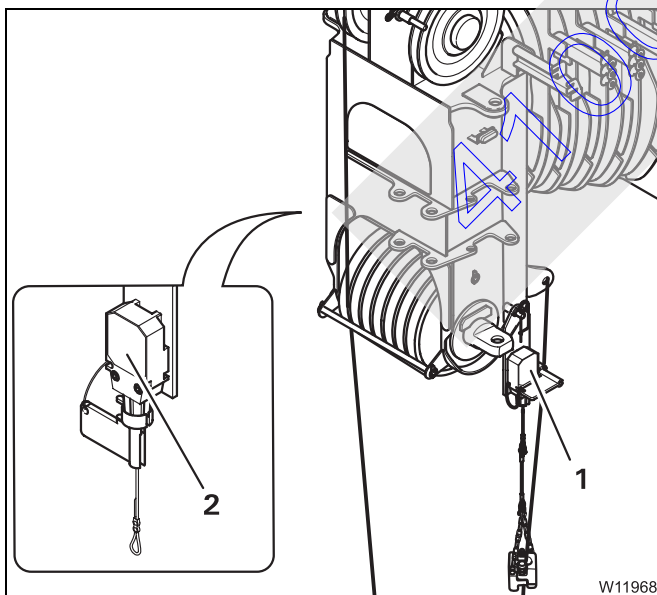

If two lifting limit switches have been installed

- Lock the lifting limit switch to which no lifting limit switch weight has been attached.

If the lifting limit switch weight has, for example, been attached to the left lifting limit switch (1), you must lock the right lifting limit switch (2);  *Locking*, p. 13 - 106.

Otherwise the movements *Raise hosting gear*, *Telescope out* and *Lower the boom* will be locked.



If two hoist ropes are reeved, you must also use two lifting limit switch weights. In this case, both lifting limit switches must be unlocked;  *Unlocking*, p. 13 - 107.



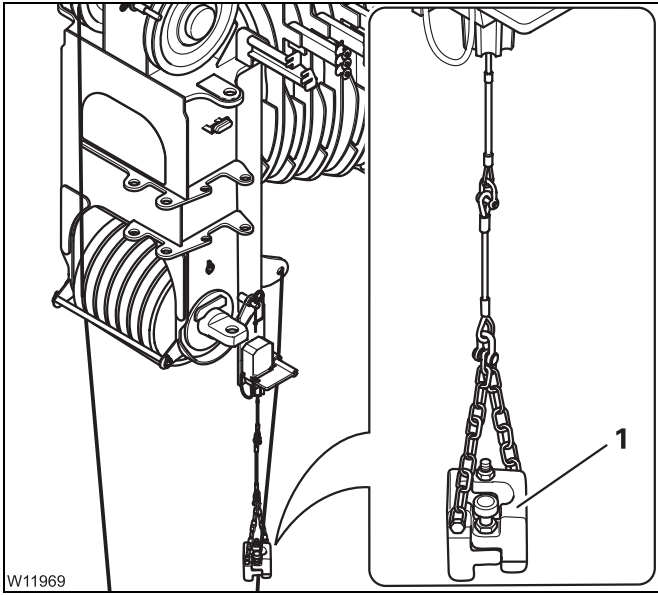

Attaching the lifting limit switch weight

- Attach the lifting limit switch weight (1).

If two hoist ropes are reeved, you must attach a lifting limit switch weight to each of the two lifting limit switches.

This lifting limit switch must not be locked;
☛ *Unlocking*, p. 13 - 107.

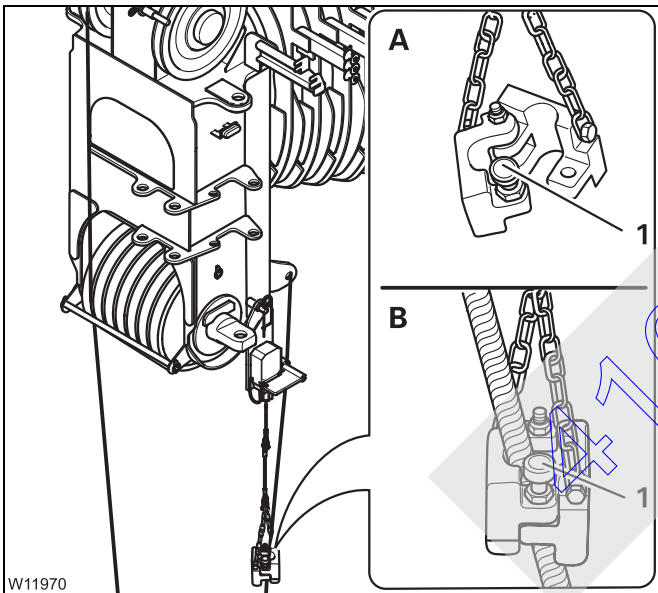

Placing a lifting limit switch weight around the hoist rope

- (A) – Pull the safety pin (1) out and fold the two halves of the weight apart.
- (B) – Place the two halves of the weight around the last rope line leading upwards.
- Pull the safety pin (1) out and fold the two halves of the weight back together.
- Make sure the safety pin locks into place and the two halves of the weight are securely attached to each other.

If two hoist ropes are reeved, you must also place a lifting limit switch weight around the second hoist rope.



If you place the lifting limit switch weight around the last rope line leading upwards, less rope will run through the lifting limit switch weight, especially if there is a high number of reevings per lifting operation. This rope line will even be at a standstill if the number of rope lines is even.

This allows you to reduce the wear of the hoist rope and lifting limit switch weight and prevent unintentional deactivation procedures that may be caused by the running hoist rope lifting the lifting limit switch weight.

Removing the lifting limit switch

This section describes complete removal.

If the hook block is to be attached to the bumper at a later point, you will need to detach the lifting limit switch weight from the hoist rope, so that you can unreeve or reeve when rigging the hoist rope. You can place the lifting limit switch weight around the hoist rope again before driving.

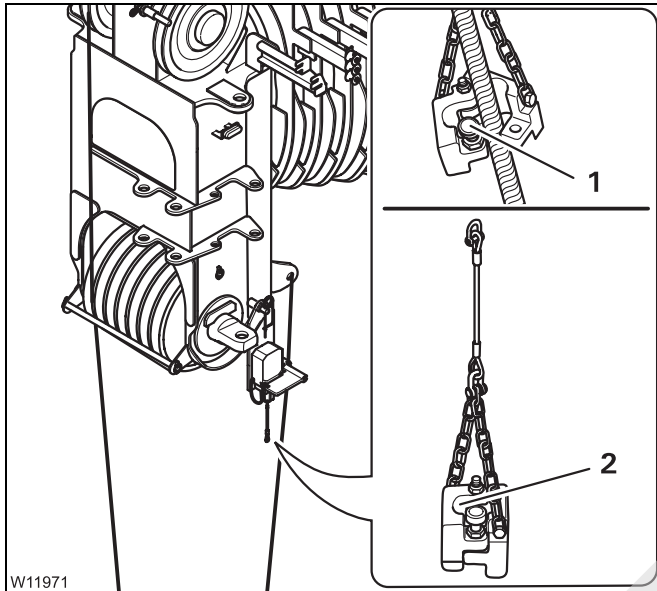

Removing the lifting limit switch weight

- Pull the safety pin (1) out and fold the two halves of the weight apart.
- Remove the halves of the weight from the rope.
- Pull the safety pin (1) out, fold the two halves of the weight back together and let the safety pin engage.
- Remove the lifting limit switch weight (2).
- Remove the lifting limit switch weight on the other side too, if necessary.

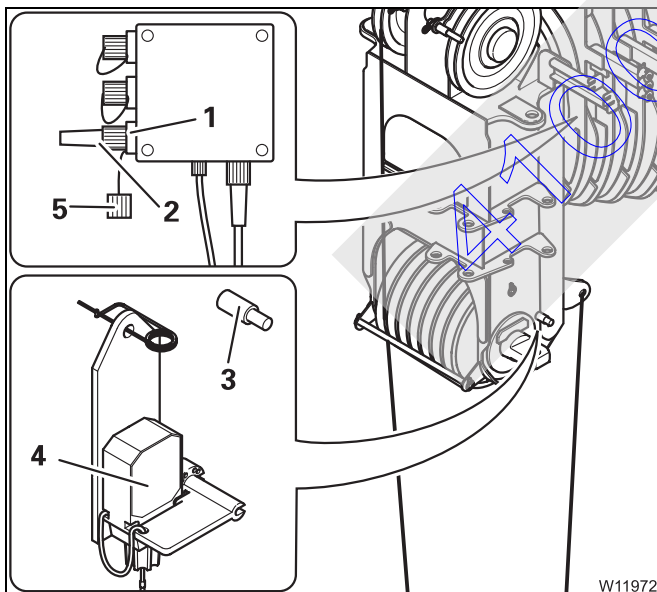

Removing the left lifting limit switch

- Pull the plug from the socket (1).
- Remove the plug (2) from the dummy socket (5) and plug it into the socket (1).
- Remove the lifting limit switch (4) from the clamp (3).
- Attach the retaining pin to the lifting limit switch.



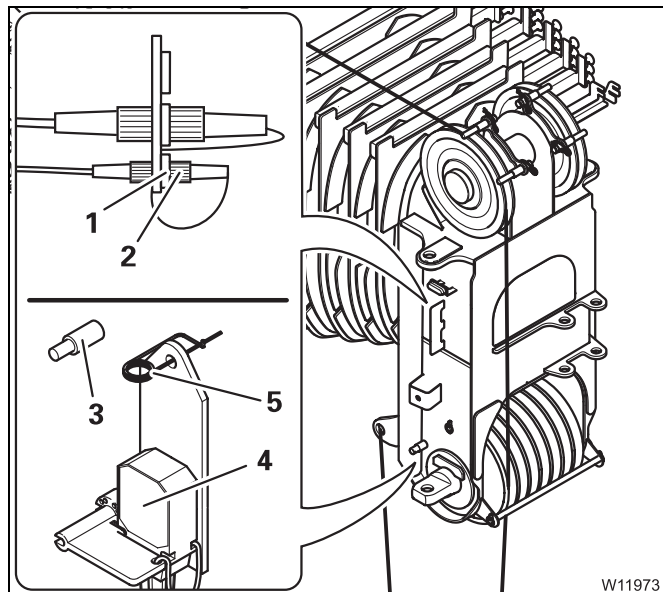

Removing the right lifting limit switch

- Pull the plug from the socket (1).
- Insert the bridging plug (2) into the socket (1).
- Remove the lifting limit switch (4) from the clamp (3).
- Attach the retaining pin (5) to the lifting limit switch.

13.8.6

Locking / Unlocking the lifting limit switch

Locking

If a hoist rope has been reeved and two lifting limit switches are installed, you must lock the lifting limit switch not used in order to enable all crane operations.



Risk of damage if the lifting limit switch is locked

The lifting limit switch to which the lifting limit switch weight is attached may under no circumstances be locked when operating the crane. If the lifting limit switch is blocked, release the locking system. This prevents the hook block from hitting the main boom head, causing damage to the hook block, main boom head and hoist rope.

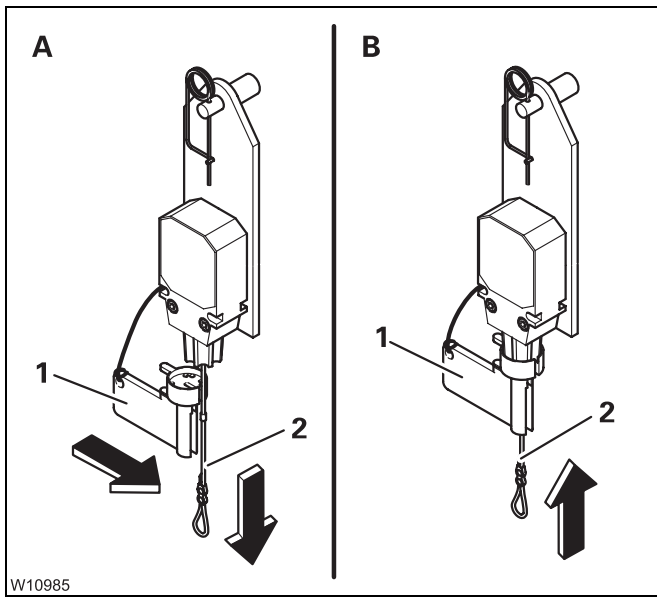

- Remove the lifting limit switch weight.
- (A) – Remove the cap (1).
- Pull down the rope (2).
- (B) – Secure the rope (2) in this position using the cap (1) – the lifting limit switch is locked and can no longer be triggered.

Unlocking

You must always remove the lock before you place a lifting limit switch weight around the hoist rope.

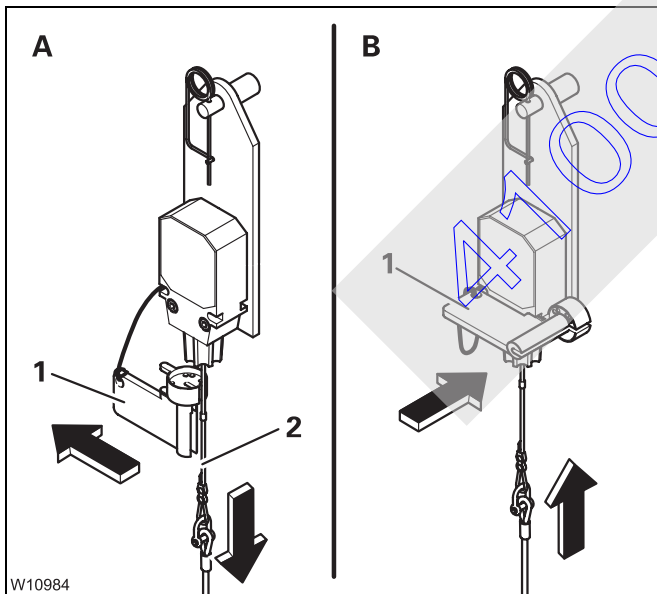

- (A) – Pull the rope (2) down and take off the cap (1) – the lock is removed.
- (B) – Fit the cap (1) onto the lifting limit switch.

13.8.7

Anemometer and air traffic control light



Risk of damage when driving on roads!

Always remove the anemometer and air traffic control light before on-road driving.

This prevents the specified overall height from being exceeded at on-road level, and the anemometer from being damaged by air currents.

Mounting

The anemometer and the air traffic control light – if provided – are located on the same rod.

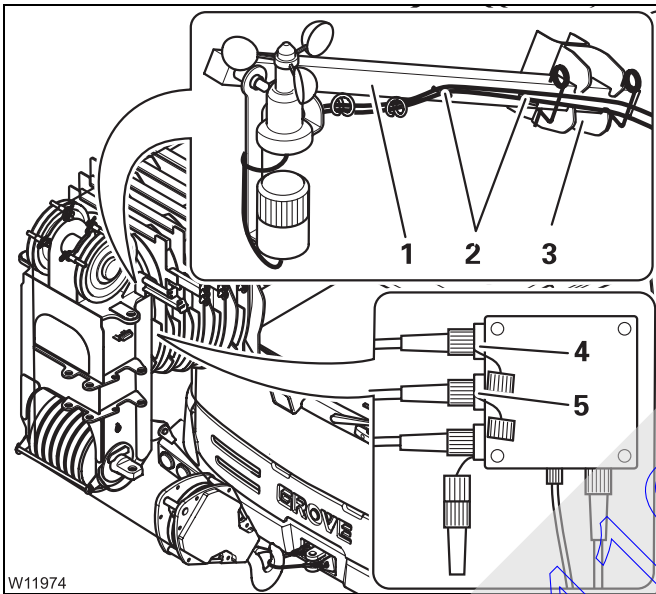

- Insert the rod (1) into the holder (3) and secure it with the retaining pins.
- Remove the cables from the holders (2) and plug
 - the anemometer into socket (4),
 - the air traffic control light into socket (5).
- Lay the cables so that they will not be damaged during crane operation.
- Check that the anemometer is able to swing so that it hangs vertically even when the main boom is raised.

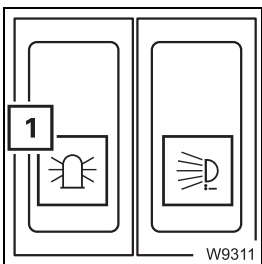

Switching the air traffic control light on and off:

To switch on: Press the switch (1) in at the bottom.

To switch off: Press switch (1) in at the top.

Removing

You must remove the rod with the anemometer / air traffic control light before driving on the road.  p. 13 - 113

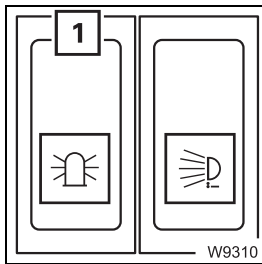

- Switch off the air traffic control light – press the switch (1) upwards and inwards.

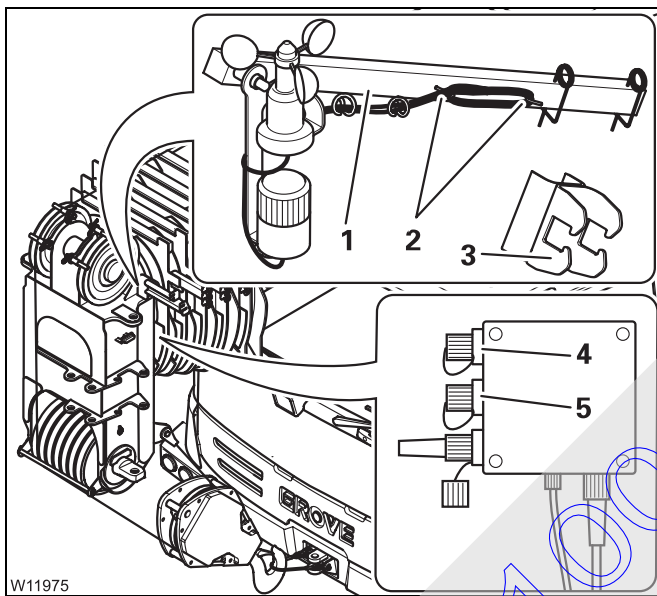

- Remove the plug and close the sockets (4) and (5) with the protective caps.
- Wind the cables onto the holders (2).
- Take the rod (1) out of the holder (3).
- For transportation, attach the retaining pins to the rod (1).

Blank page

41005067

13.9 Other rigging work

13.9.1 Rigging in free on wheels working position

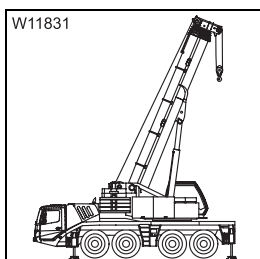

- The truck crane is supported on outriggers
- The counterweight combination required for using the truck crane free on wheels is rigged.
- Slew the superstructure into the *working position 0° to the rear*.

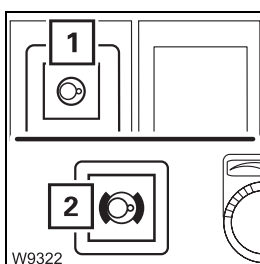

- Switch off the slewing gear so that the slewing gear brake is engaged.
 - The lamp in the button (1) must light up dimly.
 - The lamp (2) must light up.

➡ Switching off the slewing gear, p. 12 - 92.



Danger of overturning if the supporting cylinders are retracted unevenly!
Retract all of the supporting cylinders as evenly as possible. In this way you can prevent the truck crane from overturning when retracting individual supporting cylinders.

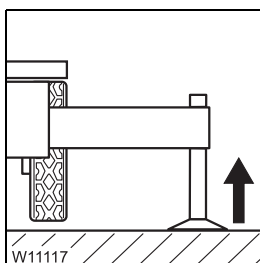

- Retract the supporting cylinders until all wheels are just above the ground.



Danger of overturning when switching on the suspension
You may under no circumstances switch on the suspension as long as the rigged truck crane is on wheels. The suspension struts would be suddenly pressed together and damaged and the truck crane could overturn when switching on the suspension.

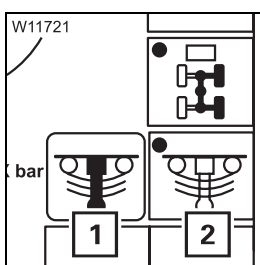

Switching on the suspension

- In the driver's cab, open the *Level adjustment system* submenu – button .
- Press the button (2) once – dot **green**.
The symbol 1 is **green** if the suspension is switched on.



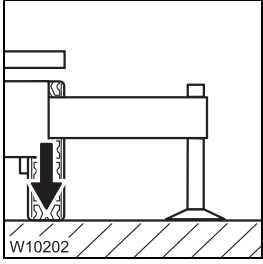

All wheels are now lowered to the ground.

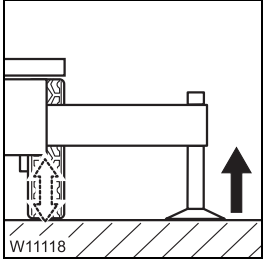

Levelling the truck crane

Move the supporting cylinders evenly while levelling. Lower the truck crane only to the extent that the suspension struts still have enough play.

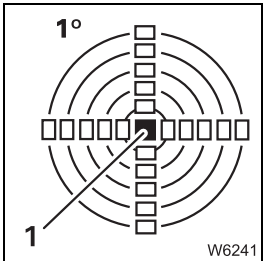

- Level the truck crane on outriggers until the lamp (1) is the only one lighting up in the measuring range 1°.

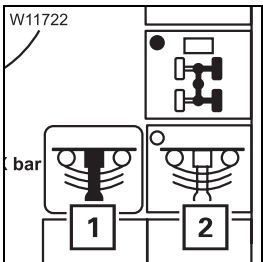

To switch off the suspension

- Press the button (2) once – dot black.
The symbol (1) is red if the suspension is switched off.

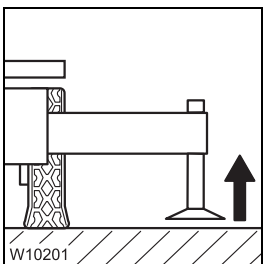

To secure the truck crane

- Retract the supporting cylinders until the outrigger pads are about 5 to 10 cm (2 to 4 in) above the ground. Leave the outrigger beams extended.



Danger of overturning if outriggers are retracted

Always leave the outriggers extended and the outrigger pads just above the ground to secure the truck crane against overturning.

Setting the SLI

- Enter the current rigging mode on the SLI; p. 12 - 21.

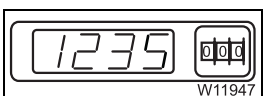

13.9.2

Railings on the turntable

Always fold out the railings when you are working above on the turntable.
Always fold in the railings before driving.



Risk of accidents when exceeding the permissible dimensions

Fold in the railings before driving. When the railings are unfolded, the overall height specified for on-road driving is exceeded.

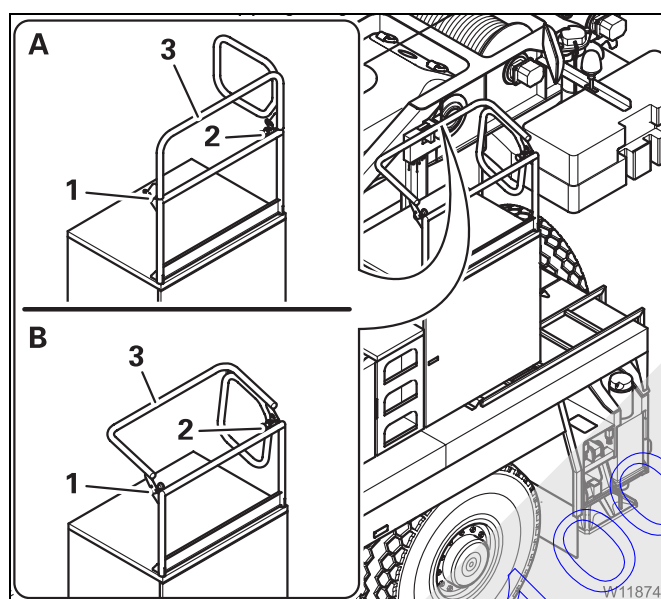

(A) – Unfolding

- Release the bolt (1).
- Fold the railings (3) up until the bolts (1) and (2) latch into place.

(B) – Folding in

- Loosen the bolts (2) and (1).
- Fold the railings (3) down until the bolt (1) latches into place.

13.9.3

Mirror for crane operation

For crane operation you must adjust the mirrors. All mirrors must be folded in / removed for driving.



Risk of accidents when exceeding the permissible dimensions

Fold the necessary mirrors in for driving. With the mirrors folded out, the specified overall height at on-road level and the specified overall width for driving on roads is exceeded.

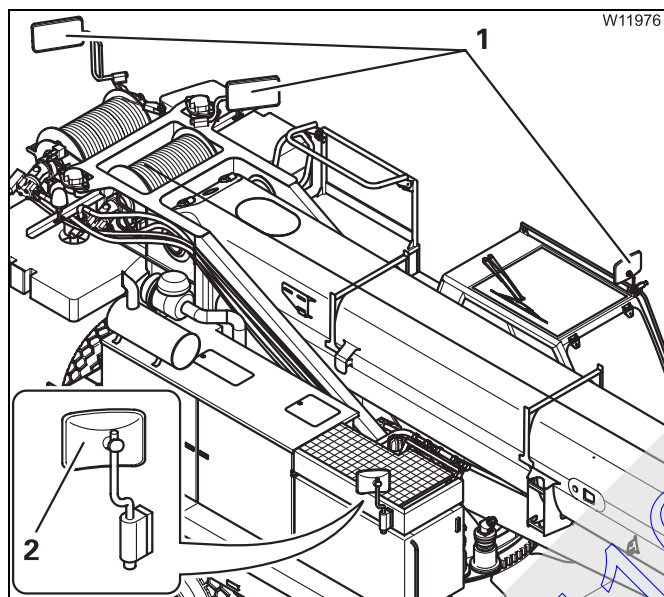

For crane operation

- Fold out the railings on the turntable;  p. 13 - 113.
- Adjust the mirrors (1) in such a way that you have a clear view of the rope running on the hoisting gears.
- Insert the mirror (2) into the holder.
- Adjust the mirror (2) in such a way that you can see the outriggers from the crane cab.

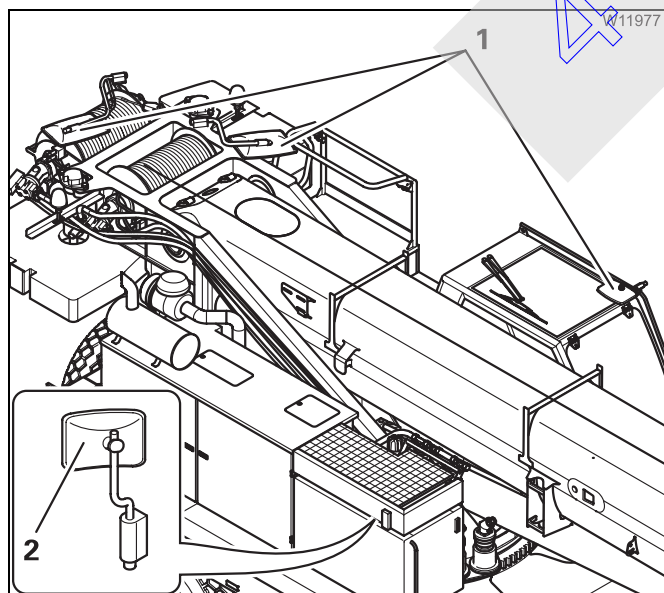

For driving

- Fold the mirrors (1) downwards.
- Remove the mirror (2) to avoid dazzling other drivers on the road.
- Stow away the mirror (2).

14 Driving the rigged truck crane

14.1	Route	14 - 2
14.2	permissible rigging modes and axle loads	14 - 2
14.2.1	To drive without a load	14 - 2
14.2.2	To drive with a load	14 - 3
14.2.3	Axle loads	14 - 3
14.3	Before driving the rigged truck crane	14 - 4
14.3.1	Checking the tyre pressure and the wind speed	14 - 4
14.4	Driving from the driver's cab	14 - 5
14.4.1	Preparing to drive	14 - 5
14.4.2	While driving	14 - 6
14.5	Driving from the crane cab	14 - 7
14.5.1	Preparing to drive	14 - 8
14.5.2	Opening / closing the Driving mode submenu	14 - 8
14.5.3	Starting / turning off the engine for driving	14 - 11
14.5.4	Steering	14 - 12
14.5.5	Operating the transmission	14 - 15
14.5.6	Starting	14 - 17
14.5.7	While driving	14 - 17
14.5.8	Warning messages	14 - 18
14.5.9	Possible connections	14 - 19
14.5.10	After driving	14 - 21

41005067

41005067

14

Driving the rigged truck crane

This section describes driving the truck crane with the counterweight rigged. If a lattice extension is rigged as well;  *Operating Instructions Lattice Extension*.



Risk of accidents if your view of the truck crane is partially obstructed

When driving the truck crane, always stay in visual or radio contact with a banksman who can observe the parts you are unable to see (e.g. the raised boom in 0° to the rear position).



Risk of overturning due to superstructure slewing

When driving the rigged crane, the slewing gear must be switched off – slewing gear brake engaged.



Risk of accidents when driving with a lifted load

The truck crane may only be driven with a lifted load if it is in a *Free-on-wheels* working position in accordance with the *Lifting capacity table*. The truck crane must not be driven from the driver's cab with a raised load.



Risk of accidents when driving on public roads

Driving on public roads is only permissible if all requirements listed in the CHECKLIST: inspections before on-road driving are met;  p. 5 - 1. Driving from the crane cab and driving with the truck crane rigged is not permissible on public roads.

14.1

Route

The route must be even. Uneven surfaces cannot be compensated with the level adjustment system.

The ground of the route must be stable enough to bear the axle loads.

If the surface pressure of the tyres exceeds the permissible load on the ground, the surface area of the tyres must be increased with packing of stable material (e.g. wooden planks).

14.2

permissible rigging modes and axle loads

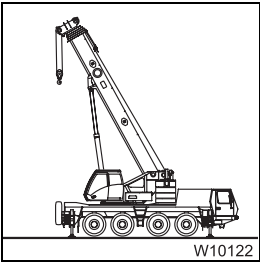

- Bring the truck crane into a *Lifting capacity table* Free-on-wheels working position;  *Rigging in free on wheels working position*, p. 13 - 111.
 - The SLI code according to *Lifting capacity table* for the Free-on-wheels working position is entered with the rigged counterweight.
 - The slewing gear is switched off.
 - The truck crane is standing on all wheels.
- For reasons of safety, extend the outrigger beams in accordance with the available space. The outrigger pads may not touch the ground while driving the crane.
- You can drive without a load and, under certain circumstances, even with a lifted load. Observe the information in the corresponding section.

14.2.1

To drive without a load

- Bring the main boom to an inclination permitted within the working range.
- Tie down the hook block so that it cannot swing back and forth.

14.2.2

To drive with a load

The truck crane may only be driven from the crane cabin when loads are being lifted.



Risk of accidents when driving with a lifted load

When driving with a lifted load, you must be able to operate the crane at any time in the event of an emergency. That is why the truck crane may not be driven from the driver's cab with a lifted load.

- Lift the load.
- Bring the main boom to an inclination permitted within the working range.



Risk of accidents when driving with a lifted load

Secure the load against swinging when driving the rigged truck crane. In this way you can prevent the swinging load from leaving the permissible working range and the truck crane overturning.

- Tie down the load so that it cannot swing back and forth.

14.2.3

Axle loads

The axle loads do not exceed 25.0 t (55,100 lbs), if the main boom is within the permissible working range in a permissible *Lifting capacity table Free-on-wheels* working position.

14.3

Before driving the rigged truck crane

14.3.1

Checking the tyre pressure and the wind speed

- Check that the tyres are all at the prescribed pressure levels;  *Tyres*, p. 8 - 5.



Risk of damage to the tyres

Only drive the rigged truck crane if the tyres are at the prescribed pressure level.

Never reduce the tyre pressure in order to increase the bearing surface of the tyres.

The wind speeds apply for driving the truck crane as stated in *Lifting capacity table* for the entered SLI code.

- Check the wind speed;  p. 12 - 42.



Risk of accidents due to excessively high wind speeds

You may not drive the rigged truck crane if the wind speed exceeds the maximum permissible values specified in the *Lifting capacity table*. In this case you must bring the truck crane into a safe condition.

41005067

14.4

Driving from the driver's cab

If the truck crane is equipped with the Driving mode submenu, you can also drive the truck crane from the crane cab;  p. 14 - 5.



Risk of accidents when driving the truck crane from the driver's cab with a lifted load!

With a lifted load, only drive the truck crane from the crane cab. You must be able to carry out crane movements in an emergency at all times.

14.4.1

Preparing to drive

Transmission

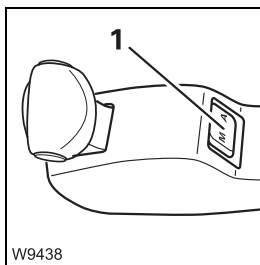

W9438

- Press the switch (1) where is says **M** – *Manual*.
- Shift to the lowest starting gear;  p. 5 - 32.
This prevents the transmission from upshifting and keeps the speed at a minimum.

Switching on separate steering

When driving the rigged truck crane, the separate steering must be switched on.



Risk of damage to the steering linkage

Always switch on separate steering before driving the rigged truck crane and steer the truck crane only when it is rolling.

The steering linkage can be damaged if separate steering is switched off or if you steer the vehicle while it is stationary.

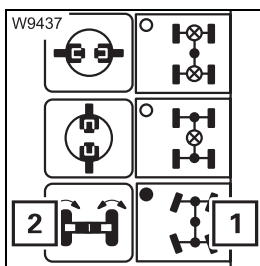

W9437

- Press the button (1) once – dot **green**.
The symbol (2) is displayed in **red** if the separate steering is switched on.

Connections

If necessary, you can connect the longitudinal and transverse differential locks;  p. 5 - 63.

14.4.2

While driving

- Only drive slowly, do not upshift.
- The turning radius should be as large as possible when driving around corners!
- Steer the truck crane only when it is rolling and avoid sudden steering movements.



Risk of damage to the steering linkage

The steering linkage can be damaged if the steering is operated while the vehicle is stationary.



Danger of overturning when switching on the suspension

The suspension must be deactivated (locked) as long as the rigged truck crane is on wheels.

When switching on the suspension, the suspension cylinders would suddenly be pressed together and damaged, and the truck crane could overturn.

Never align the truck crane with the level adjustment system if the ground is uneven. In this case you must raise the truck crane with the outrigger cylinders, level it and then re-lower it. ► *Levelling the free-standing truck crane*, p. 13 - 51.

410050061

14.5

Driving from the crane cab



Risk of accidents when driving with a lifted load

The truck crane may only be driven with a lifted load when it is in the *Free on wheels* working position and if the current rigging mode has been entered on the SLI.



Risk of accidents due to swinging hook block / load

Secure the hook block / load for driving so that it cannot swing. Start to drive slowly so that the hook block / load does not swing.



Risk of accidents if your view of the truck crane is partially obstructed

When driving the truck crane, always stay in visual or radio contact with a banksman who can observe the parts you are unable to see (e.g. the raised boom in 0° to the rear position).



Risk of overturning due to superstructure slewing

When driving the rigged crane, the slewing gear must be switched off – slewing gear brake engaged. The turntable must be locked.



Risk of accidents when an increased idling speed is used

If necessary, reset the idling speed to the default value. Do not drive with increased idling speed. You may only drive the truck crane from the crane cab at the lowest speed possible.

14.5.1

Preparing to drive

Make sure that the rigging mode for driving with a load or without a load is set correctly;  p. 14 - 2.

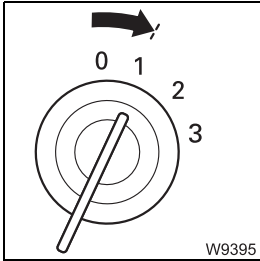

In the driver's cab

- The ignition key is in position **1** so that the steering cannot block.
- The driver's cab is locked with the second ignition key in order to secure it against unauthorised use – e.g. braking.

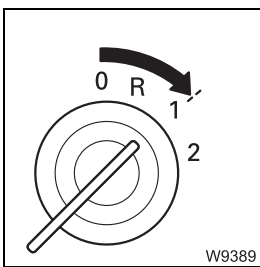

In the crane cab

- The ignition is switched on.
- The hand-held control has been disconnected and bridging plugs have been plugged into all superstructure and carrier sockets.
- The parking brake is engaged.
- The seat contact switch (or a dead man's switch) is actuated.

The engine for crane operation can be switched on or off.

14.5.2

Opening / closing the Driving mode submenu

You can open the *Driving mode* submenu manually or automatically.

Automatically



Risk of accidents due to truck crane starting to move

Always apply the parking brake before you open the submenu automatically. This prevents the truck crane from starting to move unintentionally.

The superstructure ignition must be switched on for approx. 30 seconds.

- Press the button **(1)** **down** once.
 - The carrier ignition is turned on.
 - The lamp in button **(1)** flashes.
 - The transmission shifts to neutral position.
 - The *Driving mode* submenu opens automatically.

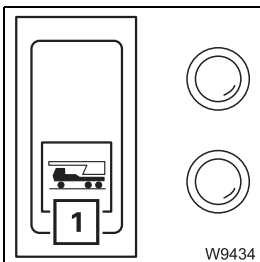

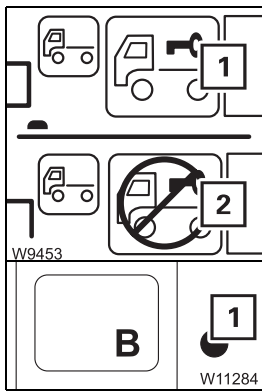

If the symbol (1) is **red**, bring the ignition key in the driver's cab to position 1 – the symbol turns **green**.

If the symbol (2) is displayed, apply the parking brake.

When the lamp (1) lights up; *Warning messages*, p. 14 - 18.

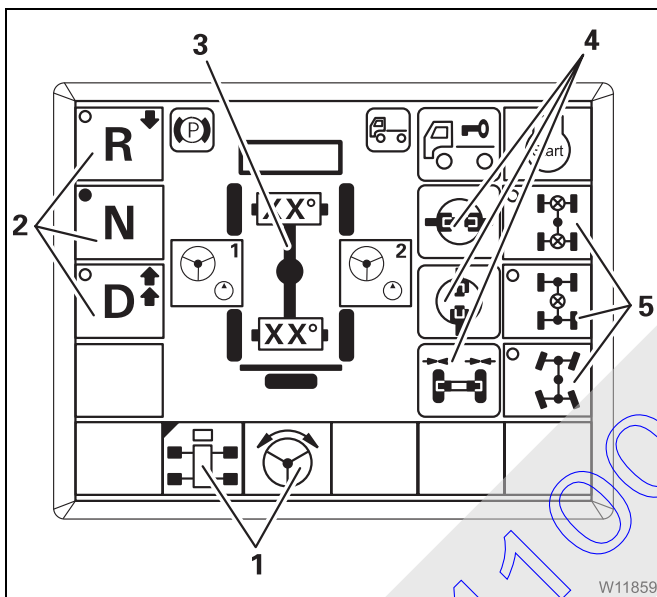

The transmission is in neutral position – dot in the symbol **green**.

The dots in the symbols (5) indicate the status saved last; the corresponding gear shifts are performed.

The displays (4) and (3) indicate the current gear switching state.

The buttons (1) and (5) are active.

The buttons (2) are not active.

The submenu can only be closed manually.

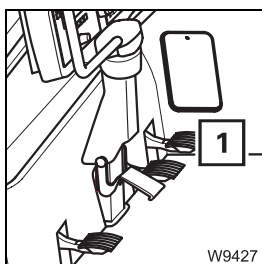

When the carrier ignition is switched on, the accelerator (1) takes effect on the engine for driving. Starting the engine; p. 14 - 11.

If you switch on the carrier ignition while your foot is on the accelerator, the accelerator takes effect on the engine for crane operation until you take your foot off the accelerator once.

Thereafter you can only start the engine for crane operation with the button ; p. 11 - 16.





If you now turn off the carrier ignition, the same state is established as after manual opening; *Manually*, p. 14 - 10.

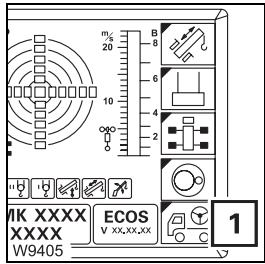

Manually

You can open the *Driving mode* submenu manually at any time.



- If necessary, open the main menu  and press the button (1) once.

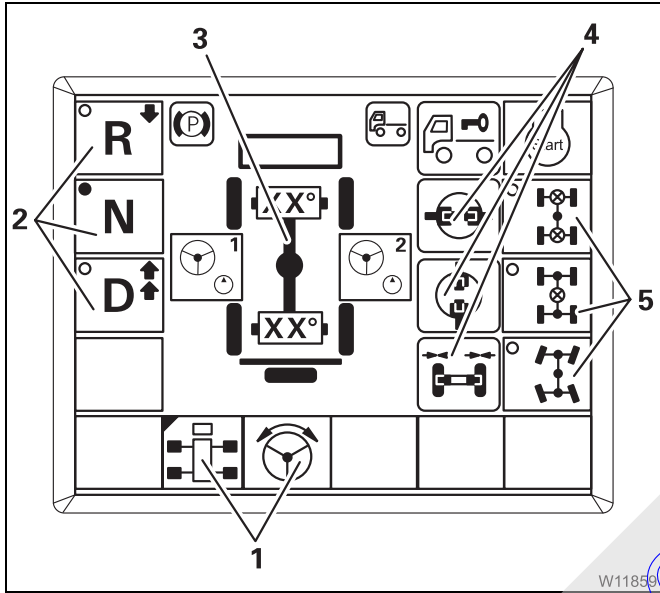

The *Driving mode* submenu opens.

The buttons (1) (2) and (5) are not active.

The dots in the symbols (2), (5) and the displays (3), (4) indicate the current switching state.

If you now turn on the carrier ignition, the same state is established as after automatic opening.  p. 14 - 8.

Closing

You can only close the *Driving mode* submenu manually.

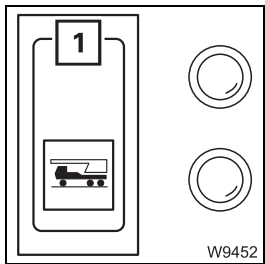

- Press the button (1) up once.
 - The engine for driving is turned off.
 - The carrier ignition is turned off.
 - The lamp in the button (1) goes out.
 - The transmission shifts to neutral position.

The same state is established as after opening the submenu manually.



The lamp (1) lights up.

- Press button (2) once.

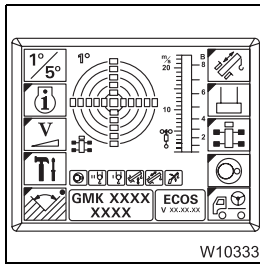

The main menu opens.

The accelerator now takes effect on the engine for crane operation.



The lamp next to the button **Esc** also lights up if you turn the ignition key in the driver's cab away from position 1.

14.5.3

Starting / turning off the engine for driving

To start the engine

All activities and inspections required to start the engine must be carried out before starting the engine; **|||** p. 4 - 1.

- All the requirements listed in the section on preparing to drive have been fulfilled; **|||** p. 14 - 8.
- The *Driving mode* submenu opened automatically; **|||** p. 14 - 8.

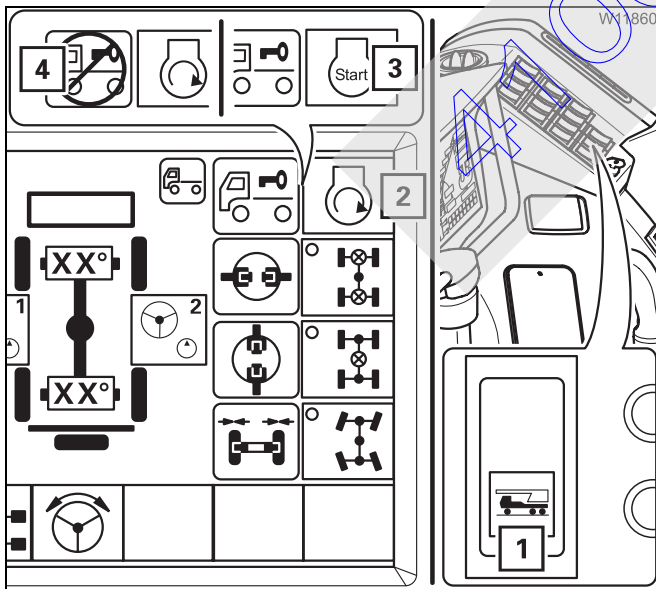

- Press button **(3)** once. The engine starts.

When the engine is running

- The symbol **(2)** is displayed.
- The lamp in the button **(1)** lights up.

When the symbol **(4)** is displayed, you might be actuating the accelerator and the brake pedal at the same time - otherwise;

||| *Warning messages*, p. 14 - 18.



Turning off the engine

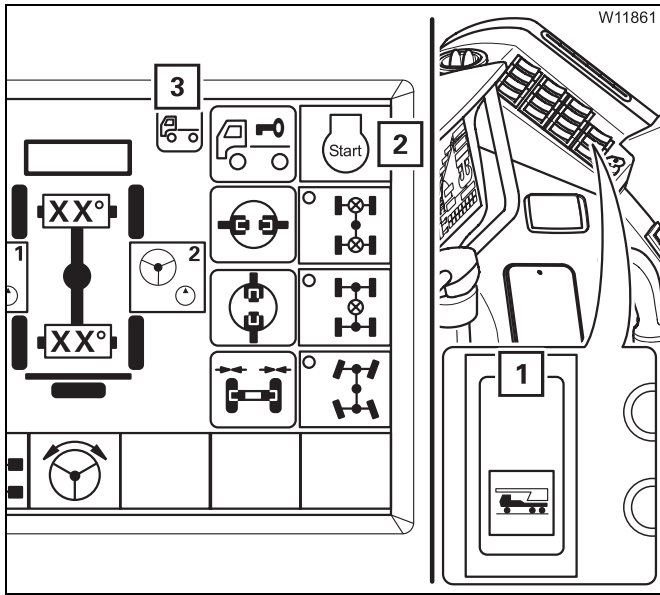

- Press the button (1) **up** once.
 The carrier ignition is turned off and the engine is switched off.
 - The lamp in the button (1) goes out.
 - The symbol (2) is displayed.
 - The symbol (3) turns red.

14.5.4

Steering

Switching on

- Have the *Driving mode* submenu open automatically; p. 14 - 8.

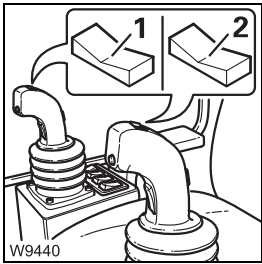

- The steering is switched on when the submenu opens.
- The button (1) is assigned the *Steering* function.
 - The button (2) can be switched to the *Separate steering* function.

Adapt steering direction

You can adjust the function of the buttons in the control levers to the super-structure position.

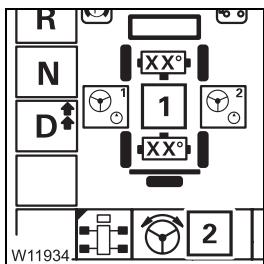

- To switch over the steering direction, press the button (2).

The display (1) shows the current setting:

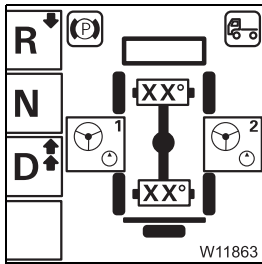

- Turned forwards

The buttons' direction of movement corresponds to the steering direction of the truck crane if the superstructure is in the 180° to the front position.

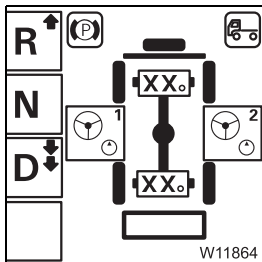

- Turned backwards

The buttons' direction of movement corresponds to the steering direction of the truck crane if the superstructure is in the 0° to the rear position.



The currently set steering direction is retained after turning the ignition off and on again.

Displays when steering

The current steering angle of the wheels is displayed.

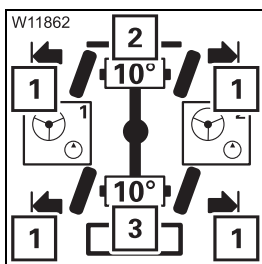

The symbols (1) show that the corresponding wheels are steered to the end position.

The displays (2) and (3) show the current steering angle in degrees, e.g. 10° . With normal steering, the display (2) does not change.

Normal steering

When driving a rigged crane, use the separate steering.

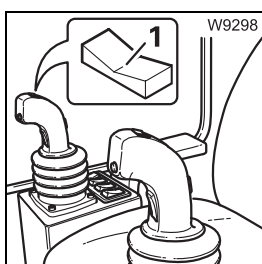

With normal steering, the wheels on the first and second axle lines are steered with the button (1). The following applies when the steering direction is set correctly:

- Right-hand turn:** • Push the button to the right.
- Left-hand turn:** • Push the button to the left.



Separate steering You can switch between normal steering and separate steering.

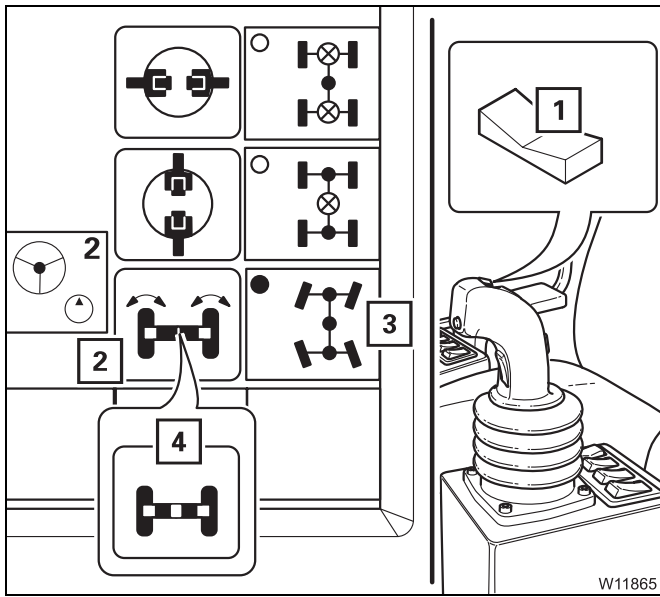

Switching to separate steering

- Press the button (3) once – dot **green**.
- If the fourth axle is unlocked – symbol (3) **yellow**:
 - Using the button (1), steer until the third and fourth axle lines have the same steering angle.
- When the connection between the third and fourth axle lines engages, the system switches to separate steering – symbol (2) **red**.



If the error symbol is displayed, please contact **CraneCARE**.

Steering with separate steering

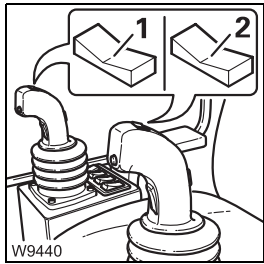

- Steer the first and second axle lines with the button (1).
- Steer the third and fourth axle lines with the button (3). The following applies when the steering direction is set correctly:
 - Left-hand turn:**
 - Push the button to the left.
 - Right-hand turn:**
 - Push the button to the right.

The axle line is steered as long as you keep the button pressed or until an end position is reached.

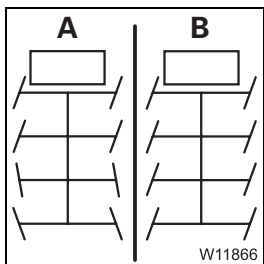

You can move the third and fourth axle lines for turning corners (A) or for crab travel (B); see p. 5 - 72.

Switching to normal steering mode

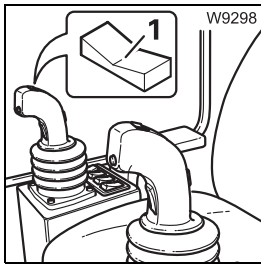

- Steer the wheels of the first and second axle lines as far as possible to the right or the left with the button (1) and keep them in this position until the system has switched to normal steering.

The switching operation is not started unless the wheels of the front axle lines are turned as far as they will go.

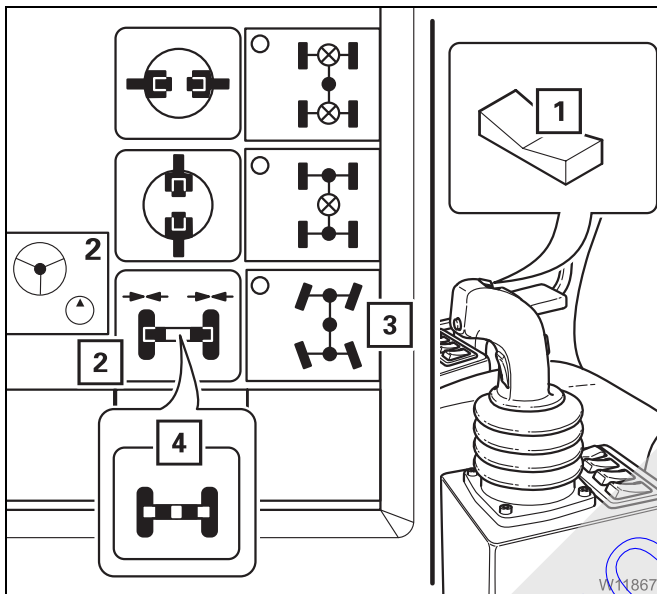

- Press the button (3) once – dot **black**.
- Use the button (1) to steer the rear axle lines in the opposite direction of the front axle lines until the symbol (4) is **yellow**.

The second and fourth axle lines are now connected.

- Use the button (1) to steer the third axle line into the straight position until the symbol (2) is **green**.

The third axle line is now locked and the system is switched to normal steering.

14.5.5

Operating the transmission

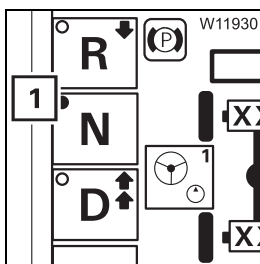

After the submenu has opened automatically, the buttons next to the symbols **R**, **N** and **D** have no function.

The transmission is in neutral position – dot (1) green.



Driving direction

The reverse (**R**) and forwards (**D**) driving directions always refer to the carrier. If the steering direction is set appropriately, the arrows in the symbols indicate the driving direction in relation to the direction of vision from the crane cab.

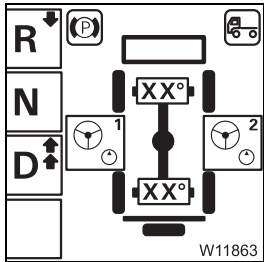

In the 180° working position to the front, select

- transmission mode **R** for driving backwards in relation to the direction of vision
- transmission mode **D** for driving forwards in relation to the direction of vision.

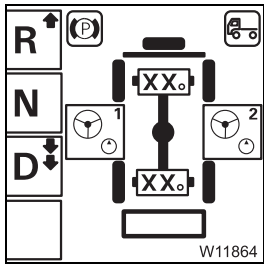

In the 0° working position to the rear, select

- transmission mode **D** for driving backwards in relation to the direction of vision.
- transmission mode **R** for driving forwards in relation to the direction of vision.

Selecting the transmission mode

The truck crane is stationary.

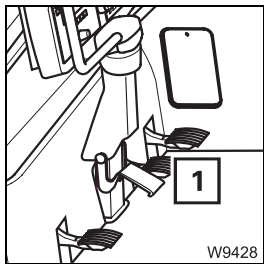

- Actuate the brake pedal (1).

The buttons next to the symbols **R**, **N** and **D** are active.

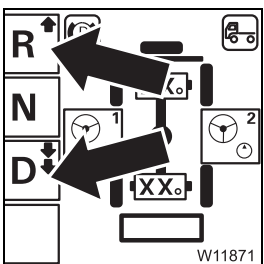

Switch to the required transmission mode **R** or **D**.

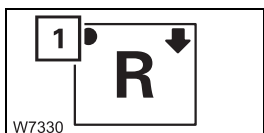

- Take your foot off the brake pedal only after the starting gear is engaged – dot (1) **green**, e.g. in transmission mode **R**.

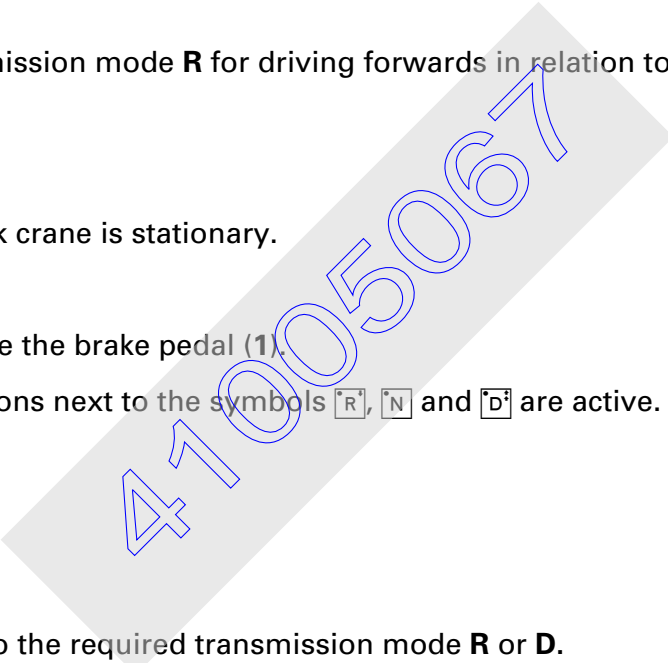

14.5.6

Starting



Risk posed by unexpected rolling

Also apply the parking brake before starting on sloping ground. The gear will only be engaged after you step on the accelerator. This can lead to the truck crane starting to move (also backwards) while you are moving your foot from the brake pedal to the accelerator.

To start moving, you have to:

- step on the accelerator while the parking brake is engaged
- release the parking brake after the gear has engaged (motor sound changes).

14.5.7

While driving

The speed is limited to a maximum of 8 km/h (5 mph).



Risk of accidents when driving with a lifted load

The maximum permissible speed for driving with a lifted load is 1.5 km/h (1 mph).

With a load lifted, drive at the lowest possible speed, at the most 1.5 km/h (1 mph). The speed is not automatically limited to this value.

- The turning radius should be as large as possible when driving around corners!
- Do not steer the truck crane when it is stationary.



Risk of damage to the steering linkage

The steering linkage can be damaged if the steering is operated while the vehicle is stationary.





Danger of overturning when switching on the suspension

The suspension must be deactivated (locked) as long as the rigged truck crane is on wheels.

The suspension would be suddenly pressed together and damaged and the truck crane could overturn when switching on the suspension.

Never align the truck crane with the level adjustment system if the ground is uneven. In this case you must raise the truck crane with the outrigger cylinders, level it and then re-lower it; *Levelling the free-standing truck crane*, p. 13 - 51.

14.5.8

Warning messages

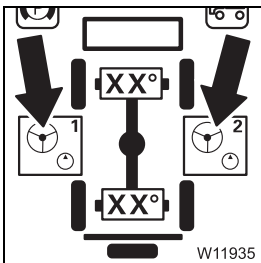

Warning for steering circuit 1 and steering circuit 2

The function is identical with the displays on the ECOS display in the driver's cab; p. 3 - 46.

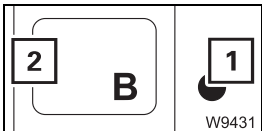

In the event of a warning message on the carrier, the lamp (1) flashes.

- Press button (2) once – the *Warning* submenu opens.

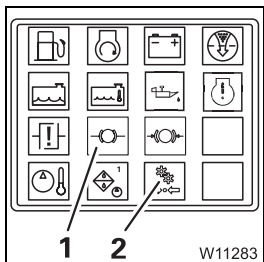

If symbol (1) or (2) is red

The supply pressure in the secondary consumers is too low.

- Let the engine for driving run until the supply pressure has been built up – symbols grey; *To start the engine*, p. 14 - 11.

You can speed up the process by stepping on the accelerator.

When other symbols are red

Warning submenu, p. 12 - 102.

14.5.9

Possible connections

You can make the following connections, one after the other:

- connect longitudinal differential locks
- connect transverse differential locks.

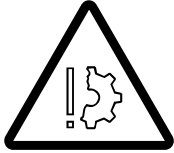

Risk of damage to the differential locks

Leave the transverse differential locks switched on only for as long as necessary. Always switch off the transverse differential locks before driving on a firm surface.

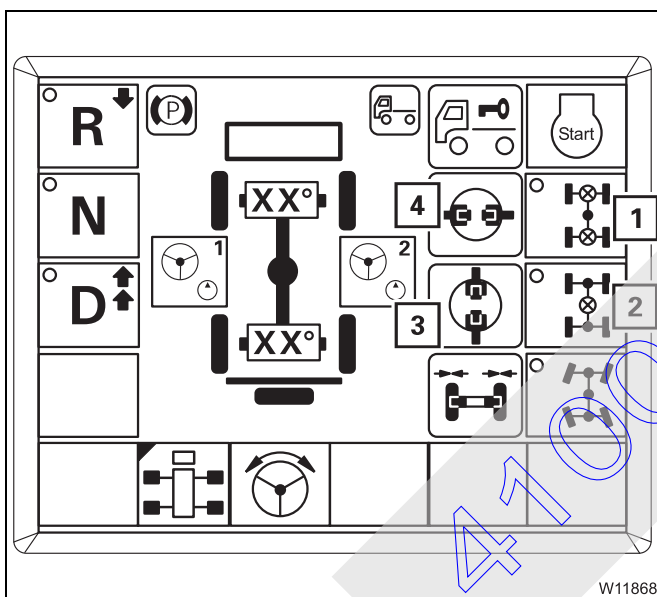

After automatic opening, the buttons (1) and (2) are active.

The displays (3) and (4) indicate the current switching state.



If the error symbol is shown during the following gear changes, contact **CraneCARE**.



Longitudinal / transverse differential locks

With an 8 x 8 x 8 drive, the drive of the second axle line is switched on and off together with the longitudinal differential locks.

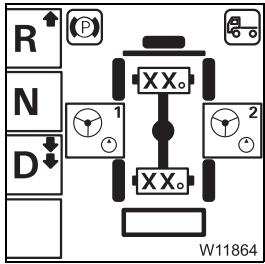

- Straighten the steering
- Stop the truck crane

For switching on and off, the current speed needs to be under about 5 km/h (3 mph).

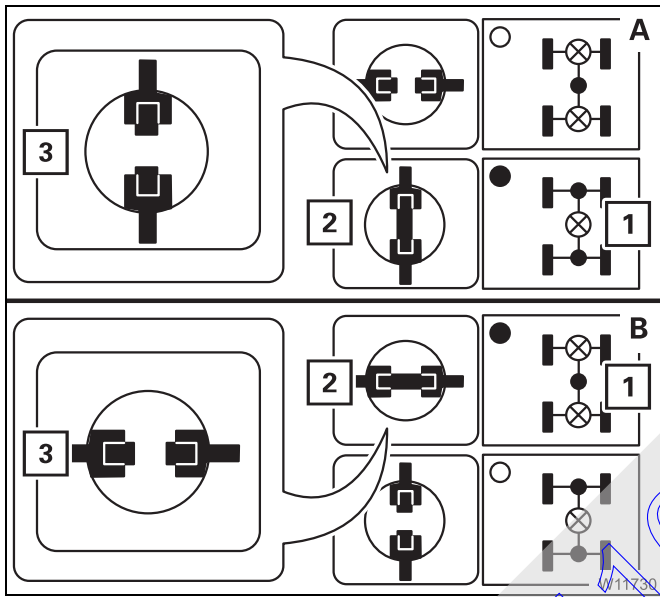

Switching on

- Press button (1) once for the
 - longitudinal differential locks (A) or
 - transverse differential locks (B), the dot turns **green**.
- Start moving slowly – Display:
 - initially symbol (3) – yellow,
 - then symbol (2) – **red**, differential locks on.

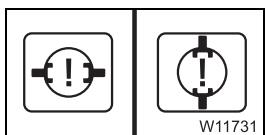

If the error symbol is displayed, please contact **CraneCARE**.

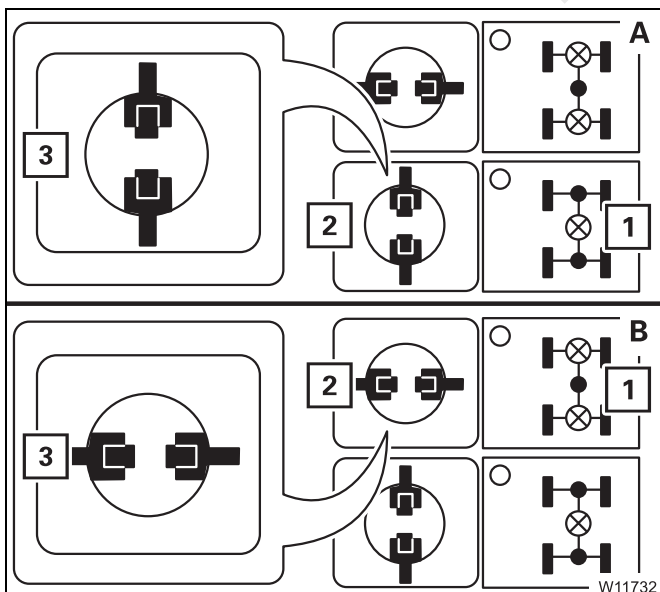

Switching off

- Press button (1) once for the
 - longitudinal differential locks (A) or
 - transverse differential locks (B), the dot turns **black**.

Display:

- initially symbol (3) – yellow,
- then symbol (2) – **green**, differential locks off.

If symbol (2) is not displayed, then drive back and forth slowly.

14.5.10 After driving

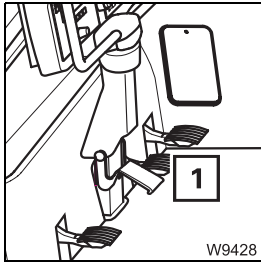

- Bring the truck crane to a halt with the brake pedal (1).
- Turn off the engine for driving, if necessary;  p. 14 - 12.

- Restore the original condition:
 - switch off the longitudinal differential locks
 - switch off the transverse differential locks
 - switch to normal steering mode.

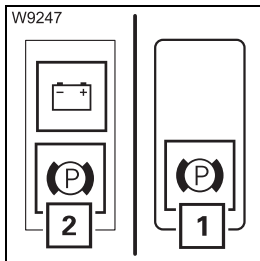

- Engage the parking brake
- Press the button (1) down once until the lamp (2) lights up.

- Remove the ignition key from the ignition lock in the driver's cab and lock the driver's cab to prevent unauthorised access.

Put the truck crane on outriggers if you do not intend to work in the *Free-on-wheels* working position.

Blank page

41005067

15 Malfunctions during crane operation

15.1	Emergency stop switch.	15 - 1
15.2	What to do when a malfunction occurs during crane operation	15 - 3
15.3	Fuses.	15 - 5
15.3.1	Fuses on the turntable	15 - 6
15.3.2	Fuses in the crane cab	15 - 8
15.3.3	Fuses in the battery box.	15 - 10
15.3.4	SLI fuses	15 - 11
15.4	Finding and eliminating malfunctions.	15 - 13
15.4.1	Malfunctions on the engine	15 - 13
15.4.2	Malfunctions on the main hoist / auxiliary hoist	15 - 15
15.4.3	Malfunctions on the derricking gear	15 - 16
15.4.4	Malfunctions in the telescoping mechanism	15 - 17
15.4.5	Malfunctions on the slewing gear	15 - 20
15.4.6	Malfunctions on the counterweight hoist unit	15 - 21
15.4.7	Malfunctions in the hydraulic system / hydraulic oil cooler	15 - 22
15.4.8	Malfunctions when inclining the crane cab	15 - 22
15.4.9	Malfunctions when operating with the hand-held control	15 - 22
15.4.10	Malfunctions when driving from the crane cab	15 - 23
15.4.11	Malfunctions on the outriggers	15 - 24
15.4.12	Troubleshooting on the SLI	15 - 25
15.4.13	Malfunctions ECOS – superstructure	15 - 32
15.5	Emergency operations and programs	15 - 35
15.5.1	Mechanical emergency operation for retracting	15 - 36
15.5.2	Telescoping emergency program	15 - 39
15.5.3	Entering the current telescoping	15 - 49
15.5.4	Emergency operation with the hand-held control	15 - 51
15.5.5	Switching on emergency operation in coolant circuit	15 - 55
15.6	Hydraulic emergency operation.	15 - 57
15.6.1	Operating principle	15 - 57
15.6.2	Connecting/disconnecting hoses	15 - 58
15.6.3	Activating/deactivating emergency operation	15 - 59
15.6.4	Establishing the required hydraulic circuits	15 - 60
15.6.5	Carrying out emergency operation	15 - 64
15.6.6	After emergency operation	15 - 66
15.6.7	Emergency supply of another crane	15 - 67

41005067

15

Malfunctions during crane operation

15.1

Emergency stop switch



Risk of overloading if used improperly

Only actuate the emergency stop switch if it is no longer possible to stop the crane movements with the normal operating elements. The emergency stop switch stops the crane movements suddenly. This may overload the truck crane, e.g. in the event of high working speeds and large working radiuses.

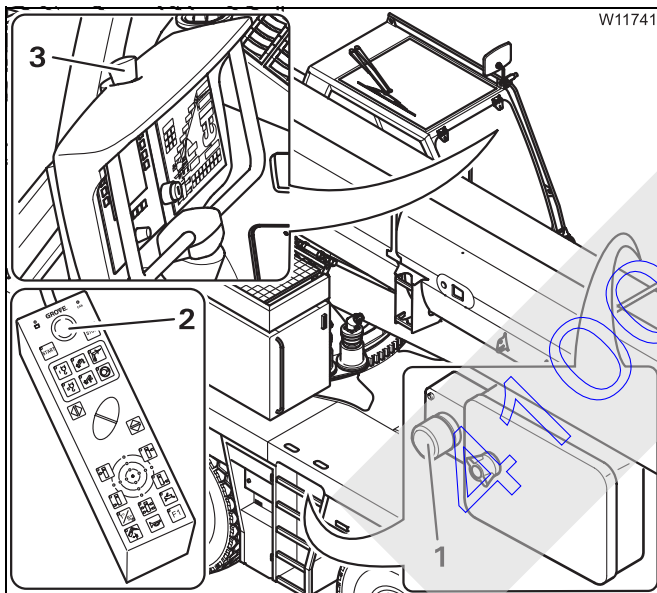

- Stop all crane movements.

Four emergency stop switches are provided for an emergency:

- 1 On the carrier
- 2 On the hand-held control
- 3 In the crane cab

- Press one of the emergency switches (1), (2) or (3). The switch engages.

The engine goes out.

After activating an emergency stop switch;

- *Resetting the emergency stop switch, p. 4 - 22.*



The battery master switch cannot be used as an emergency stop switch for the engine. The engine continues to run after the battery master switch has been switched off.

Blank page

41005067

15.2

What to do when a malfunction occurs during crane operation

If a malfunction occurs:

- Keep calm.



Risk of accidents when carrying out repairs with loads lifted

Repairs must not be carried out as long as a load is lifted.

Always try to lower the load before carrying out repairs.

Only properly qualified personnel may perform crane movements with the solenoid valves.

Load can be lowered

- Set down the load. Retract the main boom completely and set it down on the main boom rest.

If it becomes necessary to override the SLI, observe all of the information in the section *SLI override*, p. 12 - 38.



Risk of accidents due to overridden or faulty SLI

You may only override the SLI if it becomes absolutely necessary in the event of an emergency. This is to put the truck crane into a safe condition in the event of a malfunction. In this case, do not perform any movements that would increase the load moment.

If it is no longer possible to operate the crane from the crane cab, you can use the emergency activation, if necessary;

- ▣▣▣▣ *Emergency operation with the hand-held control*, p. 15 - 51,
- ▣▣▣▣ *Hydraulic emergency operation*, p. 15 - 57

- Lock the crane cab to prevent unauthorized use. Remove the ignition key and lock away the hand-held control.
- Inform your supervisor.
- Try to eliminate the malfunction. Inform **CraneCARE** if you cannot eliminate the malfunction.

Load cannot be lowered

- Secure the danger zone using cordons and warning signs.
- Notify **CraneCARE**.

Blank page

41005067

15.3

Fuses

The fuses are located in different places on the superstructure:

- on the turntable,
- in the crane cab,
- on the SLI.

Notes on changing fuses

The positions of the fuses, their designations and which functions are protected by the respective fuses are shown in the following sections.

- Switch off the ignition whenever a fuse has to be replaced.

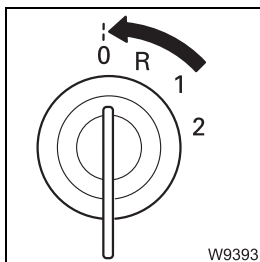

Risk of damage when the ignition is switched on

Switch off the ignition whenever a fuse has to be replaced. In this way you can prevent the new fuse from being damaged by the increased starting current immediately after inserting it.



Risk of damage due to overloading

Replace blown fuses only with new fuses of the same amperage. In this way, you can prevent parts from being overloaded and damaged or the fuse from being immediately damaged again.

Notify *CraneCARE* if a fuse of the same amperage blows again after turning on the ignition.



Danger of fire

Never repair a blown fuse with other electrically conductive materials.

15.3.1 Fuses on the turntable

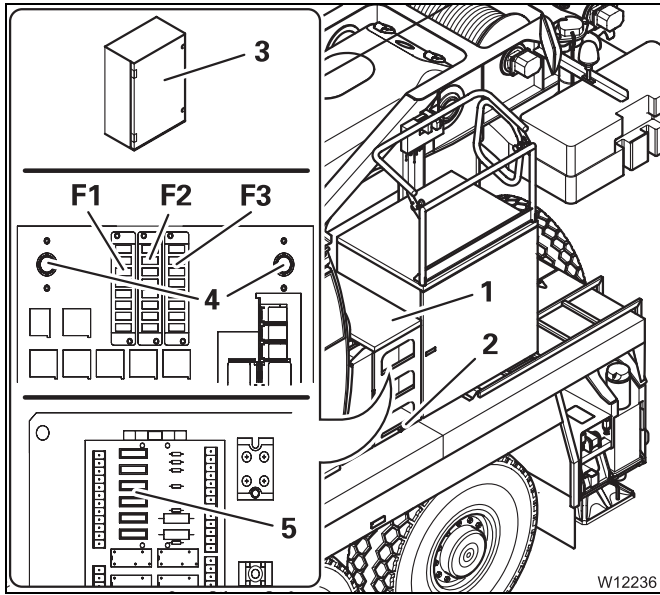

- Undo the screw (2) and remove the access ladder (1).
- Open the distribution box (3). We have fuse groups **F1** and **F2**, fuse group **F3** is not assigned.
- Undo the screws (4) and fold the plate down. There are other fuses on the circuit board (5).

Close the distribution box after the inspection and fasten the access ladder.

- Observe the instructions regarding fuse changes; → p. 15 - 5.

Fuse groups F1/F2

The following tables show the designations of the individual fuses, including their amperage and functions.

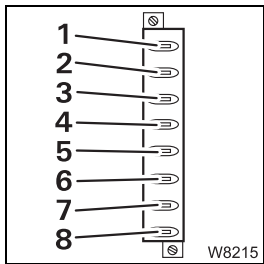

The designations 1 to 8 in the tables correspond to the order from top to bottom (fuse 1 is the top fuse).

Designation	Amperage (A)	Function
F1/1	20	ESX0 control unit I/O-3 circuit board
F1/2	20	ESX1 control unit I/O-4 circuit board
F1/3	10	Central lubrication, lattice extension
F1/4	10	Alternator, rotating beacon of the superstructure
F1/5	20	Air intake inhibitor
F1/6	5	Air intake inhibitor
F1/7	3	I/O-3 circuit board, I/O-4 circuit board
F1/8	5	Engine E-control (PLD)

Designation	Amperage (A)	Function
F2/1	2	Lifting limit switch
F2/2	20	ESX0 control unit
F2/3	20	ESX1 control unit
F2/4	–	Free
F2/5	20	Engine E-control (PLD)
F2/6	3	Emergency operation with hand-held control
F2/7	20	Oil cooler
F2/8	20	Oil cooler

Fuses on the circuit board

The fuses on the circuit board protect the ECOS control units on the superstructure.

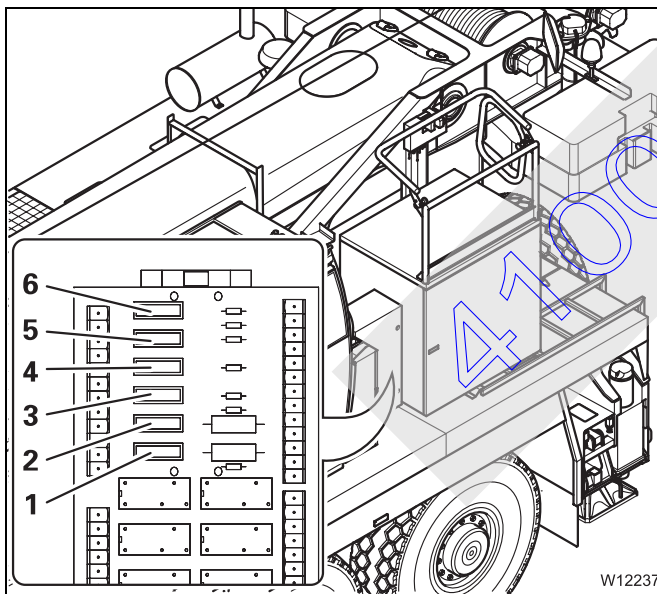

Arrangement of the fuses

Pos.	Designation	Amperage (A)
1	ESX 1 D+	3
2	ESX 1 UE	3
3	ESX 1 8.5 V	2
4	ESX 0 D+	3
5	ESX 0 UE	3
6	ESX 0 8.5 V	2

15.3.2

Fuses in the crane cab

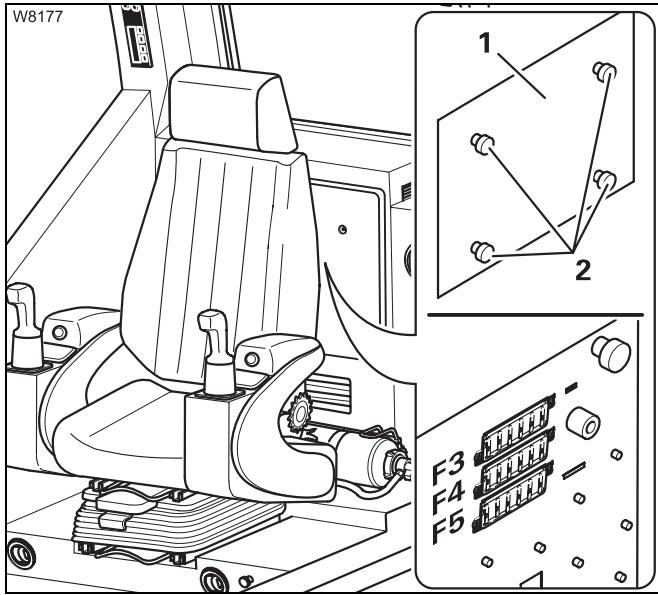

- Undo the screws (2) and remove the cover (1).

The fuse groups **F3**, **F4** and **F5** consist of eight fuses each.

The following tables show the designations of the individual fuses, including their amperage and functions.

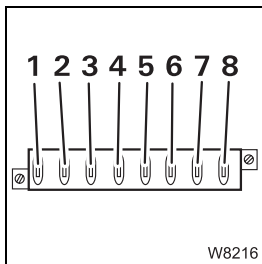

The designations 1 to 8 in the tables correspond to their order from left to right (fuse 1 is always the left fuse).

- Observe the instructions regarding fuse changes; ►► p. 15 - 5.

Designation	Amperage (A)	Function
F3/1	3	ESX2 control unit ECOS control unit supply
F3/2	2	8.5V protection for ESX2 control unit
F3/3	10	SLI and SLI control unit supply
F3/4	10	Controlling the crane cab seat – version 2
F3/5	20	ESX2 control unit Parking brake
F3/6	5	ESX2 control unit ECOS control unit supply
F3/7	5	Control lever supply
F3/8	5	Engine electronics (ADM)

Designation	Amperage (A)	Function
F4/1	10	Engine electronics (ADM)
F4/2	10	24 V / 12 V voltage transformer Crane cab lighting Air traffic control light Radio
F4/3	3	Engine electronics diagnostics plug
F4/4	25	Air-conditioning system
F4/5	–	Free
F4/6	15	Heating system
F4/7	–	Free
F4/8	–	Free

Designation	Amperage (A)	Function
F5/1	15	Spotlights
F5/2	15	Spotlights
F5/3	15	Windscreen wiping and washing system, cigarette lighter
F5/4	10	Heating system
F5/5	5	Instrument panel lighting
F5/6	5	Voltage indicator lamp Engine electronics diagnostics plug
F5/7	10	Heater fan
F5/8	–	Free

15.3.3

Fuses in the battery box

Fuses F10 to F13 are contained in the battery box.



Danger due to lead and lead compounds of batteries

Battery poles, battery terminals and parts of the battery itself contain lead and lead compounds. Wash your hands after working on these parts or in these areas.

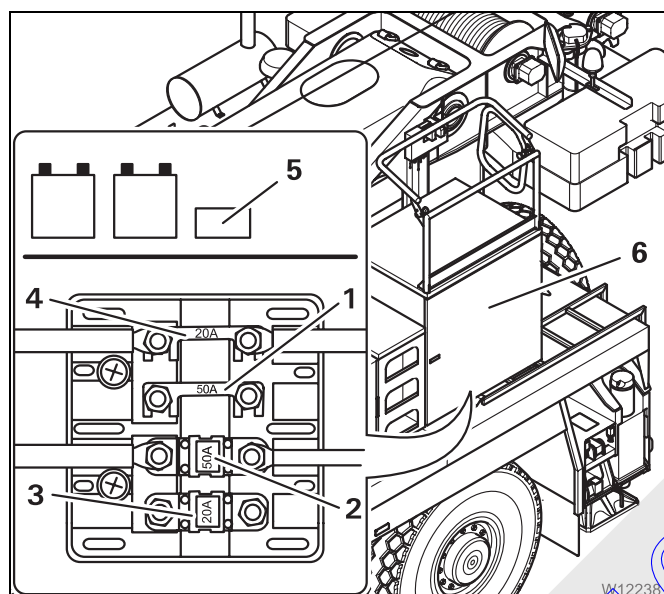

- Open the door (6).
- Remove the lid from the terminal box (5).
- 1 Fuse F10
- 2 Fuse F11
- 3 Fuse F12
- 4 Fuse F13
- Observe the instructions regarding fuse changes; ► p. 15 - 5.

Designation	Amperage (A)	Function
F10	50	Free
F11	50	Superstructure central fuse
F12	20	Free
F13	20	Preliminary fuse for auxiliary heater timer

15.3.4 SLI fuses

When a fuse is blown, a corresponding error code is displayed; *Table of error codes*, p. 15 - 28.

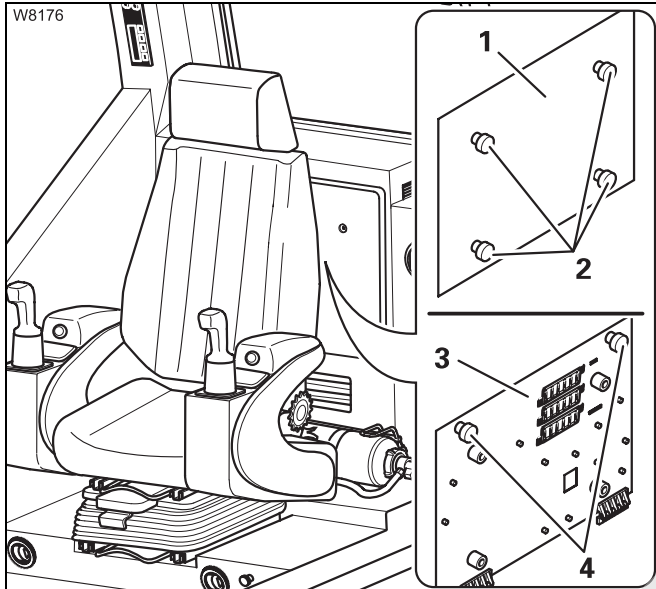

- Undo the screws (2) and remove the cover (1).
- Undo the screws (4) and fold down the plate (3) to the front.
- Observe the instructions regarding fuse changes; p. 15 - 5

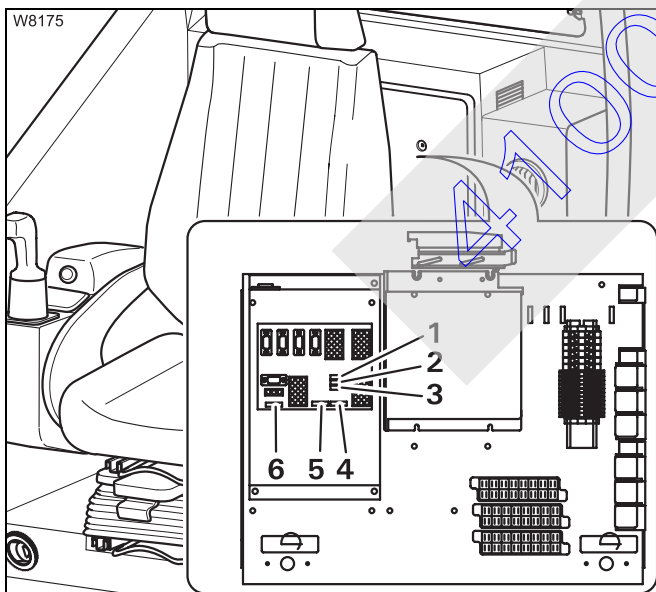

Arrangement of the fuses on the SLI control unit.

Pos.	Designation	Amperage (A)
1	Fuse F1	5
2	Fuse F2	5
3	Fuse F3	5
4	Fuse F11	5
5	Fuse F12	5
6	Fuse F6	5

Blank page

41005067

15.4

Finding and eliminating malfunctions

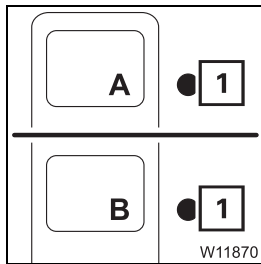

This section does not include all malfunctions. When a lamp (1) lights up;
 ■■■► *Warning submenu*, p. 12 - 102.

15.4.1

Malfunctions on the engine

Malfunction	Cause	Remedy
Engine will not start – starter does not turn	Battery master switch is switched off	Switch on the battery master switch; ■■■► p. 11 - 7
	Ignition off	■■■► <i>Switch on the ignition</i> , p. 11 - 8
	Fuses F1/8, F2/5, F3/8, F4/1 faulty	Replace blown fuses; ■■■► p. 15 - 5
	Hand-held control connected or bridging plug not inserted	Disconnect hand-held control or insert bridging plug; ■■■► p. 13 - 20
	Emergency stop switch actuated	■■■► <i>Resetting the emergency stop switch</i> , p. 11 - 20
Engine will not start – starter turns	Ignition in the driver's cab switched on	Switch off the ignition in the driver's cab; ■■■► p. 4 - 21
	Batteries insufficiently charged	Charge batteries
	Fuel tank empty	1. Refuel; ■■■► p. 11 - 5 2. Bleed the fuel system; ■■■► <i>Maintenance manual</i> ■■■► <i>Separate engine operating instructions, provided by the manufacturer</i>
	Air intake inhibitor closed	■■■► <i>Releasing the air intake inhibitor</i> , p. 11 - 21





Malfunction	Cause	Remedy
Coolant temperature too high	Coolant level too low	Top up coolant; ■■■► <i>Maintenance manual</i>
	Outer surface of heat exchanger dirty	Clean outer surface of heat exchanger
	V-belt of coolant pump at engine loose	Tension V-belt; ■■■► <i>Separate engine operating instructions, provided by the manufacturer</i>
Engine cannot be turned off with ignition key	Malfunction in the electronics	Switch off the engine using the emergency stop device; ■■■► p. 11 - 20
Engine diagnostics plug not working	Fuses F4/3, F5/6 blown	Replace blown fuses; ■■■► p. 15 - 8
The engine performance is reduced	The coolant is too hot or another malfunction. The engine is not switched off to ensure the load can be lowered and the truck crane can be unrigged.	Coolant too hot: wait until the coolant has cooled down – the performance will increase again Other malfunction: CraneCARE must be notified

41005061



15.4.2

Malfunctions on the main hoist / auxiliary hoist

Malfunction	Cause	Remedy
Main hoist not working or malfunctioning	Hoist off, lamp in button lights up dimly	▣▣▣▣ <i>Switching on the main hoist</i> , p. 12 - 46, ▣▣▣▣ <i>Switching on the auxiliary hoist</i> , p. 12 - 48
	Dead man's switch not actuated	Press dead man's switch
	Emergency stop switch actuated	▣▣▣▣ <i>Resetting the emergency stop switch</i> , p. 4 - 22
	Fuses F1/1, F2/3, F3/1, F3/2, F3/5, F3/6§ blown	Replace blown fuse; ▣▣▣▣ p. 15 - 5
	Fuse blown on circuit board	Replace blown fuse; ▣▣▣▣ p. 15 - 7
	Control unit faulty, error message displayed	Acknowledge error message once; ▣▣▣▣ p. 15 - 33 – if it occurs again, notify CraneCARE .
	Fuse F3/7 blown	Replace blown fuse; ▣▣▣▣ p. 15 - 8
Only the lifting function works	Lowering limit switch activated	Leave the shutdown range and lift the main hoist
Only the lowering function works	Lifting limit switch approached, lamp  lights up	Leave the shutdown range and lower the main hoist
	SLI shutdown, lamp  lights up	Leave the shutdown range; ▣▣▣▣ p. 12 - 36
	Fuse F3/3 blown	Replace blown fuse; ▣▣▣▣ p. 15 - 8
Lifting, lowering or high-speed mode function not working	Function disabled by ECOS	If required, acknowledge error message once and briefly turn off the ignition – if it occurs again, notify CraneCARE .
No lifting function	Fuse SLI F6 blown	Replace blown fuse; ▣▣▣▣ p. 15 - 11
	Fuse F3/3 blown	Replace blown fuse; ▣▣▣▣ p. 15 - 8
Lifting or lowering is either not possible at all or only at a low speed	Speed limited	Increase limit; ▣▣▣▣ p. 12 - 96
Lifting or lowering function cannot be deactivated	ECOS malfunction	Actuate emergency stop switch; ▣▣▣▣ p. 15 - 1
No response to control lever movements	ECOS malfunction concerning operating elements in the crane cab	Unrig using hand-held control; ▣▣▣▣ p. 15 - 51



15.4.3

Malfunctions on the derricking gear

Malfunction	Cause	Remedy
Derricking gear not working or malfunctioning	Derricking gear off, lamp in button lights up dimly	Switching on the derricking gear; ■■■▶ p. 12 - 54
	Dead man's switch not actuated	Press the dead man's switch.
	Emergency stop switch actuated	■■■▶ <i>Resetting the emergency stop switch</i> , p. 4 - 22
	Fuses F1/1, F1/2, F2/2, F2/3, F3/1, F3/2, F3/5 F3/6 blown	Replace blown fuse; ■■■▶ p. 15 - 5
	Fuse blown on circuit board	Replace blown fuse; ■■■▶ p. 15 - 7
	Control unit faulty, error message displayed	Acknowledge error message once; ■■■▶ p. 15 - 33 – if it occurs again, notify CraneCARE .
	Fuse F3/7 blown	Replace blown fuse; ■■■▶ p. 15 - 6
Lowering function not working	Lifting limit switch approached, lamp  lights up	Leave the shutdown range and lower the auxiliary hoist
	SLI shutdown, lamp  lights up	Leave the shutdown range; ■■■▶ p. 12 - 36
	Fuse F3/3 blown	Replace blown fuse; ■■■▶ p. 15 - 8
Derricking function not working	Function disabled by ECOS	If required, acknowledge error message once and briefly turn off the ignition – if it occurs again, notify CraneCARE .
	Fuse SLI F6 blown	Replace blown fuse; ■■■▶ p. 15 - 11
	Fuse F3/3 blown	Replace blown fuse; ■■■▶ p. 15 - 8
Derricking not possible, or only at low speed	Speed limited	Increase limit; ■■■▶ p. 12 - 96
Derricking cannot be switched off	ECOS malfunction	Actuate emergency stop switch; ■■■▶ p. 15 - 1
No response to control lever movements	ECOS malfunction concerning operating elements in the crane cab	Unrig using hand-held control; ■■■▶ p. 15 - 51

15.4.4

Malfunctions in the telescoping mechanism

Malfunction	Cause	Remedy
Telescoping mechanism not working or malfunctioning	Telescoping mechanism off, lamp in button lights up dimly	▣▣▣▣ <i>Switching on the telescoping mechanism</i> , p. 12 - 65
	Dead man's switch system not actuated	Press dead man's switch
	Emergency stop switch actuated	▣▣▣▣ <i>Resetting the emergency stop switch</i> , p. 11 - 20
	Fuses F1/1, F1/2, F1/7, F2/2, F2/3, F3/1, F3/2, F3/5, F3/6 faulty	Replace blown fuse; ▣▣▣▣ p. 15 - 5
	Fuse blown on circuit board	Replace blown fuse; ▣▣▣▣ p. 15 - 7
	Control unit faulty, error message displayed	Acknowledge error message once; ▣▣▣▣ p. 15 - 33 – if it occurs again, notify CraneCARE .
	Fuse F3/7 blown	Replace blown fuse; ▣▣▣▣ p. 15 - 8
Telescopic section and telescoping cylinder locking / unlocking function not working	Faulty valve	Note down error code ▣▣▣▣ p. 15 - 33 and notify CraneCARE
Extending function not working	Fuse F3/3 blown	Replace blown fuse; ▣▣▣▣ p. 15 - 8
	SLI shutdown, lamp  lights up	Leave the shutdown range; ▣▣▣▣ p. 12 - 36
	Lifting limit switch approached, lamp  lights up	Leave the shutdown range, retract boom
Retracting function not working	Insufficient lubrication	Lubricate main boom; ▣▣▣▣ <i>Maintenance manual</i>
	Main boom is not steep enough	Leave the shutdown range and raise the boom.
Telescopic section cannot be operated by moving the control lever	Telescopic section locked	▣▣▣▣ <i>Unlocking the telescopic section</i> , p. 12 - 75
	Telescoping cylinder unlocked	▣▣▣▣ <i>Locking the telescoping cylinder</i> , p. 12 - 74
Telescopic section / telescoping cylinder locking function not working	Fault in hydraulics / electrical system	Note down error codes ▣▣▣▣ p. 15 - 18, ▣▣▣▣ p. 15 - 32 and notify CraneCARE



Malfunction	Cause	Remedy
Telescoping function not working	Function disabled by ECOS	If required, acknowledge error message once and briefly turn off the ignition – if it occurs again, notify CraneCARE .
	Fuse SLI F6 blown	Replace blown fuse; ■■■▶ p. 15 - 11
	Fuse F3/3 blown	Replace blown fuse; ■■■▶ p. 15 - 8
Telescoping not possible, or only at low speed	Speed limited	Increase limit; ■■■▶ p. 12 - 96
Telescoping cannot be switched off	ECOS malfunction	Actuate emergency stop switch; ■■■▶ p. 15 - 1
The main boom can no longer be telescoped; the telescoping cylinder can no longer be moved	The hydraulic supply is interrupted	Retract the telescopic section by means of mechanical emergency operation; ■■■▶ p. 15 - 36
No response to control lever movements	ECOS malfunction concerning operating elements in the crane cab	Unrig using hand-held control; ■■■▶ p. 15 - 51

Telescoping mechanism error messages

If ECOS disables the telescoping mechanism, the following display is shown in the *Telescoping* submenu.

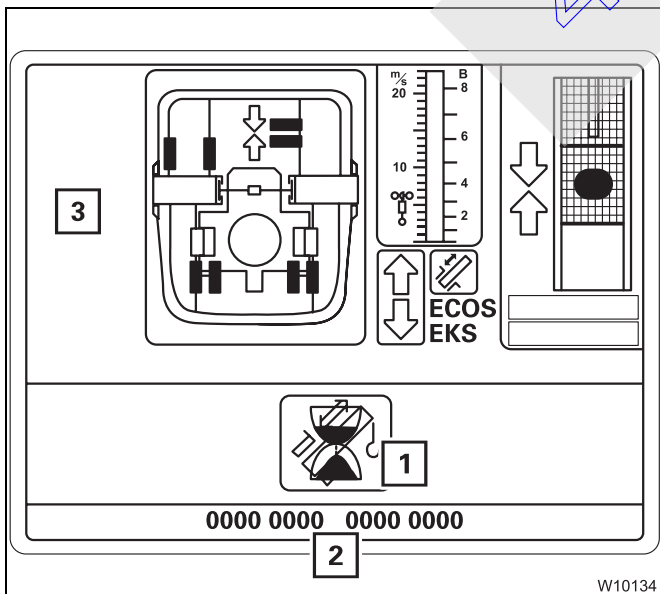

- All the symbols (3) for operation disappear – the corresponding buttons are disabled.
- The display (1) appears.
- An error code(2) is indicated.
- Always note down this error codes before contacting **CraneCARE**.

The display (1) shows the symbol for the current status:



Waiting

The symbol usually disappears shortly after switching on the ignition. If the symbol does not go out or is displayed while operating the crane, this may be due to an SLI shutdown or blown F1/2 fuse. Contact **CraneCARE** if the these causes do not apply.



Telescope status divergence

ECOS has detected a difference between the displayed and the current telescoping. Enter the current telescoping procedure;  p. 15 - 49.



Emergency program access

The telescoping mechanism can only be operated with the emergency program;  p. 15 - 39.

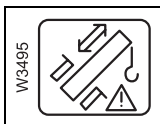

Emergency program

The *Telescoping* emergency program is open;  p. 15 - 39.



Not active

Contact **CraneCARE** if this status is still displayed after repeatedly switching on the ignition.

41005067

15.4.5 Malfunctions on the slewing gear

Malfunction	Cause	Remedy
Slewing gear not functioning	Slewing gear off, lamp in button lights up dimly	Switch on the slewing gear; p. 12 - 88
	Houselock switched on	<i>Switching the houselock on / off</i> , p. 12 - 14
	Dead man's switch system not actuated	Press dead man's switch
	Emergency stop switch actuated	<i>Resetting the emergency stop switch</i> , p. 4 - 22
	Fuses F1/1, F1/2, F2/2, F2/3, F3/1, F3/2, F3/5, F3/6 blown	Replace blown fuse; p. 15 - 5
	Fuse blown on circuit board	Replace blown fuse; p. 15 - 7
	Control unit faulty, error message displayed	Acknowledge error message once; p. 15 - 33 – if it occurs again, notify CraneCARE .
	Fuse SLI F6 blown	Replace blown fuse; p. 15 - 11
	Fuse F3/3 blown	Replace blown fuse; p. 15 - 8
Slewing function not working	Enter SLI code for the 0° to the rear position	Enter SLI code for a slewing range
	Counterweight lifting cylinder not fully retracted	Fully retract lifting cylinder; p. 13 - 73
	Function disabled by ECOS	If required, acknowledge error message once and briefly turn off the ignition – if it occurs again, notify CraneCARE .
Slewing only possible in one direction	Shutdown angle of a limited slewing range reached (additional equipment)	Enter the SLI code for a slewing range of 360° or slew in the opposite direction to leave the shutdown angle
Slewing not possible or only at low speed	Speed limited	Increase limit; p. 12 - 96
Slewing cannot be switched off	ECOS malfunction	Actuate emergency stop switch; p. 15 - 1
No response to control lever movements	ECOS malfunction concerning operating elements in the crane cab	Unrig using hand-held control; p. 15 - 51

15.4.6

Malfunctions on the counterweight hoist unit

Malfunction	Cause	Remedy
Counterweight hoist unit not working	Emergency stop switch actuated	▣▣▣▣▶ <i>Resetting the emergency stop switch</i> , p. 11 - 20
	Fuse F1/1, F1/7	Replace blown fuse; ▣▣▣▣▶ p. 15 - 6
	Control unit faulty, error message displayed	Acknowledge error message once; ▣▣▣▣▶ p. 15 - 33 – if it occurs again, notify CraneCARE .
	Function disabled by ECOS	If required, acknowledge error message once and briefly turn off the ignition – if it occurs again, notify CraneCARE .
Error symbol (!) is displayed	Electronics has identified an error	
Retract / extend lifting cylinder not working	Superstructure in the <i>intermediate position</i> rigging range	Slew to <i>Move lifting cylinders</i> or <i>Lift / lower counterweight</i> position; ▣▣▣▣▶ p. 10 - 65
Extend lifting cylinder not working	Superstructure outside of rigging range	Slew into the rigging range
	Counterweight rigged and <i>Move lifting cylinders</i> position reached	Slew to <i>Lift / lower counterweight</i> position
	Counterweight unrigged and <i>Lift / lower counterweight</i> position reached	Slew to <i>Move lifting cylinders</i> position
Retract / extend lifting cylinder and slewing not working	Automatic mode cancelled	Meet requirements for automatic mode; ▣▣▣▣▶ p. 13 - 76

15.4.7 Malfunctions in the hydraulic system / hydraulic oil cooler

Malfunction	Cause	Remedy
Hydraulic oil temperature above 80 °C (176 °F), fan in the hydraulic oil cooler running	Hydraulic system is under extreme strain	Stop working with the crane and keep the engine running until the oil has cooled down
Hydraulic oil temperature above 80 °C (176 °F), fan in the hydraulic oil cooler not running	Fuse F2/7, F2/8 blown.	Stop crane operation and replace blown fuse; ■■■▶ p. 15 - 6
	Faulty temperature sensor in the circuit of the hydraulic system, error message displayed	Have the temperature sensor replaced



15.4.8 Malfunctions when inclining the crane cab

Malfunction	Cause	Remedy
Crane cab inclination function not working	Fuses F1/1, F1/2, F1/7, F2/3 faulty	Replace blown fuse; ■■■▶ p. 15 - 6

15.4.9 Malfunctions when operating with the hand-held control

Malfunction	Cause	Remedy
CAN lamp flashes or stays off after connecting the hand-held control	A bridging plug is not inserted on another socket	Insert bridging plug; ■■■▶ p. 13 - 20
	Fuse F2/6 blown	Replace blown fuse; ■■■▶ p. 15 - 6
Motor will not start	Ignition in the driver's cab switched on	Switch off the ignition in the driver's cab; ■■■▶ p. 4 - 21
Pre-selected function cannot be performed	Another function has been pre-selected	Pre-select the desired function
Operation not possible	Malfunction in the control system	CraneCARE must be notified





15.4.10 Malfunctions when driving from the crane cab

Malfunction	Cause	Remedy
The transmission, the differential locks and the separate steering do not respond to the operating elements – symbols grey	Carrier ignition switched off	Switch on carrier ignition; ▣▣▣▣▶ p. 14 - 8
	Ignition key in driver's cab not in position 1	Turn the ignition key in the driver's cab to position 1; ▣▣▣▣▶ p. 14 - 8
	Parking brake was released before the <i>Driving</i> submenu was opened	Apply parking brake
	Malfunction in the engine electronics – symbol  red	CraneCARE must be notified
The transmission and the differential locks do not respond to the operating elements	Supply pressure too low, symbol  red	Let the engine for driving run until the supply pressure has been built up – symbol  grey
Button for separate steering has no function	Separate steering switched off	Switch on the separate steering; ▣▣▣▣▶ p. 14 - 5
Accelerator and several operating elements in the submenu have no function	Seat contact switch off	Sit down or press dead man's switch
Error symbol (!) is displayed with differential locks or separate steering	An illogical switching state was recorded	If required, acknowledge error message once and briefly turn off the ignition – if it occurs again, notify CraneCARE .

If this table does not help to remedy the malfunction;

- ▣▣▣▣▶ *Malfunctions on the transmission*, p. 7 - 25,
- ▣▣▣▣▶ *Malfunctions in the differential locks*, p. 7 - 28,
- ▣▣▣▣▶ *Steering malfunctions*, p. 7 - 27,
- ▣▣▣▣▶ *Malfunctions on the engine*, p. 7 - 23.

15.4.11 Malfunctions on the outriggers

Malfunction	Cause	Remedy
Support cylinders and beams can neither be extended nor retracted and the inclination indicator does not work	Driver's cab: fuses A2F3, A3F3, A3F14	Replace the defective fuses;  p. 7 - 18,
When operating with the hand-held control	Driver's cab: fuse A2F4 blown	Replace blown fuse;  p. 7 - 20
When operating from the crane cab	Hand-held control connected to the superstructure or a bridging plug not inserted	Disconnect hand-held control or insert bridging plug;  p. 13 - 20
When operating from the operating elements	Display fields switched off	Switch on display fields;  p. 13 - 29
	Hand-held control connected to the superstructure or a bridging plug not inserted	Disconnect hand-held control or insert bridging plug;  p. 13 - 20
None of the specified causes apply	Solenoid valves are not switching electrically	CraneCARE must be notified

41005064

15.4.12 Troubleshooting on the SLI

This section contains general malfunctions which are not displayed on the *SLI* control unit as well as malfunctions which prompt an error display on the *SLI* control unit.



Risk of accidents

Immediately stop operating the crane if an error message is displayed. The *SLI* may only be repaired by trained, qualified personnel.



Risk of accidents in the event of a faulty or overridden *SLI*

In the event of a faulty *SLI*, first try to correct the error with the information in this section. Only override the *SLI* if it becomes absolutely necessary in order to lower the load in the event of an emergency.

Do not carry out any movements which increase the load moment in the event of a faulty or overridden *SLI*.

If the *SLI* is overridden, the crane operations are not monitored and no shutdown procedures are initiated when leaving the working range.

General malfunctions

Malfunction	Cause	Remedy
SLI not working – dark displays, no buzzer tone	Power supply not switched on	Switch on the ignition
	Fuse F3/3 blown	Replace the blown fuse; ■■■► p. 15 - 6.
	Fuse <i>SLI</i> F6 blown	Replace the blown fuse; ■■■► p. 15 - 11.



Error messages

If the SLI detects an error, an error message is shown on the *SLI* control unit. There are:

- error messages without shutdown,
- error messages with shutdown.



Risk of accidents

Immediately stop operating the crane if an error message is displayed. The SLI may only be repaired by trained, qualified personnel.

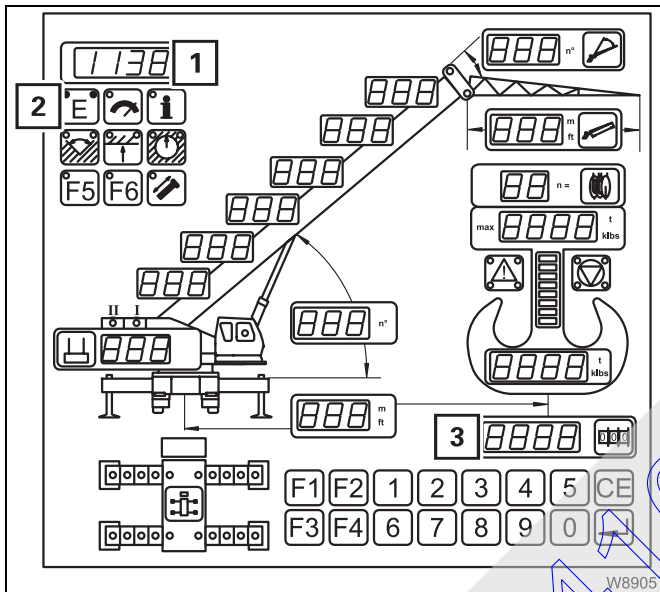

Error message without shutdown

- The buzzer tone sounds once.
- Both lamps in the button (2) light up.
- The display (1) shows an error code, e.g. **1138**.

When the display (3) is switched to input mode, you must press the button (2) once to show the error code.

You can have all existing error messages displayed by repeatedly pressing the button (2).

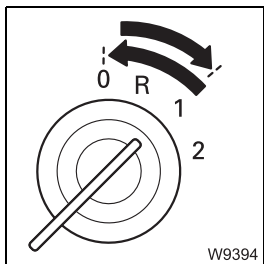

Try to remedy the error by turning off the ignition and turning it on again after about 15 seconds.

If the error is displayed again, check whether the error code is contained in the *Error codes* tables. These tables contain information on how to remedy errors; see p. 15 - 28.

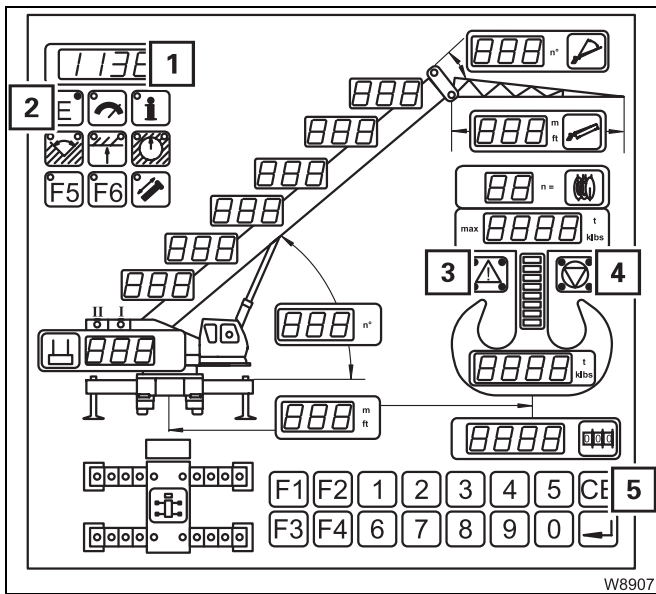

Error message with shutdown

- All crane movements are shut down.
- A continuous buzzer tone sounds.
After five seconds, you can switch off the buzzer tone using the button (5).
- Lamps (3) and (4) light up.
- Both lamps in the button (2) light up.

The display (1) shows the error codes in the same way as with error messages without a shutdown.

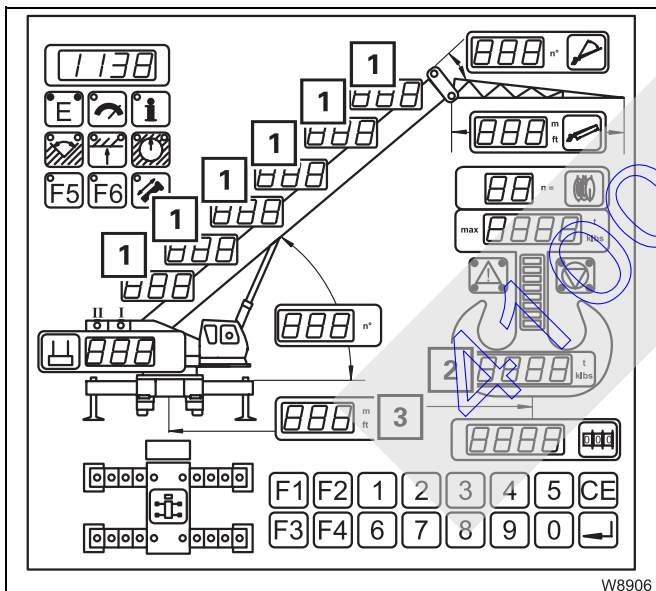

Some error messages with a shutdown have additional displays.

Flashing displays:

- either display (1).
- or displays (2) and (3).
- or displays (1) through (3).

When values flash, the difference between the calculated and measured value is too large.

If the error message 3033 is displayed;

▣▣▣▣ Table of error codes, p. 15 - 28.



Table of error codes

The following table contains a number of error codes, their causes and possible remedies.

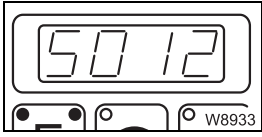

An error code consists, from left to right, of a one-digit number (e.g. **5**), a two-digit number (e.g. **01**) and a one-digit number (e.g. **2**).

- Check whether the table contains the displayed error code. If the information in the table does not help to remedy an error, note the error code(s) down and contact **CraneCARE**.

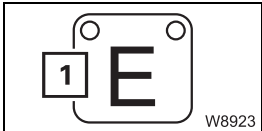

When all errors are remedied, the lamps in the button (1) go out.

Error code			Cause	Remedy
1	01	1...7	Error pressure sensor 1, lower chamber	Switch off pressure sensor 1; ■■■▶ p. 15 - 31
1	01	8	Pressure sensor 1 switched off	Have malfunction rectified
1	02	1...7	Error pressure sensor 2, lower chamber	Switch off pressure sensor 2; ■■■▶ p. 15 - 31
1	02	8	Pressure sensor 2 switched off	Have malfunction rectified
1	04	1...7	Error angle sensor 1, Main boom	Switch off pressure sensor 1; ■■■▶ p. 15 - 31
1	04	8	Angle sensor 1 switched off	Have malfunction rectified
1	05	1...7	Error angle sensor 2, Main boom	Switch off pressure sensor 2; ■■■▶ p. 15 - 31
1	05	8	Angle sensor 2 switched off	Have malfunction rectified
1	13 to 21	1	Lattice extension not connected or sensor faulty	Electrically connect the lattice extension; if the error persists, inform CraneCARE
3	03	3	Comparison of telescoping diagram between crane control and SLI resulted in differences	Compare the actual telescoping position with the values on the <i>Crane control</i> display and, if necessary, re-enter the telescoping position. Accept the telescoping data from the crane control if incorrect telescoping is displayed on the SLI: 1. Press the buttons F3 + CE once. The SLI shows the new values. 2. Acknowledge the error

Error code			Cause	Remedy
8	01	1	Reeving or SLI code not yet confirmed	<ul style="list-style-type: none"> ▣▣▣▣► <i>Confirming the reeving</i>, p. 12 - 25 ▣▣▣▣► <i>Confirming the SLI code</i>, p. 12 - 28.
8	02	2	SLI is overridden	Cancel the override; ▣▣▣▣► p. 12 - 38.
8	03	3	Slewing gear switched on with SLI code for working position 0° , 180° or <i>Free-on-wheels</i>	Lock turntable.
8	14	1	Maximum permissible overall height exceeded ¹⁾	Retract or lower.
8	14	2	Maximum permissible overall working radius exceeded ¹⁾	Raise or retract.
8	14	3	Maximum permissible overall slewing range exceeded ¹⁾	Slew into a permissible working range.
8	14	4	Shutdown area of a monitored object reached ¹⁾	Move into a permissible working range.

¹⁾ with working range limiter switched on

41005061

Switching off the sensor / tachogenerator

For values measured twice, you can switch off the faulty sensor / tachogenerator in the case of an error and continue working with one sensor / tachogenerator for a short time.



Danger due to failure of the SLI

Have the error rectified before the next crane job.

By doing this, the crane can then still be unrigged with SLI monitoring if the second sensor / tachogenerator fails.



- Press button **E** repeatedly until the error for the faulty sensor / tachogenerator is displayed, e.g. **1021** for pressure sensor 2.

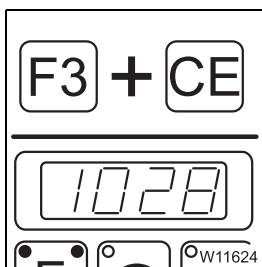

- Press the button **F3** and additionally the button **CE** once.

The faulty sensor / tachogenerator is switched off and the corresponding error is displayed, e.g. **1028** for pressure sensor 2.

When the ignition is switched on again, the shutdown is cancelled and the error occurs again, possibly with a different last digit, e.g. 1025.

After switching off the faulty sensor / tachogenerator, you should check whether the remaining sensor / tachogenerator is functioning correctly.



Risk of accidents due to defective functioning

After switching off the faulty sensor / tachogenerator, only begin crane operation if the remaining sensor / tachogenerator is displaying correctly. In this way, you prevent the SLI from not switching off when leaving the working range and the truck crane overturning as a result.

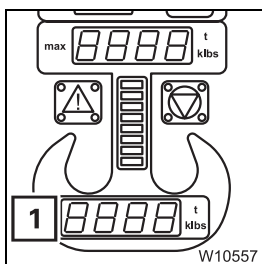

Checking the pressure sensor function

- Lift the hook block without a load.
- Check whether the display (1) indicates the approximate weight of the hook block. Weights of the hook blocks; p. 16 - 2.

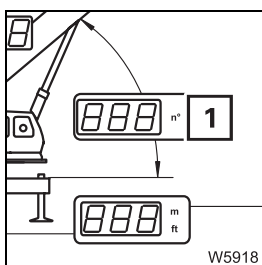

Checking the angle sensor function

- Set down the main boom on the boom rest.
- Check whether the display (1) shows an angle of 0°.

15.4.13 Malfunctions ECOS – superstructure

This section contains general malfunctions, and malfunctions which generate an error display.

ECOS program version

Always note down the number of the program version before notifying *CraneCARE* in the event of a malfunction.

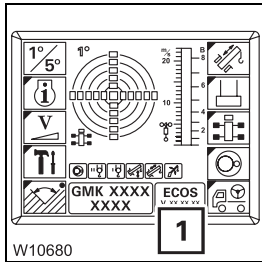



- If required, open the main menu .

The display (1) shows the number of the current program version.

General malfunctions

The following table contains information on finding faults and possible remedial measures.

Malfunction	Cause	Remedy
The ECOS display remains dark although the ignition is switched on	Fuses F1/1, F2/2, F3/1, F3/6 faulty	Replace the blown fuse;  p. 15 - 5.
	Fuses on the circuit board blown	Replace the blown fuse;  p. 15 - 7.



Other malfunctions on the ECOS generate corresponding error messages.

Error messages

If ECOS detects an error, an error message is indicated:

- lamp (1) flashes and
- lamp (2) flashes.

For more information, you must open the *Error* submenu.

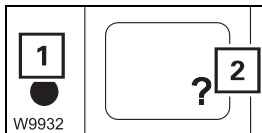
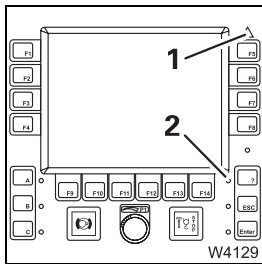

- Press button (2) once. The button is only active when the lamp (1) flashes or lights up.

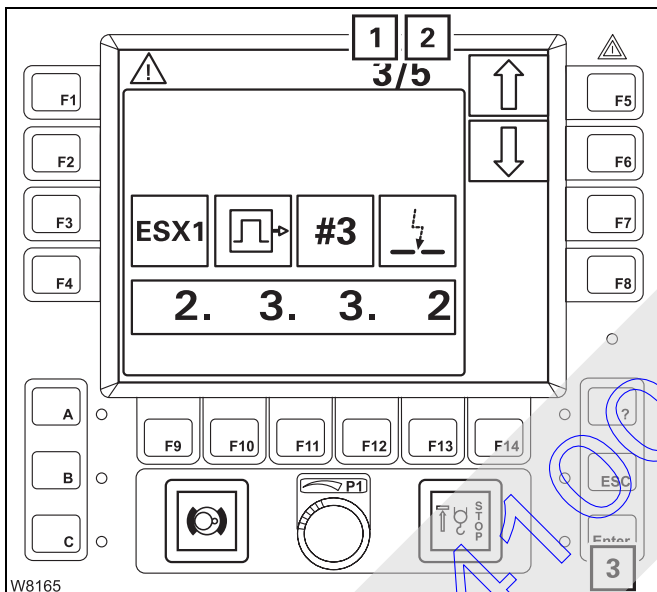

The *Error* submenu opens.

Display (2) shows the error total, and display (1) shows which error is displayed.

3/5, for example, means:

- that error **3** is shown
- there is a total of **5** errors.

If the error shown is not acknowledged, the lamp next to the button (3) lights up.

To acknowledge the error

- Press button (3) once.

If there are further errors, the next error is displayed and can be acknowledged.

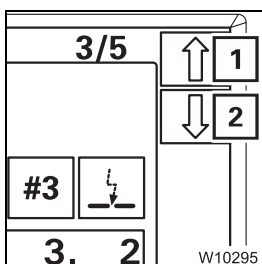



- When all errors have been acknowledged, you can retrieve any pending errors using the buttons next to the symbols (1) and (2).

- 1 Next error
- 2 Previous error

Every time you press, the next error will be displayed.

When you keep a button held down, all errors are shown one after the other continuously.



If not all errors have been acknowledged, the buttons   have no function – the symbols are grey.



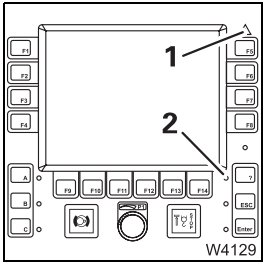

When all error messages have been acknowledged, the displays change:

- lamp (1) lights up and
- lamp (2) lights up.

Both displays start to flash again as soon as a new error occurs.

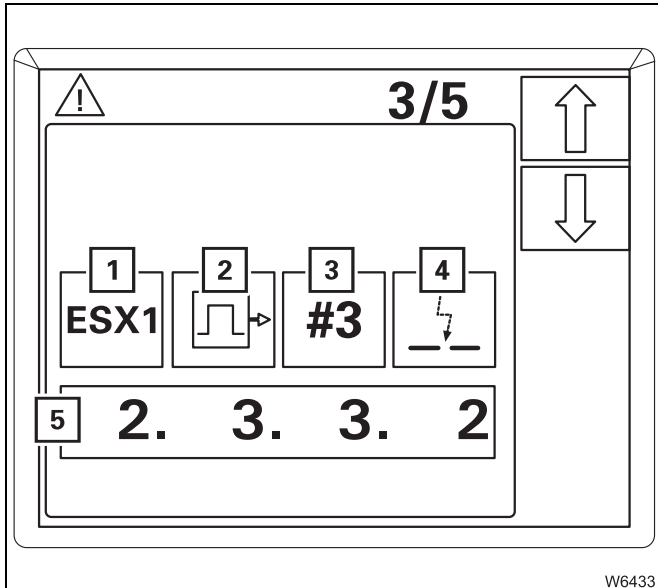

Error message display

Each error is defined by an error code (5) and the symbols (1) to (4).

The symbols stand for:

- 1 the faulty device
- 2 the error group
- 3 the index within the group
- 4 the type of error

The error code (5) consists of 4 digits, e.g. 2332.

- Always note down the error code before contacting **CraneCARE**.

Exiting the submenu



You can exit the *Error* submenu at any time.

- Press button (1) once.

The same menu opens that was open before the *Error* submenu opened.

All errors remain saved until you switch off the ignition, even those errors of which the cause has been eliminated in the meantime. All existing errors are treated as new errors and displayed again after turning on the ignition.

15.5

Emergency operations and programs

This section contains all the information about possible emergency operations and emergency programs. There is:

- a mechanical emergency operation for retracting,
- the *Telescoping emergency program* submenu,
- the entering of the telescoping after an emergency operation and
- the operation of the power units with the hand-held control.

41005067

15.5.1

Mechanical emergency operation for retracting

If you can no longer lock and unlock the telescopic sections from within the crane cab because of a malfunction, you can do so by performing mechanical emergency operations.

In this case you need one or two auxiliary cranes.

In the worst case, emergency operation has to be performed by properly trained personnel, because incorrect operation poses the risk of injury and damage to the main boom.

- Always check the following option first.

Check prior to the emergency operation

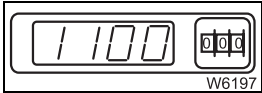

First check whether it is permitted to lower the main boom to a horizontal position with the current telescoping. Proceed as follows:

Enter the current rigging mode on the SLI. The corresponding SLI code according to the *Lifting capacity table* must be displayed.

- Lower the main boom.
- **If the SLI allows the boom to be lowered into a horizontal position**
You can reach the locking points with a ladder and need only one auxiliary crane to telescope the unlocked telescopic sections.
- **If the SLI is deactivated prior to reaching horizontal position**
In order to reach the locking points, you need an auxiliary crane with licensed passenger transportation and a second auxiliary crane to secure and telescope the unlocked telescopic sections.



If it is possible to lower the main boom but there is not sufficient space, you can check whether it is permissible to drive the truck crane in the current rigging mode; ■■■► p. 14 - 1.

For operation with the lattice extension; ■■■► *Operating Instructions Lattice Extension*.

Procedure

Which of the retracting procedures is best in your particular case depends on the conditions on site and on the crane functions that can still be operated.

Select the procedure best suited to your particular case and consult **CraneCARE**.

Mechanical emergency operation

The following requirements must be met before unlocking manually:

- The main boom must be lowered to the horizontal position so that the telescopic section cannot retract by itself.

or

- The telescopic section to be unlocked is secured against retracting by itself by using an auxiliary crane. Telescoping is done with the auxiliary crane.



Risk of accidents due to sudden retraction of a telescopic section

Before unlocking the telescopic section secure it against automatic retraction. In this way, you can prevent the retracting telescopic section from shearing off any of your limbs or the truck crane from being damaged or overturned by the telescopic section suddenly retracting.



If the telescoping cylinder is positioned at a locking point, the corresponding telescopic section cannot be locked or unlocked manually.

There are two M 12 screws for every telescopic section,

- length 150 mm (5.9 in) for telescopic sections I to III,
- length 100 mm (3.9 in) for the other telescopic sections.

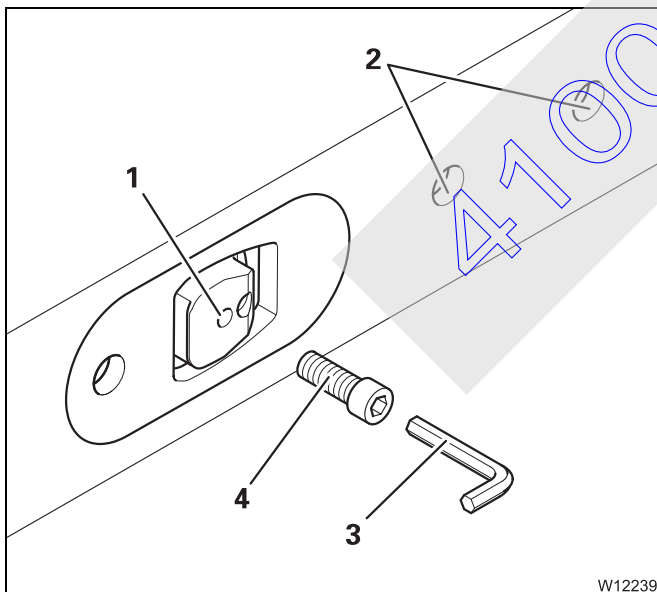

In order to unlock, the screws (4) are screwed into the locking pins (1).

Pins located further inside are reached through the bore holes (2).

You will need a suitable socket wrench (3), at least 200 mm (7.9 in) long.



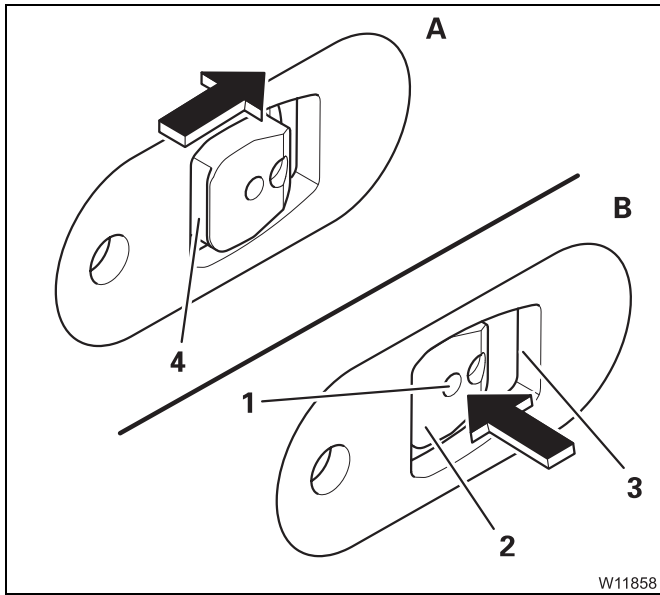

Unlocking telescopic sections

- **(A)** – Extend about 35 mm (0.11 ft), so that the cutout **(4)** is cleared.
- **(B)** – Screw a screw into the bore hole **(1)**. The locking pin **(2)** must retract to behind the telescopic section **(3)**. If necessary, give the locking pin **(2)** a slight knock to help this procedure.
- Unlock the other side of the telescopic section as well.



Risk of damage due to a mechanically released lock

Under no circumstances may you operate the telescoping cylinder as long as the lock is mechanically released. Screw all set screws out of the bore holes immediately after finishing the repair work.

This prevents damage to the telescoping cylinder and the locking system.

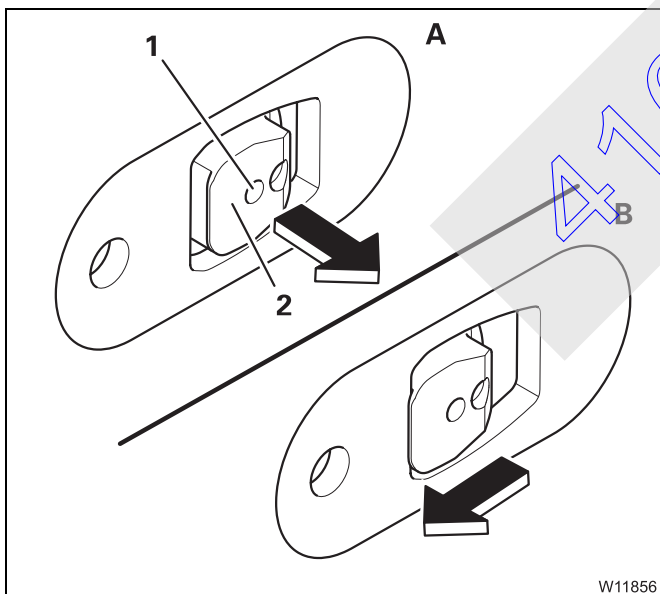

Locking the telescopic section

- **(A)** – Retract until the locking pin **(2)** is in the middle of the opening.
- Remove the screw from the bore hole **(1)** until the locking pin is extended completely.
- Take the set screw out of the bore hole.
- **(B)** – Retract further until the telescopic section is set down.



15.5.2

Telescoping emergency program

In the event of a malfunction in the telescoping mechanism you can retract the main boom with the *Telescoping* emergency program.

The emergency program is not intended for crane operation and is therefore restricted to a certain amount of time.

Starting the emergency program

Only start the emergency program when the  symbol is displayed;
 *Telescoping mechanism error messages*, p. 15 - 18.

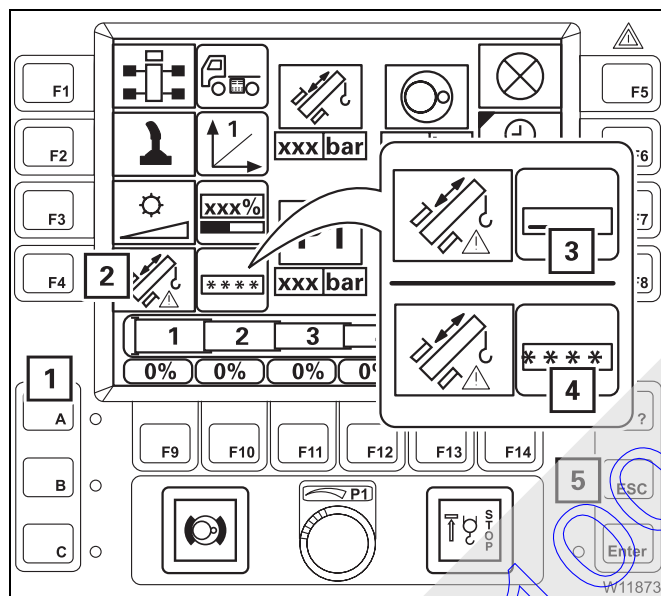

- Press the right-hand dead man's switch.
- Additionally press the button (2) once – symbol (3) appears.
- Press the buttons (1) in the order:



The symbols (4) confirm the entry.

If your input was incorrect, all the symbols (4) go out and you need to repeat the input.

You can cancel the entry at any time using button (5).

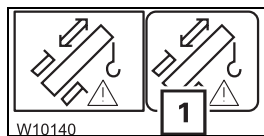

After correct input, the symbol (1) is displayed – the emergency program *Telescoping* starts.

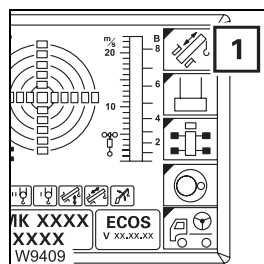

- If necessary, open the main menu  and press the button (1) once. The *Telescoping* submenu opens.



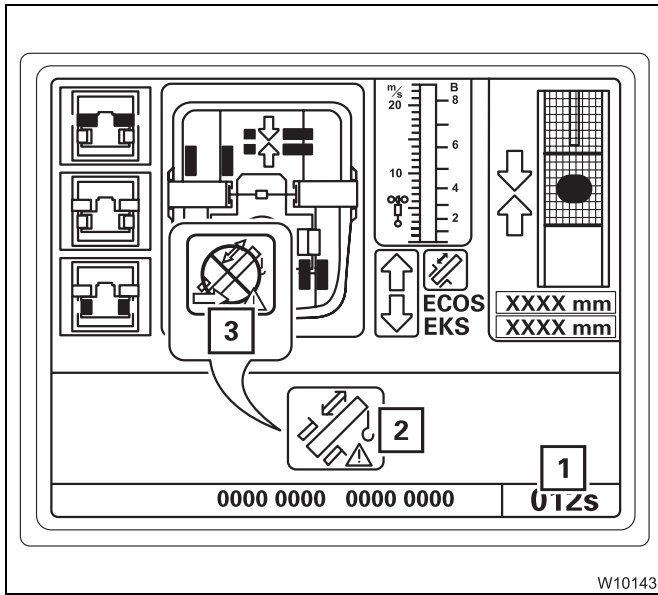

The emergency program is active if

- the symbol (2) is displayed and
- the display (1) is shown – a time span of about 360 seconds elapses.

The telescoping mechanism can be operated with the emergency program within this time.

After this time has elapsed, the symbol (3) appears, and you need to restart the emergency program.

Determining the type of error

- Check which emergency program procedure is suitable for the current error:



Risk of damage to the telescoping mechanism

Ensure you always have an overview of the current status of the telescoping mechanism before you initiate locking or unlocking. In emergency mode, there is no monitoring of prerequisites – the function is performed **immediately** after pressing the button.

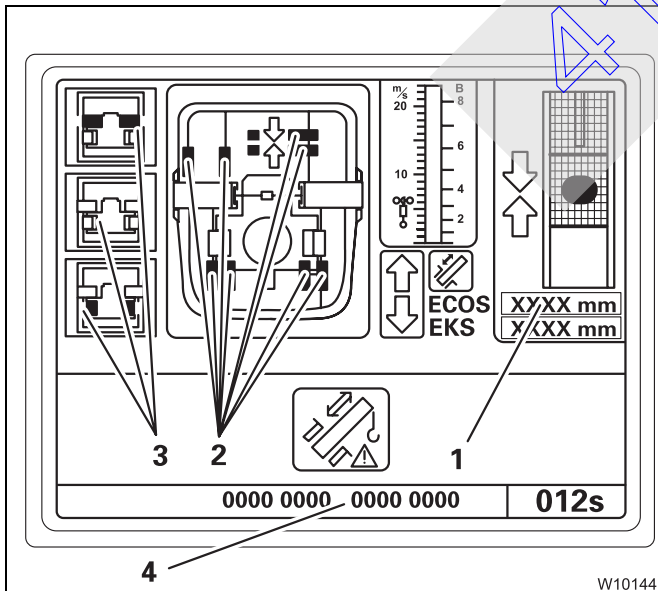

- If the display (1) shows no value, there is an error on the length indicator.
- If a symbol (2) is violet, there is an error on the proximity switch.

The buttons next to the symbols (3) are active. After pressing the button, locking or unlocking is performed **immediately**.

- Note down the error code (4) first if you intend to contact **CraneCARE** before carrying out the emergency program.



Risk of damage to the main boom

Never telescope the main boom if there is an error on the length indicator and on the proximity switch at the same time.

It would then not be possible for you to monitor operations, and components in the main boom could be damaged, or a situation could arise in which the main boom can no longer be extended or retracted.



In the *Telescoping* emergency program, all functions for retracting the main boom remain enabled as long as there are no other errors (hydraulic or mechanical).

The speed is restricted to approximately 30% of the maximum speed.

- If there is an error on the proximity switch; p. 15 - 45.
- If there is an error on the length indicator; next section.

If there is an error on the length indicator

First register the current status of the telescoping mechanism.

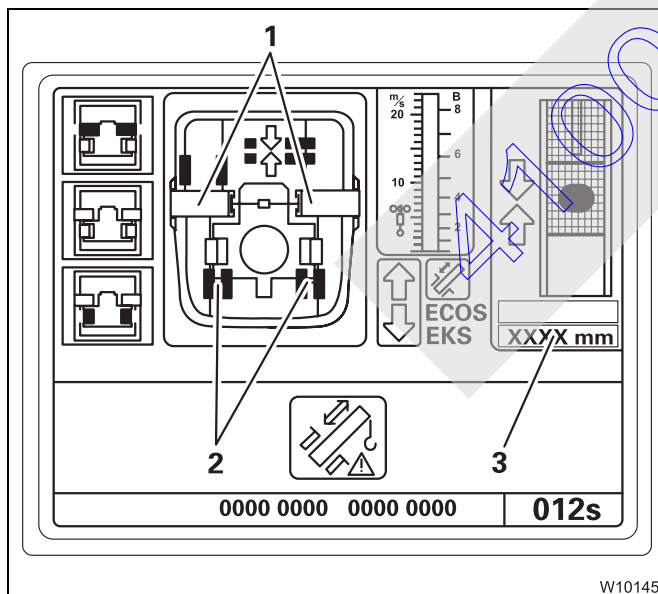

- Check the positions of the locking pins as usual, i.e. on the displays (1) and (2).
- Check whether the display (3) shows the SLI measured value for the extended length of the telescoping cylinder.
- Check the telescoping on the SLI.



Inspections prior to telescoping

- Before telescoping, check that the following conditions are met:



Risk of accidents from sudden retraction of a telescopic section

Press the  button for unlocking the telescopic section **no more than twice**. If this does not start the unlocking procedure, contact **CraneCARE**.

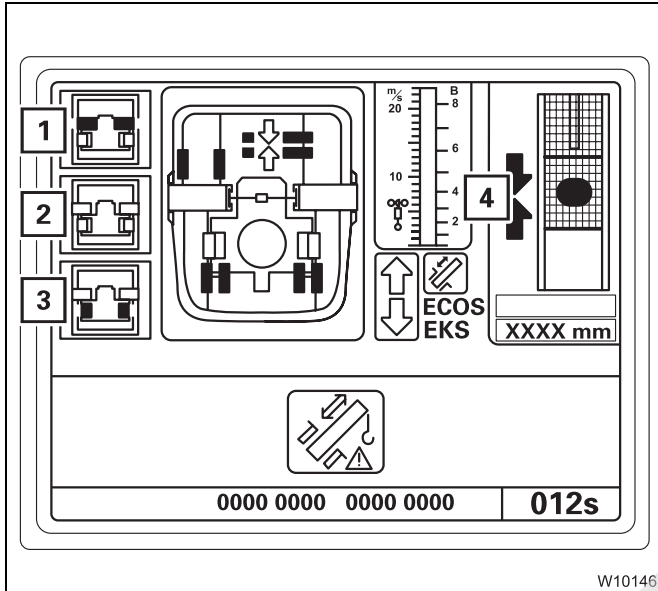

- The telescopic cylinder is locked, symbol (3) is **grey**.
- The telescopic section is unlocked (**press no more than twice**), symbol (1) is **yellow**.
- Locking is not selected, symbol (2) is **grey**.
- The telescoping cylinder is at the locking point, the arrows (4) are **green**.

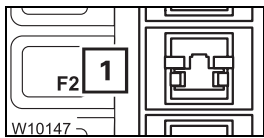

Retracting and locking a telescopic section

During telescoping you must **not** select Lock. **Under no circumstances** press the button (1)



Risk of damage to the main boom

If you select Lock during telescoping, the locking pins on the telescopic section are slid out immediately and they can damage or tear the electrical or hydraulic components in the main boom.

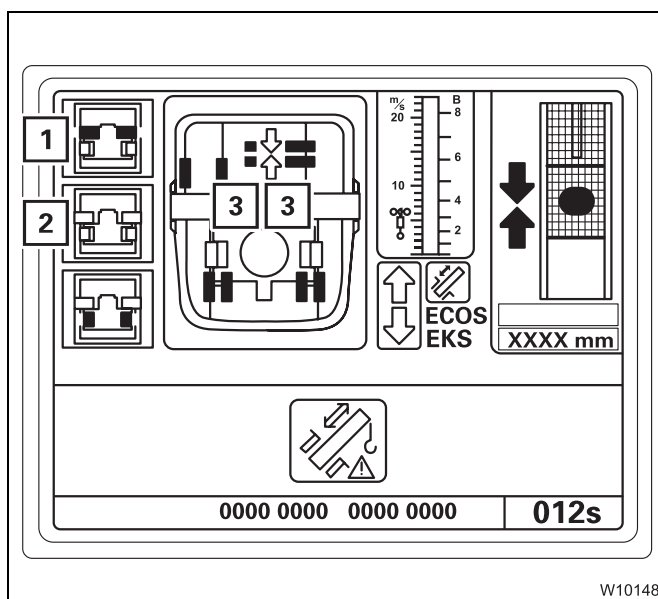

- Retract the telescopic section slowly and as far as possible.
- Press button (f) once.
- Extend to about 35 mm (0.11 ft).

The telescopic section is locked. In *Locked* position:

- the locking pins (3) are **green**,
- the symbol (1) is **grey**,
- the symbol (2) is **yellow**.
- Set down the telescopic section and retract it as far as it will go.

Unlocking the telescopic cylinder

If the telescopic section is locked, you can now unlock the telescopic cylinder.



Risk of accidents from sudden retraction of a telescopic section

Press the  button for unlocking the telescopic cylinder **no more than twice**. If this does not start the unlocking procedure, contact **CraneCARE**.

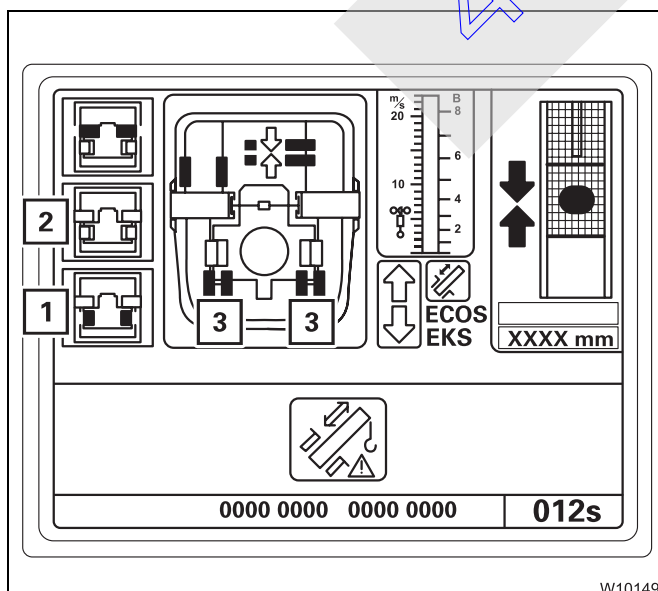

- Press the button (1) once (**at the most twice**).

The telescopic cylinder is unlocked. In *Unlocked* position:

- the locking pins (3) are **red**
- the symbol (1) is **yellow**,
- the symbol (2) is **grey**.

You can now move the telescopic cylinder into the next telescopic section.



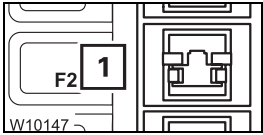

Extending and locking the telescoping cylinder

You must **not** select Lock while the telescoping cylinder is retracting or extending. **Under no circumstances** press the button (1)



Risk of damage to the main boom

If you select Lock while the telescoping cylinder is moving, the locking pins on the telescopic section are slid out immediately and they can damage or tear the electrical or hydraulic components in the main boom.

- Slowly move the telescoping cylinder into the next extended telescopic section.

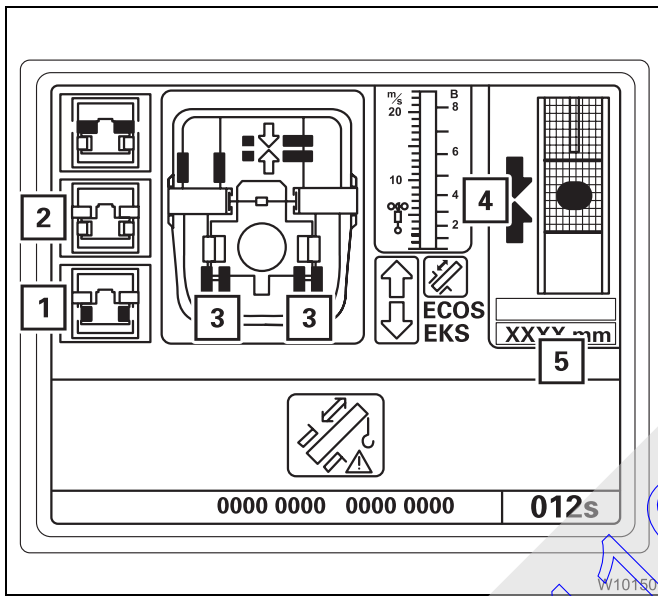

At the locking point:

- the arrows (4) are green,
- the display (5) shows the length for the current locking point; p. 15 - 47.

- Press button (1) once.

The telescoping cylinder is locked. In *Locked* position:

- the locking pins (3) are **green**,
- the symbol (1) is **grey**,
- the symbol (2) is **yellow**.

- You can now retract this telescopic section; p. 15 - 42.

If there is an error on a proximity switch

Faulty proximity switches are shown in violet.
The displays (A), (B) and (C) only show the current positions when **all** the corresponding proximity switches are free of error.

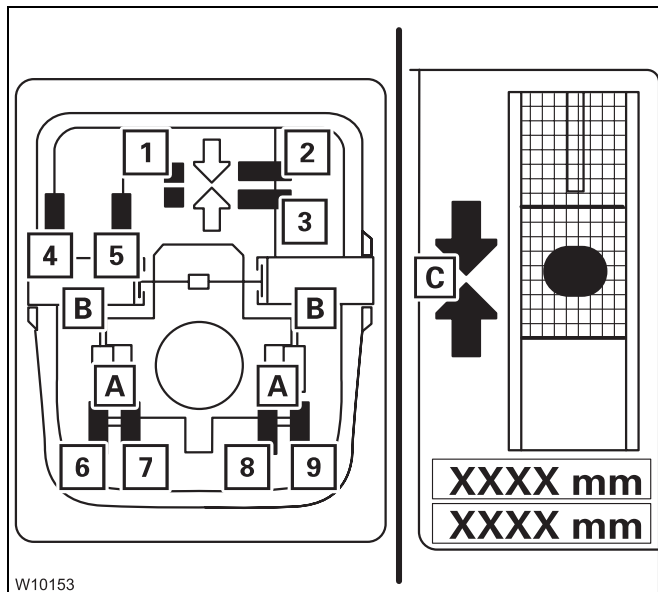

Several proximity switches are related to the displays (A), (B) and (C).

For **A**: proximity switch (6) to (9)

For **B**: proximity switch (4) and (5)

For **C**: proximity switch (1) to (3)

When a proximity switch is faulty (violet), then

- the corresponding locking pins on the displays (A) and (B) are always yellow.
- the corresponding arrows are not shown on the display (C).

When an error occurs, you can determine the current position more precisely based on the other, fault-free proximity switches. The proximity switches show the following positions:

– **Display (C) – telescoping cylinder at the locking point**

- 1 At the locking point
- 2 Behind the locking point
- 3 In front of the locking point

– **Display (B) – telescopic section locked**

- 4 Locked
- 5 Unlocked

– **Display (A) – telescoping cylinder locked**

- 6 Locked left
- 7 Unlocked left
- 8 Unlocked right
- 9 Locked right

For fault-free proximity switches, the following applies:

- **Green:** position reached
- **Red:** position not reached



Required inspection

When the *locked* position can no longer be shown, always conduct the following checks before unlocking:

- Carefully retract and extend the telescoping cylinder or telescopic section. In the *locked* position, the length shown on the displays (1) should only vary slightly, i.e. by the play of the locking pins.

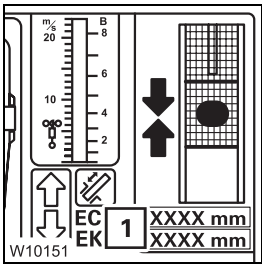

Retracting

The steps for retracting are the same when an error occurs on the proximity switch as for an error on the length indicator.

– When the display (C) fails

- Calculate the telescoping cylinder length for the locking point;
 ▶ *Locking points for the telescoping cylinder*, p. 15 - 47, ▶ *Locking points for the telescopic sections*, p. 15 - 48.
- Move the telescoping cylinder to the required length – display (1).

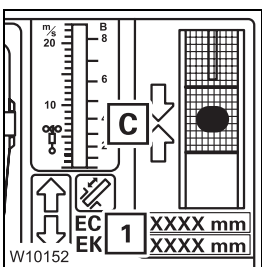

Risk of damage if the length specifications are not observed

Extend the telescoping cylinder (without telescopic section) only to the specified length.

This prevents the piston rod from becoming damaged if the telescoping cylinder slides out of the telescopic section.

Terminating the emergency program

The emergency program is terminated:

- if the displayed time has expired or
- when the ignition is turned off.



The current telescoping status does not correspond to the telescoping status last saved by ECOS if the *Telescoping* emergency program was open. You must enter the current telescoping after terminating the emergency program; ▶ *Entering the current telescoping*, p. 15 - 49.

Tables for approaching the locking points

The extent to which the telescoping cylinder has to be extended in order to reach a locking point depends on whether you:

- want to lock the telescoping cylinder or
- lock a telescopic section.

Locking points for the telescoping cylinder

The following table shows the extended length for locking the telescoping cylinder.

Table for locking the telescoping cylinder		
Telescopic section	Locking point at fixed length	Extended length of the telescoping cylinder
	in %	in mm (in ft)
Telescopic section I	0	5 (0,02)
	50	4 215 (13,83)
	100	8 425 (27,64)
Telescopic section II	0	325 (1,07)
	50	4 498 (14,76)
	100	8 670 (28,45)
Telescopic section III	0	615 (2,02)
	50	4 745 (15,57)
	100	8 875 (29,12)
Telescopic section IV	0	900 (3,01)
	50	4 888 (16,04)
	100	8 875 (29,12)
Telescopic section V	0	1 175 (3,85)
	50	5 025 (16,49)
	100	8 875 (29,12)



Locking points for the telescopic sections

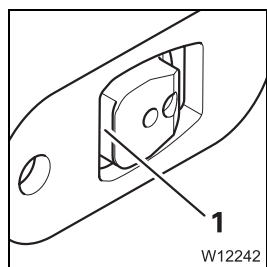

The telescopic section must not be set down for locking or unlocking it.

The cutout (1) must be clear. That is why you have to extend the telescoping cylinder 35 mm (0.11 ft) further than with a return run.

The following table shows the extended length for locking and unlocking the telescopic sections.

Table for locking / unlocking the telescopic sections		
Telescopic section	Locking point at fixed length	Extended length of the telescoping cylinder
	in %	in mm (in ft)
Telescopic section I	0	40 (0,13)
	50	4 250 (13,94)
	100	8 460 (27,76)
Telescopic section II	0	360 (1,18)
	50	4 533 (14,87)
	100	8 705 (28,56)
Telescopic section III	0	650 (2,13)
	50	4 780 (15,68)
	100	8 910 (29,12)
Telescopic section IV	0	935 (3,07)
	50	4 923 (16,15)
	100	8 910 (29,23)
Telescopic section V	0	1 210(3,97)
	50	5 060 (16,60)
	100	8 910 (29,23)

15.5.3

Entering the current telescoping

ECOS no longer displays the current telescoping

- if you telescoped in emergency mode or
- if the power supply was interrupted in the course of saving data.

In these cases you must enter the current telescoping, e.g. the values from the SLI display.

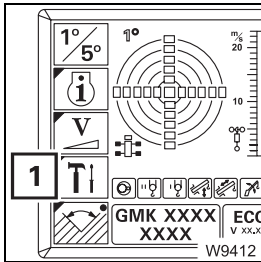

- If necessary, open the main menu **Esc** and press the button **(1)** once.

The *Settings* submenu opens.

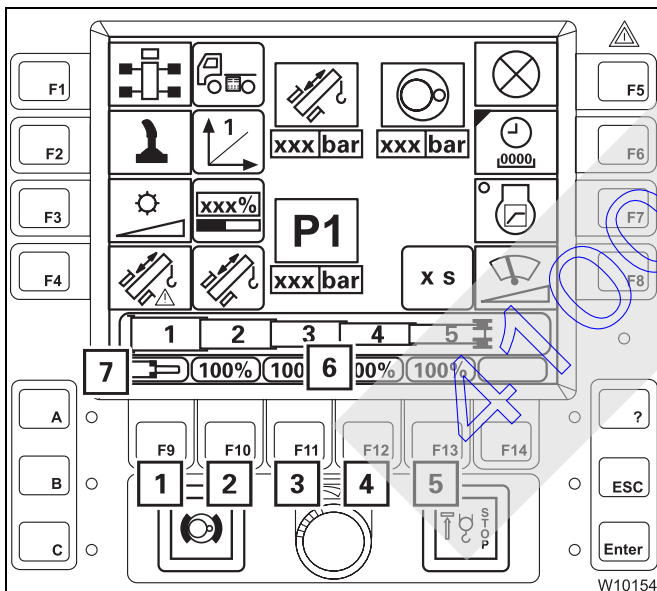

To enter set values

The display **(6)** shows the values for telescopic sections I to V.

- Press one of the buttons **(1)** to **(5)** – the values in the display **(6)** turn yellow.

Each time you press a button, the corresponding value in the display **(6)** switches continuously between the fixed lengths and the symbol **(7)** for *Unlocked*.

- Enter the desired set values for all telescopic sections, e.g. unlocked, 100%, 100%, 100%, 100%.

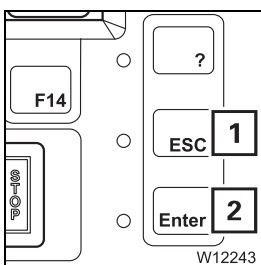

You can cancel the entry at any time using button **(1)**.

- Confirm the entered required values – press button **(2)** once.

You must now accept the values.



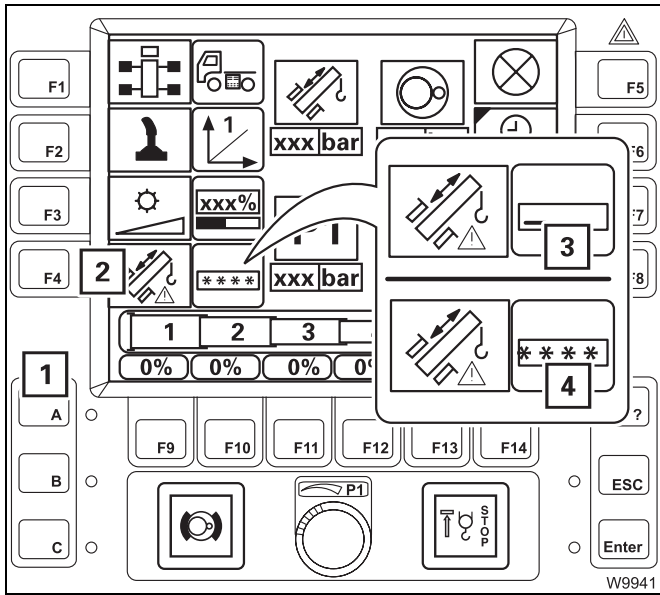

- Press the left-hand dead man's switch.
- Additionally press the button (2) once – symbol (3) appears.
- Press the buttons (1) in the order:



The symbols (4) confirm the entry.

If your input was incorrect, all the symbols (4) go out and you need to repeat the input.

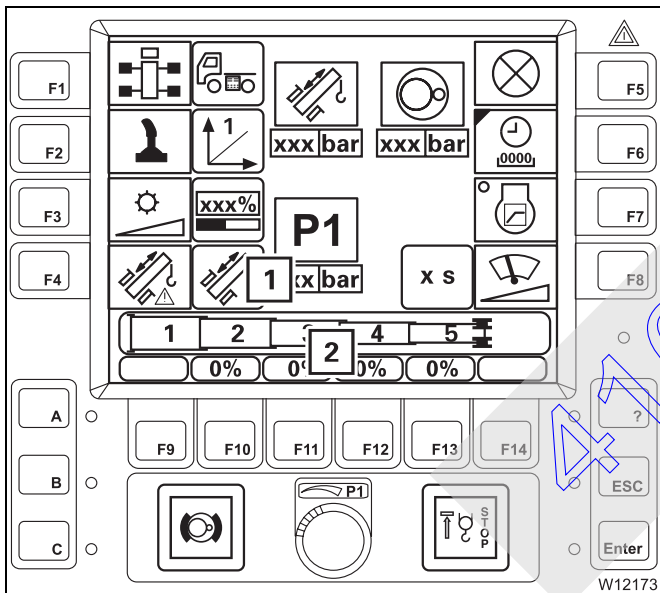

If the set values entered are **not permissible**, the values on the display (2) turn **red**.

If the set values entered are **permissible**, the values on the display (2) turn **green**.

The display (1) shows the symbol for the current status.



Risk of damage due to incorrect input

Before working with the crane, check whether ECOS now indicates the correct telescoping and correct the input, if necessary. Entering incorrect values causes malfunctions and may cause damage to the telescoping mechanism.

15.5.4

Emergency operation with the hand-held control

If the power units no longer respond to the operating elements in the crane cab, you can operate the power units with the hand-held control.

Operating them with the hand-held control is intended for emergencies only and for bringing the truck crane into a safe condition or supporting it.



Danger of overturning due to deactivated monitoring function

The **SLI is switched off** and the crane operations are not monitored when operating with the hand-held control. If you move into a critical range, the truck crane will overturn.

Preparations

You have to connect up the hand-held control and start the engine.

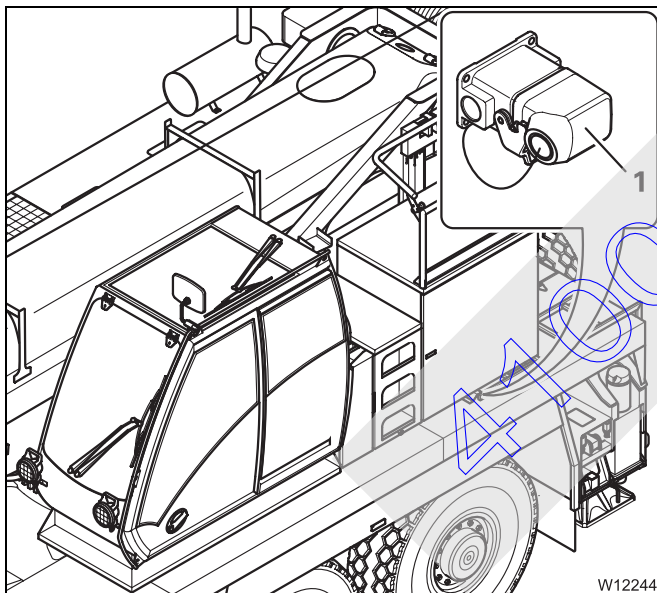

To connect the hand-held control

- Connect the hand-held control to the connector (1).

All power units can be operated from this connection.

Information on connecting; ►► p. 13 - 20.

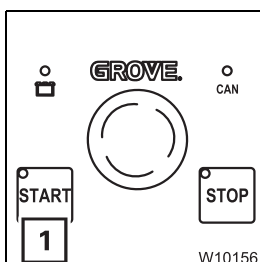

To start the engine

- Press the button (1) once – the engine starts; ►► p. 11 - 17.



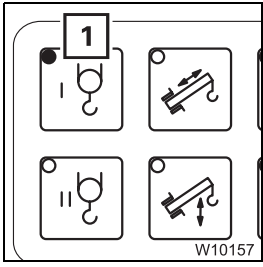

To pre-select a power unit

- Press the button for the desired power unit once, e.g. the button (1) for the main hoist.

When the function is enabled, the lamp in the button lights up.



With the telescoping mechanism, teleautomation with the target 0 / 0 / 0 / 0 / 0 is always selected at the same time – fully retract. The extension function is disabled in emergency mode.

Operating a power unit

All the safety instructions contained in the sections on the individual power units also apply to operation with the hand-held control.



Danger of overturning when driving into the shutdown ranges

Avoid lowering. If you cannot avoid lowering, try to set down the load beforehand, and ensure that the maximum permissible working radius for the rigging mode as specified in the *Lifting capacity table* is not exceeded. Before slewing, always check whether this is permissible in the current rigging mode;  *Slewing with rigged counterweight*, p. 13 - 82.



Risk of accidents when operating the slewing gear

Sit down in the crane cab to operate the slewing gear. This prevents you from being pushed off the carrier or being crushed by the carrier as a result of slewing.



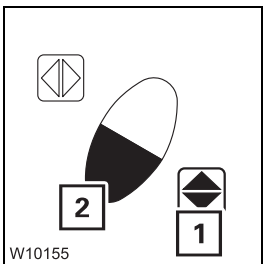

Lay the connecting cable of the hand-held control so that it will not catch on anything.



- Press the required function buttons one after the other, e.g. for *Lift main hoist*, press button (1) first, and then also button (2).

The further you press button (2), the quicker the movement is. The maximum speed is limited to about 50% for all power units.

The following table shows all the button combinations. Actuated buttons are marked black.

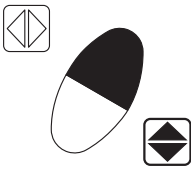
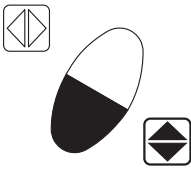
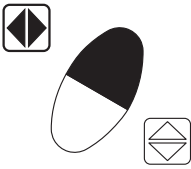
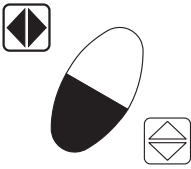
Button combination	Pre-selected power unit				
	Telescoping mechanism 	Derricking gear 	Slewing gear 	Hoists 	Lattice extension 
 W3851	none ¹⁾	lower	none	lower	lower
 W3850	retract	raise	none	lift	raise
 W3849	none	none	slew to right	none	none
 W3848	none	none	slew to the left	none	none

¹⁾ If the telescoping cylinder is extended, it will extend.



Stopping movements

The movement continues until you let go of the button or the end position is reached.

Stopping movements in emergencies

You can stop operations with the Emergency-stop switch if they do not stop by letting go of the *function buttons*;  p. 11 - 20.

Turning off the engine

You can only turn off the engine with the hand-held control. In this case it is not possible to turn off the engine via the ignition lock.

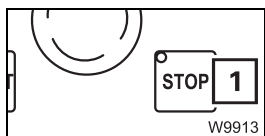

- Stop all crane movements.
- Press the button (1) – the engine shuts down.

41005067

15.5.5

Switching on emergency operation in coolant circuit

For cooling purposes, the fan wheel of the engine is switched on and off automatically. When this automatic system fails, you can switch on emergency operation so that the fan wheel always runs when the engine is switched on.

- Switch off the engine and secure it against being started by unauthorized persons – put the hand-held control into the crane cab and lock the door.



Risk of accidents due a turning fan wheel

Always switch off the engine and secure against unauthorized use before switching on emergency operation.

This prevents the fan wheel from starting to turn suddenly, and injuring you.



Risk of burning yourself when the engine is hot

During operation, the engine and the add-on parts heat up to a great extent. Wear appropriate protective gloves and be careful not to touch hot parts.

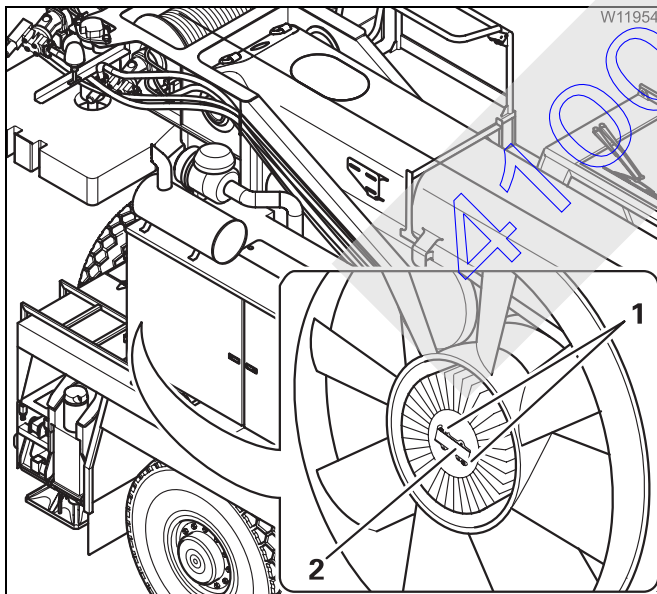

Emergency operation is switched on at the fan wheel's hub.

- Undo the screws (1).
- Turn the metal plate (2) and remove it.
- Press in the pin under the metal plate.
- Emergency operation is activated and the fan wheel will run continuously as long as the engine has been switched on.

When the fan wheel is blocked, the engine can be operated for a maximum of 20 hours.

Blank page

41005067

15.6

Hydraulic emergency operation

With this additional equipment the truck crane is supplied with a hydraulic emergency bleed valve in accordance with guidelines BGR 159 (4.2.8). This allows small loads to be transported in case of emergency, e.g. in the event of an engine failure.



Risk of accidents due to improper use

Only operate in hydraulic emergency operation to transport small loads in emergencies and have the malfunction rectified as soon as possible. Crane operation in hydraulic emergency operation is prohibited since it is not monitored by the SLI.

15.6.1

Operating principle

The hydraulic emergency operation BGR 159 enables

- the **emergency operation** of the main hoist, derricking gear, and slewing gear as well as
- the **emergency supply** of another truck crane that also has a hydraulic emergency operation BGR 159.

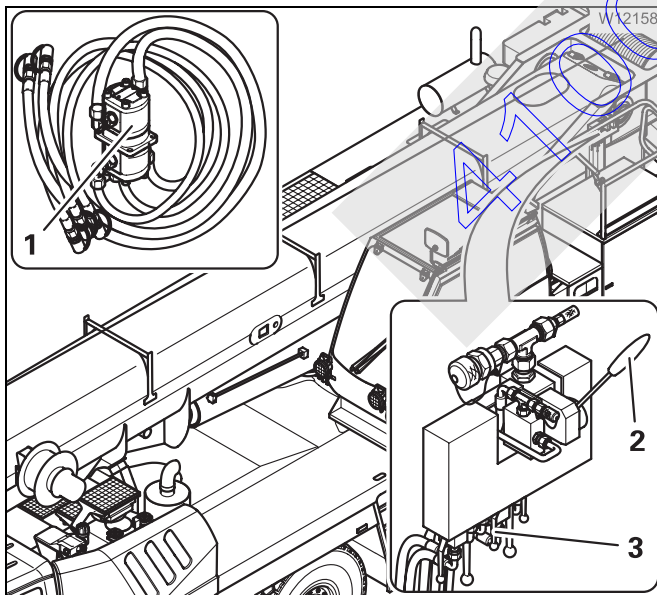

Emergency operation

A transformer (1) serves as a power source for the crane's hydraulic system. The transformer is powered by the carrier's hydraulic system or by the emergency supply of another truck crane.

The hydraulic circuits are triggered with the valves (3).

The control lever (2) regulates the direction of movement and the speed.



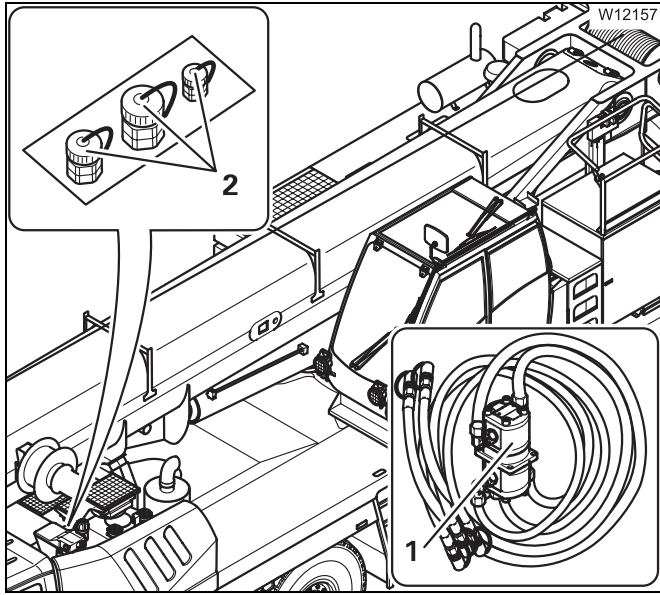

Emergency supply

In the event of emergency supply, the connections (1) feed a transformer (2) which is connected to the hydraulic system of another crane; **Emergency supply of another crane**, p. 15 - 67.

15.6.2 Connecting/disconnecting hoses

- Turn off the engines for driving and crane operations.



Risk of damage to the hoses

Lay the hoses in such a manner that they can be moved freely in order to prevent them from being crushed or torn or getting caught during the subsequent crane movements.

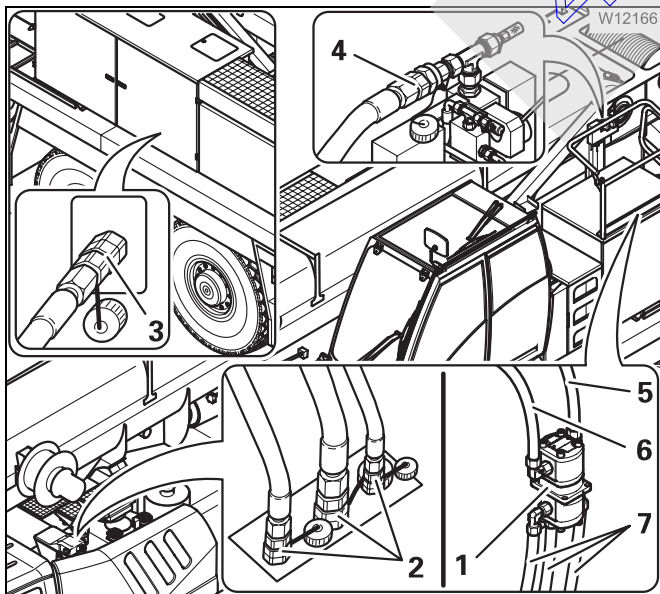

Establishing connections

- Attach the transformer (1) to the superstructure.
- Connect the thicker hose (6) to the connection (3).
- Connect the thinner hose (5) to the connection (4).
- Connect the hoses (7) to the connections (2).

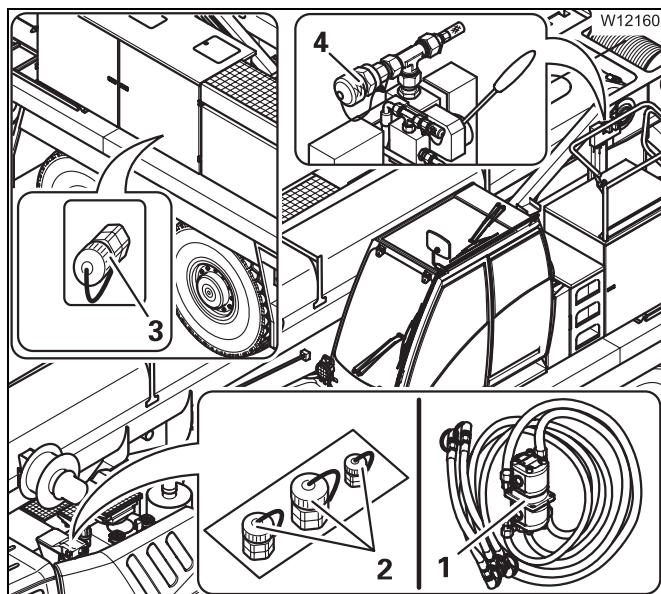

Disconnecting

- Remove the hoses from the connections (2), (3), and (4).
- Close the hoses and the connections with the caps.
- Remove the transformer (1).

15.6.3

Activating/deactivating emergency operation

The emergency operation (for emergency supply of another crane) is activated and deactivated in the driver's cab.

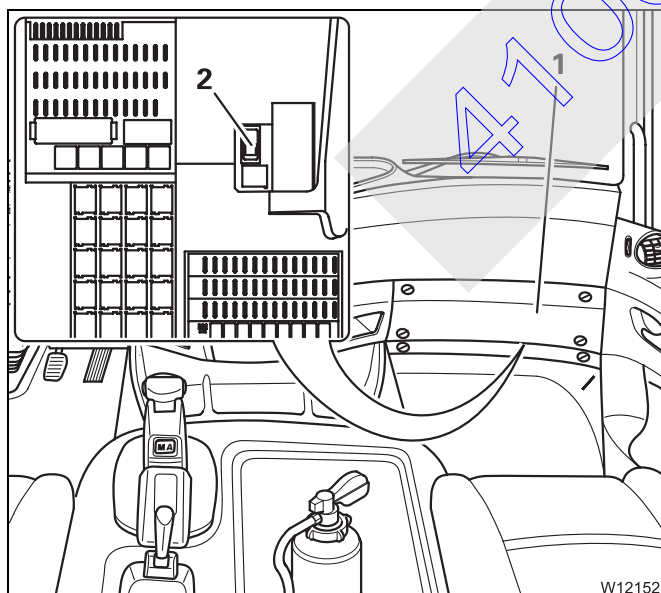

- Remove the cover (1).
- Start the engine for driving.

Switching on

- Press switch (2) down.

Switching off

- Press switch (2) up.

15.6.4

Establishing the required hydraulic circuits

To establish a hydraulic circuit, switch over the required valves and possibly also perform additional switching operations for lifting/lowering or slewing.

Switching over valves

The valves **1** to **5** are numbered.

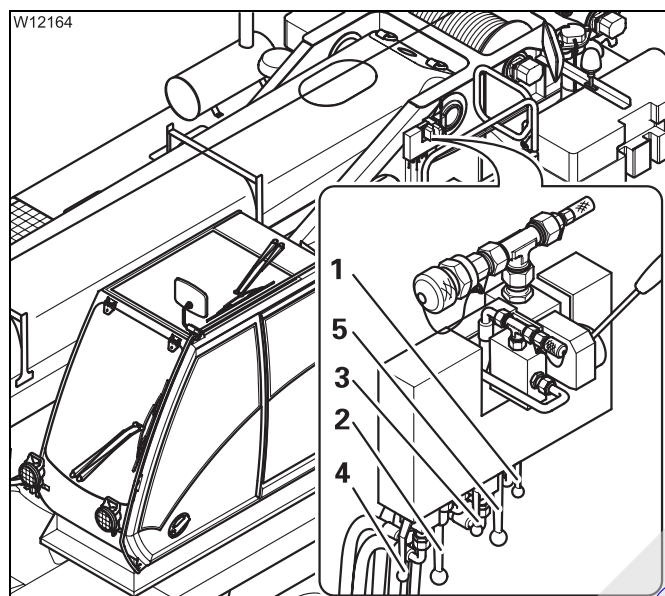

For crane operation

- Switch the valves **1** to **5** down.



Danger due to mutual interference of the power units

For crane operation, always switch **all** the valves **1** to **5** down. This prevents the power units from suddenly starting to move.

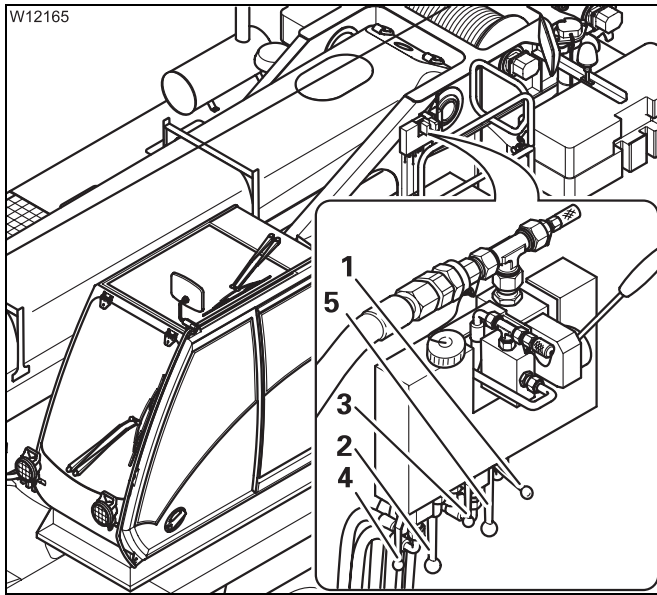

For emergency operation

- Switch the valves **1 to 5** to the positions for the required crane movement - as shown in the following table.

For the main hoist, for example, switch the valve **1 outward**. Valves 2, 3, 4, and 5 must point down.



Danger due to mutual interference of the power units

For **one crane movement**, always switch valves outward. This prevents wrong crane movements from being performed and several movements from being performed unintentionally at the same time.

Emergency operation for crane movements	Valves outward	Valves downward	Additional switching operations
Lifting	1	2, 3, 4, 5	Valve Y1105 on continuous operation; p. 15 - 62
Lowering (Main hoist)	1	2, 3, 4, 5	Valve Y1104 on continuous operation; p. 15 - 62
Raising	3	1, 2, 4, 5	none
Lowering (Derricking gear)	5	1, 2, 3, 4	none
Slewing	2, 4	1, 3, 5	Valve 6, 7, 8 closed; p. 15 - 63



**For lifting/
lowering**

After establishing hydraulic circuits, additionally switch one valve to continuous operation.

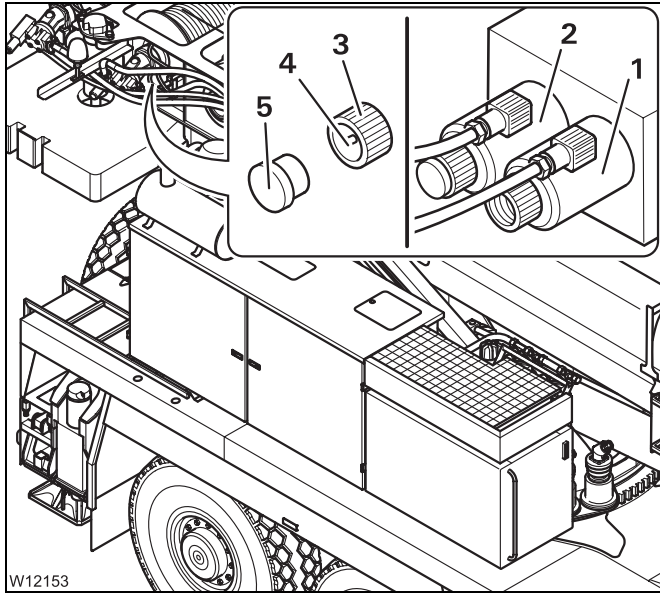

Switching on continuous operation

Always switch only **one** valve to continuous operation.

- 1 Valve Y1104 – Lowering **or**
- 2 Valve Y1105 – Lifting

- Screw off the cap (3), e.g. off valve (1).
- Remove the plug (5).
- Screw the cap and pin (4) onto the valve – continuous operation is switched on.

W12153



Danger due to falling loads

Switch off continuous operation immediately after the emergency operation.

Check whether the pins can be seen on both caps.

In this way, you can prevent loads from falling immediately after being lifted during subsequent crane operations.

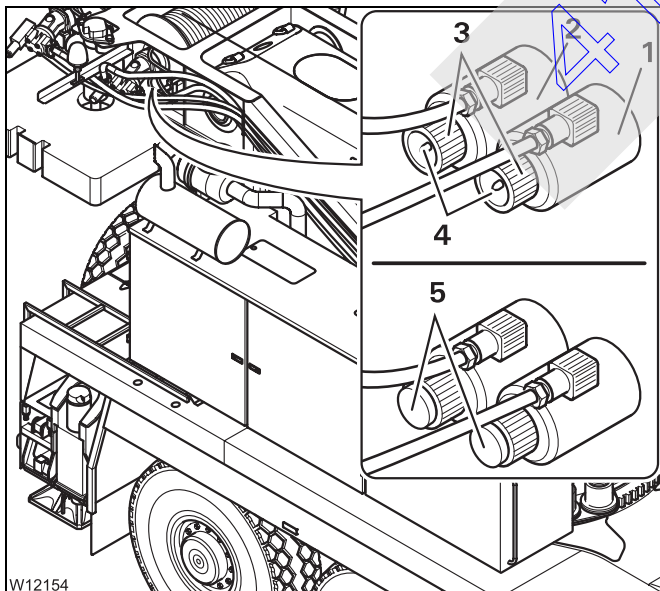

To switch off continuous operation

- Remove the cap (3) from the actuated valve (1), (2).
- Screw on the cap so that the pin (4) can be seen.
- Insert the plug (5).

W12154

For slewing

After establishing hydraulic circuits, close the additional valves for the slewing gear.

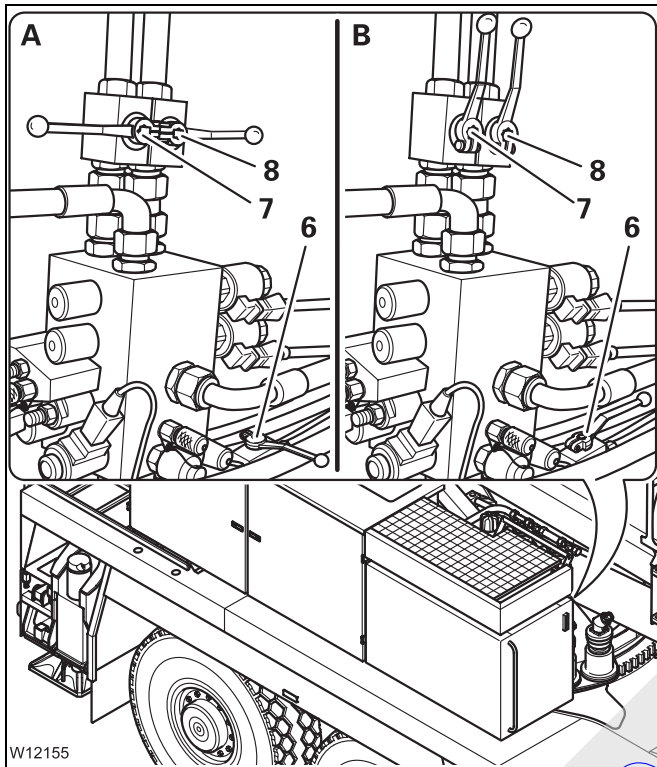

Always bring the valves on all slewing gears into the required position.

(A) – Emergency operation position

- Close the valves **6**, **7**, and **8** – lever at right angles to the line.

(B) – Crane operation position

- Open the valves **6**, **7**, and **8** – lever parallel to the line.

15.6.5

Carrying out emergency operation

If the required hydraulic circuit has been established, you can operate the corresponding crane movement.



You can control the speed of all power units with the control lever.

Slewing

It is not possible to control the slewing movements with the control lever for emergency operation with the same degree of sensitivity as with the control lever in the crane cab.



Risk of accidents during slewing

Do not stand on the carrier. This prevents you from being pushed off the carrier or being crushed by the carrier as a result of slewing.



Risk of damage to the hoses and transformer

Make sure the hoses do not get caught and torn off while performing slewing operations.

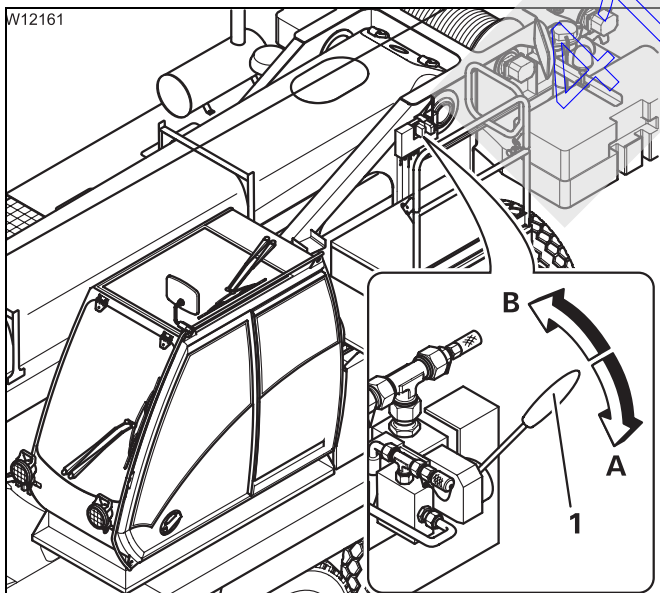

- Slowly move the control lever (1) in the required direction:

- A: Slewing to the right
- B: Slewing to the left

Derricking

- Determine the maximum permissible working radius for the current rigging mode according to the *Lifting capacity table*.



Danger of overturning if the working radius is too large when lowering the boom

In emergency operation, operations are not shut down by the SLI. This also applies if the SLI displays are still active after switching on the ignition. The truck crane will overturn if you exceed the maximum permissible working radius for the current rigging mode as specified in the *Lifting capacity table* when lowering the boom.

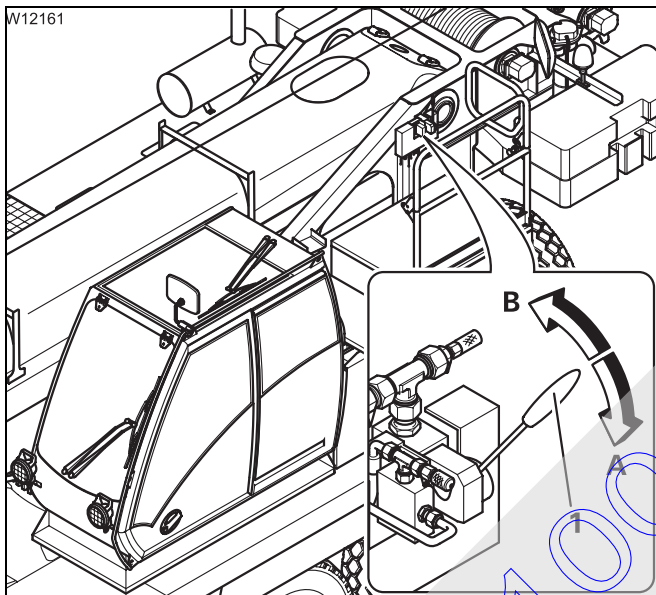

- Observe the maximum permissible working radius specified in the *Lifting capacity table* – if necessary, by measuring.
- Move the control lever (1) in the required direction:

A: Lowering
B: Raising

Lifting/lowering

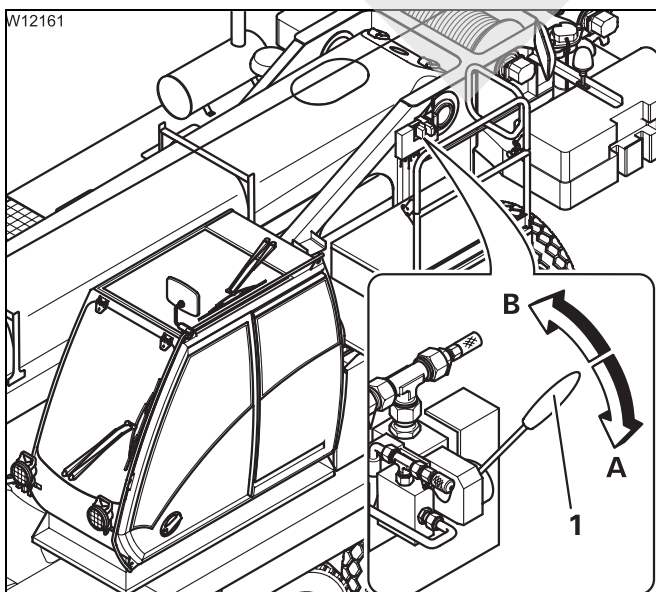

- Move the control lever (1) in the required direction:

A: Lowering
B: Lifting

15.6.6

After emergency operation

You must restore the truck crane to its original condition after finishing emergency operation.

Switching off emergency operation

- Switch off the engine.

Switching to crane operation

After every emergency operation

- Switch valves **1** to **5** to crane operation; ■■■▶ p. 15 - 60.

Additionally after lifting/lowering

- Switch off continuous operation on the valves Y1105 and Y1104; ■■■▶ p. 15 - 62.

Additionally after slewing

- Open valves **6**, **7**, and **8**; ■■■▶ p. 15 - 63.

Disconnecting the hoses

- Disconnect the hoses; ■■■▶ p. 15 - 59.
- Close all the connections and hoses with the caps.
- Remove the transformer.

41005067

15.6.7

Emergency supply of another crane

Before emergency supply

The hoses are assigned according to the various diameters.

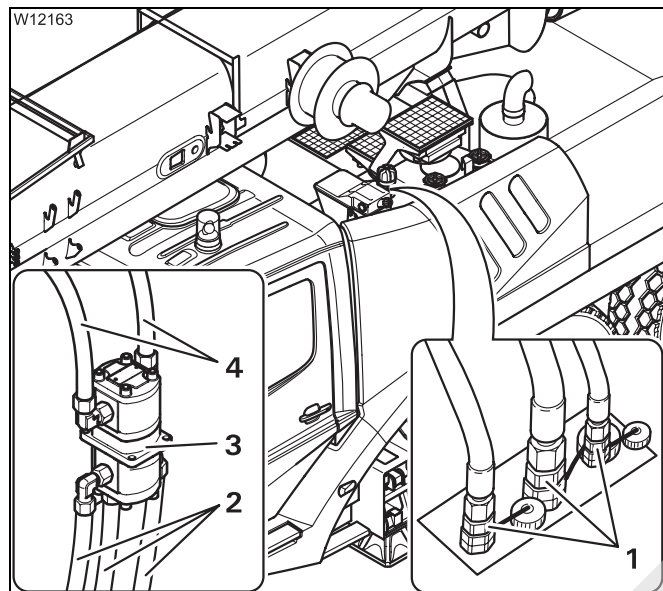

On the crane to be supplied

- Attach the transformer (3).
- Attach the hoses (4); *Operating manual of the other crane.*

On the GMK 4100

- Turn off the engine for driving.
- Connect the hoses (2) to the connections (1).
- Switch on hydraulic emergency operation; p. 15 - 59.

After emergency supply

- Switch off hydraulic emergency operation; p. 15 - 59.

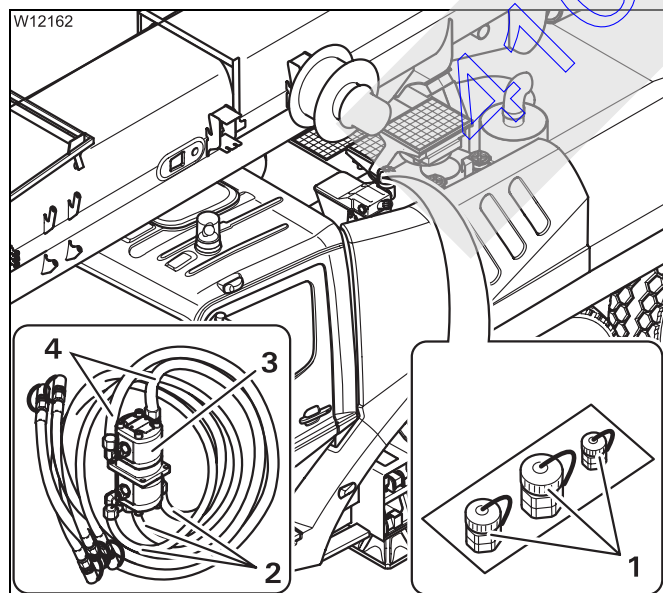

On the GMK 4100

- Remove the hoses (2) from the connections (1).

On the crane that was supplied

- Remove the hoses (4).
- Close all the connections and hoses with the caps.
- Remove the transformer (3).

Blank page

41005067

16 Technical information for the superstructure

16.1	Technical data	16 -	1
16.1.1	Maximum lifting capacity (DIN / ISO / EN)	16 -	1
16.1.2	Maximum lifting capacity (ANSI B 30.5)	16 -	1
16.1.3	Dimensions and weights of the truck crane, axle loads	16 -	2
16.1.4	Dimensions and weights of removable parts	16 -	2
16.1.5	Superstructure	16 -	4



41005067

16

Technical information for the superstructure

16.1

Technical data

GROVE truck crane GMK 4100

Permissible temperature range: -25 °C to +40 °C (-13 °F to +104 °F)

Crane designation: Truck crane in accordance with
DIN 15 001, part 1

Crane application: Service crane in accordance with
DIN 15 001, part 2

Crane classification: Hoist class H1 in accordance with
DIN 15 018, part 1
Crane class A1 in accordance with
ISO 4301, part 2

The crane is designed in accordance with crane class A1 (as defined in ISO standard 4301 - 2). This relates to the engineering design (specification of quality) and is not a guarantee in the sense of § 443 BGB (German federal law).

16.1.1

Maximum lifting capacity (DIN / ISO / EN)

Max. load bearing capacity: 85.0 t (185,000 lbs)

Max. load moment

– in working position 0° to the rear: 301.5 tm (33.5 t x 9 m)

– within the 360° slewing range: 290.0 tm (29.0 t x 10 m)

16.1.2

Maximum lifting capacity (ANSI B 30.5)

Max. load bearing capacity: 85.0 t (185 000 lbs)

Max. load moment

– in working position 0° to the rear: 315.0 tm (35.0 t x 9 m)

– within the 360° slewing range: 302.5 tm (27.5 t x 11 m)

16.1.3

Dimensions and weights of the truck crane, axle loads

- Dimensions; ■■■► p. 8 - 3.
- Weights and axle loads in condition for driving on-road; ■■■► p. 8 - 3.
- Rigging mode and axle loads when driving with rigged crane; ■■■► p. 6 - 1.

16.1.4

Dimensions and weights of removable parts

This section contains the dimensions and weights of the parts which can be removed for on-road driving; ■■■► *Driving modes*, p. 6 - 1.

Hook blocks and hook tackle

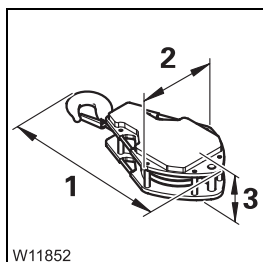

Description	(1) x (2) x (3) in m (ft)	Weight in kg (lbs)
Hook block 9 sheaves	2.00 x 0.55 x 0.85 (6.55 x 1.80 x 2.80)	1,500 (3,305)
Hook block 7 sheaves	1.75 x 0.55 x 0.70 (5.75 x 1.80 x 2.30)	1,000 (2,205)
Hook block 5 sheaves ¹⁾	1.65 x 0.55 x 0.50 (5.40 x 1.80 x 1.65)	750 (1,655)
Hook block 3 sheaves ¹⁾	1.50 x 0.55 x 0.40 (4.90 x 1.80 x 1.30)	550 (1,215)
Hook block 1 sheave	1.40 x 0.55 x 0.25 (4.60 x 1.80 x 0.85)	300 (660)
Hook tackle	0.90 x 0.35 x 0.35 (2.95 x 1.15 x 1.15)	200 (440)

¹⁾ Single or double hook

Lifting capacity of the hook blocks; ■■■► p. 13 - 96.

Counterweight parts

Description	Length x width x height in m (ft)	Weight in kg ¹⁾ (lbs)
2.2 t base plate	2.75 x 1.00 x 1.00 (9.0 x 3.3 x 3.3)	2,200 (4,850)
2.2 t section	2.75 x 1.65 x 0.20 (9.0 x 5.4 x 0.7)	2,200 (4,850)
4.4 t section	2.75 x 1.65 x 0.25 (9.0 x 5.4 x 0.8)	4,400 (9,700)
3.3 t section (version C)	1.60 x 1.00 x 0.50 (5.3 x 3.3 x 1.7)	3,300 (7,280)
2.2 t section (version C)	1.30 x 0.65 x 0.45 (4.3 x 2.2 x 1.5)	2,200 (4,850)
2.2 t section (version C, can be mounted on the turntable)	2.75 x 1.65 x 0.15 (9.0 x 5.4 x 0.5)	2,200 (4,850)

¹⁾ There may be deviations of up to $\pm 3\%$ due to the manufacturing procedure.

The stability of the crane rigged with the delivered counterweight parts has been tested.

Counterweight versions

▣▣▣▣ *Assembling counterweight versions, p. 13 - 61.*

16.1.5

Superstructure

Engine

Mercedes-Benz:	OM 904 LA
Power:	110 kW (150 HP) at 2200 min ⁻¹ (EC 80 / 1269 - 89 / 491 EEC, fan detached)
Engine emissions:	EUROMOT \ EPA \ CARB (off road)
Fuel tank ¹⁾ :	On the carrier – for both engines approx. 515 l (136 gal)

¹⁾ For additional equipment – on the superstructure, approx. 230 l (61 gal)

Hoists

Drum diameter:	337 mm (13.3 in) (rope centre to rope centre)
Rope diameter:	17 mm (0.67 in)
Rope length:	255 m (837 ft)
Max. rope pull:	56 kN / line (12,590 lbf)
Power unit group:	M 3 (in accordance with ISO 4301 - 2)
Load spectrum:	L 1
Factor of the load spectrum	$k_m = 0.125$
Theoretical service life:	$D = 3,200$ h

Slewing gear

Power unit group	M2 (in accordance with ISO 4301 - 2)
------------------	--------------------------------------

Derricking gear

Adjusting angle (main boom):	-3° to + 83° from horizontal position
Power unit group	M2 (in accordance with ISO 4301 - 2)

Main boom

Main boom lengths:	11.3 m to 52 m (37 ft to 170.6 ft)
Main boom head:	7 sheaves
Cylinder:	One single-level telescoping cylinder with locking / unlocking mechanism
Power unit group	M 1 (in accordance with ISO 4301 - 2)
Telescoping mechanism:	

Lattice extension

▣▣▣▣ *Operating Instructions Lattice Extension*

Operating speeds

The indicated operating speeds apply to an engine speed of approx. 2 300 rpm.

Hoists:	Rope speed when lifting and lowering
	Normal speed: maximum 60 m / min (197 ft / min)
	High speed: maximum 120 m / min (394 ft / min)
Slewing gear:	0 to 1.9 revolutions per minute
Telescoping mechanism:	Extending the main boom from 11.3 to 52.0 m (37 ft to 170.6 ft)
	approx. 450 s In automatic mode during uninterrupted locking and telescoping processes
Derricking gear:	Derricking between - 3° and 83°
	Normal speed: raising approx. 90 s
	High speed: raising approx. 50 s

Blank page

41005067

17 Index



41005067

17

Index



To avoid making the index unnecessarily long and unclear, we have not included every single element from the instrument panel. Those elements, such as switches and buttons, lamps and displays are described and named in detail in the overviews of chapter 3 and chapter 10, *Description of the truck crane*. You are referred to more detailed descriptions of these elements from there as usual.

41005067

Blank page

41005067

A	Access ladders on the carrier	4 - 5
	Adjusting the mirrors	
	for crane operation	13 - 114
	for driving	5 - 7
	Adjusting the seat	
	in the driver's cab	5 - 11
	Air intake inhibitor	4 - 23
	on the engine for crane operation	11 - 21
	Air-conditioning system	
	in the crane cab	12 - 125
	in the driver's cab	5 - 78
	Auxiliary heater	
	fuel reserve	12 - 5
	Auxiliary hoist	12 - 48
	lifting and lowering	12 - 49
	short description of the operating elements	10 - 70
	switching off	12 - 50
	switching on	12 - 48
	Axle loads	
	required speed limit	6 - 6
	when driving with a rigged truck crane	14 - 3
B	Battery master switch	4 - 8
	superstructure	11 - 7
	Boom floating position	
	switching off	13 - 17
	switching on	6 - 9
	Boom pre-tensioning	
	switching off	13 - 19
	switching on	6 - 10
	Brakes	
	additional brakes	3 - 45, 5 - 46
	compressed-air supply in the event of engine failure	7 - 6
	operating elements in the driver's cab	3 - 43
	parking brake	3 - 44
	checking for correct functioning	5 - 10
	towing a trailer	
	checking the braking force	5 - 90

C	Carrier hydraulic system	
	checking the valves on the hydraulic tank	4 - 8
	CHECKLIST	
	extending the outriggers	13 - 25
	if the temperature is low	
	crane operation	11 - 4
	driving	4 - 4
	inspections before on-road driving	5 - 1
	inspections prior to crane operation	12 - 1
	retracting the outriggers	13 - 27
	rigging counterweight	13 - 59
	rigging for crane operation	13 - 1
	starting the engine for crane operation	11 - 1
	unrigging counterweight	13 - 60
	unrigging following crane operation	13 - 5
	Choosing a site	13 - 9
	Compressed air system	
	building up supply pressure	5 - 9
	see Brakes	
	Constant speed	
	see Tempomat	
	Counterweight	
	automatic mode, rigging	13 - 74
	automatic mode, unrigging	13 - 75
	CHECKLIST	
	rigging counterweight	13 - 59
	unrigging counterweight	13 - 60
	counterweight parts	13 - 55
	counterweight versions	
	assembling	13 - 61
	overview, version A	13 - 64
	Overview, version B	13 - 66
	Overview, version C	13 - 68
	extending / retracting the lifting cylinders	13 - 73
	identification	13 - 57
	mounting counterweight on the turntable	13 - 78
	opening the submenu	13 - 72
	pre-tensioning	13 - 74
	removing counterweight from the turntable	13 - 79
	short description of the operating elements	10 - 65
	slewing with rigged counterweight	13 - 82
	slinging points	13 - 58
	Crane cab	
	adjusting the front panel and crane cab seat	12 - 7
	air-conditioning system	12 - 125
	drying the air	12 - 127
	auxiliary air heater	12 - 134
	auxiliary water heater	12 - 127
	door	10 - 97
	inclining	12 - 95
	operating elements	

auxiliary air heater	10 - 13
auxiliary water heater	10 - 12
control lever assignment	10 - 16
on the control panels	10 - 14
on the ECOS control unit	10 - 18
on the ECOS display	
main menu	10 - 20
submenus	10 - 22
on the front panel	10 - 6
on the hand-held control	10 - 44
on the outrigger control units	10 - 46
on the side panel	10 - 7
on the SLI control unit	10 - 40
standard heating system	10 - 11
overview	10 - 4
standard heating system	12 - 123
ventilating	12 - 124
windows	10 - 97
windscreen washing system	12 - 5
Crane cab, driving	14 - 7
after driving	14 - 21
operating the transmission	14 - 15
possible connections	14 - 19
longitudinal differential locks	14 - 20
preparations	14 - 8
starting	14 - 17
starting / turning off the engine	14 - 11
steering	
adapt steering direction	14 - 12
normal steering	14 - 13
separate steering	14 - 14
switching on the steering	14 - 12
warning messages	14 - 18
while driving	14 - 17
Crane operation	
CHECKLIST – inspections prior to crane operation	12 - 1
if the temperature is low – CHECKLIST	11 - 4
permissible slewing ranges	12 - 43
preheating the hydraulic oil	12 - 13
rigging – CHECKLIST	13 - 1
unrigging – CHECKLIST	13 - 5
what to do in the event of malfunctions	15 - 3
D Derricking gear	12 - 54
raising and lowering the boom	12 - 55
short description of the operating elements	10 - 73
switching off	12 - 56
switching on	12 - 54
Diagnostics plug	10 - 96

Differential locks	
see Longitudinal differential locks	
see Transverse differential locks	
Display, driver's cab	
messages while driving	5 - 50
overview	3 - 10
short description, on-board computer	3 - 54
Display, driver's cab	
on-board computer	
settings / displays	
operation	5 - 22
overview of the menus	5 - 23
Displays during crane operation	
error message	12 - 106
operating hours	12 - 101
warning message	12 - 102
Displays while driving	
error message	5 - 50
on the driving display	5 - 50
warning message	5 - 48
Documentation supplied	1 - 6
Driver's cab	
adjusting the mirrors	5 - 7
adjusting the seats	5 - 11
air-conditioning system	5 - 78
auxiliary heater	5 - 80
doors	3 - 57
keys	3 - 57
operating elements	
auxiliary air heater	3 - 25
on the ECOS display	3 - 16
on the instrument panel	3 - 7
on the steering column	3 - 11
standard heating system	3 - 24
transmission	3 - 12
overview	3 - 4
standard heating system	5 - 75
windows	3 - 56
Driving	
brakes	
additional brakes	5 - 46
downhill	5 - 44
if the temperature is low – CHECKLIST	4 - 4
inspections before driving	5 - 6
inspections before driving – CHECKLIST	5 - 1
inspections while driving	5 - 39
off-road	5 - 61
uphill	5 - 47
what to do in the event of malfunctions	7 - 3
with Tempomat	5 - 41
with tempopset	5 - 43

Driving from the crane cab	
opening/closing the Driving mode submenu	14 - 8
Driving modes	
tables for maximum axle loads of 12 t	6 - 3
using the tables	6 - 2
Driving the rigged truck crane	14 - 1
E Earthing	
of the truck crane	13 - 13
the load	12 - 12
ECOS	
adjusting the brightness of the display – in the crane cab	11 - 11
adjusting the brightness of the display – in the driver's cab	4 - 12
operating elements in the crane cab	
brief description	10 - 55
in counterweight submenu	10 - 22, 10 - 36
in submenu for outriggers	10 - 24
in the driving submenu	10 - 38
in the Error submenu	12 - 106
in the main menu	10 - 20
in the monitoring submenu	10 - 29
in the power unit speed submenu	10 - 28
in the Settings submenu	
operating hours	12 - 101
in the settings submenu	10 - 30
in the slewing gear/Houselock submenu	10 - 23
in the telescoping submenu	10 - 26
in the Warning submenu	12 - 102
on the control unit	10 - 18
operating elements in the driver's cab	
brief description	3 - 34
in the Error submenu	3 - 23, 5 - 50
in the level adjustment system submenu	3 - 18
in the main menu	3 - 16
in the Settings submenu	3 - 20
operating hours	5 - 21
in the Transmission emergency program submenu	3 - 22
in the Warning submenu	3 - 21, 5 - 48
on the control unit	3 - 14
Electrical system	
display and operating elements in the crane cab	10 - 89
fuses in the superstructure	15 - 6
inspections in the crane cab	12 - 7
inspections in the driver's cab	5 - 6
operating elements in the driver's cab	3 - 34
SLI fuses	15 - 11

Emergency operation	
emergency operation in coolant circuit	7 - 35, 15 - 55
hydraulic emergency operation	
activating/deactivating emergency operation	15 - 59
after emergency operation	15 - 66
connecting/disconnecting hoses	15 - 58
emergency supply of another crane	15 - 67
establishing the required hydraulic circuits	15 - 60
operating principle	15 - 57
hydraulic emergency operation BGR 159	15 - 57
telescoping mechanism	
emergency operation for retracting	15 - 36
inspections prior to emergency operation	15 - 36
performing mechanical emergency operations	15 - 37
procedures for retracting	15 - 36
entering the telescoping status after emergency operation	15 - 49
telescoping emergency program	15 - 39
with the hand-held control	15 - 51
Emergency stop devices	
Engine for crane operation	11 - 20
for the engine	4 - 22
Emergency stop switch	
for crane operation	15 - 1
for driving	7 - 1
Engine for crane operation	
after starting the engine	
lamp test / equalisation of the switching states	11 - 9
air intake inhibitor	11 - 21
inspections after starting the engine	11 - 14
inspections before starting the engine	11 - 7
malfunctions	15 - 13, 15 - 22
preheating	12 - 128
refuelling	
additional tank	11 - 6
standard tank	11 - 5
setting the idling speed	11 - 16
starting	11 - 12
starting – checklist	11 - 1
switch on the ignition	11 - 8
turning off	
during normal operation	11 - 19
in emergencies	11 - 20
Engine for driving	
air intake inhibitor	4 - 23
diagnostics	3 - 53
malfunctions	7 - 23
operation in the driver's cab	
checking after starting	4 - 16
checking the fuel level	4 - 7
checks before starting	4 - 8
control elements	4 - 17
lamp test / equalisation of the switching states	4 - 10

resetting the emergency stop switch	4 - 22
setting the idling speed	4 - 19
starting	4 - 13
starting – CHECKLIST	4 - 1
switching on the ignition	4 - 9
turning off	4 - 21
procedure in the event of malfunctions	7 - 36
refuelling	4 - 7
starting from the crane cab – for rigging work	13 - 21
Engine, for crane operation	
short description of the operating elements	10 - 51
F Final drive	
operating elements in the driver's cab	3 - 42
Front flap	
opening and closing	3 - 58
Fuel tank	
engine for crane operation	11 - 5
standard tank	4 - 7
Fuses	
on the carrier	7 - 17
in the battery box	7 - 22
in the driver's cab	7 - 18
on the superstructure	15 - 5
for the SLI	15 - 11
in the crane cab	15 - 8
on the turntable	15 - 6
H Hand-held control	
disconnecting	13 - 20
malfunctions	15 - 22
Heating system	
crane cab	
auxiliary air heater	12 - 134
auxiliary water heater	12 - 127
standard heating system	12 - 123
driver's cab	
auxiliary heater	5 - 80
standard heating system	5 - 75
High speed	12 - 86
derricking gear / telescoping mechanism high-speed mode	12 - 86
high-speed mode, hoisting gears	12 - 87
switch on function	12 - 86

Hoist rope	
checking the position	12 - 6
positioning and reeving in	13 - 92
possible reevings on the main boom	
with 7 head sheaves	13 - 96
with 8 head sheaves	13 - 99
rope end clamp	13 - 90
unreeving	13 - 95
Hook block	
attaching it to the bumper	13 - 86
picking it up from the separate vehicle	13 - 87
picking up from the bumper	13 - 85
placing it on a separate vehicle	13 - 87
Horn	3 - 48
Houselock	
switching off	12 - 16
switching on	12 - 14
Hydraulic system of the superstructure	
check valve on hydraulic tank	11 - 7
hydraulic oil cooling	12 - 93
preheating the hydraulic oil	12 - 13
Hydraulic system, superstructure	
short description of the operating elements	10 - 81
I Identification	
of the counterweight sections	13 - 57
of the truck crane	1 - 1
Inclination display	
short description of the operating elements	10 - 63
Inclination displays	13 - 46
Information	
about the operating instructions	1 - 7
conversion table for US measurements	1 - 15
for operations planning	1 - 14
technical information on the carrier	8 - 1
Inspections	
before driving	5 - 6
for the safety devices	12 - 9
vehicle height	5 - 8
Installing / removing the air traffic control light	13 - 108
Installing / removing the anemometer	13 - 108

K	Keys	
	for the carrier	3 - 57
	for the superstructure	10 - 98
L	Ladders and access ladders	4 - 5
	Level adjustment system	
	changing the vehicle level	5 - 67
	exiting the submenu	5 - 68
	opening the submenu	5 - 65
	operating elements	3 - 50
	pre-selecting suspension struts	5 - 66
	setting the on-road level	5 - 66
	viewing the current inclination	5 - 67
	Lifting limit switch	
	installing	13 - 102
	locking	13 - 106
	removing	13 - 105
	removing the lock	13 - 107
	Lighting	3 - 49
	driver's cab, inside	3 - 50
	hazard warning system	3 - 49
	operating elements in the crane cab	10 - 89
	outriggers	3 - 49
	parking light / headlight – full beam	3 - 48
	rotating beacon	3 - 49, 3 - 50
	superstructure lighting	6 - 12
	turn signal indicator	3 - 48
	Load, earthing	12 - 12
	Longitudinal differential locks	
	operation from the crane cab	14 - 20
	operation from the driver's cab	5 - 63
	while towing	7 - 8
M	Main boom	
	lower to the horizontal	12 - 56
	Main hoist	12 - 45
	folding hoist mirror out / in	13 - 114
	lifting and lowering	12 - 46
	short description of the operating elements	10 - 68
	switching off	12 - 47
	switching on	12 - 46
	Malfunctions	
	carrier hydraulic system	7 - 28
	counterweight hoist unit	15 - 21
	derricking gear	15 - 16
	differential locks	7 - 28

during crane operation	15 - 3
ECOS – carrier	7 - 30
error display on the control units	7 - 33
error messages on the display	7 - 31
ECOS – superstructure	15 - 32
error messages	15 - 33
engine	
in crane operation	15 - 22
in driving mode	7 - 23
engine for crane operation	15 - 13
hand-held control	15 - 22
hydraulic system of the superstructure	15 - 22
inclining the crane cab	15 - 22
level adjustment system	7 - 29
main hoist	15 - 15
outriggers	15 - 24
procedure in the event of malfunctions	7 - 35
safe load indicator	15 - 25
service brake	7 - 26
slewing gear	15 - 20
steering	7 - 27
suspension	7 - 29
telescoping mechanism	15 - 17
transmission	7 - 25, 7 - 27
when driving from the crane cab	15 - 23
Movement combinations	
when operating with the main boom	12 - 92
O Off-road driving	5 - 61
On-board computer	
general operation	3 - 54
Operating elements	
for driving from the crane cab	10 - 99
in the crane cab – overview	10 - 4
in the driver's cab – overview	3 - 4
Operating instructions	
example of how to use cross-references	1 - 12
finding information	1 - 11
structure of the chapters and pages	1 - 9
symbols used	1 - 7
Outrigger pressure display	13 - 53
Outrigger pressure displays	
short description of the operating elements	10 - 64
Outriggers	13 - 25
CHECKLIST – Extending	13 - 25
CHECKLIST – Retracting	13 - 27
determining the required ground bearing area	13 - 9
enlarging the ground bearing area	13 - 39
extending / retracting outriggers	13 - 32

	from the control units	13 - 33
	from the crane cab	13 - 36
	with the hand-held control	13 - 34
	extending / retracting supporting cylinders	13 - 41
	from the control units	13 - 42
	from the crane cab	13 - 44
	with the hand-held control	13 - 43
	levelling the truck crane on outriggers	
	automatically	13 - 49
	inclination displays	13 - 46
	manually	13 - 48
	outrigger pads	
	moving into driving position	13 - 38
	moving into working position	13 - 38
	outrigger pressure display	13 - 53
	permissible outrigger spans	13 - 28
	preparing the truck crane for rigging	13 - 29
	setting the spans	13 - 30
	short description of the operating elements	10 - 58
	Overview	
	operating elements – crane operation	10 - 1
	operating elements – driving	3 - 1
P	Parking brake	
	operating elements	3 - 44
	while towing	7 - 8
	Push-up roof	3 - 56
R	Railings on the turntable	13 - 113
	Refuelling	
	standard tank	4 - 7
	Rigged truck crane, driving	
	axle loads	14 - 3
	before driving	
	checking the tyre pressure/wind speed	14 - 4
	driving from the driver's cab	14 - 5
	rigging modes	
	driving with load	14 - 3
	driving without a load	14 - 2
	route	14 - 2
	Rigging for on-road driving	
	for driving with a trailer	6 - 7
	switching on boom floating position	6 - 9
	switching on boom pre-tensioning	6 - 10
	switching on the slewing gear freewheel	6 - 8
	switching the superstructure driving lights on / off	6 - 12

Rigging mode	
entering on the SLI	12 - 21
Rigging work	
main boom	
attaching the hook block to the bumper	13 - 86
picking up the hook block from the bumper	13 - 85
picking up the hook block from the separate vehicle	13 - 87
placing the hook block on the separate vehicle	13 - 87
other rigging work	
folding mirror in / out	13 - 114
folding out the railings on the turntable	13 - 113
outriggers	13 - 25
rigging for crane operation – CHECKLIST	13 - 1
unrigging following crane operation – CHECK LIST	13 - 5
Rotating beacons (controlled from the crane cab)	10 - 89
S Safe distance	
from electrical lines	13 - 14
to slopes and pits	13 - 12
Safe load indicator	
short description of the operating elements	10 - 83
Safety	
basic safety instructions	2 - 1
intended use	2 - 1
Safety devices	
checking	12 - 9
Seat, adjusting	
in the crane cab	12 - 7
Separate steering	5 - 71
steering with separate steering	5 - 72
switching to normal steering mode	5 - 73
switching to separate steering	5 - 71
Settings before driving	
adjusting the brightness of the display	4 - 12
Settings during crane operation	
adjusting the brightness of the display	11 - 11
adjusting the power unit speeds	12 - 96
adjusting the wiper stroke interval	12 - 96
critical load control	12 - 99
directional spotlights	12 - 100
inclining the crane cab	12 - 95
setting the characteristic curve for the control levers	12 - 98
setting the constant idling speed	12 - 95
Slewing gear	
braking the slewing movement	12 - 91
short description of the operating elements	10 - 71
slewing	12 - 88

slewing gear freewheel	12 - 91
slewing to 0° and 180°	12 - 90
switching off	12 - 92
Slewing gear freewheel	
switching off	13 - 18
switching on	6 - 8
SLI	
displaying / entering the time and date	12 - 39
during crane operation	12 - 31
entering the rigging mode	12 - 21
finding and eliminating malfunctions	15 - 25
error messages	15 - 26
general malfunctions	15 - 25
fuses	15 - 11
lamp test	12 - 20
operating elements	10 - 40
overriding the SLI	12 - 38
SLI early warning	12 - 35
SLI shutdown	12 - 36
due to overload	12 - 36
switching on	12 - 18
SLI lamp test	12 - 20
Spotlights	10 - 89
Starting to tow	7 - 10
Steering	
in the crane cab	14 - 12
operating elements in the driver's cab	3 - 46
Steering column	
adjusting	5 - 13
Storage compartment	3 - 58
Superstructure lock	
see houselock	
Suspension	
locking (switching off)	5 - 14
operating elements in the driver's cab	3 - 47
switching on / off	5 - 14
T Tachograph	5 - 16
inserting diagram sheets	5 - 18
setting time groups	5 - 19
Tachograph / speedometer	
operating elements	3 - 52
Technical data	8 - 1, 16 - 1
carrier	8 - 5
dimensions and weights of removable parts	8 - 4, 16 - 2
dimensions, weights, axle loads of the truck crane	8 - 2
maximum lifting capacity	16 - 1

operating speeds	16 - 5
superstructure	16 - 4
Telescoping mechanism	12 - 57
assignment for display	12 - 60
error messages	15 - 18
function of the control lever	12 - 65
inspections prior to starting operations	12 - 64
main boom fixed length	12 - 62
main boom intermediate length	12 - 62
main boom telescoping length	12 - 62
manual telescoping	12 - 68
checking the initial position	12 - 68
extending / retracting the telescoping cylinder	12 - 73
locking the telescopic section	12 - 78
locking the telescopic section for on-road driving	12 - 79
telescoping the telescopic section	12 - 77
unlocking the telescoping cylinder	12 - 71
overview	12 - 58
short description of the operating elements	10 - 74
switching off	12 - 67
switching on	12 - 65
telescopic extension with teleautomation	12 - 80
telescoping process	12 - 58
telescoping sequence	12 - 63
telescoping the main boom for maintenance	12 - 85
telescoping the main boom in horizontal position	12 - 85
telescoping, ECOS display	12 - 77
telescoping, SLI display	12 - 63
Tempomat	5 - 41
Temposet	5 - 43
Towing	7 - 5
compressed-air supply in the event of engine failure	7 - 6
electric power supply	7 - 6
in the event of engine or transmission damage	7 - 6
parking brake	7 - 8
towing the truck crane out of the danger area	7 - 9
Towing a trailer	5 - 85
Towing free	
backwards	5 - 70
forwards	5 - 70
Transfer case	5 - 62
operating elements in the driver's cab	3 - 41
Transmission	
diagnostics plug	3 - 53
ID number	7 - 45
operating in the emergency program	7 - 38
operation from the driver's cab	
changing gears while driving	5 - 34
changing the driving direction	5 - 36
changing the operating mode	5 - 30
display of the gears	5 - 31

on the roller type dynamometer	5 - 37
selecting and changing the starting gear	5 - 31
starting	5 - 33
stopping	5 - 37
switching on	5 - 29
switching to neutral position	5 - 30
procedure in the event of malfunctions	7 - 36
switching gears mechanically in emergency mode	7 - 41
Transverse differential locks	
operation from the crane cab	14 - 20
operation from the driver's cab	5 - 63
while towing	7 - 8
Trip recorder	
see Tachograph	
Truck crane	
checking the horizontal alignment	12 - 41
earthing	13 - 13
Identification	1 - 1
overview of the carrier	3 - 2
rocking free	5 - 69
safe distance	12 - 41
securing against rolling away	5 - 58
towing free	
backwards	5 - 70
forwards	5 - 70
turning off	5 - 58
Tyres	
see Wheels and tyres	
V Voltage indicator lamp	
carrier	4 - 18
superstructure	10 - 89
W Warning plates for vehicle width	5 - 8
Welding work	
safety instructions	2 - 4
Wheels and tyres	
filling the tyres yourself	7 - 15
wheel change	7 - 11
Windscreen washing system	
tank – driver's cab	5 - 6
Windscreen wiper	3 - 48
crane cab	10 - 91
driver's cab	3 - 48
Windscreen wiper / washing system	10 - 89

Windscreen, washing system	
tank – driver's cab	12 - 5
Work break	12 - 121
short work breaks	12 - 121
work breaks of more than 8 hours	12 - 122
Working range limiter	12 - 107
entering limit values by approaching them	
for objects	12 - 113
for overall height / working radius	12 - 110
for slewing angles	12 - 111
entering limit values manually	
for objects	12 - 117
for overall height / working radius / slewing angle	12 - 116
opening the Working range limiter submenu	12 - 108
shutdown	12 - 119
switching monitoring function on / off	12 - 118
view current settings	12 - 108

41005067

GROVE®

GMK 4100

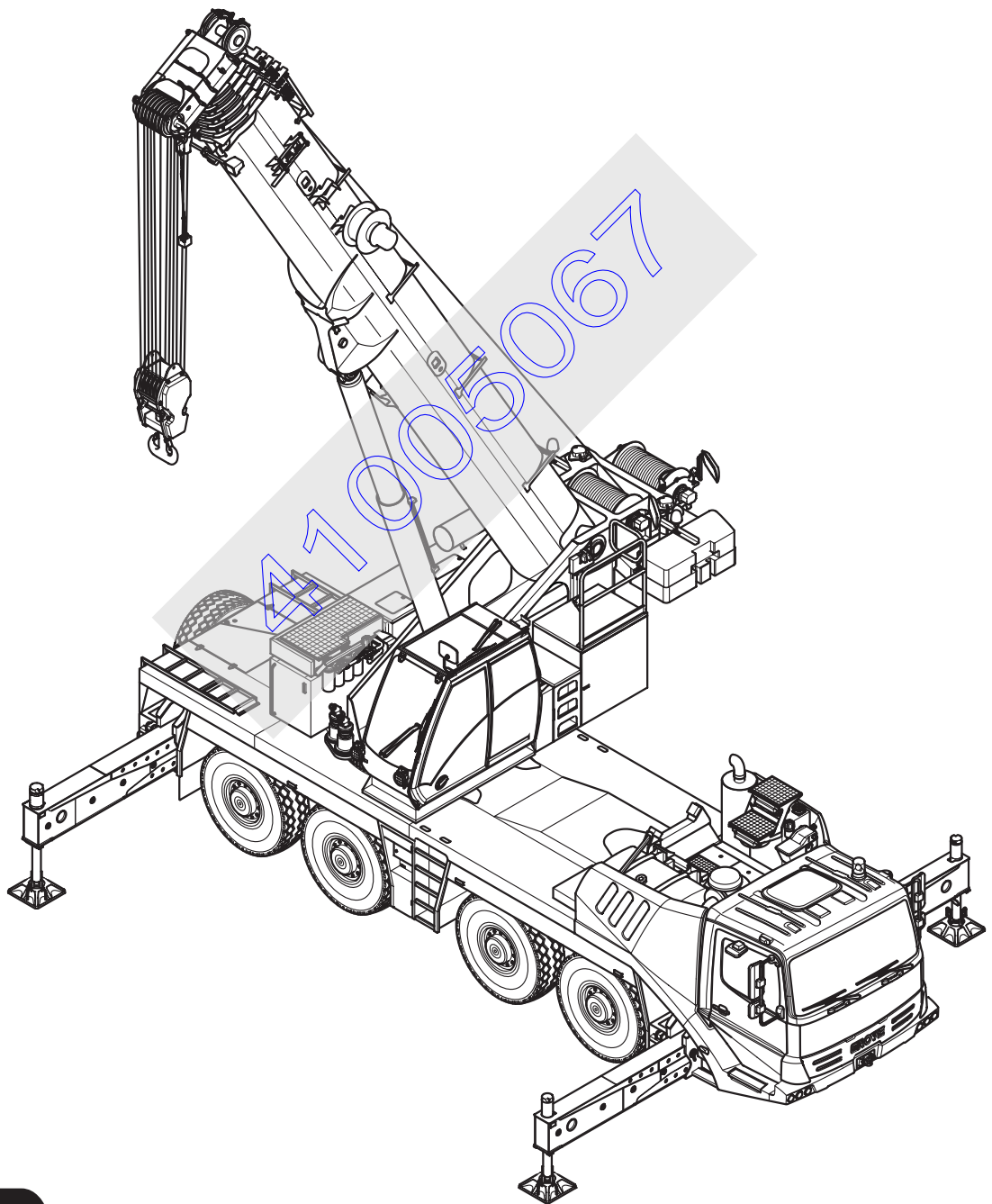

41005067

Manitowoc Crane Group Germany GmbH

Industriegelände West,
D-26389 Wilhelmshaven, Germany
Postfach 18 53,
D-26358 Wilhelmshaven, Germany
Fax: Int [+49] (0) 44 21 294-301
Tel: Int [+49] (0) 44 21 294-0
www.manitowoccranegroup.com