

GROVE®

GMK 5220

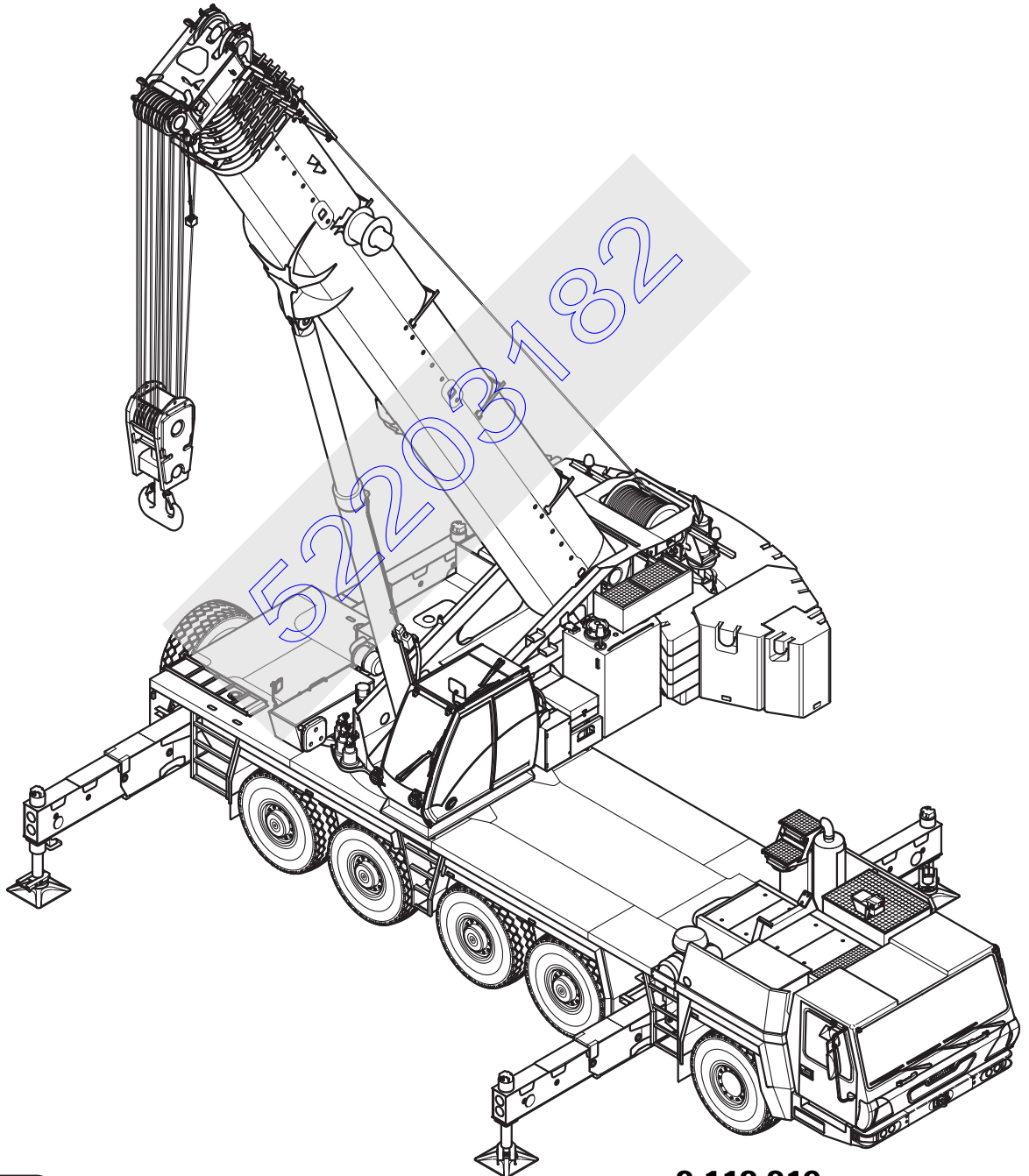

Lattice extension operating instructions



Serial number

**3 112 319 en
08.09.2006**

Manitowoc®
Crane Group

A **Manitowoc** Company

Important note

Duplications of any kind and excerpts from this document are not subject to the revision service. Original documents of Deutsche GROVE GmbH are marked with the blue serial number of the truck crane on the cover sheet.

Duplications and printouts of data carriers on which Deutsche GROVE GmbH has delivered this document are also not subject to the revision service.

52203182

© Copyright reserved by **Deutsche GROVE GmbH**

Dissemination or duplication of this document as well as utilization and disclosure of its contents are prohibited unless expressly permitted. Infringement will incur liability for compensation. All rights pertaining to registration of patent or utility model are reserved.

08.09.2006

Setting the angle position of the heavy load lattice extension

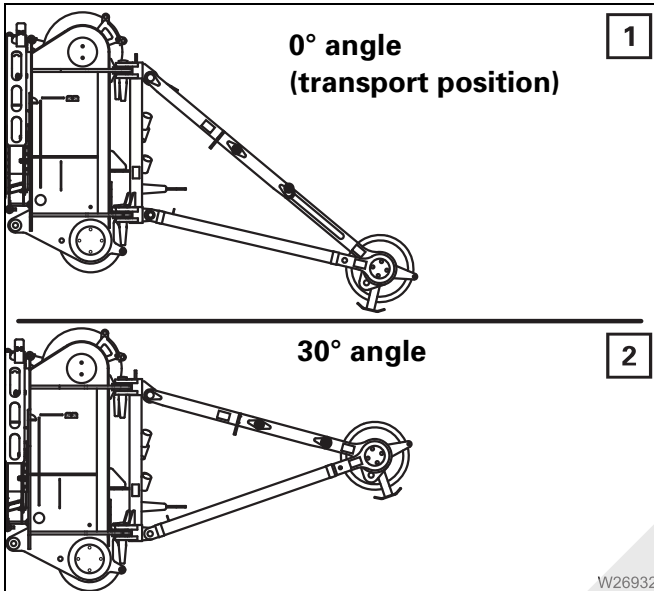

In section 6.4.3 in paragraph *Setting the angle position* the texts (1) and (2) have been assigned to the illustrations incorrectly.

The text next to the illustration is correct.

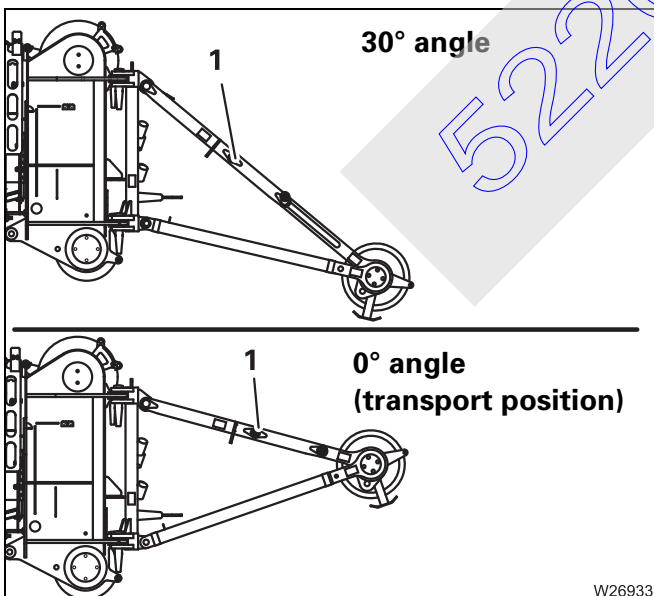

The illustration to the left shows the correct assignment of the texts.

52203182

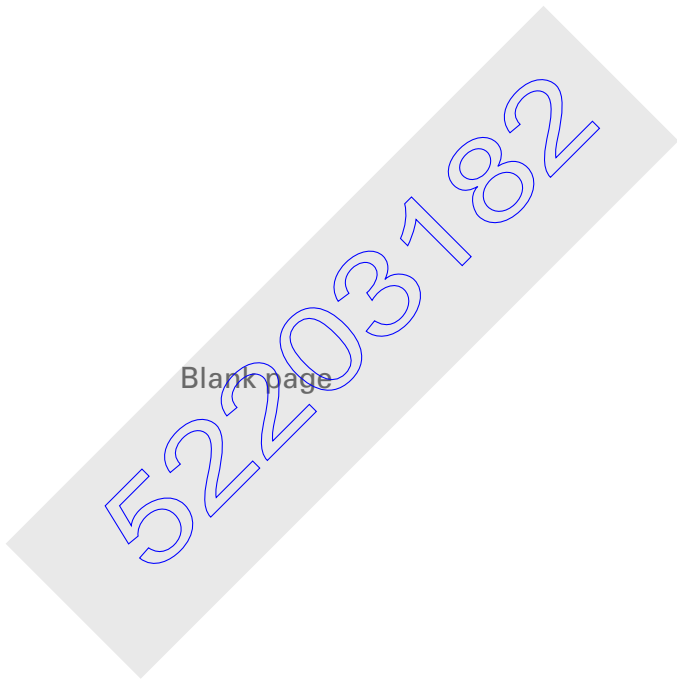

These operating instructions contain the following chapters:

- 1 Important information**
- 2 Transport dimensions and weights**
- 3 12/21 m (39/69 ft) swing-away lattice extension**
- 4 Boom extension**
- 5 Auxiliary single-sheave boom top**
- 6 Heavy load lattice extension**
- 7 Index**

52203182

52203182

1 Important information

1.1 About these operating instructions. 1 - 1

1.2 Basic safety instructions. 1 - 2

1.2.1 Warnings and symbols 1 - 2

1.3 Intended use 1 - 3

1.4 Organizational measures 1 - 5

1.5 Personnel qualifications 1 - 7

1.6 Safety instructions for truck crane work. 1 - 8

1.7 Specifications in US standard units of measurement 1 - 10



52203182

1

Important information

1.1

About these operating instructions



All the lattice extensions described in these operating instructions can be obtained as additional equipment.

Validity of these operating instructions

These operating instructions only apply to lattice extensions which were delivered by Deutsche GROVE GmbH.

When operating the truck crane with one of the lattice extensions described in these operating instructions, you must also follow all the information in the *Operating instructions* supplied with the GMK 5220 which was equipped at the factory with the lattice extension.

Prerequisites for assembly and operation

The lattice extensions described in these operating instructions may only be operated together with the GROVE GMK 5220 truck crane whose serial number is identical with the serial number marked on the lattice extensions.

Safety instructions

The operation of GMK 5220 with one of the lattice extensions described in these operating instructions is subject to:

- all the basic safety instructions to be found in the subsequent section *Basic safety instructions* **and**
- all the safety instructions contained in the operating instructions supplied with the GMK 5220.

References to other operating instructions

Cross references to other operating or maintenance instructions are shown in the following forms:

▣▣▣▣ *GMK 5220 operating instructions, Part 2 Crane operation – Rigging work*
The number for the chapter on *Rigging work* is found at the front, on the second page of the operating instructions specified.

or

▣▣▣▣ *GMK 5220 operating instructions – Safe load indicator*

The corresponding page number can be found in the index, under the entry *Safe load indicator*.

1.2 Basic safety instructions

1.2.1 Warnings and symbols

The following definitions and symbols are used in the operating instructions to highlight particularly important information:



This symbol indicates hazards related to the operation described which may cause personal injury. The type of danger (e.g. risk of fatal or non-fatal injury, or risk of crushing) is normally specified before the warning.



This symbol indicates dangers which could put objects at risk, e.g. damage to the truck crane, the load or the environment.



This symbol alerts you to situations where there is a risk of receiving an electric shock.



This symbol reminds you that you are working with substances which pose a risk to the environment. Take particular care. Further information on handling substances that pose a risk to the environment;  *Maintenance manual, Chapter Safety and environmental protection.*

The vertical line to the left of the warning text indicates the following: this text, regardless of its length, relates to the warning symbol.



The hand with the pointing finger indicates passages that contain additional instructions and tips regarding truck crane operation.



This symbol indicates that the topic is continued on the next page. Turn to the next page.

1.3

Intended use

The GMK 5220 truck crane is constructed in accordance with the latest technology and the recognized safety regulations. Nevertheless, personal injury to the operator or a third party as well as damage to the crane and other property may occur during use.

The truck crane may only be modified with the consent of the manufacturer.

The GMK 5220 truck crane may only be used when in excellent working condition and for its intended purpose, and with due attention to safe operation and any possible hazards.

Malfunctions that may affect safe operation are to be corrected immediately.

The GMK 5220 truck crane may only be operated at temperatures of between -25°C and $+40^{\circ}\text{C}$ (between -13°F and $+104^{\circ}\text{F}$) if unless equipped with the relevant special equipment.

The GMK 5220 truck crane may only be used to vertically lift loads in the authorized rigging modes using a hook block that is reeved to the hoist rope. The weight and centre of distribution of the loads must be known. Any other use of the crane is not considered to represent intended use.

The manufacturer is not liable for damage resulting from the improper or unauthorized use of the truck crane GMK 5220. The user shall take full responsibility for any such use.

Intended use also entails the following:

- Observing the complete crane documentation consisting of the operating instructions, the lifting capacity table, the outrigger pressure table and the safety manual
- Adhering to the inspection and maintenance requirements specified in the maintenance manual.



Improper use includes:

- Transporting loads on the carrier
- Pushing, pulling or lifting loads with the level adjustment system, the beams or the outrigger cylinders
- Pushing, pulling or lifting loads off the ground using the slewing gear, the derricking gear or the telescoping mechanism
- Pulling off fixed objects using the crane
- Two-hook operation with the boom extension and two-hook operation on the main boom head without additional equipment
- Defining SLI codes that do not correspond to the actual rigging mode
- Working with an overridden SLI or overridden lifting limit switch
- After SLI deactivation, increasing the radius by pulling the raised load at an angle (e.g. with a chain hoist)
- Misuse of the outrigger pressure indicator (additional equipment) as a safety function to prevent overturning after an SLI shutdown (outrigger pressure greater than 0 t)
- Road driving in an unauthorized driving mode (axle load, dimension)
- Moving the rigged crane in an unauthorized driving mode
- Use of equipment that is not authorized for use with the crane
- Transporting people in any way with the lifting tackle, upon the load, or in the crane cab while driving
- Carrying passengers outside the driver's cab
- Loading and unloading work, i.e. continuous operation without a sufficiently long break
- Usage for any kind of sport or recreation event, especially for bungee jumping

1.4

Organizational measures

The operating instructions and the lifting capacity table should be kept in the truck crane for immediate access at all times, and must not be removed from the truck crane. You must have read and understood the operation and safety instructions in these operating instructions, and comply with them when working.

In addition to the operating instructions and the lifting capacity table, observe all general, statutory and otherwise applicable regulations concerning accident prevention and environmental protection. You must have read and understood these and must comply with them when working.

These could include:

- How to deal with hazardous materials
- Wearing personal protective equipment
- Traffic regulations
- All applicable regulations concerning the operation of a crane

Ensure that those appointed to work on the truck crane are given the information required to carry out the work before starting operations. Instruct your employees (e.g. banksmen, slingers, rigging personnel) accordingly.

Ensure that the maintenance personnel have the necessary expertise to safely operate the crane. Ensure that the maintenance personnel have access to the operating instructions.

Only properly trained or instructed personnel may carry out work on the truck crane.

Responsibilities related to crane operation, rigging, maintenance and repair work must be clearly defined.

Ensure that only the appointed employees operate the truck crane.

Do not leave long hair down or wear loose clothing or jewellery (including rings) when working with the crane. These could get caught or pulled in and lead to injury.

Use your personal protective equipment whenever necessary or prescribed.

Observe all safety and warning signs on the truck crane.



Ensure that all safety and warning signs on the truck crane remain legible.

Note the operational organization on the site. Report your arrival to site management. Ask for the employee authorized to instruct you.

Familiarize yourself with the location and operation of the fire extinguishers on every site.

Note the fire alarm and fire fighting facilities on the site.

Should the operating behaviour of the truck crane change in such a manner that the safety conditions are affected, e.g. if you doubt the truck crane's operating safety, stop the machine immediately and inform the appropriate persons responsible.

Do not make any changes to the programmable control systems (e.g. the SLI).

Do not modify or mount attachments to the truck crane without the consent of the manufacturer, if such changes could affect the safety of the unit. This also applies to

- the installation of safety devices.
- the adjustment of safety devices and valves.

Welding work on load-bearing parts may only be carried out by properly qualified personnel with the manufacturer's prior permission. To avoid any damage, especially to electronic parts, there are certain steps you must take before doing any welding work. You should therefore always consult **CraneCARE** before doing any welding work.

Ensure that both the prescribed periods and the periods specified in the operating and maintenance instructions for regular testing, inspection and maintenance work are maintained.

Replace the hydraulic hose lines, or have them replaced, at the prescribed intervals, even if no safety defects are noticeable.

Replacement parts must fulfil the technical requirements prescribed by the manufacturer. Genuine spare parts always meet these requirements.

It is imperative that appropriate service equipment be used when carrying out repair work.

1.5

Personnel qualifications

These operating instructions are not a training manual for prospective crane operators.

All descriptions are written explicitly for crane operators who have been trained to operate truck cranes.

Employees in training may only operate the truck crane under strict supervision.

Only reliable personnel may operate the truck crane.

As a truck crane operator you are obliged to fulfil a number of requirements:

- You must possess a driving licence for this type of vehicle that is valid in the country in which you are working.
- You must have general knowledge of crane operation and any qualifications that may be required by the country in which you are working.
- You must be familiar with and have understood the operating instructions.
- You must be familiar with and have understood the accident prevention regulations.
- You must fulfil all physical and mental requirements for truck crane operation, e.g. perfect sight and hearing and the ability to react quickly.

Please refer to the section in the *Safety manual* titled *You as crane driver and operator*.

Only experienced personnel familiar with the applicable accident prevention regulations are authorized to sling loads and to train crane operators.

Your responsibilities as a crane operator (including those concerning traffic regulations) must be clearly defined. You must be in a position to refuse to carry out any instructions given to you by a third party that violate safety regulations.

Only trained personnel with special knowledge and experience in the fields of hydraulics, pneumatics and electrical equipment may carry out maintenance work on the truck crane.

Deutsche GROVE GmbH conducts general and type-related crane operator courses and technical courses.

1.6

Safety instructions for truck crane work

Carefully select a safe site for the truck crane to stand from where you can work safely.

Check over the truck crane before beginning crane work. Check the condition of the truck crane carefully using the checklists in the operating instructions. Do not assume that everything is in working order simply because it was in working order when work was last completed.

Check daily before starting to work with the crane that all guards and safety devices are correctly fitted and that they are all in a proper condition.

Check the safety devices each day before beginning work (SLI, lifting limit switch, dead man's switch, emergency stop switch for crane control).

Use the appropriate access aids when carrying out overhead rigging or maintenance work. Do not use parts of the crane as access aids.

Walk only on those machine parts which are equipped with appropriate steps and railings and therefore guarantee safety. During rigging and maintenance work on machine sections above body height which have no apparatus for accessing them, always use the extension ladder supplied (e.g. when reeving the hoist rope on the boom head).

Keep all handles, steps, step treads and ladders free of dirt, snow and ice.

Check all operating and control elements in the crane cab before starting the diesel engine.

Monitor all warning and indicator lamps as well as the control instruments when the engine is started.

Make sure that there are no unauthorized people in the vicinity of or on the truck crane when rigging or during crane work. Secure the danger zone using cordons and mark the zone as such.

When lifting a load, raise the boom to balance out the increase in radius caused by the boom bending so that the load is lifted up vertically and does not drag, injure helpers or fall into the hoist rope diagonally (e.g. from a vehicle or scaffolding). Inform banksmen and helpers about this as well.

Before turning the superstructure, support the truck crane with the outrigger span required for the currently rigged counterweight.

Ensure that the truck crane is horizontally aligned before carrying out crane work.

Only use equipment (counterweight sections, lattice extensions) that belongs to your truck crane. Both the truck crane and the equipment must have the same serial number.

Simultaneously lifting loads with two cranes is particularly dangerous. Use extreme caution when carrying out this type of work.

When work is interrupted, always put the load down and never leave the truck crane if a load is raised.

Lock the truck crane when you leave the cab to prevent unauthorized use.

Crane work carried out in the vicinity of live electrical cables as well as oil, gas or other supply lines is dangerous and requires that special precautionary measures be taken. Please refer to the section titled *Crane operation under special operating conditions* in the *Safety manual*, and observe the relevant national regulations.

52203192

1.7**Specifications in US standard units of measurement**

In these operating instructions, the lattice extension lengths are given in metric units and US standard units of measurement. The values for the US standard units are rounded to the nearest whole number. For this reason, these values deviate from the specifications in the *Lifting capacity table*.

The following table compares the two.

Given length in metric units of measurement	Corresponding length in US standard units acc. to lifting capacity table	Rounded length in US standard units in these operating instructions
12 m	39.4 ft	39 ft
21 m	68.9 ft	69 ft
29 m	95.1 ft	95 ft
37 m	121.4 ft	121 ft

52203182

2 Transport dimensions and weights

2.1	Swing-away lattice extension	2 - 1
2.2	Auxiliary single-sheave boom top	2 - 2
2.3	Heavy load lattice extension	2 - 2

52203182

52203182

2

Transport dimensions and weights

2.1

Swing-away lattice extension

Description	Length x width x height in m (ft)	Weight in kg (lbs)
21 m (69 ft) swing-away lattice extension, complete, folded	12.7 x 1.1 x 1.5 (42.0 x 3.6 x 5.0)	2 010 (4 430)
Section 1	12.7 x 1.1 x 1.5 (42.0 x 3.6 x 5.0)	1 530 (3 380)
Section 2	9.1 x 0.6 x 0.8 (30.0 x 2.0 x 2.7)	451 (1 000)
Section 3 – with deflection sheave	8.2 x 0.9 x 1.2 (20.4 x 3.0 x 4.0)	654 (1 440)
Section 4 – without deflection sheave	8.2 x 0.9 x 1.2 (20.4 x 3.0 x 4.0)	632 (1 400)

2.2

Auxiliary single-sheave boom top

Description	Length x width x height in m (ft)	Weight in kg (lbs)
Auxiliary single-sheave boom top complete with pins	1.1 x 0.9 x 1.0 (3.6 x 3.0 x 3.3)	60 (135)

2.3

Heavy load lattice extension

Description	Length x width x height in m (ft)	Weight in kg (lbs)
Heavy load lattice extension approx. 2.0 m	1.9 x 1.1 x 1.1 (6.3 x 3.6 x 3.6)	340 (750)

52203182

3 12/21 m (39/69 ft) swing-away lattice extension

3.1	Additional operating and display elements	3 - 1
3.1.1	In the crane cab	3 - 1
3.1.2	Operating and display elements on the hand-held control	3 - 5
3.1.3	Operating and display instruments on the swing-away lattice extension	3 - 6
3.2	Identification of the swing-away lattice extension	3 - 7
3.3	Composition of the swing-away lattice extension.	3 - 9
3.4	Centres of gravity for slinging	3 - 10
3.5	Checklists for rigging work.	3 - 11
3.5.1	Overview of the required rigging work	3 - 11
3.5.2	CHECKLIST: Installing the 12/21 m (39/69 ft) swing-away lattice extension	3 - 12
3.5.3	CHECKLIST: Removing the 12/21 m (39/69 ft) swing-away lattice extension	3 - 14
3.5.4	CHECKLIST: Rigging the 12/21 m (39/69 ft) swing-away lattice extension	3 - 19
3.5.5	CHECKLIST: Unrigging the 12/21 m (39/69 ft) swing-away lattice extension	3 - 25
3.6	Description of rigging work	3 - 31
3.6.1	Preparing the truck crane for rigging	3 - 31
3.6.2	Checking the transport condition	3 - 33
3.6.3	Checking the locking device on the hose drum.	3 - 38
3.6.4	Installing/removing the hose drum	3 - 41
3.6.5	Establishing/disconnecting the hydraulic connection	3 - 43
3.6.6	Folding the run-up rail out/in	3 - 45
3.6.7	Connections with folded lattice extension.	3 - 46
3.6.8	Connecting/disconnecting the slewing connection	3 - 58
3.6.9	Connections on the left and right of the main boom head	3 - 60
3.6.10	Swinging the lattice extension onto the main boom head	3 - 64
3.6.11	Swinging the lattice extension when rigging	3 - 65
3.6.12	Establishing/releasing connections on the lattice extension	3 - 69
3.6.13	Electrical connections on the lattice extension	3 - 74
3.6.14	Folding deflection sheave out/in.	3 - 77
3.6.15	Positioning/removing the hoist rope	3 - 80
3.6.16	Installing/removing the lifting limit switch	3 - 82
3.6.17	Installing/removing the anemometer.	3 - 85
3.6.18	Air traffic control light – electrical connection.	3 - 89
3.6.19	Derricking the lattice extension	3 - 91
3.6.20	Transportation on a separate vehicle.	3 - 94



3.7	Operation with the lattice extension	3 - 95
3.7.1	Setting	3 - 96
3.7.2	Raising and setting down the main boom	3 - 98
3.7.3	Telescoping with rigged lattice extension	3 - 99
3.7.4	Information about the SLI shutdown	3 - 100
3.7.5	Procedure if the permissible wind speed is exceeded	3 - 101
3.7.6	Information about the main boom operation when the lattice extension is folded/rigged	3 - 102
3.8	Turning loads with the lattice extension	3 - 105
3.8.1	Prerequisites	3 - 105
3.8.2	Setting the SLI	3 - 106
3.8.3	Turning a load	3 - 108
3.9	Driving with rigged truck crane and rigged lattice extension	3 - 111
3.9.1	Driving route	3 - 112
3.9.2	Boom positions and axle loads	3 - 113
3.9.3	Driving the rigged crane	3 - 116
3.10	Finding and eliminating malfunctions	3 - 121
3.11	Maintenance work	3 - 123
3.11.1	Modules in need of protection during cleaning work	3 - 123
3.11.2	Maintenance work M1, monthly	3 - 124
3.11.3	Maintenance work M12, every twelve months	3 - 125

52203182

3

12/21 m (39/69 ft) swing-away lattice extension

3.1

Additional operating and display elements

When the GMK 5220 is equipped with swing-away lattice extension, certain operating and display elements in the crane cab also apply to the operation of the lattice extension. The following sections describe:

- all operating and display elements **in the crane cab** required for the operation of the lattice extension.
- all operating and display elements on the **hand-held control** required for the operation of the lattice extension.
- the operating elements located directly **on the swing-away lattice extension**.

3.1.1

In the crane cab

In the crane cabin there are additional operating and display elements on the right control console on the display *Crane control* and on the plug-in module of the safe load indicator.

At the control console, right

The hydraulically derricked lattice extension has an additional rocker button on the right control panel and the right control lever has an additional function.

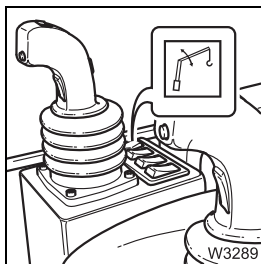

The rocker button *Derricking lattice extension on/off (1)* is used to switch the lattice extension derricking gear on and off.

There is an indicator lamp in the rocker button. The indicator lamp shows whether the derricking gear of the lattice extension is switched on or off.

Indicator lamp is dimly lit:	Derricking gear is switched off
Indicator lamp is brightly lit:	Derricking gear is switched on

After switching on the ignition, the derricking gear of the lattice extension is off and the indicator lamp in the rocker button is dimly lit.



To switch on derricking gear: Indicator lamp is dimly lit.
Press rocker button upwards once; the indicator lamp will then be brightly lit.

If the control lever is assigned more than one function, all other power units which are assigned the same movement of the control lever are switched off. Indicator lamps in the corresponding rocker buttons are dimly lit.

To switch off derricking gear: Indicator lamp is brightly lit.
Press rocker button upwards once; the indicator lamp will then be dimly lit.

If the control lever is assigned more than one function, the derricking gear can also be switched off by switching on a power unit which is assigned the same movement of the control lever.

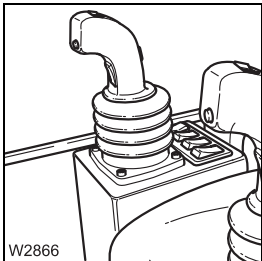

If the derricking gear of the lattice extension is switched on, the lattice extension is lowered with the right-hand control lever.

To raise the lattice extension: Move the control lever to the left

To lower the lattice extension: Move the control lever to the right

On the crane control display

Various indicators and adjustment capabilities become active on the hydraulically derricked lattice extension. For calling up menus and for setting *Operating instructions GMK 5220 – Part 2 Crane operation.*



If the electrical connection between the main boom and the lattice extension is disconnected, the symbol for the lattice extension will be shown in grey on grey in both of the following submenus.

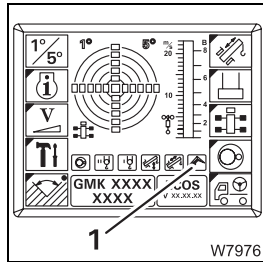

Indicator lamp *Derricking lattice extension on/off* (1) is displayed in the main menu. The indicator lamp shows whether the derricking gear of the lattice extension is switched on or off.

Lights up green: Derricking gear of the lattice extension is switched on

Lights up red: Derricking gear of the lattice extension is switched off

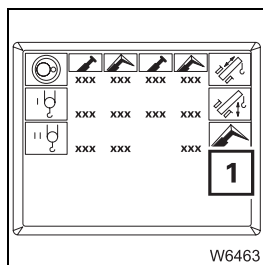

In the *Power unit speed* sub-menu, the symbol (1) for lattice extension operation is shown in **black** and the maximum speed for lowering the lattice extension can be entered in addition to the other power units.

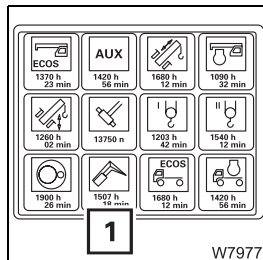

In the *Operating hours counter* sub-menu, the value in the display under the symbol for the lattice extension (1) increases by the time in which the lattice extension is derricked.

On the safe load indicator

Enter the SLI code on the SLI for operation with the lattice extension according to the load capacity chart, as described in the *Operating instructions GMK 5220.*

Enter the components of the lattice extension as described below.



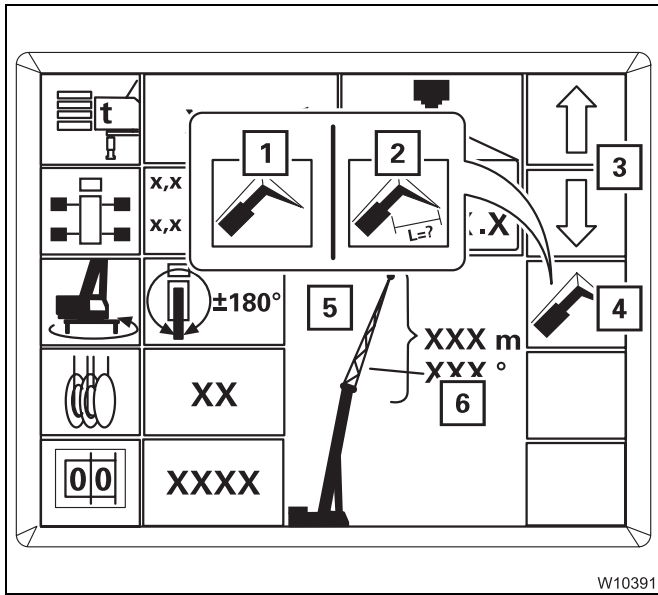

- Boom system

- Press the button (4) repeatedly until the symbol for the required input is **green**.
 - 1 Boom system input
 - 2 Lattice extension length/angle input
- Press the button (3) repeatedly until
 - the display (5) shows the rigged boom system, e.g. the lattice extension 1 or
 - until the display (6) shows the rigged lattice extension length, and in the case of an inclinable lattice extension, the rigged lattice extension angle.

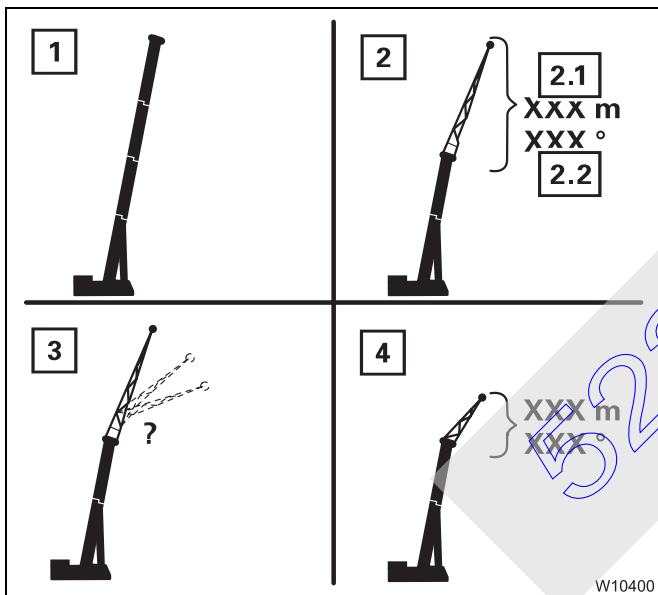

The displays are different for the different boom systems:

- 1 Main boom/auxiliary single-sheave boom top
 - 2 Lattice extension
 - 2.1 Length
 - 2.2 Angle¹⁾
 - 3 Enter SLI rigging code for angling¹⁾
 - 4 Heavy load lattice extension
- 1) Inclinable lattice extension

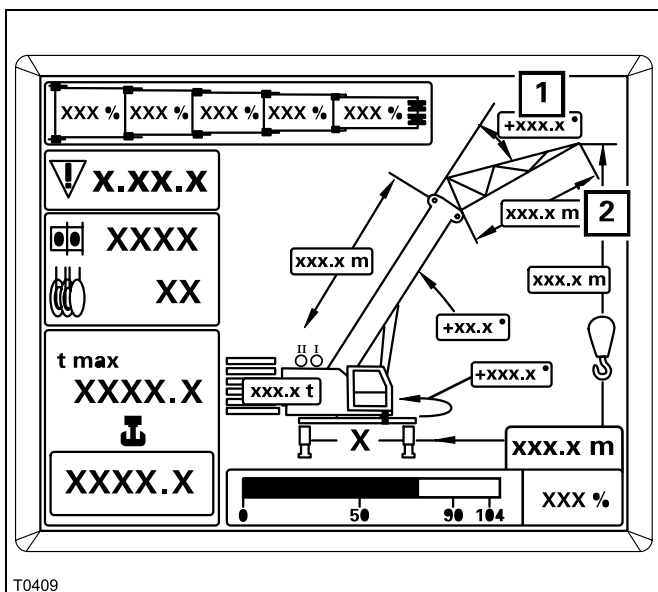

In the Monitoring sub-menu, the following are shown for the lattice extension:

- 1 The current angle of the lattice extension (inclinable)
- 2 The length of the rigged lattice extension

3.1.2

Operating and display elements on the hand-held control

Connection options for hand-held control;  *With the hand-held control*, p. 3 - 91.

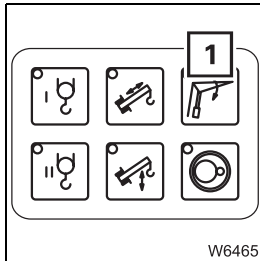

If a hydraulically derricked lattice extension is electrically connected, the *Derrick lattice extension* (1) pre-selection button will become active.

The button is pressed once to preselect the *Derrick lattice extension* function. When the crane control system releases the function, the indicator lamp in the button lights up and the released function can be executed with the buttons on the two-hand operating panel.

Two buttons must always be pressed in order to move the preselected function. There are two possible combinations. Buttons that have been pressed are shown in black in the illustrations:

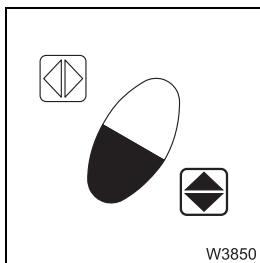

To raise the lattice extension: Press the direction button  and also press the *Left/down* movement button

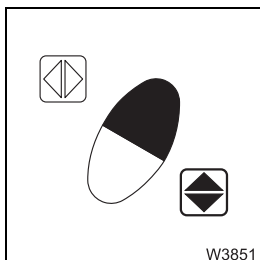

To lower the lattice extension: Press the direction button  and also press the *Right/up* movement button

The lattice extension is lowered or raised as long as the buttons are pressed or until the end position or a switch-off point is reached.

Horn button

The horn button (1) is used to activate the horn of the superstructure if the hand-held control is connected to the socket on the superstructure.

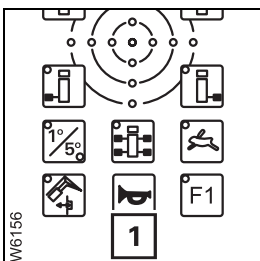

3.1.3

Operating and display instruments on the swing-away lattice extension

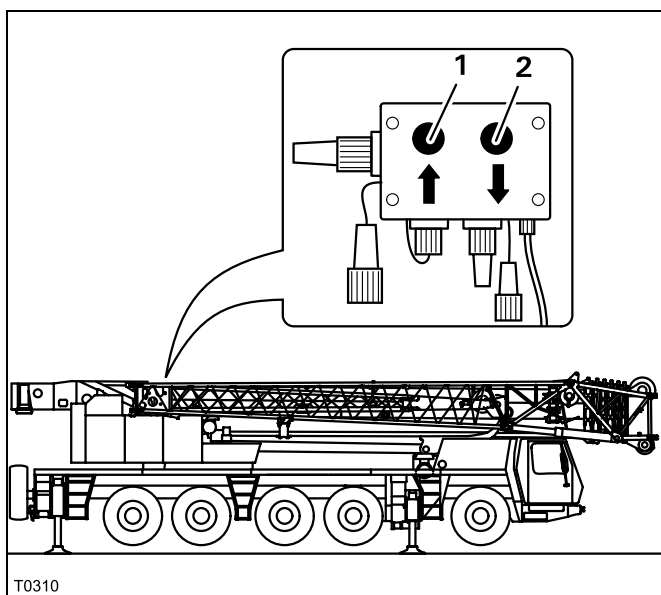

There is a button unit with two buttons on the front of section 1.

- 1 "Raise lattice extension" push-button
- 2 "Lower lattice extension" push-button

The swing-away lattice extension is lowered or raised as long as the push-button is pressed or until the end position or a switch-off point is reached.

52203182

3.2

Identification of the swing-away lattice extension

The swing-away lattice extension is designed for the truck crane with which it was delivered. The sections of the swing-away lattice extension belonging to the truck crane have the same serial number as the truck crane.

The following sections are identified by the serial number:

- Section 1 (12 m (39 ft)) on the fixed section,
- Section 1 (12 m (39 ft)) on the inclinable section,
- Section 2 (9 m (30 ft)).



Risk of accidents during operation with non-modified swing-away lattice extension

Only operate the truck crane with those sections of the swing-away lattice extension which have the same serial number as the crane.

The SLI is set only for this swing-away lattice extension.

This prevents malfunctions and damage.



For technical reasons a truck crane may only be set with one swing-away lattice extension.

If you wish to use the swing-away lattice extension on several GROVE truck cranes, the swing-away lattice extension sections must be adjusted for the corresponding cranes and labelled with all of the respective serial numbers.



Risk of accidents if not adjusted correctly

The adjustment of the swing-away lattice extension may only be carried out by *CraneCARE*.



**Serial number
on section 1**

Section 1 consists of a fixed section and an inclinable section.

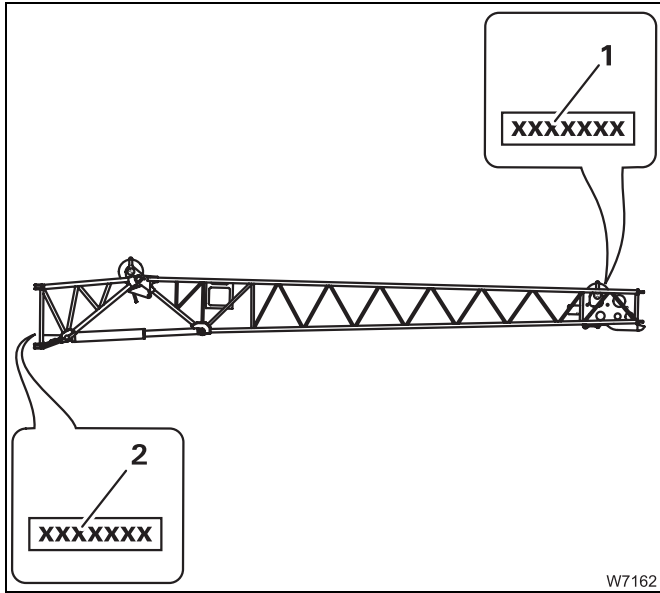

On the inclinable section the serial number (1) is at the front on a plate to the right of the deflection sheave.

The serial number (2) is at the rear left-hand side of the fixed section, on the lower plate.

**Serial number
on section 2**

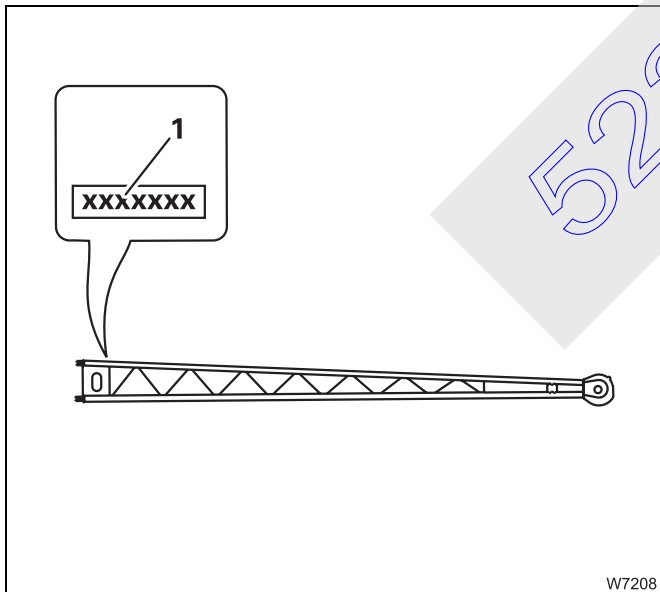

On section 2 the serial number (1) is at the rear on the plate in the top chord.

52203182

3.3

Composition of the swing-away lattice extension

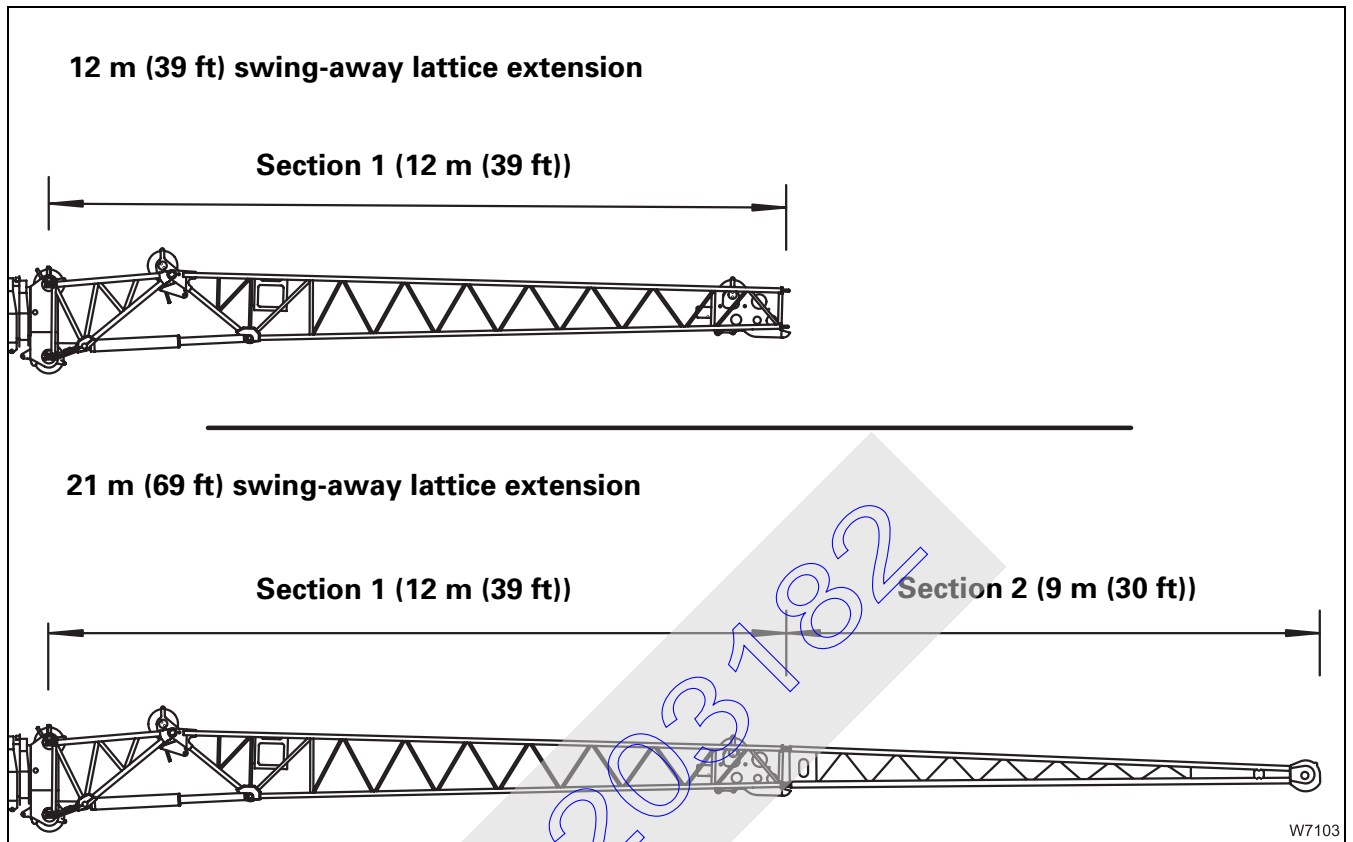

The length data for the swing-away lattice extension of 12 m (39 ft) and 21 m (69 ft) corresponds to the distance between the centre of the locking pin (on the main boom head) and the front edge of the head sheave. That is why the length data of the components in the *Transport dimensions and weights* section and their sums do not correspond to the specified lattice extension lengths; ■■■► p. 2 - 1.



The *Lifting capacity tables* primarily contain the term *Swing-away lattice extension*. This term will only be used later in this chapter, when a length specification is necessary. When no length data is necessary (e.g. for rigging work), the term *Lattice extension* is only used when the text needs to be as short as possible.

3.4

Centres of gravity for slinging

When you sling the lattice extension or an component, then you have to observe the different centres of gravity so that the sections hang horizontally.



Risk of accidents due to falling lattice extension sections

Always observe relevant centres of gravity shown in following table when slinging and use suitable slinging material with sufficient load bearing capacity; *Transport dimensions and weights*, p. 2 - 1.

In this way you prevent the attached sections from slipping out, falling and causing injury during installation or removal.

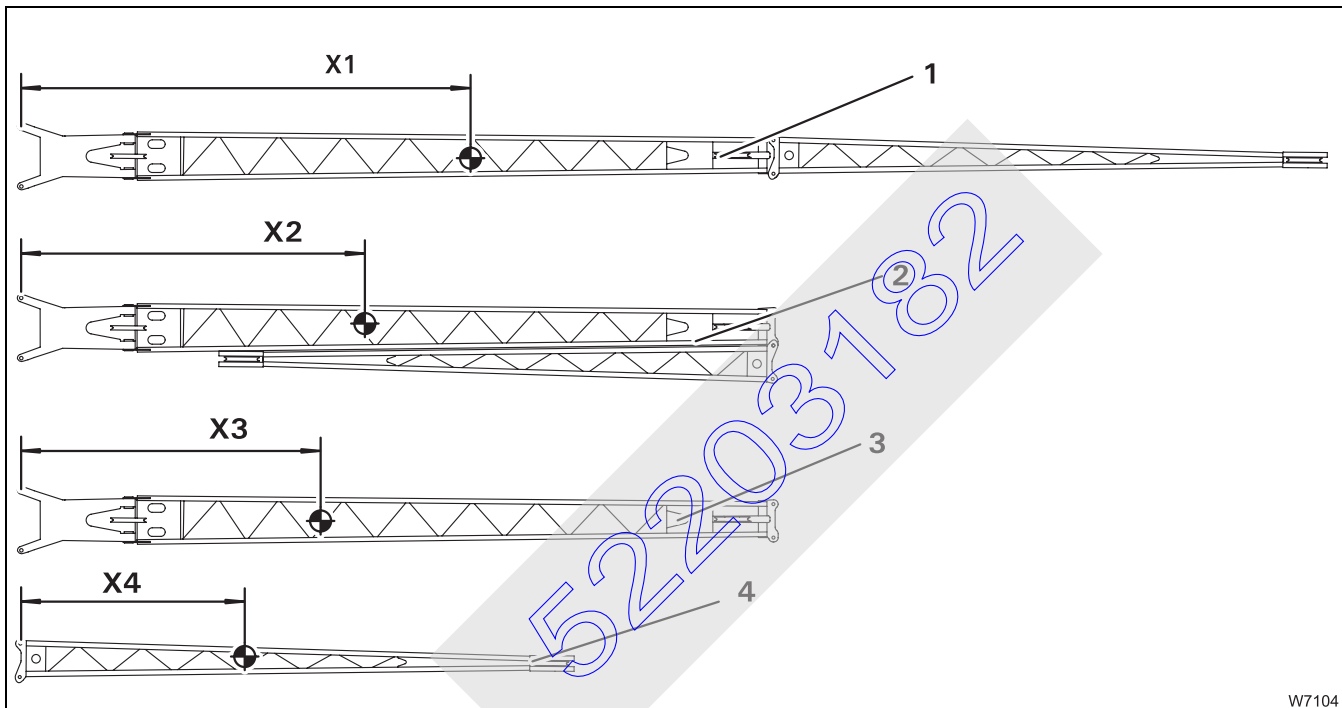

W7104



All distances (X_1) to (X_4) are measured from the centre of the fork elements and apply to the hydraulically derricked lattice extension and to the manually inclinable lattice extension.

No.	Description	Status	Distance X in mm (in)	
1	21 m (69 ft) swing-away lattice extension	Section 2 before section 1	$X_1 =$	7 650 (301.4)
2	21 m (69 ft) swing-away lattice extension	Section 2 on section 1	$X_2 =$	6 270 (247.0)
3	Section 1	alone	$X_3 =$	4 830 (190.3)
4	Section 2	alone	$X_4 =$	4 040 (159.2)

3.5

Checklists for rigging work





3.5.1

Overview of the required rigging work

There are different initial states for rigging the lattice extension, depending on whether

- the lattice extension is folded at the side of the main boom or
- the lattice extension was removed for on-road driving (information about the driving modes;  *Operating instructions GMK 5220 – Driving modes*).

The following table shows you which checklist describes the required rigging work for your initial state.

	Initial state	Corresponding rigging work
Before crane operation	The lattice extension is on the side of the main boom.	 Checklist for rigging; p. 3 - 19
	The lattice extension was removed completely.	 Checklist for installation; p. 3 - 12
After crane operation	The lattice extension must be folded onto the side of the main boom.	 Checklist for unrigging; p. 3 - 25
	The lattice extension is to be removed for on-road driving.	 Checklist for removal; p. 3 - 14

3.5.2

CHECKLIST: Installing the 12/21 m (39/69 ft) swing-away lattice extension



This checklist is not equivalent to complete operating instructions. There are accompanying instructions which are indicated by cross-references. **Observe the warning and safety information given there.**

Prerequisites:

- The truck crane is on outriggers or the main boom has been placed on the boom rest.
- An auxiliary crane is available.

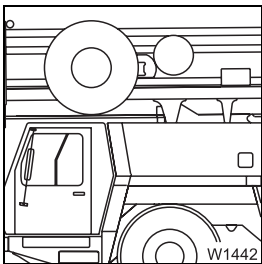

1. Put the hydraulic hoses into the correct position for working with the lattice extension, or install the hose drum if necessary:
 - Installing the hose drum; p. 3 - 41.
 - Releasing locking device on the hose drum, p. 3 - 38.
 - Positioning hydraulic hoses for working with the lattice extension; p. 3 - 40.

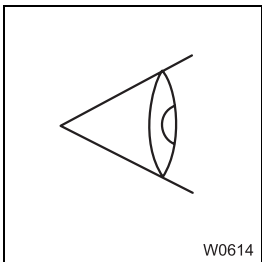

2. Check the transport condition of the swing-away lattice extension; *Transport condition with removed lattice extension*, p. 3 - 37.

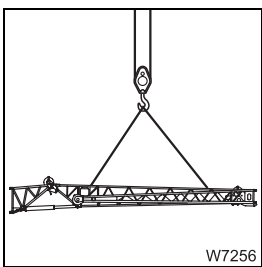

3. Sling the lattice extension on auxiliary crane and fasten the guide ropes; *Centres of gravity for slinging*, p. 3 - 10.

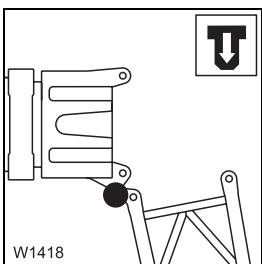

4. Lift the lattice extension with the auxiliary crane in front of the main boom and create a slewing connection between section 1 and the main boom; *Connecting/disconnecting the slewing connection*, p. 3 - 58.



Danger of becoming trapped due to swinging lattice extension.

Always secure the lattice extension against swinging with the auxiliary crane and the guide ropes before you establish the hydraulic or electrical connection.

This will prevent the lattice extension from swinging inadvertently to the side of the main boom and possibly crushing you.

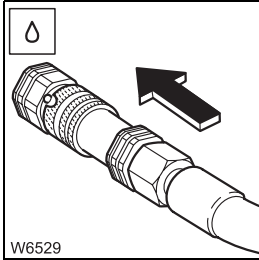

5. Establish hydraulic connection between the lattice extension and the main boom; **|||▶** *Establishing the hydraulic connection, p. 3 - 43.*

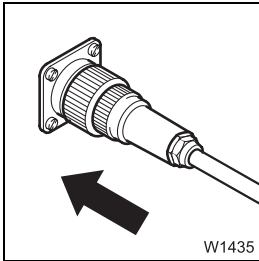

6. Establish electrical connection between section 1 and the main boom; **|||▶** *Establishing an electrical connection, p. 3 - 74.*

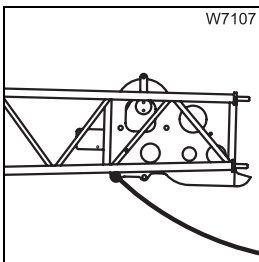

7. Fasten the guide ropes to the front of section 1.



If the lattice extension needs to be rigged in front of the main boom, proceed as from point 9.

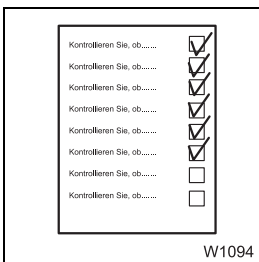

8. The *CHECKLIST: Unrigging the 12/21 m (39/69 ft) swing-away lattice extension* from Point 19. **|||▶** p. 3 - 28 describes further rigging work dealing with lateral folding.

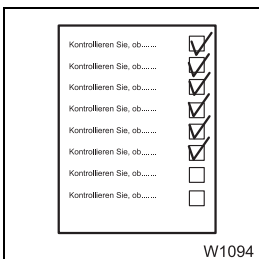

9. Further rigging work for the 12 m (39 ft) swing-away lattice extension or the 21 m (69 ft) swing-away lattice extension is described in the *CHECKLIST: Rigging the 12/21 m (39/69 ft) swing-away lattice extension* from Point 15.; **|||▶** p. 3 - 21.

08.09.2006

3.5.3

CHECKLIST: Removing the 12/21 m (39/69 ft) swing-away lattice extension



This checklist is not equivalent to complete operating instructions. There are accompanying instructions which are indicated by cross-references. **Observe the warning and safety information given there.**

Prerequisites:

- The truck crane is on outriggers or the main boom has been placed on the boom rest.
- An auxiliary crane is available.

For a rigged lattice extension

This checklist only applies when the lattice extension is rigged. If the lattice extension is folded up at the side of the main boom, another checklist applies; p. 3 - 16.



If you want to transport the lattice extension while it is folded, but only section 1 is swung out and section 2 is locked to the main boom, you should first unrig the lattice extension (p. 3 - 16) and then remove it (p. 3 - 16).

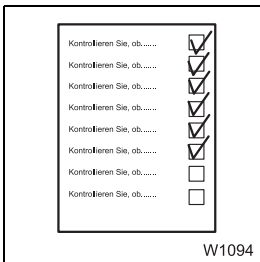

1. Carry out all rigging work contained in the *CHECKLIST: Unrigging the 12/21 m (39/69 ft) swing-away lattice extension* up to and including point 16.; p. 3 - 27.

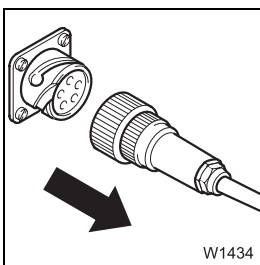

2. Disconnect electrical connection between section 1 and the main boom; *Disconnecting the electrical connection*, p. 3 - 75.

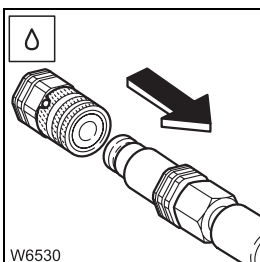

3. Disconnect hydraulic connection between the lattice extension and the main boom; *Breaking the hydraulic connection*, p. 3 - 43.

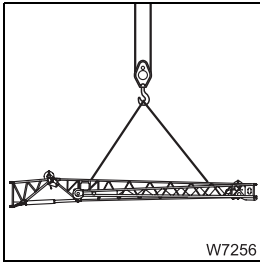

4. Slings the lattice extension to the auxiliary crane; Centres of gravity for slinging, p. 3 - 10.

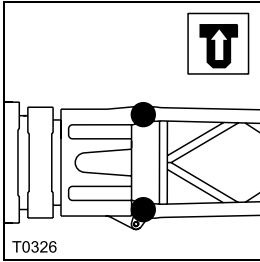

5. Remove the connection on the right and left between the main boom and section 1; Connections on the left and right of the main boom head, p. 3 - 60.

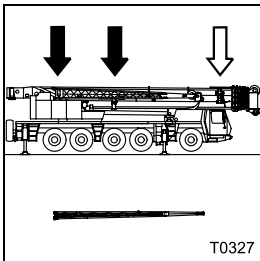

6. If section 2 is still installed on the main boom and is also to be removed:
– Sling section 2, centre of gravity; p. 3 - 10.
– Disconnect the connection between section 2 and the main boom in the *Middle* area; p. 3 - 52.
– Disconnect the connection between section 2 and the main boom in the *Rear* area; p. 3 - 54.
– Set down section 2 onto the separate vehicle.

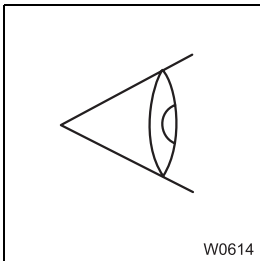

7. Check the transport condition of the swing-away lattice extension; Transport condition with removed lattice extension, p. 3 - 37.

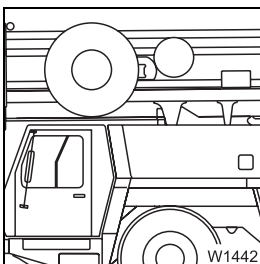

8. Put the hydraulic hoses into the correct position for working with the main boom, or remove the hose drum if necessary:
– Positioning hydraulic hoses for working with the main boom; p. 3 - 40.
– Inserting locking device on the hose drum; p. 3 - 39.
– Removing the hose drum; p. 3 - 42.

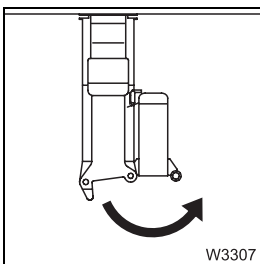



9. If necessary, fold in the run-up rail; p. 3 - 45.



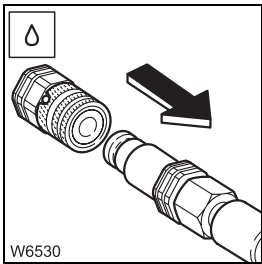

For a folded lattice extension

This checklist only applies when the lattice extension is folded at the side of the main boom. When the lattice extension is rigged, another checklist applies;  p. 3 - 14.

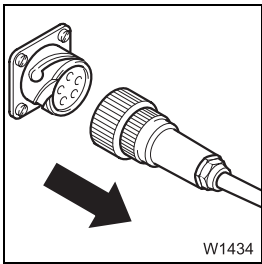

1. Disconnect hydraulic connection between the lattice extension and the main boom;  *Breaking the hydraulic connection*, p. 3 - 43.



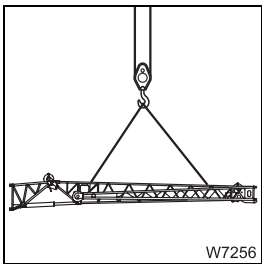

2. If necessary, disconnect electrical connection between section 1 and the main boom;  *Disconnecting the electrical connection*, p. 3 - 75.



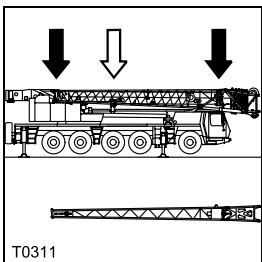

3. Sling the lattice extension on auxiliary crane and fasten a guide rope;  *Centres of gravity for slinging*, p. 3 - 10.

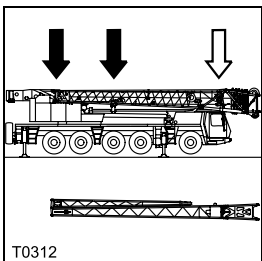

4. When the 12 m (39 ft) swing-away lattice extension is folded to the side:
 - Disconnect the connection between section 1 and the main boom in the *Rear* area;  p. 3 - 56.
 - Disconnect the connection between section 1 and the main boom in the *Front* area;  p. 3 - 48.



5. When the 21 m (69 ft) swing-away lattice extension is folded to the side:
 - Check if the connection between section 1 and section 2 is established in the *Rear* area;  p. 3 - 56.
 - Check that the connection in the *Middle* area is in the position *Section 1/Section 2*;  p. 3 - 51.

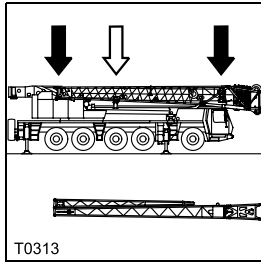

6. When the **21 m (69 ft)** swing-away lattice extension is folded to the side:
- Disconnect the connection between section 2 and the main boom in the *Rear* area; ||||▶ p. 3 - 54.
 - Release the connection in the *Front* area; ||||▶ p. 3 - 48.

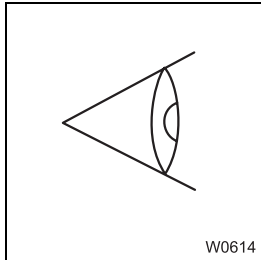

7. Check the transport condition of the swing-away lattice extension; ||||▶ *Transport condition with removed lattice extension*, p. 3 - 37.

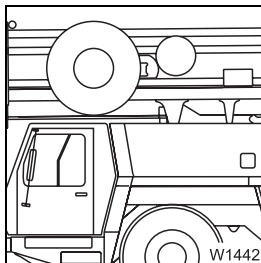

8. Put the hydraulic hoses into the correct position for working with the main boom, or remove the hose drum if necessary:
- Positioning hydraulic hoses for working with the main boom; ||||▶ p. 3 - 40.
 - Inserting locking device on the hose drum, ||||▶ p. 3 - 39.
 - Removing the hose drum; ||||▶ p. 3 - 42.

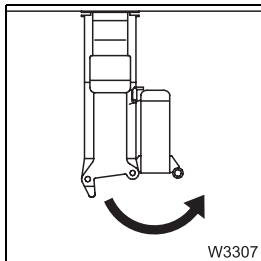

9. If necessary, fold in the run-up rail; ||||▶ p. 3 - 45.

Blank page

52203182

3.5.4

CHECKLIST: Rigging the 12/21 m (39/69 ft) swing-away lattice extension



This checklist is not a complete set of operating instructions. There are accompanying operating instructions which are referred to by cross-references. **Observe the warnings and safety instructions there.**

1. Prepare the truck crane for rigging the swing-away lattice extension;
 ▮▮▮▮ *Prerequisites for rigging*, p. 3 - 31.

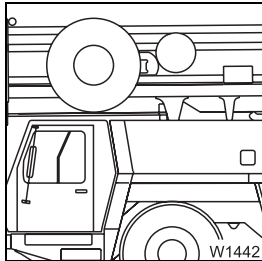

2. Put the hydraulic hoses into the correct position for working with the lattice extension, or install the hose drum if necessary:
 - Installing the hose drum; ▮▮▮▮ p. 3 - 41.
 - Releasing locking device on the hose drum, ▮▮▮▮ p. 3 - 38.
 - Positioning hydraulic hoses for working with the lattice extension; ▮▮▮▮ p. 3 - 40.

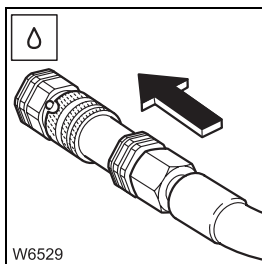

3. Establish a hydraulic connection between section 1 and the main boom; ▮▮▮▮ *Establishing the hydraulic connection*, p. 3 - 43.

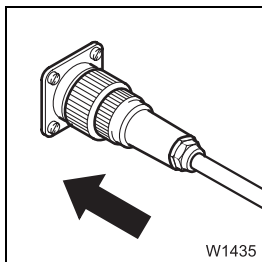

4. Establish an electrical connection between section 1 and the main boom; ▮▮▮▮ *Establishing an electrical connection*, p. 3 - 74.

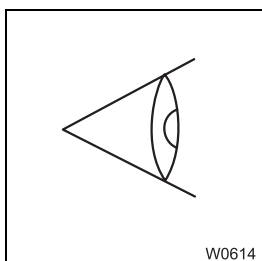

5. Check if the lattice extension was unrigged properly and is in transport condition; ▮▮▮▮ *Transport condition with lattice extension folded at the side*, p. 3 - 34.



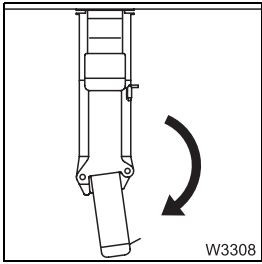

6. Fold out the run-up rail; p. 3 - 45.

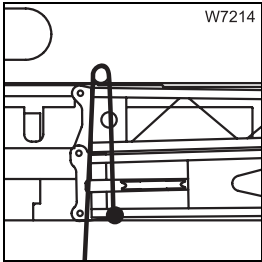

7. Secure the lattice extension on the main boom with guide rope;
 Securing the lattice extension with rope, p. 3 - 32.

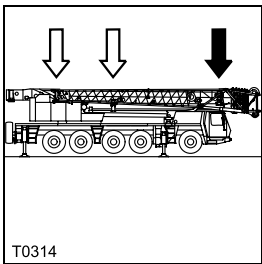

8. Check if the connection is made in the *Front* area.
The slewing axis must jut out from the top of the clamp on section 1 and must be secured against retraction with the pin; *Establishing a connection*, p. 3 - 47.

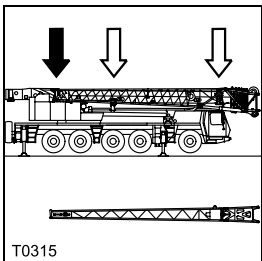

9. This point only applies to the rigging of the **12 m (39 ft)** swing-away lattice extension, when only **section 1** is installed.
Release the connection between section 1 and the main boom in the *rear* area; p. 3 - 56.

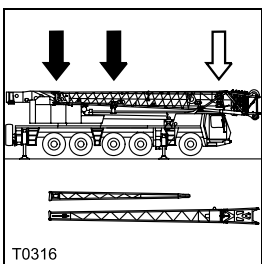

10. This point only applies to the rigging of the **12 m (39 ft)** swing-away lattice extension, when **section 2** is also installed.

- Move the connection in the *Middle* area into the position *section 2/ main boom*; p. 3 - 52.
- Release the connection between section 2 and the main boom in the *rear* area; p. 3 - 54.
- Disconnect the connection between section 2 and section 1 in the *Rear* area; p. 3 - 57.

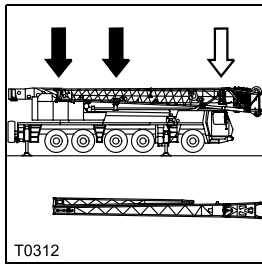

- 11.** This point only applies when rigging the **21 m (69 ft)** swing-away lattice extension.
- Check that the connection in the *middle* area is in the position *section 1/section 2*; ■■■▶ p. 3 - 51.
 - Check if the connection between section 1 and section 2 is established in the *rear* area; ■■■▶ p. 3 - 57.
 - Release the connection between section 2 and the main boom in the *rear* area; ■■■▶ p. 3 - 54.

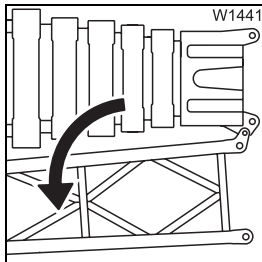

- 12.** Swinging the lattice extension onto the main boom head; ■■■▶ p. 3 - 64.

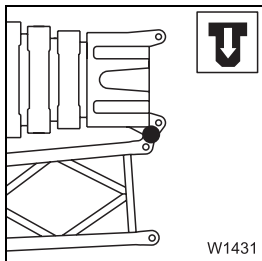

- 13.** Establish a slewing connection between section 1 and the main boom head; ■■■▶ *Connecting/disconnecting the slewing connection*, p. 3 - 58.

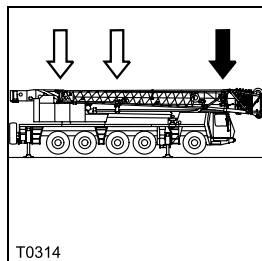

- 14.** Release the connection in the *Front* area; in addition, retract the slewing axle mechanically, if necessary; ■■■▶ *Releasing the connection*, p. 3 - 48.

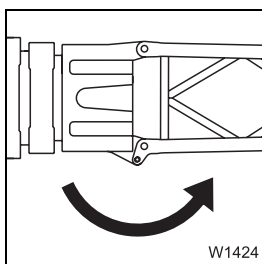

- 15.** Swing the lattice extension in front of the main boom head; ■■■▶ *When rigging – section 1*, p. 3 - 65.

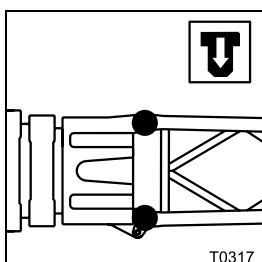

- 16.** Pin section 1 onto the main boom head, on the left and right-hand side; release the bearing points if necessary;
- ▶ *Establishing connections*, p. 3 - 60,
 - ▶ *Relieving the connecting points*, p. 3 - 63.



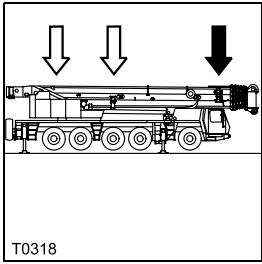

17. In the *front* area, move the connection into the *unrigging* position;
 ■■■► *Moving the Front connection into the Unrigging position, p. 3 - 50.*



When the **12 m (39 ft)** swing-away lattice extension is rigged – proceed as from **point 24.**; ■■■► p. 3 - 23.

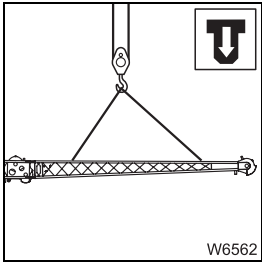

18. If section 2 was transported on a separate vehicle, install section 2 before section 1:
 – Sling section 2 onto the auxiliary crane, centre of gravity; ■■■► p. 3 - 10.
 – Lift section 2 in front of section 1 and pin it there; ■■■► p. 3 - 72.

After installing section 2, proceed as from **point 24.**

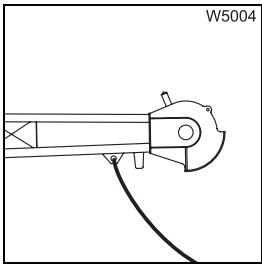

19. When section 2 is folded on the side of section 1, fasten the guide rope to the head of section 2.

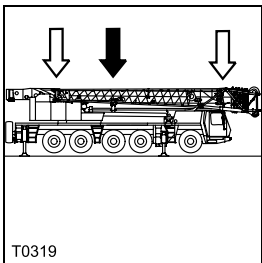

20. Move the connection in the *middle* area into the position *section 1/main boom*; ■■■► p. 3 - 52.

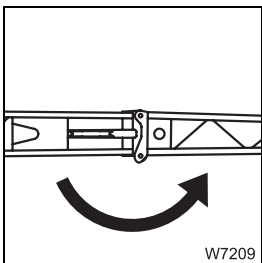

21. Swing section 2 in front of section 1; ■■■► *When rigging – section 2, p. 3 - 67.*

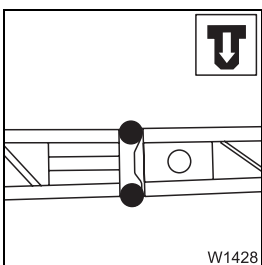

22. Establish the connection on the left between section 2 and section 1;
 ■■■► p. 3 - 70.

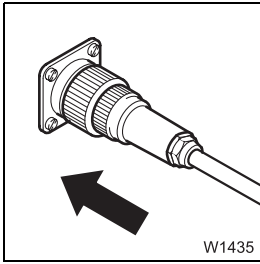

- 23.** Establish electrical connection between section 1 and section 2;  *Establishing the electrical connection, p. 3 - 76.*

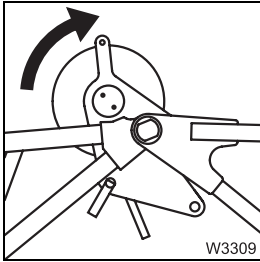

- 24.** Fold out both deflection sheaves on section 1;  *Folding out the deflection sheaves, p. 3 - 77.*

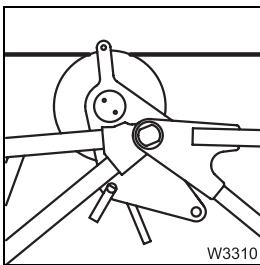

- 25.** Position the hoist rope on the lattice extension;  *Positioning/removing the hoist rope, p. 3 - 80.*

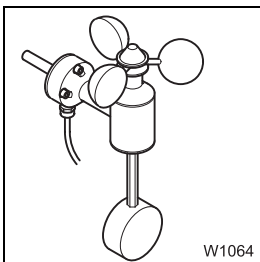

- 26.** Install the anemometer;  *Installing/removing the anemometer, p. 3 - 85.*

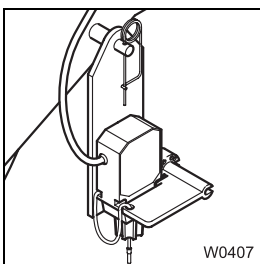

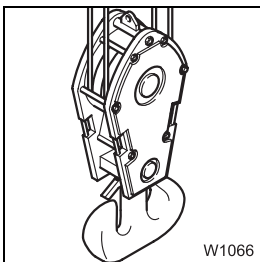

- 27.** Install the lifting limit switch;  *Installing/removing the lifting limit switch, p. 3 - 82.*



- 28.** Reeve the hoist rope;  *Possible reeving methods on the lattice extension, p. 3 - 81.*

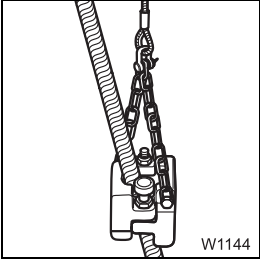



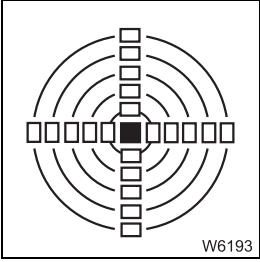

- 29.** Attach the lifting limit switch weight and place it around the hoist rope;  *Operating instructions GMK 5220, Part 2 Superstructure – Rigging work.*

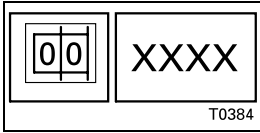

- 30.** Check the alignment of the truck crane and, if necessary, position the truck crane so that it is level.



- 31.** Enter SLI code according to the *lifting capacity table* for the actual rigging status of the truck crane with the rigged lattice extension;  *Setting*, p. 3 - 96.

Further working steps:

- Raise the boom;  p. 3 - 98.
- Telescope with the rigged lattice extension;  p. 3 - 99.

52203182

3.5.5

CHECKLIST: Unrigging the 12/21 m (39/69 ft) swing-away lattice extension



This checklist is not a complete set of operating instructions. There are accompanying operating instructions which are referred to by cross-references. **Observe the warnings and safety instructions there.**

1. Prepare the truck crane for unrigging; *Prerequisites for unrigging*, p. 3 - 31.

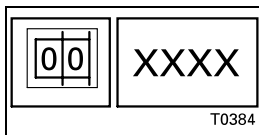

2. Enter SLI code according to the *lifting capacity table* for the actual rigging status of the truck crane with the rigged lattice extension; *Setting*, p. 3 - 96.

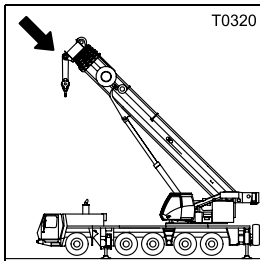

3. Retract the main boom completely; *Telescoping with rigged lattice extension*, p. 3 - 99.

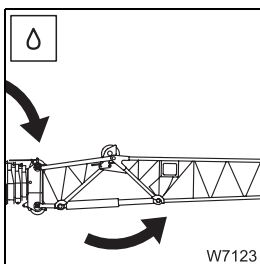

4. This point only applies for the hydraulically derricked lattice extension.
 - Completely retract the lattice extension; *Derricking the lattice extension*, p. 3 - 91.
 - Lower the boom to the horizontal position; p. 3 - 99.

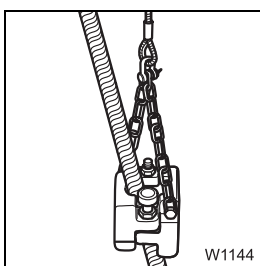

5. Remove the lifting limit switch weight and remove the lifting limit switch; *Installing/removing the lifting limit switch*, p. 3 - 82.

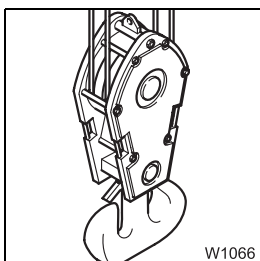

6. Unreeve the hoist rope from the hook block and remove it from the lattice extension; *Positioning/removing the hoist rope*, p. 3 - 80.



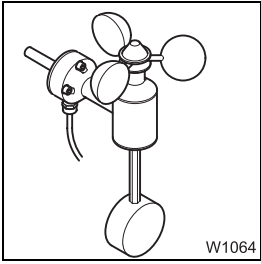

7. Remove the anemometer; *Installing/removing the anemometer, p. 3 - 85.*

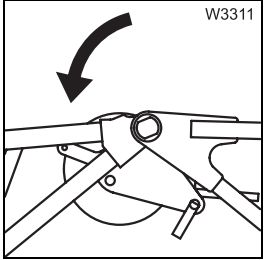

8. Fold in both deflection sheaves on section 1; *Folding in the deflection sheaves, p. 3 - 79.*

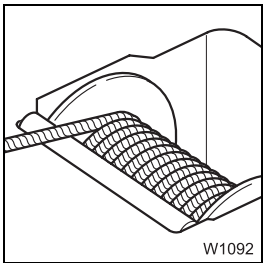

9. Remove the hoist rope and reel it up to the main boom head; *Positioning/removing the hoist rope, p. 3 - 80.*



When the **12 m (39 ft)** swing-away lattice extension is unrigged – proceed as from **point 15.**; p. 3 - 27.

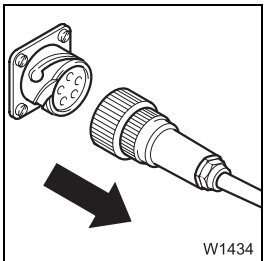

10. Disconnect the electrical connection between section 1 and section 2; *Disconnecting the electrical connection, p. 3 - 76.*

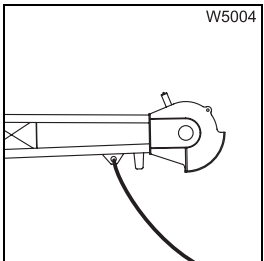

11. Fasten the guide ropes to the front of section 2.

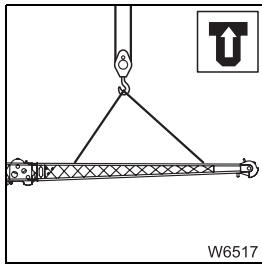

12. If section 2 is to be removed:

- Sling section 2 onto the auxiliary crane, centre of gravity;
 ▶▶▶▶▶ p. 3 - 10.
- Remove the locking pins between section 2 and section 1;
 ▶▶▶▶▶ p. 3 - 69.
- Set down section 2 on the separate vehicle.

After removing section 2, proceed as from **point 15**.

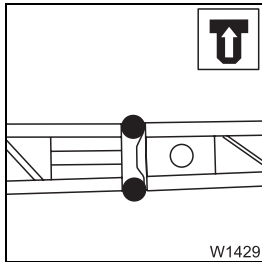

13. Release the connection between section 2 and section 1; ▶▶▶▶▶ p. 3 - 71.

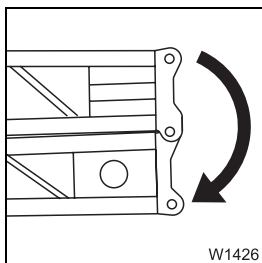

14. Swing section 2 to the side of section 1 and move the connection in the middle area into the position section 1/section 2;

- ▶▶▶▶▶ When unrigging – section 2, p. 3 - 68
- ▶▶▶▶▶ Position Section 1/section 2, p. 3 - 51.

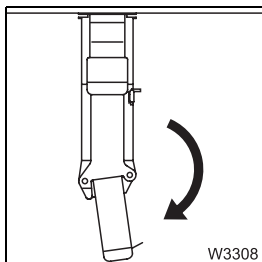

15. Fold out the run-up rail; ▶▶▶▶▶ p. 3 - 45.

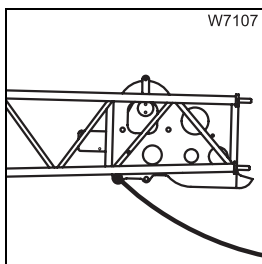

16. Fasten the guide ropes to the front of section 1.

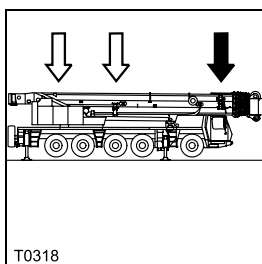

17. In the front area, move the connection into the unrigging position; ▶▶▶▶▶ p. 3 - 50.



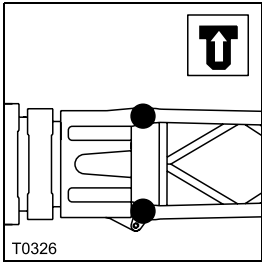

18. Release the connection between section 1 and the main boom head at the left and right of the main boom head; ■■■► *Releasing connections*, p. 3 - 61.

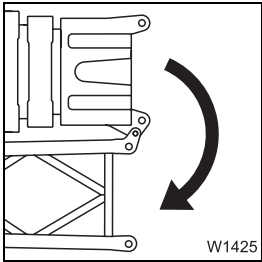

19. Swing the lattice extension onto the side onto the main boom with the guide rope; ■■■► *Only section 1 installed*, p. 3 - 72.

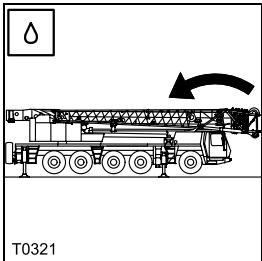

20. Lower the lattice extension so that it is positioned on the run-up rail.

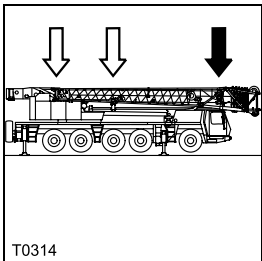

21. Establish the connection in the front area; ■■■► *Establishing a connection*, p. 3 - 47.

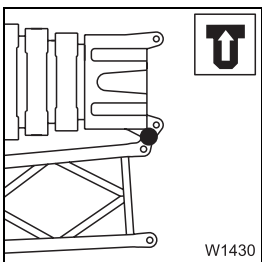

22. Disconnect the slewing connection between section 1 and the main boom head; ■■■► *Connecting/disconnecting the slewing connection*, p. 3 - 58.

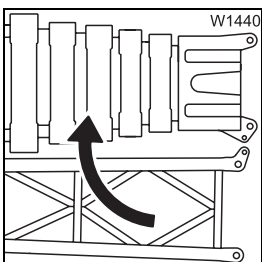

23. Swing the lattice extension to the main boom on the run-up rail ; ■■■► *When unrigging – section 1*, p. 3 - 66.

52203182

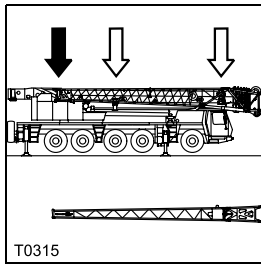

24. This point only applies to the unrigging of the **12 m (39 ft)** swing-away lattice extension, when only **section 1** is installed.
Release the connection between section 1 and the main boom in the *rear* area; p. 3 - 55.

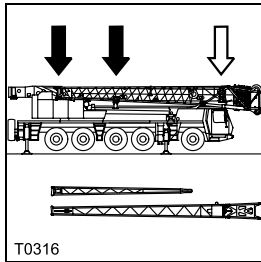

25. This point only applies to the unrigging of the **12 m (39 ft)** swing-away lattice extension, when **section 2** is also installed.
- Establish the connection between section 1 and section 2 in the *middle* area; p. 3 - 51.
 - Establish the connection between section 1 and section 2 in the *rear* area; p. 3 - 57.

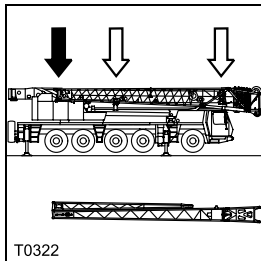

26. This point only applies when unrigging the **21 m (69 ft)** swing-away lattice extension.
- Release the connection between section 2 and the main boom in the *rear* area; p. 3 - 53.

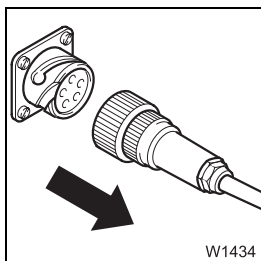

27. Disconnect the electrical connection between section 1 and the main boom; *Disconnecting the electrical connection*, p. 3 - 75.

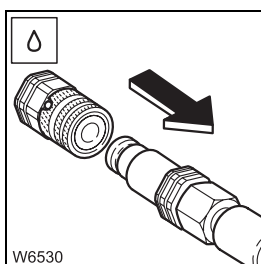

28. Disconnect the hydraulic connection between section 1 and the main boom; *Breaking the hydraulic connection*, p. 3 - 43.

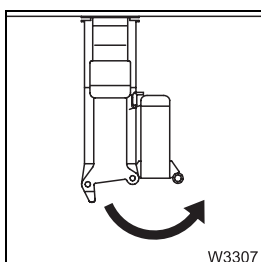

29. Fold in the run-up rail; *Folding the run-up rail out/in*, p. 3 - 45.



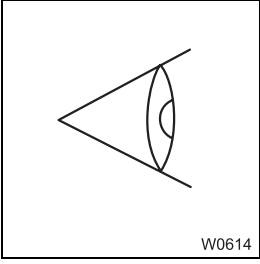

- 30.** Check whether the lattice extension is in transport condition;
▣▣▣▣► For a folded lattice extension, p. 3 - 16.

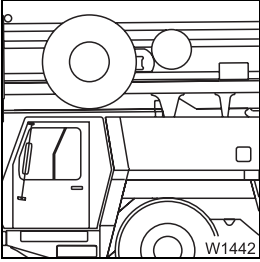

- 31.** Put the hydraulic hoses into the correct position for working with the main boom, or remove the hose drum if necessary:
- Positioning hydraulic hoses for working with the main boom;
▣▣▣▣► p. 3 - 40.
 - Inserting locking device on the hose drum, ▣▣▣▣► p. 3 - 39.
 - Removing the hose drum; ▣▣▣▣► p. 3 - 42.

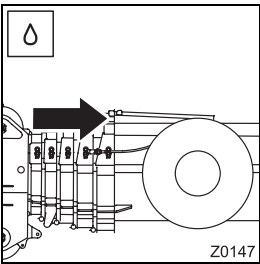

- 32.** If necessary, bring the hydraulic connection of the hose drum into the main boom operation position; ▣▣▣▣► Position for working with the main boom, p. 3 - 40.

52203182

3.6

Description of rigging work

3.6.1

Preparing the truck crane for rigging



The data in this section also applies to the rigging of the boom extension.

Do not override the SLI when lowering into a horizontal position.

If the following prerequisites are met, lowering into the horizontal position with lattice extension/boom extension and a slewing range of 360° is permitted and is monitored by the SLI;  *Raising and setting down the main boom*, p. 3 - 98.

Prerequisites for rigging

Before you rig a lattice extension or the boom extension, the following requirements must be met:

- The lattice extension must be mounted at the side on the main boom and must be in transport condition.
- The counterweight version required according to the *Lifting capacity table* for the planned operation with the lattice extension must be rigged.
- The truck crane must be supported by the outrigger span required acc. to the *Lifting capacity table* for the planned operation with the lattice extension, and must be level.
- The main boom must be completely retracted and have been lowered into horizontal position.
- All telescopic sections must be completely retracted.
- If the truck crane is equipped with two hoists as additional equipment, the hook block is unreeved on the hoist, which is not used for working with the lattice extension.

Prerequisites for unrigging

Before you lower a lattice extension or the boom extension into a horizontal position, the following requirements must be met:

- No other load is raised apart from the hook block.
- The counterweight version required according to the *Lifting capacity table* for the planned operation with the lattice extension must be rigged.
- The truck crane must be supported with the outrigger span prescribed for operation with the rigged lattice extension according to the *Lifting capacity table*.



- All telescopic sections must be completely retracted.
- The SLI code for operation with the rigged lattice extension must have been entered.

Securing the lattice extension with rope

If the truck crane is not well aligned, the lattice extension may swing out of its own accord when you remove the last connection that held the lattice extension at the side of the main boom.

You must therefore secure the lattice extension before you begin with the rigging work.



Risk of accidents from lattice extension swinging of its own accord

Always secure the lattice extension with a guide rope on the main boom before removing any connections.

This will prevent the lattice extension from slipping off the run-up rail, swinging around and knocking you off the carrier or injuring other persons in the slewing range.

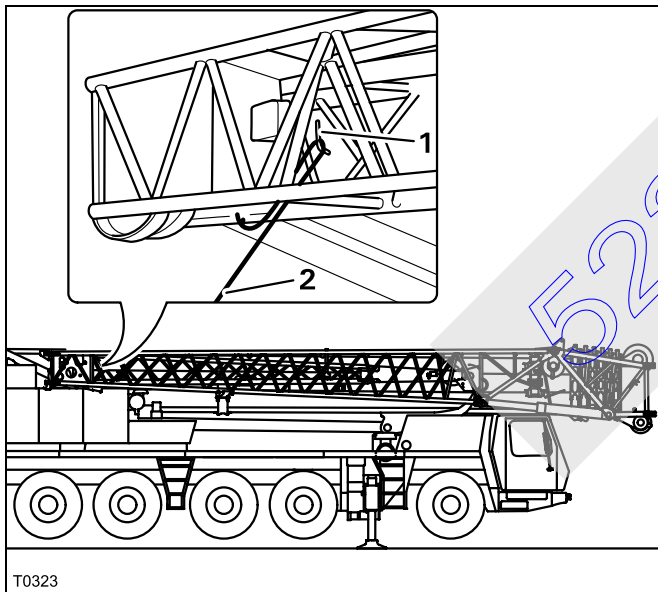

Secure the lattice extension as follows:

- Attach a rope (2) at the front of the lattice extension.
- Guide the rope underneath the lattice extension, via the holding rod (1) on the main boom and back again.
- Have a helper hold the rope tight while you are removing the last connection.



If you are alone, secure the other end of the rope to the crane (e.g. on the steps of the access ladder to the carrier). Leave enough play in the rope so that it is tight only when you swing the lattice extension towards the main boom head later on.

3.6.2

Checking the transport condition

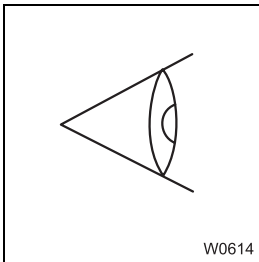

For transportation you must establish certain connections between both sections of the lattice extension. The connections which need to be established depend on whether the lattice extension:

- is folded up at the side of the main boom for transportation or
- is completely removed for transportation.

Transport condition is when the lattice extension has been removed as described in the corresponding checklists.



Risk of damage to the lattice and the main boom

Always put the lattice extension into transport condition before driving the truck crane with a lattice extension folded at the side or working with the main boom.

Only then is the lattice extension secured against slipping.

This way you prevent the partly fastened lattice extension hitting the main boom or the individual components of the lattice extension hitting each other and becoming damaged.

You have to check the transport condition:

- After unrigging the lattice extension, before you drive the truck crane with the lattice extension folded at the side or work with the main boom.
- Before installation and before rigging the lattice extension.
The corresponding checklists require that the lattice extension is in transport condition.

The following paragraphs and the diagram show the necessary connections for the transport condition with the lattice extension folded at the side and removed.



Transport condition with lattice extension folded at the side

The transport condition with the lattice extension folded at the side is created when all of the following connections are established.

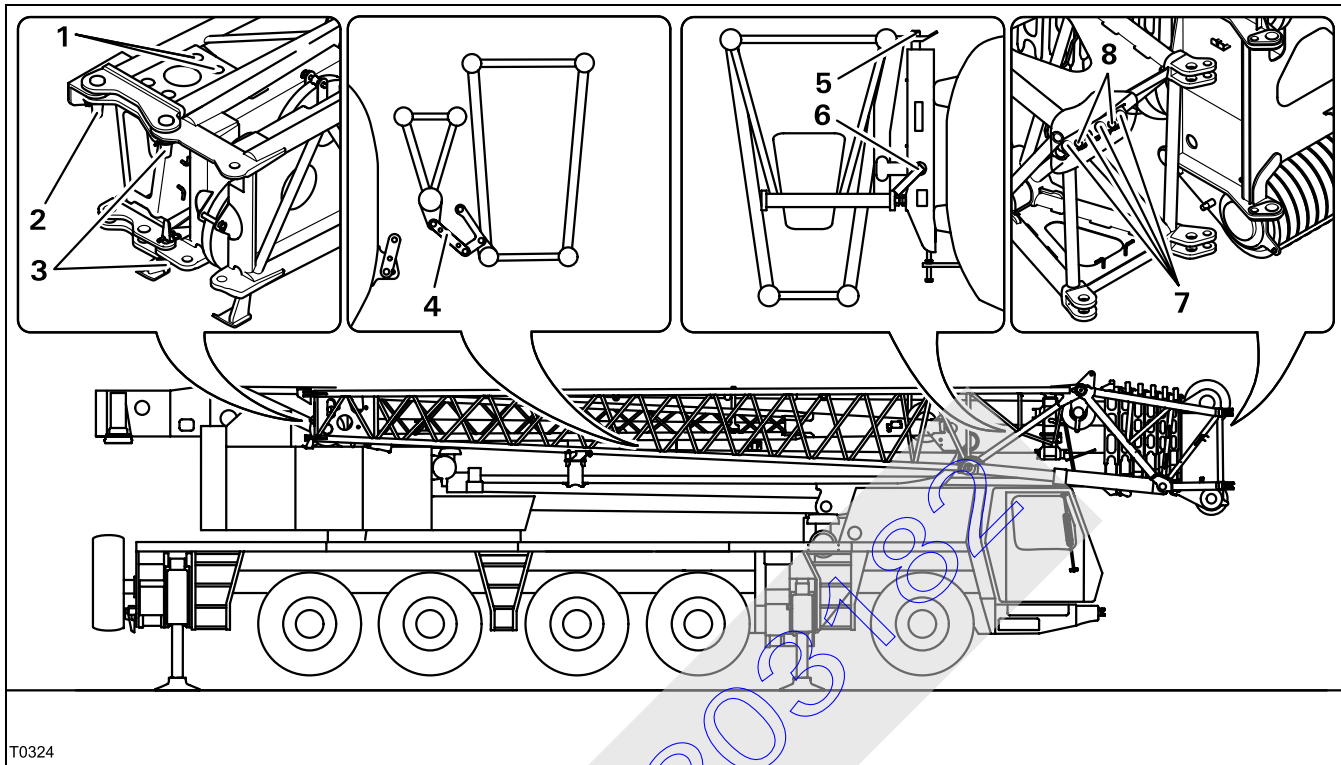

T0324

When section 1 and section 2 are folded to the side

- Check the following connections and establish them if necessary:
 - In the *Front* area, section 1 must be engaged at the slewing axis (5) on the main boom and the slewing axis must be secured with the pin (6); ■■■► *Establishing a connection*, p. 3 - 47.
 - In the *Middle* area, the connection (4) is in the position *Section 1/ Section 2*; ■■■► p. 3 - 51.
 - In the *Rear* area, the connection (2) between section 2 and the main boom is established; ■■■► p. 3 - 53.
 - In the *Rear* area, the connection (3) between section 1 and section 2 is established; ■■■► p. 3 - 57.
The unrequired pins (1) are secured in the retaining sheet.
 - The pins (7) and (8) on section 1 are secured with retaining pins.

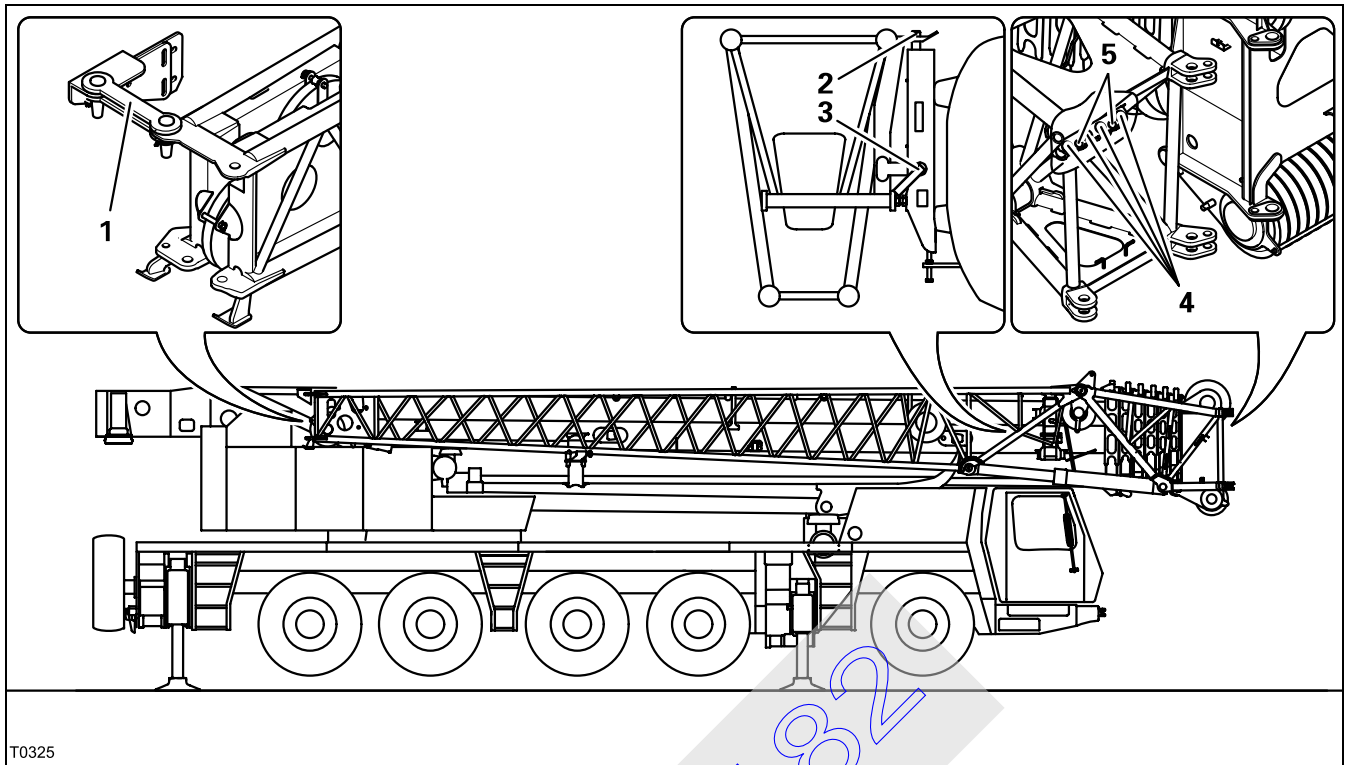

T0325

Only when section 1 is folded to the side:

- Check the following connections and establish them if necessary:
 - In the *Front* area, section 1 must be engaged at the slewing axis (2) on the main boom and the slewing axis must be secured with the pin (3);
▮▮▮▮▮ *Establishing a connection*, p. 3 - 47.
 - In the *Rear* area, the connection (1) between section 1 and the main boom is established; ▮▮▮▮▮ p. 3 - 55.
 - The pins (4) and (5) on section 1 are secured with retaining pins.



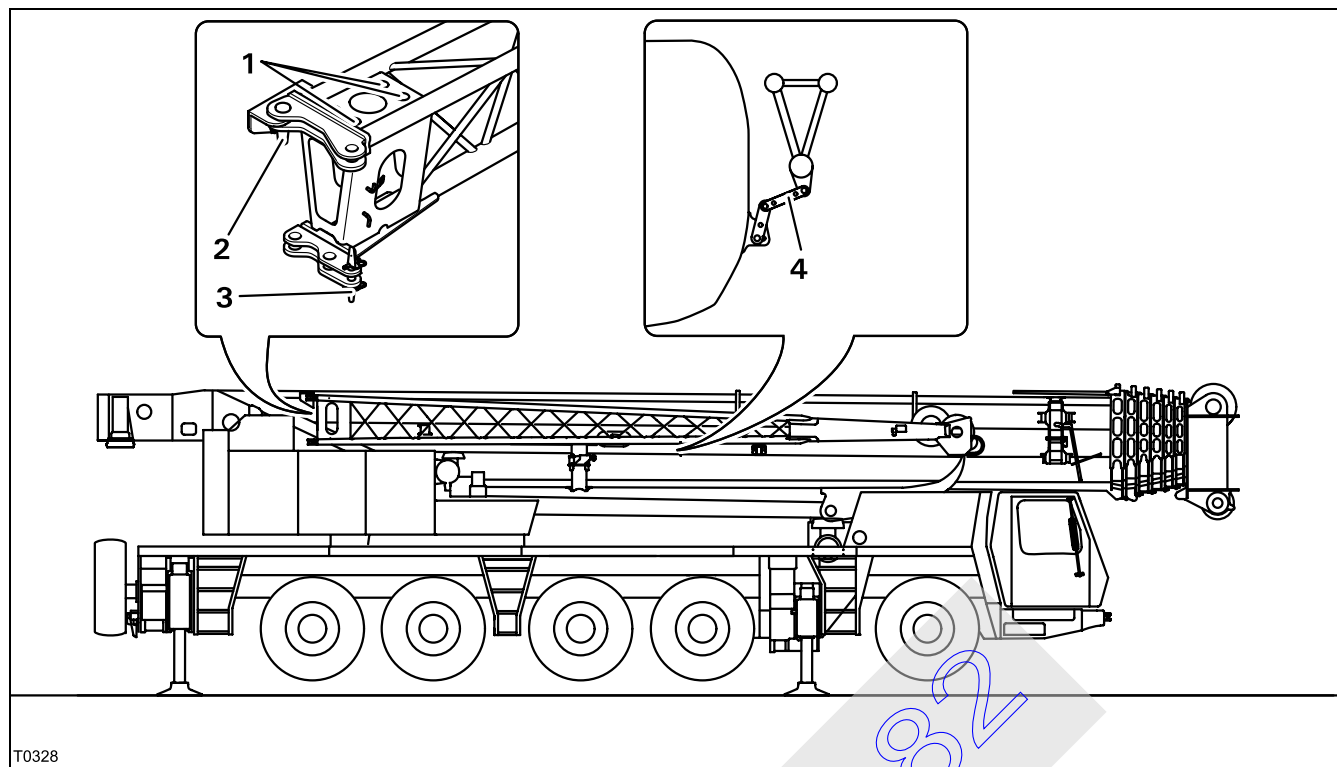

T0328

Only when section 2 is folded to the side:

- Check the following connections and establish them if necessary:
 - In the *middle* area, the connection (4) is in the position *section 2/main boom*; ■■■► p. 3 - 52.
 - In the *rear* area, the connection (2) between section 2 and the main boom is established; ■■■► p. 3 - 53.
- The unrequired pins (1) are secured in the retaining sheet. The unrequired pin (3) is secured in the hole for the pin.

Transport condition with removed lattice extension

The transport condition for the removed lattice extension is established when all of the following connections have been made.

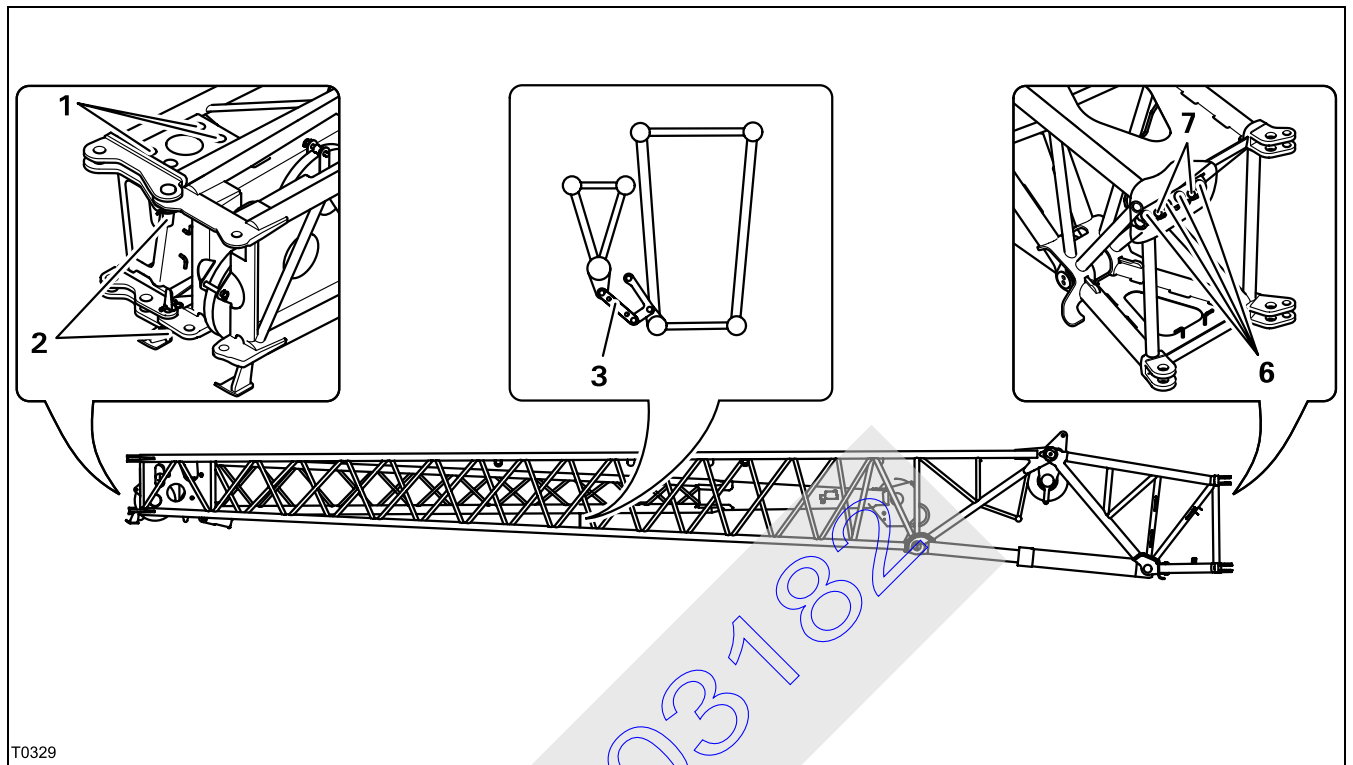

- Check the following connections and establish them if necessary.
 - In the *Rear* area, the connection (2) between section 1 and section 2 is established; ■■■► p. 3 - 57.
The unrequired pins (1) are secured in the retaining sheet.
 - In the *Middle* area, the connection (3) is in the position *Section 1/ Section 2*; ■■■► p. 3 - 51.
 - The pins (6) and (7) on section 1 are secured with retaining pins.

3.6.3

Checking the locking device on the hose drum

A hose drum on the left hand side of the main boom provides the hydraulic supply. The hosedrum is equipped with a locking device. The locking device is only needed for installing and removing the hose drum.

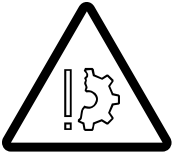

Risk of damage to hydraulic hoses

Always check that the locking device is undone before beginning operation with the lattice extension.

By doing this you prevent the hydraulic hoses tearing when the main boom is telescoped.

Undoing the locking device

The locking device must be undone before you operate with the lattice extension.

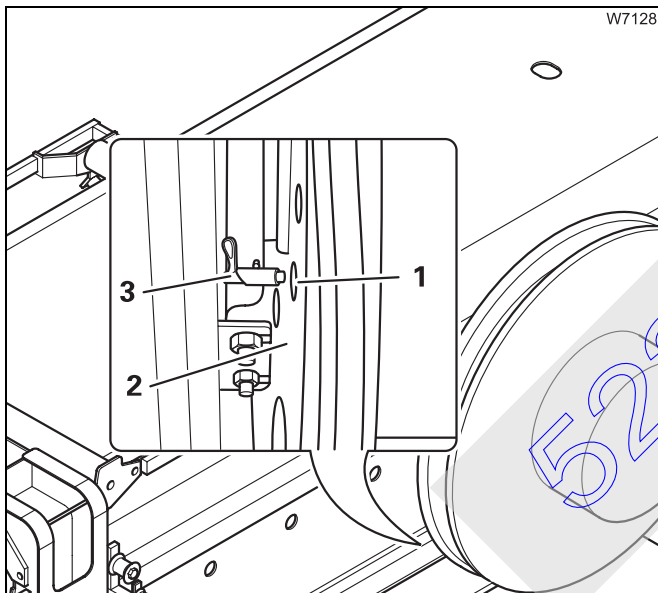

- Check if the spring latch (3) is inserted in one of the bores (1). In this case, you must undo the locking device.
- Withdraw the spring latch (3) from the bore in the flanged wheel (2).

Inserting the locking device

If the hose drum has to be removed, you have to insert the locking device beforehand.



Risk of accidents from uncontrolled turning of hose drum

The locking device always has to be inserted before the hose drum is removed. Otherwise, the hose drum will twist uncontrollably against the holder and could injure you.

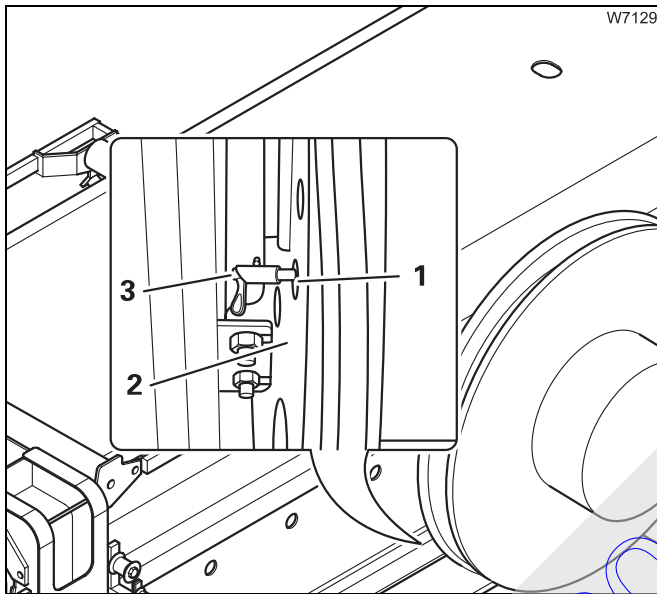

- There are eight bores (1) spread around the inner flanged wheel (2) of the hosedrum.
- Turn the hose drum until a bore is in front of the spring latch (3).
- Move the spring latch into the bore, the hose drum is secured against twisting.

Position of the hydraulic connections

Before operating the lattice extension, you must ensure the hydraulic connections are in the *Lattice extension operation* position.

Before working with the main boom for longer periods, you must place the hydraulic connections in the *main boom operation* position, so that the hose drum is not put under unnecessary strain.





Risk of accidents from hydraulic hoses springing back

If you detach the strain relief after the locking device has been released, do not under any circumstances let go of the strain relief before it has been re-attached. If you let go of the strain relief, the hydraulic hoses will spring back uncontrollably due to the spring force in the hose drum and may injure persons or damage parts of the truck crane.

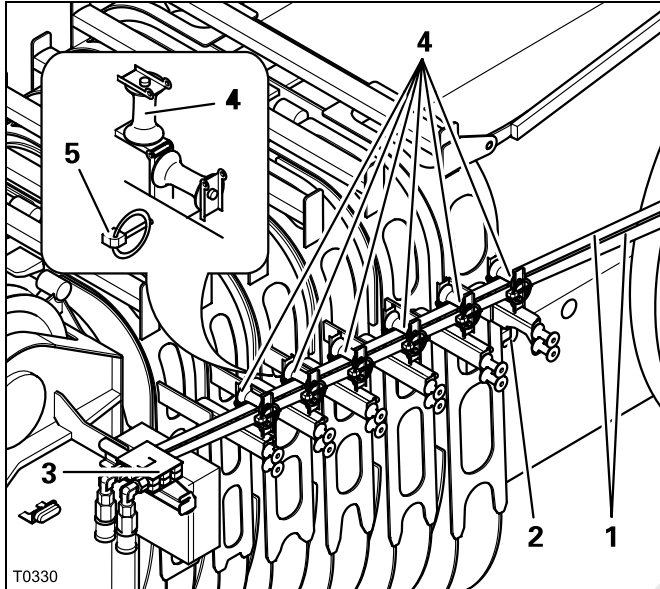

Position for working with the lattice extension

The locking device on the hose drum must be undone; ▣▣▣ p. 3 - 38.

- Loosen the hinged pins (5) and fold up the guide sheaves (4).
- Take the strain relief out of the holder (2) and pull the hydraulic hoses (1) towards the main boom head.
- Hook the strain relief onto the holder (3).
- Fold down the guide sheaves (4) and secure them with the hinged pins (5).

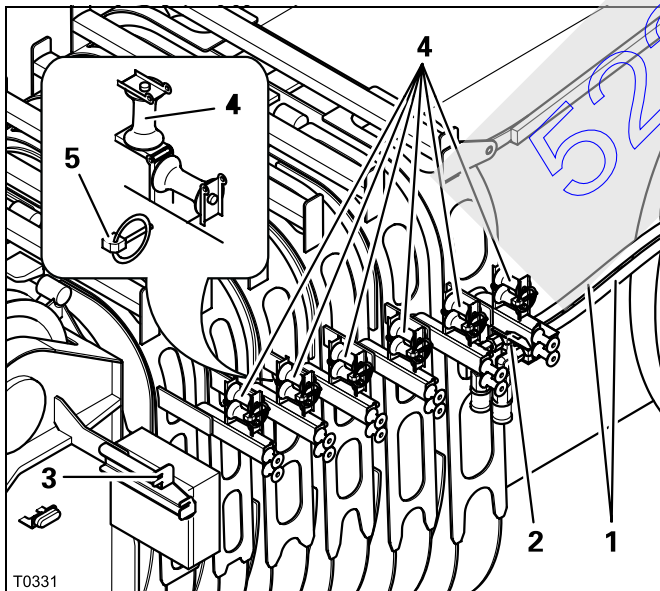

Position for working with the main boom

The locking device on the hose drum must be undone; ▣▣▣ p. 3 - 38.

- Loosen the hinged pins (5) and fold up the guide sheaves (4).
- Release the strain relief on the holder (3) and attach it to the holder (2).
- Fold down the guide sheaves (4) and secure them with the hinged pins (5).

3.6.4

Installing/removing the hose drum

Installing the hose drum

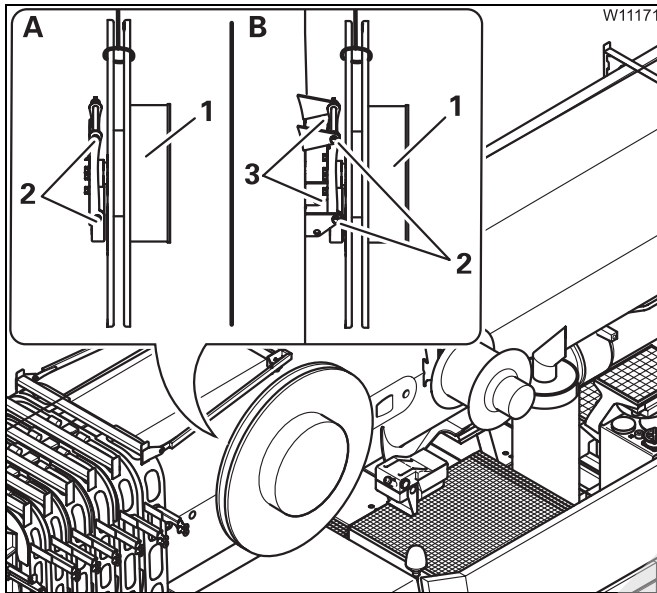

- (A) – Attach the hose drum (1) to a reservoir.
- Pull the pins (2) out of the holder.
- (B) – Hoist the hose drum (1) between the holders (3).
- Fasten the hose drum (1) with the pins (2).
- Secure the pins using spring cotters.

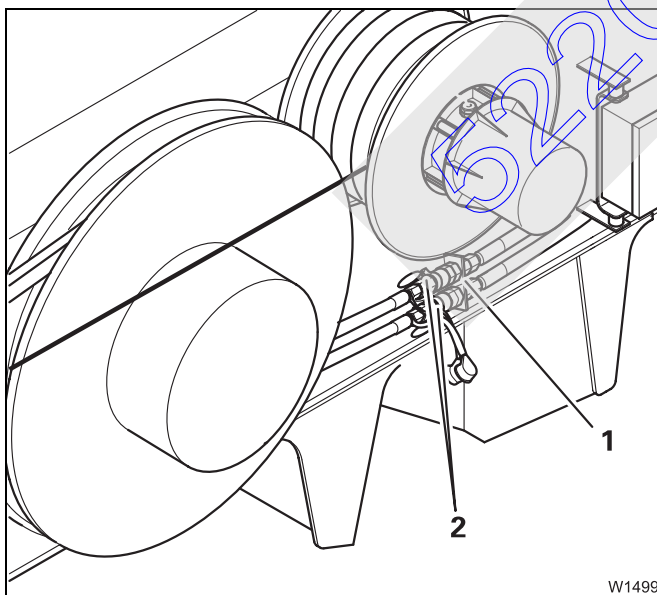

- Connect the quick release couplings (2) to the half couplings (1).
Matching half couplings are colour-coded.

If no quick release couplings have been attached:

- Connect the cables to the rear of the hose drum.



Removing the hose drum

Depending on the driving mode of the truck crane the hose drum must be removed for on-road driving with a maximum axle load of 12 t (26 500 lbs);
 ■■■▶ *Operating instructions GMK 5220.*

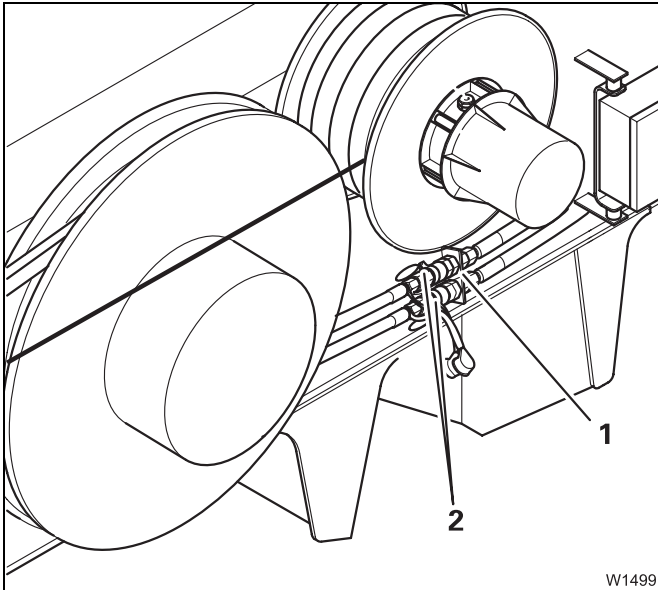

- Pull off the quick release couplings (2) on the half couplings (1).

- Place the protective caps on the couplings.

If no quick release couplings have been attached:

- Separate the cables on the rear of the hose drum.

- Close the connections.

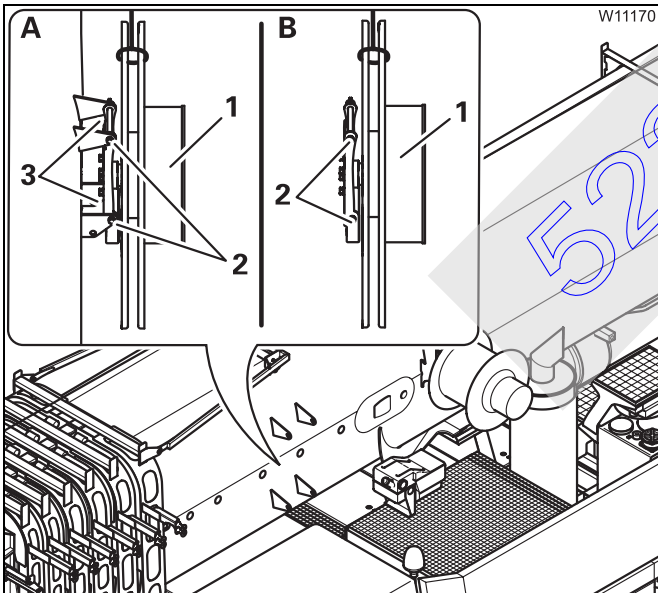

- (A) - Attach the hose drum (1) to a reservoir.

- Pull the pins (2) out of the holder.

- Hoist the hose drum (1) out of the holder (3).

- (B) - Insert the pins (2) into the bores.

- Secure the pins (2) with spring cotters.

- Stow away the hose drum (1) safely for transportation.

3.6.5

Establishing/disconnecting the hydraulic connection

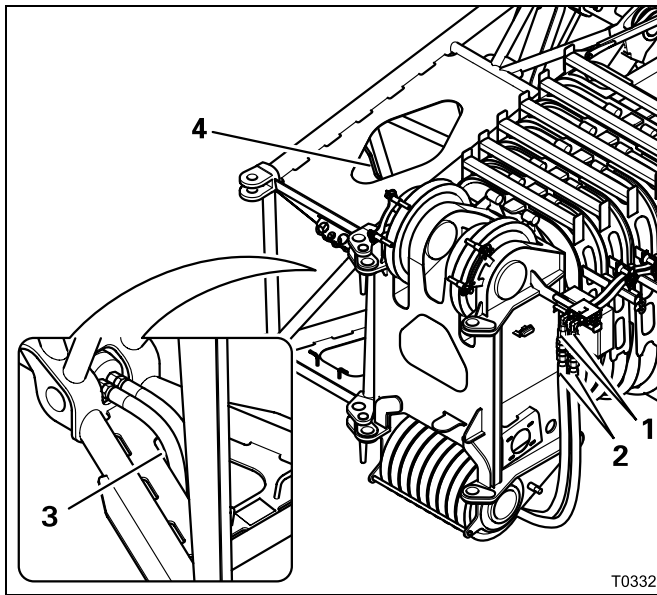

Establishing the hydraulic connection

- If necessary, bring the connections (1) into the position for working with the lattice extension; see p. 3 - 40.
- Remove the hose line (2) from the clamp (4).
- Feed the hose lines towards the left hand side through the lower opening (3) in Part 1 under the boom head.
- Remove the protective caps to the connections (1) and attach the hose lines (observe the colour code).



Risk of damage to hydraulic hoses

Feed the hydraulic hoses under the main boom head in such a way that they hang freely. Take care that the hoses are not torn off when folding the lattice extension. This prevents damage to the hydraulic hoses.

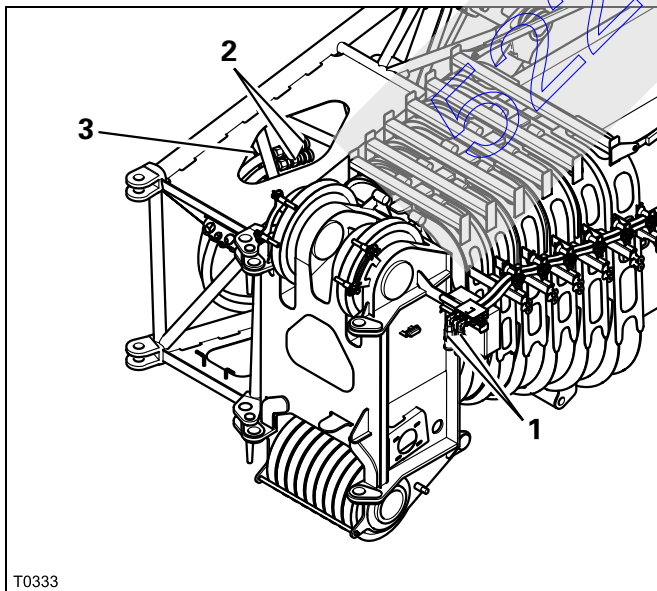

Breaking the hydraulic connection

- Remove the hose lines (2) from the connections (1).
- Close off the hose lines and the connections (1) with the protective caps.
- Secure the hoses on the holder (3) on Part 1.

Blank page

52203182

3.6.6

Folding the run-up rail out/in

The run-up rail is folded out for rigging and folded back in for on-road driving after unrigging.

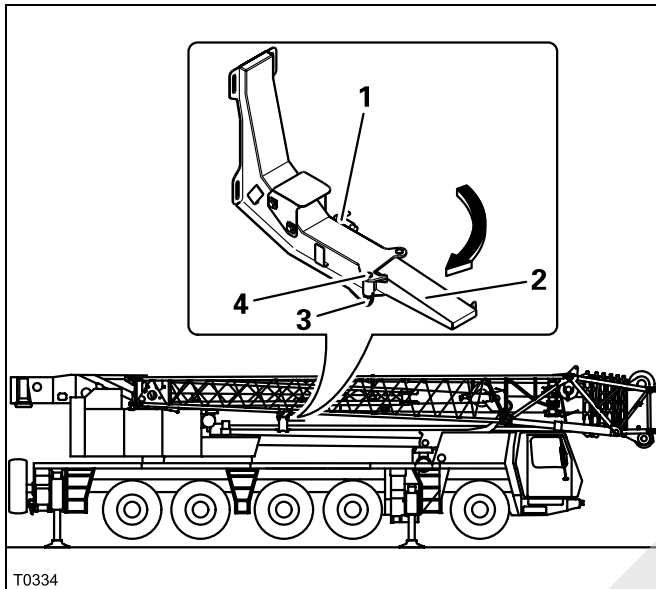

Folding out the run-up rail

- Release the spring latch (1).
- Fold out the run-up rail (2) until the locking bar (3) engages in the bore hole (4).



Risk of accidents when permitted overall width is exceeded

Always fold in the run-up rail before driving. When the run-up rail is folded out, the overall width specified for on-road driving is exceeded.

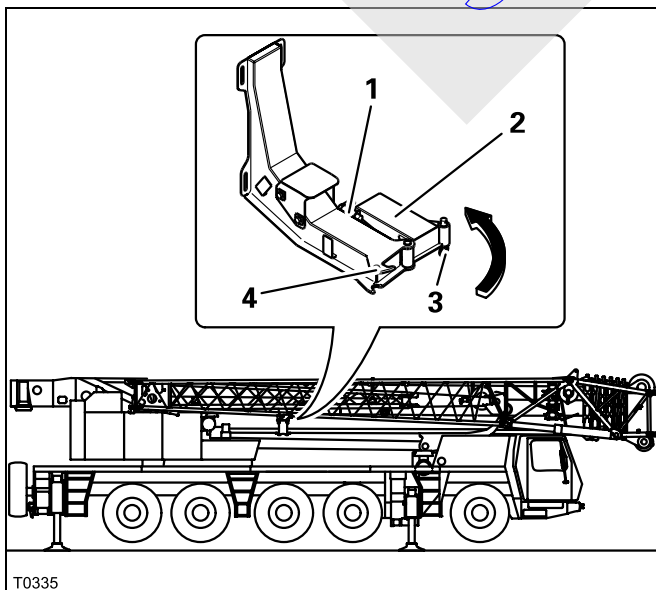

Folding in the run-up rail

- Pull the locking bar (3) downwards against the spring force, and out of the bore hole (4).
- Fold out the run-up rail (2) slightly and let go of the locking bar (3).
- Fold in the run-up rail completely.
- Secure the run-up rail with the spring latch (1).

3.6.7

Connections with folded lattice extension

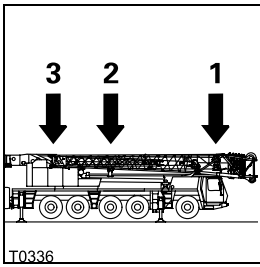

The lattice extension is swung to the side of the main boom in the folded up position.

In this position there are four areas on the main boom basic section, where various connections have to be disconnected and reconnected again during rigging and unrigging:

- 1 *Front* area, in front of the locking point at 100%
- 2 *Middle* area, in front of the locking point at 50%
- 3 *Rear* area, under the side panelling

There are connecting points in each area. Depending on the rigging mode and job, different sections of the lattice extension have to be connected one below the other or with the main boom basic section.



Risk of accidents due to falling parts

Always secure the pins both in the connecting points and in the holders, using retaining pins.

This prevents unsecured pins from becoming loose, falling out and causing injuries.

Connections in the front area

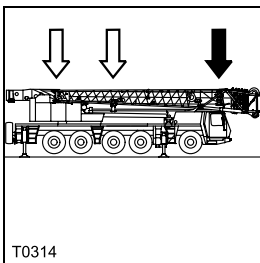

In the *Front* area, there is a connection between section 1 and the main boom.

This connection must be established if the lattice extension is folded at the side of the main boom during unrigging or installation.

The connection must be removed when the lattice extension is being rigged or removed.

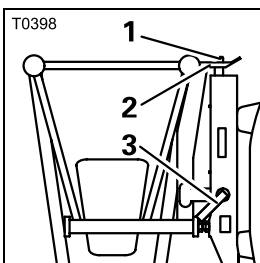

The connection consists of the pin (3), the slewing axis (1) on the basic section and the holder (2) on section 1.

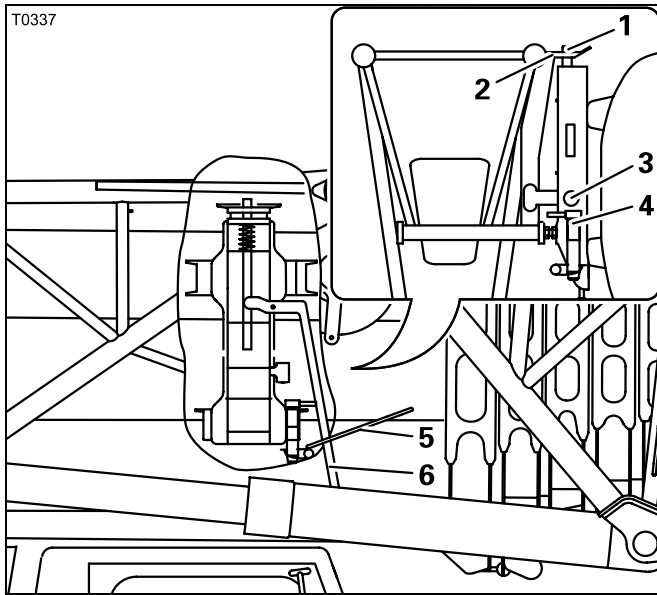

Establishing a connection

To establish a connection, the lattice extension must be on the run-up rail.

- Check if the pin (4) is pulled out of the bore hole (3).
- Check if the lever (6) is under the lever (5).
- Swing the lattice extension sideways onto the main boom on the run-up rail. First the slewing axle (1) is pressed down by the holder (2) and then it is locked in the holder.



Risk of accidents from a falling lattice extension

Always fasten section 1 to the main boom with the pin. When section 1 is only attached at the slewing axis, the lattice extension could slip from the slewing axle (e.g. when working with the main boom) and fall down.

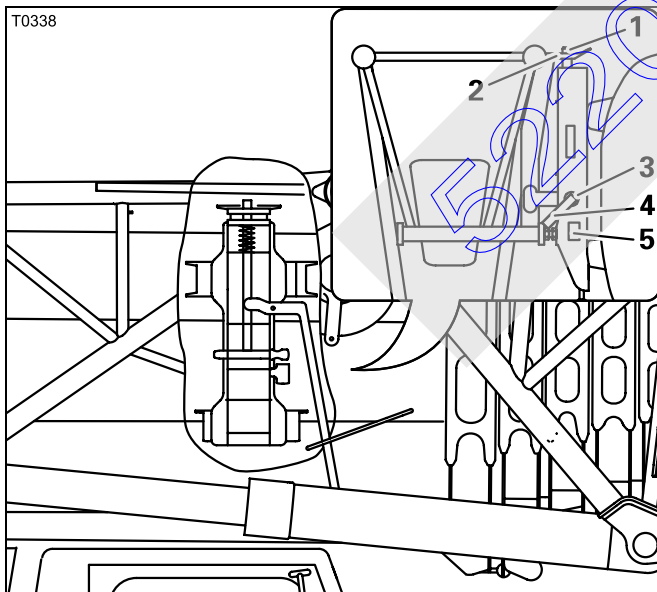

- Check if the slewing axle (1) projects upwards from the bracket (2).
- Remove the retaining pin and pull the pin (4) out of the holder (5).
- Insert the pin (4) through the bore hole (3).
- Secure the pin (4) using the retaining pin.

The connection is now established. The pin (4) prevents the retraction of the slewing axis and fastens section 1 to the main boom.



Releasing the connection

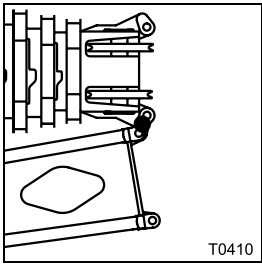

- Check that the connection has been made; p. 3 - 58.
- Secure the lattice extension with a guide rope; p. 3 - 32.

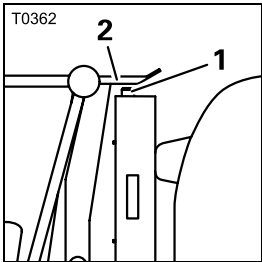

– With hydraulically derricking lattice extension

- Fully raise the lattice extension; p. 3 - 91.
- Check if the holder (2) has moved completely out of the slewing axis (1).
If this is the case, the connection has been broken.

If the slewing axis is still partly in the holder, then you must pull it in manually:

– Manually pulling in the slewing axis

If the lattice extension cannot be fully raised out of the slewing axis, you must pull in the slewing axis as follows:



Risk of accidents from a falling lattice extension

Before removing the connection, ensure that section 1 is pinned at the right of the main boom head.

This will prevent the lattice extension from falling and causing injury to you or other persons.



Risk of accidents from lattice extension swinging of its own accord

Always secure the lattice extension with a guide rope on the main boom before retracting the slewing axis.

This will prevent the lattice extension from slipping off the run-up rail, swinging around and knocking you off the carrier or injuring other persons in the slewing range.

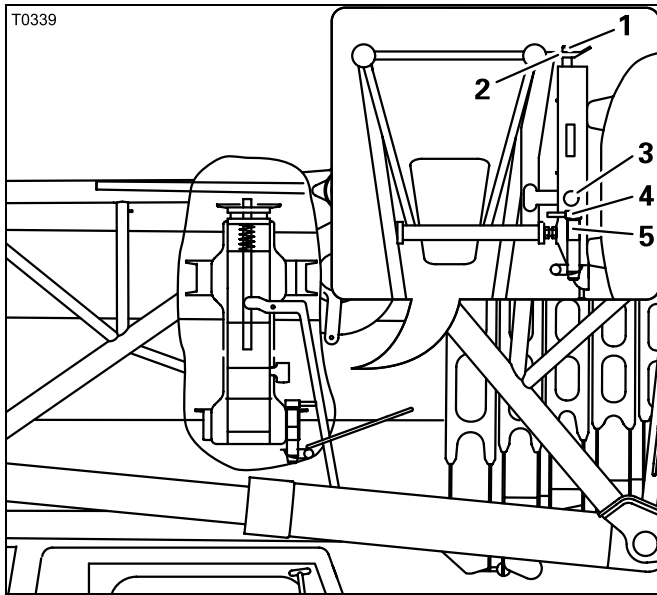

- Withdraw the pin (4) from the bore (3) and insert it into the holder (5).
 - Secure the pin (4) using the retaining pin.
- You can now retract the slewing axis (1) so that it no longer protrudes from the holder (2).

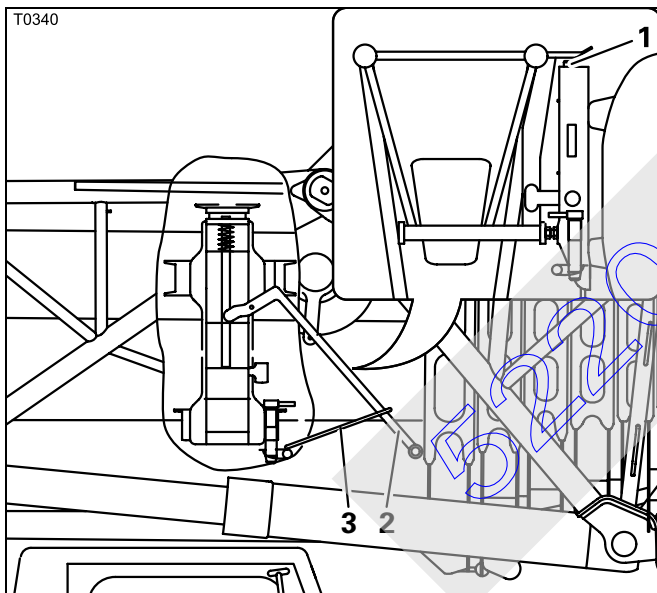

- Push the lever (2) upwards against spring force.
 - Set down the lever (2) on the rest (3).
- The slewing axis (1) is now retracted and you can swing the lattice extension from the main boom head.



Moving the *Front* connection into the *Unrigging* position

Before you fold the lattice extension onto the side during unrigging, the *Front* connection must be moved into the *Unrigging* position.



Danger of becoming trapped due to swinging lattice extension

Start the subsequent work only if the lattice extension is locked in front of the main boom head or it is secured against swinging around.

This will prevent the lattice extension from swinging inadvertently to the side of the main boom and possibly crushing you.

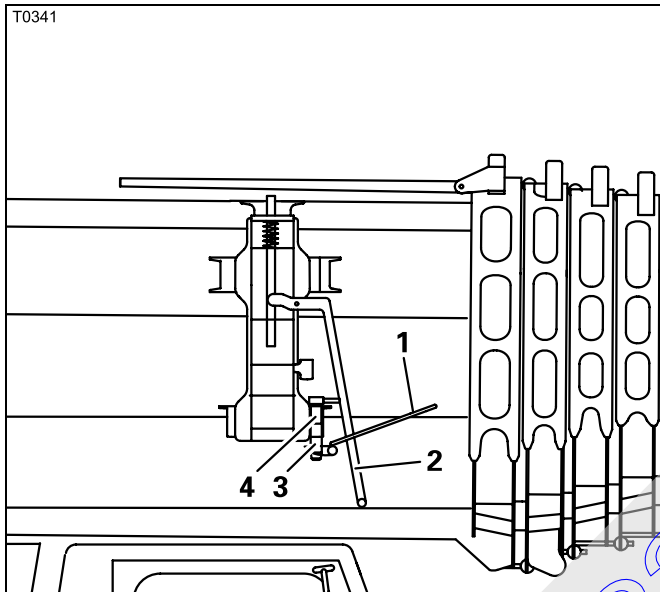

The following prerequisites must be fulfilled before unrigging:

- The pin (3) must be secured in the holder (4).
- The lever (2) must be underneath the rest (1).
- Insert the pin (3) into the bracket (4) if necessary, and secure it with the retaining pin.
- If necessary, raise the lever (2) to the side from the rest (1) and yield slightly to the spring force.

The *Front* connection is then in the *Unrigging* position.

Connections in the middle area

The connection in the *Middle* area consists of a locking bar with two pins. Depending on the position of the locking bar, different sections are connected with one another. There are three positions:

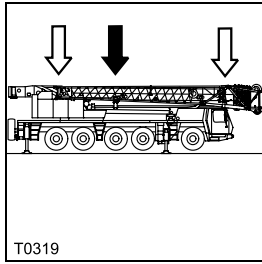

- Position Section 1/section 2
- Position Section 2/main boom
- Position At section 1

Position Section 1/section 2

This position must be established in the following circumstances:

- when rigging the **21 m (69 ft)** swing-away lattice extension – before the lattice extension is swung in front of the main boom head.
- when unrigging the **21 m (69 ft)** swing-away lattice extension – after section 2 was swung towards section 1.
- when unrigging the **12 m (39 ft)** swing-away lattice extension – when section 2 is installed on the main boom.
- before removing the **21 m (69 ft)** swing-away lattice extension.

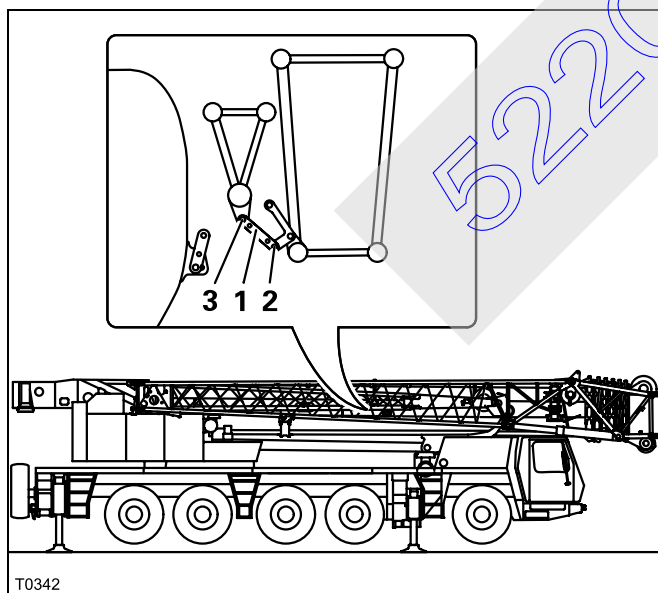

- Fasten the locking bar (1) to section 1 with the pin (2).
- Fasten the locking bar (1) to section 2 with the pin (3).
- Secure the pins using the retaining pins.



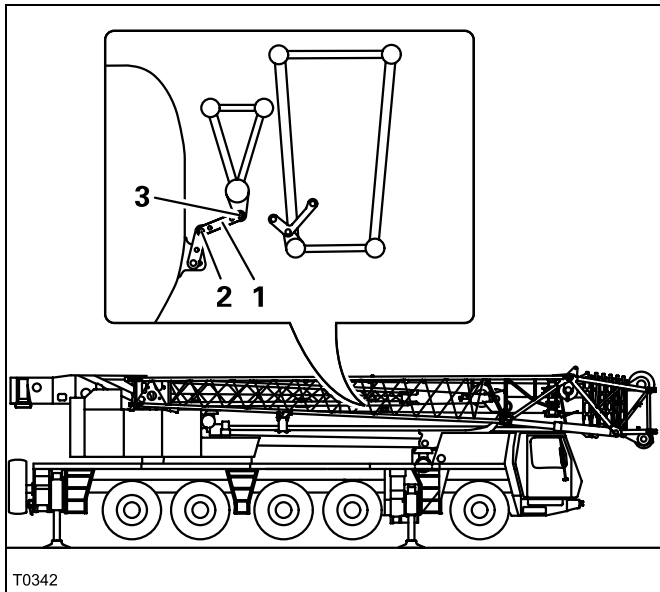

Establishing the position Section 2/ main boom

This position must be established in the following circumstances:

- when unrigging the 12 m (39 ft) swing-away lattice extension – when section 2 is installed.
- before removing – when only section 1 is to be removed.
- Fasten the locking bar (1) to the main boom with the pin (2).
- Fasten the locking bar (1) to section 2 with the pin (3).
- Secure the pins using the retaining pins.

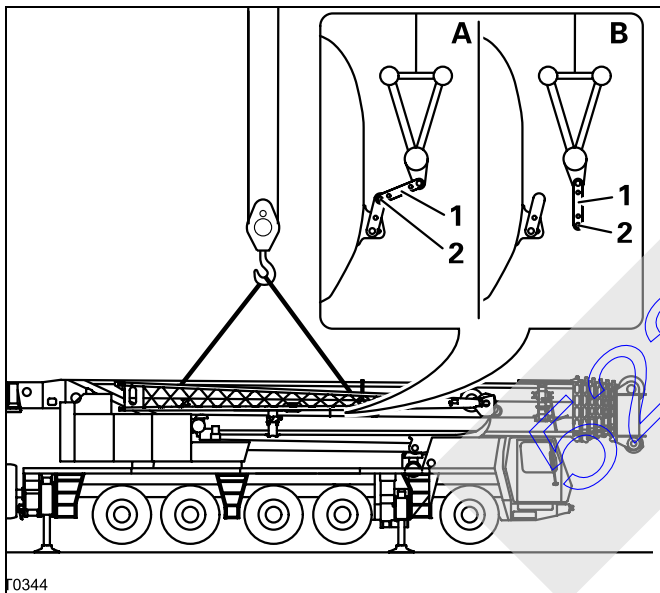

Releasing the position Section 2/main boom

This position must be released if only section 2 is to be installed and removed.

- Sling section 2; see p. 3 - 10.
- (A) – Loosen the retaining pin and pull out the pin (2).
- (B) – Fold down the locking bar (1).
- Insert the pin (2) into the locking bar (1).
- Secure the pin with the retaining pin.

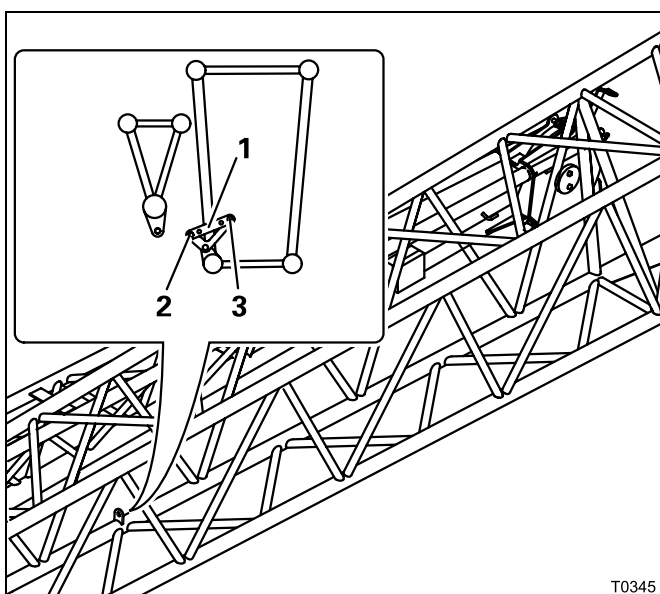

Position at section 1.

This position must be established in the following circumstances:

- when rigging the 21 m (69 ft) swing-away lattice extension – before section 2 is swung in front of section 1.
- Fasten the locking bar (1) to section 1 with the pins (2) and (3).
- Secure the pins using the retaining pins.

Connections in the rear area

In the *Rear* area there are three different connections:

- the connection between section 2 and the main boom
- the connection between section 1 and the main boom
- the connection between section 1 and section 2

Connection between section 2 and the main boom

The connection must be disconnected:

- when rigging the 21 m (69 ft) swing-away lattice extension
- when removing the 21 m (69 ft) swing-away lattice extension
- when removing section 2

The connection must be made:

- when unrigging the 21 m (69 ft) swing-away lattice extension
- for operation with the 12 m (39 ft) swing-away lattice extension when section 2 is installed
- when removing section 2

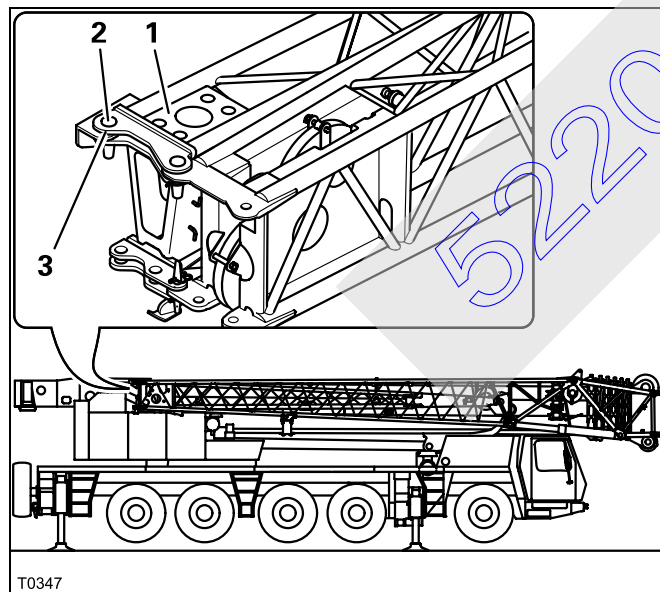
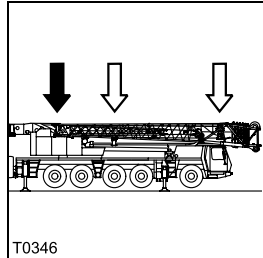

Establishing a connection

- Align the connection point (3).
- Loosen the retaining pin and remove the pin (2) from the retaining sheet (1).
- Insert the pin (2) into the connection point (3) and secure it with the retaining pin.



Releasing the connection – with a 21 m (69 ft) lattice extension

- Before releasing the connection, check that
 - the connection is established in the *Front* area; ■■■► p. 3 - 47,
 - Now the connection between section 2 and section 1 is established; ■■■► p. 3 - 57.



Risk of accidents due to falling parts

Before releasing the connection, make sure that all the connections listed above are established.

In this way you will prevent either section 2 or section 1 or both falling down when the connection is released.

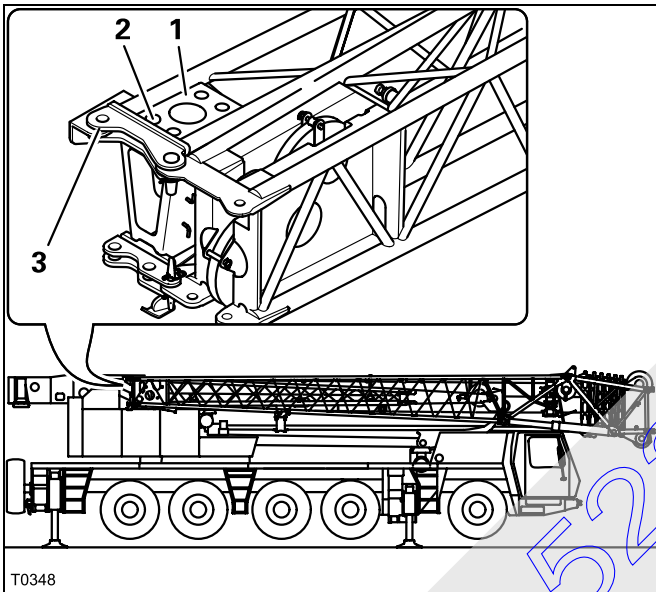

- Loosen the retaining pin and remove the bolt (2) from the connecting point (3).
- Insert the pin into the retaining sheet (1).
- Secure the pin with the retaining pin.

Releasing the connection – when removing section 2

- Check if section 2 is slung in the centre of distribution; ■■■► p. 3 - 10.



Risk of accidents through section 2 falling down

Make sure that section 2 is slung in the centre of distribution before you release the connection between section 2 and the main boom.

This will prevent section 2 from falling down when this connection is released.

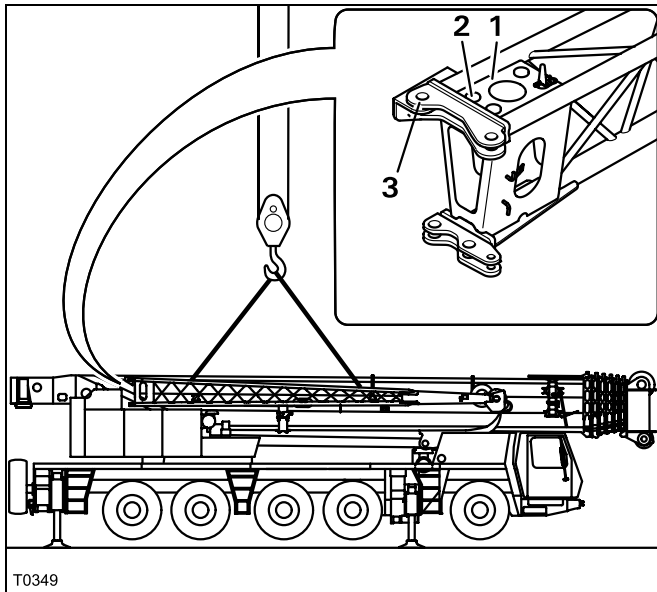

- Loosen the retaining pin and remove the bolt (2) from the connecting point (3).
- Insert the pin into the retaining sheet (1).
- Secure the pin with the retaining pin.

Connection between section 1 and the main boom



This connection does not apply to truck cranes that are supplied with a 21 m (69 ft).

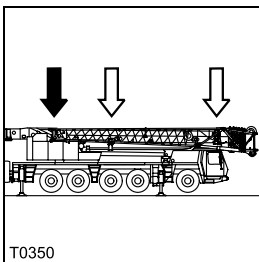

This connection must be established if the 12 m (39 ft) swing-away lattice extension is folded in to the side during unrigging.

The connection must be released before the 12 m (39 ft) swing-away lattice extension is swung towards the main boom head, when section 2 has been removed.

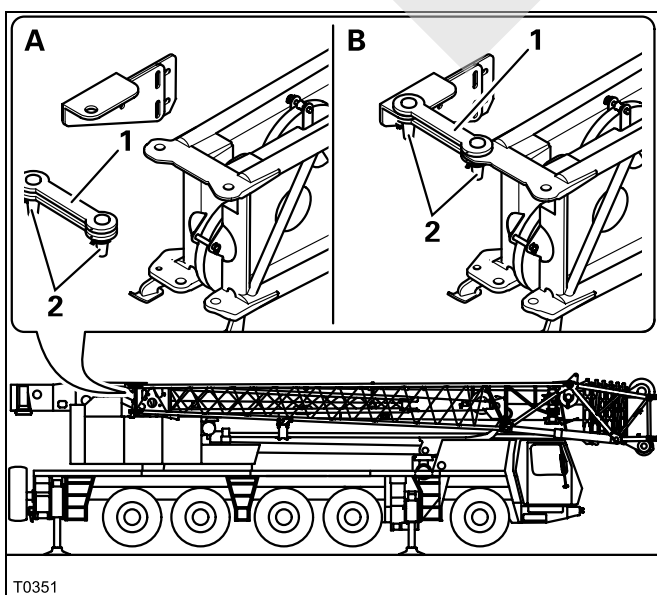

Establishing a connection

The correct original position is reached when the connection in the *Front* area is established; p. 3 - 47.

- (A) – Release the retaining pin and remove the pin (2) from the retaining strut (1).
- (B) – Fasten the retaining strut (1) to the main boom with a pin (2).
- Fasten the retaining strut (1) to section 2 with the other pin (2).
- Secure the pins using the retaining pins.



Releasing the connection

- Check if the connection is made in the *Front* area;  p. 3 - 47.



Risk of accidents through section 1 falling down

Check that the connection is made in the *Front* area.

This will prevent section 1 from falling down when this connection is released.

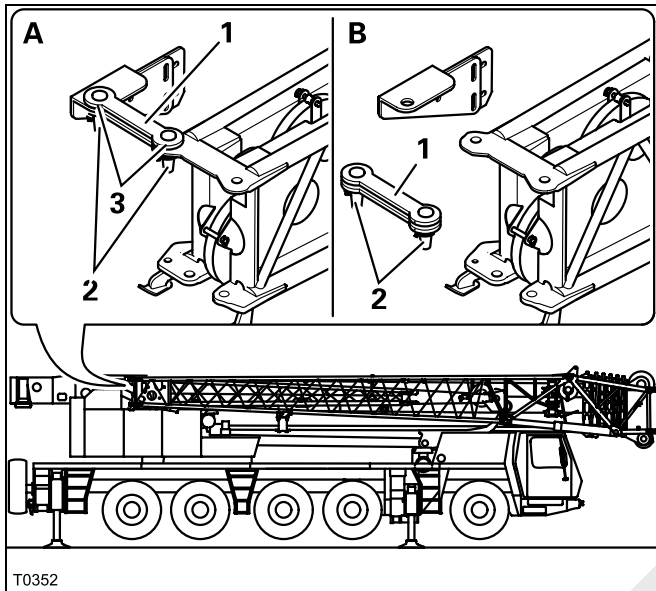

- **(A)** – Release the retaining pins and remove the pins **(2)** from the stay rods **(3)**.
- Remove the retaining strut **(1)**.
- **(B)** – Fasten the retaining strut **(1)** to the main boom with a pin **(2)**.
- Secure the pins using the retaining pins.
- Stow the retaining strut with the pins for crane operation (e.g. in the storage box).

Connection between section 1 and section 2

All information in this section only applies to the operation of the 12 m (39 ft) swing-away lattice extension, when section 2 is installed.

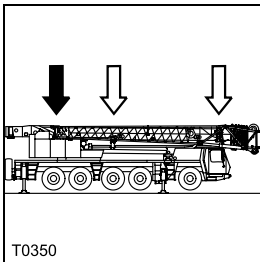

This connection is made after the 12 m (39 ft) swing-away lattice extension has been swung to the side of the main boom during unrigging.

This connection is released before the 12 m (39 ft) swing-away lattice extension is swung towards the main boom during rigging.

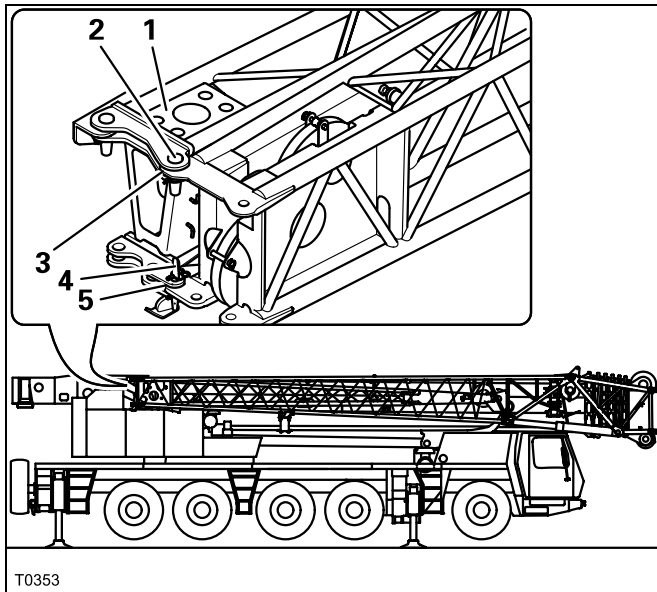

Establishing a connection

- Remove the retaining pins and pull the conical pin (4) and another pin (2) out of the retaining sheet (1).
- Insert the pin (2) into the upper connecting point (3).
- Insert the conical pin (4) into the lower connecting point (5).
- Secure the pins (2) and (4) using the retaining pins.

Releasing the connection

- Before releasing the connection, check that
 - the connection is established in the *Front* area; ■■■► p. 3 - 47,
 - the connection in the *Middle* is in the position *Section 2/main boom*; ■■■► p. 3 - 52,
 - Release the connection between section 2 and the main boom in the *Rear* area; ■■■► p. 3 - 53.



Risk of accidents due to falling parts

Before releasing the connection, make sure that all the connections listed above are established.

In this way you will prevent either section 2 or section 1 or both falling down when the connection is released.

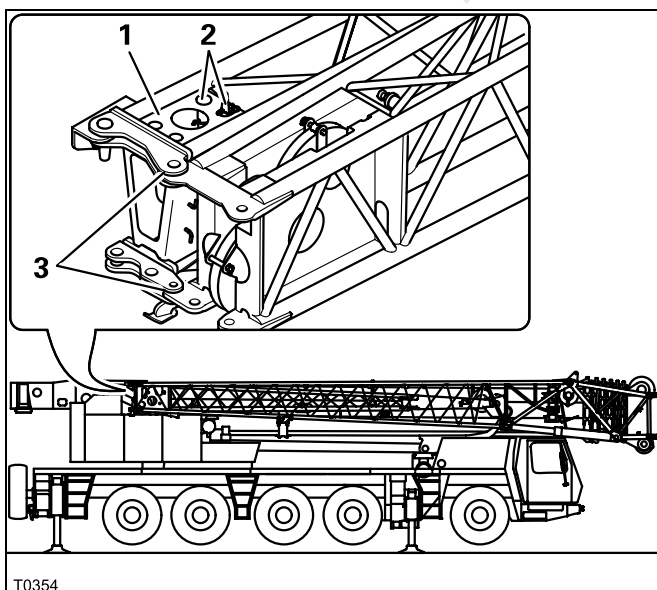

- Remove the retaining pins and pull the pins (2) out of the connecting points (3).
- Insert the pins into the retaining sheet (1).
- Secure the pins using the retaining pins.

3.6.8

Connecting/disconnecting the slewing connection

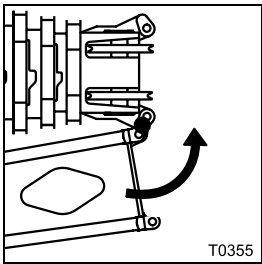

The slewing connection is created on the right of the main boom head using two pins. The pins required can be found in the holders at the rear of section 1.



Risk of accidents due to falling parts

Always secure the pins both in the connecting points and in the holders using retaining pins. This prevents unsecured pins from becoming loose, falling out and causing injuries.

Creating a slewing connection

The slewing connection must be established before the lattice extension has been swivelled in front of the main boom head during rigging.

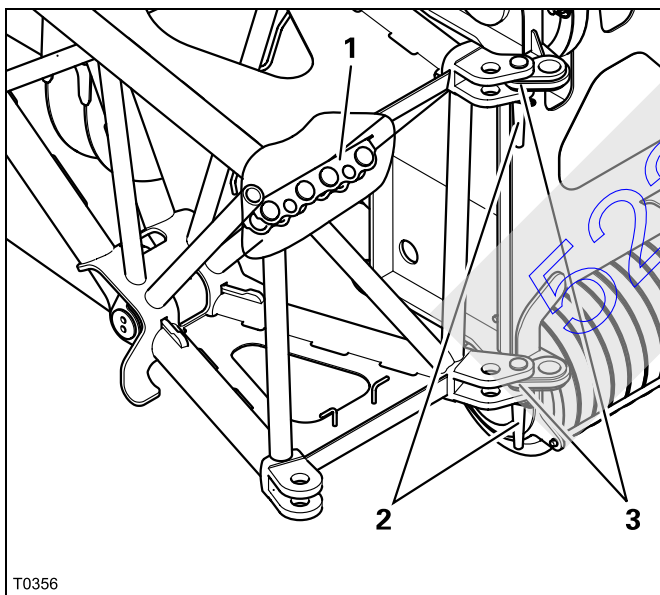

The connecting points for the slewing connection will only align when the main boom is completely retracted.

- Remove the retaining pins and pull the pins (2) out of the holder (1).
- Insert the pins into the connecting points (3).
- Secure the pins using the retaining pins.

Releasing a slewing connection

The connection must be released after the lattice extension is swivelled onto the main boom side and pinned there during unrigging.



Risk of accidents from a falling lattice extension

When the lattice extension is folded to the side, make sure that all the connections are created as stipulated according to *CHECKLIST: Unrigging the 12/21 m (39/69 ft) swing-away lattice extension* for the lattice extension currently installed;  p. 3 - 25, point 21. and point 24. to point 26.

In this way you prevent the lattice extension from slipping or falling from the boom when it is operated again after the connection is released and causing injury to you or other persons.



Danger of crushing by swinging lattice extension

When removing, always secure the lattice extension with a guide rope before releasing the slewing connection, and only insert the pins in the holders when the lattice extension has been set down.

In this way you prevent the swinging lattice extension from knocking you off the ladder, or crushing you against the main boom.

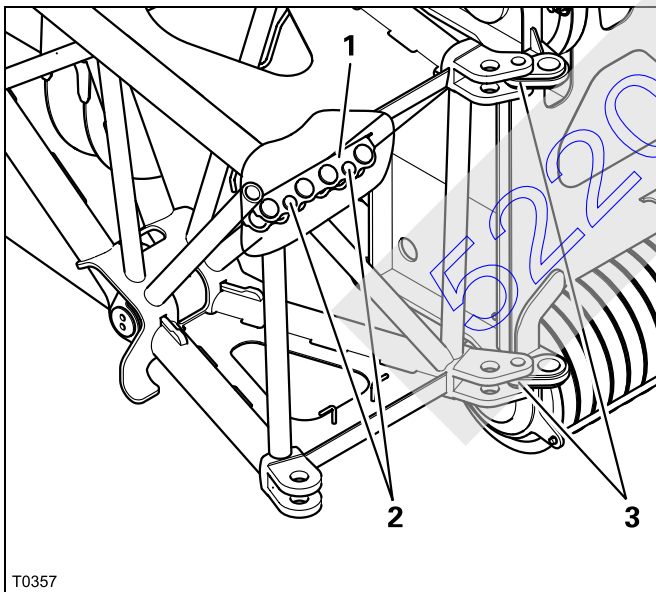

- Remove the retaining pins and pull the pins (2) out of the connecting points (3).
- Insert the pins into the holder (1).
- Secure the pins using the retaining pins.

T0357

3.6.9

Connections on the left and right of the main boom head

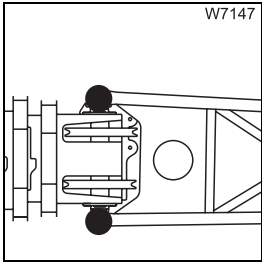

The connections on the right and left on the main boom head are made using pins. The pins required can be found in the holders at the rear of section 1.



Risk of accidents due to falling parts

Always secure the pins both in the connecting points and in the holders using retaining pins. This prevents unsecured pins from becoming loose, falling out and causing injuries.

Establishing connections

The connections must be established after the lattice extension has been swivelled in front of the main boom head during rigging.



If the pins cannot be inserted, you can take the strain off the connecting points;  *Relieving the connecting points*, p. 3 - 63.

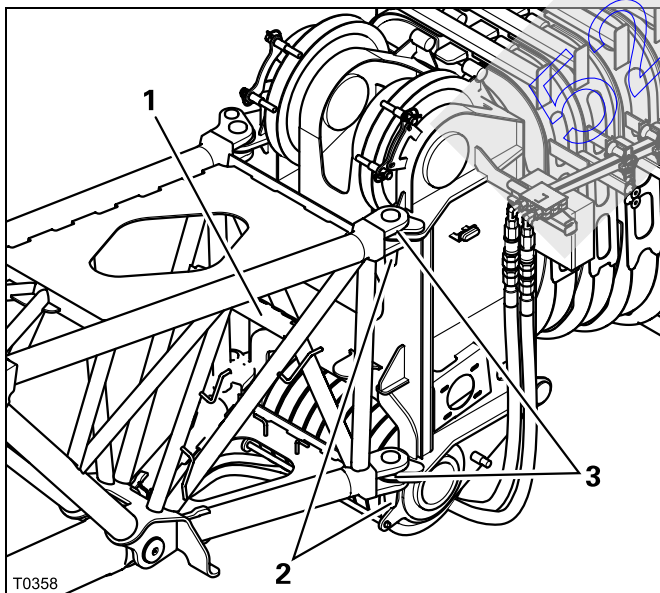

Left-hand connection

- Swing the lattice extension in front of the main boom until the connecting points (3) align.
- Remove the retaining pins and pull the pins (2) out of the holder (1).
- Insert the pins into the connecting points (3).
- Secure the pins using the retaining pins.

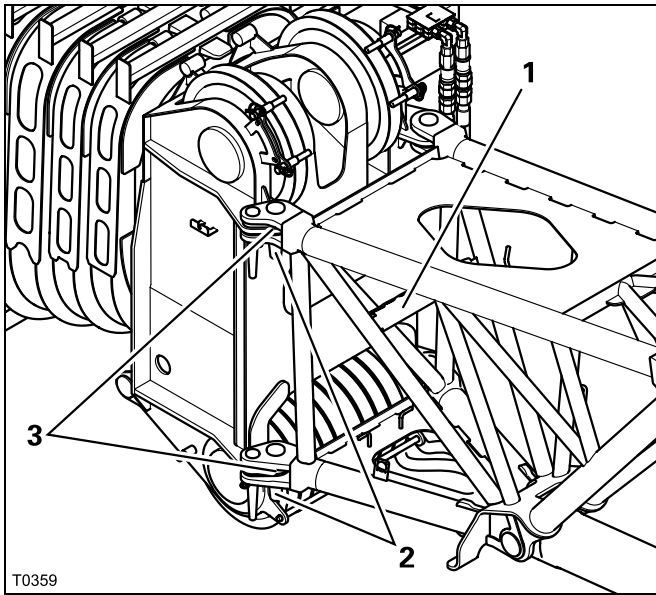

Right-hand connections

- Remove the retaining pins and pull the pins (2) out of the holder (1).
- Insert the pins into the connecting points (3).
- Secure the pins using the retaining pins.

Releasing connections

The connections must be released so that the lattice extension can be swung to the side of the main boom during unrigging.

Right-hand connection

Only release this connection when the connection on the left-hand side is still intact.



Danger of crushing if procedure is not followed

Release the right-hand connection first, and then the left-hand connection. In this way you prevent the lattice extension from swinging round when you release the right-hand connection, which could knock you from the ladder or lead to you becoming crushed between the lattice extension and the main boom.



Risk of accidents from a falling lattice extension

On this side, **only** release the two inner pins. The outer pins for the slewing connection must remain inserted. If you release the slewing connection, the lattice extension will fall down when the pins on the left-hand side are released and could injure yourself or other people.



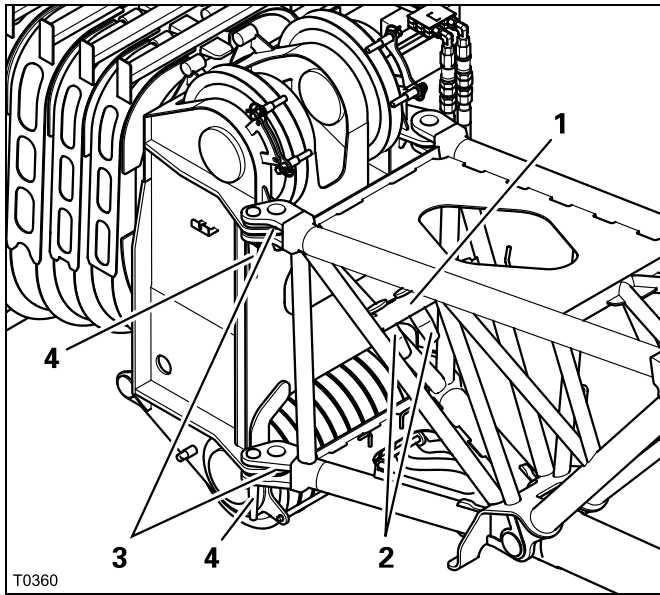

Right-hand connection

The pins (4) for the slewing connection must remain inserted!

- Remove the retaining pins and pull the pins (2) out of the connecting points (3).
- Insert the pins into the holder (1).
- Secure the pins using the retaining pins.

Left-hand connection



Only release the left-hand connection after the right-hand connection has been released. The left-hand connection stops the lattice extension from swinging round when the right-hand connection is released.

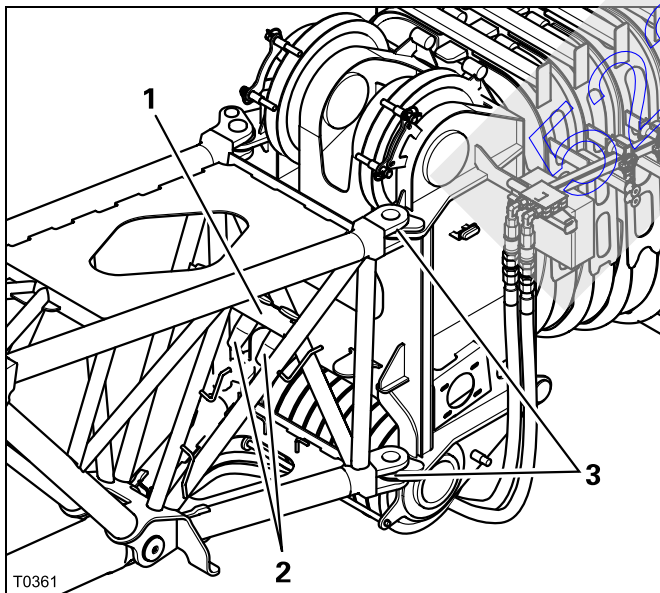

- Remove the retaining pins and pull the pins (2) out of the connecting points (3).
- Insert the pins into the holder (1).
- Secure the pins using the retaining pins.

Relieving the connecting points

The dead weight of the lattice extension can cause misalignment of the bearing points, and can also weight down the pins and make it impossible to knock them out.

Proceed in the following manner to relieve the strain on the connecting points:

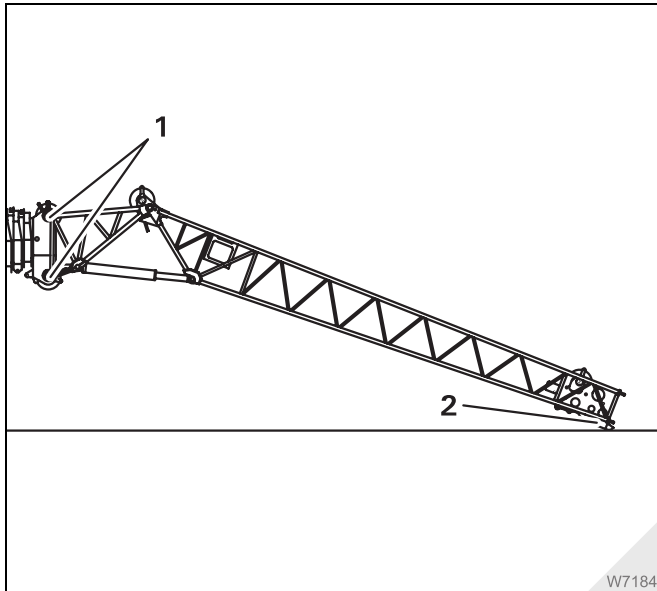

For hydraulically derricked lattice extensions

- Lower the lattice extension until it is on the ground with the supports (2) (if necessary, override the lifting limit switch).
- Continue to lower carefully until the connecting points (1) align or until the load has been removed from the pins; *▶ Derricking the lattice extension, p. 3 - 91.*

52203182

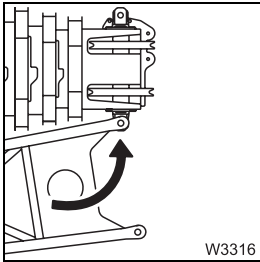
3.6.10**Swinging the lattice extension onto the main boom head**

This section describes slewing the lattice extension

- onto the main boom head when rigging and
- onto the main boom basic section when removing.

The lattice extension must be swung out of the transport position **onto** the main boom head so that section 1 can be fastened to the right side of the main boom head with pins.

Prerequisites

- The lattice extension is in transport position when the lattice extension is folded at the side; ■■■▶ p. 3 - 16.
- The connection is established in the *Front* area; ■■■▶ p. 3 - 46.
- In the *Rear* area, either the connection between section 2 and the main boom **or** between section 1 and section 2 will be released depending on the swing-away lattice extension required; ■■■▶ p. 3 - 53.
- The connection in the *Middle* area is in the position required for the necessary swing-away lattice extension; ■■■▶ p. 3 - 51.

**Risk of accidents from a falling lattice extension**

Ensure that the connection in the *Front* area has been established before you swung the lattice extension onto the main boom head.

This will prevent the lattice extension from falling as it is turned and causing injury to you or other persons.

Swinging the lattice extension

Only swing the lattice extension when all the prerequisites names have been fulfilled.

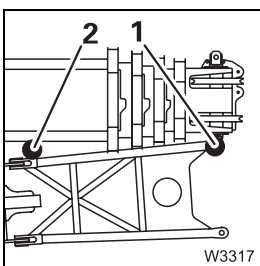

When swung, the lattice extension rolls on the run-up rail, rotates around the slewing axis (2) in the *Front* area and makes contact at the front at the connecting points (1).



- When **rigging**, pull the lattice extension away at the back from the basic section until it makes contact at the front and the bearing points (1) are aligned.
- When **unrigging**, push the lattice extension at the back on the run-up rail onto the main boom, until it engages with the slewing axis, and insert the pin; ■■■▶ *Establishing a connection*, p. 3 - 47.

3.6.11

Swinging the lattice extension when rigging

When rigging – section 1

When rigging the 12 m (39 ft) or 21 m (69 ft) swing-away lattice extension, you must swing section 1 in front of the main boom head.



- Check that the following conditions are met:
 - The connection on the right-hand side of the main boom is established;  p. 3 - 61.
 - The lattice extension is secured with a guide rope at the front of section 1;  p. 3 - 32.
 - Those connections have been released which must be released for the currently mounted lattice extension according to the checklist *CHECK-LIST: Rigging the 12/21 m (39/69 ft) swing-away lattice extension*;  p. 3 - 20, point 9. to point 14.



Risk of accidents from lattice extension swinging of its own accord

Always secure the lattice extension with a guide rope before swinging it. Make sure that there are no people or objects in the slewing range of the lattice extension and always swing the lattice extension from the ground using a guide rope.

For hydraulically derricked lattice extensions

- Carefully raise the lattice extension completely using the hand control from the ground;  p. 3 - 91.
 - When the holder (2) on section 1 is now completely retracted from the slewing axis (1), the lattice extension will begin to swing.
 - If the holder (2) still reaches into the slewing axis (1), you must release the connection in the *Front* area;  p. 3 - 48.

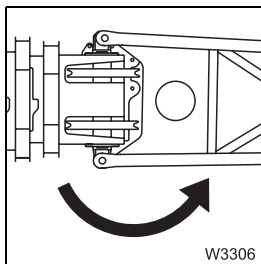
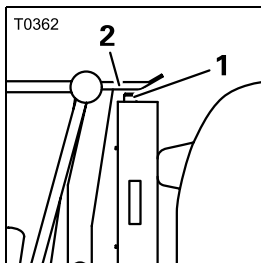

If a helper is holding the guide rope, they can now swing the lattice extension in front of the main boom head.

If you are alone and have attached the guide rope to the crane when securing, the lattice extension now swings only until the guide rope is tight. You can now swing the lattice extension in front of the main boom head using with the guide rope.



You may need to trigger the swinging procedure by pulling on the guide rope.



When unrigging – section 1

When unrigging the 12 m (39 ft) or 21 m (69 ft) swing-away lattice extension, you must swing section 1 to the side of the main boom.



Risk of accidents from lattice extension swinging of its own accord

Always secure the lattice extension with a guide rope before swinging it. Make sure that there are no people or objects in the slewing range of the lattice extension and always swing the lattice extension from the ground using a guide rope.

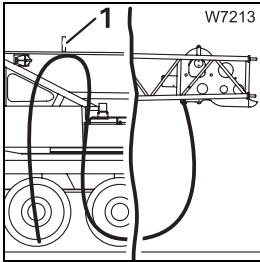

- Fasten a guide rope at the front of section 1 and lay the guide rope over the clamp (1) at the rear of the main boom.
- In the *Front* area, check whether the slewing axis is in the position for unrigging; ■■■▶ p. 3 - 50.

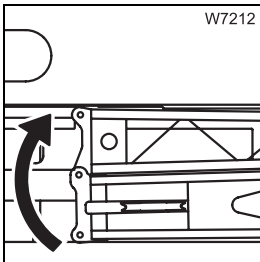

- Swing the lattice extension to the side of the main boom.
- **For hydraulically derricked lattice extensions**
 - Lower the lattice extension until it is resting on the run-up rail.

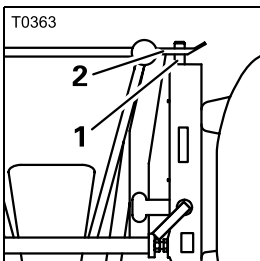

- Pull the lattice extension far enough toward the main boom for the holder (2) to reach into the slewing axis (1).
- In the *Front* area, insert the pin (1) and secure it with the retaining pin; ■■■▶ p. 3 - 47.



When rigging – section 2

When rigging the 21 m (59 ft) swing-away lattice extension, you must swing section 2 in front of section 1 as well.



Risk of accidents through section 2 swinging of its own accord

Always secure section 2 with a guide rope before you release the connection between section 1 and section 2 and only position the ladder on the left at section 1.

In this way you prevent part 2 from swinging round of its own accord when the connection is released and knocking you off the ladder.

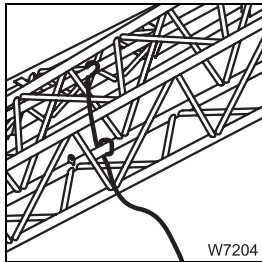

- Fasten a guide rope to the front at section 2.
- Secure section 2 against swinging round.
Get a helper to hold the guide rope taut, or fasten it to the bottom of section 1.

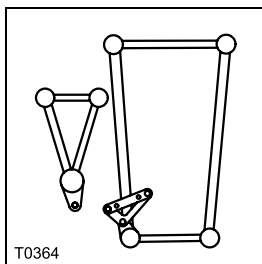

- In the *Middle* area, move the connection into the position *Section 1/ main boom*;  p. 3 - 52.



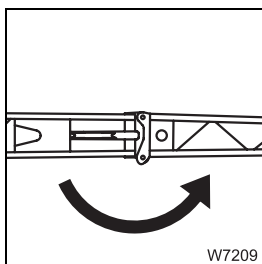

Risk of accidents through section 2 swinging round

Make sure that there are no people or objects in the slewing range of the lattice extension and always swing the lattice extension from the ground using a guide rope.

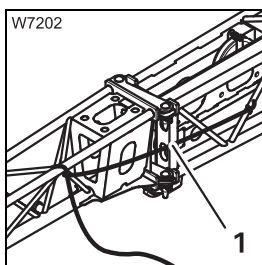

- Swing section 2 in front of section 1 using the guide rope.
- Secure section 2 against swinging round.
Get a helper to hold the guide rope taut.



- If you are working alone, secure section 2 from swinging round on the left-hand side at section 1 using a second guide rope (1).
- Establish the left-hand connection between section 2 and section 1;
 *Establishing a connection*, p. 3 - 70.



When unrigging – section 2

When unrigging the 21 m (69 ft) swing-away lattice extension, you must swing section 2 to the side of section 1.



Check that the electrical connection between section 1 and section 2 is broken before you swing section 2 towards section 1. It is difficult to reach the electrical connection after section 2 has been swung round.

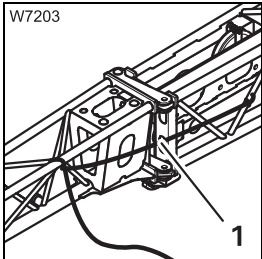

- Secure section 2 against swinging round.
Get a helper to hold the guide rope taut.
- If you are working alone, secure section 2 from swinging round on the left-hand side at section 1 using a second guide rope (1).
- Release the left-hand connection between section 2 and section 1;
 ■■■► *Releasing the connection*, p. 3 - 71.



Risk of accidents through section 2 swinging round

Make sure that there are no people or objects in the slewing range of the lattice extension and always swing the lattice extension from the ground using a guide rope.

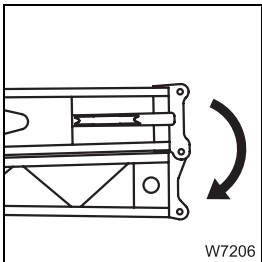

- Swivel section 2 to the side of section 1 using the guide rope.



Risk of accidents through section 2 swinging of its own accord

Always secure section 2 with a guide rope before you establish the connection between section 1 and section 2 and only position the ladder on the left at section 1.

In this way you prevent part 2 from swinging round of its own accord and knocking you off the ladder.

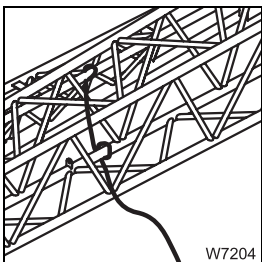

- Secure section 2 against swinging round.
Get a helper to hold the guide rope taut, or fasten it to the bottom of section 1.

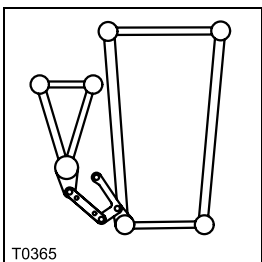



- In the *Middle* area, move the connection into the position *Section 1/section 2*; ■■■► p. 3 - 51.

3.6.12

Establishing/releasing connections on the lattice extension

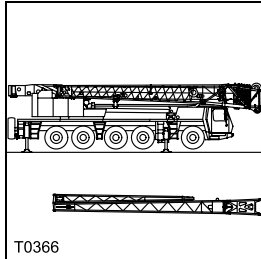
The procedure for establishing and releasing the connections between section 1 and section 2 depends on the transport condition of the sections.



- When section 1 and section 2 are folded up on the side for transportation, you only need to establish and release the connection on the left-hand side;  *Section 1 and section 2 installed*, p. 3 - 70.

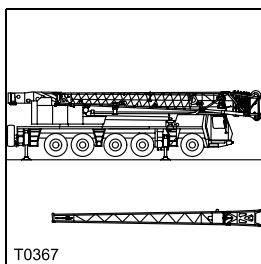

- If only section 1 is folded up on the side for transportation and section 2 is removed for transportation, you must establish and release the connections on both sides;  *Only section 1 installed*, p. 3 - 72.



Risk of accidents due to falling parts

Always secure the pins both in the connecting points and in the holders using retaining pins. This prevents unsecured pins from becoming loose, falling out and causing injuries.



Section 1 and section 2 installed

This section presupposes that section 1 and section 2 are folded up on the side of the main boom for transportation.



Risk of accidents through section 2 swinging of its own accord

Always secure section 2 with a guide rope and only position the ladder on the left of section 1. In this way you prevent part 2 from swinging round of its own accord and knocking you off the ladder.



If necessary you can relieve the strain on the connecting points in a similar manner by setting down section 2 on the ground or raising it; ►► *Relieving the connecting points*, p. 3 - 63.

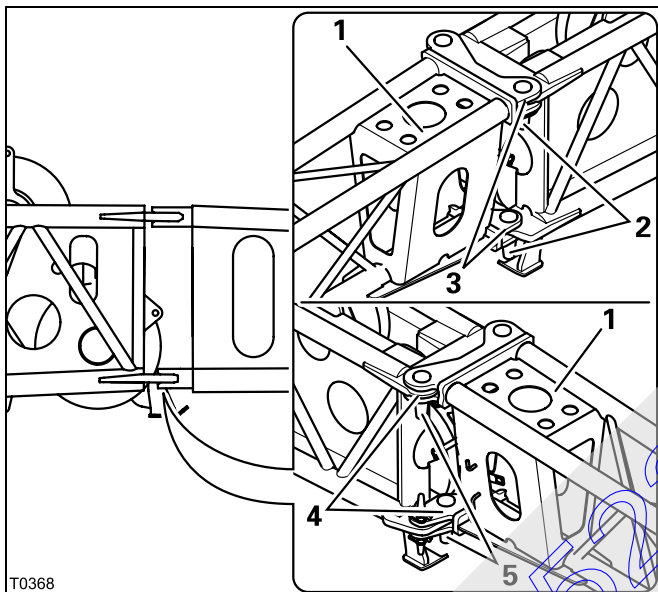

Establishing a connection

The connection is established after section 2 is slewed in front of section 1.

- Remove the retaining pins and remove the pins (2) from the retaining sheet (1).
- Insert the pins (2) into the connecting points (3).
- Secure the bolts using retaining pins.
- Loosen the retaining pin and remove the pin (5) from the retaining sheet (1).
- Insert the pin (5) into the connecting point (4).
- Secure the pin with the retaining pin.



Risk of accidents from a falling lattice extension

Ensure that when the connection between section 1 and section 2 has been made, that **three pins** have been inserted on the right-hand side. The thin pin is not designed to withstand the load during operation. The lattice extension will fall down when the thin pin breaks. This may lead to injury and even death to yourself or other people.

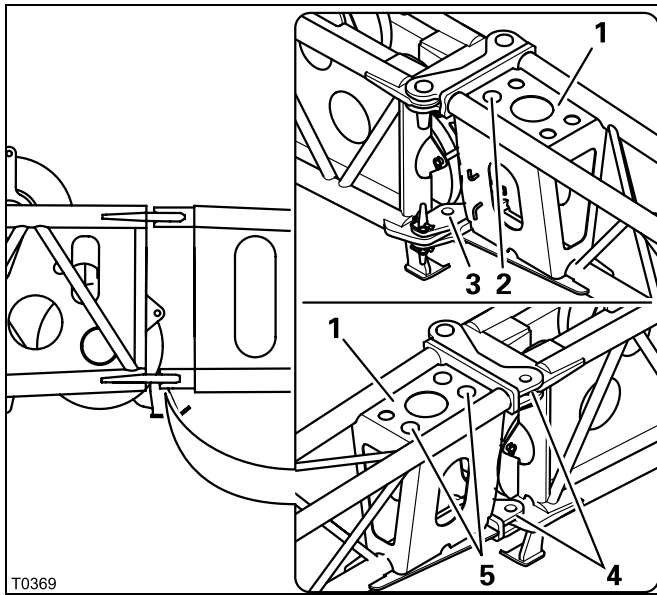

Releasing the connection

The connection is released before section 2 is folded onto the side of section 1.

- Loosen the retaining pin and remove the pin (2) from the connecting point (3).
- Insert the pins (2) into the retaining sheet (1).
- Remove the retaining pins and pull the pins (5) out of the connecting points (4).
- Insert the pins (5) into the retaining sheet (1).
- Secure the pins using the retaining pins.



52203182

Only section 1 installed

This section presupposes that section 1 is folded up on the side of the main boom and section 2 is removed for transportation.



Danger of crushing by swinging section 2

Always secure section 2 with a guide rope from the ground before establishing or releasing the connection.

In this way you prevent the swinging lattice extension from knocking you off the ladder, or you being crushed between the sections of the lattice extension.

- Fasten a guide rope to section 2.

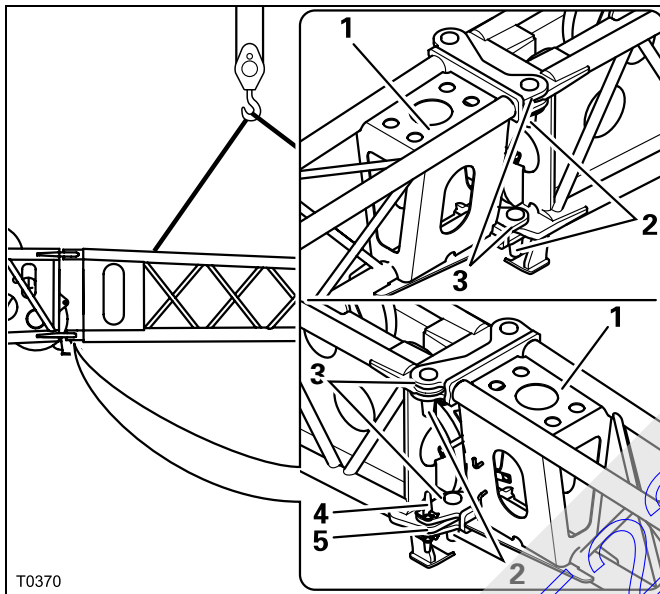

Establishing a connection

- Sling section 2 onto an auxiliary crane, centre of gravity; see p. 3 - 10.
- Remove the thin pin (4) from the connecting point (5). To do so, loosen the retaining pin.
- Position section 2 so that the connecting points (3) align.
- Insert the thin pin (4) into the connecting point (5) on the lower right.
- Secure the pin (4) with a retaining pin.
- Remove the retaining pins and remove the pins (2) from the retaining sheet (1).
- Insert the pins (2) into the connecting points (3) on both sides.
- Secure all pins (2) with retaining pins.

T0370

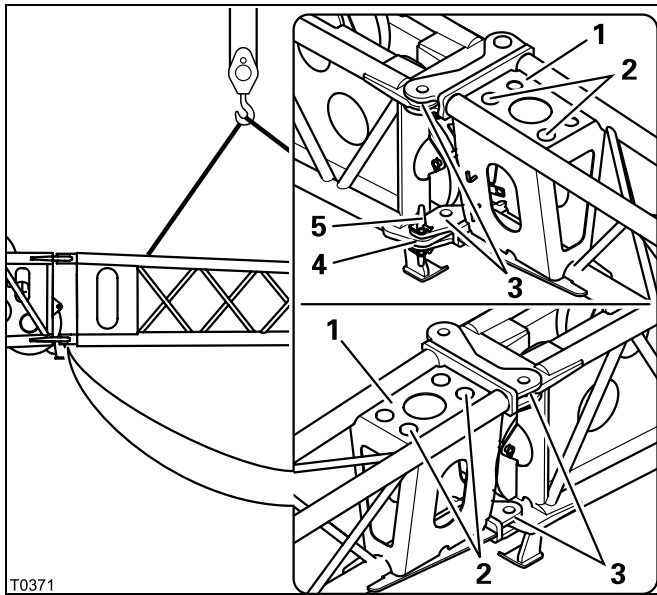

Releasing the connection

- Sling section 2 onto an auxiliary crane, centre of gravity; ► p. 3 - 10.
- Remove the retaining pins and pull the pins (2) out of the connecting points (3) on both sides.
- Insert the pins (2) into the retaining sheet (1).
- Secure the pins into place using the retaining pins.
- Loosen the retaining pin and remove the pin (5) from the connecting points (4).
- Lift section 2 from section 1.
- Insert the pin (5) back into the connecting point (4).

52203182

3.6.13

Electrical connections on the lattice extension

The SLI, the lifting limit switch and the anemometer are connected via the electrical connection on the lattice extension.



Danger of becoming trapped due to swinging lattice extension

Start the subsequent work only if the lattice extension is locked in front of the main boom head or it is secured against swinging around.

This will prevent the lattice extension from swinging inadvertently to the side of the main boom and possibly crushing you.

On 12 m (39 ft) swing-away lattice extension

For the **12 m (39 ft)** swing-away lattice extension the electrical connection is made or disconnected on the right side of the main boom head.

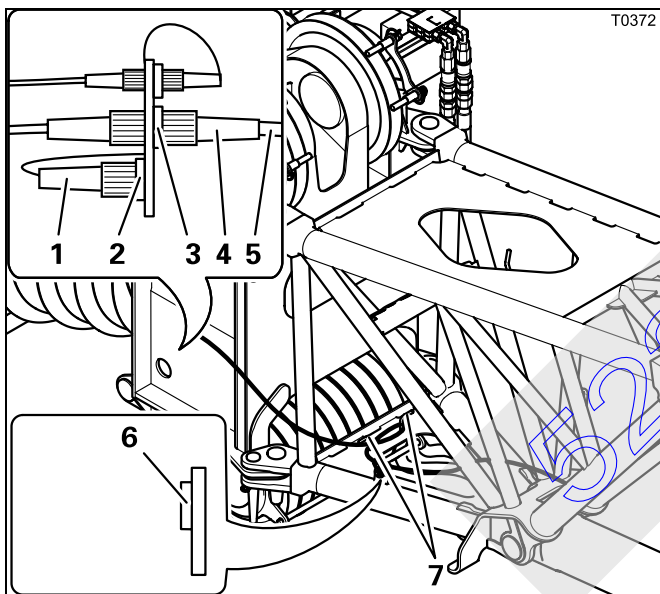

Establishing an electrical connection

- Remove the bridging plug (1) from the socket (3) and plug it into the dummy socket (2).
- Unwind the cable (5) from the holder (7).
- Remove the bridging plug (4) from the dummy socket (6) and plug it into the socket (3).
- Wind up the cable (5) far enough on the clamp (7) so that it does not hang down.

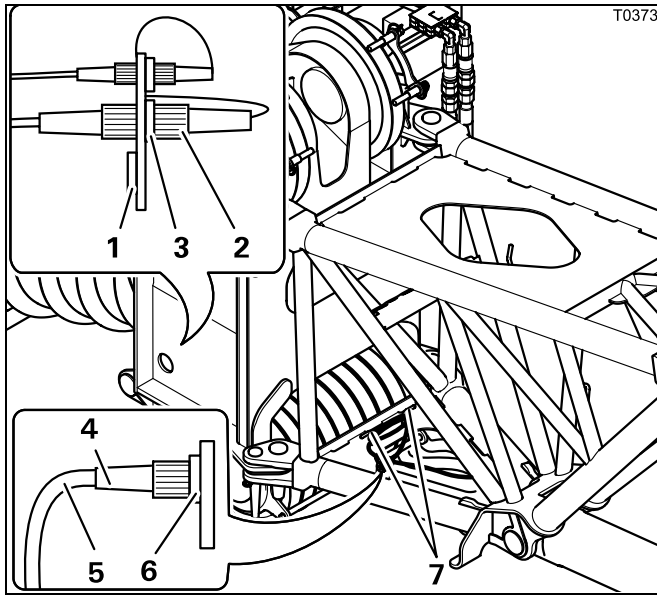

Disconnecting the electrical connection

- Remove the plug (4) from the socket (3) and plug it into the dummy socket (6).
- Wind the cable (5) onto the holder (7).
- Remove the bridging plug (2) from the dummy socket (1) and plug it into the socket (3).

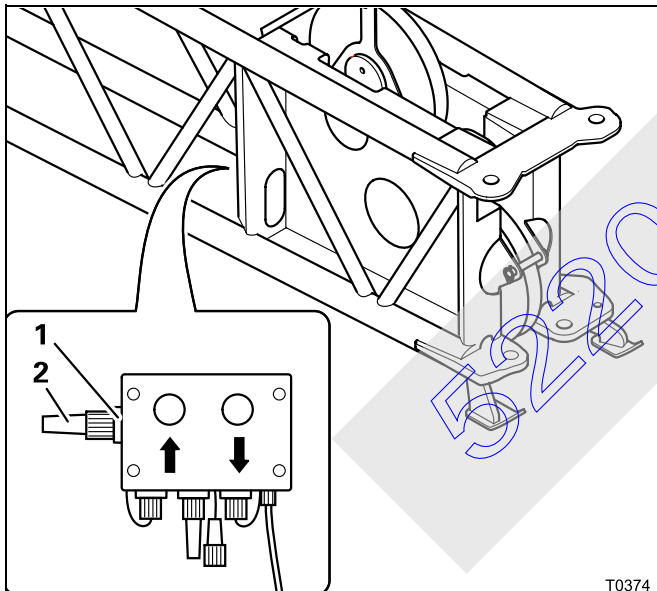

- Check whether the bridging plug (2) is inserted into the socket (1) at the front on section 1.



**On 21 m (69 ft)-
swing-away lat-
tice extension**

For the 21 m (69 ft) swing-away lattice extension, a further connection must be established or released between section 1 and section 2 in addition to that made for the electrical connection of the 12 m (39 ft) swing-away lattice extension.

- First make the electrical connection for the 12 m (39 ft)m swing-away lattice extension; ■■■► p. 3 - 74.

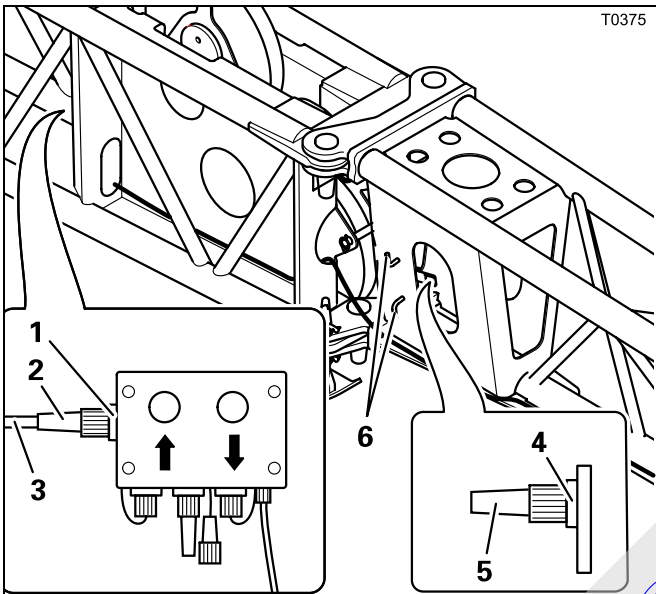

Establishing the electrical connection

- Remove the plug (5) from the socket (1) and plug it into the dummy socket (4).
- Unwind the cable (3) from the holder (6).
- Remove the plug (2) from the dummy socket (4) and plug it into the socket (1).
- Wind up the cable (3) far enough on the clamp (6) so that it does not hang down.

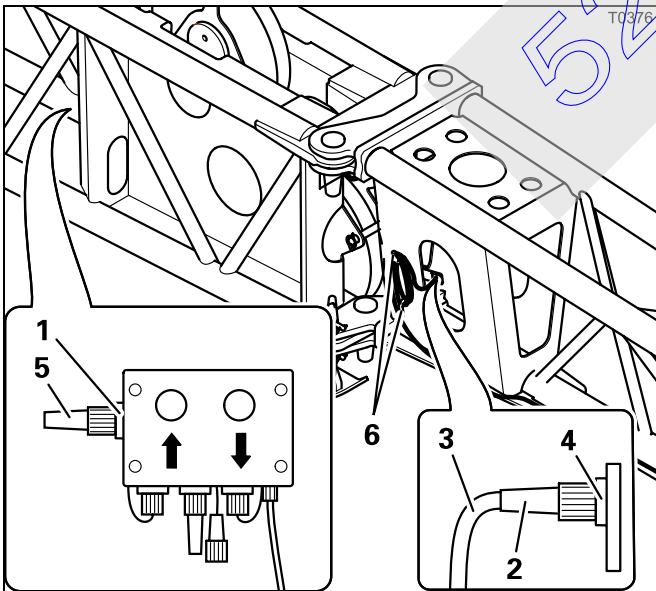

Disconnecting the electrical connection

- Remove the plug (2) from the socket (1) and plug it into the dummy socket (4).
- Wind the cable (3) onto the holder (6).
- Remove the plug (5) from the dummy socket (4) and plug it into the socket (1).

3.6.14

Folding deflection sheave out/in

To prevent the hoist rope dragging on the main boom or lattice extension during operation with the lattice extension or boom extension, the hoist rope is guided via deflection sheaves. On section 1 there is a hinged deflection sheave at both the front and the rear.

Folding out the deflection sheaves

To work with the lattice extension or the boom extension, both deflection sheaves must be folded out.



Danger of accidents by exceeding the permitted overall height!

Always fold in the deflection sheaves when the lattice extension is folded onto the side of the main boom for driving. When the deflection sheaves are folded out, the overall height specified for on-road driving is exceeded.



Risk of crushing.

When you pull out the pins, always keep a firm grip on the *Rear deflection sleeve* with the handle, and keep a firm grip on the *Front deflection sheave* at the strut.

Your fingers might get crushed if you hold the sheave by the side plate.

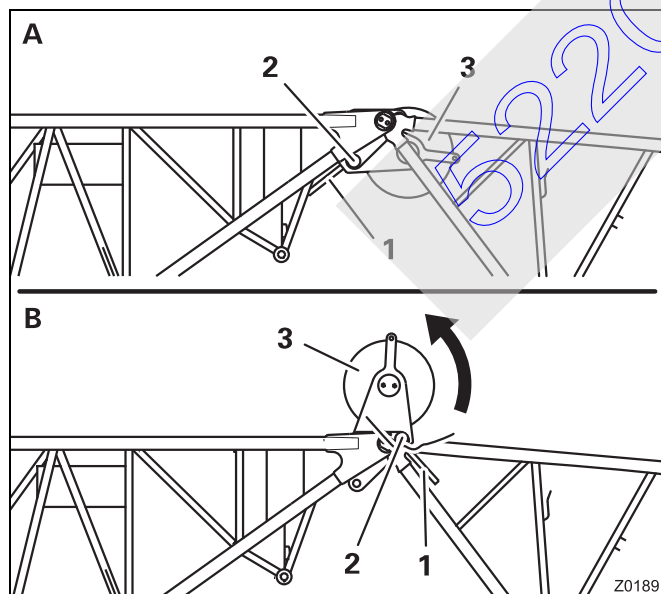

Rear deflection sheave

- **(A)** – Unscrew the retaining pin from the pin **(2)**.
- Hold the deflection sheave by the handle **(1)** and pull out the pin **(2)**.
- **(B)** – Fold the deflection sheave **(3)** upwards and fasten it in this position with the pin **(2)**.
- Secure the pin **(2)** using the retaining pin.



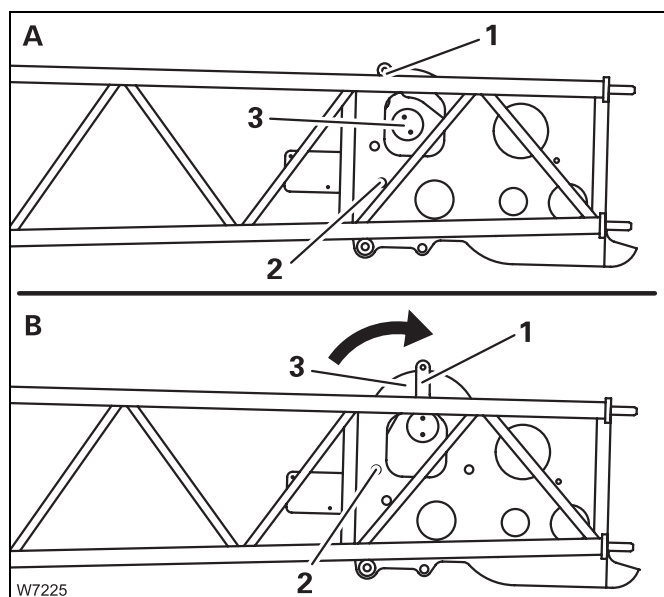

Front deflection sheave

- **(A)** – Unscrew the retaining pin from the pin (2).
- Hold the deflection sheave by the strut (1) and pull out the pin (2).
- **(B)** – Fold the deflection sheave (3) upwards and fasten it in this position with the pin (2).
- Secure the pin (2) using the retaining pin.

52203182

Folding in the deflection sheaves

For transportation you must fold in the deflection sheaves.



Danger of accidents by exceeding the permitted overall height!

Always fold in the deflection sheave when the lattice extension is folded onto the side of the main boom for driving. When the deflection sheave is folded out, the overall height specified for on-road driving is exceeded.



Risk of crushing

When you pull out the pins, always keep a firm grip on the *Rear deflection sleeve* with the handle, and keep a firm grip on the *Front deflection sheave* at the strut.

Your fingers might get crushed if you hold the sheave by the side plate.

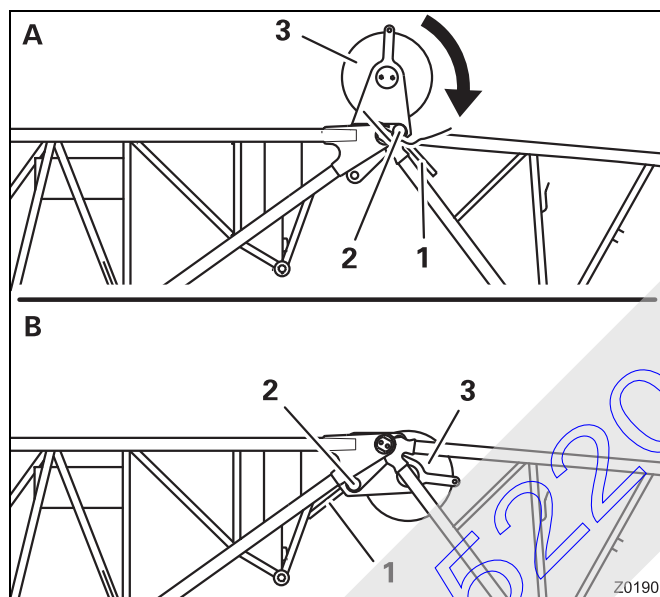

Rear deflection sheave

- (A) – Unscrew the retaining pin from the pin (2).
- Hold the deflection sheave by the handle (1) and pull out the pin (2).
- (B) – Fold the deflection sheave (3) downwards and fasten it in this position with the pin (2).
- Secure the pin (2) using the retaining pin.

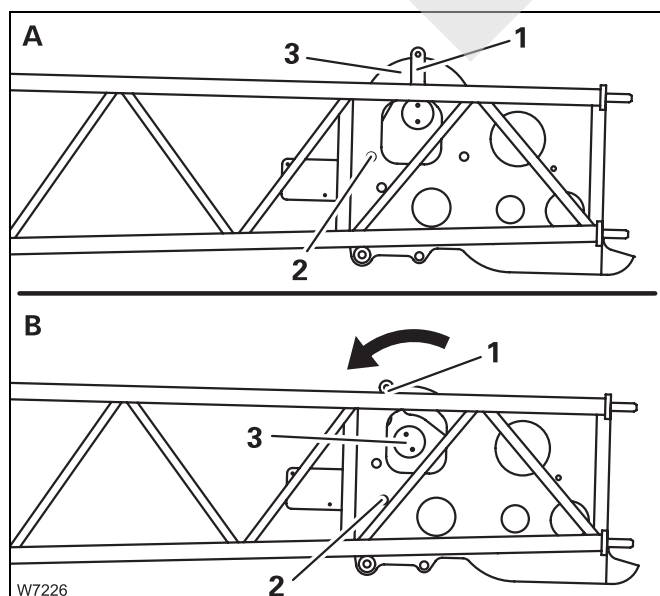

Front deflection sheave

- (A) – Unscrew the retaining pin from the pin (2).
- Hold the deflection sheave by the strut (1) and pull out the pin (2).
- (B) – Fold the deflection sheave (3) downwards and fasten it in this position with the pin (2).
- Secure the pin (2) using the retaining pin.

3.6.15

Positioning/removing the hoist rope



Risk of accidents due to falling parts

Always secure the hoist rope holding rollers and rods with retaining pins. This prevents elements from coming loose, falling down and injuring people.

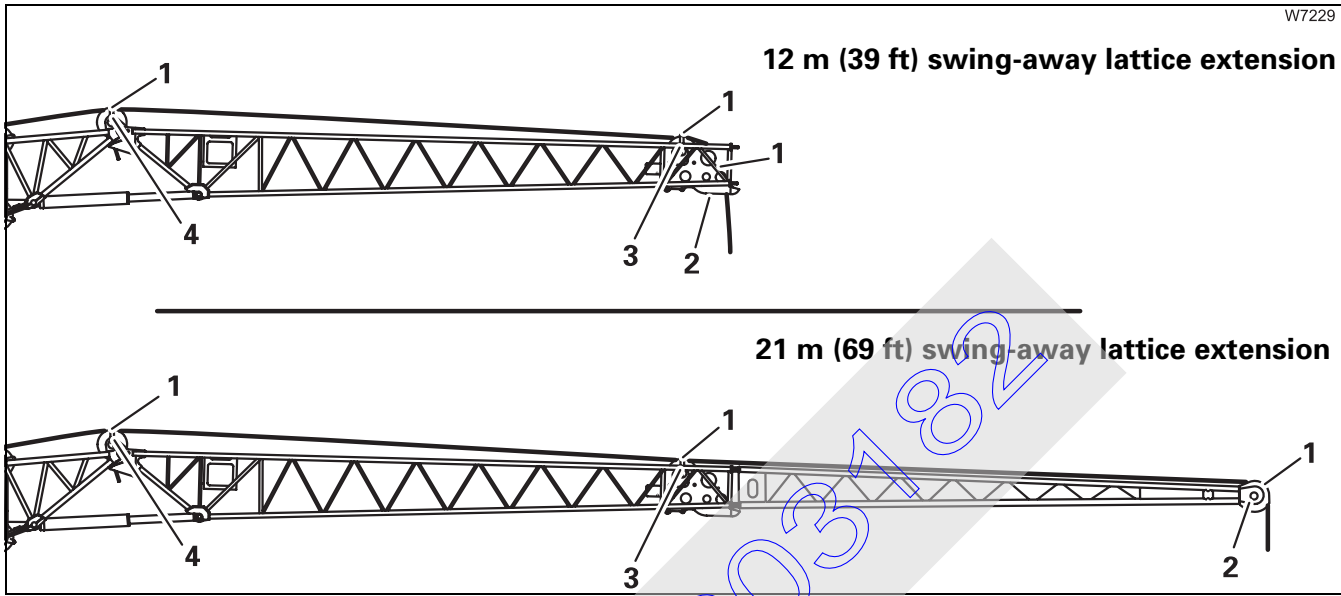

Positioning the hoist rope

- Remove the hoist rope holding rollers (1).
- Guide the hoist rope over the deflection sheaves (4), (3) and over the head sheave (2) to section 1 or section 2.
- Put all hoist rope holding rollers (1) back in place and secure them with retaining pins.
- Install the hook tackle or the hook block. The hoist rope may now be reeved once or twice, depending on the length of lattice extension;  p. 3 - 81.

Removing the hoist rope

- Unreeve the hook block.
- Remove the hoist rope holding rollers (1).
- Take the hoist rope off the head sheave (2) and the deflection sheaves (4), (3) and place it onto the ground on the left side.
- Put all hoist rope holding rollers back in place and secure them with retaining pins.

Possible reeving methods on the lattice extension

The hoist rope can be reeved a maximum of two falls on the 12 m (39 ft) swing-away lattice extension.
 The hoist rope can be reeved only one fall on the 21 m (69 ft) swing-away lattice extension and on the boom extension.



1-sheave hook block
 Maximum lifting capacity of the hook block 32 t (70 500 lbs)
Maximum load bearing capacity with the GMK 5220:

A For reeving 1-fall	9.5 t (20 900 lbs)
B For reeving 2-falls	19.0 t (41 800 lbs)

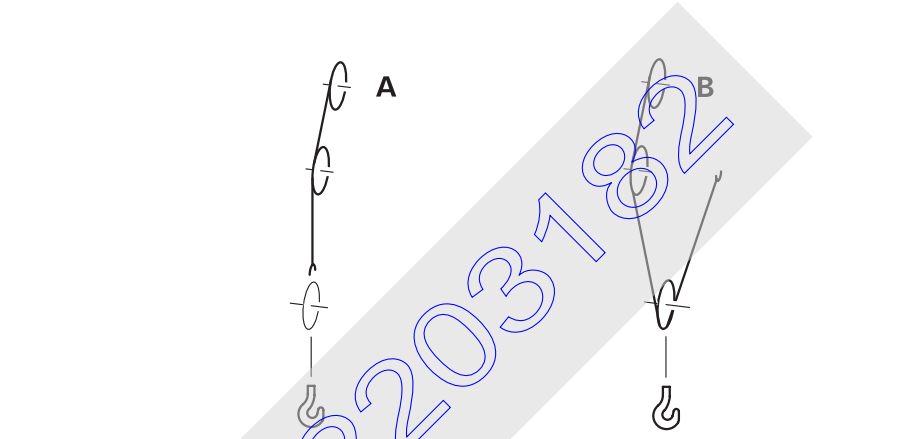



Hook tackle
 Maximum lifting capacity of the hook tackle 12 t (26 600 lbs)
Maximum load bearing capacity with the GMK 5220:

A For reeving 1-fall	9.5 t (20 900 lbs)
-----------------------------	--------------------



W6601

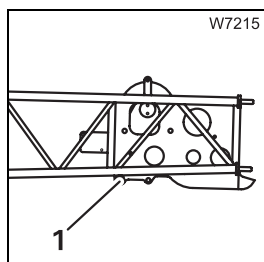

- With a 2-fall reeving, fasten the rope end clamp to the attachment plate (1) at the front on section 1.

3.6.16

Installing/removing the lifting limit switch

The functions *Raise hoist*, *Extend main boom*, *Lower main boom* and, with hydraulically derricked lattice extension, *Derrick lattice extension* are monitored during operation with the lattice extension by the lifting limit switch on the lattice extension and are switched off when the lifting limit switch is actuated.



The same lifting limit switch can be used for the lattice extension and the main boom. If two lifting limit switches are supplied as additional equipment, one lifting limit switch can stay connected to the main boom. This lifting limit switch must then be disabled, however.

Overriding connection on main boom

For operation with the lattice extension you must remove the lifting limit switch from the main boom and then bridge the connection. Connection points are available on both the right and left hand sides.

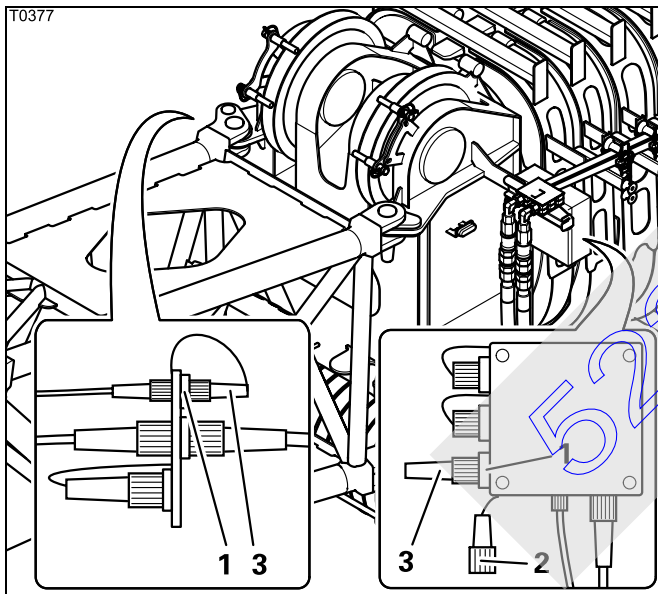

On the left side:

- Remove the bridging plug (3) from the dummy socket (2) and plug it into the socket (1).

On the right side:

- Insert the bridging plug (3) into the socket (1).

The connections are now bridged.



If a lifting limit switch remains connected to the main boom head, you must disable this lifting limit switch; ► *Operating instructions GMK 5220 – Lifting limit switch.*

On 12 m (39 ft) swing-away lat- tice extension

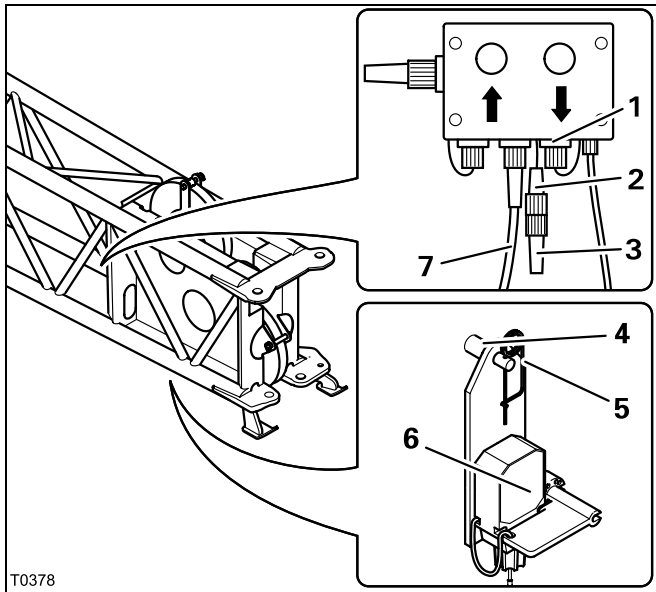

T0378

Connecting the lifting limit switch

- Release the retaining pin (5) and place the holder with the lifting limit switch (6) on the grip (4) on section 1.
- Secure the holder with the retaining pin (5).
- Remove the plug (3) from the socket (1) and plug it into the dummy socket (2).
- Lay the connecting cable (7) in such a way that it is not damaged during crane operation.
- Insert the plug of the connecting cable (7) into the socket (1).

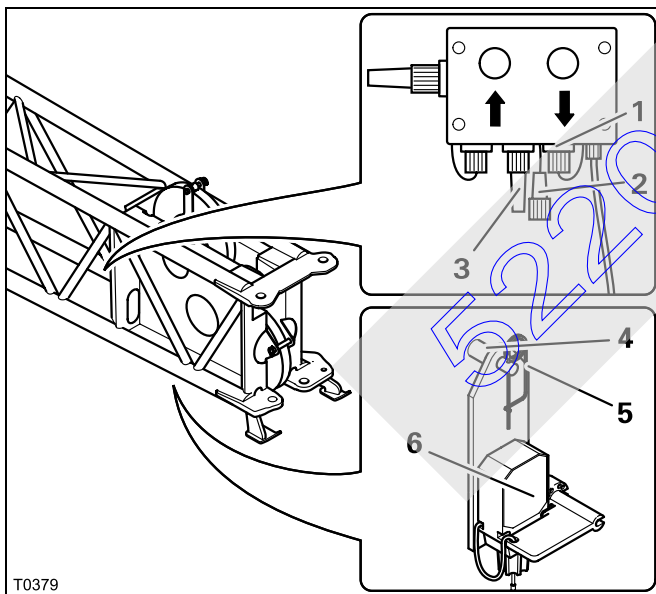

T0379

Removing the lifting limit switch

- Pull the plug of the connecting cable of the lifting limit switch out of the socket (1).
- Remove the plug (3) from the dummy socket (2) and plug it into the socket (1).
- Loosen the retaining pin (5) and remove the holder with the lifting limit switch (6) from the grip (4).
- Attach the retaining pin to the holder of the lifting limit switch.



**On 21 m (69 ft)
swing-away lat-
tice extension**

This section also applies when the boom extension is rigged.

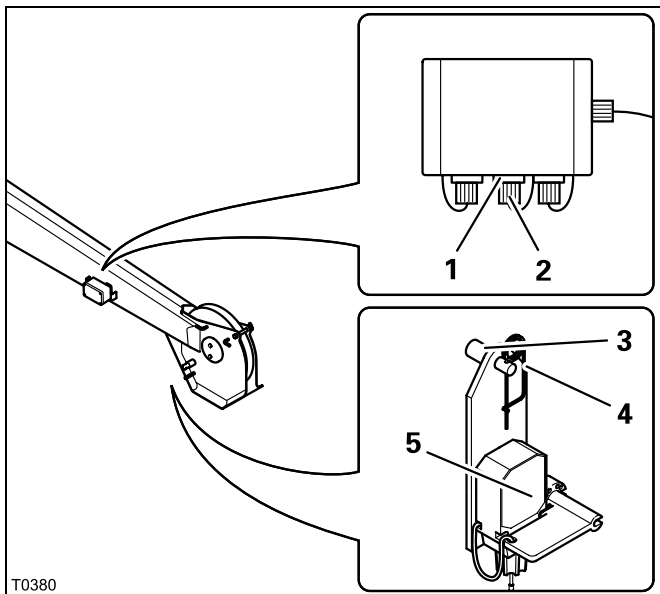

Connecting the lifting limit switch

- Loosen the retaining pin (4) and place the holder with the lifting limit switch (5) on the grip (3) on section 2.
- Secure the holder with the retaining pin (4).
- Lay the connecting cable (3) in such a way that it is not damaged during crane operation.
- Insert the plug of the connecting cable (2) into the socket (1).
- Check that the electrical connection to section 2 has been created at the front on section 1; *Establishing the electrical connection, p. 3 - 76.*

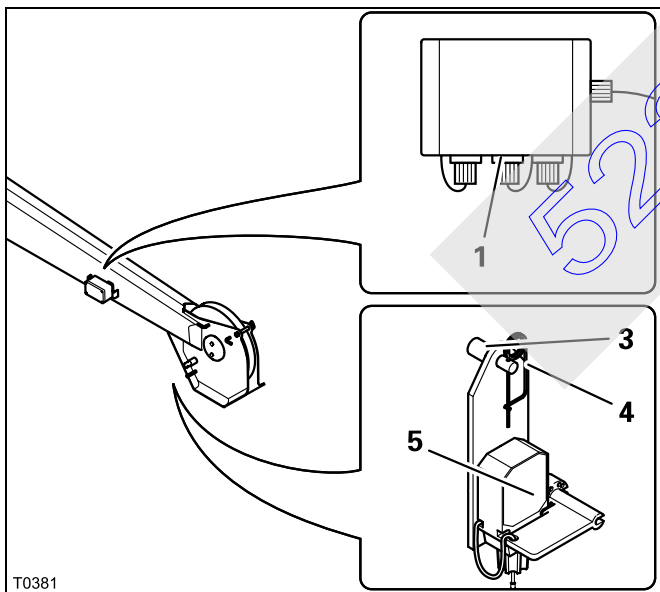

Removing the lifting limit switch

- Pull the plug of the connecting cable of the lifting limit switch out of the socket (1).
- Cover the socket (1) with the protective cap.
- Undo the retaining pin (4) and remove the holder with the lifting limit switch (5) from the holding rod (3).
- Attach the retaining pin (4) to the holder of the lifting limit switch.

3.6.17 Installing/removing the anemometer

**On 12 m (39 ft)
swing-away lat-
tice extension**

The anemometer is mounted on a grip.

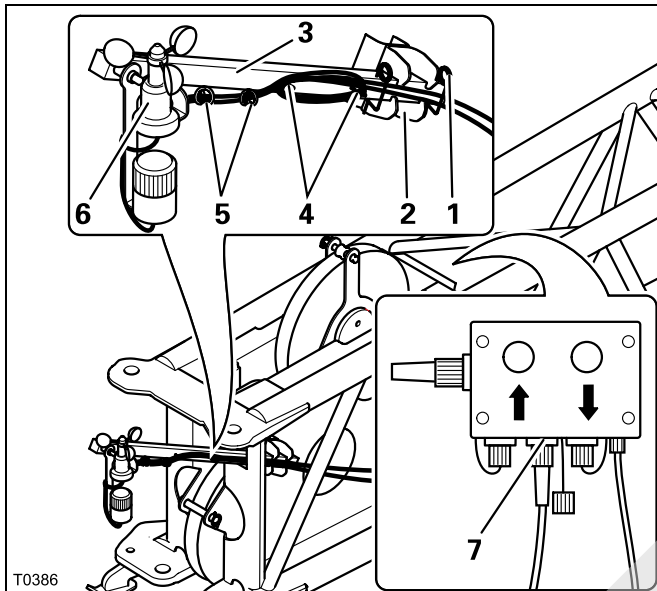

Mounting the anemometer

- Loosen the retaining pin (1).
 - Insert the grip (3) into the holder (2).
 - Secure the grip (3) using the retaining pin (1).
 - Check whether the cables restrict the anemometer (6) when swinging out. Swing out the anemometer (6) and let go of it. It must return to a vertical position after being swung out. The anemometer must also be suspended in a vertical position when the boom is raised.
 - Pull the cap off the socket (7).
 - Insert the plug of the anemometer into the socket (7).
- Position the connecting cable so that it will not be damaged during crane operation. Guide it through the clamp (5).
 - Wind any connecting cable which is hanging down onto the clamp (4).



Risk of damage to the anemometer

Remove the anemometer for on-road driving.

This prevents the anemometer from being damaged by wind (e.g. by suction currents caused by oncoming traffic in tunnels).



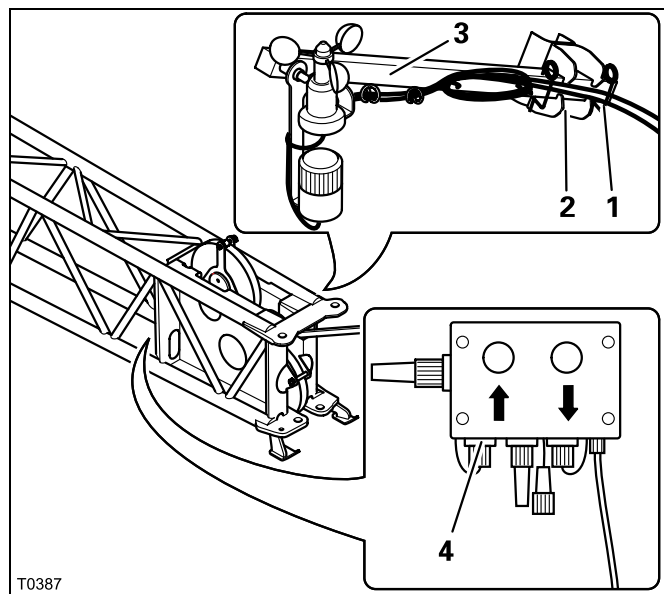

Removing the anemometer

- Pull the plug of the anemometer from the socket (4).
- Cover the socket (4) with the protective cap.
- Loosen the retaining pin (1).
- Pull the grip (3) out of the holder (2).
- Insert the retaining pin (1) into the grip.
- Securely stow away the grip (3) with the anemometer.

52203182

**On 21 m (69 ft)
swing-away
lattice extension**

This section also applies when the boom extension is rigged.

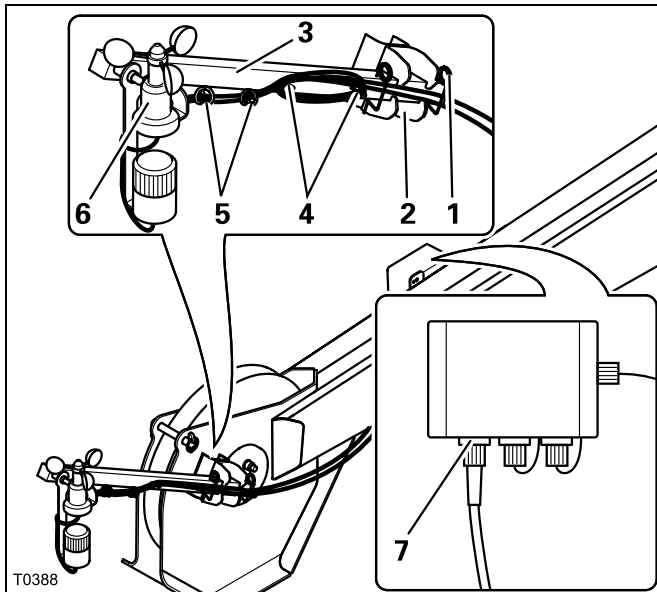

Mounting the anemometer

- Loosen the retaining pin (1).
 - Insert the grip (3) into the holder (2).
 - Secure the grip (3) using the retaining pin (1).
 - Check whether the cables restrict the anemometer (6) when swinging out. Swing out the anemometer (6) and let go of it. It must return to a vertical position after being swung out. The anemometer must also be suspended in a vertical position when the boom is raised.
 - Pull the cap off the socket (7).
 - Insert the plug of the anemometer into the socket (7).
- Position the connecting cable so that it will not be damaged during crane operation. Guide it through the clamp (5).
 - Wind any connecting cable which is hanging down onto the clamp (4).



Risk of damage to the anemometer

Remove the anemometer for on-road driving.

This prevents the anemometer from being damaged by wind (e.g. by suction currents caused by oncoming traffic in tunnels).



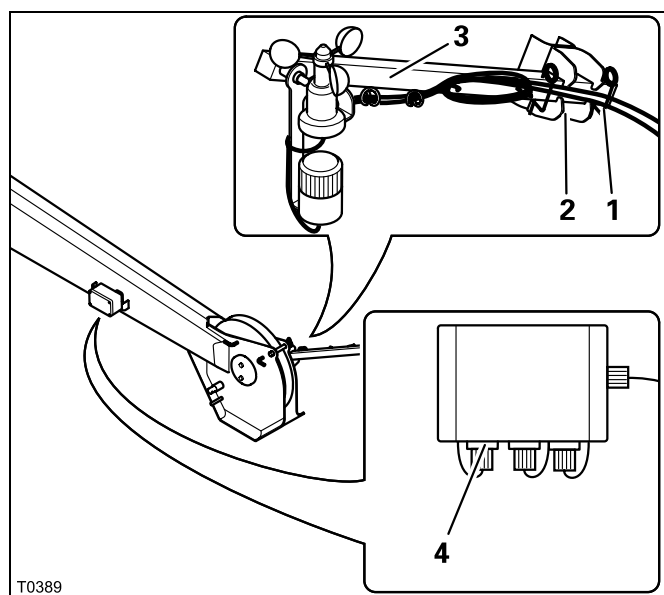

Removing the anemometer

- Pull the plug of the anemometer from the socket (4).
- Cover the socket (4) with the protective cap.
- Loosen the retaining pin (1).
- Pull the grip (3) out of the holder (2).
- Insert the retaining pin (1) into the grip.
- Securely stow away the grip (3) with the anemometer.

52203182

3.6.18

Air traffic control light – electrical connection

The air traffic control light (additional equipment) is mounted on the grip of the anemometer.

Establishing the electrical connection

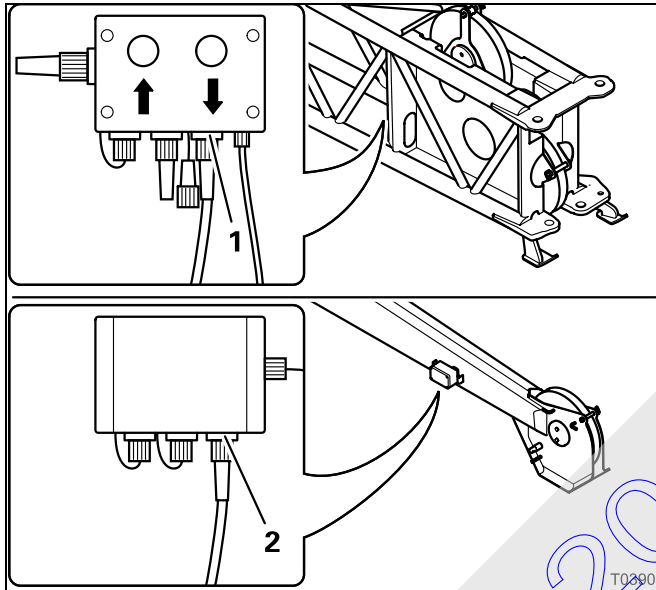

On 12 m (39 ft) swing-away lattice extension:

- Mount the anemometer; see p. 3 - 85.
- Loosen the protective cap on the socket (1).
- Insert the plug of the air traffic control light into the socket (1).

On 21 m (69 ft) swing-away lattice extension:

- Mount the anemometer; see p. 3 - 87.
- Loosen the protective cap on the socket (2).
- Insert the plug of the air traffic control light into the socket (2).

Switching on/off



You can switch the air traffic control light on and off from the crane cab with the *Air traffic control light on/off* rocker switch if you connect it to the electrical power supply.

To switch on: press the rocker switch downwards

To switch off: press the rocker switch upwards



Disconnecting the electrical connection



- Switch off the air traffic control light by pressing the top part of the *Air traffic control light on/off* rocker switch.

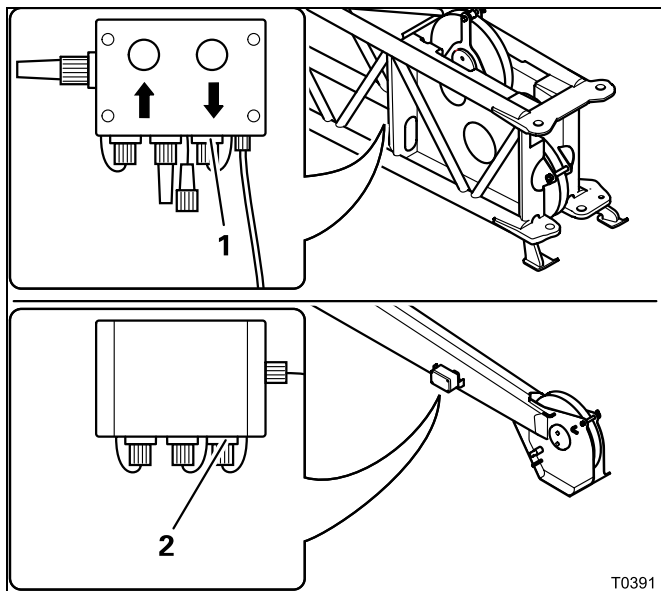

On 12 m (39 ft) swing-away lattice extension:

- Remove the plug of the air traffic control light from the socket (1).
- Cover the socket (1) with the protective cap.
- Remove the anemometer; see p. 3 - 86.

On 21 m (69 ft) swing-away lattice extension:

- Remove the plug of the air traffic control light from the socket (2).
- Cover the socket (2) with the protective cap.
- Remove the anemometer; see p. 3 - 88.

3.6.19

Derricking the lattice extension

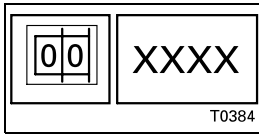

- Before derricking the lattice extension, enter an SLI code for working with the lattice extension so that derricking will be enabled;  *Setting*, p. 3 - 96.

When rigging

When rigging, you can control the derricking of the lattice extension using the button unit on section 1 or the hand-held control.

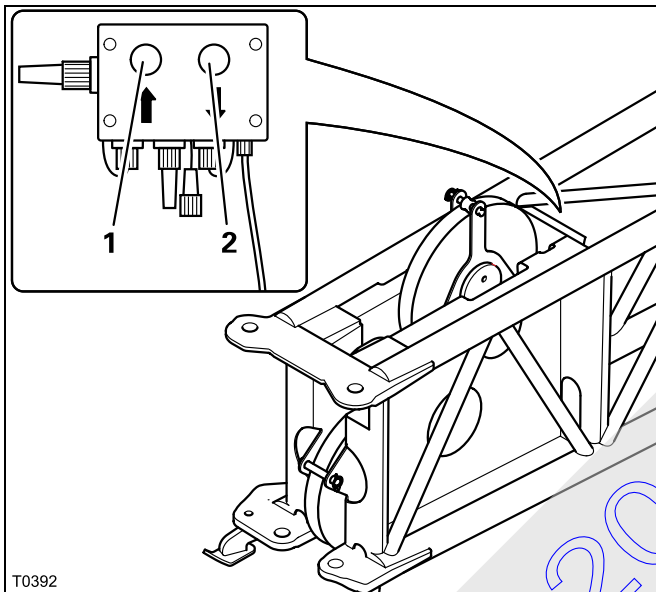

T0392

With the button unit on section 1

There is a button unit with two buttons on the front left side of section 1.

- To raise, press the *Raise lattice extension* push-button (1).
- To lower, press the *Lower lattice extension* push-button (2).

The lattice extension is lowered or raised as long as the corresponding push-button is pressed or until the end position or a switch-off point is reached.

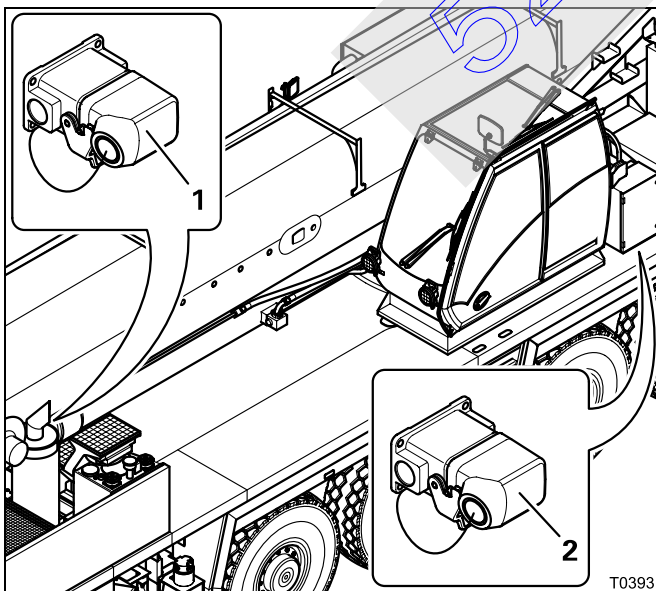

T0393

With the hand-held control

- Connect the hand-held control to the socket (1).

Connection to the socket (2) is not suitable for rigging since you cannot see the folded lattice extension from this point.

This socket (2) is intended for emergency operation.



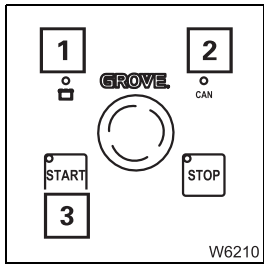

- Wait until the *CAN* (2) and *Charge control* (1) indicator lamps go on.

There is a malfunction if the *CAN* indicator lamp does not go on after approximately 20 seconds or if it flashes; *Operating instructions GMK 5220 – Malfunctions – Hand-held control.*

- Press the *START* (3) button; the diesel engine will start.
Release the button as soon as the diesel engine is running.

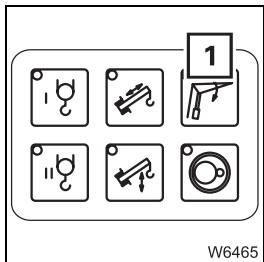

- Press in the preselection button *Raise lattice extension* (1) once.

The indicator lamp in the button lights up and you can derrick the lattice extension as described below using the buttons on the two-hand operating panel.

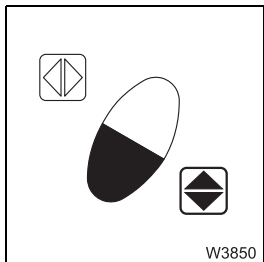

Raising

- Hold down the direction button and also press the *Left/down* movement button.

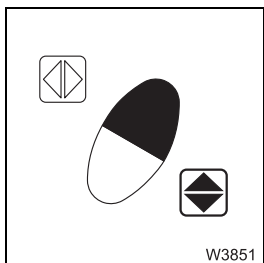

Lowering

- Hold down the direction button and also press the *Right/up* movement button.



The lattice extension is lowered or raised as long as the buttons are pressed or until the end position or a switch-off point is reached.

During operation

During operation the lattice extension is derricked from the crane cab. The lattice extension can be derricked only when the derricking gear for the lattice extension is switched on.

After turning on the ignition, all power units are switched off and the indicator lamps in the corresponding rocker buttons light up dimly.



- Switch on the lattice extension derricking gear.
Additionally, press the *Derricking gear on/off* rocker button down once.

When the derricking gear is switched on:



- the indicator lamp in the *Derrick lattice extension on/off* rocker button lights up brightly



- on the *Crane control* display in the main menu, the indicator lamp *Derrick lattice extension on/off* lights up in **green**.

All other power units to which the same control lever movement is assigned are now switched off (e.g. derricking gear and telescoping mechanism).

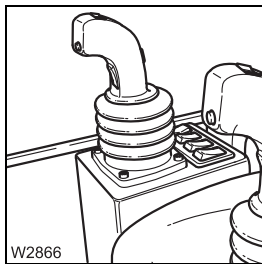

Raising

- Push the right-hand control lever to the **left**.

Lowering

- Push the right-hand control lever to the **right**.



The lattice extension is lowered or raised as long as the corresponding control lever is pushed in the corresponding direction or until the end position or a switch-off point is reached.

When the lattice extension is derricked, the SLI automatically switches to the values specified in the lifting capacity table for fixed angles (0° inclination) and intermediate angles (0 - 20° or 20 - 40° inclination) when this is permitted for the load currently being raised.

If this switchover is not permitted for the load currently raised, derricking will be switched off and a corresponding error message will be generated.

3.6.20**Transportation on a separate vehicle****Risk of accidents from a falling lattice extension**

Only attach the lattice extension in such a way that it is positioned in the centre of gravity and always use lifting gear with sufficient lifting capacity. This prevents the lattice extension falling and injuring people while loading;

- ▣▣▣▣▣ *Centres of gravity for slinging, p. 3 - 10,*
- ▣▣▣▣▣ *Transport dimensions and weights, p. 2 - 1.*

- Check if all the required connections for transport condition are established; ▣▣▣▣▣ *Transport condition with removed lattice extension, p. 3 - 37.*

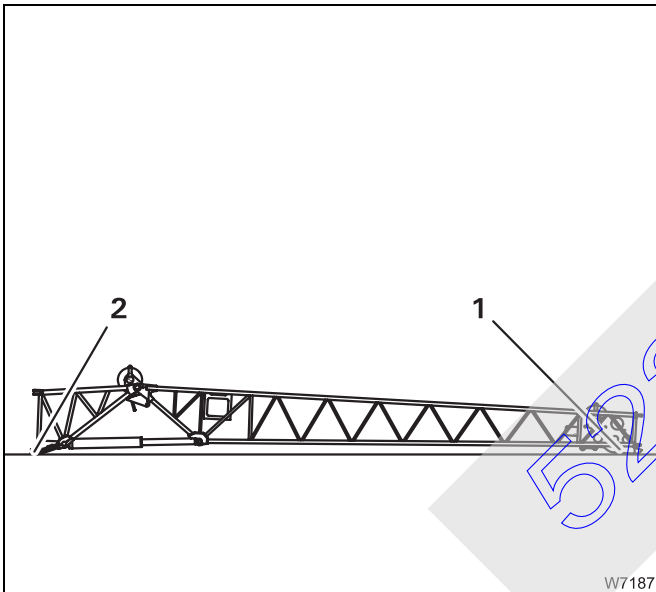

- For transportation, place the lattice extension on the skid (1) at the front and onto the lower connecting points (2) at the rear.
- Always secure the lattice extension on the separate vehicle with belts as well to prevent slipping and overturning.

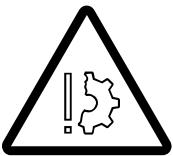
**Risk of damaging the lattice extension**

Always secure the lattice extension by tying it down with suitable belts when it is transported on a separate vehicle. This prevents the swing-away lattice extension tipping and becoming damaged during transportation.

3.7

Operation with the lattice extension



When operating the lattice extension, the maximum speed for the different power units is limited to 70%, *Operating instructions GMK 5220 – Crane operation – Adjusting power unit speeds.*



Risk of damage to main boom

During operation with the 12 m (39 ft) swing-away lattice extension with a 0° angle at the steepest boom position, the head sheaves at the main boom can be damaged when a hook block is raised or lowered.

Reduce the hoist speed so that the hook block is raised slowly passed the head sheaves.

The information in this section also applies to operation with the boom extension. Observe the following safety instruction before working with the boom extension.



Risk of overturning when working with the boom extension

No hook block may be reeved on the main boom during operation with the boom extension.

It is not permitted to work with the main boom if the boom extension is rigged.

The hoisting, lowering, slewing, derricking and telescoping movements are carried out in the same way as when operating with the main boom. This section only contains information that you will need for a rigged or installed lattice extension:

Setting, p. 3 - 96,

Telescoping with rigged lattice extension, p. 3 - 99,

Information about the SLI shutdown, p. 3 - 100,

Procedure if the permissible wind speed is exceeded, p. 3 - 101,

Information about the main boom operation when the lattice extension is folded/rigged, p. 3 - 102.

3.7.1 Setting



If a hook block is reeved on the main boom during operation with the lattice extension, the loads given in the *Lifting capacity tables* decrease and the SLI subsequently switches off earlier.

The values which must be deducted from the load capacities depend on the length of the lattice extension and the weight of the hook block. You will find a table with the values in the *lifting capacity tables* in the section *Information on working with the swing-away lattice extension*.

In the case of a hydraulically derricked lattice extension, the length of the lattice extension or boom extension is also given and displayed.

- Enter the current reeving at the SLI.
- Enter the current rigging mode on the SLI, either using the corresponding SLI code according to the *lifting capacity table* or using the individual components.
- Check whether the current rigging mode of the truck crane corresponds to the displayed rigging mode.

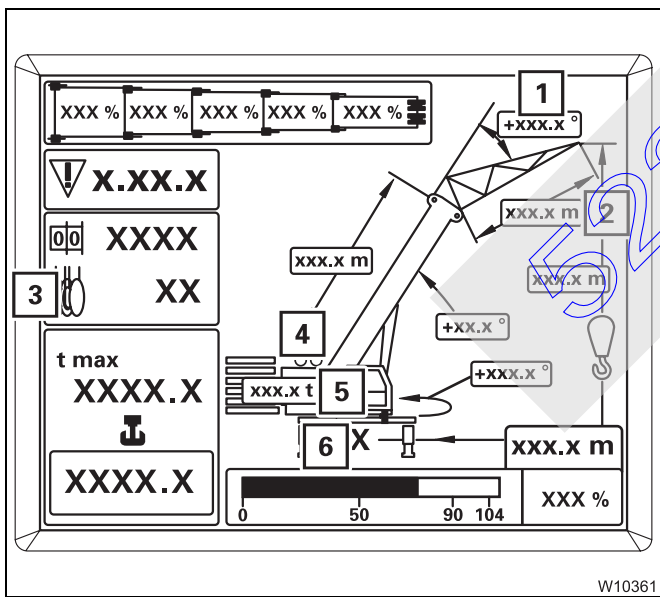

- Check:
 - 1 The angle of the rigged lattice extension (inclinable)
 - 2 The length of the rigged lattice extension
 - 3 The number of reeved rope lines
 - 4 The hoist which is switched on
 - 5 The rigged counterweight
 - 6 The rigged outrigger span

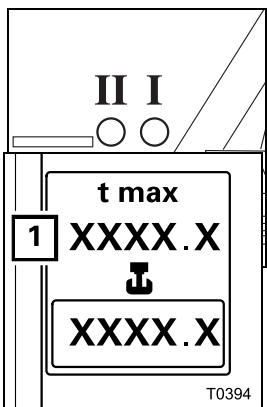

Hoist display

The light which goes on must always be for the hoist with which the load is to be lifted.

- Light I:** must go on if the load is to be raised with the main hoist.
- Light II:** must go on if the load is to be raised with the auxiliary hoist.

If the telescopic sections are mechanically locked, the SLI will now release

the load according to the *Lifting capacity table* and the *Maximum load display (1)* shows the corresponding value.

Only the value for the empty hook curve is released and shown when the telescopic sections are unlocked.

Depending on the current angle, the SLI automatically switches to the capacity diagrams for fixed angles (0° inclination) and intermediate angles (0 - 20° or 20 - 40° inclination) when this is permitted for the load currently being raised.

52203182

3.7.2

Raising and setting down the main boom



The information in this section also applies for raising and setting down the main boom with a rigged boom extension.

The following prerequisites must be fulfilled when raising and setting down the main boom:

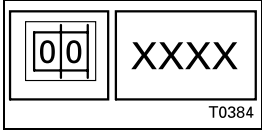

- The current rigging mode with the rigged lattice extension is set and the corresponding SLI code according to the *lifting capacity table* is displayed; *Setting*, p. 3 - 96.

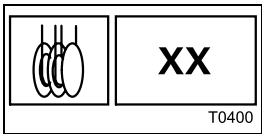

- The current reeving methods on the swing-away lattice extension is entered for the hoisting gear whose hoist rope is secured to the swing-away lattice extension.

- Apart from the hook block there is no load on the lattice extension.

- The main boom is fully retracted.

The SLI will only release the main boom for raising and setting it down when the main boom is completely retracted.

When all of the above prerequisites have been fulfilled, the SLI will automatically switch to the rigging tables and derricking can then be done in the angle range underneath the working range (less than approx. 15°).

You can find the rigging tables in the *lifting capacity tables*, in the chapter *Rigging tables - swing-away lattice extension*.

Raising

- Raise the main boom by derricking in.

Setting down

- Set down the main boom by derricking out.

3.7.3

Telescoping with rigged lattice extension

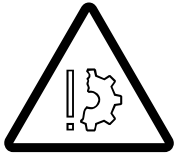

Risk of overloading the main boom

If you telescope the main boom with a rigged lattice extension or boom extension, you must not rotate the superstructure at the same time. This prevents the main boom being subjected to additional side forces and increased vibration and becoming overloaded.



Risk of damage to hydraulic hoses

Before telescoping with the hydraulically derricking lattice extension, check whether the locking device is released at the hose drum (▮▮▮▶ p. 3 - 38). By doing this you prevent the hydraulic hoses tearing when the main boom is telescoped.



The information in this section also applies to telescoping with a rigged boom extension.

The telescoping of the main boom with rigged lattice extension is monitored by the SLI. Telescoping will only be enabled if the main boom is derricked to a certain angle and a maximum permissible load is not exceeded. The required angle (between 75° and 83°) depends on:

- the length of the lattice extension
- the angle of of the lattice extension
- the extended length of the main boom
- the rigged counterweight
- the rigged outrigger span

You will find the required main boom angle and the maximum permissible load (weight of the hook block) in the *Lifting capacity tables*, in Chapter *Rigging tables – Swing-away lattice extension*.

If the main boom angle is too small for telescoping with the rigged lattice extension, the SLI shows the corresponding error message.

The telescoping mechanism is operated in the same way as the main boom; ▮▮▮▶ *Operating instructions GMK 5220 – Telescoping mechanism*.

3.7.4

Information about the SLI shutdown



The information in this section also applies to operation with the boom extension.

Operation with the lattice extension is monitored by the SLI.

SLI shutdowns can occur during operation with the lattice extension for the same reasons as shutdowns occurring during operation with the main boom;  *Operating instructions GMK 5220, Part 2 – Crane operation.*

When operating the hydraulically derricked lattice extension, there are two additional points to be considered:

- When using the hydraulically derricked lattice extension, different lifting capacities are released for the angles 0°, 0 - 20° and 20 - 40°. Lowering the lattice extension can lead to the SLI shutting down, when the currently raised load in the recently set angle range is not permitted.
- When the SLI has shut down, the *Lower lattice extension* movement and all other movements which increase the load moment are blocked.

52203182

3.7.5

Procedure if the permissible wind speed is exceeded

Strong winds lead to the truck crane being overloaded. For this reason, closely observe the instructions contained in the the Section *Effect of wind on crane operation*;  *Operating instructions GMK 5220, Part 2 – Crane operation*.

If, according to the <i>Lifting capacity table</i>, the maximum permitted wind speed is exceeded during operation with the heavy load lattice extension, proceed in the following manner:	
With wind speeds of up to 20 m/s	With wind speeds of over 20 m/s
<ul style="list-style-type: none">• Set down the load.• Slew the superstructure so that the main boom creates as little wind resistance as possible.	<ul style="list-style-type: none">• Set down the load.• Fully retract the main boom.• Set down the lattice extension.

52203182

3.7.6 Information about the main boom operation when the lattice extension is folded/rigged

Folded

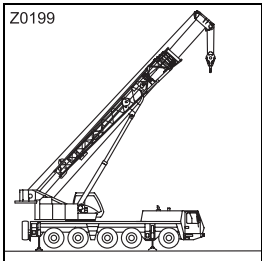

This section applies when the lattice extension is folded at the side.

If a lattice extension is folded at the side during operation with the main boom, the loads given in the *Lifting capacity tables* decrease. The relevant formulas and examples for calculating these values during operations planning can be found in the *Lifting capacity tables* in the Section *Remarks about working with the swing-away lattice extension*.

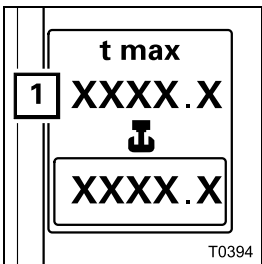

The decreased values are shown directly on the *SLI* display in the *Maximum load* display (1).

Rigged



This section applies when the lattice extension is rigged and locked to the main boom head.

Risk of overturning with impermissible rigging mode

The main boom operation with a rigged lattice extension is only permissible in rigging modes that are also permissible for the rigged lattice extension (outrigger span, counterweight, slewing range).

When you set up rigging modes that are only valid for main boom operation without a rigged lattice extension (e.g. *Free on wheels* working position), then the truck crane could overturn during operation.

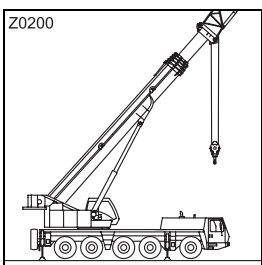

For operation with the main boom with a rigged lattice extension, you must enter the current rigging mode for the main boom without a lattice extension on the *SLI*.

The values given in the corresponding *Lifting capacity tables* for the lifting capacities and for the permissible wind speeds decrease in this case.

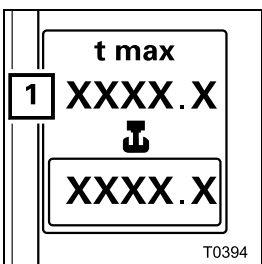

Reduction of the lifting capacity

The *Maximum load* display (1) does **not** show the reduced values.

The *SLI* also takes into account the load moment affected by the currently rigged extension and will correspondingly switch off earlier.

In the *Lifting capacity tables* you will find tables with values for the reduction of the lifting capacities in the *Section Remarks about working with the swing-away lattice extension*. The given values for reduction are only maximum values for certain rigging modes (angle and length of main boom and lattice extension).

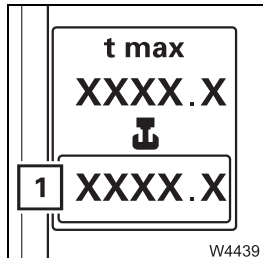

However, the SLI takes into account the value for the currently rigged lattice extension, adds the weight of the raised load and displays the sum on the *Current load* display (1).

The displayed value could deviate from the value that was previously calculated during the operations planning.

This does not mean that the SLI is defective. Do not override the SLI, even when the displayed value is higher than the calculated value.



Danger of accidents if SLI is overridden!

Never override the SLI.

If the SLI is overridden, the crane operations will not be monitored and the truck crane will overturn if you leave the permissible working range.

Reduced values for the maximum wind speed

There are also the maximum permissible wind speeds for this special rigging mode in the tables with values for the reduction of the lifting capacities.

- Stop operating the crane when the specified wind speeds have been reached.



Risk of accidents due to high wind speeds

Pay attention to the wind speeds that apply to this specific case in the *Lifting capacity tables*.

When the given wind speeds have been reached, you must stop operating the crane; ►► *Procedure if the permissible wind speed is exceeded*, p. 3 - 101.

Blank page

52203182

3.8

Turning loads with the lattice extension

Two-hook operation is required for turning loads.

The only type of two-hook operation technically possible and protected by the SLI is described in this chapter using the turning of loads as an example.



Risk of accidents due to overloading

Lifting a load with two hooks is permissible only if the following instructions and illustrations are observed.

If these instructions are disregarded, accidents can occur due to individual parts of the truck crane being overloaded. The SLI then no longer provides protection.

Two-hook operation with the boom extension is not permitted!



Risk of accidents due to overloading

The load must always be lifted completely with the weakest part first (lattice extension).



For information on the position and function of the operating elements required;  *Operating instructions GMK 5220 – Part 2, Crane operation – Operating elements*.

3.8.1

Prerequisites

The following description requires that:

- the main hoist rope is reeved on the main boom
- the auxiliary hoist rope is reeved on the lattice extension
- the lifting limit switches for both hoists are connected



Risk of accidents due to overloading

The reeving on the main boom must be equal to or greater than that on the lattice extension.

The main hoist rope and the main hoist will become overloaded if this condition is not met.

3.8.2

Setting the SLI

You must enter the following settings on the SLI for two-hook operation:

- Enter the current reeving for the main and auxiliary hoist.
The values are stored and called up directly when switching hoists.
- Switch on operation with both hoists in such a way that the digit for the auxiliary hoist lights up on the *Hoists* indicator lamp.

Entering a reeving

You can enter the reeving for both hoists at any time, independent of which hoist is switched on.

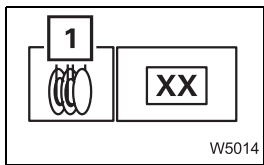

When the *Enter reeving* symbol (1) is shown without digits on the *Reeving* display, you must switch on input mode first:

- Press the button next to the symbol (1) once.

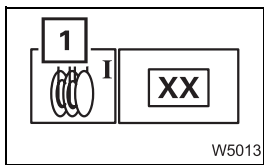

The symbol (1) will be highlighted in green and input mode is enabled. A digit also now appears beside the symbol, e.g. I.

This digit shows which hoist the displayed reeving applies to:

Digit I: Main hoist

Digit II: Auxiliary hoist

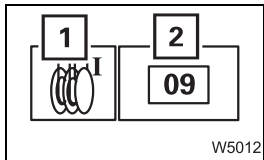

- In the *Reeving* display (2), enter the current number of runs of the reeved hoist rope for the hoist shown (↑ ↓), e.g. **09**, for the main hoist.

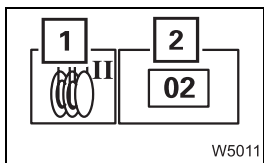

- Press the button next to the symbol *Enter reeving* (1) repeatedly until the digit for the other hoist is shown (e.g. II for the auxiliary hoist).
- In the *Reeving* display (2), enter the current number of runs of the reeved hoist rope for this hoist (↑ ↓), e.g. **02** for the auxiliary hoist.

Now the reevings have been entered for both hoists.

Setting the SLI to the auxiliary hoist

The SLI always takes into account the reeving entered for the hoist which is displayed at the *Hoists* indicator lamps. For turning loads, the SLI must take the auxiliary hoist and its reeving into account and both hoists must be switched on. To access this SLI setting, proceed as follows:

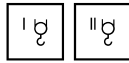

- Switch off both hoists.
To do so, press the bottom part of both rocker buttons *Main hoist on/off* and *Auxiliary hoist on/off* once.
The indicator lamps in the rocker buttons are dimly lit.



- Switch on the auxiliary hoist.
To do so, press the bottom part of the *Auxiliary hoist on/off* rocker button once. The indicator lamp in the rocker button lights up brightly.

At the *Hoists* indicator lamps, lamp **II** for the auxiliary hoist now lights up.

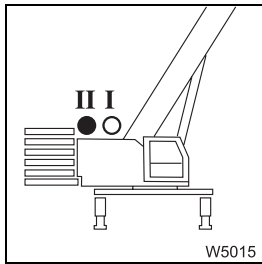

- Now switch on the main hoist.
To do so, press the bottom part of the *Main hoist on/off* rocker button once. The indicator lamp in the rocker button lights up brightly.

At the *Hoists* indicator lamps, lamp **I** for the main hoist now flashes additionally.

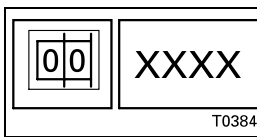
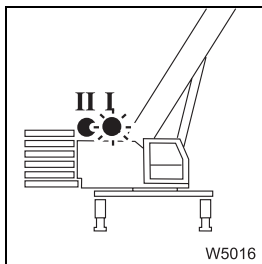

- On the SLI, select the current rigging mode with the rigged lattice extension or enter the appropriate SLI code according to the *lifting capacity table*.

The SLI is now set for two-hook operation. It now takes into account:

- The reeving for the auxiliary hoist and
- The lifting capacity tables for the heavy load lattice extension.



In two-hook operation, the load measurement is taken using the pressure in the derricking cylinder. The loads detailed in the *Lifting capacity table* then decrease by the weight of both reeved hook blocks.

3.8.3

Turning a load

Carry out the load turning only as it is described in this section.

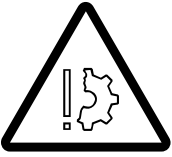

Risk of accidents due to overloading

Keep the acceleration forces as low as possible during two-hook operation.

For this reason, move the load at the lowest possible speed!



If the load is on two hooks, there will be slight differences in the *Current load* display. However, the differences concerning SLI shutdown are on the safe side.



During the entire lifting operation, the rigging mode with the lattice extension must be entered on the SLI and displayed.

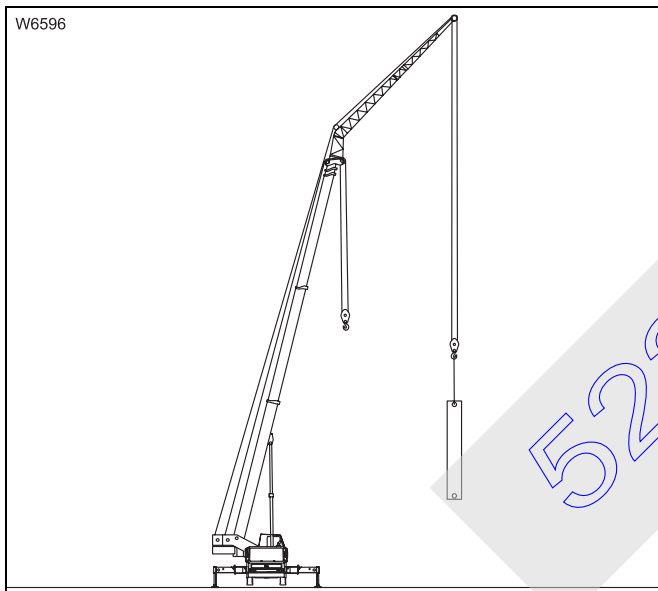

- First, only sling the load to the hook block of the lattice extension (rope of the auxiliary hoist).
- Lift the load fully with the lattice extension.

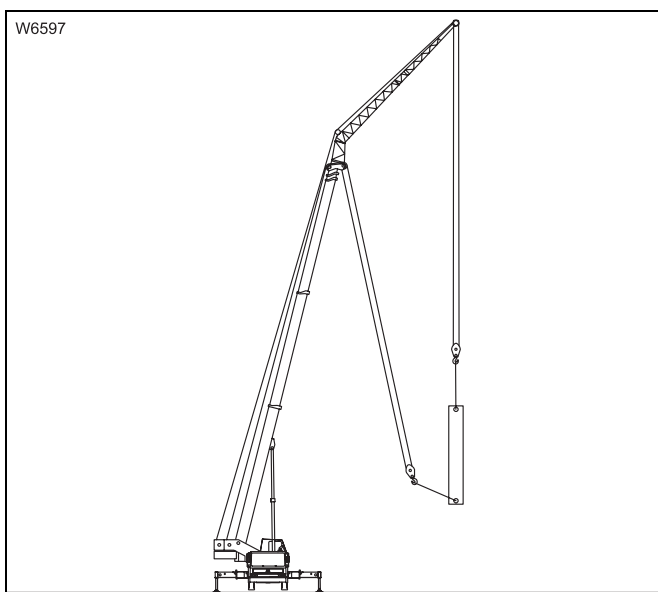

- Only now should you attach the load to the hook block of the main boom as well (main hoist rope).

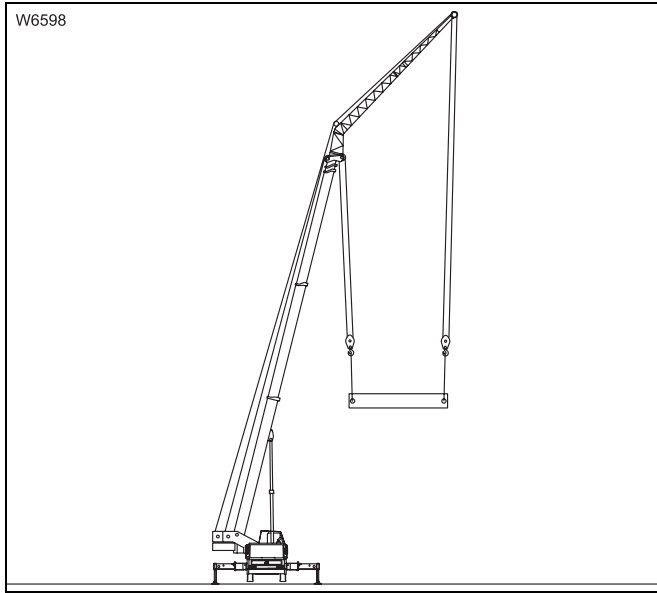

- Now lift the load with the hook block on the main boom until both slinging points are at the same height.

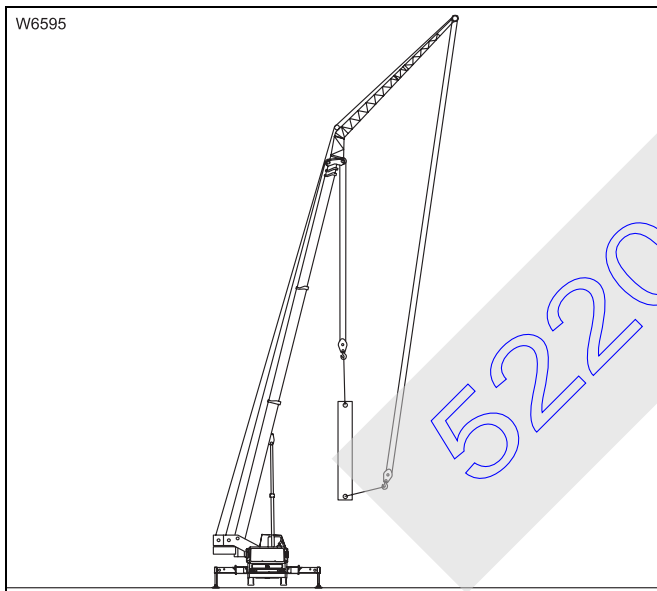

- Slacken the hoist rope on the lattice extension until the load is only hanging from the hook block on the main boom.

Turning the load has now been completed.

Blank page

52203182

3.9

Driving with rigged truck crane and rigged lattice extension

This section describes how you can move the truck crane with an installed counterweight and rigged lattice extension (e.g. when the lattice extension cannot be rigged on the site due to lack of space).



Risk of accidents when driving with a lifted load

When using a rigged lattice extension, you must not move the truck crane with a load on the hook.

Put the load down before you move the truck crane.



Risk of accidents due to swinging hook block

Secure the hook block against swinging when driving the rigged truck crane.



Risk of overturning when rotating the superstructure

When driving the rigged truck crane, the slewing gear brake must be closed.



Danger of accidents by being unable to overview the entire truck crane!

While driving the equipped truck crane, always stay in visual or radio contact with a banksman who can observe the parts which you cannot see.

This prevent accidents resulting from collisions with persons, other construction equipment, ledges of buildings, cables or other objects.



Risk of accidents when driving from the crane cab

Before moving the truck crane from the crane cab, observe all instructions the *Operating instructions GMK 5220* and set the rigging code described therein for free-standing works;  *Operating instructions GMK 5220 – Driving the truck crane from the crane cab.*

3.9.1

Driving route

The route must be along a flat, even surface. The level adjustment system cannot compensate for uneven surfaces. If the surface pressure of the tyres exceeds the permissible load on the ground, the bearing surface pressure must be increased using packing made of durable material (e.g. wooden planks).



Risk of damage to tyres

Check the pressure in the tyres before moving the rigged truck crane.

The truck crane may be moved only if tyre pressures are at the prescribed levels  *Operating instructions GMK 5220 – Part 1, Driving – Technical data.*

Do **not** reduce the tyre pressure in order to increase the bearing surface!

52203182

3.9.2

Boom positions and axle loads

The truck crane may only be moved under certain circumstances. The main boom and the lattice extension must be moved to specified positions, depending on the counterweight installed.



Risk of damage to the axle lines

Always move the main boom and the lattice extension to the specified position before you move the rigged truck crane. Positions which deviate from the specified position cause impermissible loads on the axle lines.

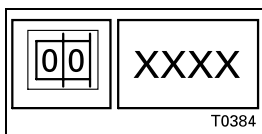

- Enter SLI code according to the *lifting capacity table* for the actual rigging mode of the truck crane with the rigged lattice extension.
- Move the main boom and the lattice extension into the prescribed positions. The prescribed boom position can be found in the following tables.



Danger of accidents if SLI is overridden!

Always set the SLI code corresponding to the current rigging mode when you derrick the main boom or lattice extension into the prescribed position. Do not override the SLI; the prescribed positions in the following tables are all within the areas which are permitted according to the *Lifting capacity tables*.

The truck crane operates without overload protection when the SLI is overridden!

Notes on the tables

The axle loads specified in the following tables refer to a driving mode with the basic unit.

The following footnotes apply in all tables:

- | | |
|-------------------------------|---|
| 1) Boom position to the rear: | 0° position, boom over rear edge of truck crane |
| Boom position to the front: | 180° position, boom over driver's cab |
| 2) Axle load to the front: | on the 1st to 3rd axle lines, as applicable |
| Axle load to the rear: | on the 4th and 5th axle lines, as applicable |



12 m (39 ft) swing-away lattice extension

All the axle loads in the following table apply for a **32 t hook block** (weight 600 kg (1320 lbs)) reeved on the lattice extension.



The maximum axle load specified in the table is reached at a main boom angle of either x° or y° . When the maximum axle load is reached e.g. to the front, the axle load to the rear is under the specified maximum axle load. At main boom angles between x° and y° , the axle loads are under the specified maximum axle loads.

Counterweight in t (lbs)	Telescoping Telescopic section I-II-III-IV-V-VI	Main boom angle x° to y°	Lattice inclination in $^\circ$	Main boom position ¹⁾	Maximum axle load ²⁾ in t (x 1000 lbs)	
					front	rear
21.0 (46 200)	0 - 0 - 0 - 0 - 0 - 0	60 - 80	5	rear	17,0 (37.5)	22,0 (48.5)
26.0 (57 300)	0 - 0 - 0 - 0 - 0 - 0	60 - 80	5	rear	19,0 (41.9)	22,0 (48.5)
31.0 (68 300)	0 - 0 - 0 - 0 - 0 - 0	60 - 80	5	rear	20,5 (45.2)	22,0 (48.5)
36.0 (79 300)	0 - 0 - 0 - 0 - 0 - 0	60 - 80	5	rear	22,0 (48.5)	22,0 (48.5)
41.0 (90 300)	0 - 0 - 0 - 0 - 0 - 0	60 - 80	5	rear	23,5 (51.8)	22,0 (48.5)
46.0 (101 400)	0 - 0 - 0 - 0 - 0 - 0	60 - 80	5	rear	25,5 (56.2)	22,0 (48.5)
51.0 (112 400)	0 - 0 - 0 - 0 - 0 - 0	45 - 60	5	rear	23,0 (50.7)	26,0 (57.3)
71.0 (165 500)	0 - 0 - 0 - 0 - 0 - 0	35 - 50	5	rear	28,0 (61.7)	28,0 (61.7)
77.0 (169 700)	0 - 0 - 0 - 0 - 0 - 0	35 - 37	5	rear	28,0 (61.7)	28,0 (61.7)

1), 2) Notes on the tables, p. 3 - 113

21 m (69 ft) swing-away lattice extension

All the axle loads in the following table apply for **hook tackle** (weight 300 kg (660 lbs)) reeved on the lattice extension.



The maximum axle load specified in the table is reached at a main boom angle of either x° or y° . When the maximum axle load is reached e.g. to the front, the axle load to the rear is under the specified maximum axle load. At main boom angles between x° and y° , the axle loads are under the specified maximum axle loads.

Counter-weight in t (lbs)	Telescoping section I-II-III-IV-V-VI	Main boom angle x° to y°	Lattice inclination in $^\circ$	Main boom position ¹⁾	Maximum axle load ²⁾ in t (x 1000 lbs)	
					front	rear
21.0 (46 200)	0 - 0 - 0 - 0 - 0 - 0	50 - 80	5	rear	17,5 (38.6)	25,0 (55.1)
26.0 (57 300)	0 - 0 - 0 - 0 - 0 - 0	50 - 80	5	rear	19,0 (41.9)	25,0 (55.1)
31.0 (68 300)	0 - 0 - 0 - 0 - 0 - 0	45 - 80	5	rear	20,5 (45.2)	26,5 (58.4)
36.0 (79 300)	0 - 0 - 0 - 0 - 0 - 0	45 - 80	5	rear	22,5 (49.6)	26,5 (58.4)
41.0 (90 300)	0 - 0 - 0 - 0 - 0 - 0	40 - 80	5	rear	24,0 (52.9)	27,5 (60.6)
46.0 (101 400)	0 - 0 - 0 - 0 - 0 - 0	40 - 75	5	rear	24,5 (54.0)	27,5 (60.6)
51.0 (112 400)	0 - 0 - 0 - 0 - 0 - 0	40 - 75	5	rear	26,0 (57.3)	28,0 (61.7)
71.0 (165 500)	0 - 0 - 0 - 0 - 0 - 0	40 - 50	5	rear	28,0 (61.7)	28,0 (61.7)
77.0 (169 700)	Driving with rigged truck crane not permitted . Unrig the counterweight combination to 71.0 t (165 500 lbs).					

1), 2) Notes on the tables, p. 3 - 113

3.9.3

Driving the rigged crane

Closing the slewing gear brake



- Switch the slewing gear off; to do this, press the *Slewing gear on/off* rocker button up once.



The slewing gear brake will be engaged at the same time and the *Slewing gear brake* indicator lamp will light up on the *Crane control* insert.



The slewing gear brake is automatically applied if the crane engine is at a standstill.



During the following work, you must temporarily switch on and switch off the suspension, which is possible only in the driver's cab. It is therefore recommended to carry out the following work from the carrier.

Retracting the outriggers

- Retract the outrigger cylinders until the wheels are just above the ground.



Risk of overturning when outrigger cylinders are retracted unevenly

Retract all the outrigger cylinders as uniformly as possible.

This prevents the truck crane from overturning while retracting the outrigger cylinders.

Switching over suspension

Operation is carried out on the *Driver's cab display*, in the *Level adjustment system* submenu;  *Operating instructions GMK 5220 – Part 1 Driving – Suspension*.

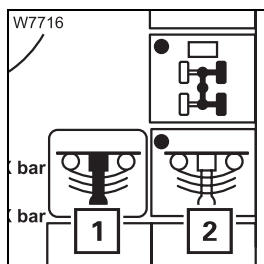

- Turn on the suspension. To do so, press the button next to the *Suspension on/off* symbol once (2). The point turns green.

When the suspension is switched on, the *Suspension* display (1) shows the **green** *Suspension on* symbol.

- All wheels are now lowered to the ground.
- Retract the outrigger cylinders so far that the truck crane is located on a level where there is still enough room for suspension movement in both directions.

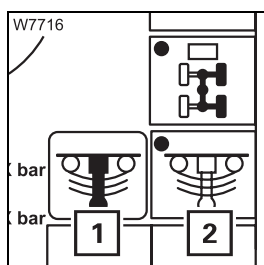

- Turn off the suspension. To do so, press the button next to the *Suspension on/off* symbol once (2).

The *Suspension* display (1) shows the **red** symbol for *Suspension off* and suspension is locked.

- Continue to retract the outrigger cylinders.



Risk of overturning when switching on the suspension

As long as the rigged truck crane is on wheels, you must not turn on the suspension for any reason. The suspension is no longer under pressure and when the suspension is switched on, the suspension struts would be pressed together abruptly, damaging them and possibly causing the truck crane to tip over.



Danger of overturning!

To reduce the risk of the crane overturning do not raise the outrigger pads more than 5 to 10 cm off the ground. Leave the outrigger beams extended.



Switching on separate steering

Before driving with the rigged crane you must switch on separate steering:

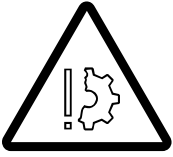

Risk of damaging the steering linkage

Before driving the rigged crane always switch on separate steering. Steer the truck crane only when the vehicle is moving.

If separate steering is switched off or if you steer with the vehicle stationary the steering linkage may become damaged.

To continue operating the separate steering; *Operating instructions GMK 5220 – Part 1 Driving – Switching on separate steering.*

Driving



Risk of damage to tyres!

Check the pressure in the tyres before moving the rigged truck crane.

The truck crane may be moved only if tyre pressures are at the prescribed levels; *Operating instructions GMK 5220 – Part 1 Driving – Technical data.*

Do **not** reduce the tyre pressure in order to increase the bearing surface.



Check the wind speed before moving the rigged truck crane. The same maximum permitted wind speeds apply for moving the crane as for working with the crane; *Operating instructions GMK 5220 – Effect of wind on crane operation.*

Before driving

- Shift into the lowest starting gear.

This prevents upshifting of the gears and the speed is kept to a minimum;

Operating instructions GMK 5220 – Part 1 Driving – Operating the gears.

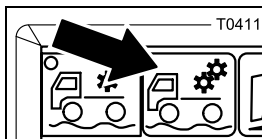
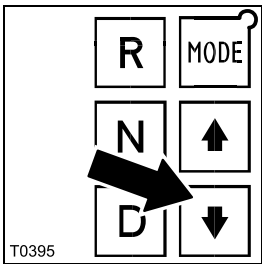

- Switch into off-road gear; *Operating instructions GMK 5220 – Part 1 Driving – transfer case.*

Please observe the following points when driving:

- Drive as slowly as possible.
- The turning radius should be as large as possible when driving around corners.
- Steer the truck crane only when it is rolling and avoid sudden steering movements.

When the surface is uneven, the truck crane must be raised with the outrigger cylinders, horizontally aligned and then re-lowered, as described in the following section.

Levelling the free-standing truck crane

If the rigged truck crane is on wheels and the suspension is switched off, then you must not under any circumstances switch on the suspension.



Risk of overturning when switching on the suspension

As long as the rigged truck crane is on wheels, you must not turn on the suspension for any reason. The suspension is no longer under pressure and when the suspension is switched on, the suspension struts would be pressed together abruptly, damaging them and possibly causing the truck crane to tip over.

You must therefore align the truck crane as follows.

- Extend the outrigger cylinders until all wheels are just above the ground.
- Align the truck crane horizontally with the outrigger cylinders.

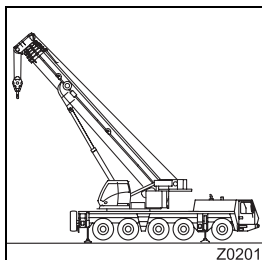

Risk of crushing when switching on the suspension

When the suspension is switched on, the wheels drop down suddenly. Ensure that nobody is in close proximity to the wheels when you switch on the suspension.



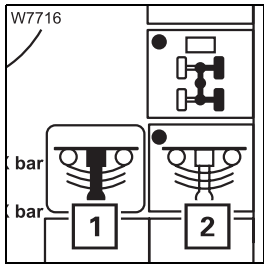

- Turn on the suspension. To do so, press the button next to the *Suspension on/off* symbol once (2).

The *Suspension* display (1) shows the **green** symbol for *Suspension on*.

- All wheels are now lowered to the ground.
- Retract the outrigger cylinders so far that the truck crane is located on a level where there is still enough room for suspension movement in both directions.

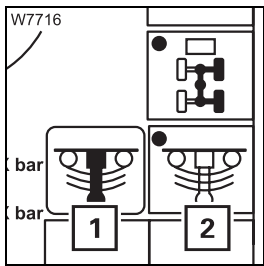

- Turn off the suspension. To do so, press the button next to the *Suspension on/off* symbol once (2).

The *Suspension* display (1) shows the **red** symbol for *Suspension off* and suspension is locked.

- Retract the outrigger cylinders until the outrigger pads are approx. 10 cm (4 in) above the ground.



Risk of overturning

To reduce the risk of the truck crane overturning, do not raise the outrigger pads more than 5 to 10 cm (2 to 4 in) off the ground. Leave the outrigger beams extended.

Supporting the truck crane

Before beginning crane work, support the truck crane with the outrigger span required for the planned use of the truck crane according to the *Lifting capacity table*; *Operating instructions GMK 5220 – Part 2 Crane operation – Outriggers*.



Risk of overturning when wheels touch the ground

Raise the truck crane on the outriggers until none of the wheels are touching the ground.

In this way you prevent changes to the stability of the truck crane which would increase the risk of it overturning.

3.10 Finding and eliminating malfunctions

Malfunction	Cause	Remedy
Lifting limit switch not functioning	Lifting limit switch not connected	Connect the lifting limit switch; ■■■▶ p. 3 - 82.
	The connection for the lifting limit switch on the main boom head is not overridden. There is a second lifting limit switch connected to the main boom and it is not locked.	Override the lifting limit switch on the main boom head; ■■■▶ p. 3 - 82.
	For 12 m (39 ft): Electrical connection between main boom head and section 1 is not established. The bridging plug is not inserted in the socket to the front of section 1.	Establish the electrical connection; ■■■▶ p. 3 - 74. Change over the bridging plug; ■■■▶ p. 3 - 75.
	For 21 m (69 ft): Electrical connection between main boom head and section 1 is not established. Electrical connection between section 1 and section 2 is not established.	Establish the electrical connection; ■■■▶ p. 3 - 74. Establish the electrical connection; ■■■▶ p. 3 - 76.
The main boom cannot be telescoped with the rigged lattice extension	The main boom is at an impermissible angle.	Derrick the main boom to the required angle; ■■■▶ p. 3 - 99.
The lattice extension cannot be derricked	Derricking gear of the lattice extension is switched off	Switch on the derricking gear of the lattice extension; ■■■▶ p. 3 - 1.
	The electrical connection has been broken.	Establish the electrical connection; ■■■▶ p. 3 - 74.
	The hydraulic connection has been disconnected.	Establish a hydraulic connection; ■■■▶ p. 3 - 77.
	The specified SLI code does not apply to operation with the lattice extension.	Enter the SLI code for operation with the lattice extension; ■■■▶ p. 3 - 96.
	Current load greater than derricking load – <i>lower lattice extension</i> movement is disabled. SLI error code 5 02 6 is displayed.	<ol style="list-style-type: none"> 1. Raising the lattice extension. 2. Press button <input type="button" value="CE"/> once. 3. If necessary, increase the working radius using the <i>lower main boom</i> movement.

Blank page

52203182

3.11 Maintenance work

3.11.1 Modules in need of protection during cleaning work

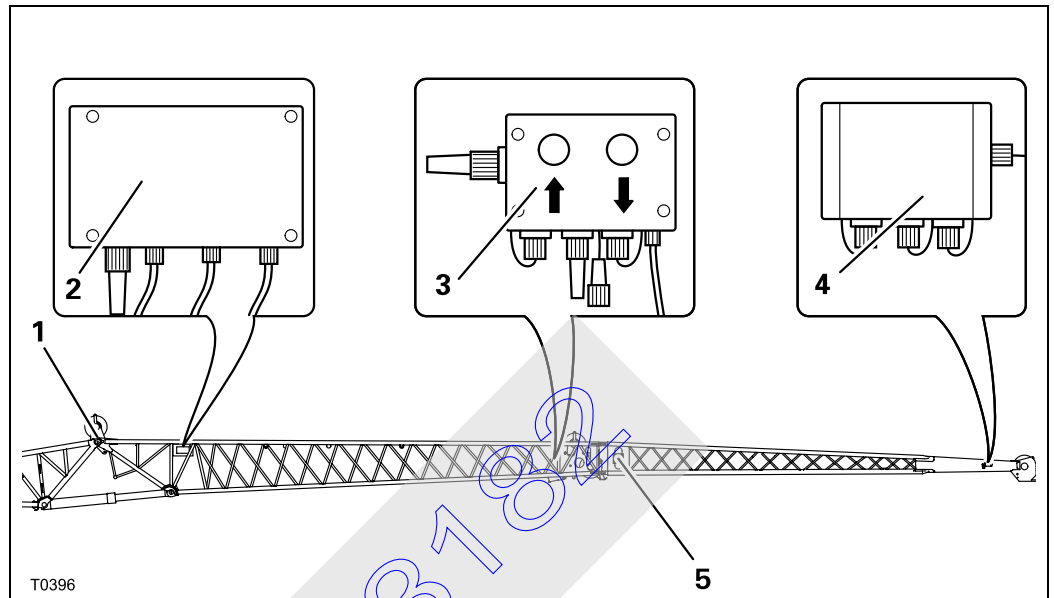

- Provide protection for the following electrical parts during cleaning work:

- 1 the differential angle indicator on section 1
- 2 the control box at the rear of section 1
- 3 the control box at the front of section 1
- 4 the control box at the front of section 2
- 5 the electrical pin-and-socket connector on section 2



Also observe all instructions contained in the *Maintenance manual* for the GMK 5220 under the chapter *Cleaning work*.

3.11.2

Maintenance work M1, monthly



For lubricating the pins and support rollers, use the same grease as stated in the *Maintenance manual* as for connecting pins and socket pins; *Maintenance manual GMK 5220 Maintenance overview – Maintenance Plan M1*.

Pins

Lubricate all pins on the lattice extension, in other words:

- the pins for the connections with folded-up lattice extension;
- the pins for the connections on the left and right of the main boom head; p. 3 - 60,
- the pins for the connections on the lattice extension; p. 3 - 69,
- the pins on the deflection sheave; p. 3 - 77,
- the spring latch for the locking device on the hose drum; p. 3 - 38.



The maintenance interval applies to average operation. Also lubricate the pins after high-pressure cleaning and generally at an interval that will prevent them getting dry.

52203192

3.11.3

Maintenance work M12, every twelve months

Lubricate joints on section 1

The joints in section 1 are lubricated via lubricating nipples.

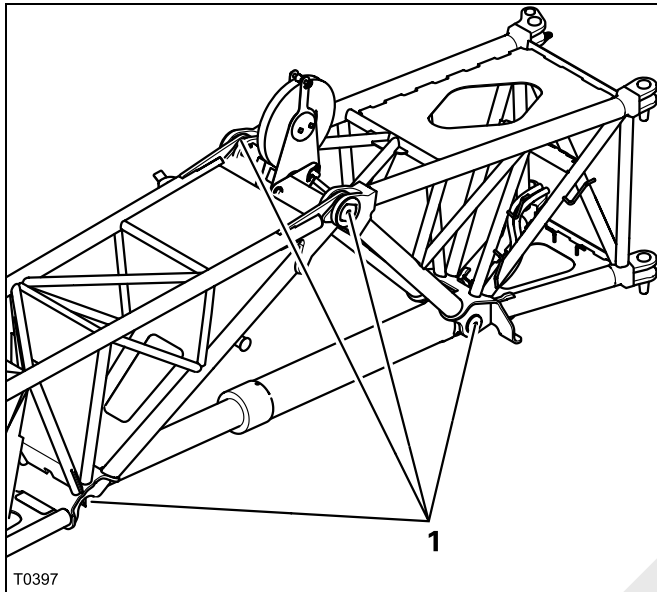

In section 1 there is one lubricating nipple (1) in the pivot point.

- Clean the lubricating nipple and lubricate it with a grease gun.
- Also lubricate the joint on the other side.

52203182

Blank page

52203182

4	Boom extension	
4.1	Identification and slinging points	4 - 1
4.1.1	Identification	4 - 1
4.1.2	Slinging points	4 - 2
4.2	Assembly of boom extensions	4 - 3
4.3	Checklists for rigging work	4 - 5
4.3.1	CHECKLIST: Rigging the 29/37 m (95/121 ft) boom extension	4 - 5
4.3.2	CHECKLIST: Unrigging the 26/32 m (85/121 ft) boom extension	4 - 9
4.4	Description of rigging work	4 - 14
4.4.1	Installing/dismantling section 3 and section 4	4 - 14
4.4.2	Installing/dismantling the lattice extension for the boom extension	4 - 16
4.4.3	Hydraulic connection at the boom extension	4 - 18
4.4.4	Electrical connection at the boom extension	4 - 22
4.4.5	Fold in/fold out the deflection sheave on section 3	4 - 26
4.4.6	Positioning/removing the hoist rope	4 - 27
4.5	Working with the boom extension	4 - 30
4.6	Driving with rigged truck crane and rigged boom extension	4 - 32
4.6.1	Driving route	4 - 33
4.6.2	Boom positions and axle loads	4 - 34
4.6.3	Driving the rigged crane	4 - 37
4.7	Maintenance work	4 - 37
4.7.1	Maintenance work M1, monthly	4 - 37

52203182

4

Boom extension

4.1

Identification and slinging points

4.1.1

Identification

The boom extension consists of the 21 m (69 ft) swing-away lattice extension and two boom extension sections. The boom extension is designed for the truck crane it was delivered with. The parts which belong to the truck crane have the same serial number as the truck crane.

The following sections are identified by the serial number:

- Section 1 and section 2 of the 21 m (69 ft) swing-away lattice extension;
 ▶ p. 3 - 7,
- Section 3 (8 m (26 ft)) with deflection sheave
- Section 4 (8 m (26 ft)) without deflection sheave



Risk of accidents during operation with non-modified lattice extension

Operate the truck crane only with those sections of the boom extension which have the same serial number as the crane.

The SLI is only set for this boom extension.

This prevents malfunctions and damage.



For technical reasons a truck crane may only be set with one boom extension.

If you wish to use the boom extension on several GROVE truck cranes, the parts of the boom extension must be adjusted for these cranes and labelled with all of the respective serial numbers.



Risk of accidents if not adjusted correctly

The adjustment of the boom extension may only be carried out by **CraneCARE**.



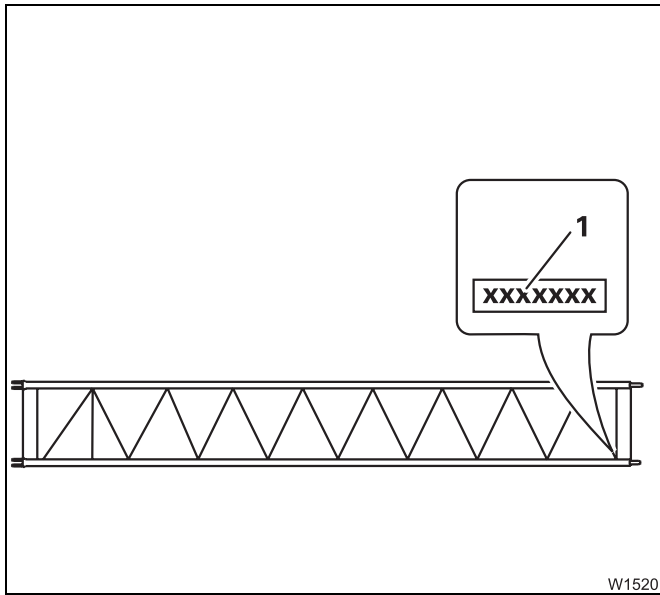

Serial numbers on section 3 and section 4

On section 3 and section 4, the serial number (1) is at the front on a plate.

4.1.2 Slinging points



Risk of accidents due to falling lattice extension sections

Only sling section 3 and section 4 at the slinging points provided. Only use sling gear with the same length to ensure that the sections reach the centre of gravity.

Use only lifting gear with sufficient lifting capacity;  *Swing-away lattice extension*, p. 2 - 1.

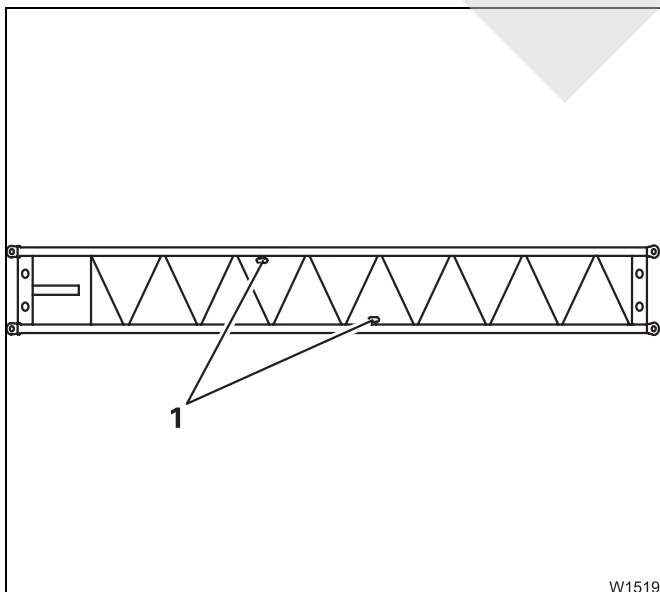

Section 3 and section 4 each have two slinging points (1).

4.2

Assembly of boom extensions



Risk of accidents from incorrect assembly

Assemble the boom extension as shown here. Section 3 must always be bolted to the deflection sheave on the main boom head. When section 4 is bolted to the main boom head, the hoist rope rubs and may be damaged.

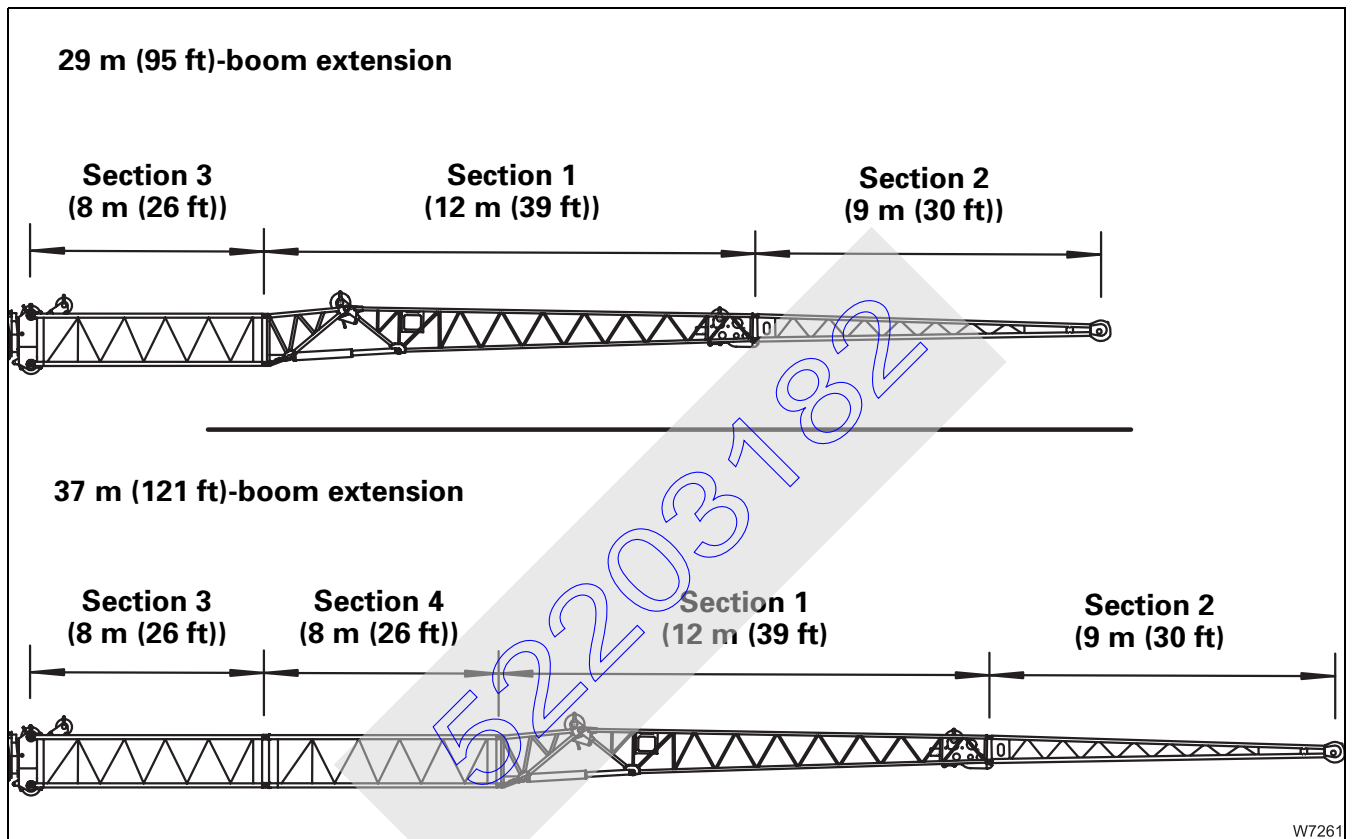

The length data for the boom extension of 29 m (95 ft) and 37 m (121 ft) corresponds to the distance between the centre of the locking pin (on the main boom head) and the front edge of the head sheave.

That is why the length data of the components in the *Transport dimensions and weights* section and their sums do not correspond to the specified lattice extension lengths; p. 2 - 1.

Blank page

52203182

4.3

Checklists for rigging work

4.3.1

CHECKLIST: Rigging the 29/37 m (95/121 ft) boom extension



This checklist is not equivalent to complete operating instructions. There are accompanying instructions which are indicated by cross-references. **Observe the warning and safety instructions given there.**

Prerequisites:

- The truck crane is on outriggers or the main boom has been placed on the boom rest.
- An auxiliary crane is available.

1. Prepare the truck crane for unrigging;

▣▣▣▣▶ *Preparing the truck crane for rigging*, p. 3 - 31.

2. If the lattice extension is folded up at the side of the main boom, remove the lattice extension; ▣▣▣▶ p. 3 - 14.

3. Check that the locking device is released and, if necessary, move the hydraulic connection of the hose drum into the position for *lattice extension* operation.

▣▣▣▣▶ *Checking the locking device on the hose drum*, p. 3 - 38.

▣▣▣▣▶ *Position for working with the lattice extension*, p. 3 - 40.

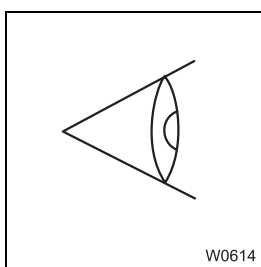
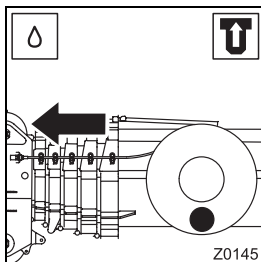

4. Check the transport condition of the lattice extension; ▣▣▣▣▶ *Transport condition with removed lattice extension*, p. 3 - 37.

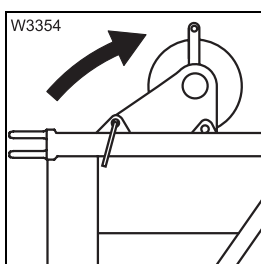

5. Fold out deflection sheaves on section 3; ▣▣▣▣▶ *Fold in/fold out the deflection sheave on section 3*, p. 4 - 26.



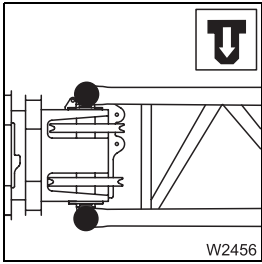

6. Sling the necessary sections onto the auxiliary crane one after the other and install in front of the main boom:
- For 29 m (95 ft) boom extension section 3,
 - For 37 m (121 ft) boom extension, first section 3 and then section 4;
- ▣▣▣▣ ▣▣▣▣ *Slings points*, p. 4 - 2.
- ▣▣▣▣ ▣▣▣▣ *Installing/dismantling section 3 and section 4*, p. 4 - 14.

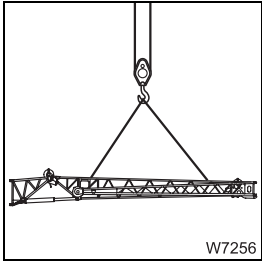

7. Sling the folded 21 m (69 ft) swing-away lattice extension onto the auxiliary crane and fasten the guide rope; ▣▣▣▣ ▣▣▣▣ *Centres of gravity for slinging*, p. 3 - 10.

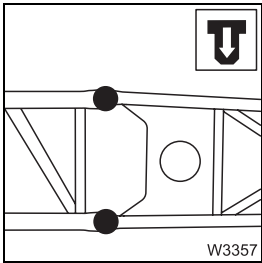

8. Folded 21 m (69 ft) swing-away lattice extension:
- For 29 m (95 ft) boom extension install in front of section 3.
 - For 37 m (121 ft) boom extension install in front of section 4;
- ▣▣▣▣ ▣▣▣▣ *Installing/dismantling the lattice extension for the boom extension*, p. 4 - 16.

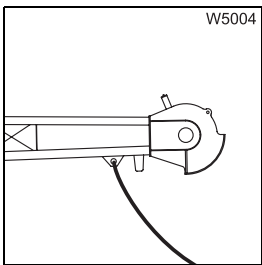

9. Fasten the guide rope to the head of section 2.

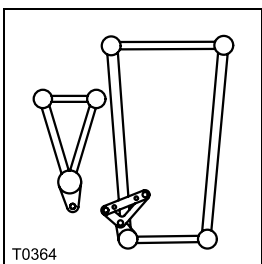

10. Move the connection in the *Middle* area into the position *Section 1/main boom*; ▣▣▣▣ ▣▣▣▣ p. 3 - 52.

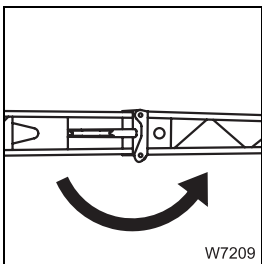

11. Swing section 2 in front of section 1; ▣▣▣▣ ▣▣▣▣ *When rigging – section 2*, p. 3 - 67.

52203182

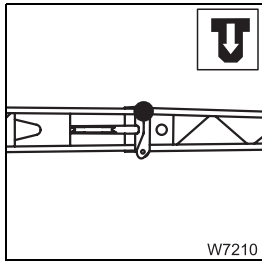

- 12.** Establish the connection on the left between section 2 and section 1;
▣▣▣▣ p. 3 - 70.

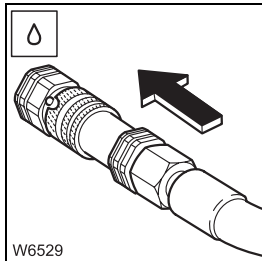

- 13.** In the case of the the hydraulically derricked lattice extension, establish the hydraulic connection;

- ▣▣▣▣ On the 29 m (95 ft) boom extension, p. 4 - 18,
▣▣▣▣ On the 37 m (121 ft) boom extension, p. 4 - 20.

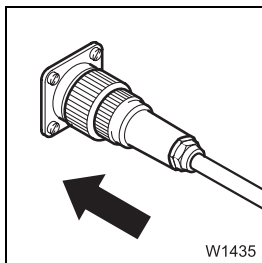

- 14.** Establish electrical connections;

- ▣▣▣▣ On the 29 m (95 ft) boom extension, p. 4 - 22,
▣▣▣▣ On the 37 m (121 ft) boom extension, p. 4 - 24.

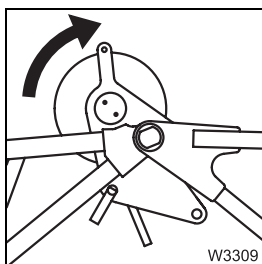

- 15.** Fold out deflection sheaves on section1;

- ▣▣▣▣ *Folding deflection sheave out/in*, p. 3 - 77.

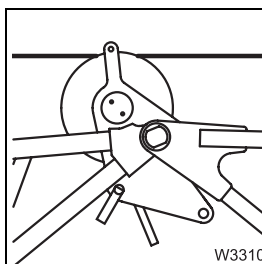

- 16.** Place the hoist rope on the boom extension; ▣▣▣▣ *Positioning/removing the hoist rope*, p. 4 - 27.

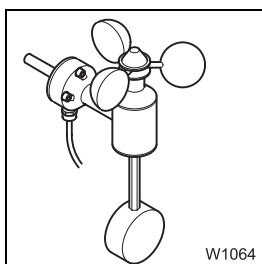

- 17.** Install the anemometer; ▣▣▣▣ *Installing/removing the anemometer*, p. 3 - 85.



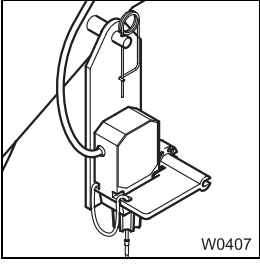

- 18.** Install the lifting limit switch; On 21 m (69 ft) swing-away lattice extension, p. 3 - 84.

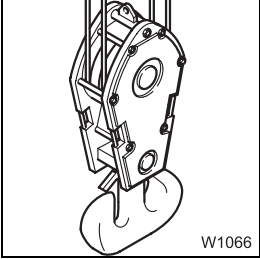

- 19.** Reeve the hoist rope; Positioning/removing the hoist rope, p. 4 - 27.

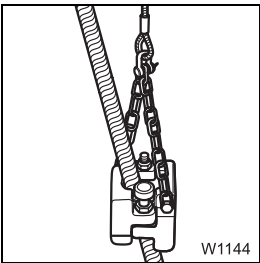

- 20.** Attach the lifting limit switch weight and place it around the hoist rope; Operating instructions GMK 5220, Part 2 Crane operation – Rigging work.

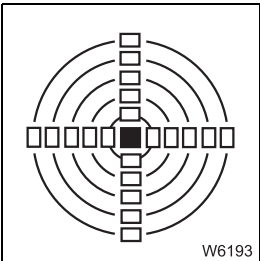

- 21.** Check the alignment of the truck crane and, if necessary, position the truck crane so that it is level.

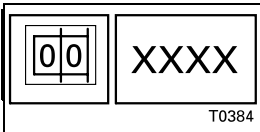

- 22.** Enter SLI code according to the *lifting capacity table* for the actual rigging status of the truck crane with the rigged lattice extension; Setting, p. 3 - 96.



Operation with the boom extension is carried out in the same way as for the lattice extension.

- Raising and setting down the main boom, p. 3 - 98,
- Telescoping with rigged lattice extension, p. 3 - 99,
- Information about the SLI shutdown, p. 3 - 100.

4.3.2

CHECKLIST: Unrigging the 26/32 m (85/121 ft) boom extension



This checklist is not equivalent to complete operating instructions. There are accompanying instructions which are indicated by cross-references. **Observe the warning and safety instructions given there.**

Prerequisites:

- The truck crane is on outriggers or the main boom has been placed on the boom rest.
 - An auxiliary crane is available.
1. Prepare the truck crane for unrigging; *Preparing the truck crane for rigging*, p. 3 - 31.

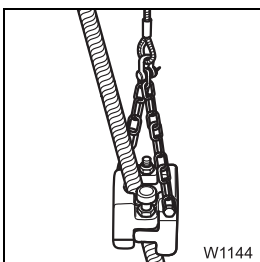
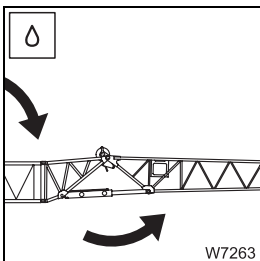
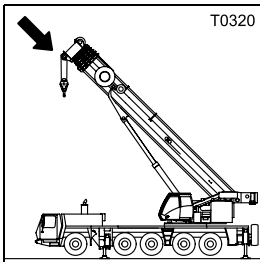
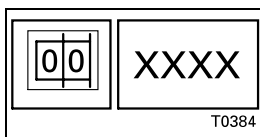

2. Enter SLI code according to the *lifting capacity table* for the actual rigging status of the truck crane with the rigged lattice extension; *Setting*, p. 3 - 96.
3. Retract the main boom completely; *Telescoping with rigged lattice extension*, p. 3 - 99.
4. This point only applies for the hydraulically derricked lattice extension.
 - Completely retract the lattice extension; *Derricking the lattice extension*, p. 3 - 91.
 - Lower the boom to the horizontal position; p. 3 - 99.
5. Remove the lifting limit switch weight and remove the lifting limit switch; *Installing/removing the lifting limit switch*, p. 3 - 82.



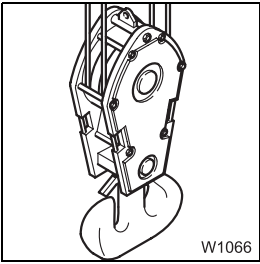

6. Reeve out hoist rope from the hook block.

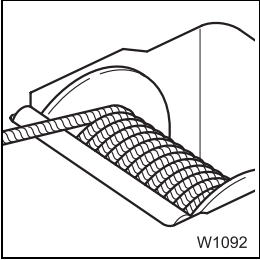

7. Reel hoist rope up to the main boom head; *Positioning/removing the hoist rope, p. 4 - 27.*

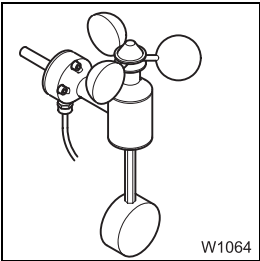

8. Remove anemometer; *Removing the anemometer, p. 3 - 88.*

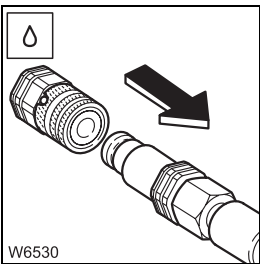

9. In the case of the the hydraulically derricked lattice extension, disconnect the hydraulic connection;

On the 29 m (95 ft) boom extension, p. 4 - 18,

On the 37 m (121 ft) boom extension, p. 4 - 20.

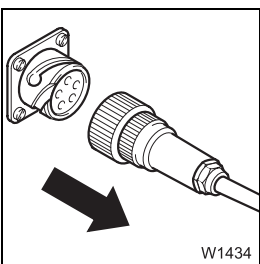

10. Disconnect the electrical connections;

On the 29 m (95 ft) boom extension, p. 4 - 22,

On the 37 m (121 ft) boom extension, p. 4 - 24.

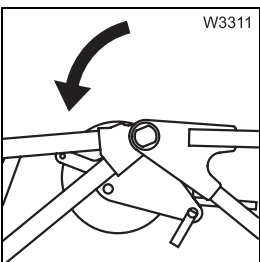

11. Fold up the deflection sheaves on section1;

Folding deflection sheave out/in, p. 3 - 77.

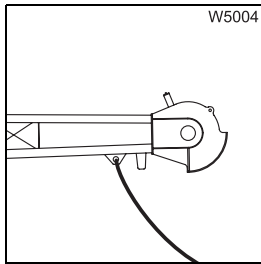

12. Fasten the guide ropes to the front of section 2.

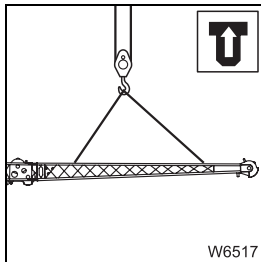

13. If section 2 is to be removed:

- Sling section 2 onto the auxiliary crane, centre of gravity;
 ▣▣▣▣▶ p. 3 - 10.
- Remove the locking pins between section 2 and section 1;
 ▣▣▣▣▶ p. 3 - 69.
- Set down section 2 on the separate vehicle.

After removing section 2, proceed as from **item 17**.

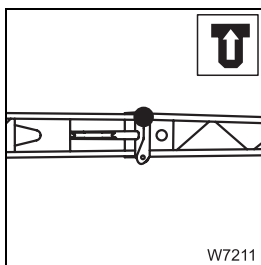

14. Disconnect the connection on the left between section 2 and section 1;
 ▣▣▣▣▶ p. 3 - 71.

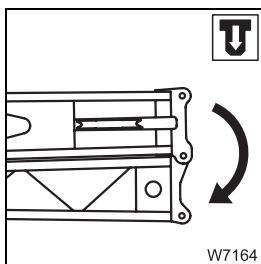

15. Swing section 2 to the side of section 1; ▣▣▣▣▶ *When unrigging – section 2,*
 p. 3 - 68,

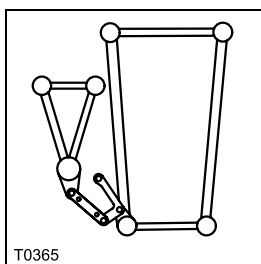

16. Move the connection in the *Middle* area into the position *Section 1/*
 section 2; ▣▣▣▣▶ *Position Section 1/section 2,* p. 3 - 51.

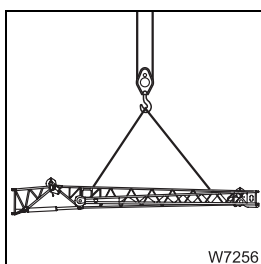

17. Sling the lattice extension on auxiliary crane and fasten the guide ropes; ▣▣▣▣▶ *Centres of gravity for slinging,* p. 3 - 10.



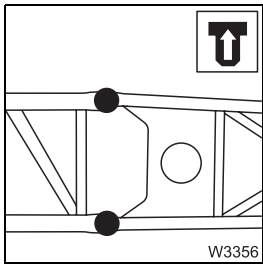

18. Remove the folded swing-away lattice extension; *Dismantling*, p. 4 - 17.

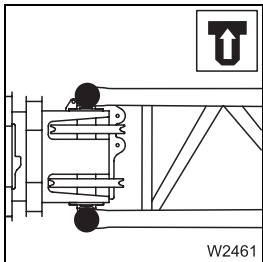

19. Sling the rigged sections onto the auxiliary crane and remove from the main boom:
- For 29 m (95 ft) boom extension section 3,
 - For 37 m (121 ft) boom extension section 4 and section 3;
- Slings points*, p. 4 - 2.
- Installing/dismantling section 3 and section 4*, p. 4 - 14

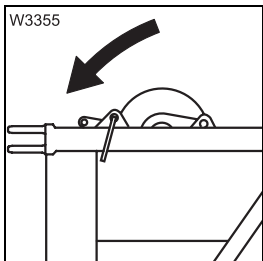

20. Fold up the deflection sheaves on section 3; *Fold in/fold out the deflection sheave on section 3*, p. 4 - 26.

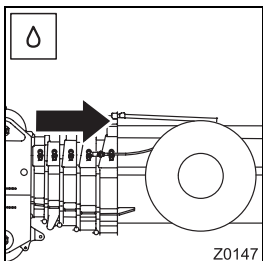

21. Check that the locking device is released and, if necessary, move the hydraulic connection of the hose drum into the position for *lattice extension operation*; *Position for working with the main boom*, p. 3 - 40.

4.4

Description of rigging work

4.4.1

Installing/dismantling section 3 and section 4

Installing

For the 29 m (95 ft) boom extension, you only need to install section 3.
For the 37 m (121 ft) boom extension, you first need to install section 3 and then section 4.



Before installing section 3, the deflection sheave must be folded out;
Fold in/fold out the deflection sheave on section 3, p. 4 - 26.

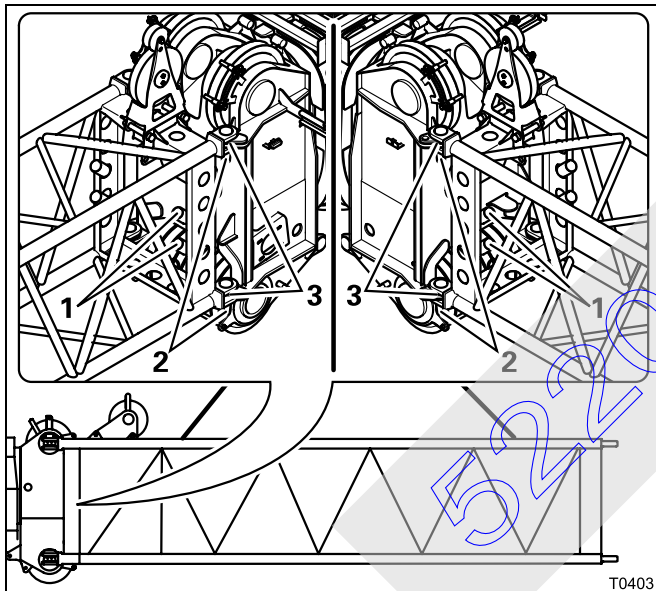

Installing section 3

- Sling section 3 to the slinging points provided; p. 4 - 2.
- Lift section 3 in front of the main boom head in such a way that the connecting points (3) align on both sides.
- Remove the retaining pins and pull the pins (2) out of the holders (1).
- Insert the pins (2) into the connecting points (3).
- Secure the pins using the retaining pins.

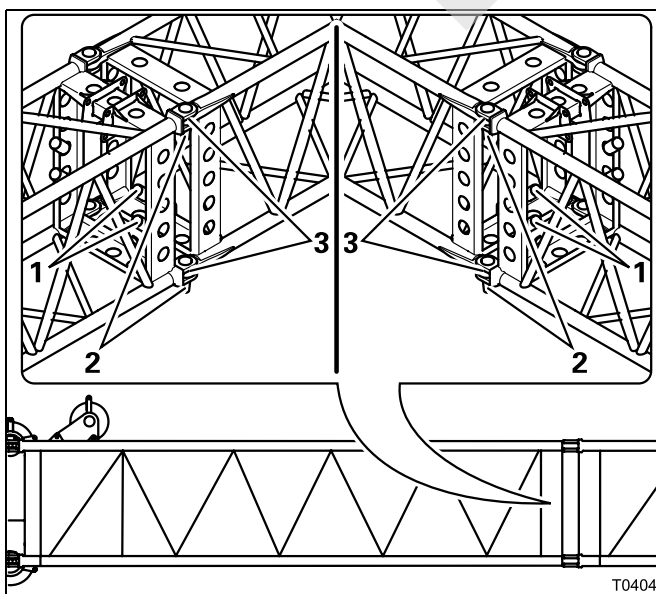

Installing section 4

- Sling section 4 to the slinging points provided; p. 4 - 2.
- Lift section 4 in front of the main boom head in such a way that the connecting points (3) align on both sides.
- Remove the retaining pins and pull the pins (2) out of the holders (1).
- Insert the pins (2) into the connecting points (3).
- Secure the pins using the retaining pins.



Dismantling

For the 37 m (121 ft) boom extension, you first need to dismantle section 4 and then section 3.

For the 29 m (95 ft) boom extension, you only need to dismantle section 3.



Risk of damage to connection cables and hydraulic hoses

Before dismantling, ensure that the electric and hydraulic connections have been cut.

This prevents damage to the connection cable and the hydraulic hoses during dismantling.

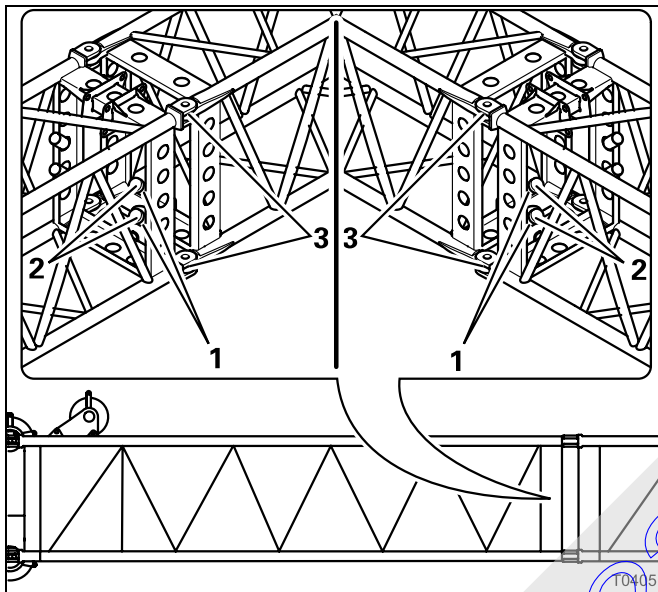

Dismantling section 4

- Sling section 4 to the slinging points provided; ►► p. 4 - 2.
- Remove the retaining pins and pull the pins (2) out of the connecting points (3).
- Insert the pins into the holders (1).
- Secure the pins using the retaining pins.
- Set down section 4.

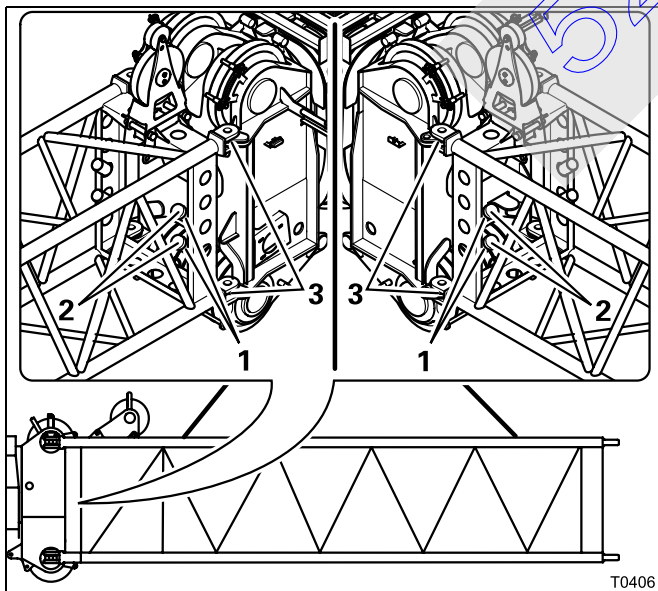

Dismantling section 3

- Sling section 3 to the slinging points provided; ►► p. 4 - 2.
- Remove the retaining pins and pull the pins (2) out of the connecting points (3).
- Insert the pins into the holders (1).
- Secure the pins using the retaining pins.
- Set down section 3.

4.4.2

Installing/dismantling the lattice extension for the boom extension

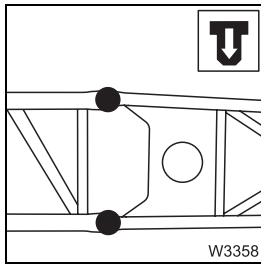

This section describes the installation and dismantling of the folded lattice extension.

You may also install the folded up lattice extension in front of section 3 or section 4 (e.g. when making a direct modification from a 21 m (69 ft) swing-away lattice extension to a boom extension).

Installing

When rigging, you must install the lattice extension.

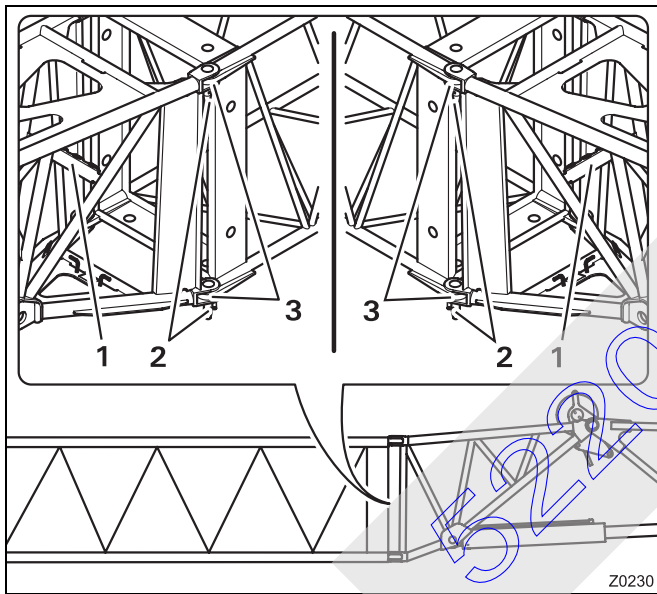

- Sling on the lattice extension in the centre of gravity; p. 3 - 10.
- Lift the lattice extension in front of the main boom head in such a way that the connecting points (3) align on both sides.
- Remove the retaining pins and pull the pins (2) out of the holder (1).
- Insert the pins (2) into the connecting points (3).
- Secure the pins using the retaining pins.



Dismantling

When unrigging, you must dismantle the lattice extension.

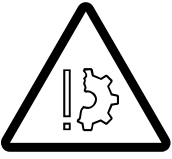

Risk of damage to connection cables and hydraulic hoses

Before dismantling, ensure that the electric and hydraulic connections have been cut.

This prevents damage to the connection cable and the hydraulic hoses during dismantling.

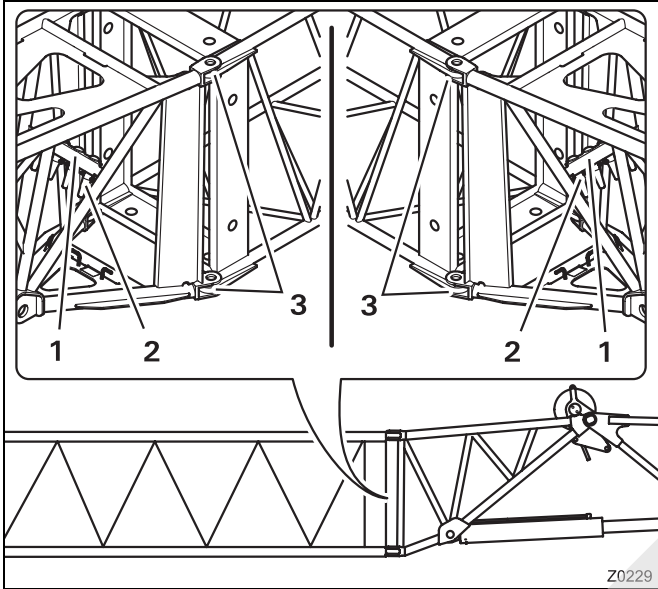

- Sling on the lattice extension in the centre of gravity; p. 3 - 10.
- Remove the retaining pins and pull the pins (2) out of the connecting points (3).
- Insert the pins into the holder (1).
- Secure the pins using the retaining pins.
- Set down the lattice extension and check the transport condition: *Transport condition with removed lattice extension*, p. 3 - 37.

4.4.3

Hydraulic connection at the boom extension

On the 29 m (95 ft) boom extension

All connections are made via quick-action couplings. The correct allocation is given using different forms and sizes.

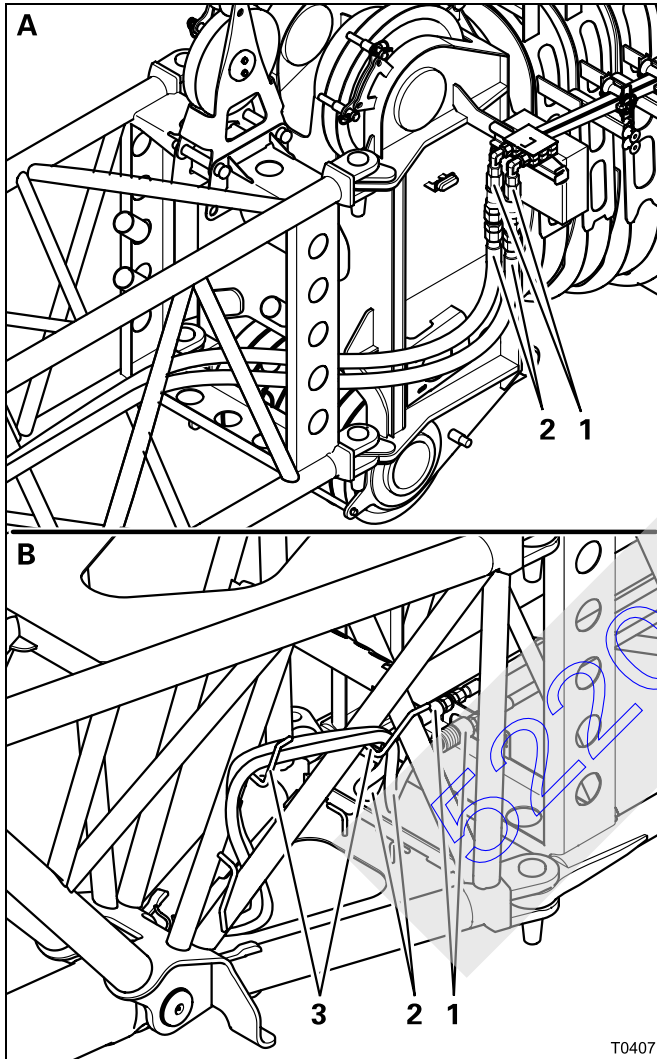

Establishing a connection

- (A) – If necessary, bring the connections (1) on the left side of the main boom head into the position for working with the lattice extension; see p. 3 - 40.
- Guide the hose lines (2) left out of section 3 and up to the main boom head.
- Remove the protective caps and connect the hose lines (2) to the connections (1).
- (B) – Remove the hose lines (2) from the clamps (3) in section 1.
- Remove the protective caps and connect the hose lines (2) to the connections (1).
- Secure the hose lines (2) to the clamps (3) to ensure that they do not hang down during operation.



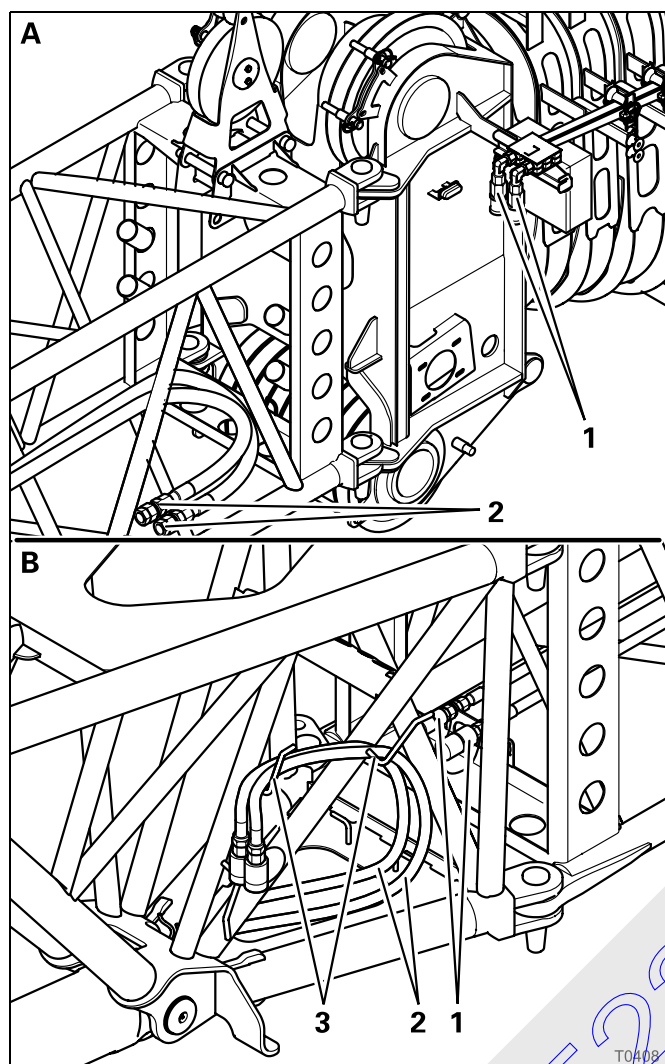

Disconnecting

- **(A)** – Disconnect the hose lines **(2)** from the connections **(1)**.
- Close the hose lines and the connections with the protective caps.
- Guide the hose lines **(2)** into section 3 and place them on the lower cross-strut.

In this position, the hose lines will not hang down while section 3 is being lifted.

- **(B)** – Disconnect the hose lines **(2)** from the connections **(1)**.
- Close the hose lines and the connections with the protective caps.
- Secure the hose lines **(2)** on the clamp **(3)** in section 1.

**On the 37 m
(121 ft) boom
extension**

All connections are made via quick-action couplings. The correct allocation is given using different forms and sizes.

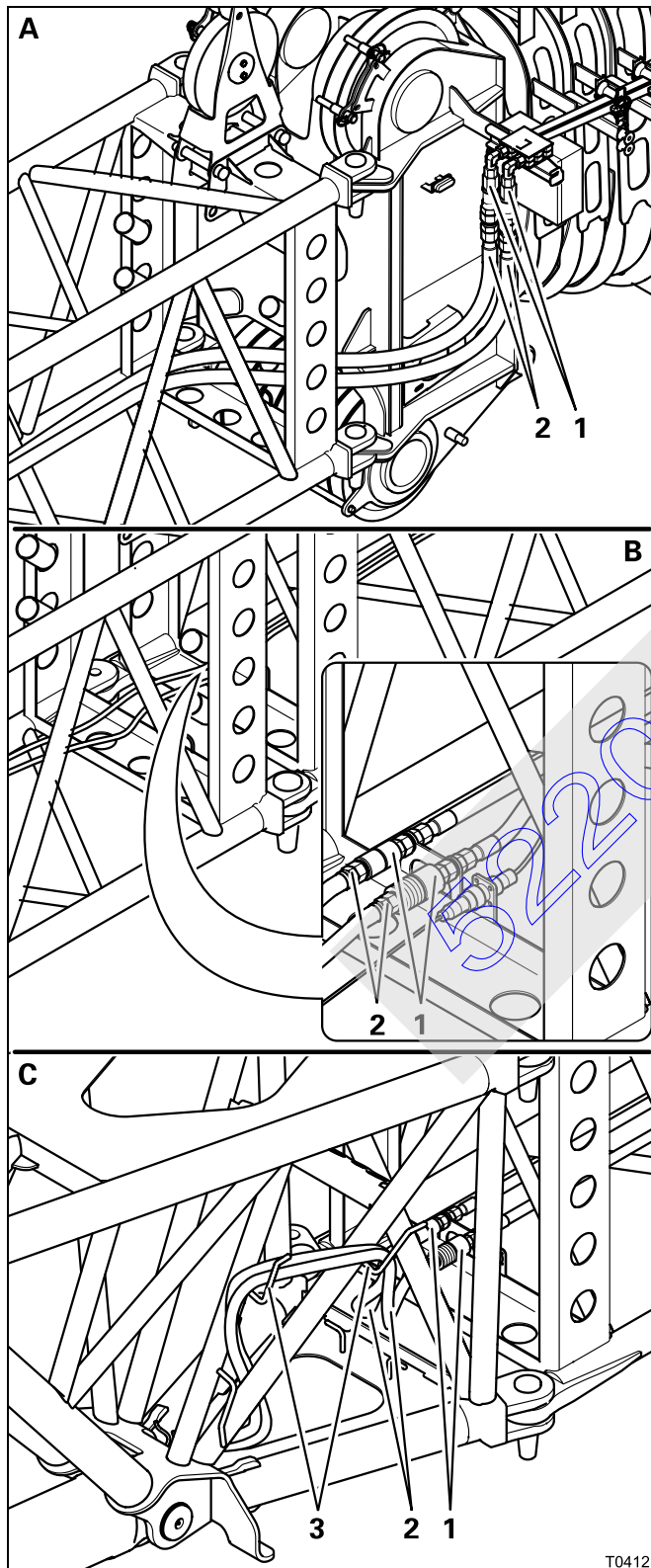

Establishing a connection

- (A) – If necessary, bring the connections (1) on the left side of the main boom head into the position for working with the lattice extension; p. 3 - 40.
- Guide the hose lines (2) left out of section 3 and up to the main boom head.
- Remove the protective caps and connect the hose lines (2) to the connections (1).
- (B) – Remove the protective caps and connect the hose lines (2) with the connections (1).
- (C) – Remove the hose lines (2) from the clamps (3) in section 1.
- Remove the protective caps and connect the hose lines (2) to the connections (1).
- Secure the hose lines (2) to the clamps (3) to ensure that they do not hang down during operation.



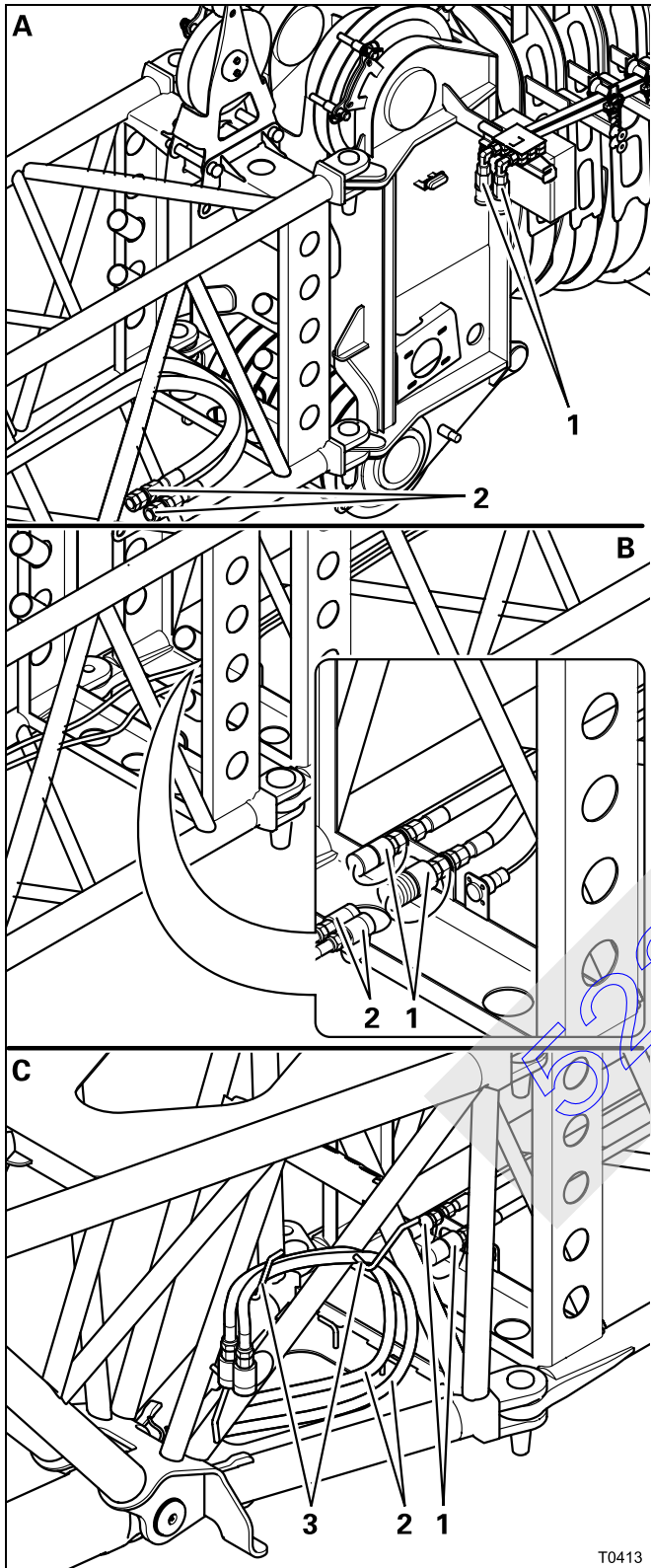

Disconnecting

- (A) – Disconnect the hose lines (2) from the connections (1).
- Close the hose lines and the connections with the protective caps.
- Guide the hose lines (2) into section 3 and place them on the lower cross-strut.

In this position, the hose lines will not hang down while section 3 is being lifted.

- (B) – Disconnect the hose lines (2) from the connections (1).
- Close the hose lines and the connections with the protective caps.

- (C) – Disconnect the hose lines (2) from the connections (1).
- Close the hose lines and the connections with the protective caps.
- Secure the hose lines (2) on the clamp (3) in section 1.

4.4.4

Electrical connection at the boom extension

On the 29 m (95 ft)
boom extension

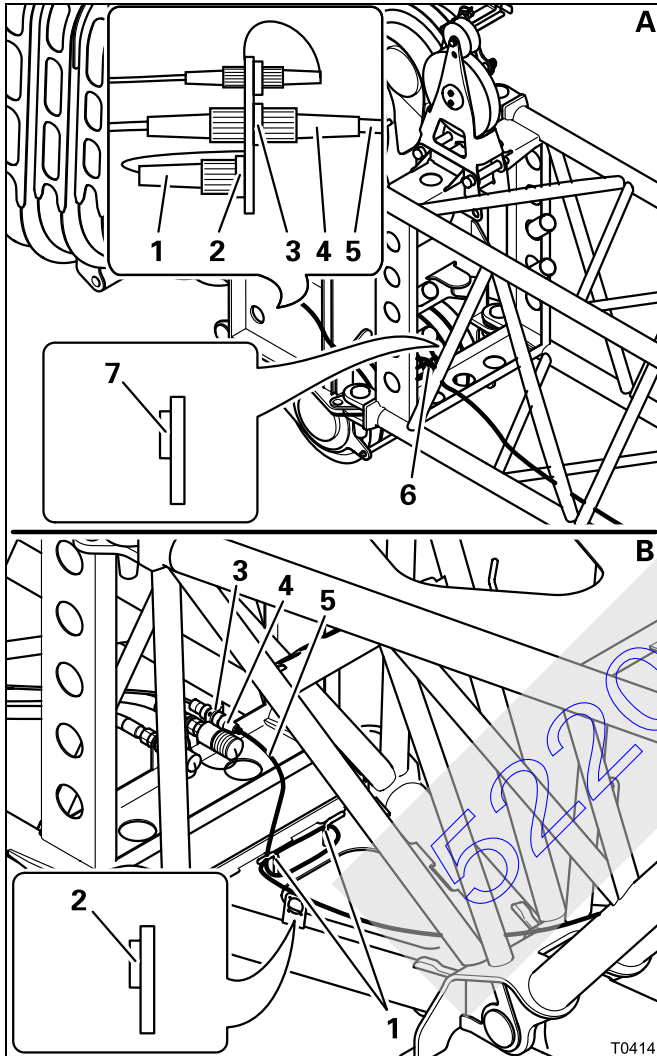

Establishing a connection

- (A) – Remove the bridging plug (1) from the socket (3) and insert it into the dummy socket (2).
 - Unwind the cable (5) from the holder (6).
 - Remove the bridging plug (4) from the dummy socket (7) and plug it into the socket (3).
 - Wind up the cable (5) far enough on the clamp (6) so that it does not hang down.
-
- (B) – Remove the protective cap from the socket (3).
 - Unwind the cable (5) from the holder (1).
 - Remove the plug (4) from the dummy socket (2) and plug it into the socket (3).
 - Wind up the cable (4) far enough on the clamp (1) so that it does not hang down.



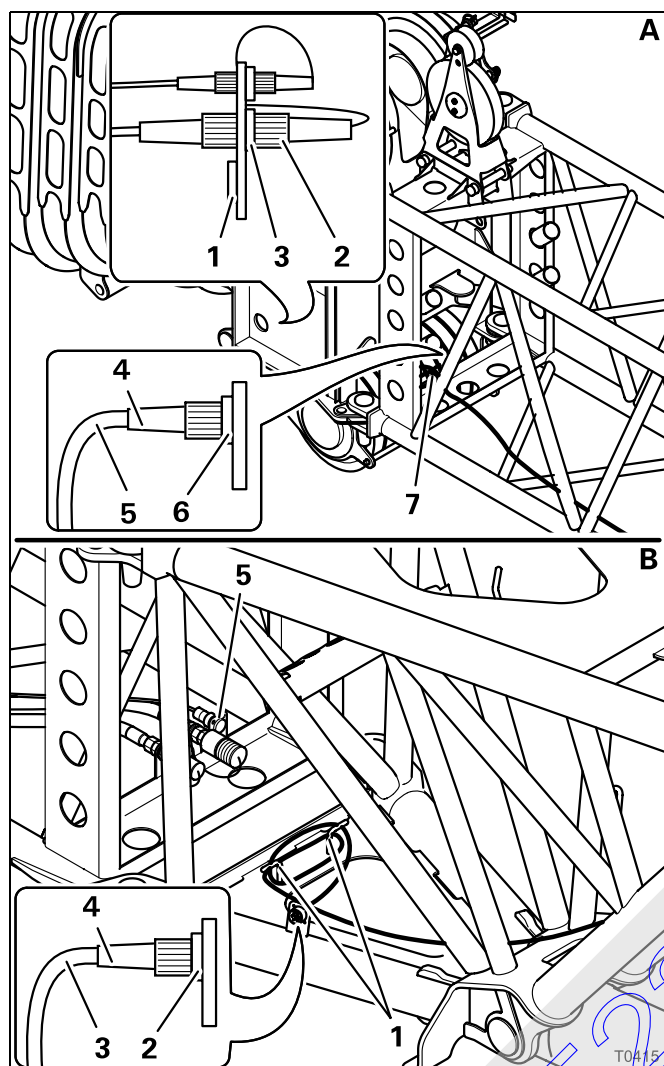

Disconnecting

- **(A)** – Remove the plug (4) from the socket (3) and insert it into the dummy socket (6).
 - Wind the cable (5) onto the holder (7).
 - Remove the bridging plug (2) from the dummy socket (1) and plug it into the socket (3).
-
- **(B)** – Remove the plug (4) from the socket (5) and insert it into the dummy socket (2).
 - Wind up the cable (3) far enough on the clamp (1) so that it does not hang down.
 - Cover the socket (5) with the protective cap.

**On the 37 m
(121 ft) boom
extension**

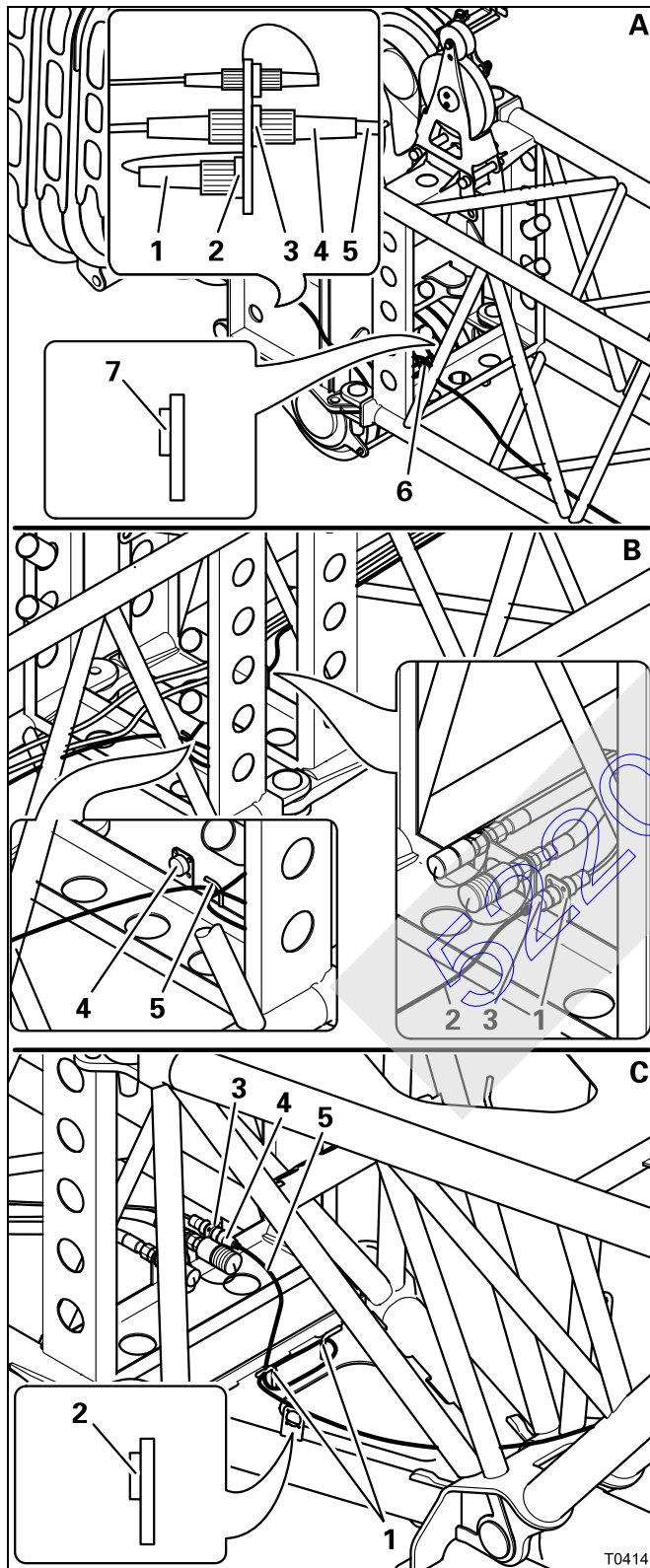

Establishing a connection

- (A) – Remove the bridging plug (1) from the socket (3) and insert it into the dummy socket (2).
 - Unwind the cable (5) from the holder (6).
 - Remove the bridging plug (4) from the dummy socket (7) and plug it into the socket (3).
 - Wind up the cable (5) far enough on the clamp (6) so that it does not hang down.
-
- (B) – Remove the protective cap from the socket (1).
 - Unwind the cable (2) from the holder (5).
 - Remove the plug (3) from the dummy socket (4) and plug it into the socket (1).
 - Wind up the cable (2) far enough on the clamp (5) so that it does not hang down.
-
- (C) – Remove the protective cap from the socket (3).
 - Unwind the cable (5) from the holder (1).
 - Remove the plug (4) from the dummy socket (2) and plug it into the socket (3).
 - Wind up the cable (4) far enough on the clamp (1) so that it does not hang down.



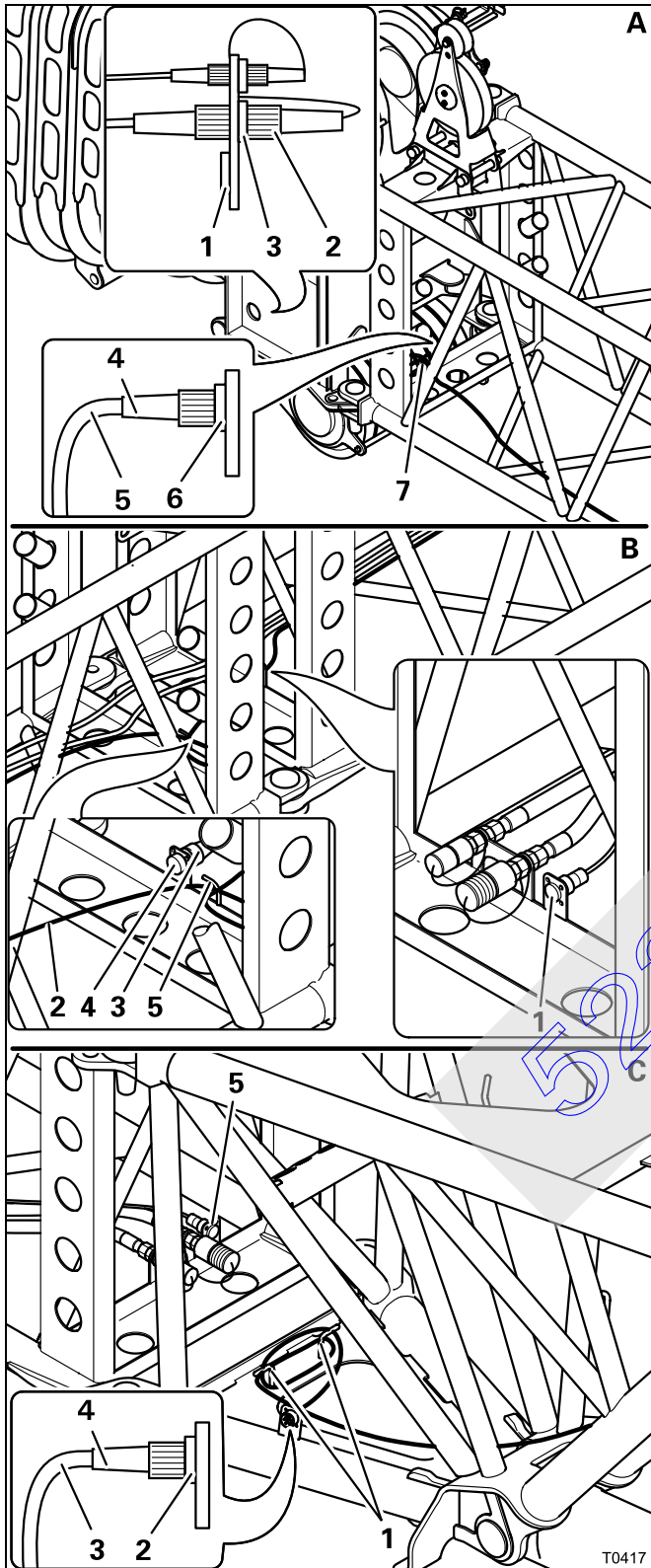

Disconnecting

- (A) – Remove the plug (4) from the socket (3) and insert it into the dummy socket (6).
- Wind the cable (5) onto the holder (7).
- Remove the bridging plug (2) from the dummy socket (1) and plug it into the socket (3).

- (B) – Remove the plug (3) from the socket (1) and insert it into the dummy socket (4) .
- Cover the socket (1) with the protective cap.
- Wind up the cable (2) far enough on the clamp (5) so that it does not hang down.

- (C) – Remove the plug (4) from the socket (5) and insert it into the dummy socket (2).
- Wind up the cable (3) far enough on the clamp (1) so that it does not hang down.
- Cover the socket (5) with the protective cap.

T0417

4.4.5

Fold in/fold out the deflection sheave on section 3

This section describes only the folding in and out of the deflection sheave in section 3. For folding the deflection sheaves on section 1 in and out;
▣▣▣▣▶ *Folding deflection sheave out/in*, p. 3 - 77

For operation with the 29 m (95 ft)-boom extension or the 37 m (121 ft) boom extension, you must fold out the deflection sheave on section 3.

You must fold the deflection sheave in for transport.

Folding out deflection sheave

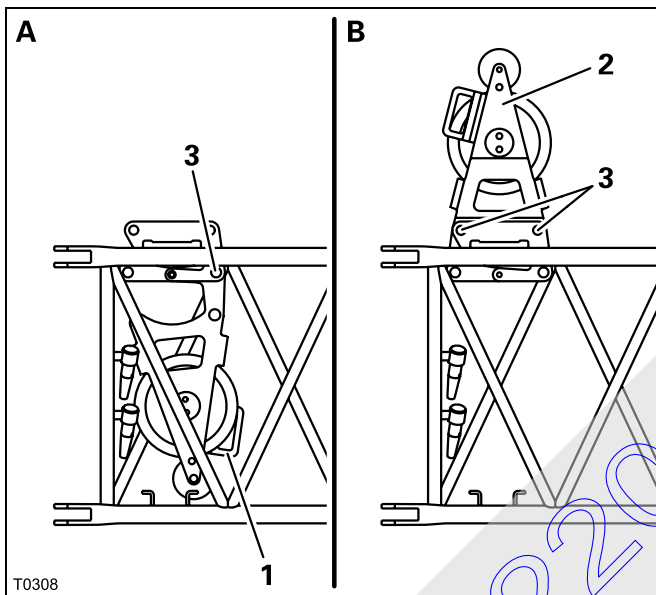

- (A) – Loosen the retaining pins from the pins (3).
- Hold the deflection sheave by the handle (1) and pull out the pin (3).
- (B) – Fold the deflection sheave (2) upwards and fasten it in this position with the pins (3).
- Secure the pins (3) using the retaining pins.

Folding in deflection sheave

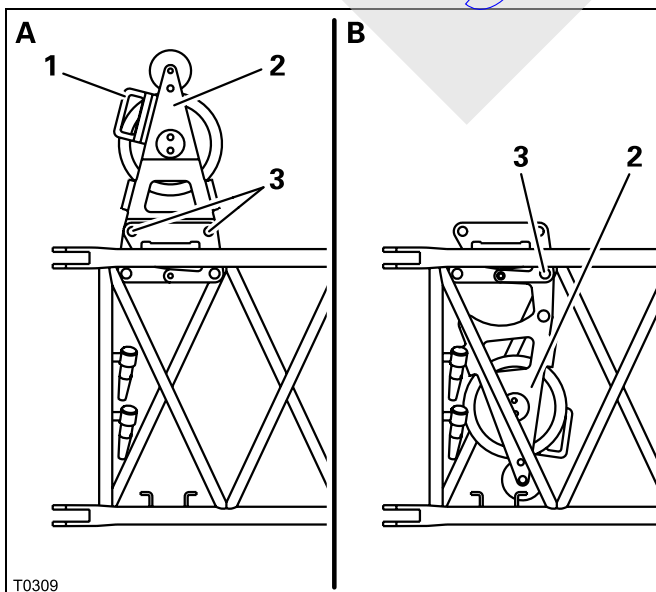

- (A) – Loosen the retaining pins from the pins (3).
- Hold the deflection sheave by the handle (1) and pull out the pins (3).
- (B) – Fold the deflection sheave (2) downwards and fasten it in this position with the pins (3).
- Secure the pins (3) using the retaining pins.

4.4.6

Positioning/removing the hoist rope



Risk of accidents due to falling parts

Always secure the hoist rope holding rollers and rods with retaining pins. This prevents elements from coming loose, falling down and injuring people.

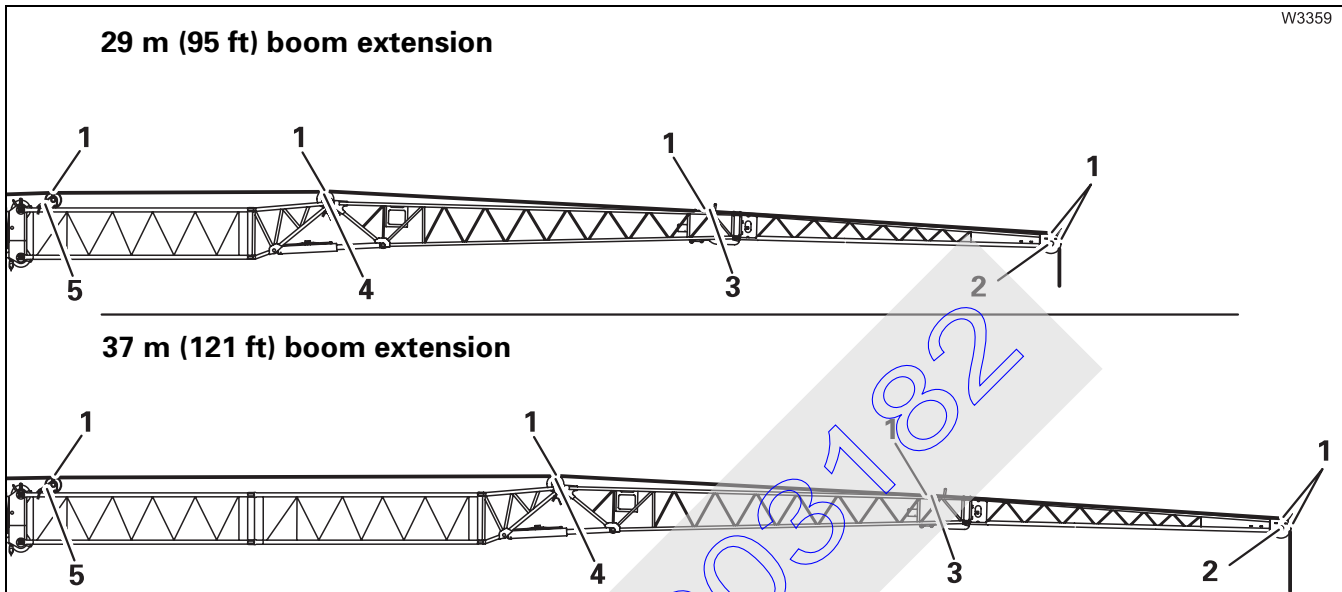





Positioning the hoist rope

- Remove the hoist rope holding rollers (1).
- Guide the hoist rope over the deflection sheaves (5), (4), (3) and over the head sheave (2) to section 1 or section 2.
- Put all hoist rope holding rollers (1) back in place and secure them with retaining pins.
- Install the hook tackle or the hook block. The hoist rope can only be reeved once on the boom extension; p. 4 - 28.

Removing the hoist rope

- Unreeve the hook block.
- Remove the hoist rope holding rollers (1).
- Take the hoist rope off the head sheave (2) and the deflection sheaves (5), (4), (3) and place it onto the ground on the left side.
- Put all hoist rope holding rollers (1) back in place and secure them with retaining pins.

Possible reeving methods The hoist rope may be reeved a maximum of 1 fall.

	<p>1-sheave hook block Maximum lifting capacity of the hook block 32 t (70 000 lbs) Maximum lifting capacity with the GMK 5220: A For reeving 1-fall 9.5 t (16 000 lbs)</p>	
<hr/>		
	<p>Hook tackle Maximum lifting capacity of the hook tackle 12 t (17 600 lbs) Maximum lifting capacity with the GMK 5220: A For reeving 1-fall 9.5 t (16 000 lbs)</p>	

W6614

52203182

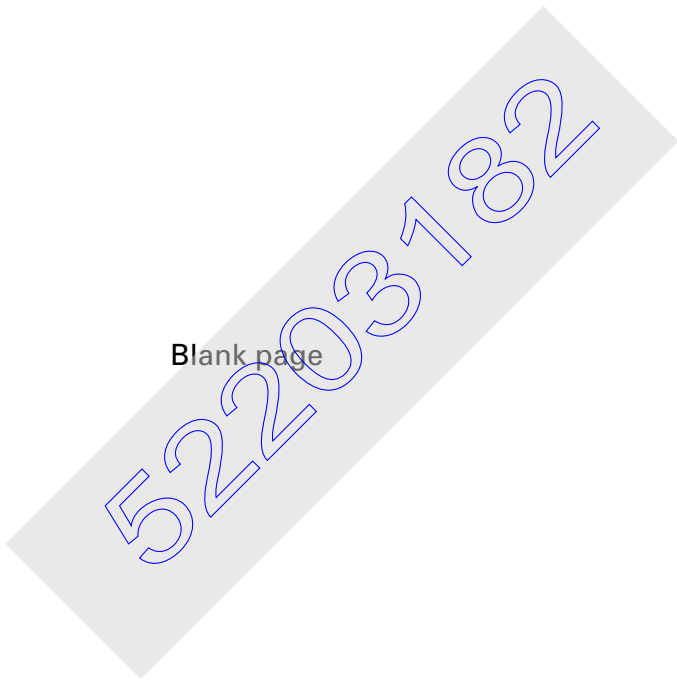

4.5

Working with the boom extension



When operating the lattice extension or the boom extension, the speed for the different power units is limited to 70%, *Operating instructions GMK 5220 – Crane operation – Adjusting power unit speeds.*



Risk of overturning when working with the boom extension

No hook block may be reeved on the main boom during operation with the boom extension.

It is not permitted to work with the main boom if the boom extension is rigged.



Risk of accidents due to overloading

Lifting a load with two hooks when the boom extension is rigged is not permitted.

The hoisting, lowering, slewing, derricking and telescoping movements are carried out in the same way as when operating with the main boom.

The same information that you will also need for a rigged or installed lattice extension applies:

- Setting, p. 3 - 96,*
- Telescoping with rigged lattice extension, p. 3 - 99,*
- Information about the SLI shutdown, p. 3 - 100,*
- Procedure if the permissible wind speed is exceeded, p. 3 - 101.*

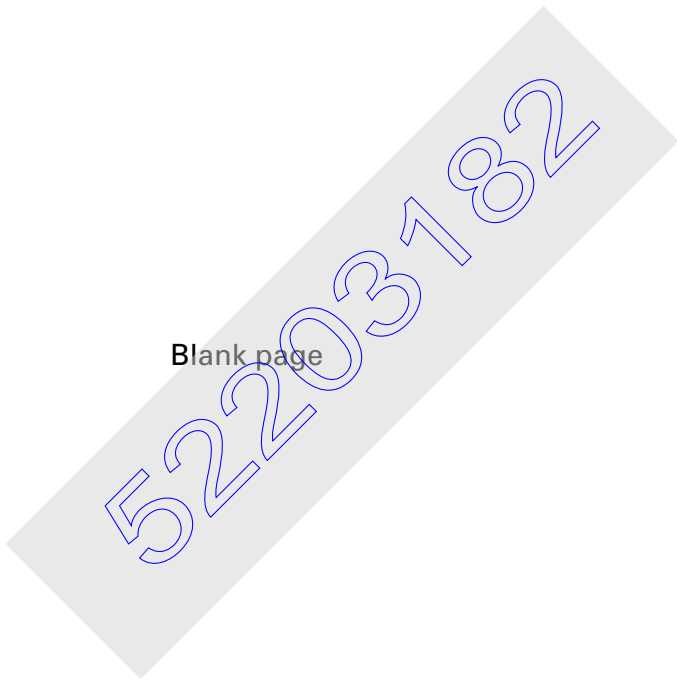

4.6

Driving with rigged truck crane and rigged boom extension

This section describes how you can move the truck crane with installed counterweight and rigged boom extension (e.g if, because of lack of space, the boom extension cannot be directly installed at the site).



Risk of accidents when driving with a lifted load

When using a boom extension, moving the truck crane with a load on the hook is not permitted.

Put the load down before you move the truck crane.



Risk of accidents due to swinging hook block

Secure the hook block against swinging when driving the rigged truck crane.



Risk of overturning when rotating the superstructure

When driving the rigged truck crane, the slewing gear brake must be closed.



Danger of accidents by being unable to overview the entire truck crane!

While driving the equipped truck crane, always stay in visual or radio contact with a banksman who can observe the parts which you cannot see.

This prevent accidents resulting from collisions with persons, other construction equipment, ledges of buildings, cables or other objects.



Risk of accidents when driving from the crane cab

Before moving the truck crane from the crane cab, observe all instructions in the *Operating instructions GMK 5220* and set the rigging code described there for free-standing works;  *Operating instructions GMK 5220 – Driving the truck crane from the crane cabin.*

4.6.1

Driving route

The route must be along a flat, even surface. The level adjustment system cannot compensate for uneven surfaces. If the surface pressure of the tyres exceeds the permissible load on the ground, the surface area of the tyres must be increased using packing made of a stable material (e.g. wooden planks).



Risk of damage to tyres

Check the pressure in the tyres before moving the rigged truck crane.

The truck crane may be moved only if tyre pressures are at the prescribed levels  *Operating instructions GMK 5220 – Part 1, Driving – Technical data.*

Do not reduce the tyre pressure.

52203182

4.6.2

Boom positions and axle loads

The truck crane may only be moved if certain prerequisites are met. The main boom and the lattice extension must be moved to specified positions, depending on the counterweight installed.



Risk of damage to the axle lines

Always move the main boom and the lattice extension to the specified position before you move the rigged truck crane. Positions which deviate from the specified position cause impermissible loads on the axle lines.

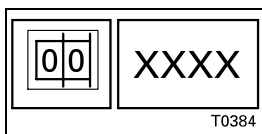

- Enter the SLI code according to the *lifting capacity table* for the actual rigging mode of the truck crane with the rigged boom extension.

- Move the main boom and the lattice extension into the prescribed positions. The prescribed boom position can be found in the following tables.



Danger of accidents if SLI is overridden!

Always set the SLI code corresponding to the current rigging mode when you derrick the main boom or lattice extension into the prescribed position. Do not override the SLI; the prescribed positions in the following tables are all within the areas which are permitted according to the *Lifting capacity tables*.

The truck crane operates without overload protection when the SLI is overridden!

Notes on the tables

The axle loads specified in the following tables refer to a driving mode with the basic unit.

The following footnotes apply in all tables:

- 1) Boom position to the rear: 0° position, boom over rear edge of truck crane
- Boom position to the front: 180° position, boom over driver's cab
- 2) Axle load to the front: on the 1st to 3rd axle lines, as applicable
- Axle load to the rear: on the 4th and 5th axle lines, as applicable



29 m (95 ft) boom extension



All the axle loads in the following table apply for reeved **hook tackle** (weight 300 kg (660 lbs)).

The maximum axle load specified in the table is reached at a main boom angle of either x° or y° . When the maximum axle load is reached e.g. to the front, the axle load to the rear is under the specified maximum axle load. At main boom angles between x° and y° , the axle loads are under the specified maximum axle loads.

Counterweight in t (lbs)	Telescoping Telescopic section I-II-III-IV-V-VI	Main boom angle x° to y°	Lattice inclination in $^\circ$	Main boom position ¹⁾	Maximum axle load ²⁾ in t (x 1000 lbs)	
					front	rear
31.0 (68 300)	0 - 0 - 0 - 0 - 0 - 0	50 - 80	5	rear	20,5 (45.2)	27,0 (59.5)
36.0 (79 300)	0 - 0 - 0 - 0 - 0 - 0	50 - 80	5	rear	22,0 (48.5)	27,0 (59.5)
41.0 (90 300)	0 - 0 - 0 - 0 - 0 - 0	50 - 80	5	rear	24,0 (52.9)	27,5 (60.6)
46.0 (101 400)	0 - 0 - 0 - 0 - 0 - 0	50 - 80	5	rear	25,5 (56.2)	27,5 (60.6)
51.0 (112 400)	0 - 0 - 0 - 0 - 0 - 0	50 - 80	5	rear	27,0 (59.5)	27,5 (60.6)
71.0 (165 500)	0 - 0 - 0 - 0 - 0 - 0	50 - 55	5	rear	28,0 (61.7)	28,0 (61.7)
77.0 (169 700)	Driving with rigged truck crane not permitted . Unrig the counterweight combination to 71.0 t (165 500 lbs).					

1), 2) Notes on the tables, p. 4 - 34

37 m (121 ft) boom extension

All the axle loads in the following table apply for reeved **hook tackle** (weight 300 kg (660 lbs)).



The maximum axle load specified in the table is reached at a main boom angle of either x° or y° . When the maximum axle load is reached e.g. to the front, the axle load to the rear is under the specified maximum axle load. At main boom angles between x° and y° , the axle loads are under the specified maximum axle loads.

Counterweight in t (lbs)	Telescoping Telescopic section I-II-III-IV-V-VI	Main boom angle x° to y°	Lattice inclination in $^\circ$	Main boom position ¹⁾	Maximum axle load ²⁾ in t (x 1000 lbs)	
					front	rear
31.0 (68 300)	0 - 0 - 0 - 0 - 0 - 0	55 - 80	5	rear	18,0 (39.7)	27,5 (60.6)
36.0 (79 300)	0 - 0 - 0 - 0 - 0 - 0	55 - 80	5	rear	22,0 (48.5)	27,5 (60.6)
41.0 (90 300)	0 - 0 - 0 - 0 - 0 - 0	55 - 80	5	rear	23,5 (51.8)	28,0 (61.7)
46.0 (101 400)	0 - 0 - 0 - 0 - 0 - 0	55 - 80	5	rear	25,0 (55.1)	28,0 (61.7)
51.0 (112 400)	0 - 0 - 0 - 0 - 0 - 0	55 - 80	5	rear	27,0 (59.5)	28,0 (61.7)
71.0 (165 500)	0 - 0 - 0 - 0 - 0 - 0	55 - 60	5	rear	28,0 (61.7)	28,0 (61.7)
77.0 (169 700)	Driving with rigged truck crane not permitted . Unrig the counterweight combination to 71.0 t (165 500 lbs).					

1), 2) Notes on the tables, p. 4 - 34

4.6.3 Driving the rigged crane

When driving with a rigged boom extension, proceed in the same way as for driving with a rigged lattice extension;  p. 3 - 116.

4.7 Maintenance work

4.7.1 Maintenance work M1, monthly



For lubricating the pins, use the same grease as stated in the *Maintenance manual* for lubricating attach pins and socket pins;  *Maintenance manual* GMK 5220, *Maintenance overview – M1 maintenance plan*.

- Lubricate all connection pins, securing pins and locking pins.



The maintenance interval applies to average operation. Also lubricate the pins after high-pressure cleaning and generally at an interval that will prevent them getting dry.

52203182

5 Auxiliary single-sheave boom top

5.1	Identification	5 - 1
5.2	Installing/removing auxiliary single-sheave boom top	5 - 3
5.2.1	Installing the auxiliary single-sheave boom top	5 - 3
5.2.2	Dismantling the auxiliary single-sheave boom top	5 - 4
5.3	Rigging the auxiliary single-sheave boom top	5 - 5
5.3.1	Rigging in transport position	5 - 5
5.3.2	Rigging in working position	5 - 6
5.3.3	Attaching and removing the hoist rope	5 - 7
5.3.4	Setting the SLI	5 - 8
5.3.5	Lifting limit switch and anemometer	5 - 9
5.4	Operation with the auxiliary single-sheave boom top	5 - 11
5.5	Turning loads with the auxiliary single-sheave boom top	5 - 13
5.5.1	Prerequisites	5 - 13
5.5.2	Setting the SLI	5 - 14
5.5.3	Turning a load	5 - 16
5.6	Driving with rigged truck crane and rigged auxiliary single-sheave boom top .	5 - 18

52203182

52203182

5

Auxiliary single-sheave boom top

5.1

Identification

The auxiliary single-sheave boom top is designed for the truck crane it was delivered with. It has the same serial number as the truck crane.



Risk of accidents during operation with non-modified auxiliary single-sheave boom top

Operate the truck crane only with the auxiliary single-sheave boom top that has the identical serial number.

The SLI is only set for this auxiliary single-sheave boom top. This prevents malfunctions and damage.

If you wish to use the auxiliary single-sheave boom top on several GROVE truck cranes, it needs to be adapted to the corresponding crane and marked with all the serial numbers.



Risk of accidents if not adjusted correctly

The adjustment of the auxiliary single-sheave boom top may only be carried out by *CraneCARE*.

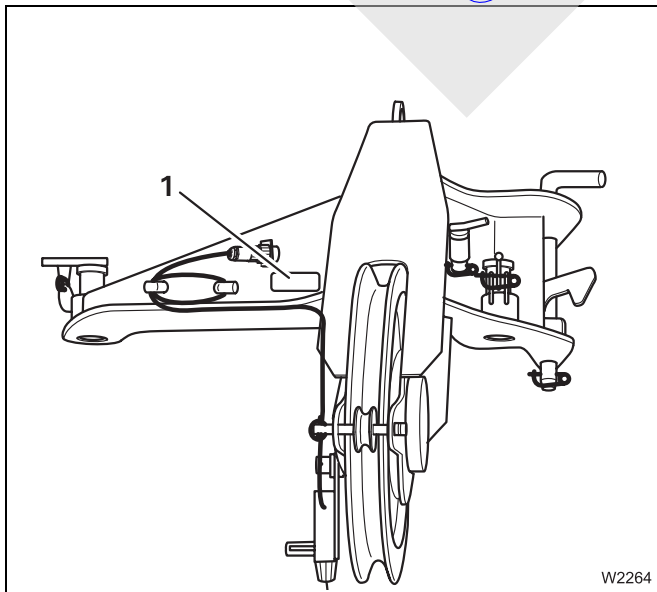

The serial number (1) can be found on the front of the auxiliary single-sheave boom top.

Blank page

52203182

5.2

Installing/removing auxiliary single-sheave boom top



Risk of accidents if the auxiliary single-sheave boom top should fall off
Attach the auxiliary single-sheave boom top only at the designated slinging point.
Use only lifting gear with sufficient lifting capacity; *Auxiliary single-sheave boom top*, p. 2 - 2.

5.2.1

Installing the auxiliary single-sheave boom top

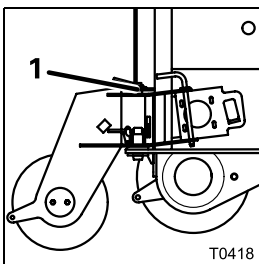

- Attach the auxiliary single-sheave boom top at the slinging point (1).
- Hoist the auxiliary single-sheave boom top in front of the main boom head.

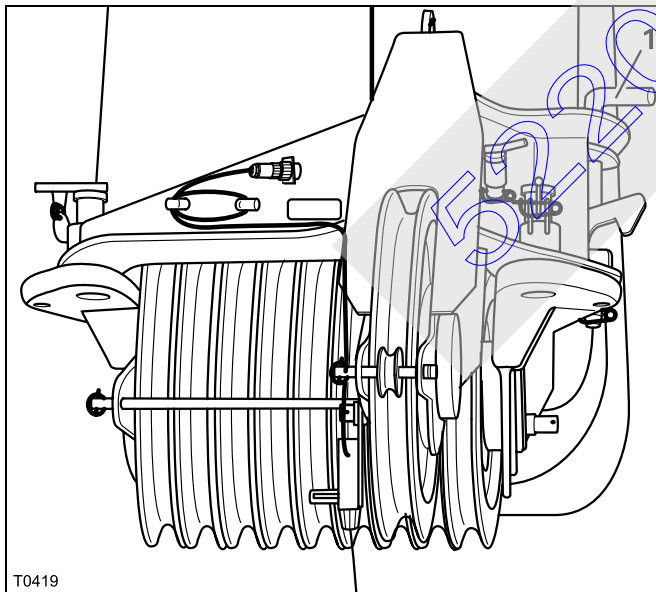

- Plug the pin (1) into the bearing point and secure it with the retaining pin.
- Depending on the application, bring the auxiliary single-sheave boom top into transport position or working position;
 Rigging in transport position, p. 5 - 5,
 Rigging in working position, p. 5 - 6.

5.2.2

Dismantling the auxiliary single-sheave boom top

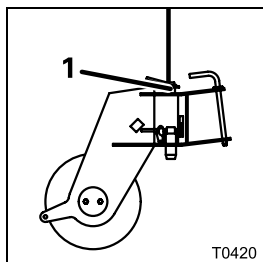

- Attach the auxiliary single-sheave boom top at the slinging point (1).
- Make sure that the electrical connections have been separated;  *Lifting limit switch and anemometer*, p. 5 - 9.

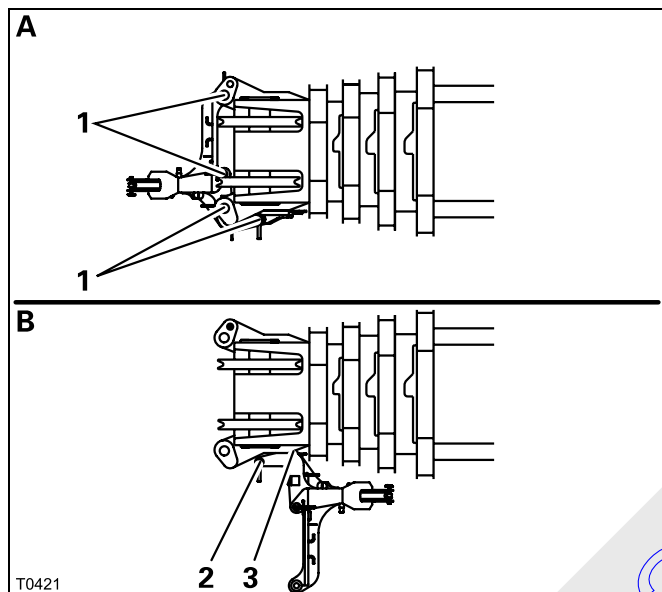

(A) – In the working position, the auxiliary single-sheave boom top is fastened with four pins (1).

- Remove the retaining pins and draw all of the pins (1) out of the bore holes.

(B) – In the transport position, the auxiliary single-sheave boom top is fastened with one pin (2) and hook (3).

- Release the retaining pin and remove the pin (2) from the bore hole.
- Pull the lever (3) downwards until the hook is completely released.

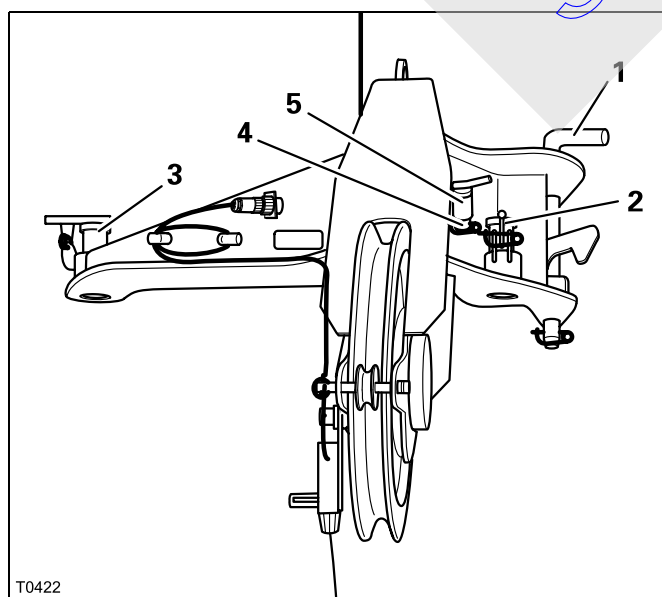

- Plug the pin (1) into the bearing point and secure it with the retaining pin.
- Secure the pins (2) and (3) in their holders.
- Plug the pins (4) into the holder (5) and secure it with a retaining pin.

5.3 Rigging the auxiliary single-sheave boom top

5.3.1 Rigging in transport position

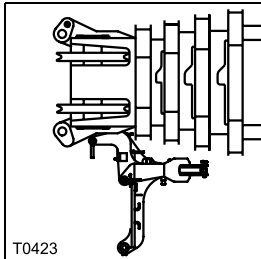

In the transport position, the auxiliary single-sheave boom top is folded to the left on the main boom.

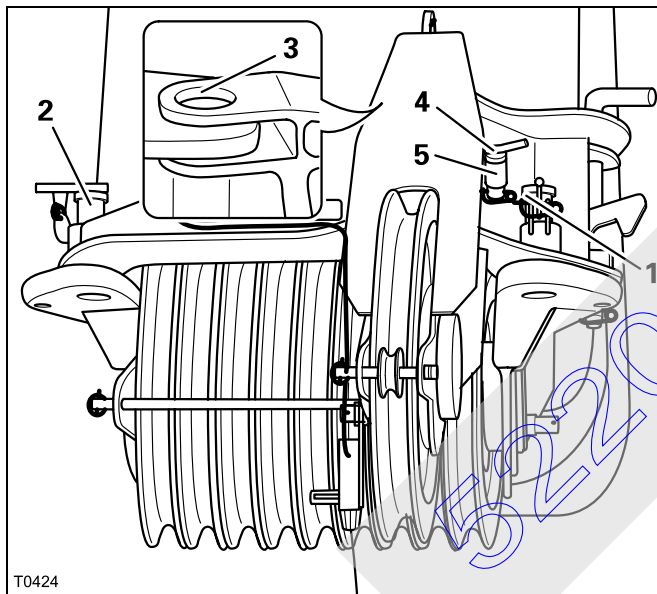

- Make sure that the electrical connections have been separated;  *Lifting limit switch and anemometer*, p. 5 - 9.
- Remove pins (1) and (2) from the bearing points and secure them.
- Withdraw the pin (4) from the bearing point (3) and insert it into the holder (5). Secure it.
- Swing the auxiliary single-sheave boom top to its full extent towards the main boom.

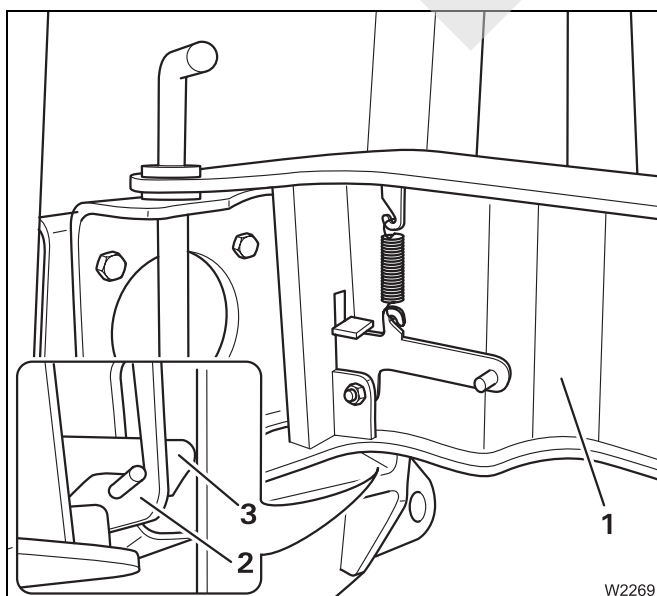

- Also make sure that the hook (3) on the auxiliary single-sheave boom top (1) is mechanically locked correctly in the latch (2) on the main boom.

The auxiliary single-sheave boom top is now in transport position.

5.3.2 Rigging in working position

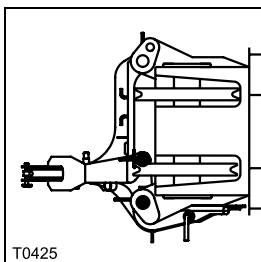

In the working position, the auxiliary single-sheave boom top is locked in front of the main boom.

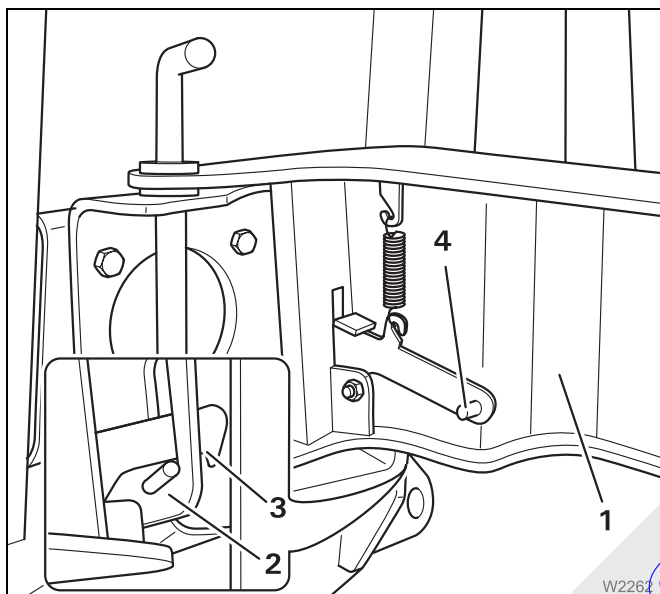

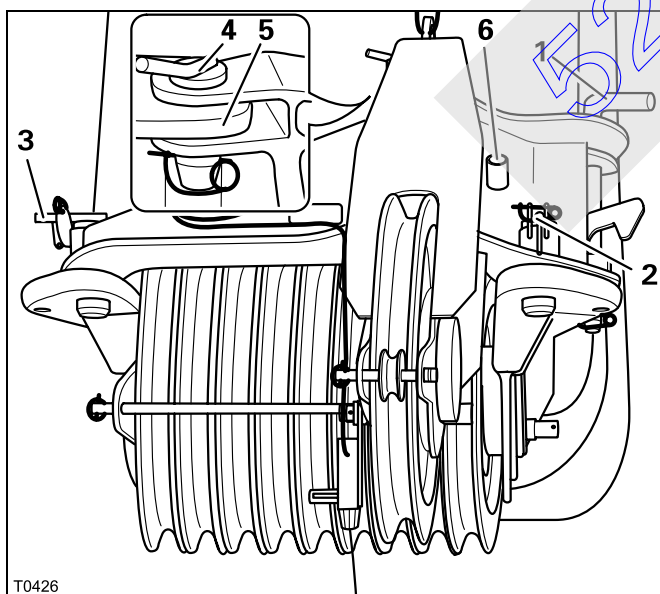

- Pull the lever (4) on the auxiliary single-sheave boom top (1) downwards until the hook (3) is completely released from the latch (2) on the main boom.
- Swing the auxiliary single-sheave boom top in front of the main boom head.



- Plug the pin (4) of the holder (6) into the bearing point (5) and secure it.
- Loosen the pins (2) and (3) in their holders.
- Plug the pins (2) and (3) through the bearing points on the main boom head and secure them.

The auxiliary single-sheave boom top is now in working position.

- Make the electrical connection for the lifting limit switch;  *Lifting limit switch and anemometer, p. 5 - 9.*
- Install the anemometer;  *Lifting limit switch and anemometer, p. 5 - 9.*

5.3.3 Attaching and removing the hoist rope

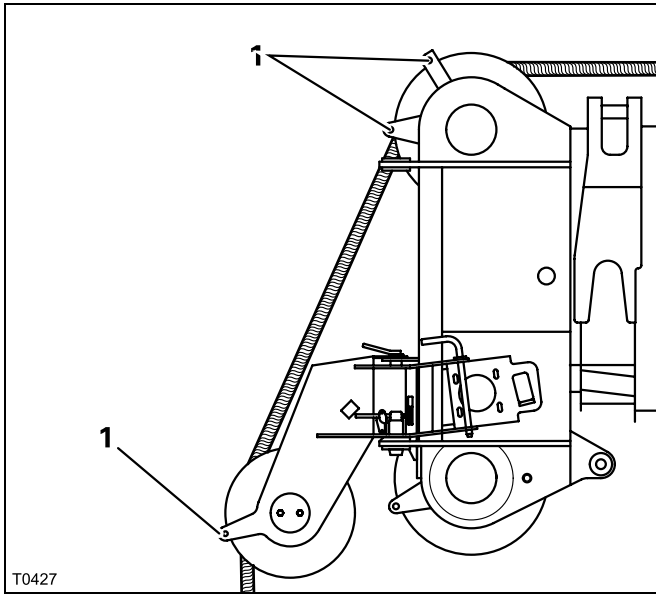

- Remove the cable holding rods (1) from the head of the main boom and from the auxiliary single-sheave boom top.
- When reeving, guide the hoist rope over the left head sheave of the main boom.
- Insert the rope holding rod into the appropriate bore holes and secure them with the corresponding retaining pins.
- Fasten the rope end clamp on the hook tackle or the hook block.

Reverse the sequence of operations to remove the hoist rope before slewing the auxiliary boom top into transport position.

Possible reeving methods

The hoist rope may be reeved at a maximum of 1-fall.

	<p>1-sheave hook block Max. lifting capacity of the hook block Max. lifting capacity with the GMK 5220:</p>	<p>32 t (70 500 lbs)</p>	
<p>A for 1-fall reeving</p>		<p>9.5 t (20 900 lbs)</p>	
<hr/>			
	<p>Hook tackle Max. lifting capacity of the hook tackle Max. lifting capacity with the GMK 5220:</p>	<p>12 t (26 600 lbs)</p>	
<p>A for 1-fall reeving</p>		<p>9.5 t (20 900 lbs)</p>	

5.3.4

Setting the SLI

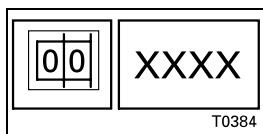

- On the SLI, enter the actual rigging mode for operation with the **main boom**. Use either the corresponding SLI code in accordance with the *Lifting capacity table* or via individual components.

In this case, the values given in the corresponding *Lifting capacity tables* for the lifting capacities decrease.

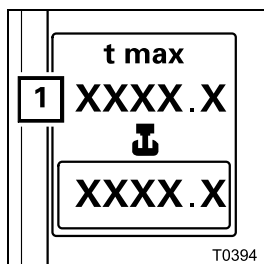

The *Maximum load* display (1) does **not** show the decreased values.

The SLI also takes into account the load moment affected by the rigged auxiliary single-sheave boom top and will correspondingly switch off earlier.

52203182

5.3.5

Lifting limit switch and anemometer

Lifting limit switch For operation

For each reeved hoist rope, a lifting limit switch must be installed. Information on this can be found in the *Operating instructions GMK 5220, Part 2 Crane operation – Rigging work – Installing/removing lifting limit switch.*

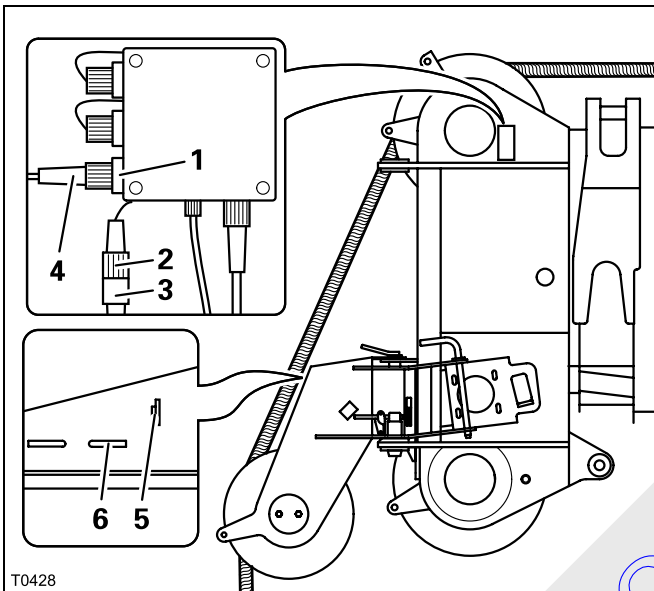

On the left side

- Remove the bridging plug (3) from the socket (1) and plug it into the dummy socket (2).
- Unwind the cable from the clamp (6).
- Remove the bridging plug (4) from the dummy socket (5) and plug it into the socket (1).
- Wind up the connecting cable of the plug (4) far enough on the clamp (6) so that it does not hang down.
- Install the lifting limit switch weight and lay it around the hoist rope; *Operating instructions GMK 5220.*

On the right side

If, additionally, a hook block is reeved on the main boom, connect the second lifting limit switch to the socket on the right side of the main boom head; *Operating instructions GMK 5220.*

If no hook block is reeved on the main boom, the bridging plug must be plugged into the socket that is not used; *Operating instructions GMK 5220.*



For removal

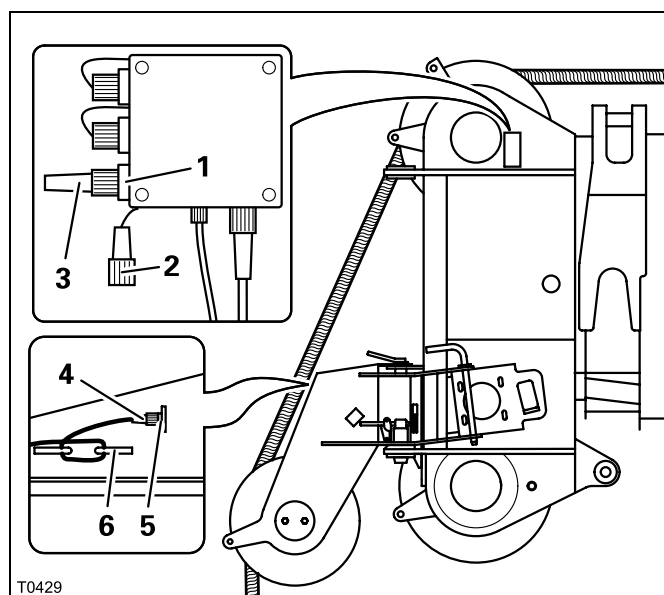

On the left side

- Remove the bridging plug (4) from the socket (1) and plug it into the dummy socket (5).
- Wind the connecting cable of the plug (4) onto the holder (6).
- Remove the bridging plug (3) from the dummy socket (2) and plug it into the socket (1).

On the right side

If no hook block is reeved on the main boom, the bridging plug must be plugged into the socket that is not used; ■■■► *Operating instructions GMK 5220.*

Anemometer

Installation and removal

You must install the anemometer for operation with the auxiliary single-sheave boom top.

You must remove the anemometer for driving on-road.

It is installed and removed in the same way as for operation with the main boom; ■■■► *Operating instructions GMK 5220.*



Risk of damage to the anemometer

Remove the anemometer for on-road driving.

That way you prevent the anemometer from being damaged by wind (e.g. by suction currents caused by oncoming traffic in tunnels).

5.4

Operation with the auxiliary single-sheave boom top

Operation with the auxiliary single-sheave boom top is carried out in the same way as operation with the main boom.

- The hoisting, lowering, slewing, derricking and telescoping movements are carried out in the same way as when operating with the main boom.
- When working with the auxiliary single-sheave boom top, SLI shutdowns may occur for the same reasons as when operating with the main boom.
 ▣▣▣▣▶ *Operating instructions GMK 5220 – Part 2 Crane operation – Crane operation.*
- Strong winds can result in the truck crane becoming overloaded. For this reason, closely observe the instructions contained in the the Section *Effect of wind on crane operation*, ▣▣▣▣▶ *Operating instructions GMK 5220, Part 2 – Crane operation.*

52203182

Blank page

52203182

5.5

Turning loads with the auxiliary single-sheave boom top

Two-hook operation is required for turning loads.

The only type of two-hook operation technically possible and protected by the SLI is described in this chapter using the turning of loads as an example.



Risk of accidents due to overloading

Lifting a load with two hooks is permitted only if the following instructions and illustrations are observed.

If these instructions are disregarded, accidents can occur due to individual parts of the truck crane being overloaded. The SLI then no longer provides protection.



Risk of accidents due to overloading

The load must always be lifted with the weakest part first (auxiliary single-sheave boom top).



For information on the position and function of the operating instruments required;  *Operating instructions GMK 5220 – Part 2 Crane operation – Operating elements.*

5.5.1

Prerequisites

The following description requires that:

- the main hoist rope is reeved on the main boom
- the auxiliary hoist rope is reeved on the auxiliary single-sheave boom top
- the lifting limit switches for both hoists are connected



Risk of accidents due to overloading

The reeving on the main boom must be the equal or greater than the reeving on the auxiliary single-sheave boom top.

The main hoist rope and the main hoist will become overloaded if this condition is not met.

5.5.2

Setting the SLI

You must enter the following settings on the SLI for two-hook operation:

- Enter the current reeving for the main and auxiliary hoist.
The values are stored and called up directly when switching hoists.
- Switch on operation with both hoists in such a way that the digit for the auxiliary hoist lights up on the *Hoists* indicator lamp.

Entering a reeving

You can enter the reeving for both hoists at any time, independent of which hoist is switched on.

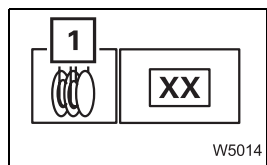

When the *Enter reeving* symbol (1) is shown without digits on the *Reeving* display, you must switch on input mode first:

Press the button next to the symbol (1) once.

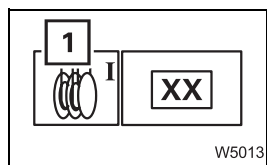

The symbol (1) will be highlighted in green and input mode is enabled. A digit also now appears beside the symbol, e.g. I.

This digit shows which hoist the displayed reeving applies to:

- Digit I: Main hoist
Digit II: Auxiliary hoist

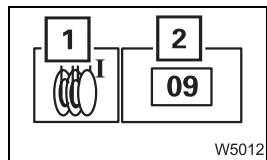

- In the *Reeving* display (2), enter the current number of runs of the reeved hoist rope for the hoist shown (↑ ↓), e.g. **09**, for the main hoist.

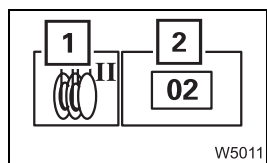

- Press the button next to the symbol *Enter reeving* (1) repeatedly until the digit for the other hoist is shown (e.g. II for the auxiliary hoist).
- In the *Reeving* display (2), enter the current number of runs of the reeved hoist rope for this hoist (↑ ↓), e.g. **02** for the auxiliary hoist.

Now the reevings have been entered for both hoists.

Setting the SLI to the auxiliary hoist

The SLI always takes into account the reeving entered for the hoist which is displayed at the *Hoists* indicator lamps. For turning loads, the SLI must take the auxiliary hoist and its reeving into account and both hoists must be switched on. To access this SLI setting, proceed as follows:

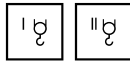

- Switch off both hoists.
To do so, press the bottom part of both rocker buttons *Main hoist on/off* and *Auxiliary hoist on/off* once.
The indicator lamps in the rocker buttons are dimly lit.



- Switch on the auxiliary hoist.
To do so, press the bottom part of the *Auxiliary hoist on/off* rocker button once. The indicator lamp in the rocker button lights up brightly.

At the *Hoists* indicator lamps, lamp II for the auxiliary hoist now lights up.

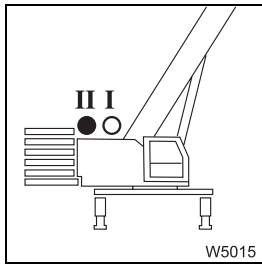

- Now switch on the main hoist.
To do so, press the bottom part of the *Main hoist on/off* rocker button once. The indicator lamp in the rocker button lights up brightly.

At the *Hoists* indicator lamps, lamp I for the main hoist now flashes additionally.

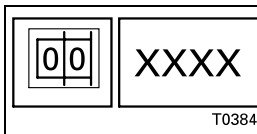
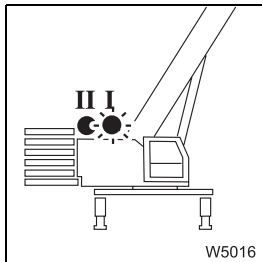

- On the SLI, select the current rigging mode with the rigged lattice extension or enter the appropriate SLI code according to the *Lifting capacity table*.

The SLI is now set for two-hook operation. It now takes into account:

- The reeving for the auxiliary hoist and
- the lifting capacity tables for the heavy load lattice extension.



In two-hook operation, the load measurement is taken using the pressure in the derricking cylinder. The loads detailed in the *Lifting capacity table* then decrease by the weight of both reeved hook blocks.

5.5.3

Turning a load

Carry out the load turning only as it is described in this section.



Risk of accidents due to overloading

Keep the acceleration forces as low as possible during two-hook operation. For this reason, move the load at the lowest possible speed.



As soon as the load is on two hooks, there will be slight differences in the *Current load* display. However, these deviations are still on the safe side as regards an SLI shutdown.

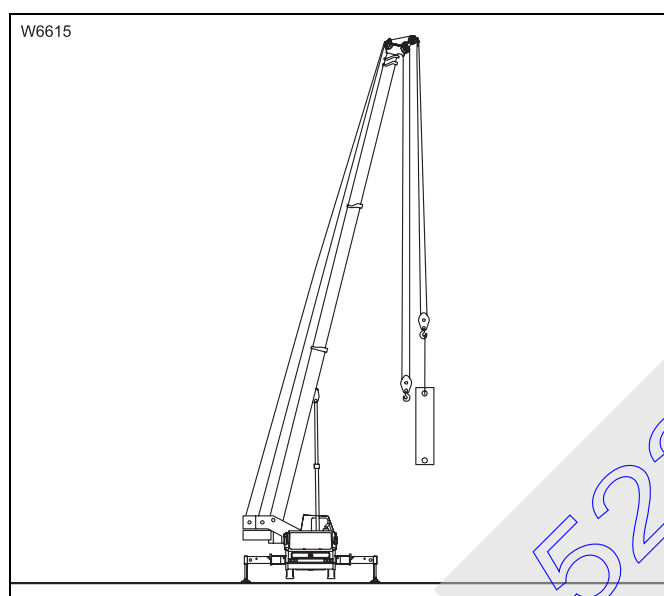

- Initially, only sling the load to the hook block of the auxiliary single-sheave boom top (rope of the auxiliary hoist).
- Lift the load completely off the ground with the auxiliary single-sheave boom top.

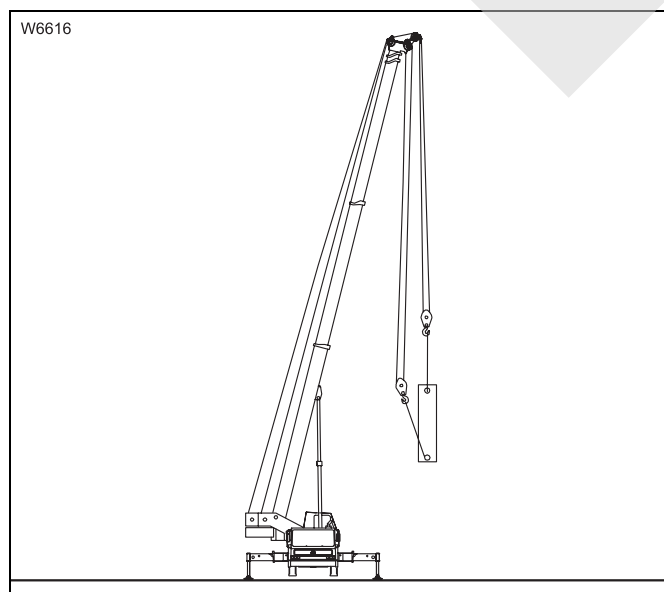

- Only now should you attach the load to the hook block of the main boom as well (main hoist rope).

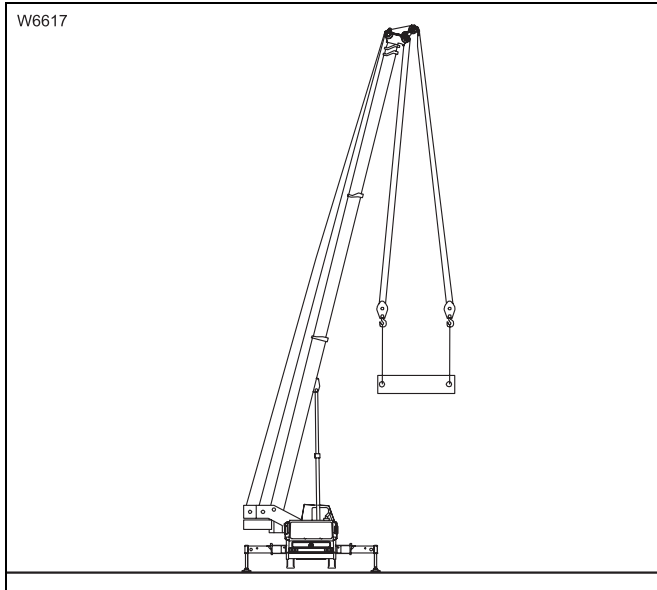

- Now lift the load with the hook block on the main boom until both slinging points are at the same height.

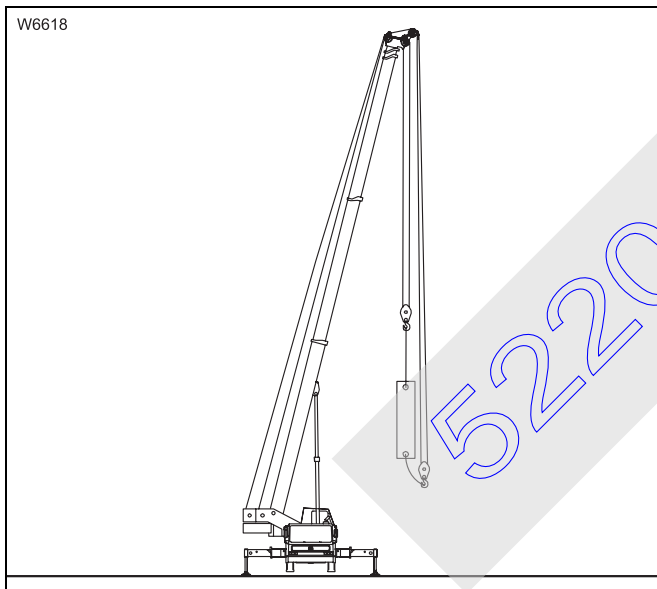

- Slacken the hoist rope on the auxiliary single-sheave boom top until the load is only hanging from the hook block on the main boom.

Turning the load has now been completed.

5.6

Driving with rigged truck crane and rigged auxiliary single-sheave boom top

The procedure, tables with boom positions, and axle loads valid for driving with rigged truck crane also apply to driving with rigged auxiliary single-sheave boom top, ■■■► *Operating instructions GMK 5220 – Part 2 Crane operation – Driving with rigged truck crane.*

- Pay attention to the
 - given safety instructions
 - procedure
 - boom positions
 - maximum axle loads

52203182

6 Heavy load lattice extension

6.1	Identification	6 - 1
6.2	Attaching and securing the heavy load lattice extension	6 - 3
6.2.1	Slings point	6 - 3
6.2.2	Securing the heavy load lattice extension with guide rope	6 - 4
6.3	Installing/removing the heavy load lattice extension	6 - 5
6.3.1	Installing the heavy load lattice extension	6 - 5
6.3.2	Removing the heavy load lattice extension	6 - 7
6.4	Rigging the heavy load lattice extension	6 - 9
6.4.1	Rigging in transport position	6 - 9
6.4.2	Rigging in working position	6 - 11
6.4.3	Setting the angle position of the heavy load lattice extension	6 - 13
6.4.4	Attaching and removing the hoist rope	6 - 15
6.4.5	Lifting limit switch and anemometer	6 - 17
6.4.6	Transportation on a separate vehicle	6 - 19
6.5	Operation with the heavy load lattice extension	6 - 21
6.5.1	Setting the SLI	6 - 22
6.5.2	Raising and setting down the main boom	6 - 24
6.5.3	Telescoping with rigged heavy load lattice extension	6 - 25
6.5.4	Information about the SLI shutdown	6 - 26
6.5.5	Procedure if the permissible wind speed is exceeded	6 - 26
6.5.6	Information about the main boom operation when the heavy load lattice extension is folded/rigged	6 - 27
6.6	Turning loads with the heavy load lattice extension	6 - 29
6.6.1	Prerequisites	6 - 29
6.6.2	Setting the SLI	6 - 30
6.6.3	Turning a load	6 - 32
6.7	Driving with rigged truck crane and rigged heavy load lattice extension	6 - 35

52203182

6 Heavy load lattice extension

6.1 Identification

The heavy load lattice extension is matched to the truck crane with which it is delivered. The heavy load lattice extension belonging to the truck crane has the same serial number as the truck crane.



Risk of accidents during operation with non-modified heavy load lattice extension

Operate the truck crane only with the heavy load lattice extension with the identical serial number.

The SLI is set only for this heavy load lattice extension.

This prevents malfunctions and damage.

If you wish to use the heavy load lattice extension on several GROVE truck cranes, the extension must be adjusted for these cranes and labelled with all of the respective serial numbers.



Risk of accidents if not modified correctly.

The modification of the heavy load lattice extension may only be carried out by **CraneCARE**.

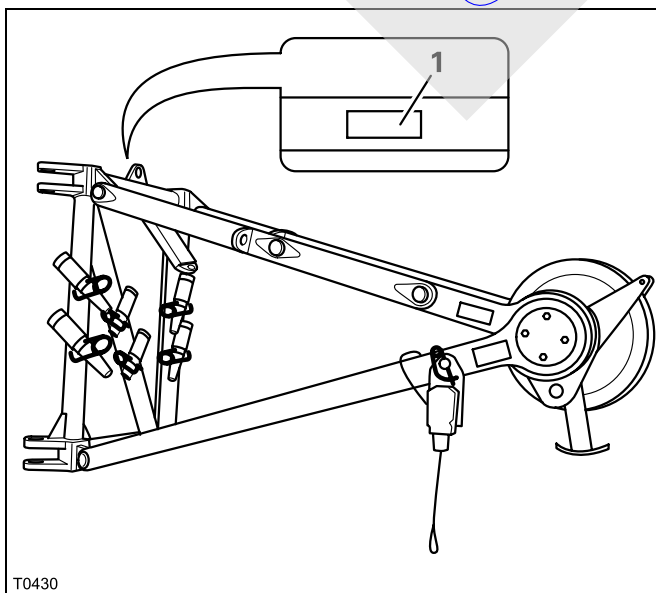

The serial number (1) is on the cross-strut of the heavy load lattice extension.

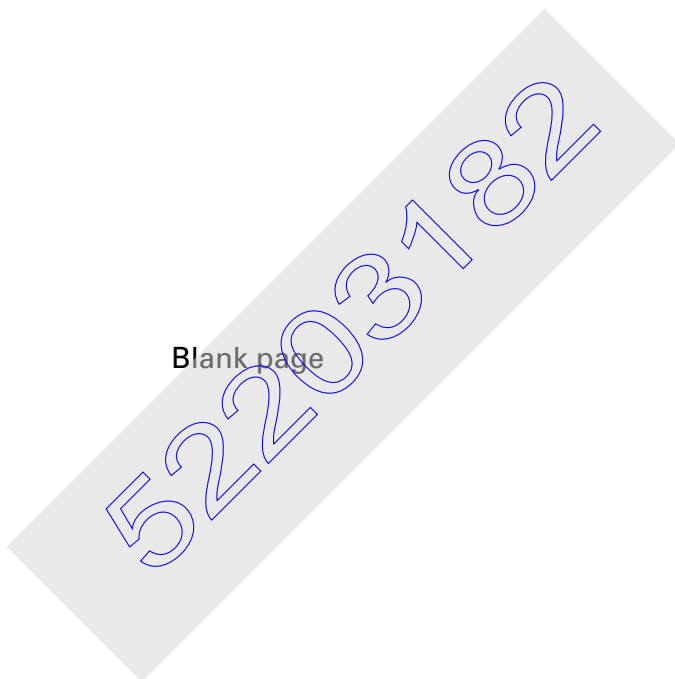

6.2

Attaching and securing the heavy load lattice extension

6.2.1

Slinging point



Risk of accidents due to the heavy load lattice extension falling down

Attach the heavy load lattice extension only as described in this section to ensure that it has the right centre of gravity.

Only use appropriate lifting gear having sufficient lifting capacity;  *Heavy load lattice extension*, p. 2 - 2.

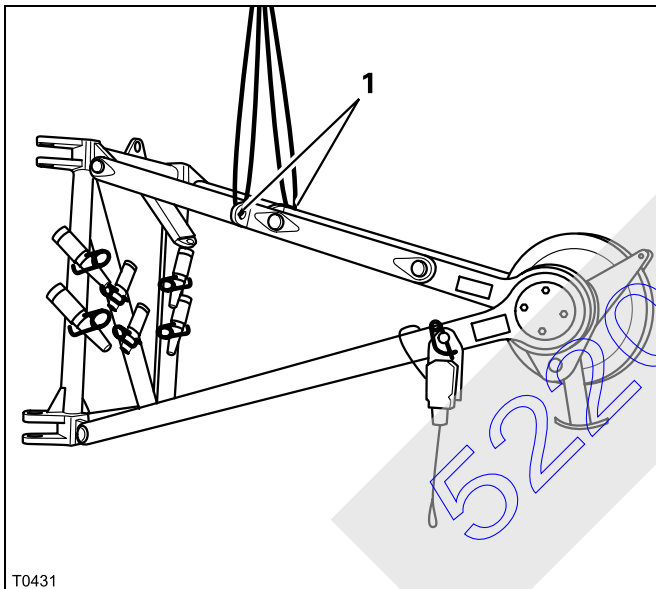

- Attach the heavy load lattice extension at the slinging points (1) at an angle of 0°. Now the heavy load lattice extension hangs in a horizontal position on the auxiliary crane.

T0431

6.2.2

Securing the heavy load lattice extension with guide rope



Risk of accidents due to the heavy load lattice extension swinging of its own accord

Always secure the heavy load lattice extension with a guide rope on the main boom before removing any connections.

This prevents the heavy load lattice extension from swinging around of its own accord and causing injury to you or other persons.



If you happen to be alone, secure the other end of the guide rope on the truck crane (e.g. on the main boom).

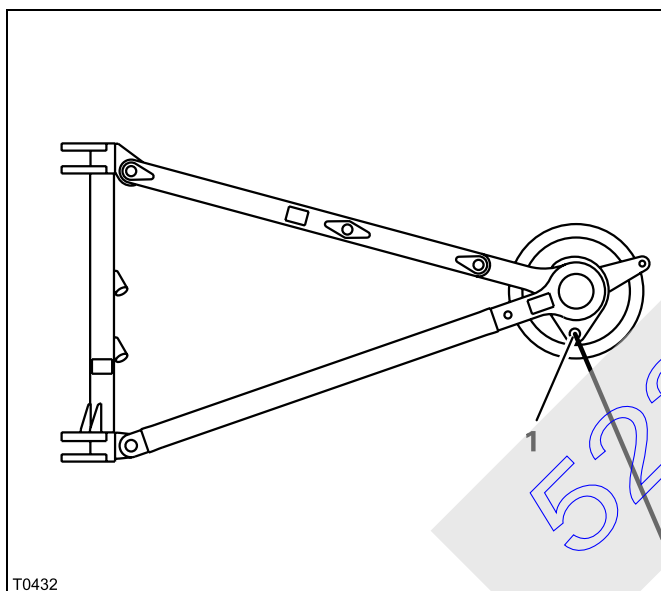

Secure the heavy load lattice extension in the following manner:

- Attach one guide rope to the rope fixed point (1).
- Have a person hold the guide rope taut while you establish or loosen pin connections on the heavy load lattice extension.

6.3

Installing/removing the heavy load lattice extension



Risk of accidents due to the heavy load lattice extension falling down

Only use appropriate lifting gear having sufficient lifting capacity;

▣▣▣▣ *Transport dimensions and weights, p. 2 - 1.*

6.3.1

Installing the heavy load lattice extension



If the heavy load lattice extension is installed, the swing-away lattice extension cannot be rigged in front of the main boom.

Prerequisites:

- The truck crane is on outriggers or the main boom has been placed on the boom rest.
- The required counterweight has been rigged.
- The heavy load lattice extension is at an angle of 0°.
- An auxiliary crane is available.

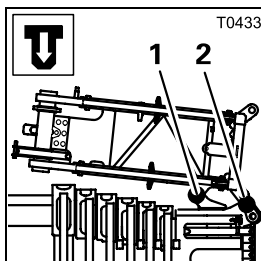

For installation, the heavy load lattice extension is fastened in the holding device (1) with pins (2).

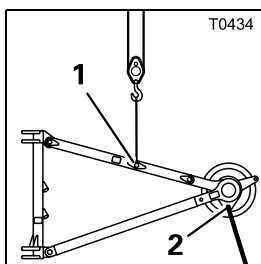

- Attach the heavy load lattice extension at the slinging point (1);
▣▣▣▣ p. 6 - 3.
- Attach the guide rope to the rope attachment point (2); ▣▣▣▣ p. 6 - 4.



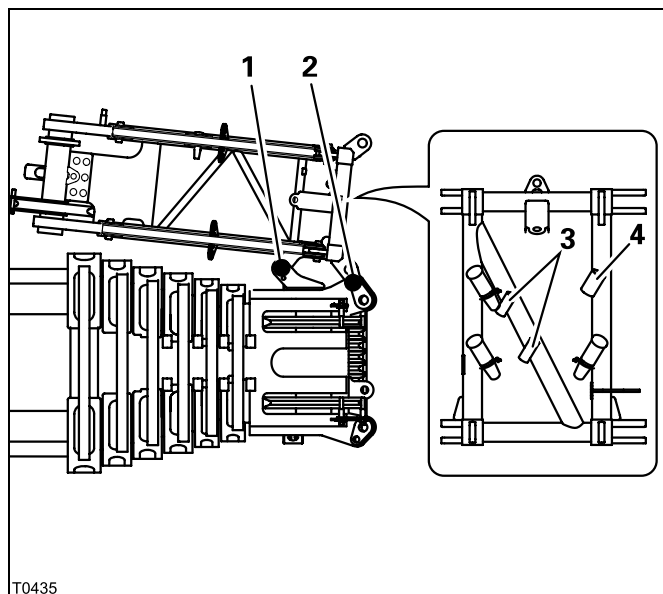

- Hoist the heavy load lattice extension on to the left side of the main boom such that the bearing points (2) line up.
- Take the pins out of the holders (3) and insert the pins into the bearing points (2). Secure them.
- Loosen the lifting gear.
- Swivel the heavy load lattice extension into the main boom until the bearing points (1) are aligned.
- Take the pin out of the holders (4) and insert it into the bearing point (1). Secure it.
- Depending on the application, move the heavy load lattice extension into transport position or working position;
 - ▣▣▣▣▶ *Rigging in transport position*, p. 6 - 9,
 - ▣▣▣▣▶ *Rigging in working position*, p. 6 - 11.
- Remove the guide rope.

52203182

6.3.2

Removing the heavy load lattice extension

Prerequisites:

- The truck crane is on outriggers or the main boom has been placed on the boomsupport.
- The required counterweight has been rigged.
- The heavy load lattice extension is at an angle of 0°.
- The hoist rope is unreeved.
- The lifting limit switch and anemometer are in transport position.
- An auxiliary crane is available.

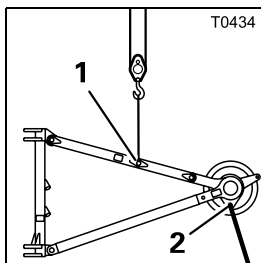

- Attach the heavy load lattice extension at the slinging point (1); p. 6 - 3.
- Attach the guide rope to the rope attachment point (2); p. 6 - 4.
- Make sure that the electrical connections have been separated; *Lifting limit switch and anemometer*, p. 6 - 17.

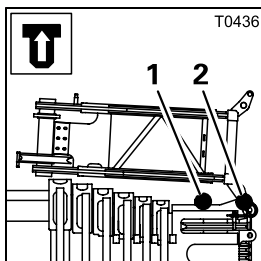

In transport position:

The heavy load lattice extension is folded to the side of the main boom and is fastened with the pins (2) and (1).

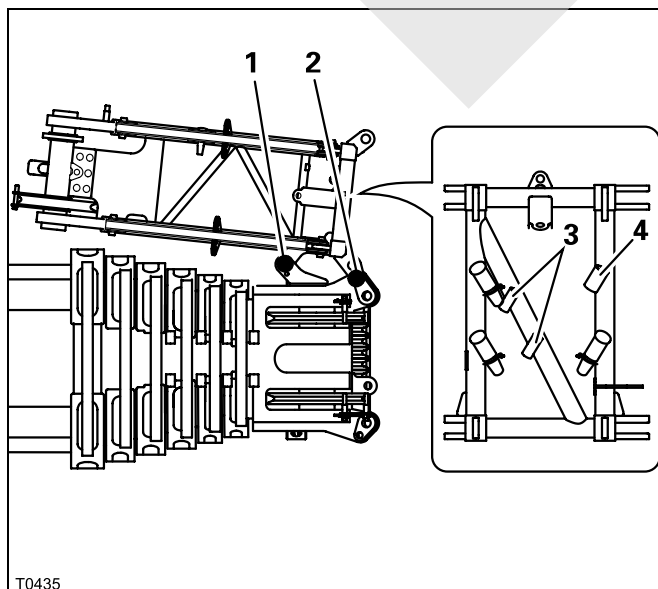

- Take the two pins out of the bearing points (2) and insert them into the holders (3).
- Take the pin out of the bearing point (1) and insert it into the holder (4).
- Secure all the pins in the holders.
- Lift the heavy load lattice extension from the main boom head.



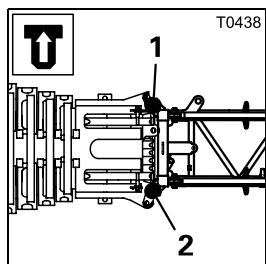

In working position:

The heavy load lattice extension is folded in front of the main boom and is fastened with the pins (1) and (2).

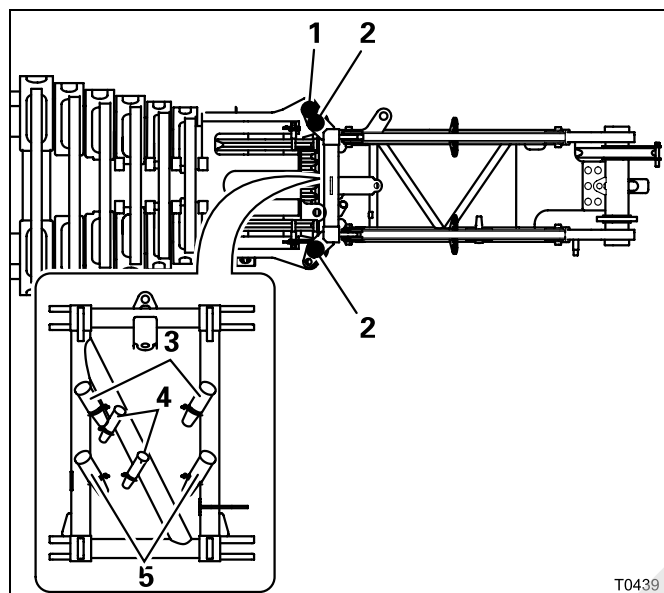

- Take the four pins out of the bearing points (2) and insert them into the holders (3) and (5).
- Take the two pins out of the bearing points (1) and insert them into the holders (4).
- Secure all the pins in the holders.
- Lift the heavy load lattice extension from the main boom head.

52203182

6.4

Rigging the heavy load lattice extension

6.4.1

Rigging in transport position

Prerequisites:

- The truck crane is on outriggers or the main boom has been placed on the boomsupport.
- Heavy load lattice extension in working position.
- Heavy load lattice extension is at an angle of 0°.
- The hoist rope is unreeved.

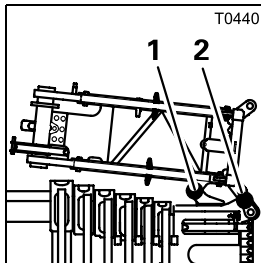

In the transport position, the heavy load lattice extension is folded to the side of the main boom and is fastened with the pins (2) and (1).

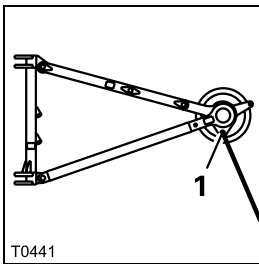

- Attach the guide rope to the rope attachment point (1);  p. 6 - 4.

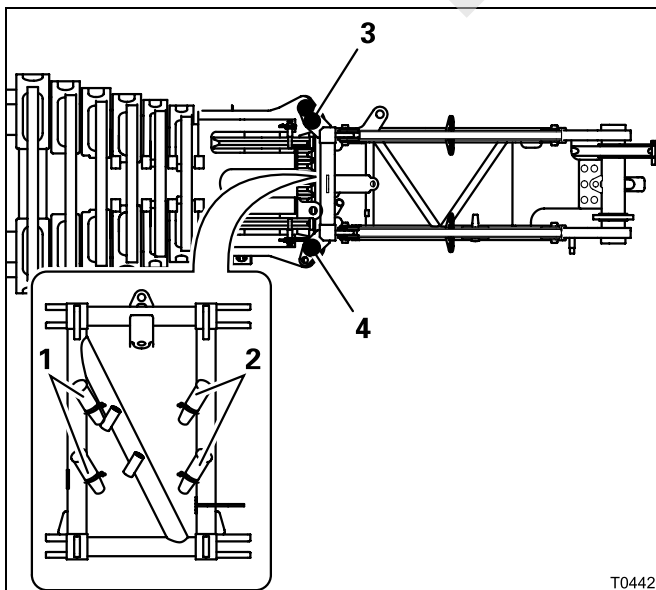

- Remove the pins from the bearing points (3).
- Insert the pins into the holders (2) and secure them.
- Remove the pins from the bearing points (4).
- Insert the pins into the holders (1) and secure them.



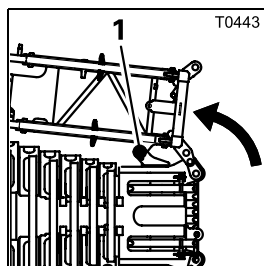

- Swivel the heavy load lattice extension into the main boom until the bearing points (1) are aligned.

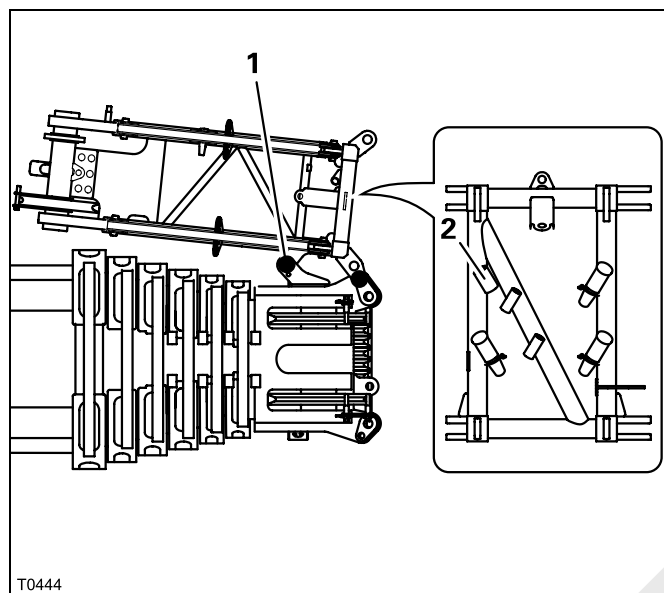

- Withdraw the pin from the holder (2) and insert it into the bearing point (1). Secure the pin.

- Detach the guide rope from the rope attachment point.

The heavy load lattice extension is now in transport position.

52203182

6.4.2

Rigging in working position

Prerequisites:

- The truck crane is on outriggers or the main boom has been placed on the boomsupport.
- Heavy load lattice extension in transport position.
- The required counterweight has been rigged.

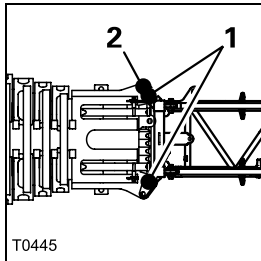

In working position, the heavy load lattice extension is secured with four pins (1) and two pins (2) in front of the main boom head.

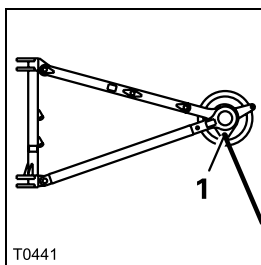

- Attach the guide rope to the rope attachment point (1);  p. 6 - 4.

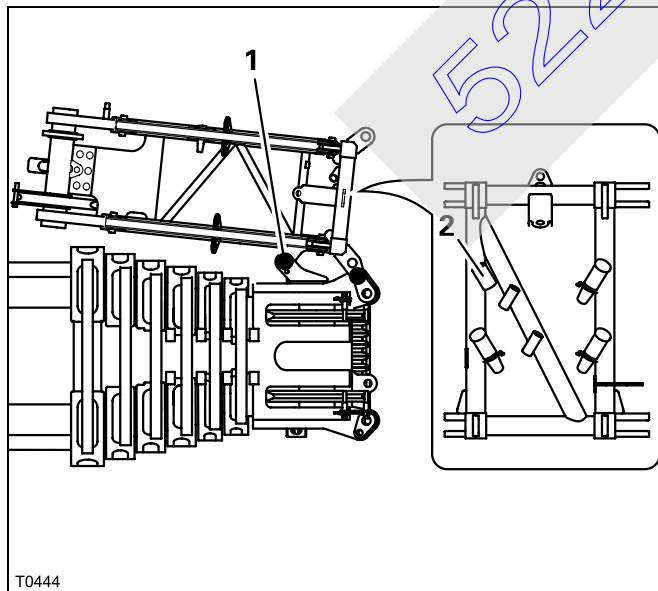

- Withdraw the pin from the bearing point (1) and insert it into the holder (2). Secure it.



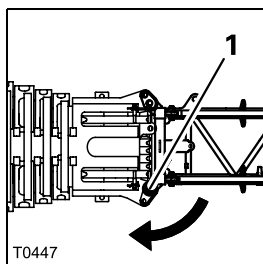

- Swivel the heavy load lattice extension onto the main boom until the bearing point (1) is aligned with the bore hole.

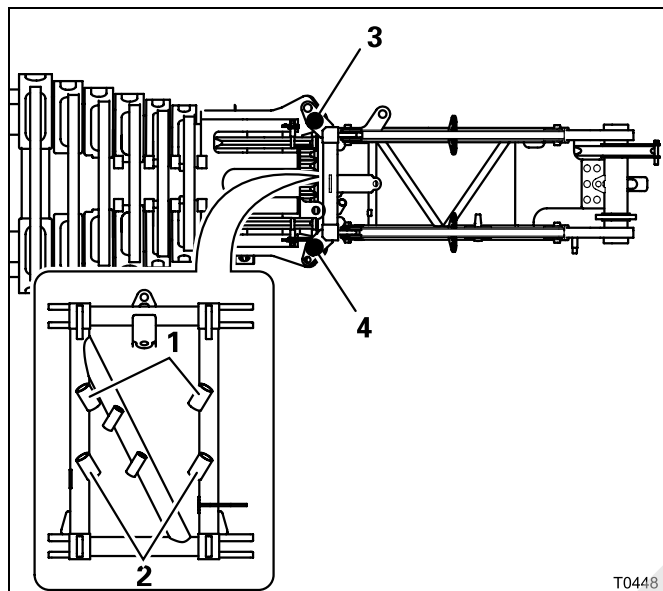

- Take the pins out of the bearing points (1) and insert them into the holders (4). Secure the pins.
- Take the pins out of the bearing points (2) and insert them into the holders (3). Secure the pins.
- Detach the guide rope from the rope attachment point.

The heavy load lattice extension is now in working position.

- Insert the hoist rope; ■■■▶ *Attaching and removing the hoist rope, p. 6 - 15.*
- Reeve the hook block correspondingly.
 - ▶ *Possible reeving methods on the heavy load lattice extension, p. 6 - 16,*
 - ▶ *Operating instructions GMK 5220 – Part 2 Crane operation – Reeving the hoist rope.*

6.4.3 Setting the angle position of the heavy load lattice extension

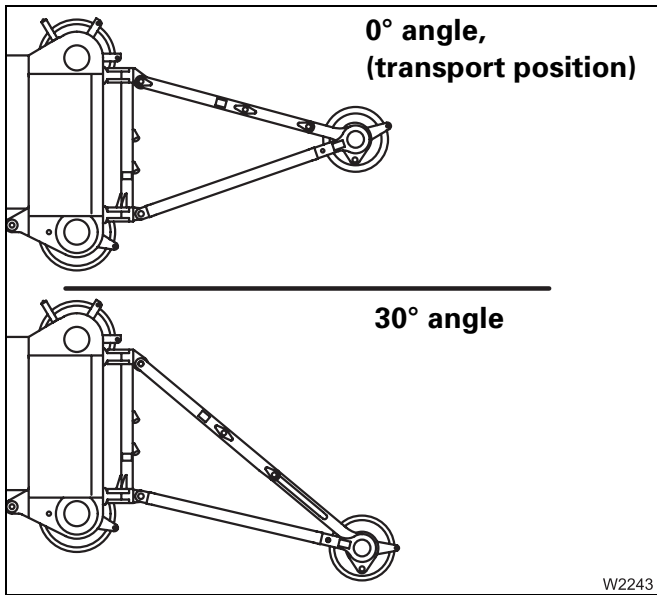

Depending on requirements, the heavy load lattice extension can be operated at two different angles.

Installing/ removing the chain hoist



Only use the chain hoist supplied to set the angle.

Risk of accidents from uncontrolled movements

When removing the chain hoist, the heavy load lattice extension must be set at an angle of 0° or 30°. This prevents the heavy load lattice extension from folding down in an uncontrolled manner and injuring or even killing you or others standing nearby.

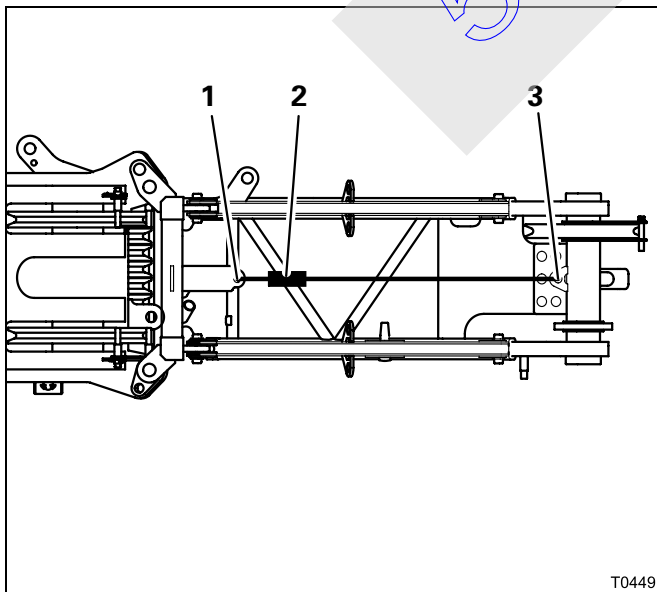

Installation

- Attach the chain hoist (2) at the slinging points (1) and (3).

Removal

The heavy load lattice extension is set at a 0° or 30° angle.

- Unload the chain hoist (2).
- Remove the chain hoist at the slinging points (1) and (3).



Setting the angle position

- Hook in the chain hoist,  *Installing/removing the chain hoist*, p. 6 - 13.

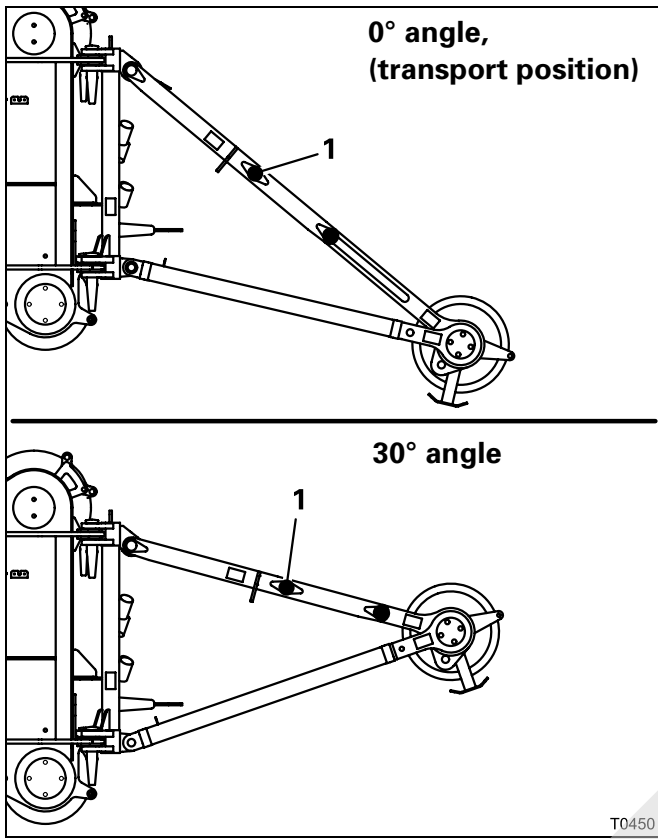

- Lift the heavy load lattice extension with the chain hoist until the pin (1) is relieved.
- Release the retaining pin and remove the pin (1) from the bearing point.
- Hoist the heavy load lattice extension or lower it.

For 0° angle:

Hoist the heavy load lattice extension to its full extent.

For 30° angle:

Lower the heavy load lattice extension as far as it will go.

- Plug the pin (1) back into the bearing point and secure it with the retaining pin.
- Detach the chain hoist.



Risk of uncontrolled movements

When setting the 30° angle, lower the heavy load lattice extension always as far as it will go and insert the pin back into the bearing point. This way, you can prevent the heavy load lattice extension from being in a non-permissible position without a fall-back guard.

6.4.4

Attaching and removing the hoist rope



Risk of accidents due to falling parts

Always secure the rope holding rollers and rods with retaining pins. This prevents elements from coming loose, falling down and injuring people.

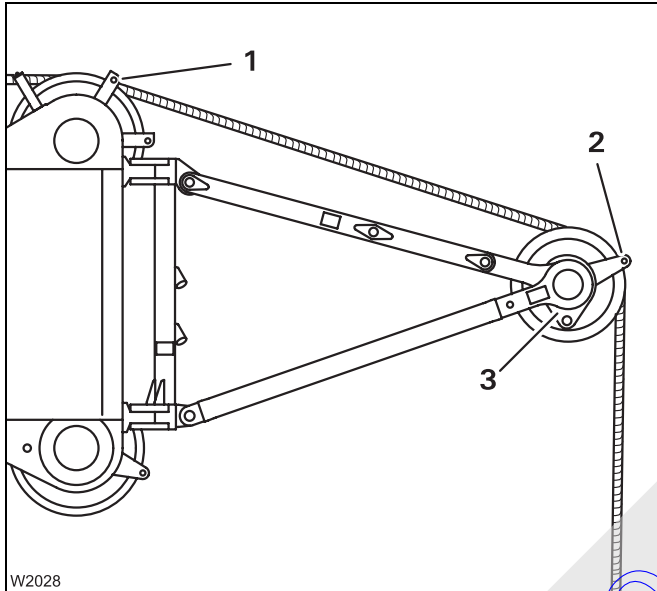

- Remove the rope holding rollers (1) and (1) from the main boom head and from the heavy load lattice extension.
- When reeving, guide the hoist rope over the left head sheave of the main boom.
- Plug in the rope holding rods into the bores and secure them with retaining pins.

The hoist rope can be reeved one or two-fall;
▣▣▣▣ p. 6 - 16.

For double reeving, the hoist rope is attached to the rope attachment point (3).

Proceed in reverse order to remove the hoist rope.



Possible reeving methods on the heavy load lattice extension

The hoist rope can be reeved once or twice.

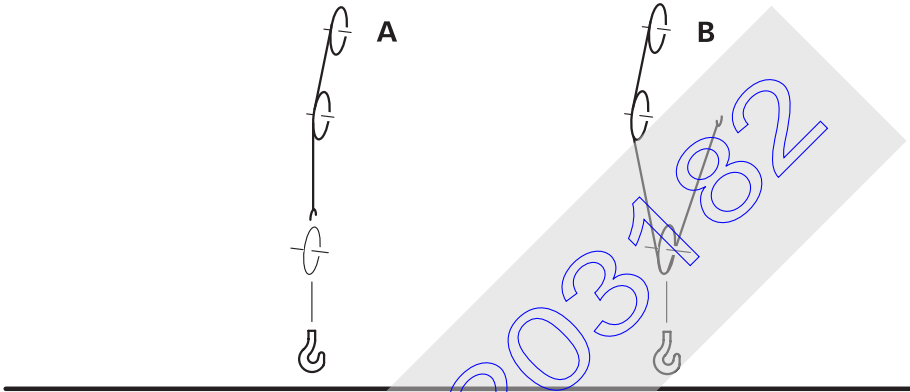
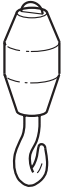
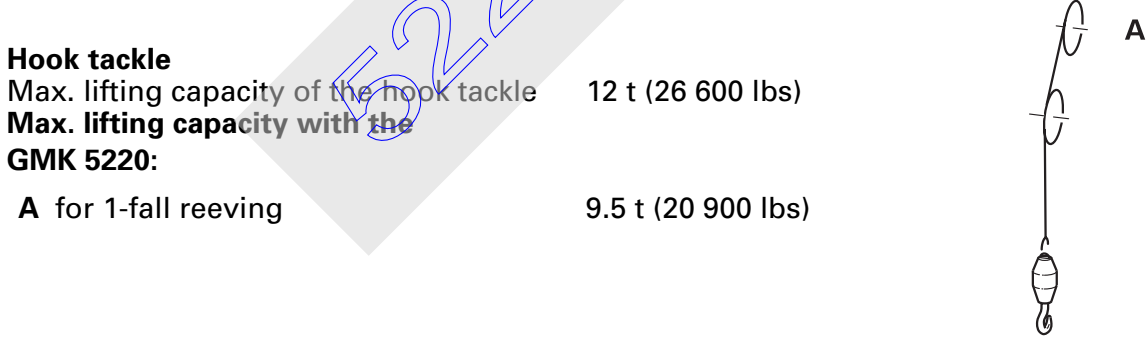
	<p>1-sheave hook block Max. lifting capacity of the hook block 32 t (70 500 lbs) Max. lifting capacity with the GMK 5220: A for 1-fall reeving 9.5 t (20 900 lbs) B for 2-fall reeving 19.0 t (41 800 lbs)</p>
	
	<p>Hook tackle Max. lifting capacity of the hook tackle 12 t (26 600 lbs) Max. lifting capacity with the GMK 5220: A for 1-fall reeving 9.5 t (20 900 lbs)</p>
	

W6601

Reeving the hoist rope on the hook block;  *Operating instructions GMK 5220 – Part 2, Crane operation – Reeving hoist rope.*

6.4.5

Lifting limit switch and anemometer

Lifting limit switch For operation

For each reeved hoist rope, a lifting limit switch must be installed. Information on this can be found in the *Operating instructions GMK 5220, Part 2 Crane operation – Rigging work – Installing/removing lifting limit switch.*

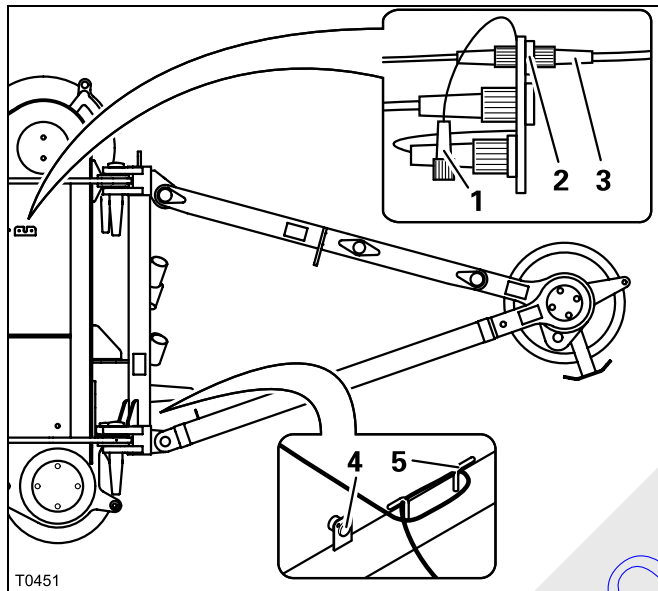

On the right side

- Remove the bridging plug from the socket (2).
- Unwind the cable from the clamp (5).
- Remove the plug (3) from the dummy socket (4) and plug it into the socket (2).
- Wind up the connecting cable of the plug (3) far enough on the clamp (5) so that it does not hang down.
- Install the lifting limit switch weight and lay it around the hoist rope; ► *Operating instructions GMK 5220.*

On the left side

If, additionally, a hook block is reeved on the main boom, connect the second lifting limit switch to the socket on the left side of the main boom head; ► *Operating instructions GMK 5220.*

If no hook block is reeved on the main boom, the bridging plug must be plugged into the socket that is not used; ► *Operating instructions GMK 5220.*



For removal

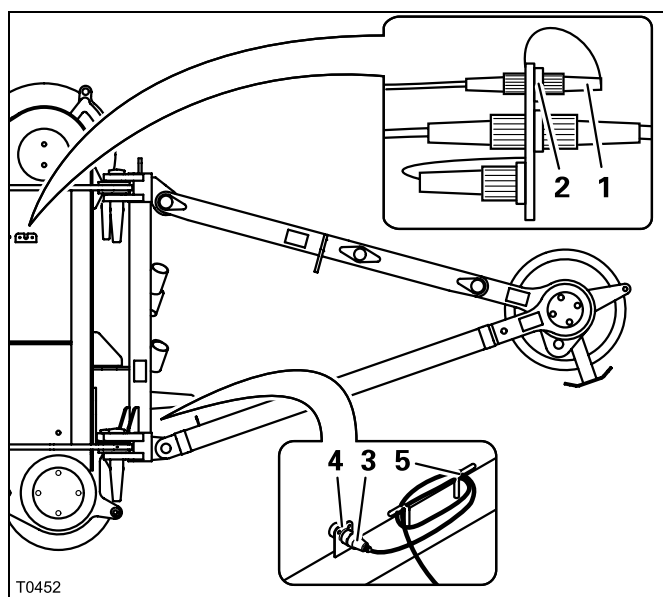

On the left side

- Remove the plug (3) from the socket (2) and plug it into the dummy socket (4).
- Insert the bridging plug (1) into the socket (2).
- Wind the connecting cable of the plug (3) onto the holder (5).

On the right side

If no hook block is reeved on the main boom, the bridging plug must be plugged into the socket that is not used;  *Operating instructions GMK 5220.*

Anemometer

Installation and removal

You must install the anemometer for operation with the auxiliary single-sheave boom top.

You must remove the anemometer for driving on-road.

It is installed and removed in the same way as for operation with the main boom;  *Operating instructions GMK 5220.*



Risk of damage to the anemometer

Remove the anemometer for on-road driving.

This prevents the anemometer from being damaged by wind (e.g. by suction currents caused by oncoming traffic in tunnels).

6.4.6

Transportation on a separate vehicle

Information on whether the heavy load lattice extension must be removed for driving with a maximum axle load of 12 t can be found in the Operating instructions GMK 5220, *Part 1 Crane operation – Driving modes*.

If the heavy load lattice extension must be removed:



Risk of injury

Attach the lattice extension only at the designated points and use only lifting gear with sufficient load lifting capacity.

This prevents the heavy load lattice extension from falling and injuring people during loading;

▣▣▣▣▶ *Slinging point*, p. 6 - 3,

▣▣▣▣▶ *Transport dimensions and weights*, p. 2 - 1.

- For transport, set the lattice extension down so as not to damage it.
- Always secure the heavy load lattice extension on the separate vehicle additionally with belts to prevent slipping and overturning.

52203182

Blank page

52203182

6.5

Operation with the heavy load lattice extension



During operation with the lattice extension, the speed for all power units is limited to 70%.



Risk of accidents due to falling chain hoist

Always detach the chain hoist before operation with the heavy load lattice extension.

This prevents the chain hoist from falling and injuring persons or damaging the truck crane.

The hoisting, lowering, slewing, derricking and telescoping movements are carried out in the same way as when operating with the main boom.

This section only contains information that you will need for a rigged or installed heavy load lattice extension:

▣▣▣▣ *Setting the SLI, p. 6 - 22,*

▣▣▣▣ *Raising and setting down the main boom, p. 6 - 24,*

▣▣▣▣ *Telescoping with rigged heavy load lattice extension, p. 6 - 25,*

▣▣▣▣ *Information about the SLI shutdown, p. 6 - 26,*

▣▣▣▣ *Procedure if the permissible wind speed is exceeded, p. 6 - 26,*

▣▣▣▣ *Information about the main boom operation when the heavy load lattice extension is folded/rigged, p. 6 - 27,*

▣▣▣▣ *Information about the SLI shutdown, p. 6 - 26.*

6.5.1 Setting the SLI



If a hook block is reeved on the main boom during operation with the heavy load lattice extension, the loads given in the *Lifting capacity tables* decrease and the SLI switches off earlier.

The values which must be deducted from the load capacities depend on the length of the lattice extension and the weight of the hook block. You will find a table with the values in the *Lifting capacity tables* in the *Section Remarks about working with the heavy load lattice extension*.

For the heavy load lattice extension, the length and the set angle of the heavy load lattice extension are also entered and displayed.

- Enter the current reeving at the SLI.
- Enter the current rigging mode on the SLI, either using the corresponding SLI code according to the *lifting capacity table* or using the individual components.
- Check whether the current rigging mode of the truck crane corresponds to the displayed rigging mode.

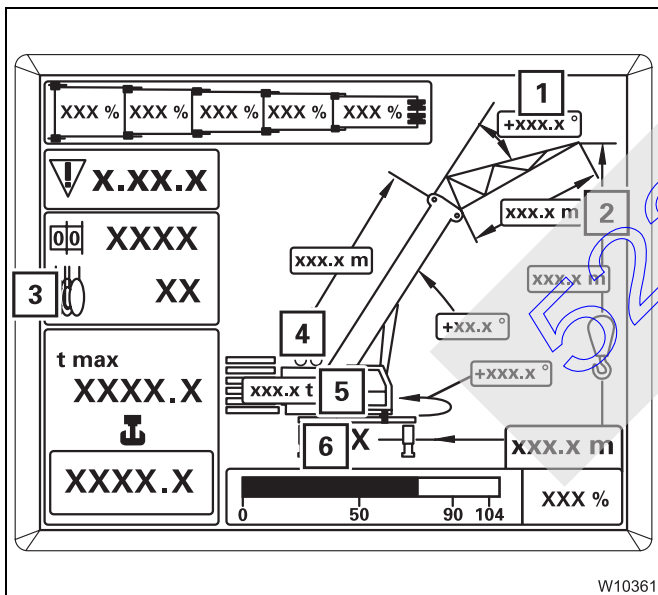

- Check:
 - 1 The set angle position of the heavy load lattice extension.
 - 2 The rigged length of the heavy load lattice extension.
 - 3 The number of reeved rope lines
 - 4 The hoist which is switched on
 - 5 The rigged counterweight
 - 6 The rigged outrigger span

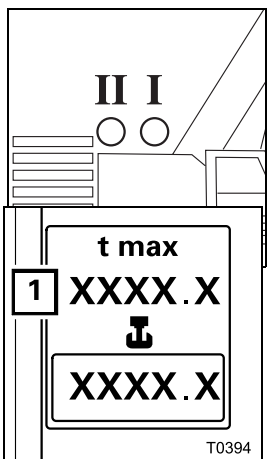

Hoist display

The light which goes on must always be for the hoist with which the load is to be lifted.

Light I: Must go on if the load is to be raised with the main hoist.

Light II: Must go on if the load is to be raised with the auxiliary hoist.

If the telescopic sections are mechanically locked, the SLI will now release

the load according to the *Lifting capacity table* and the *Maximum load display (1)* shows the corresponding value.

Only the value for the empty hook curve is released and shown when the telescopic sections are unlocked.

52203182

6.5.2

Raising and setting down the main boom

The following prerequisites must be fulfilled when raising and setting down the main boom with rigged heavy load lattice extension:

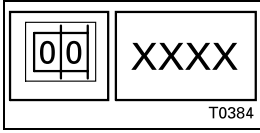

- The current rigging mode with the rigged heavy load lattice extension is entered on the SLI, and the corresponding SLI code is displayed as per the *Lifting capacity table*;  *Setting the SLI*, p. 6 - 22.

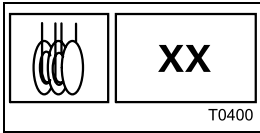

- The current reeving type on the heavy load lattice extension is entered for the hoisting gear whose hoist rope is reeved on the heavy load lattice extension.

- Apart from the hook block, there is no load on the lattice extension.

- The main boom is fully retracted.

The SLI will only release the main boom for raising and setting it down when the main boom is completely retracted.

When all of the above prerequisites have been fulfilled, the SLI will automatically switch to the rigging tables and derricking can then be done in the angle range underneath the working range of approx. 60°.

Raising

- Derrick in the main boom to raise it.

Setting down

- Derrick out the main boom to set it down.

6.5.3

Telescoping with rigged heavy load lattice extension

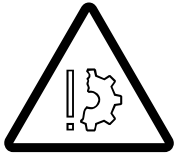

Risk of overloading the main boom

If you are telescoping the main boom with the rigged heavy load lattice extension, you may not simultaneously slew the superstructure.

This prevents the main boom being subjected to additional side forces and increased vibration and becoming overloaded.

The telescoping of the main boom with a rigged heavy load lattice extension is monitored by the SLI. Telescoping will only be enabled if the main boom is derricked to a certain angle and a maximum permissible load is not exceeded.

The required angle (between 40° and 80°) depends on:

- The angle of the heavy load lattice extension
- The extended length of the main boom
- The rigged counterweight
- The rigged outrigger span

You will find the required main boom angle and maximum permissible load (weight of the hook block) in the *Lifting capacity tables*, in the Chapter *Rigging tables – Heavy load lattice extension*.

If the main boom angle is too small for telescoping with the heavy load lattice extension, the SLI displays a appropriate error message.

The telescoping mechanism is operated in the same way as the main boom;
▣▣▣▣▶ *Operating instructions GMK 5220 – Telescoping mechanism.*

6.5.4 Information about the SLI shutdown

The operation with the heavy load lattice extension is monitored by the SLI.

SLI shutdowns can occur during lattice extension operation for the same reasons as with main boom operation;  *Operating instructions GMK 5220, Part 2 – Crane operation.*

6.5.5 Procedure if the permissible wind speed is exceeded

Strong winds can result in the truck crane becoming overloaded. Therefore, closely observe the instructions in the section *Effect of wind on crane operation*,  *GMK 5220 Operating instructions, Part 2 – Crane operation.*

If the maximum permissible wind speed according to the <i>Lifting capacity table</i> is exceeded during the main boom operation, proceed as follows:	
At a wind speed of up to 20 m/s	At a wind speed of over 20 m/s
<ul style="list-style-type: none">• Set down the load.• Slew the superstructure so that the main boom offers as little wind resistance as possible.	<ul style="list-style-type: none">• Set down the load.• Fully retract the main boom.

6.5.6

Information about the main boom operation when the heavy load lattice extension is folded/rigged

This section applies for installed heavy load lattice extension regardless of whether it is in the working position or rigging position.



Risk of overturning with impermissible rigging mode

Main boom operation with an installed heavy load lattice extension is only permissible in rigging modes that are also permissible for the rigged heavy load lattice extension (outrigger span, counterweight, slewing range). If you set up rigging modes that are only valid for main boom operation without a rigged heavy load lattice extension (e.g. *Free on wheels* working position), there is the danger of the truck crane overturning during operation.

For main boom operation with an installed heavy load lattice extension, you must enter the current rigging mode for the main boom without a heavy load lattice extension on the SLI.

In this case, the values given in the corresponding *Lifting capacity tables* for the lifting capacities decrease.

Reduction of the lifting capacity

The *Maximum load* display (1) does **not** show the reduced values.

The SLI also takes into account the load moment affected by the rigged heavy load lattice extension and switches off earlier.

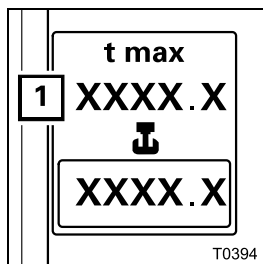

In the *Lifting capacity tables* you will find tables with values for the reduction of the lifting capacities in the Section *Remarks about working with the heavy load lattice extension*. The given values for reduction are only maximum values for certain rigging modes (angle and length of main boom and lattice extension).

The SLI, however, takes into account the value for the currently rigged heavy load lattice extension, adds the weight of the raised load and displays the sum on the *Current load* display (1).

The displayed value could deviate from the value that was previously calculated during the operations planning.

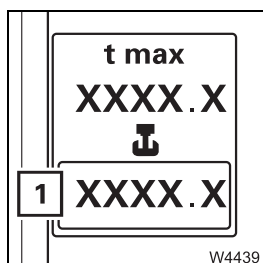

If this is the case, the SLI is not defective. Do not override the SLI. Even if the displayed value is higher than the calculated value.



Risk of accidents with overridden SLI!

Do not under any circumstances override the SLI.

If the SLI is overridden, the crane operations will not be monitored and the truck crane will overturn if you leave the permissible working range.

52203182

6.6

Turning loads with the heavy load lattice extension

Two-hook operation is required for turning loads.

The only type of two-hook operation technically possible and protected by the SLI is described in this chapter using the turning of loads as an example.



Risk of accidents due to overloading

Lifting a load with two hooks is permitted only if the following instructions and illustrations are observed.

If these instructions are disregarded, accidents can occur due to individual parts of the truck crane being overloaded. The SLI then no longer provides protection.



Risk of accidents due to overloading

The load must always be lifted completely with the weakest part (heavy load lattice extension) first.



For information on the position and function of the operating instruments required;  *Operating instructions GMK 5220 – Part 2 Crane operation – Operating elements.*

6.6.1

Prerequisites

The following description requires that:

- The main hoist rope is reeved on the main boom
- The auxiliary hoist rope on the heavy load lattice extension is reeved
- The lifting limit switches for both hoists are connected



Risk of accidents due to overloading

The reeving on the main boom must be equal to or greater than that on the heavy load lattice extension.

The main hoist rope and the main hoist will become overloaded if this condition is not met.

6.6.2

Setting the SLI

You must enter the following settings on the SLI for two-hook operation:

- Enter the current reeving for the main and auxiliary hoist.
The values are stored and called up directly when switching hoists.
- Switch on operation with both hoists in such a way that the digit for the auxiliary hoist lights up on the *Hoists* indicator lamp.

Entering a reeving

You can enter the reeving for both hoists at any time, independent of which hoist is switched on.

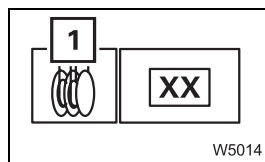

When the *Enter reeving* symbol (1) is shown without digits on the *Reeving* display, you must switch on input mode first:

- Press the button next to the symbol (1) once.

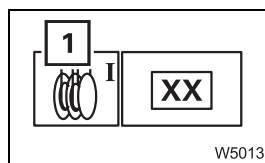

The symbol (1) will be highlighted in green and input mode is enabled. A digit also now appears beside the symbol, e.g. **I**.

This digit shows which hoist the displayed reeving applies to:

- Digit **I**: Main hoist
Digit **II**: Auxiliary hoist

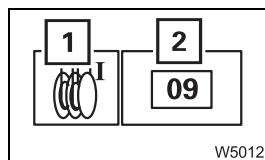

- In the *Reeving* display (2), enter the current number of runs of the reeved hoist rope for the hoist shown (↑ ↓), e.g. **09**, for the main hoist.

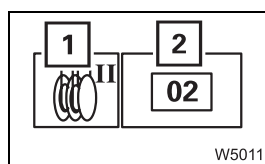

- Press the button next to the symbol *Enter reeving* (1) repeatedly until the digit for the other hoist is shown (e.g. **II** for the auxiliary hoist).
- In the *Reeving* display (2), enter the current number of runs of the reeved hoist rope for this hoist (↑ ↓), e.g. **02** for the auxiliary hoist.

Now the reevings have been entered for both hoists.

Setting the SLI to the auxiliary hoist

The SLI always takes into account the reeving entered for the hoist which is displayed at the *Hoists* indicator lamps. For turning loads, the SLI must take the auxiliary hoist and its reeving into account and both hoists must be switched on. To access this SLI setting, proceed as follows:

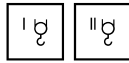

- Switch off both hoists.
To do so, press the bottom part of both rocker buttons *Main hoist on/off* and *Auxiliary hoist on/off* once.
The indicator lamps in the rocker buttons are dimly lit.



- Switch on the auxiliary hoist.
To do so, press the bottom part of the *Auxiliary hoist on/off* rocker button once. The indicator lamp in the rocker button lights up brightly.

At the *Hoists* indicator lamps, lamp II for the auxiliary hoist now lights up.

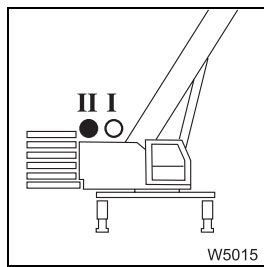

- Now switch on the main hoist.
To do so, press the bottom part of the *Main hoist on/off* rocker button once. The indicator lamp in the rocker button lights up brightly.

At the *Hoists* indicator lamps, lamp I for the main hoist now flashes additionally.

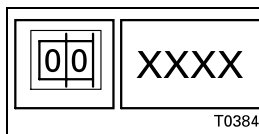
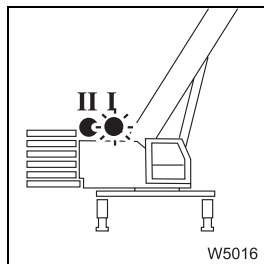

- On the SLI, select the current rigging mode with the rigged lattice extension or enter the appropriate SLI code according to the *lifting capacity table*.

The SLI is now set for two-hook operation. It now takes into account:

- The reeving for the auxiliary hoist
- The lifting capacity tables for the heavy load lattice extension.



In two-hook operation, the load measurement is taken using the pressure in the derricking cylinder. The loads detailed in the *Lifting capacity table* then decrease by the weight of both reeved hook blocks.

6.6.3

Turning a load

Carry out the load turning only as it is described in this section.

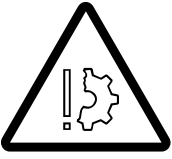

Risk of accidents due to overloading

Keep the acceleration forces as low as possible during two-hook operation. For this reason, move the load at the lowest possible speed.



As soon as the load is on two hooks, there will be slight differences in the *Current load* display. However, these deviations are still on the safe side as regards an SLI shutdown.



During the entire lifting operation, the rigging mode with the heavy load lattice extension must be entered on the SLI and displayed.

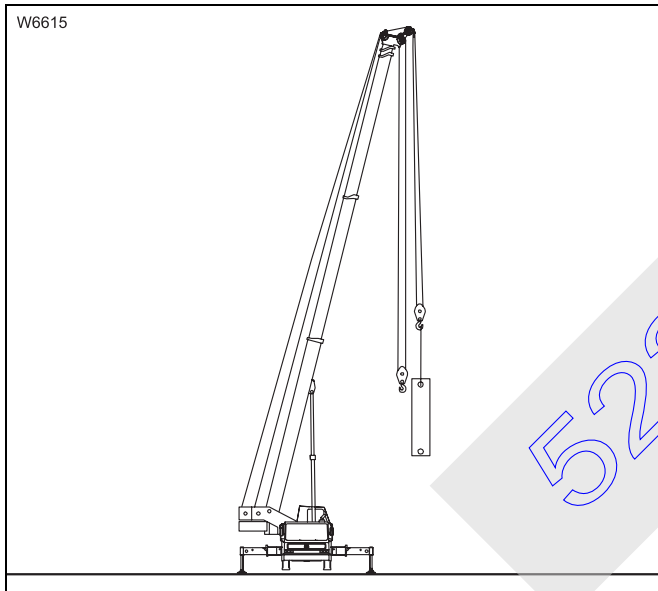

- First, only sling the load to the hook block of the heavy load lattice extension (rope of the auxiliary hoist).
- Lift the load completely off the ground with the heavy load lattice extension.

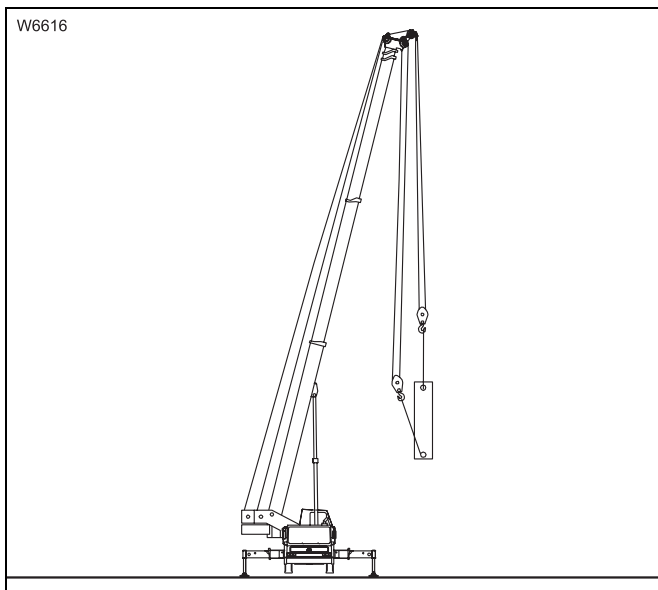

- Only now should you attach the load to the hook block of the main boom as well (main hoist rope).

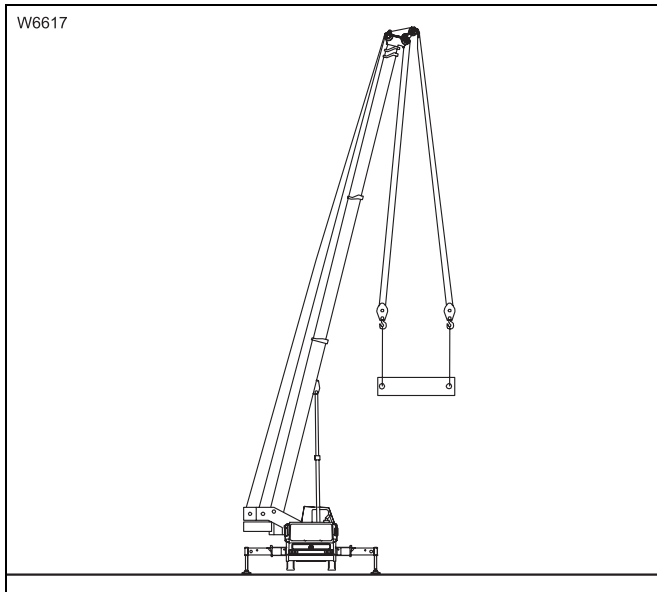

- Now lift the load with the hook block on the main boom until both slinging points are at the same height.

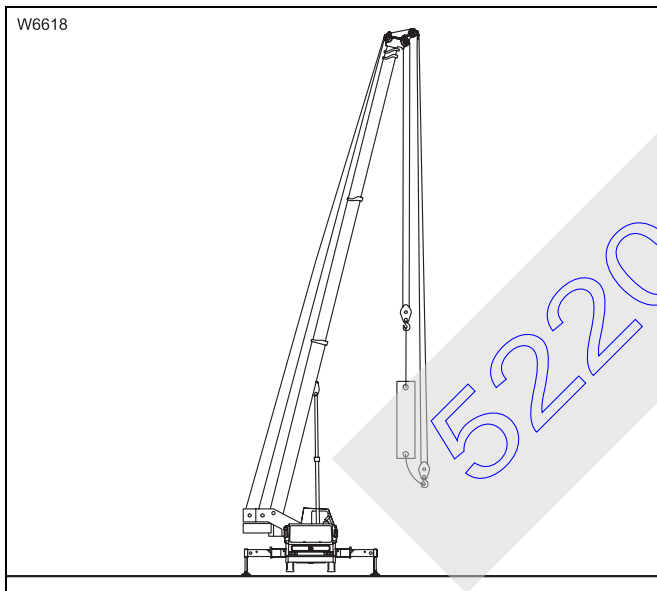

- Slacken the hoist rope on the heavy load lattice extension until the load is only hanging from the hook block on the main boom.
- Turning the load has now been completed.

Blank page

52203182

6.7

Driving with rigged truck crane and rigged heavy load lattice extension

The procedure, tables with boom positions, and axle loads valid for driving with rigged truck crane also apply to driving with rigged heavy load lattice extension,  *Operating instructions GMK 5220 – Part 2 Crane operation – Driving with rigged truck crane.*

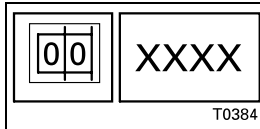

- Enter SLI code as per the *Lifting capacity table* for the actual rigging mode of the truck crane with the rigged heavy load lattice extension.
- Pay attention to the:
 - Specified safety instructions
 - Procedure
 - Boom positions
 - Maximum axle loads

52203182

Blank page

52203182

7 Index

52203182

52203182

7

Index

The index has the following structure:

The names of parts or modules you are searching for are listed in alphabetical order on the left. The following are indented under these terms:

- Operations (e.g. Positioning/removing the hoist rope) or
- Subcategories (e.g. Transport) or
- Subcategories related to operations (e.g. Swivel lattice extension).



The first search word is always a noun which is followed by an operation or a subcategory.

52203182

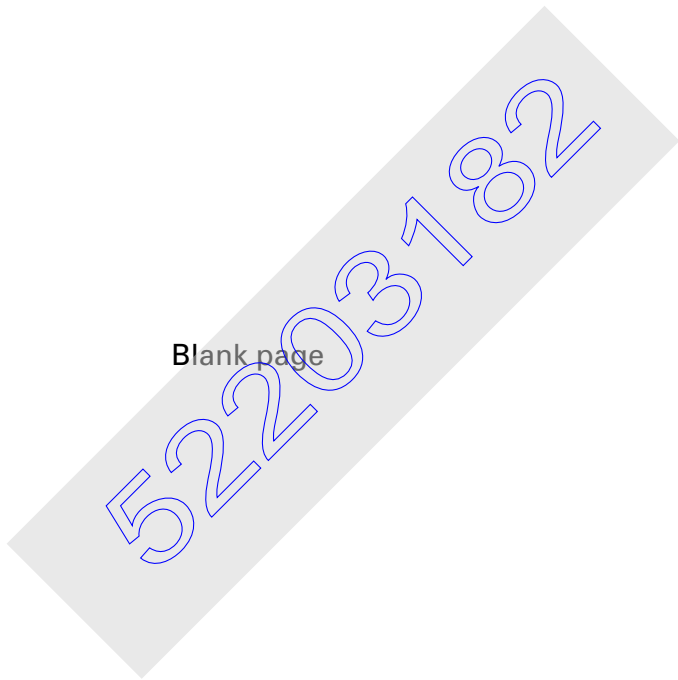

A	Auxiliary single-sheave boom top	
	driving with rigged auxiliary single-sheave boom top	5 - 18
	identification	5 - 1
	installing	5 - 3
	removing	5 - 4
	rigging	
	in transport position	5 - 5
	in working position	5 - 6
	positioning/removing the hoist rope	5 - 7
	possible reeving methods	5 - 7
	Setting the SLI	5 - 8
	transport dimensions and weights	2 - 2
	turning loads	5 - 13
	Axle loads	
	for driving with rigged boom extension	4 - 34
	when driving with rigged auxiliary single-sheave boom top	5 - 18
	when driving with rigged swing-away lattice extension	3 - 113
B	Boom extension	4 - 1
	assembly of boom extensions	4 - 3
	CHECKLIST	
	rigging the 29 m/37 m boom extension	4 - 5
	unrigging the 26 m/32 m boom extension	4 - 9
	driving with rigged boom extension	4 - 32
	axle loads and boom positions	4 - 34
	driving the rigged crane	4 - 37
	identification	4 - 1
	maintenance work	4 - 37
	rigging	
	possible reeving methods	4 - 28
	rigging work	
	establishing/disconnecting the hydraulic connection	4 - 18
	establishing/disconnecting the electrical connection	4 - 22
	installing/dismantling section 3 and section 4	4 - 14
	installing/removing the lattice extension	4 - 16
	positioning/removing the hoist rope	4 - 27
	unfolding/folding the deflection sheave	4 - 26
	slinging points	4 - 2
E	Electrical system	
	on the boom extension	4 - 22
	on the swing-away lattice extension	3 - 74
H	Heavy load lattice extension	
	driving with rigged heavy load lattice extension	6 - 35
	identification	6 - 1

installing	6 - 5
operation	
information about the SLI shutdown	6 - 26
main boom operation when the heavy load lattice extension is folded/rigged	6 - 27
procedure if permissible wind speed is exceeded	6 - 26
telescoping with rigged heavy load lattice extension	6 - 25
possible reeving methods	6 - 16
removing	6 - 7
rigging	
in transport position	6 - 9
in working position	6 - 11
installing/removing the lifting limit switch and anemometer	6 - 17
positioning/removing the hoist rope	6 - 15
setting the angle position	6 - 14
installing/removing the chain hoist	6 - 13
slinging point	6 - 3
transport dimensions and weights	2 - 2
transportation on a separate vehicle	6 - 19
turning loads	6 - 29
with a guide rope	6 - 4
Hoist rope	
possible reeving methods on the auxiliary single-sheave boom top	5 - 7
possible reeving methods on the boom extension	4 - 28
possible reeving methods on the heavy load lattice extension	6 - 16
possible reeving methods on the swing-away lattice extension	3 - 81
Hydraulic system	
on the boom extension	4 - 18
on the lattice extension	3 - 43
I	
Identification	
of the boom extension	4 - 1
of the swing-away lattice extension	3 - 7
the auxiliary single-sheave boom top	5 - 1
the heavy load lattice extension	6 - 1
L	
Lattice extension	
additional operating and display elements	3 - 1
in the crane cab	3 - 1
on the hand-held control	3 - 5
on the lattice extension	3 - 6
centres of gravity	3 - 10
CHECKLIST	
installing the 12/21 m swing-away lattice extension	3 - 12
removing the 12/21 m swing-away lattice extension	3 - 14
rigging the 12/21 m swing-away lattice extension	3 - 19
unrigging the 12/21 m swing-away lattice extension	3 - 25
composition of the swing-away lattice extension	3 - 9

derricking the lattice extension	3 - 91
driving with rigged lattice extension	3 - 111
boom positions and axle loads	3 - 113
driving route	3 - 112
driving the rigged crane	3 - 116
finding and eliminating malfunctions	3 - 121
identification	3 - 7
maintenance work	
maintenance work M1	3 - 124
maintenance work M12	3 - 125
modules in need of protection during cleaning work	3 - 123
operation	3 - 95
derricking the lattice extension	3 - 93
information about the SLI shutdown	3 - 100
main boom operation when the lattice extension is folded/rigged	3 - 102
procedure if the permissible wind speed is exceeded	3 - 101
raising and setting down the main boom with rigged lattice extension	3 - 98
telescoping with rigged lattice extension	3 - 99
overview of the required rigging work	3 - 11
rigging work	
air traffic control light	
installing/removing	3 - 89
checking the transport condition	3 - 33
connecting/disconnecting the slewing connection	3 - 58
connections with folded lattice extension	
in the front area	3 - 46
in the middle area	3 - 51
in the rear area	3 - 53
derricking the lattice extension	3 - 91
establishing/disconnecting the electrical connection	3 - 74
establishing/disconnecting the hydraulic connection	3 - 43
establishing/releasing connections on the lattice extension	3 - 69
folding the run-up rail out/in	3 - 45
installing the hose drum	3 - 41
installing/removing the anemometer	3 - 85
installing/removing the lifting limit switch	3 - 82
locking device on the hose drum	3 - 38
positioning/removing the hoist rope	3 - 80
preparing the truck crane for rigging	3 - 31
removing the hose drum	3 - 42
securing the lattice extension with rope	3 - 32
swinging the lattice extension onto the main boom	3 - 64
swinging the lattice extension when rigging	
when rigging section 1	3 - 65
when rigging section 2	3 - 67
when unrigging section 1	3 - 66
when unrigging section 2	3 - 68
unfolding/folding the deflection sheave	3 - 77
transport dimensions and weights	2 - 1
transporting	3 - 94
Lattice extension operating instructions	
basic safety instructions	1 - 2
important information	1 - 1

	intended use	1 - 3
	organizational measures	1 - 5
	personnel qualifications	1 - 7
	safety instructions for crane work	1 - 8
M	Maintenance work	
	on the boom extension	4 - 37
	on the lattice extension	3 - 123
	Malfunctions	
	when working with the swing-away lattice extension	3 - 121
P	Possible reeving methods	
	on the auxiliary single-sheave boom top	5 - 7
	on the boom extension	4 - 28
	on the heavy load lattice extension	6 - 16
	on the swing-away lattice extension	3 - 81
S	Safety instructions	
	warnings and symbols	1 - 2
	Swing-away lattice extension, see Lattice extension	
T	Transport	
	the auxiliary single-sheave boom top	5 - 5
	the heavy load lattice extension	6 - 19
	Transport dimensions and weights	
	12/21 m swing-away lattice extension	2 - 1
	auxiliary single-sheave boom top	2 - 2
	heavy load lattice extension	2 - 2
	Transporting	
	the 12/21 m swing-away lattice extension	3 - 33
	Turning loads	
	with the auxiliary single-sheave boom top	5 - 13
	with the heavy load lattice extension	6 - 29
	with the swing-away lattice extension	3 - 105

GROVE®

GMK 5220

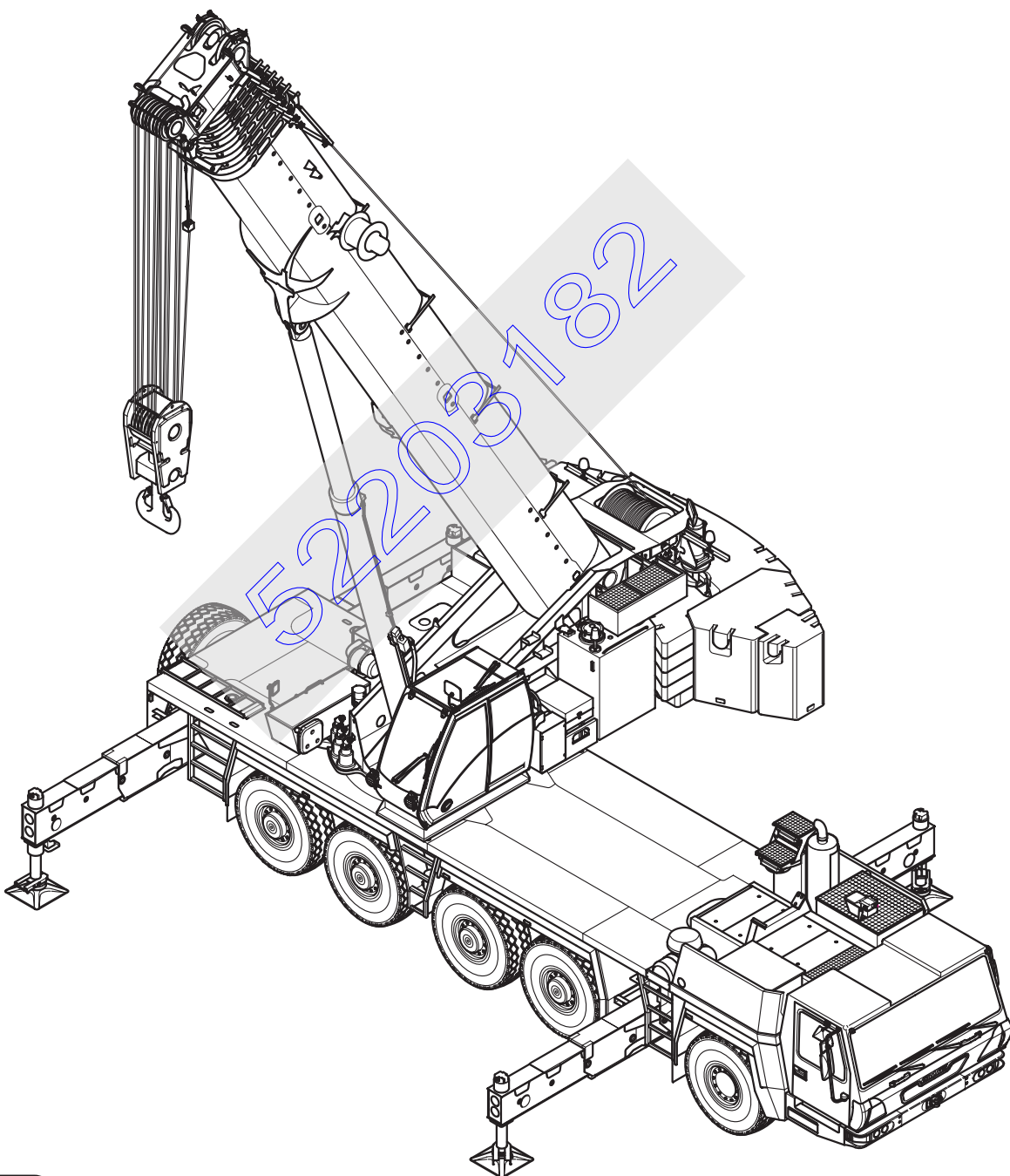

52203182

Deutsche GROVE GmbH

Industriegelände West,
D-26389 Wilhelmshaven, Germany
Postfach 18 53,
D-26358 Wilhelmshaven, Germany
Fax: Int [+49] (0) 44 21 294-301
Tel: Int [+49] (0) 44 21 294-0
www.groveworldwide.com