

# Manitowoc 18000

## Operator Manual



Grove

Manitowoc

National Crane

Potain





# WARNING



## California Proposition 65

Breathing diesel engine exhaust exposes you to chemicals known to the State of California to cause cancer and birth defects or other reproductive harm.

Always start and operate the engine in a well-ventilated area.

If in an enclosed area, vent the exhaust to the outside.

Do not modify or tamper with the exhaust system.

Do not idle the engine except as necessary.

For more information, go to [www.P65warnings.ca.gov/diesel](http://www.P65warnings.ca.gov/diesel)

Batteries, battery posts, terminals, and related accessories can expose you to chemicals, including lead and lead compounds, which are known to the State of California to cause cancer and birth defects or other reproductive harm. Wash hands after handling. For more information, go to [www.P65warnings.ca.gov](http://www.P65warnings.ca.gov)



## California Spark Arrestor

Operation of this equipment may create sparks that can start fires around dry vegetation. A spark arrestor may be required. The owner/ operator should contact local fire agencies for laws or regulations relating to fire prevention requirements.





# OPERATOR MANUAL

This manual has been prepared for and is considered part of -

**18000**

Crane Model Number

**180001Ref**

Crane Serial Number

This Manual is divided into the following sections:

<b>SECTION 1</b>	<b>INTRODUCTION</b>
<b>SECTION 2</b>	<b>SAFETY INFORMATION</b>
<b>SECTION 3</b>	<b>OPERATING CONTROLS AND PROCEDURES</b>
<b>SECTION 4</b>	<b>SET-UP AND INSTALLATION</b>
<b>SECTION 5</b>	<b>LUBRICATION</b>
<b>SECTION 6</b>	<b>MAINTENANCE CHECKLIST</b>

## NOTICE

The serial number of the crane and applicable attachments (i.e. luffing jib, MAX-ER<sup>®</sup>) is the only method your Manitowoc dealer or Manitowoc Product Support has of providing you with correct parts and service information.

The serial number is located on a crane identification plate attached to the operator's cab and each attachment. Refer to the Nameplate and Decal Assembly Drawing in Section 2 of this manual for the exact location of the crane identification plate.

**Always furnish serial number of crane and its attachments** when ordering parts or discussing service problems with your Manitowoc dealer or Manitowoc Product Support.

	<b>! WARNING</b>
	<p><b>To prevent death or serious injury:</b></p> <ul style="list-style-type: none"><li>• Avoid unsafe operation and maintenance. Crane and attachments must be operated and maintained by trained and experienced personnel. Manitowoc is not responsible for qualifying these personnel.</li><li>• Do not operate or work on crane or attachments without first reading and understanding instructions contained in Operator Information Manual and Service Manual supplied with crane and applicable attachments.</li><li>• Store Operator Information Manual and Service Manual in operator's cab. If Operator Information Manual or Service Manual is missing from cab, contact your Manitowoc Dealer for a new one.</li></ul>

**THE ORIGINAL LANGUAGE OF THIS PUBLICATION IS ENGLISH**

18001024

See end of this manual for Alphabetical Index

<b>SECTION 1</b> .....	<b>Introduction</b>
Crane Data .....	1-1
Crane/Attachment Identification .....	1-1
Change of Ownership Registration .....	1-1
Manitowoc Dealer .....	1-1
Crane Orientation .....	1-1
Identification And Location Of Components .....	1-2
Outline Dimensions .....	1-4
Crane Weights .....	1-6
English And Metric Conversions .....	1-11
Direct Conversion .....	1-11
Inverse Conversion .....	1-11
<b>SECTION 2</b> .....	<b>Safety Information</b>
Continuous Innovation .....	2-1
Nameplates and Decals .....	2-1
Safety Messages .....	2-1
General .....	2-1
Safety Alert Symbol .....	2-1
Signal Words .....	2-1
Symbol Identification .....	2-1
Safety and Information Signs .....	2-3
Maintaining Signs .....	2-3
Ordering Signs .....	2-3
Crane Access Points .....	2-4
General .....	2-4
Getting On or Off Crane .....	2-4
Personal Fall-Protection .....	2-7
Operator Manual/Capacity Chart Storage .....	2-7
General .....	2-7
Storing Manuals .....	2-7
Safe Operating Practices .....	2-8
General .....	2-8
Work Area Control .....	2-8
Read Operator Manual .....	2-8
Operator Qualifications .....	2-8
Operator Conduct .....	2-9
Handling Load .....	2-10
Signals .....	2-12
Safety Devices .....	2-13
Operational Aids .....	2-13
Category 1 Operational Aids .....	2-13
Category 2 Operational Aids .....	2-14
Assembling, Disassembling, or Operating Crane Near Electric Power and Transmission Lines .....	2-15
Electrocution Hazard .....	2-15
Set-Up and Operation .....	2-15
Electrical Contact .....	2-16
Refueling .....	2-16
Fire Extinguishers .....	2-16
Accidents .....	2-16
Safe Maintenance .....	2-17
Maintenance Instructions .....	2-17
Safe Maintenance Practices .....	2-17
Environmental Protection .....	2-18
Boom Disassembly Safety .....	2-20

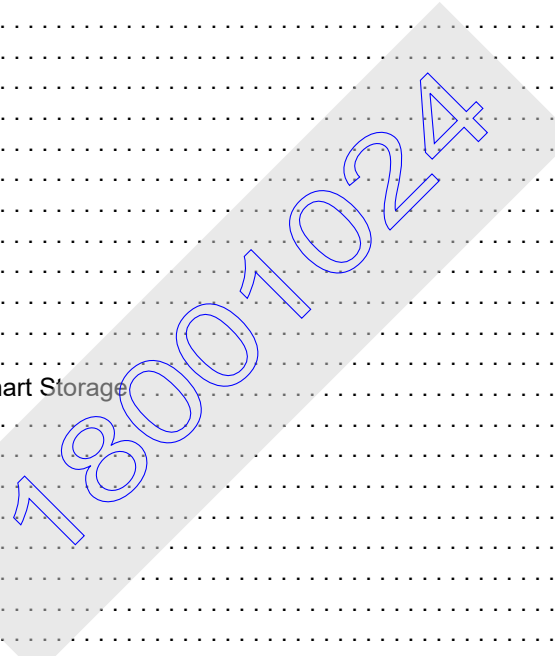

General . . . . . 2-20  
 Location . . . . . 2-20  
 Pin Removal . . . . . 2-20  
 Disassembly Precaution . . . . . 2-20  
 Special Application/Service . . . . . 2-21  
 Personnel Handling Policy . . . . . 2-21  
 Pedestal/Barge Mounted Cranes . . . . . 2-22  
     Pedestal Mounted Crane . . . . . 2-23  
     Barge Mounted Crane . . . . . 2-23  
     Capacity Charts for Barge Mounted Crane . . . . . 2-24  
     Shock Loading Caused by Barge Dynamics . . . . . 2-25  
     Operation on Barge . . . . . 2-25  
     Barge Mount Definitions . . . . . 2-25  
     Inspection of Barge-Mounted Crane . . . . . 2-25  
     Transporting Crane on Barge . . . . . 2-26  
 Pile Driving and Extracting . . . . . 2-26  
     Introduction . . . . . 2-26  
     Operation of Pile Driving and Extracting Equipment . . . . . 2-26  
     Crane Equipment . . . . . 2-26  
     Crane Inspection . . . . . 2-26  
 Electrocution Hazard Devices . . . . . 2-27  
 Multiple Load Line Operation . . . . . 2-27  
 Multiple Crane Lifts . . . . . 2-28

**SECTION 3 . . . . . Operating Controls And Procedures**

Standard Hand Signals for Controlling Crane Operations . . . . . 3-2  
 Symbol Identification . . . . . 3-4  
 Cab Door Adjustment . . . . . 3-11  
     General . . . . . 3-11  
     Closing Cab Door . . . . . 3-11  
     Damper Adjustment . . . . . 3-11  
 Front Window Operation . . . . . 3-12  
     Closing Window . . . . . 3-12  
     Opening Window For Ventilation . . . . . 3-12  
     Opening Window For Emergency Exit . . . . . 3-12  
 Crane Orientation . . . . . 3-12  
 Operating Controls . . . . . 3-12  
 Display Language . . . . . 3-12  
 Controls Identification And Function . . . . . 3-14  
     A – Engine Controls . . . . . 3-14  
     B – Accessory Controls . . . . . 3-17  
     C – Indicators . . . . . 3-21  
     D – Special Controls . . . . . 3-22  
     E – Boom/Luffing Hoist Controls . . . . . 3-28  
     F – Load Drum Controls . . . . . 3-29  
     G – Swing Controls . . . . . 3-30  
     J – Setup Controls . . . . . 3-31  
     K – Limit Devices . . . . . 3-31  
 Seat Controls . . . . . 3-34  
 Preparing Crane for Operation . . . . . 3-35  
 Calibration Procedures . . . . . 3-35  
 Operation . . . . . 3-36  
     Engine Startup . . . . . 3-36  
     Boom Hoist Operation . . . . . 3-38  
     Luffing Hoist Operation . . . . . 3-39  
     Swing Operation . . . . . 3-40

Load Drum Operation . . . . .	3-41
Travel Operation . . . . .	3-42
Stopping Engine/ Leaving Crane Unattended . . . . .	3-44
Remote Controls . . . . .	3-45
General . . . . .	3-45
Controls Identification and Operation . . . . .	3-45
Replacing Batteries in Setup Remote Control . . . . .	3-47
Digital Display Screens . . . . .	3-48
Crane Operating Conditions . . . . .	3-48
Operating Limits . . . . .	3-49
System Faults . . . . .	3-49
Function Speed/Torque Adjustment . . . . .	3-55
Engine Diagnostics . . . . .	3-55
General . . . . .	3-55
Onboard Engine Diagnostics . . . . .	3-56
Crane Diagnostics . . . . .	3-57
General . . . . .	3-57
Drum 1 . . . . .	3-57
Drum 2 . . . . .	3-58
Drum 3 . . . . .	3-58
Drum 4 . . . . .	3-58
Drum 5 . . . . .	3-59
Drum 6 . . . . .	3-59
Swing (Crane) . . . . .	3-59
Trk (Travel) . . . . .	3-60
FCN (Front Console Node) . . . . .	3-60
CAN (Can Bus) . . . . .	3-61
Hydraulic System Calibration . . . . .	3-63
Speed/Torque . . . . .	3-63
Accessory System . . . . .	3-63
Wireless . . . . .	3-63
Block Level Sensor . . . . .	3-64
Crane Mode . . . . .	3-64
Hydraulic Fan (Tier 4 only) . . . . .	3-64
MAX-ER Attachment . . . . .	3-65
Digital Input and Output Item Tables . . . . .	3-67
Hydraulic System Calibration Procedures . . . . .	3-71
General . . . . .	3-71
Pressure Sender Calibration . . . . .	3-71
Control Calibration . . . . .	3-73
Pump Pressure Test . . . . .	3-74
Charge Pressure Check . . . . .	3-76
Wind Conditions . . . . .	3-82
Cold Weather Heater Package . . . . .	3-85
General . . . . .	3-85
Heaters . . . . .	3-85
Turning Heaters On . . . . .	3-85
Turning Heaters Off . . . . .	3-85
Preparation for Cold Weather . . . . .	3-86
Crane Limitations . . . . .	3-86
Wire Rope . . . . .	3-86
Cold Weather Starting Aid . . . . .	3-86
Cooling System . . . . .	3-86
Battery . . . . .	3-86
Engine Oil . . . . .	3-87
Fuel Oil . . . . .	3-87
Gear Oil . . . . .	3-87

Hydraulic Oil ..... 3-87  
 Circuit Breakers ..... 3-87

**SECTION 4 ..... Set-Up and Installation**

Rigging Drawings ..... 4-1  
 Optional Attachments ..... 4-1  
 General Safety ..... 4-1  
 Crane Orientation ..... 4-1  
 Self-Erecting Equipment ..... 4-1  
 Assist Crane Requirements ..... 4-2  
 Assembly and Disassembly Notes ..... 4-2  
 Assembly And Disassembly Area ..... 4-2  
 Accessing Parts ..... 4-2  
 Crane Weights ..... 4-2  
 Handling Components ..... 4-2  
 Retaining Connecting Pins ..... 4-5  
 Cold Weather Mast Operation ..... 4-5  
 Shipping Crane Components ..... 4-8  
 Operating Controls ..... 4-8  
 Pre-Start Checks ..... 4-9  
     Engine ..... 4-9  
     Gear Boxes ..... 4-9  
     Hydraulic System ..... 4-9  
 Crane Assembly ..... 4-9  
     Rotating Bed Jack Pad Storage Location ..... 4-9  
     Remove Rotating Bed from Trailer ..... 4-10  
     Remove Carbody and Adapter Frame from Trailer ..... 4-16  
     Connect Rotating Bed to Carbody ..... 4-16  
     Lower Crane onto Carbody Pedestals ..... 4-18  
     Install Rotating Bed Catwalks and Steps (Past Production) ..... 4-20  
     Install Rotating Bed Side and Rear Catwalks and Steps (Current Production) ..... 4-22  
     Connect Hydraulic Hoses and Electric Cables ..... 4-22  
     Install Drum 3 (Whip Line Drum) ..... 4-22  
     Install Cab Left Platform (Current Production) ..... 4-24  
     Install Cab Rear Platform (Current Production) ..... 4-26  
     Move Platforms into Working Positions (Current Production) ..... 4-26  
     Configure Enclosure Panels ..... 4-29  
     Raise Live Mast To Operating Position ..... 4-31  
     Install Assembly Block ..... 4-33  
     Install Crawlers ..... 4-33  
     Install Counterweight ..... 4-39  
     Stow Mast Supports ..... 4-41  
     Deploy Mast Supports ..... 4-41  
     Remove Assembly Block ..... 4-43  
     Assemble Fixed Mast ..... 4-43  
     Perform Mast Pre-Raising Checks ..... 4-51  
     Raise Fixed Mast ..... 4-51  
     Assemble and Install Boom and Jib ..... 4-55  
 Pre-Raising Checks ..... 4-56  
 Raising Boom and Jib ..... 4-57  
 Crane Disassembly ..... 4-59  
     Lowering Boom And Jib ..... 4-59  
     Remove Rear Platforms and Catwalk (Past Production) ..... 4-65  
     Remove Rear Platforms and Catwalk (Current Production) ..... 4-65  
     Remove Crane Counterweight ..... 4-65  
     Install Assembly Block ..... 4-65



Remove Carbody Counterweight . . . . .	4-67
Deploy Rear Rotating Bed Jacks . . . . .	4-67
Remove Crawlers . . . . .	4-69
Remove Assembly Block . . . . .	4-73
Store Live Mast . . . . .	4-73
Remove Drum 3 (Whip Line Drum) . . . . .	4-73
Deploy Front Rotating Bed Jacks . . . . .	4-73
Separate Rotating Bed From Carbody . . . . .	4-74
Place Rotating Bed on Trailer . . . . .	4-74
Store Operator's Cab . . . . .	4-74
Remove Rotating Bed Jacks . . . . .	4-74
Install Wind Deflectors . . . . .	4-74
Boom Ladder Assembly . . . . .	4-76
General . . . . .	4-76
Removing Ladders from Boom Section . . . . .	4-76
Installing Ladders on Boom Inserts . . . . .	4-76
Storing Ladders . . . . .	4-76
Boom and Jib Rigging . . . . .	4-80
Assist Crane Requirements . . . . .	4-80
Blocked Crawler . . . . .	4-80
Handling Components . . . . .	4-80
Rigging Assembly Drawings . . . . .	4-80
Medium Inserts . . . . .	4-80
Identifying Boom and Jib Sections and Straps . . . . .	4-81
Boom Installation . . . . .	4-83
Boom Pre-Raising Checks . . . . .	4-99
Boom Removal . . . . .	4-102
Fixed Jib Installation . . . . .	4-105
Jib Removal . . . . .	4-114
Wire Rope Installation . . . . .	4-117
Wire Rope Storage . . . . .	4-117
Removing Wire Rope from Shipping Reel . . . . .	4-117
Seizing and Cutting Wire Rope . . . . .	4-117
Anchoring Wire Rope to Drum . . . . .	4-118
Winding Wire Rope onto Drum . . . . .	4-118
Anchoring Wire Rope to Socket And Wedge . . . . .	4-119
Anchoring Wire Rope to Button Socket . . . . .	4-121
Breaking in Wire Rope . . . . .	4-121
Pad Eye Usage for Wire Rope Reeving . . . . .	4-121
General . . . . .	4-121
Safety . . . . .	4-121
Rigging Winch Operation . . . . .	4-123
Selecting Rigging Winch Mode . . . . .	4-123
Operating Rigging Winch (Past Production) . . . . .	4-123
Operating Rigging Winch (Current Production) . . . . .	4-124
Load Block Reeving . . . . .	4-126
Load Block Identification . . . . .	4-126
Load Block Handling . . . . .	4-126
Wire Rope Specifications . . . . .	4-126
Wire Rope Installation and Maintenance . . . . .	4-126
Duplex Hook . . . . .	4-126
Guide Sheaves and Drums . . . . .	4-126
Load Block Reeving . . . . .	4-126
Block Level Sensor Adjustment . . . . .	4-136
General . . . . .	4-136
Sensor Adjustment . . . . .	4-136
Live Mast Reeving . . . . .	4-137

General ..... 4-137  
Wire Rope Specification ..... 4-137

**SECTION 5 ..... Lubrication**  
Lubrication ..... 5-1

**SECTION 6 ..... Maintenance Checklist**  
Inspection and Maintenance Checklist ..... 6-1  
Fiberglass Maintenance ..... 6-1



# SECTION 1 INTRODUCTION

## TABLE OF CONTENTS

Crane Data .....	1-1
Crane/Attachment Identification .....	1-1
Change of Ownership Registration .....	1-1
Manitowoc Dealer .....	1-1
Crane Orientation .....	1-1
Identification And Location Of Components .....	1-2
Outline Dimensions .....	1-4
Crane Weights .....	1-6
English And Metric Conversions .....	1-11
Direct Conversion .....	1-11
Inverse Conversion .....	1-11



**THIS PAGE INTENTIONALLY LEFT BLANK**

18001024

## SECTION 1

### INTRODUCTION

#### CRANE DATA

See the end of this section for crane data specific to your crane:

- Basic Specifications
- EC Declaration (if applicable)

#### CRANE/ATTACHMENT IDENTIFICATION

An identification plate is attached to the outside of the operator's cab (see [Figure 1-1](#)) and to the attachments (such as luffing jibs, MAX-ER, and Ringers) available for this crane.

The crane or attachment model and serial number are etched into the plate.

For the exact location of the identification plates on your crane and attachments, refer to the Nameplates and Decals Drawing in Section 2 of this manual.

#### CHANGE OF OWNERSHIP REGISTRATION

If you are the new owner of a Manitowoc crane, please register it with Manitowoc Product Support so we can contact you if the need arises.

1. Go to [www.manitowoc.com](http://www.manitowoc.com)
2. Go to SUPPORT>SERVICES>CHANGE OF OWNERSHIP.

3. Complete the form.

#### MANITOWOC DEALER

For questions about this manual or the 18000 crane, contact your Manitowoc dealer. If you do not know the contact information for your dealer, locate the Manitowoc dealer nearest you as follows:

1. Go to [www.manitowoc.com](http://www.manitowoc.com)
2. Click on the red FIND A DEALER button.
3. Follow the on-screen prompts to locate your Manitowoc dealer.

#### CRANE ORIENTATION

The terms RIGHT, LEFT, FRONT, REAR used in this manual refer to operator's right, left, front, and rear sides when seated in the operator's cab looking forward.

- Operator's cab is at front of upperworks.
- Crawler motors are at rear of lowerworks.
- Crawler pin handles on carbody are at front of lowerworks.

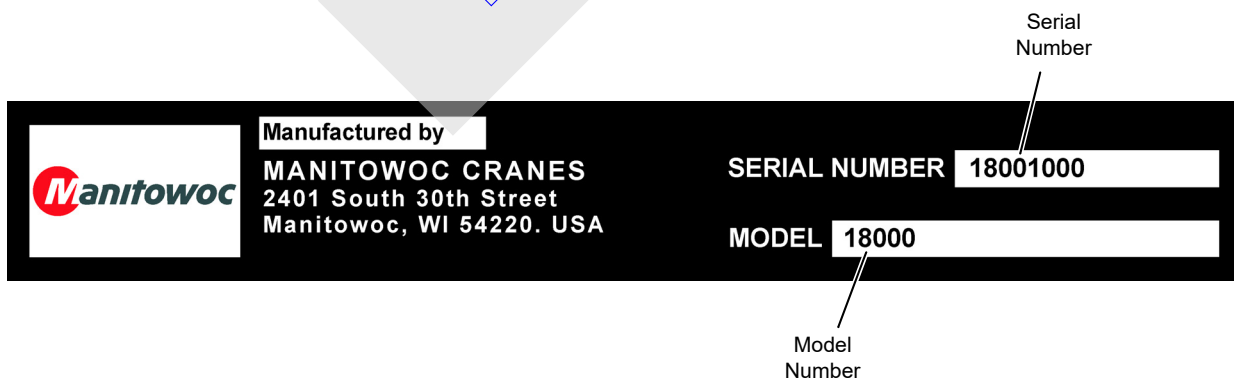
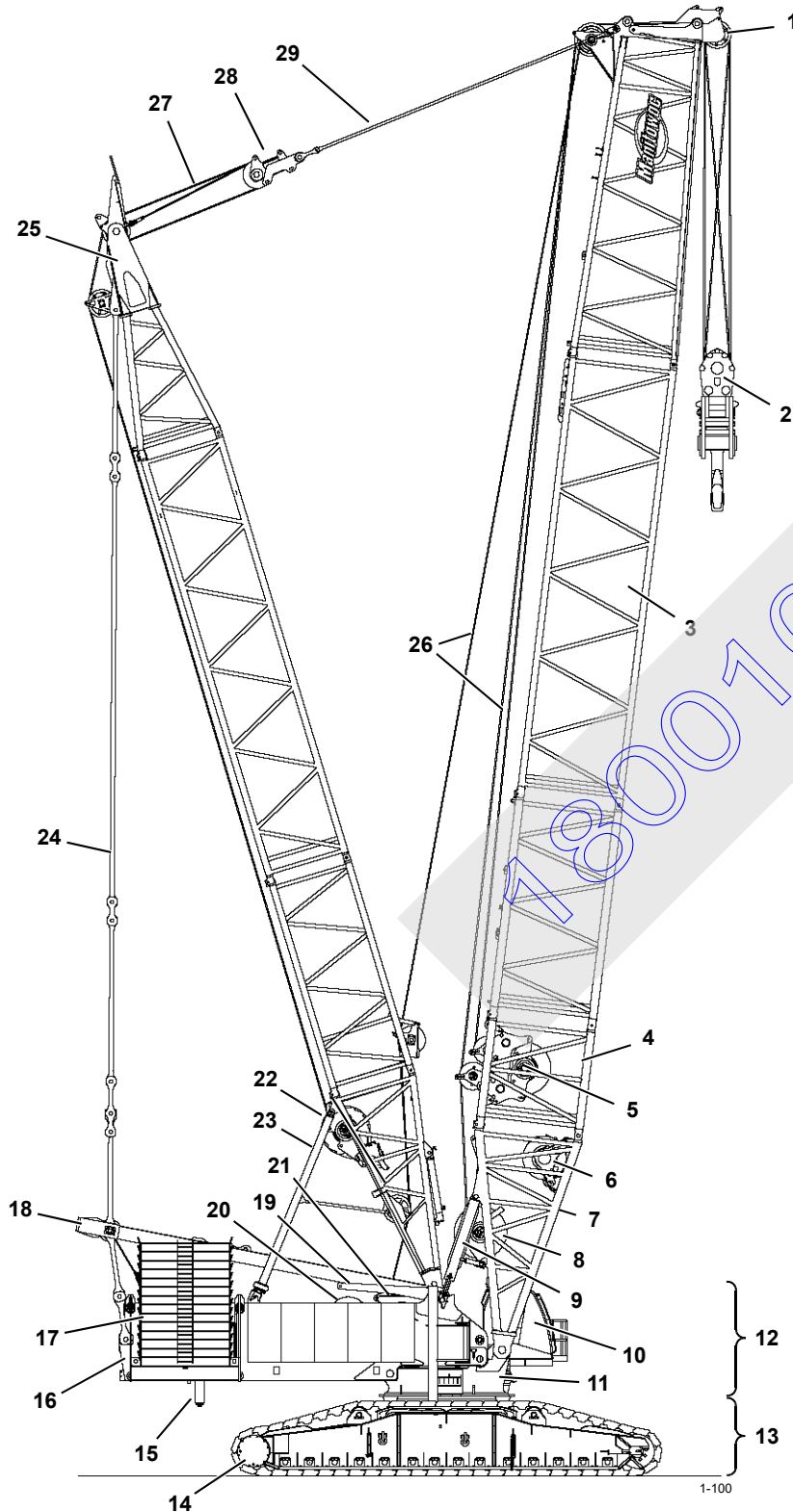

FIGURE 1-1

**IDENTIFICATION AND LOCATION OF COMPONENTS**



Item	Description
1	Boom Top
2	Load Block
3	Boom Insert (typical)
4	Boom Insert (with Drum 1)
5	Drum 1 (Main Hoist)
6	Drum 6 (Luffing Jib Hoist)
7	Boom Butt (with Drums)
8	Drum 2 (Main Hoist)
9	Telescopic Boom Stop
10	Operator's Cab
11	Adapter Frame
12	Upperworks
13	Lowerworks
14	Crawler (both sides)
15	Rotating Bed Jacks (4 each)
16	Rotating Bed
17	Upper Counterweights
18	Live Mast
19	Mast Assist Arm (2 each with cylinders)
20	Drum 5 (Mast Hoist)
21	Drum 3 (Whip Hoist)
22	Drum 4 (Boom Hoist)
23	Mast Stop
24	Mast Straps
25	Fixed Mast
26	Load Drum Wire Rope
27	Boom Hoist Wire Rope
28	Equalizer
29	Boom Straps

FIGURE 1-2



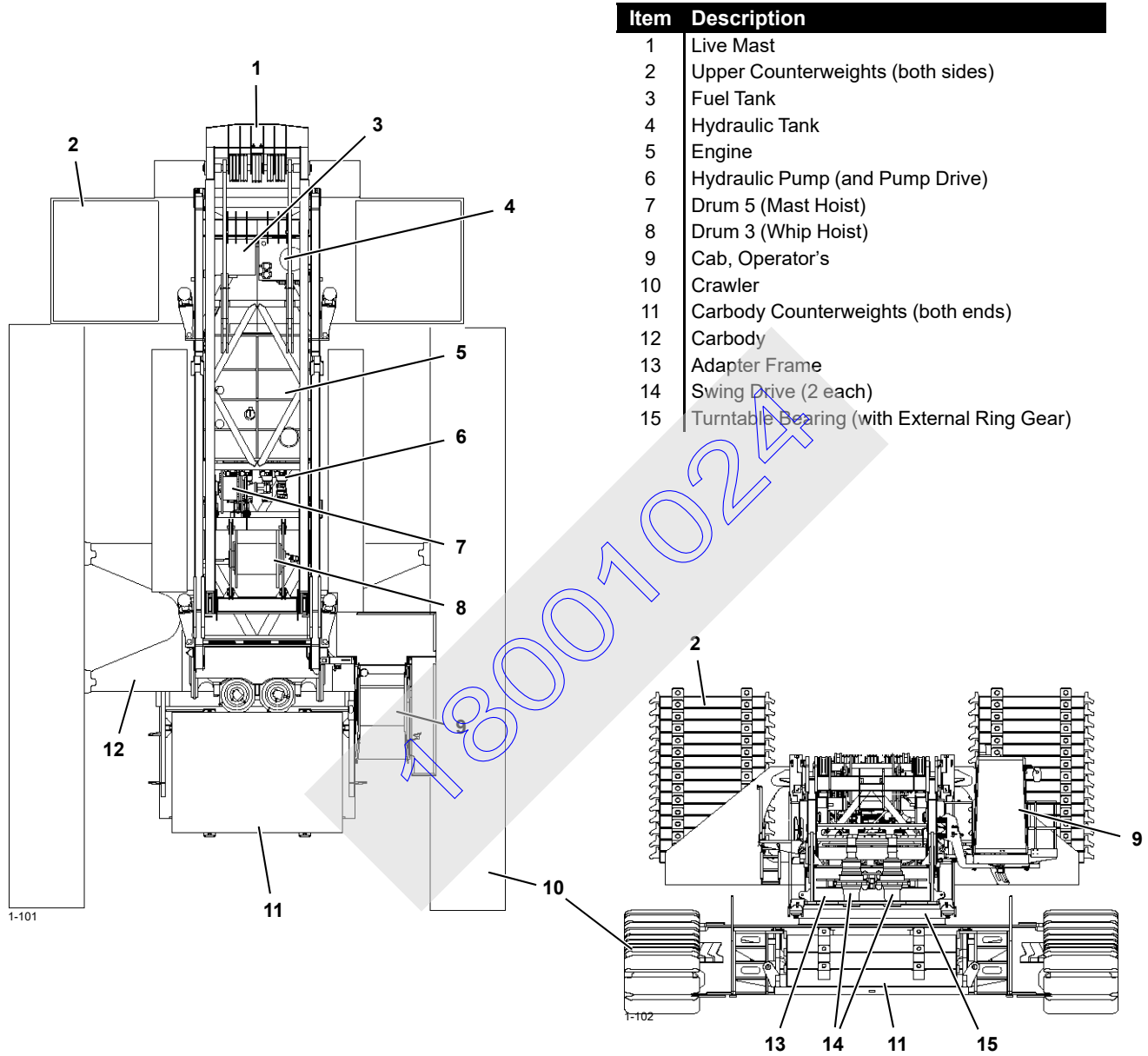
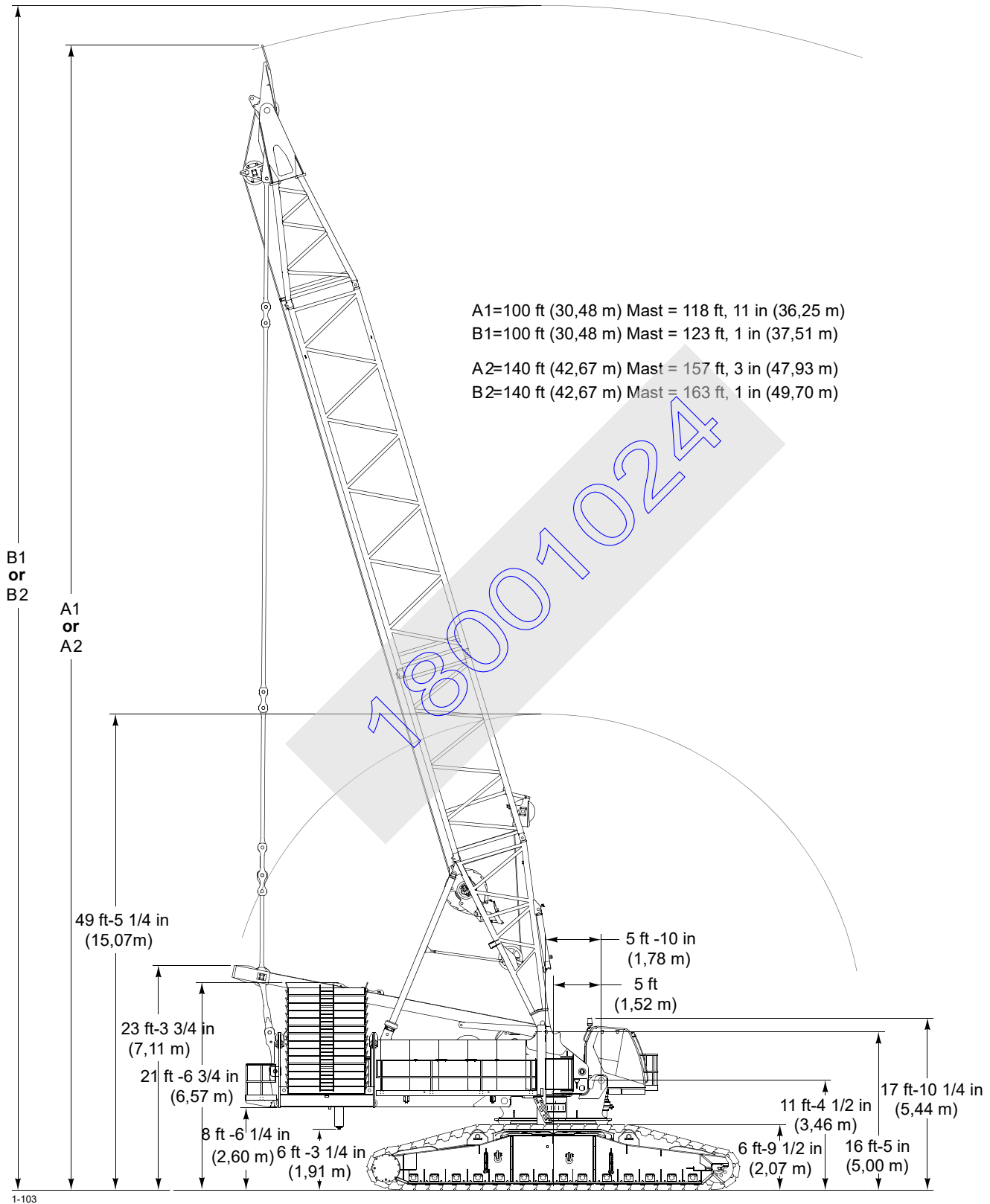

FIGURE 1-3

OUTLINE DIMENSIONS



Outline Dimensions Continued on Next Page

FIGURE 1-4

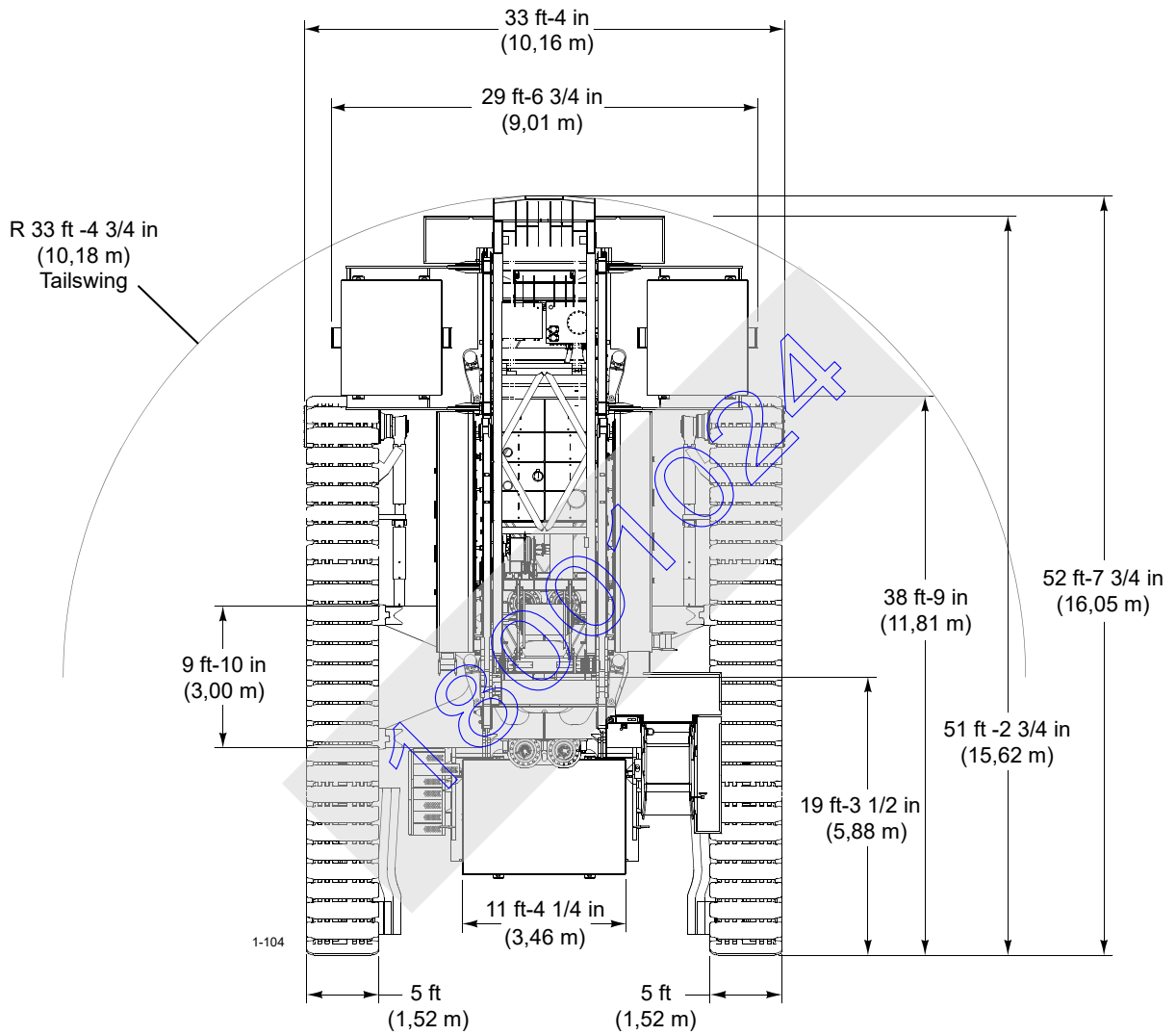

FIGURE 1-4 continued

**CRANE WEIGHTS**

Description	Weight	
	Pounds	Kilograms
<b>LIFTCRANE:</b>		
Upperworks and lowerworks complete, 4 swing drives, counterweight, 30 ft (9,1 m) live mast, backhitch, 100 ft (30,5 m) No. 56 Mast, mast stops, 30 USt (27 t) hook and weight ball, boom stops and load lines (includes self-erect and MAX-ER prep)		
When equipped with fully rigged 120 ft (36,6 m) Boom No. 55-79A, standard upper boom point, and 500 USt (454 t) block	1,478,930	670 831
When equipped with fully rigged 120 ft (36,6 m) Boom No. 55 or No. 55A, heavy duty upper boom point, and 661 USt (600 t) block	1,513,720	686 611
<b>UPPERWORKS REAR MACHINERY MODULE:</b>		
Rotating bed rear section with pin pullers, upperworks jacking system, 30 ft (9,1 m) live mast, mast hoist with mast hoist line, Cummins QXF15 power plant, hydraulic reservoir (full), fuel tank (1/2 full) and operators cab (drum 3 and catwalks removed)	104,435	47 370
Upperworks jacking system removed	88,335	40 068
<b>ADAPTER FRAME WITH CARBODY:</b>		
Rotating bed adapter frame with bearing turntable, 4 swing drives and carbody (includes MAX-ER prep)	95,900	43 499
<b>MAST NO. 56 BUTT/TOP SHIPPING PACKAGE:</b>		
20 ft (6,1 m) mast butt, boom hoist drum with rope, boom hoist drum guide rollers, wire rope guide sheave, mast stops, mast butt supports, boom equalizer, 20 ft (6,1 m) mast top with sheaves and straps (includes MAX-ER prep)	57,800	26 217
<b>BOOM NO. 55 BUTT SHIPPING PACKAGE:</b>		
20 ft (6,1 m) boom butt, load hoist drum with rope, luffing drum with rope, rigging winch with rope, cable reel, boom stops and boom hinge pin-pullers	57,875	26 251
<b>BOOM NO. 55 - 10 ft (3,0m) INSERT SHIPPING PACKAGE:</b>		
10 ft (3,0 m) insert, load hoist drum with rope and wire rope guide	35,960	16 311
<b>CRAWLERS:</b>		
38 ft 9 in (11,8 m) crawler assembly (each) with drive and 60 in (1 524 mm) treads	88,255	40 031
<b>COUNTERWEIGHT - UPPER:</b>		
Tray (each)	12,050	5 465
Counterweight (28 total) (each)	18,000	8 164
Rear catwalk with railings	1,290	585
Total upperworks counterweight	528,000	239 496
<b>COUNTERWEIGHT - LOWER:</b>		
Counterweight tray (each)	28,000	12 700
Counterweight (each) (6 total - 3 front, 3 rear)	44,000	19 958
Stairway (each)	250	113
Total lowerworks counterweight	320,000	145 149
<b>30 ft (9,1 m) LIVE MAST:</b>		
30 ft (9,1 m) mast with straps	9,660	4 381
<b>MACHINE OPTIONS:</b>		
Drum 3 assembly (whip line without rope)	5,250	2 381
Upperworks jacking system	14,700	6 667
Swing drive assemblies (each)	1,765	800
Rotating bed alignment pendants (each)	65	29
<b>LOWERWORKS OPTIONS:</b>		
Carbody pedestals with pads (each)	410	185
<b>MAST NO. 56:</b>		
20 ft (6,1 m) mast butt with boom hoist drum with rope and guide sheave	33,905	15 379
20 ft (6,1 m) mast top with sheaves, wire rope guide and straps	20,485	9 291
40 ft (12,2 m) insert with straps	13,940	6 323
20 ft (6,1 m) insert with straps	8,490	3 850

Description	Weight	
	Pounds	Kilograms
7 ft 1 in (2,2 m) upper backhitch strap (each)	485	219
13 ft 4-1/4 in (4,1 m) lower backhitch strap (each)	615	278
40 ft (12,2 m) backhitch strap (with connector links) (each)	1,805	818
14 ft 8 in (4,5 m) backhitch strap (each)	665	301
Mast stop tube (each) with strut and pins	1,030	467
Mast support (each)	335	151
Wire rope guide (on mast butt for whip line)	490	222
Wire rope guide (on 20 ft [6,1 m] insert for whip line)	600	272
Boom hoist drum without rope	8,110	3 678
<b>BOOM NO. 55-79A:</b>		
20 ft (6,1 m) butt No. 55	18,440	8 364
30 ft (9,1 m) top with straps, upper and lower point and wire rope guide	26,620	12 074
20 ft (6,1 m) insert No. 79 with straps	7,260	3 293
40 ft (12,2 m) insert No. 79 with straps	12,130	5 502
40 ft (12,2 m) transition insert No. 55-79 with links	12,110	5 493
10 ft (3,0 m) insert No. 55	7,680	3 483
20 ft (6,1 m) insert No. 55	10,715	4 860
40 ft (12,2 m) insert No. 55 with sheaves	19,640	8 908
28 ft 2-15/16 in (8,6 m) basic strap (each)	355	161
20 ft (6,1 m) strap (with connector links) (each)	290	131
40 ft (12,2 m) strap (with connector links) (each)	525	238
Links (attached to equalizer) (each set) with pins	95	43
Equalizer with pins	3,675	1 666
Boom stop (each tube)	1,795	814
Drum 1 or 2 assembly (load hoist without rope)	9,970	4 522
<b>BOOM NO. 55 OR NO. 55A:</b>		
20 ft (6,1 m) butt	18,440	8 364
30 ft (9,1 m) top with straps, upper and lower point and wire rope guide	40,700	18 461
10 ft (3,0 m) insert	7,680	3 483
20 ft (6,1 m) insert	10,715	4 860
40 ft (12,2 m) insert	18,485	8 384
40 ft (12,2 m) insert with equalizer rails	19,185	8 702
40 ft (12,2 m) insert (medium)	13,685	6 207
40 ft (12,2 m) insert with sheaves	19,640	8 908
28 ft 2-11/16 in (8,6 m) basic strap (each)	755	342
20 ft (6,1 m) strap (with connector links) (each)	610	276
40 ft (12,2 m) strap (with connector links) (each)	1,120	508
Links (attached to equalizer) (each set) with pins	110	49
Equalizer with pins	3,675	1 666
Boom stop (each tube)	1,795	814
Drum 1 or 2 assembly (load hoist without rope)	9,970	4 522
<b>LUFFING JIB NO. 44:</b>		
40 ft (12,2 m) butt	8,605	3 903
12 ft (3,7 m) lower butt	4,430	2 009
28 ft (8,5 m) upper butt	5,305	2 406
30 ft (9,1 m) top with straps, upper and lower point	14,090	6 391
10 ft (3,0 m) insert No. 44	1,890	857
20 ft (6,1 m) insert No. 44	3,215	1 458
40 ft (12,2 m) insert No. 44	5,420	2 458
Luffing jib adapter	4,600	2 086
31 ft 1-3/16 in (9,5 m) basic strap (each)	400	181
20 ft (6,1 m) strap (with connector links) (each)	290	131
40 ft (12,2 m) strap (with connector links) (each)	525	238
Adjustable strap (each) with pins	1,565	709

Description	Weight	
	Pounds	Kilograms
50 ft (15,2 m) jib strut with guide sheave, luffing sheaves and links	13,285	6 025
47 ft (14,3 m) main strut with luffing sheaves and links	9,425	4 275
Luffing wire rope guide	1,070	485
38 ft 2 in (11,6 m) backstay basic strap (with connector links) (each)	510	231
10 ft (3,0 m) backstay strap (with connector links) (each)	175	79
20 ft (6,1 m) backstay strap (with connector links) (each)	290	131
40 ft (12,2 m) backstay strap (with connector links) (each)	525	238
40 ft (12,2 m) transition backstay strap (with connector links) (each)	525	238
10 ft (3,0 m) No. 55 backstay strap (with connector links) (each)	405	183
20 ft (6,1 m) No. 55 backstay strap (with connector links) (each)	675	306
40 ft (12,2 m) No. 55 backstay strap (with connector links) (each)	1,220	553
Backstay link (attached to boom butt) (each)	115	52
Luffing jib stop assembly	1,850	839
Upper point (single sheave) with rollers	1,220	553
<b>FIXED JIB NO. 79A:</b>		
20 ft (6,1 m) butt No. 79A	10,295	4 669
30 ft (9,1 m) top with double straps, upper (heavy duty) and lower point and wire rope guide	27,780	12 600
20 ft (6,1 m) insert No. 79 with double straps	7,835	3 553
40 ft (12,2 m) insert No. 79 with double straps	13,180	5 978
28 ft 2-15/16 in. (8,6 m) basic strap (each)	355	161
20 ft (6,1 m) jib strap with links (each)	290	131
40 ft (12,2 m) jib strap with links (each)	525	238
Equalizing link (each)	375	170
10 ft (3,0 m) strap (with connector links) (each) (20 degree offset)	355	161
7 ft (2,1 m) strap (with connector links) (each)	345	156
4 ft 9 in (1,4 m) strap with pin (each)	195	88
4 ft 9 in (1,4 m) link with pin (set each)	185	83
6 ft 2 in (1,9 m) strap with pin (each)	265	120
Jib stop assembly (each)	1,890	857
Jib hinge pins/link assembly (each)	340	154
29 ft (8,8 m) strut butt	5,325	2 415
21 ft (6,4 m) strut top	4,625	2 097
1 ft 5 in (0,4 m) spreader link with pins	690	312
1 ft 10 in (0,6 m) link with pins (each)	225	102
1 ft 10 in (0,6 m) link (each)	135	61
1 ft 7 in (0,5 m) spreader link with pins (each)	535	242
Adjustable link with pins (each)	585	265
7 ft 4 in (2,2 m) backstay strap (each)	275	124
30 ft (9,1 m) backstay strap with links (each)	865	392
20 ft (6,1 m) backstay strap with links (each)	610	276
40 ft (12,2 m) backstay strap with links (each)	1,120	508
10 ft (3,0 m) backstay strap with links (each)	355	161
1 ft 11-1/2 in (0,6 m) backstay link, pins (each set)	115	52
<b>LUFFING JIB NO. 79A:</b>		
20 ft (6,1 m) butt No. 79A	10,315	4 678
30 ft (9,1 m) top with double straps, upper (heavy duty) and lower point and wire rope guide	27,835	12 625
20 ft (6,1 m) insert No. 79 with double straps	7,835	3 553
20 ft (6,1 m) insert No. 79 without straps	6,700	3 039
40 ft (12,2 m) insert No. 79 with double straps	13,180	5 978
28 ft 2-15/16 in (8,6 m) basic strap (each)	355	161
20 ft (6,1 m) jib strap with links (each)	290	131
40 ft (12,2 m) jib strap with links (each)	525	238
Equalizing link (each)	375	170
8.63 in (0,2 m) link, pins (each set)	85	38



Description	Weight	
	Pounds	Kilograms
17 ft 10-1/2 in (5,4 m) strap (each)	495	224
1 ft 6 in (0,5 m) link (each)	115	52
Spreader with pins	180	81
13 ft 10-1/4 in (4,2 m) strap	850	385
Spreader link, pins	100	45
1 ft 6 in (0,5 m) link (each)	120	54
4 ft 2 in (1,3 m) strap, pin (each)	380	172
Jib hinge pins/link assembly (each)	340	154
Jib stop assembly (each)	2,715	1 231
Automatic jib stop assembly	40	18
30 ft (9,1 m) jib strut top with point sheaves	8,790	3 987
29 ft (8,8 m) jib strut butt with wire rope guide	5,900	2 676
21 ft (6,4 m) main strut top with point sheaves and raising pendant	8,550	3 878
29 ft (8,8 m) main strut butt	5,365	2 433
Main strut stop assembly (each)	1,980	898
8 ft 9-1/4 in (2,7 m) strap (each)	260	117
4 ft (1,2 m) link with pins (each set)	180	81
3 ft 10-1/2 in (14,2 m) adjustable strap (each)	160	72
20 ft (6,1 m) backstay strap with link (each)	610	276
40 ft (12,2 m) backstay strap with link (each)	1,120	508
10 ft (3,0 m) backstay strap with link (each)	360	163
1 ft 11-1/2 in (0,6 m) backstay link with pin (each set)	115	52
Boom dolly with adapter frame, pins	7,800	3 538
<b>BOOM OPTIONS:</b>		
Drum 6 assembly (luffing hoist with rope)	11,615	5 268
Standard upper boom point (single sheave)	1,115	505
Heavy duty upper boom point (single sheave)	1,630	739
25 FT. (7.6m) extended upper boom point with load sensor	10,570	4 794
661 USt (600 t) Load Block	25,100	11 385
500 USt (454 t) load block	24,500	11 113
496 USt (450 t) load block	24,710	11 205
450 USt (408 t) load block	21,300	9 661
350 USt (318 t) load block	17,400	7 892
276 USt (250 t) load block	19,300	8 750
110 USt (100 t) load block	10,260	4 650
100 USt (91 t) load block (self-erect)	3,900	1 769
30 USt (27 t) hook and weight ball	2,800	1 270
15 USt (14 t) hook and weight ball	1,800	816

Description	Weight	
	Pounds	Kilograms
<b>WIRE ROPE:</b>		
<b>Mast hoist</b>		
1,230 ft (375 m) of 22 mm wire rope - 1.80 lb per ft (2,68 kg/m) - - - - -	2,215	1 004
<b>Boom hoist</b>		
4,370 ft (1 332 m) of 1-1/8 in (28,6 mm) wire rope - 2.60 lb per ft (3,87 kg/m) - - - - -	11,360	5 152
<b>Luffing Jib Hoist</b>		
1 in. (25,4 mm) wire rope - 2.00 lb per ft (2,98 kg/m)		
1,700 ft (518 m) No. 44 Luffing Jib - - - - -	3,400	1 542
3,100 ft (945 m) No. 79A Luffing Jib - - - - -	6,200	2 812
<b>Load lines</b>		
32 mm wire rope - 3.74 lb per ft (5,57 kg/m)		
3,700 ft (1 128 m) Drum 1 - - - - -	13,840	6 277
3,400 ft (1 036 m) Drum 2 - - - - -	12,715	5 767
28 mm wire rope - 2.76 lb per ft (4,11 kg/m)		
4,800 ft (1 463 m) Drum 1 - - - - -	13,250	6 010
4,000 ft (1 158 m) Drum 2 - - - - -	11,040	5 007
<b>Whip lines</b>		
28 mm wire rope - 2.76 lb per ft (4,11 kg/m)		
1,900 ft (579 m) Drum 3 - - - - -	5,245	2 379

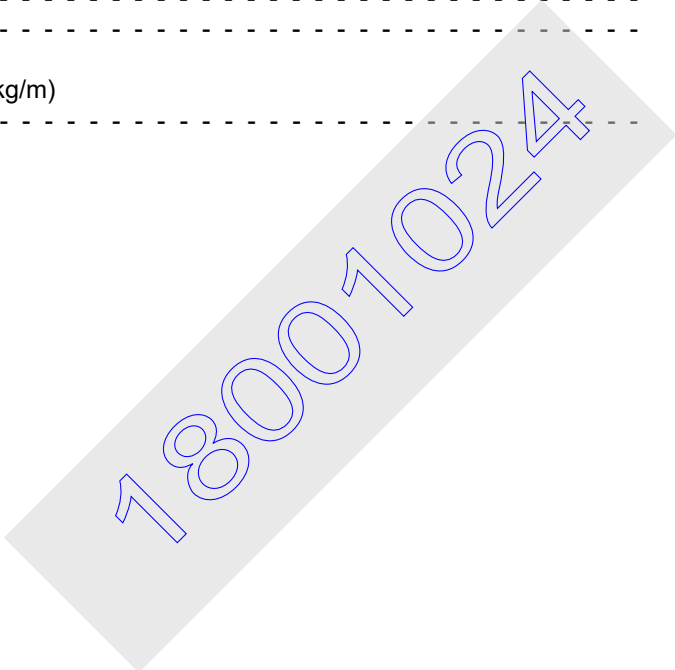

## ENGLISH AND METRIC CONVERSIONS

## Direct Conversion

MULTIPLY (x) known value by conversion factor to obtain equivalent value in desired units. For example, 12 ft is converted to meters (m), as follows:

$$12 \text{ ft} \times 0.3048 = 3,6576 \text{ m}$$

## Inverse Conversion

DIVIDE (/) known value by conversion factor to obtain equivalent value in desired units. For example, 3,6576 m is converted to feet, as follows:

$$3,6576 \text{ m} / 0.3048 = 12$$

To Convert	Symbol	Application	To	Symbol	Multiply By
<b>AREA</b>					
Square Inch	in <sup>2</sup>	Filter Area Clutch Contact	Square Centimeter	cm <sup>2</sup>	6.4516
Square Foot	ft <sup>2</sup>	Ground Contact	Square Meter	m <sup>2</sup>	0.0929
<b>FORCE</b>					
Pound Force	lb	Pedal Effort	KiloNewton Newton	kN N	0.00445 4.4482
Pound Force	lb	Line Pull	KiloNewton	kN	0.00445
Pound Force Per Inch	lb/in.	Spring Force	Newton per millimeter	Nmm	0.1751
Pound Force Per Foot	lb/ft		Newton per meter	Nm	14.5939
<b>LENGTH</b>					
Inch	in.	Adjustments	Millimeter	mm	25.4000
Foot	ft	Outline Dimensions	Meter	m	0.3048
Mile	miles	Travel Distance	Kilometer	km	1.6093
<b>POWER</b>					
Horsepower	hp	Engine	Kilowatt	kW	0.7457
<b>PRESSURE</b>					
Pound/Sq. In.	psi	Hydraulic & Air	Bar		0.0689
<b>TEMPERATURE</b>					
Degrees Fahrenheit	°F	Oil, Air, Etc.	Degrees Centigrade	°C	°F - 32 / 1.8
Degrees Centigrade	°C		Degrees Fahrenheit	°F	°C x 1.8 + 32
<b>TORQUE</b>					
Inch Pound	in lb	Bolt Torque	Newton Meter	Nm	0.1129
Foot Pound	ft lb		Newton Meter	Nm	1.3558
<b>VELOCITY</b>					
Miles Per Hour	mph	Vehicle Speed	Kilometers Per Hour	km/h	1.6093
Miles Per Hour	mph	Wind Speed	Meters Per Second	m/s	0.4470
Feet Per Minute	fpm	Line Speed	Meters Per Minute	m/min	0.3048
<b>VOLUME</b>					
Cubic Yard	yd <sup>3</sup>	Bucket Capacity	Cubic Meter	m <sup>3</sup>	0.7646
Cubic Foot	ft <sup>3</sup>		Cubic Meter	m <sup>3</sup>	0.0283
Cubic Inch	in <sup>3</sup>	Pump Displacement	Cubic Centimeter	cm <sup>3</sup>	16.3871

To Convert	Symbol	Application	To	Symbol	Multiply By
<b>VOLUME (LIQUID)</b>					
Ounce	oz	Fluid Capacities	Milliliter	mL	29.5735
Pint	pt		Liter	L	0.4732
Quart	qt		Liter	L	0.9464
Gallon	gal		Liter	L	3.7854
Gallon Per Minute	gpm	Pump Flow	Liters Per Minute	L/min	3.7854
<b>WEIGHT</b>					
Pound	lb	Unit/Component	Kilogram	kg	0.4536
US Ton (2000 lb)	USt	Load Ratings	Metric Ton	t	0.9072
US Ton (2000 lb)	USt		Kilogram	kg	907.1847

18001024

## SECTION 2

### SAFETY INFORMATION

#### TABLE OF CONTENTS

Continuous Innovation .....	2-1
Nameplates and Decals .....	2-1
Safety Messages .....	2-1
General .....	2-1
Safety Alert Symbol .....	2-1
Signal Words .....	2-1
Symbol Identification .....	2-1
Safety and Information Signs .....	2-3
Maintaining Signs .....	2-3
Ordering Signs .....	2-3
Crane Access Points .....	2-4
General .....	2-4
Getting On or Off Crane .....	2-4
Personal Fall-Protection .....	2-7
Operator Manual/Capacity Chart Storage .....	2-7
General .....	2-7
Storing Manuals .....	2-7
Safe Operating Practices .....	2-8
General .....	2-8
Work Area Control .....	2-8
Read Operator Manual .....	2-8
Operator Qualifications .....	2-8
Operator Conduct .....	2-9
Handling Load .....	2-10
Size of Load .....	2-10
Attaching Load .....	2-11
Lifting/Moving Load .....	2-11
Holding Load .....	2-12
Signals .....	2-12
Safety Devices .....	2-13
Operational Aids .....	2-13
Category 1 Operational Aids .....	2-13
Category 2 Operational Aids .....	2-14
Assembling, Disassembling, or Operating Crane Near Electric Power and Transmission Lines .....	2-15
Electrocution Hazard .....	2-15
Set-Up and Operation .....	2-15
Electrical Contact .....	2-16
Refueling .....	2-16
Fire Extinguishers .....	2-16
Accidents .....	2-16
Safe Maintenance .....	2-17
Maintenance Instructions .....	2-17
Safe Maintenance Practices .....	2-17
Environmental Protection .....	2-18
Boom Disassembly Safety .....	2-20
General .....	2-20
Location .....	2-20
Pin Removal .....	2-20
Disassembly Precaution .....	2-20
Special Application/Service .....	2-21
Personnel Handling Policy .....	2-21

18001024

Pedestal/Barge Mounted Cranes .....	2-22
Pedestal Mounted Crane .....	2-23
Definition .....	2-23
Examples .....	2-23
Barge Mounted Crane .....	2-23
Definition .....	2-23
Examples .....	2-23
Capacity Charts for Barge Mounted Crane .....	2-24
Shock Loading Caused by Barge Dynamics .....	2-25
Operation on Barge .....	2-25
Barge Mount Definitions .....	2-25
Inspection of Barge-Mounted Crane .....	2-25
Transporting Crane on Barge .....	2-26
Pile Driving and Extracting .....	2-26
Introduction .....	2-26
Operation of Pile Driving and Extracting Equipment .....	2-26
Crane Equipment .....	2-26
Crane Inspection .....	2-26
Electrocution Hazard Devices .....	2-27
Multiple Load Line Operation .....	2-27
Multiple Crane Lifts .....	2-28

18001024



## SECTION 2

### SAFETY INFORMATION



#### WARNING

##### California Proposition 65

Breathing diesel engine exhaust exposes you to chemicals known to the State of California to cause cancer and birth defects or other reproductive harm.

- Always start and operate the engine in a well-ventilated area.
- If in an enclosed area, vent the exhaust to the outside.
- Do not modify or tamper with the exhaust system.
- Do not idle the engine except as necessary.

For more information go to [www.P65warnings.ca.gov/diesel](http://www.P65warnings.ca.gov/diesel).

Batteries, battery posts, terminals, and related accessories can expose you to chemicals, including lead and lead compounds, which are known to the State of California to cause cancer and birth defects or other reproductive harm. Wash hands after handling. For more information go to [www.P65warnings.ca.gov](http://www.P65warnings.ca.gov).

##### California Spark Arrestor

Operation of this equipment may create sparks that can start fires around dry vegetation. A spark arrestor may be required. The owner/operator should contact local fire agencies for laws or regulations relating to fire prevention requirements.

#### CONTINUOUS INNOVATION

Due to continuing product innovation, the information in this manual is subject to change without notice. If you are in doubt about any procedure, contact your Manitowoc dealer or Manitowoc Product Support.

#### NAMEPLATES AND DECALS

See the drawing at the end of this section.

#### SAFETY MESSAGES

##### General

The importance of safe operation and maintenance cannot be over emphasized. Carelessness or neglect on the part of operators, job supervisors and planners, rigging personnel,

and job site workers can result in their death or injury and costly damage to the crane and property.

To alert personnel to hazardous operating practices and maintenance procedures, safety messages are used throughout the manual. Each safety message contains a safety alert symbol and a signal word to identify the hazard's degree of seriousness.

#### Safety Alert Symbol



This is the safety alert symbol. It is used to alert you to potential personal injury hazards. **Obey all safety messages that follow this symbol to avoid possible death or injury.**

#### Signal Words



#### DANGER

Indicates a hazardous situation which, if not avoided, will result in death or serious injury.



#### WARNING

Indicates a hazardous situation which, if not avoided, could result in death or serious injury.



#### CAUTION

Used with the safety alert symbol, indicates a hazardous situation which, if not avoided, could result in minor or moderate injury.

#### CAUTION

Without the safety alert symbol, identifies potential hazards that could result in property damage.

**NOTE** Highlights operation or maintenance procedures.

#### Symbol Identification

Many of the symbols used in the safety and information signs and nameplates on this crane are identified in [Table 2-1 on page 2-2](#) and [Table 2-2 on page 2-3](#).

Table 2-1 Common Safety Symbols















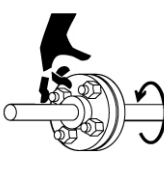

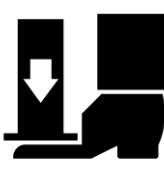











<b>Cut or Crush Hazards</b>					<b>Cut Hazard</b>
 M100090	 M100091	 M100066	 M100065	 M100069	 M100067
<b>Crush Hazards</b>					<b>Fire Extinguisher</b>
 M100070	 M100071	 M100072	 M100073	 M100074	 M100082
<b>Fall Hazards</b>			<b>Falling Boom (Crush) Hazards</b>		<b>Explosion Hazard</b>
 M100083	 M100084	 M100085	 M100068	 M100075	 M100080
<b>Falling Load Hazards</b>		<b>Flying Objects Hazards</b>			<b>Overhead Obstruction Hazard</b>
 M100076	 M100077	 M100088	 M100088	 M100089	 M100081
<b>Electrocution Hazards</b>		<b>Personal Fall Protection</b>	<b>Pressure Cleaning</b>	<b>Sound Power Level</b>	<b>Read Manual</b>
 M100078	 M100079	 M100095	 M100087	 M100096	 M100093

Table 2-1 Common Safety Symbols



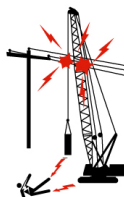

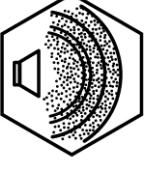









Emergency Cab Exit	Lift	Do Not Lift	Prohibited
 M102486	 M104626	 M104627	 M104628

Table 2-2 Miscellaneous Symbols

Diesel Fuel	Engine Coolant	Engine Coolant Vent	Engine Oil Level	Hydraulic Filter	Hydraulic Oil
 M100271	 M100267	 M100268	 M100269	 M100272	 M100273
<b>Pump Drive Oil Level</b>	<b>Tire Pressure (if equipped)</b>				
 M100270	 M100266	 M101972	 M101973	 M101974	

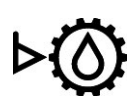
**SAFETY AND INFORMATION SIGNS**

**Maintaining Signs**

The crane owner/user shall make sure that all safety and information signs are legible and installed at the proper locations on the crane. If a sign has been defaced or removed, it must be replaced immediately. See the Nameplate and Decal Drawing at the end of this section for the installation locations of signs.

**Ordering Signs**

Order replacement safety and information signs from your Manitowoc dealer.

When ordering a sign, give the crane model number, the crane serial number, and the name and part number of the sign.

## CRANE ACCESS POINTS



### WARNING

#### Crush Hazard!

The upperworks can swing into and crush personnel climbing on or off the crane.

Moving crawlers can crush personnel climbing on or off the crane.

To prevent death or serious injury:

- Barricade all accessible areas to the crane so personnel cannot be struck or crushed when the upperworks is swung.
- Do not climb onto or off the crane while the upperworks is being swung or the crane is being traveled.
- Signal the operator for permission to climb onto/off the crane.
- Operator: do not swing or travel while personnel are climbing onto or off the crane. Stop the swing and travel motions. Apply the swing brake and turn on travel park.
- Operator: Always sound the horn to alert personnel before you swing or travel.
- Automatic alarms will sound to alert personnel when the crane is swung or traveled.

**NOTE** If the swing and travel alarms are not operating properly, they must be repaired as soon as possible. Until they are repaired, the operator shall alert personnel to crane movement using the horn on the control console.

## General

Take necessary precaution to prevent slipping and/or falling off the crane during assembly, disassembly, maintenance, or other work. **Falling from any height could result in serious injury or death.**

Manitowoc has provided a ladder, steps, platforms, and catwalks at the locations shown in

The owner/user shall provide workers with approved ladders or aerial work platforms to access those areas of the crane, gantry, and boom that cannot be reached from the ground or from the ladder, steps, platforms, and catwalks provided by Maniowoc.

Adhere to local, state, and federal regulations for handling personnel and for personnel fall protection.

- Access points must be kept clear to prevent personal injury and unsafe operation of the crane. Store clothing and other personal belongings so they do not interfere with controls in operator cab or with operation of the crane.
- Do not allow ground personnel to store their personal belongings (clothing, lunch boxes, water coolers, and the like) on the crane.

This practice will prevent ground personnel from being crushed or electrocuted when they attempt to access personal belongings stored on the crane.

- Tools, oil cans, spare parts, and other necessary equipment must be stored in tool boxes or other appropriate locations. Do not allow these items to lie around loose in operator cab or on steps, ladders, catwalks, and platforms.
- To reduce risk of slipping, non-skid material (sand in paint) has been applied to painted walkways and platforms.
- Walkways and platforms can be slippery when wet and when oil or grease is spilled on them. **Keep walkways and platforms clean and dry to prevent slipping on them.** When non-skid material wears out, reapply it.
- Wear shoes with a highly slip-resistant sole material. Clean any mud or debris from shoes before entering the crane cab or climbing onto the cab. A shoe that is not clean might slip off a control pedal during operation.
- Do not make modifications or additions to the crane's access system that have not been evaluated and approved by Maniowoc.

## GETTING ON OR OFF CRANE

Personnel getting on and off the crane shall do so only:

- a. at the steps or ladders provided,
- b. while crane is parked and not moving,
- c. with the operator's or qualified person's permission,
- d. if the performance of their duties requires them to do so.

When personnel use the steps and ladders to get on or off the crane, their hands shall be free of any objects. Objects which cannot be carried in pockets or tool belts shall be lifted into place with a hand line or hoist.

Always maintain a three-point contact with the ladder: two feet and one hand or two hands and one foot.

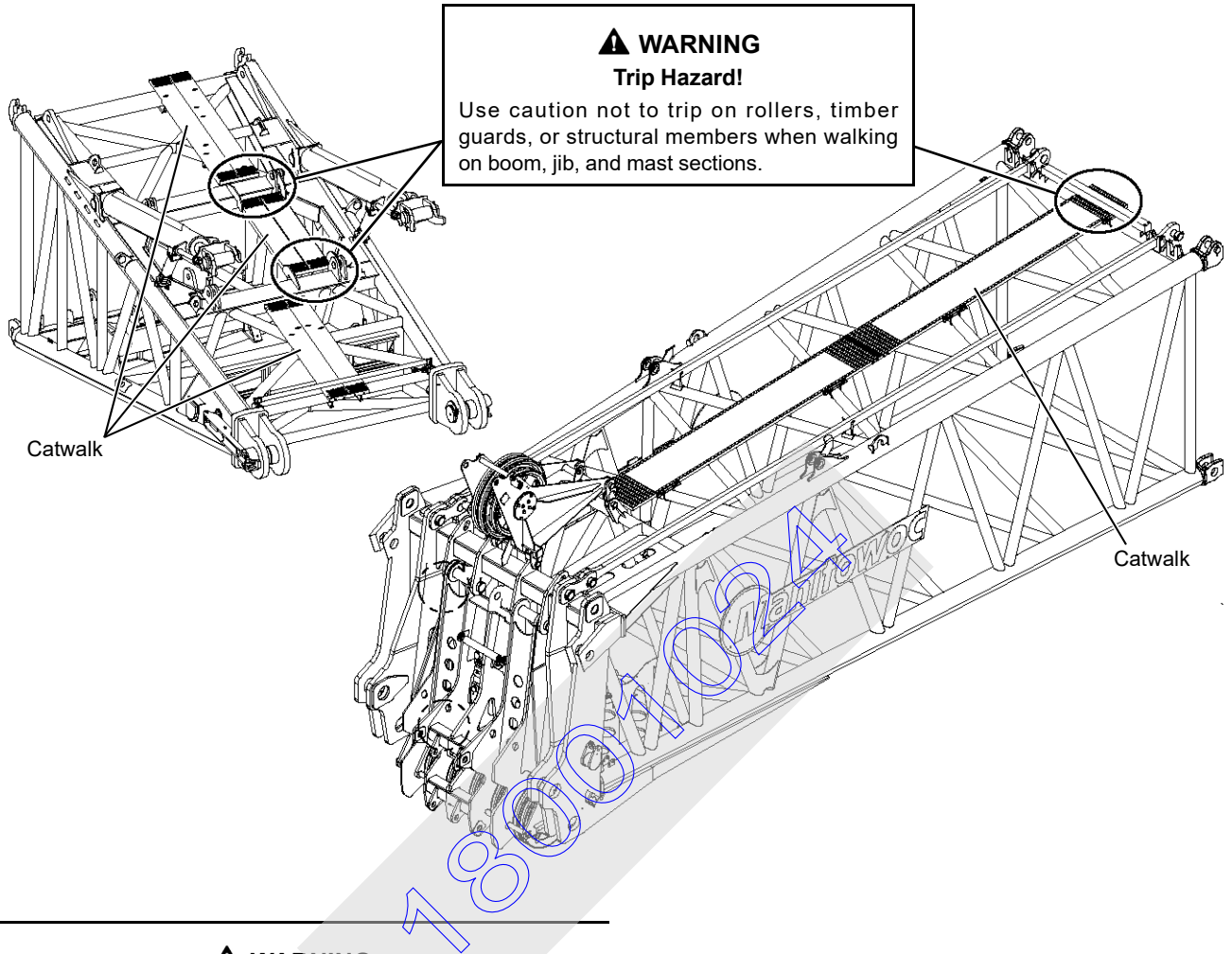

**▲ WARNING**  
**Trip Hazard!**  
Use caution not to trip on rollers, timber guards, or structural members when walking on boom, jib, and mast sections.

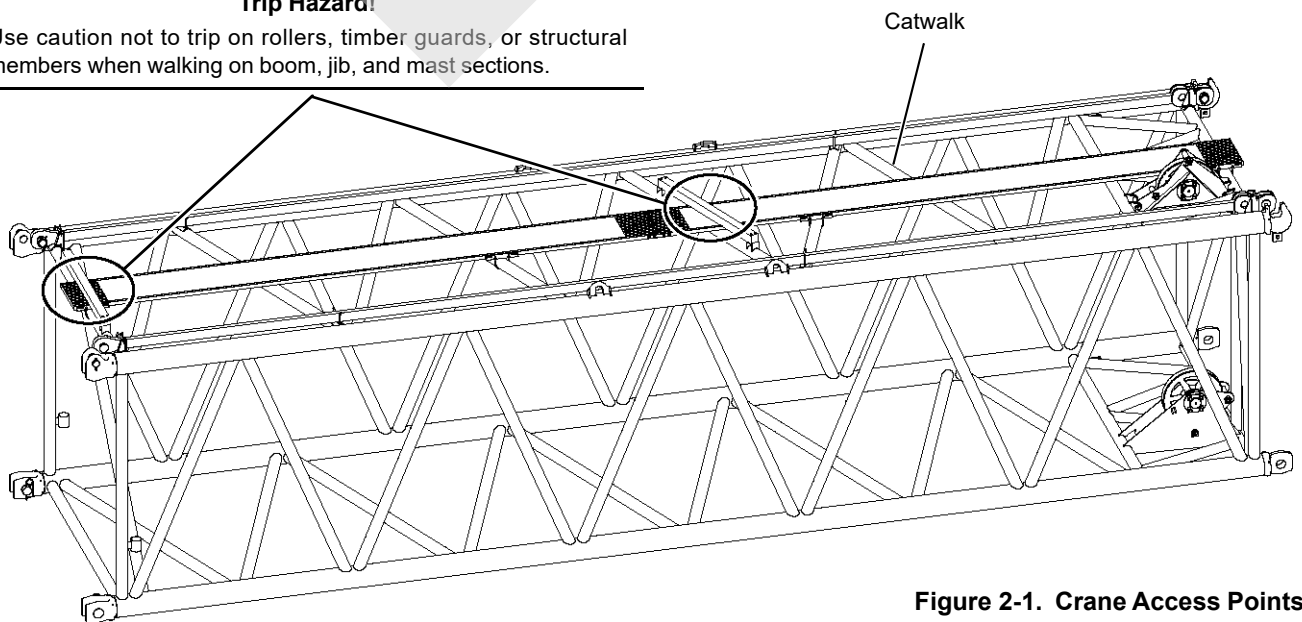
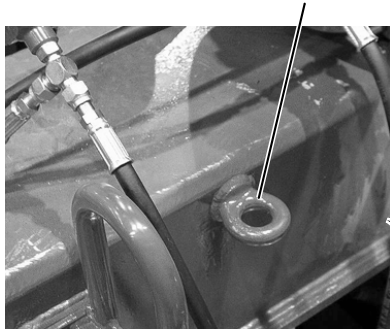

Figure 2-1. Crane Access Points

- Anchor for personnel fall-protection equipment:
- 4 Places Front of Rotating Bed
  - 3 Places on Engine Covers
  - 3 Places on Rear of Rotating Bed (under mast)
  - 2 Places Each Upper Counterweight Tray



P1951

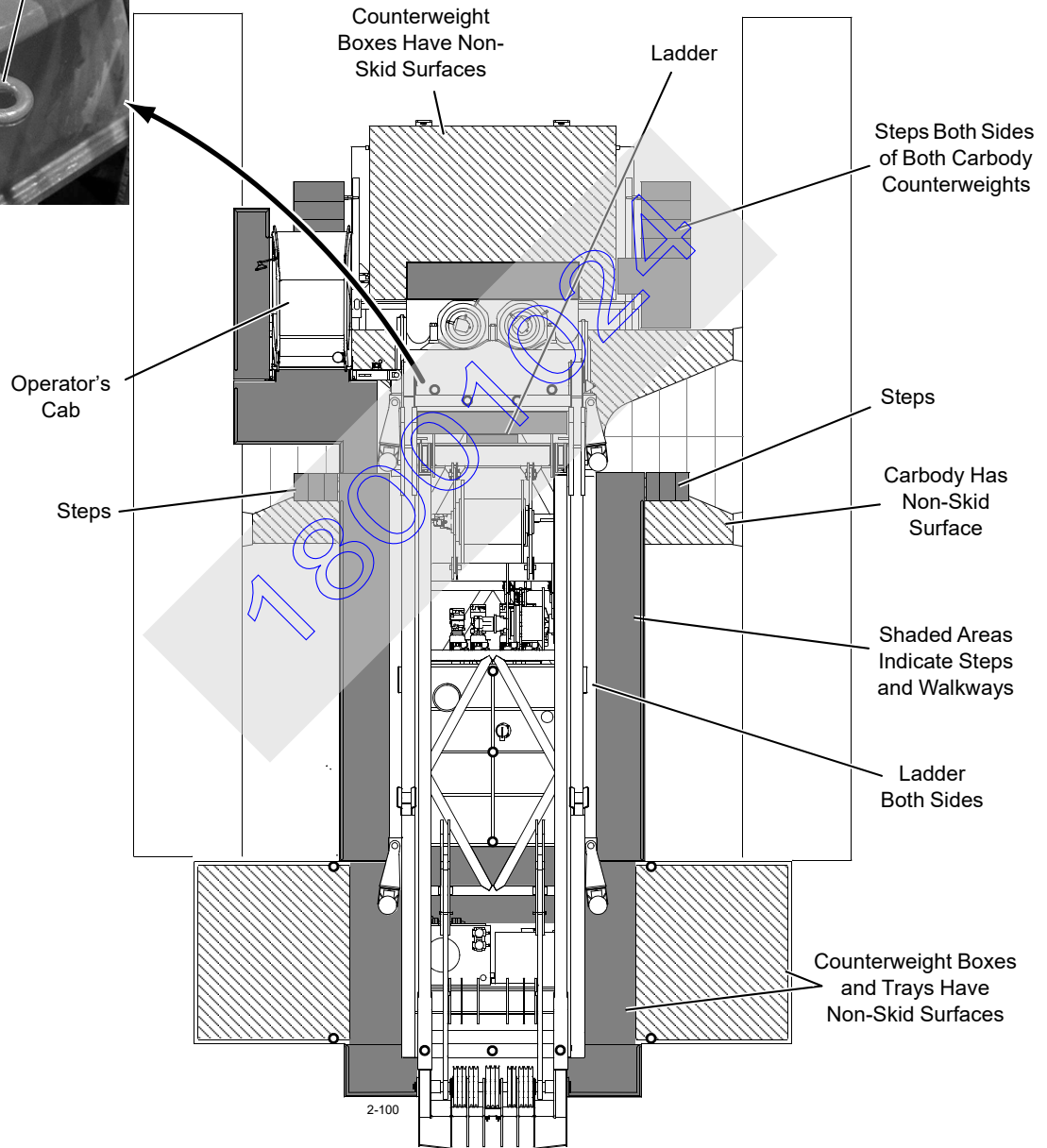

Figure 2-2. Crane Access Points



## PERSONAL FALL-PROTECTION

It is the crane owner/user's responsibility to provide assembly/maintenance personnel with appropriate fall-protection equipment.

### **WARNING** Fall Hazard!

To prevent falling from any height during crane assembly and disassembly, personnel shall appropriately wear fall-protection equipment.

## OPERATOR MANUAL/CAPACITY CHART STORAGE

### General

Manitowoc provides the following manuals and other important literature with your crane:

- Operator Manual (Serial Numbered)  
Contains safety information, crane specifications, assembly/erection procedures, operating instructions, lubrication and maintenance checks.
- Parts Manual (Serial Numbered)  
Contains illustrations and part numbers of replaceable parts.
- Capacity Chart Manual (Serial Numbered)  
Contains lifting capacities and related information (wire rope specifications, drum and lagging information, etc.)
- Maintenance Checks and Lube Guide  
Contains lists of maintenance checks and lube services and their prescribed intervals.
- RCI/RCL Operation  
Contains rated capacity indicator and/or rated capacity limiter operation, limits, and calibration procedures.
- Service Manual (Serial Numbered)  
Contains theory of operation, maintenance procedures, crane and wire rope inspection procedures, troubleshooting information, and shop procedures.

The manuals which must be retained in the operator cab (Operator Manual, Capacity Charts, Maintenance Checks and Lube Guide, and RCL Operation) are supplied in an OPERATOR INFORMATION binder.

The Operator Manuals and Capacity Charts are stamped with the serial number of the crane or attachment. The serial number on the manuals and capacity charts must match the serial number of the crane. **Using any other manual or capacity chart is prohibited.**

The crane model and serial number are located on the Crane Identification Plate on the crane cab.

If the serial numbers of your manuals and capacity charts do not match the serial numbers of the crane, contact your Manitowoc dealer for the proper manual or capacity charts.

**Do not operate the crane if the proper Capacity Chart is not in the cab.**

### Storing Manuals

See [Figure 2-3](#).

Store the Operator Information Manuals for the crane and each applicable attachment on the bookshelf in the Operator's cab.

Attach the chain from the manual in use to the link behind the operator's seat.

Keep all other manuals provided with the crane in the crane owner's/user's office so they are readily available when needed.

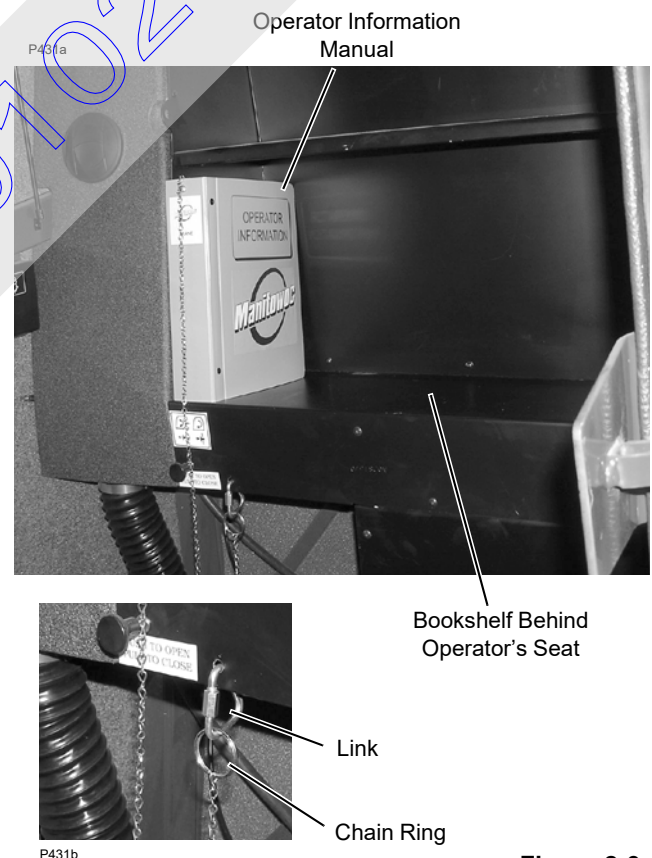

**Figure 2-3.**

## SAFE OPERATING PRACTICES

### General

The importance of safe operation cannot be over emphasized. Carelessness and neglect on the part of operators, supervisors and planners, rigging personnel and job site personnel can result in their death or injury and costly damage to the crane or property.

The safety information in this publication is intended only as a guide to assist qualified operators, supervisors and planners, rigging personnel, and job site personnel in safe operation. Manitowoc cannot foresee all hazards that will arise in the field; therefore, **safety remains responsibility of crane operators and owner.**

Local, state, and other governmental agencies may require stricter operating practices. When a conflict in practices exists, follow the strictest practice.

### Work Area Control

Personnel within the swing radius of the crane and fall zone of the crane's boom and/or load are subject to hazards if the crane is not operated per the requirements of the manufacturer and industry recognized safe operating practices.

To minimize the risk of harm, training of personnel on jobsite hazard recognition and prevention is required. Additionally, restricting access to the swing radius and fall zone during specific work conditions is required. The U.S. Department of Labor, Occupational Safety and Health Administration (OSHA) regulations for Construction provides requirements in 29CFR1926.1417 Operation, 29CFR1926.1424 Work area control, 29CFR1926.1425 Keeping clear of the load and 29CFR1926.1426 Free fall and controlled load lowering.

### Read Operator Manual

Safe and efficient assembly, disassembly, and operation of this crane requires that it be maintained in proper working order and that its operators and maintenance personnel be familiar with the crane's functions and capabilities.

The Operator Manual supplied with and considered part of your crane must be read and completely understood by each person responsible for assembly, disassembly, operation, and maintenance of the crane.

The Operator Manual must be read to personnel who cannot read or understand English or other language into which the manual is translated.

Because of a program of continuing improvement in product design, Manitowoc reserves the right to change the information and specifications contained in the Operator

Manual at any time without notice. If you have any questions regarding the crane or its Operator Manual, please contact your Manitowoc dealer or Manitowoc Product Support.

### Operator Qualifications

The crane must be operated only by the following **qualified** personnel:

1. Designated operators.
2. Trainees under direct supervision of a designated operator.
3. Supervisors, inspectors, and maintenance or test personnel when necessary in performance of their duties. Operation of the crane by these personnel shall be limited to the crane functions needed to perform the inspection or to verify the crane's performance after maintenance procedures.

**No personnel shall be allowed to climb onto the crane or enter cab unless performance of their duties requires them to do so, and then only with knowledge of operator or other qualified person.**

**Qualified person** is defined as one who by reason of training and experience is thoroughly familiar with crane operations and the hazards involved. Such a person shall meet the operator qualifications specified in Occupational Safety and Health Administration (OSHA) Regulations (United States Federal Law), in ASME B30.5 American National Standard, or in any other applicable federal, state, or local laws.

**Operator training and qualification is crane owner's responsibility.**

**NOTE** The regulations and standards mentioned above and later in this section can be obtained from:

**US DOL/OSHA** Rules and Regulations are available by mail from the Superintendent of Documents, PO Box 371954, Pittsburgh, PA, 15250-7954 or by:

- Phone 202-512-1899
- Fax 202-512-2250
- Online at [www.osha.gov](http://www.osha.gov)

**ASME** (formerly ANSI) B30 Series American National Standards are available by mail from the ASME, 22 Law Drive, Fairfield, New Jersey, 07004-2900 or by:

- Phone US & Canada 800-843-2763
- Phone Mexico 95-800-843-2763
- Phone Universal 973-882-1167
- Fax 973-882-1717 or 973-882-5155



- E-mail [infocentral@asme.org](mailto:infocentral@asme.org)

## Operator Conduct

1. The operator shall not engage in any practice which diverts his/her attention while operating the crane.
2. The operator shall not operate the crane when he/she is physically or mentally unfit.
3. The operator shall be responsible for all operations under his/her direct control. When safety of an operation is in doubt, the operator shall stop the crane's functions in a controlled manner. Lift operations can resume only after safety concerns have been addressed or the continuation of crane operations is directed by the lift supervisor.
4. The operator shall be thoroughly familiar with operation of the crane and its proper care. If adjustments or repairs are necessary or if there are known defects that impair safe operation, the crane must not be operated until unsafe conditions have been corrected.
5. If there is a warning sign at the start controls, the operator shall not start the engine until the warning sign has been removed by the person who installed it.
6. Before starting the engine, the operator shall make sure that:
  - a. All daily inspection and maintenance services have been performed.
  - b. All controls are in the off position and all brakes and locking devices are applied or engaged.
  - c. All personnel are clear of the crane. Deploy a swing radius barrier.
7. The operator shall test all controls, limits, and communication systems at the start of each shift. Any defects found must be corrected before operation is begun.
8. The operator shall not start crane movement if the load or designated signal person is not within his/her range of vision or communication.
9. The operator shall understand and respond to signals from the person directing the lift or from the designated signal person. When a signal person or crane follower is not required, the operator is responsible for the lift. **Operator shall obey a stop signal at all times, no matter who gives it.**
10. The operator shall verify that the Capacity Chart being used is the correct one for the cranes configuration (boom length, load line reeving, counterweight, etc.).
11. The operator shall verify that:
  - a. All attachments are properly assembled and attached to the crane according to the rigging drawings called for in the Capacity Chart.
  - b. The counterweight — to include applicable auxiliary counterweight — is in place and of proper weight. **Maximum required counterweight must not be exceeded.**

### WARNING

Safety devices and operational aids such as rated capacity indicator or limiter, boom and jib angle indicator or limiter, anti-two-block device, level indicator, swing limiter, proximity device, etc., may be installed on your crane. Such devices are to be used only as **AIDS TO ASSIST OPERATOR**; their presence on the crane in no way substitutes for or lessens requirement that operator knowledge, experience, and judgment are required to ensure safe operation of the crane.

**Crane must not be loaded beyond applicable static or dynamic ratings given in Capacity Chart for crane.**

- See Size of Load later in this section.
- For a description of each safety device and operational aid, see Section 3 of the MLC100-1 Operator Manual.

### WARNING

#### Moving Load/Tipping Crane Hazard!

Changing weather conditions including, but not limited to: wind, ice or snow accumulation, precipitation, flooding, lightning, etc. should be considered when determining the location and configuration of a crane when it will be left unattended.

12. The operator shall perform the following operations before leaving the operator cab for any reason:
  - a. Park the crane and position upperworks so the crane does not interfere with operation of other equipment.
  - b. Apply travel and swing brakes or locking devices.
  - c. Land any attached load.
  - d. Lower the boom onto blocking at ground level or onto a boom rest if possible.
 

If the boom cannot be lowered, as determined by a qualified designated person, it must be securely fastened from movement by wind or other outside forces (see Wind Conditions in Capacity Chart Manual).

**NOTE** The designated person shall be familiar with the job site limitations, the crane configuration, and the expected weather conditions.

- e. Move all controls to off.
- f. Apply all drum brakes and pawls.
- g. Disengage the master clutch, if equipped.
- h. Stop the engine.

**NOTE** Also read Unattended Crane instructions in Section 3 of the Crane Operator Manual.

**13.** The operator shall perform the following operations if power or a control function fails during operation:

- a. Land all suspended loads, if possible, under brake or power control.
- b. Apply all brakes and locking devices.
- c. Move all controls to off.

**14.** If the crane will be operated at night, the operator shall make sure that there is sufficient lighting for safe operation. The load and landing area must be illuminated.

**15.** The operator shall not operate the crane during periods of bad weather if his/her ability to see the load or the signal person is impaired by darkness, fog, rain, snow, and the like.

Do not operate the crane with a snow or ice covered boom. The extra weight may cause overload, tipping, or structural damage.

Never operate the crane during an electrical thunderstorm.

When a local weather storm warning exists (including electrical thunderstorm), stop operation and secure the crane. See step [12](#) on [page 2-9](#).

**NOTE** DO NOT depend on grounding. Grounding of a crane affords little or no protection from electrical hazards. The effectiveness of grounding is limited by the size of the conductor (wire) used, condition of the ground, the magnitude of voltage and current present, and numerous other factors.

**16.** Wind can cause the crane to tip or the boom and other attachments to collapse. The operator or qualified person directing the lift shall compensate for the effect of wind on the load and boom by reducing ratings, reducing operating speeds, or a combination of both.

Unless otherwise specified in the Capacity Chart, or Operator Manual, stop operation under the following wind conditions:

- a. If the wind causes the load to swing forward past the allowable operating radius or sideways past either

boom hinge pin, land the load and apply the drum brakes.

- b. If the wind exceeds 16 m/s (35 mph), land all loads and apply the drum brakes, lower the boom onto blocking at ground level or otherwise restrain it, and apply the swing and travel brakes and/or locks.

**NOTE** “*Land load*” means to set it down on a firm uniformly supporting surface.

**17.** Booms, jibs, or masts which are being assembled or disassembled on the ground (with or without support of boom rigging) must be securely blocked to prevent the boom, jib, or mast sections from dropping.

**Workers shall not go under boom, jib, or mast sections when removing connecting pins or bolts.**

**18.** Each outrigger must be visible to the operator or the signal person during extension and retraction.

## Handling Load

### Size of Load

1. The crane must not be loaded beyond the applicable static or dynamic ratings given in the Capacity Chart for the crane configuration.
2. The ratings given in the Capacity Chart are developed based on “Freely suspended loads” and specified operating conditions. When cranes are used for service other than lifting service and/or special lifting operations, Manitowoc or a qualified person shall establish the ratings, operating limitations, maintenance, testing, and inspection requirements. Please reference Special Application/Service later in this section.

**NOTE** “*Freely suspended load*” is a load that is hanging free with no direct external force applied except by the crane’s load-line reeving.

To determine the actual weight of the load which can be lifted at a given radius (working load), the operator shall deduct the weight of certain lifting equipment from the total weight given in the chart. See the specific Capacity Chart for your crane for a list of lifting equipment which must be deducted.

The operator’s judgment shall be used to further reduce total load to allow for the dynamic effects of swinging, hoisting, or lowering, and adverse weather conditions to include wind.

3. The operator or other designated person directing the lift shall verify that the weight of load is within the static or dynamic rating for radius at which load will be lifted.

**Verified weights and measured radii must take priority over RCI/RCL readings.**

### Attaching Load

1. Attach the hook to the load with slings, or other suitable rigging. Each hook must have a latch that is in proper working order. **Hook latches must not be wired open.**
  - a. Inspect each hook and latch before using.
  - b. Never use a hook or latch that is distorted or bent.
  - c. Make sure spring will force the latch against the tip of the hook.
  - d. Make sure the hook supports the load. The latch must never support the load. Latches are only intended to retain loose slings under slack conditions.
2. Only use slings and other rigging that are in safe operating condition and have a rating equal to or greater than the load to be lifted.
3. Do not wrap the load line around the load.
4. Use suitable protection between slings and any sharp edges on the load. When synthetic slings are used, the synthetic sling manufacturer's instructions, limitations, specifications, and recommendations must be followed.
5. Secure unused legs of a multi-leg sling before handling a load with one leg of sling.

### Lifting/Moving Load

1. Before lifting or moving a load, the operator or qualified person directing the lift shall make the following checks.
  - a. Crane has a firm, uniformly supporting foundation under all crawlers. Unless otherwise specified in the Capacity Chart, the foundation must be level to within 1% — 0,3 m (1ft) rise or fall in 30,3 m (100 ft) distance.
 

When such a surface is not available, it must be provided with timbers, cribbing, or other structural members to distribute the load such that the allowable bearing capacity of the underlying member is not exceeded.

For ground bearing data go to: [www.manitowoc.com](http://www.manitowoc.com)
  - b. The load is secured and properly balanced in the slings or the lifting device before lifting the load more than 76 to 152 mm (3 to 6 in).
  - c. The lift and swing paths are clear of personnel and obstructions.
  - d. The load is free to be lifted.
  - e. The load line is not kinked or otherwise damaged.
  - f. Multiple part load lines are not twisted around each other in such a manner that the lines will not separate when the load is lifted.

- g. The hook is brought over the load in a manner that will minimize twisting or swinging.
  - h. The load line and the boom hoist rope are properly spooled on the drums and seated in the sheaves.
  - i. The load drum brakes are in proper working order.
 

The operator shall test the load drum brakes each time a load approaching the rated load is handled. Lift the load 76 to 152 mm (3 to 6 in) and fully apply the brakes — load must not lower through applied brakes.
  - j. Unused load drums are parked (working and parking brakes applied; if equipped, drum pawls engaged).
  - k. All personnel are clear of the swing radius of the crane's counterweight.
2. While lifting or moving the load, the operator shall take the following precautions:
    - a. Accelerate and decelerate the load smoothly to avoid excessive stress on the boom and machinery.
    - b. Avoid sudden starts and stops while swinging. Keep the swing speed under control to prevent the load from swinging out beyond the radius at which the load can be handled and to minimize the pendulum action of the load.
    - c. When lifting, any non-vertical loads applied to the crane from dynamics, multi-crane lifts or environmental factors must be minimized or eliminated. The load must remain under the lifting point at all times.
    - d. Sound the signal horn before swinging and intermittently while swinging, especially when approaching personnel.
 

If equipped, the automatic swing alarm will sound when the crane is swung.
    - e. Use taglines or other restraints to control the load when necessary.
    - f. Do not exceed any swing limitations (areas of operation) given in the Capacity Chart.
    - g. Do not allow the load, boom, or any other part of the crane to contact obstructions.
    - h. Do not use the crane to drag a load.
    - i. Do not hoist, lower, or swing the load while personnel are on the load or the hook. See Personnel Handling in this section.
    - j. Avoid carrying the load over personnel. Loads which are suspended must be blocked or cribbed before personnel are allowed to work under or between them.

- k. Before lifting a load which requires the use of outriggers (or anytime outriggers are used), fully extend the outrigger beams and jacks so the truck tires do not bear any load.

Securely fasten the outrigger jack pads or floats to jacks and set them on a flat, firm surface that will support the load placed on the pads or floats. Do not set the jack pads or floats in holes, on rocky ground, or on extremely soft ground.

When dictated by ground conditions, install wood blocking or steel plates under the jack pads or floats to properly distribute the loading on the supporting surface.

Wood blocking or steel plates used under the jack pads or floats must be:

- Free of defects
- Strong enough to prevent crushing, bending, or shear failure
- Of sufficient thickness, width, and length to completely support the jack pad or float, transmit the load to the supporting surface, and prevent shifting, toppling, or excessive settlement under load.

- l. Fully retract and lock the jacks and the outrigger beams so they cannot extend when not in use.

- m. Do not lower the load or the boom to a point where less than three full wraps of wire rope remain on the respective drum (or as otherwise indicated in local, state, or federal regulations).

- n. Engage the boom hoist pawl when operating with the boom at a fixed radius.

- o. Engage the luffing hoist pawl when operating with the luffing jib at a fixed radius.

- 3. While traveling, the operator shall take the following precautions:

- a. Sound the signal horn before traveling and intermittently while traveling, especially when approaching personnel.

If equipped, the automatic travel alarm will sound when the crane is traveled.

- b. Carry the boom in-line with the lowerworks and facing the direction of travel.

- c. Do not position the boom so high that it could bounce over backwards whether traveling with or without load.

- d. Secure the rotating bed against rotation except when it is necessary to negotiate a turn, and then only when the operator is seated at controls or the boom is supported on a dolly.

- e. Lash or otherwise restrain unused hooks so they cannot swing freely.

- 4. Before traveling with a load, the operator shall take the following additional precautions:

- a. A designated person shall be responsible for operation. Decisions such as the necessity to reduce crane ratings, load position, boom position, ground support, and speed of movements must be in accordance with the designated person's decision.

- b. Maintain specified tire pressures (truck cranes).

- c. Avoid sudden starts and stops. Use taglines or other restraints to control the position of the load.

### **Holding Load**

When a load is suspended, the operator shall take the following precautions:

1. Not leave his/her position at the controls
2. Not allow personnel to stand or pass under the load
3. Move all controls to off, apply all drum brakes, engage the boom hoist pawl, and apply the swing and travel brakes or locks.

### **SIGNALS**

1. Continuous communication must be maintained between the operator and the signal person during all crane movements. If communication is disrupted, **operator shall stop all crane movements.**

2. Signals to the operator must be in accordance with the standard signals shown in Section 3, unless communications equipment (telephone, radio, etc.) is used.

3. All signals must be easily understood by the operator at all times. The operator shall not respond to any signal which is not clearly understood.

4. For operations not covered in the standard signals, or for special situations or emergencies, additional signals may be required. In those cases, the signals used must be agreed upon in advance by the operator and the signal person. The signals used must not conflict with or have potential to be confused with the standard signals.

5. When it is necessary to give instructions to the operator (other than those established by the signal system), all crane motions must be stopped.

6. The signal person shall:

- a. Be tested by a designated person and show that he or she has a basic understanding of crane operations and limitations, to include boom deflection.

- b. Be thoroughly familiar with the standard hand signals and voice signals if used.
  - c. Be positioned in clear view of the operator. The signal person's position should give him or her a clear view of the load, the crane, and the operating area.
  - d. Direct the load so it does not pass over personnel.
  - e. Keep unnecessary personnel out of the crane's operating area.
7. When moving the crane, the following audible signals must be used:
- a. STOP - one short audible signal
  - b. GO AHEAD - two short audible signals
  - c. BACK UP - three short audible signals
3. Cranes operating on a barge require: a trim indicator, a swing brake, and a wind direction indicator if the wind is a factor (supplied by crane owner or user).
  4. Boom stops, both physical and automatic  
If a boom stop is damaged or not working properly, it must be tagged-out or removed if possible.
  5. Jib stops, both physical and automatic (for fixed jib and luffing jib)  
If a jib stop is damaged or not working properly, it must be tagged-out or removed if possible.
  6. Pedal locks for all foot-operated brakes (if applicable)  
If a pedal lock is damaged or not working properly, it must be tagged-out or removed if possible.
  7. An integral holding device or check valve on each jacking cylinder.

## SAFETY DEVICES



### WARNING

Do not operate the crane unless all safety devices listed in this section are in proper working order.

- If a safety device stops working properly during operation, the operator shall safely stop operation.
- If any safety device listed in this section is not in proper working order, the safety device must be taken out of service and crane operation must not resume until the safety device is again working properly.
- Alternative measures are not permitted to be used for a faulty safety device.
- Always tag-out any faulty safety device and place a warning tag in the cab stating that the crane is out of service and must not be used.

Manitowoc provides the following safety devices on its cranes.

1. Horn activated by a switch on the control console in the operator cab  
If the horn is not working properly, it must be tagged-out or removed if possible.
2. Crane level indicator: either electronic (viewable in crane's electronic display) or mechanical (viewable from operator cab seat). If the crane level indicator is not working properly, it must be tagged-out or removed, if possible.

## OPERATIONAL AIDS



### WARNING

Do not operate the crane unless all applicable operational aids listed in this section are in proper working order, except:

- Where an operational aid is being repaired
- The crane user implements a specified temporary alternative measure.

If an operational aid stops working properly during operation, the operator shall safely stop operation until the temporary alternative measures are implemented or the device is again working properly.

Manitowoc provides the following operational aids on its cranes, either as standard equipment or optional equipment. The operational aids are designated as Category 1 or Category 2:

### Category 1 Operational Aids

If a Category 1 operational aid is not working properly, it must be repaired no later than 7 calendar days after the deficiency occurs.

Exception: If the crane user documents that he/she has ordered the necessary parts within 7 calendar days of the occurrence of the deficiency, the repair must be completed within 7 calendar days of receiving the parts.



### 1. Boom or Luffing Jib Angle Limiter

(automatic boom or jib stop)

Temporary alternative measures if inoperative or malfunctioning:

The qualified person directing the lift shall make sure the maximum boom or jib angle/radius specified in the Capacity Chart for the load being handled is not exceeded. One or more of the following methods must be used:

- a. Measure radius using a tape measure.
- b. Measure the boom angle with a protractor-level on the centerline of boom.
- c. Clearly mark the boom or luffing hoist cable (so it can easily be seen by the operator) at a point that gives the operator sufficient time to stop the boom or jib within the minimum allowable radius.

In addition, install mirrors or remote video cameras and displays if necessary for the operator to see the mark.

- d. Clearly mark the boom or luffing hoist cable (so it can easily be seen by a designated signal person) at a point that gives the signal person sufficient time to signal the operator and have the operator stop the boom or jib within the minimum allowable radius.

### 2. Anti-Two-Block Device

Temporary alternative measures if inoperative or malfunctioning:

The qualified person directing the lift shall establish procedures to furnish equivalent protection. One or more of the following methods must be used:

- a. Assign a signal person to signal the operator to stop hoisting when the load is a safe distance from the boom or jib point.
- b. Clearly mark the hoist cable (so it can easily be seen by the operator) at a point that will give the operator sufficient time to stop the load a safe distance from the boom or jib point.

The temporary alternative measures for the anti-two-block device do not apply when lifting personnel in load line supported baskets.

**Personnel shall not be lifted in load line supported baskets when anti-two-block devices are not functioning properly.**

## Category 2 Operational Aids

If a Category 2 operational aid is not working properly, it must be repaired no later than 30 calendar days after the deficiency occurs.

Exception: If the employer documents that he/she has ordered the necessary parts within 7 calendar days of the occurrence of the deficiency, and the part is not received in time to complete the repair in 30 calendar days, the repair must be completed within 7 calendar days of receiving the parts.

### 1. Rated Capacity Indicator/Limiter

Temporary alternative measures if inoperative or malfunctioning:

The qualified person directing the lift shall establish procedures for determining load weights and shall make sure that the weight of the load does not exceed the crane's rating at the radius where the load is handled.

The weight of the load must be provided to the operator before the lift is made.

### 2. Boom Angle or Radius Indicator

Temporary alternative measures if inoperative or malfunctioning:

- a. Refer to the pendulum boom angle indicator on the boom butt (visible from operator cab).
- b. Measure the boom angle with a protractor-level on the centerline of boom.
- c. Measure radius using a tape measure.

### 3. Jib Angle or Radius Indicator

Temporary alternative measures if inoperative or malfunctioning. Use either or both:

- a. First, make sure you know the boom angle (see item [2](#) above).
- b. Then, measure radius using a tape measure.

### 4. Drum Rotation Indicator

Temporary alternative measures if inoperative or malfunctioning:

Mark the drum to indicate its rotation.

If the operator cannot see the drum, add mirrors or remote video cameras and displays so the operator can see the mark.

### 5. OPTIONAL Swing Limiter or Proximity Device

Temporary alternative measures if inoperative or malfunctioning:

The qualified person directing the lift shall establish procedures to furnish equivalent protection (for example, assign an additional signal person to observe the distance between the boom or load and job site obstructions to include power lines or to limit the swing sector specified in the Capacity Chart).

## 6. OPTIONAL Drum Spooling Limiter (maximum or minimum bail limit)

Temporary alternative measures if inoperative or malfunctioning:

The qualified person directing the lift, the operator, or a designated signal person shall watch the drum and signal the operator to stop it before it is over spooled (rope does not jump off drum) or before there are less than 3 full wraps of wire rope on the load drum or boom hoist.

## 7. OPTIONAL Closed-Circuit Television (CCTV)

Temporary alternative measures if inoperative or malfunctioning:

A designated signal person shall watch the load, the drums, and the counterweight and provide necessary hand or voice signals to the crane operator.

## ASSEMBLING, DISASSEMBLING, OR OPERATING CRANE NEAR ELECTRIC POWER AND TRANSMISSION LINES

### Electrocution Hazard

Thoroughly read, understand, and abide by all applicable federal, state, and local regulations regarding operation of cranes near electric power lines or equipment.

***United States federal law prohibits the use of cranes closer than 6 m (20 ft) to power sources up to 350 kV and greater distances for higher voltages unless the line's voltage is known [29CFR1910.180 and 29CFR1926.1400]***

***To avoid death or serious injury, Manitowoc recommends that all parts of the crane, boom, and load be kept at least 6 m (20 ft) away from all electrical power lines and equipment less than 350 kV.***

**NOTE** For detailed guidelines on operating near power lines, refer to the current edition of OSHA 29CFR1926.1400 and ASME B30.5 American National Standard.



### WARNING

#### Electrocution Hazard!

Manitowoc cranes are not equipped with all features required to operate within OSHA 29CFR1926.1408, Table A clearances when the power lines are energized.

1. Keep all personnel and their personal belongings (clothing, water coolers, lunch boxes, etc.) away from

the crane if it is being operated near electrical power lines or equipment.

2. Before operating the crane in the vicinity of electrical power lines or equipment, notify the power utility company. Obtain positive and absolute assurance that the power has been turned off.

The crane is NOT INSULATED. Always consider all parts of the load and the crane as conductors, including the wire rope, pendants or straps, and taglines.

Most overhead power lines ARE NOT insulated. Treat all overhead power lines as being energized unless you have reliable information to the contrary from the utility company or owner.

The rules in this section must be followed at all times, even if the electrical power lines or equipment have been de-energized.

3. Crane operation is dangerous when close to an energized electrical power source. Exercise extreme caution and prudent judgment. Operate slowly and cautiously when in the vicinity of power lines.
4. If the load, wire rope, boom, or any portion of the crane contacts or comes too close to an electrical power source, everyone in, on, and around the crane can be seriously injured or killed.

The safest way to avoid electrocution is to stay away from electrical power lines and electrical power sources.

5. The operator is responsible for alerting all personnel to the dangers associated with electrical power lines and equipment. The crane is not insulated. Do not allow unnecessary personnel in the vicinity of the crane while operating. Permit no one to lean against or touch the crane. Permit no one, including riggers and load handlers, to hold the load, load lines, taglines, or rigging gear.
6. Even if the crane operator is not affected by an electrical contact, others in the area may become seriously injured or killed.
7. It is not always necessary to contact a power line or power source to become electrocuted. Electricity, depending on magnitude, can arc or jump to any part of the load, load line, or crane boom if it comes too close to an electrical power source. Low voltages can also be dangerous.

### Set-Up and Operation

1. During crane use, assume that every line is energized ("hot" or "live") and take necessary precautions.
2. Position the crane such that the load, boom, or any part of the crane and its attachments cannot be moved to within 6 m (20 ft) of electrical power lines or equipment.

This includes the crane boom and all attachments. Overhead lines tend to blow in the wind, so allow for movement of the overhead lines when determining a safe operating distance.

3. Erect a suitable barricade to physically restrain the crane, all attachments, and the load from entering into an unsafe distance from electrical power lines or equipment.
4. Plan ahead and always plan a safe route before traveling under power lines. A wooden clearance frame should be constructed to ensure sufficient clearance is maintained between crane and power lines.
5. Appoint a reliable and qualified signal person, equipped with a loud signal whistle or horn and voice communication equipment, to warn the operator when any part of the crane or load moves near a power source. This person should have no other duties while the crane is working.
6. Taglines should always be made of non-conductive materials. Any tagline that is wet or dirty can conduct electricity.
7. DO NOT store materials under power lines or close to electrical power sources.
8. When operating near transmitter/communication towers where an electrical charge can be induced into the crane or load:
  - The transmitter must be deenergized OR,
  - Tests must be made to determine if an electrical charge will be induced into the crane or load.
  - The crane must be provided an electrical ground.
  - If taglines are used, they must be non-conductive.
  - Every precaution must be taken to dissipate induced voltages. Consult with a qualified RF (radio frequency) Consultant. Also refer to local, state, and federal codes and regulations.

## Electrical Contact

If the crane comes in contact with an energized power source, the operator shall:

1. Stay in the crane cab. DON'T PANIC.
2. Immediately warn PERSONNEL in the vicinity to STAY AWAY.
3. Attempt to move the crane away from the contacted power source using the crane's controls which are likely to remain functional.
4. Stay in the crane until the power company has been contacted and the power source has been de-energized.

NO ONE shall attempt to come close to the crane or load until the power has been turned off.

Only as a last resort should an operator attempt to leave the crane upon contacting a power source. If it is absolutely necessary to leave the cab, JUMP COMPLETELY CLEAR OF CRANE. DO NOT STEP OFF. Hop away with both feet together. DO NOT walk or run.

5. Following any contact with an energized electrical source, your Manitowoc dealer shall be immediately advised of the incident and consulted on necessary inspections and repairs.

If the dealer is not immediately available, contact Manitowoc Product Support. The crane must not be returned to service until it is thoroughly inspected for any evidence of damage and all damaged parts are repaired or replaced as authorized by Manitowoc or your Manitowoc dealer.

## REFUELING

1. When using a portable container to refuel the crane, the container must be a safety-type can equipped with an automatic closing cap and a flame arrester.
2. The engine must be **stopped** before refueling the crane.
3. Smoking and open flames must be prohibited in refueling area.

## FIRE EXTINGUISHERS

1. A portable fire extinguisher with a minimum rating of 10 BC must be installed in operator's or machinery cab of the crane.
2. The operator and all maintenance personnel shall be thoroughly familiar with the location, use, and care of the fire extinguisher(s) provided.

## ACCIDENTS

If this crane becomes involved in a property damage and/or personal injury accident, immediately contact your Manitowoc dealer or the Product Safety and Reliability Department at the following address:

**Manitowoc Cranes**  
2401 So. 30th St.  
Manitowoc, WI 54220

Phone: 920-684-6621

Provide a complete description of the accident, including the crane model and serial number. Accident reporting forms can be found at [www.manitowoc.com](http://www.manitowoc.com).

The crane must not be returned to service until it is thoroughly inspected for any evidence of damage. All



damaged parts must be repaired or replaced as authorized by Manitowoc.

## SAFE MAINTENANCE



### WARNING

Importance of safe maintenance cannot be over emphasized. Carelessness and neglect on part of maintenance personnel can result in their death or injury and costly damage to the crane or property.

Safety information in this publication is intended only as a guide to assist qualified maintenance personnel in safe maintenance. Manitowoc cannot foresee all hazards that will arise in field; therefore, **safety remains responsibility of maintenance personnel and crane owner.**

## Maintenance Instructions

To ensure safe and proper operation of Manitowoc cranes, they must be maintained according to the instructions contained in this manual and in the Service Manual provided with the crane.

Crane maintenance and repair must be performed by qualified personnel. These personnel shall **read Operator Manual and Service Manual before attempting any maintenance procedure.** If there is any question regarding maintenance procedures or specifications, contact your Manitowoc dealer for assistance.

**Qualified person** is defined as one who by reason of training and experience is thoroughly familiar with the crane's operation and required maintenance as well as the hazards involved in performing these tasks.

**Training and qualification of maintenance and repair personnel are crane owner's responsibility.**

## Safe Maintenance Practices

1. Perform the following steps (as applicable) before starting a maintenance procedure:
    - a. Park the crane where it will not interfere with other equipment or operations.
    - b. Lower all loads to the ground or otherwise secure them against movement.
    - c. Lower the boom onto blocking at ground level, if possible, or otherwise secure the boom against dropping.
    - d. Move all controls to off and secure all functions against movement by applying or engaging all brakes, pawls, or other locking devices.
  - e. Stop the engine and render the starting means inoperative.
  - f. Place a warning sign at the start controls alerting other personnel that the crane is being serviced and the engine must not be started. **Do not remove sign until it is safe to return the crane to service.**
2. Do not attempt to maintain or repair any part of the crane while the engine is running, unless absolutely necessary.
 

If the engine must be run, keep your clothing and all parts of your body away from moving parts. **Maintain constant verbal communication between person at controls and person performing maintenance or repair procedure.**
  3. Wear clothing that is relatively tight and belted.
  4. Wear appropriate eye protection and approved hard hat.
  5. Never climb onto or off a moving crane. **Climb onto and off the crane only when it is parked and only with operator's permission.**

Use both hands and handrails, steps and ladders provided to climb onto and off the crane.

Lift tools and other equipment which cannot be carried in pockets or tool belts onto and off the crane with hand lines or hoists.
  6. The boom and gantry are not intended as ladders. Do not attempt to climb lattice work of the boom or gantry to get to maintenance points. If the boom or gantry is not equipped with an approved ladder, lower them before performing maintenance or repair procedures.
  7. Do not remove cylinders until the working unit has been securely restrained against movement.
  8. Pinch points are impossible to eliminate; watch for them closely.
  9. Pressurized air, coolant, and hydraulic oil can cause serious injury. Make sure all air, coolant, and hydraulic lines, fittings, and components are tight and serviceable.
 

**Do not use your hands to check for air, coolant or hydraulic oil leaks:**

    - Use a soap and water solution to check for air leaks (apply to fittings and lines and watch for bubbles).
    - Use a piece of cardboard or wood to check for coolant and hydraulic oil leaks.
  10. Relieve pressure before disconnecting air, coolant, and hydraulic lines and fittings.
  11. Do not remove the radiator cap while the coolant is hot or under pressure. Stop the engine, wait until the pressure drops and the coolant cools, then slowly remove the cap.

12. Avoid battery explosion: do not smoke while performing battery maintenance or short across battery terminals to check its charge.
13. Read the safety information in the battery manufacturer's instructions before attempting to charge a battery.
14. Avoid battery acid contact with skin and eyes. If contact occurs, flush the area with water and immediately consult a doctor.
15. Stop the engine before refueling the crane.
16. Do not smoke or allow open flames in refueling area.
17. Use a safety-type can with an automatic closing cap and flame arrestor for refueling.
18. Hydraulic oil can also be flammable. Do not smoke or allow open flames in the area when filling hydraulic tanks.
19. Never handle wire rope with bare hands. Always wear heavy-duty gloves to prevent being cut by broken wires.
20. Use extreme care when handling coiled pendants. Stored energy can cause the coiled pendants to uncoil quickly with considerable force.
21. When inflating tires, use a tire cage, a clip-on inflater, and an extension hose which permits standing well away from the tire.
22. Only use cleaning solvents which are non-volatile and non-flammable.
23. Do not attempt to lift heavy components by hand. Use a hoist, jacks, or blocking to lift components.
24. Use care while welding or burning on the crane. Cover all hoses and components with non-flammable shields or blankets to prevent a fire or other damage.
25. To prevent damage to crane parts (bearings, cylinders, swivels, slewing ring, computers, etc.), perform the following steps **before welding on the crane**:
  - Disconnect all cables from batteries.
  - Disconnect output cables at engine junction box.
  - Attach the ground cable from the welder directly to the part being welded and as close to the weld as possible.

Do not weld on the engine or engine mounted parts (per engine manufacturer).
26. Disconnect and lock the power supply switch before attempting to service high voltage electrical components and before entering tight areas (such as carbody openings) containing high voltage components.
27. When assembling and disassembling booms, jibs, or masts on the ground (with or without support of boom rigging pendants or straps), securely block each section to provide adequate support and alignment.
 

**Do not go under boom, jib, or mast sections while connecting bolts or pins are being removed.**
28. Unless authorized in writing by Manitowoc, do not alter the crane in any way that affects the crane's performance (including welding, cutting, or burning of structural members or changing pressures and flows of air/hydraulic components). Doing so will invalidate all warranties and Capacity Charts and make the crane owner/user liable for any resultant accidents.
29. **Keep crane clean.** Accumulations of dirt, grease, oil, rags, paper, and other waste will not only interfere with safe operation and maintenance but also create a fire hazard.
30. Store tools, oil cans, spare parts, and other necessary equipment in tool boxes. Do not allow these items to lie around loose in the operator cab or on walkways and stairs.
31. Do not store flammable materials on the crane.
32. Do not return the crane to service at completion of maintenance or repair procedures until all guards and covers have been reinstalled, trapped air has been bled from hydraulic systems, safety devices have been reactivated, and all maintenance equipment has been removed.
33. Perform a function check to ensure proper operation at the completion of maintenance or repair.

## ENVIRONMENTAL PROTECTION

**Dispose of waste properly!** Improperly disposing of waste can threaten the environment.

Potentially harmful waste used in Manitowoc cranes includes — but is not limited to — oil, fuel, grease, coolant, air conditioning refrigerant, filters, batteries, and cloths which have come into contact with these environmentally harmful substances.

Handle and dispose of waste according to local, state, and federal environmental regulations.

When filling and draining crane components: do not pour waste fluids onto the ground, down any drain, or into any source of water.

- Always drain waste fluids into leak proof containers that are clearly marked with what they contain.
- Always fill or add fluids with a funnel or a filling pump.
- Immediately wipe up any spills.

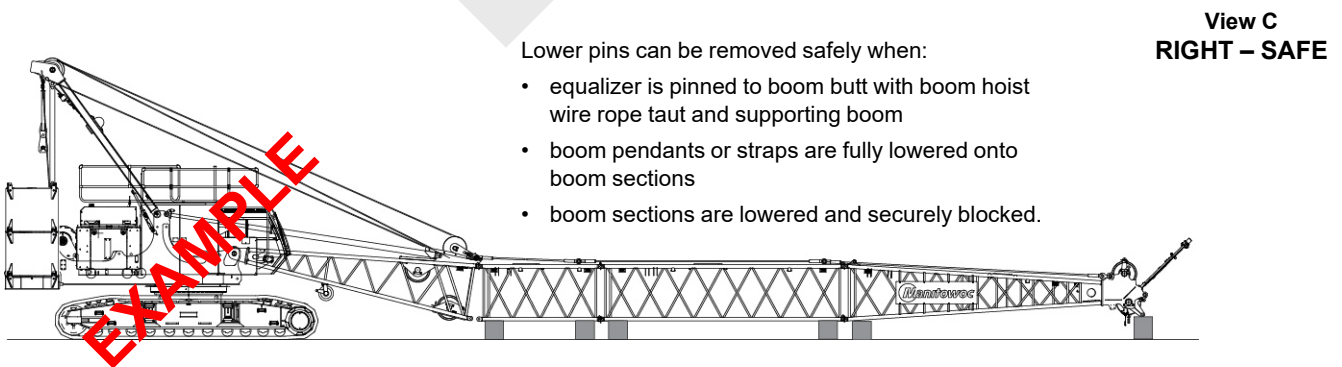
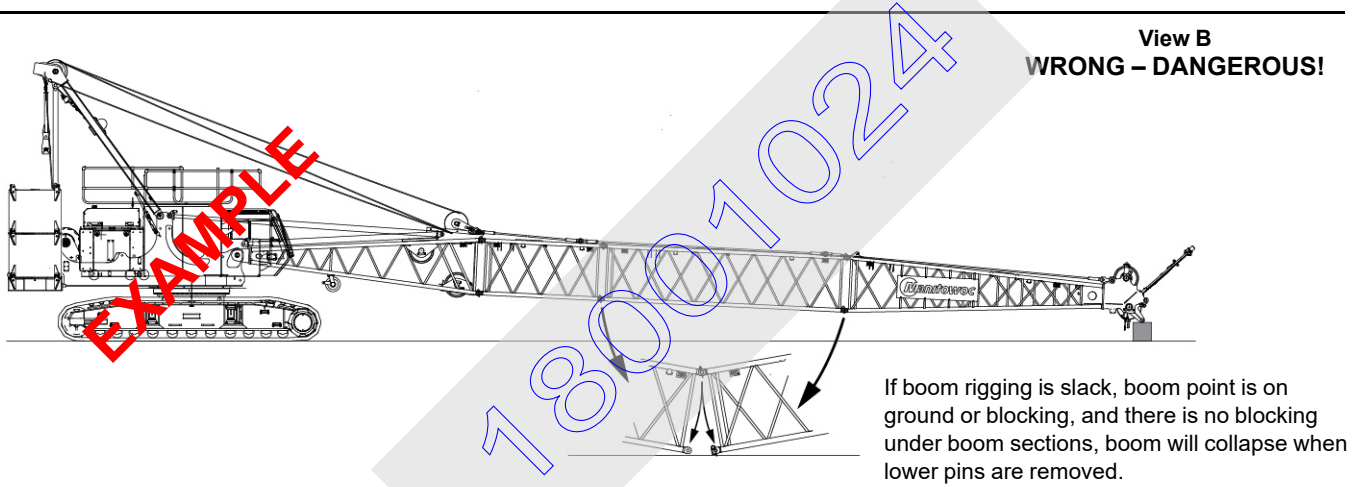
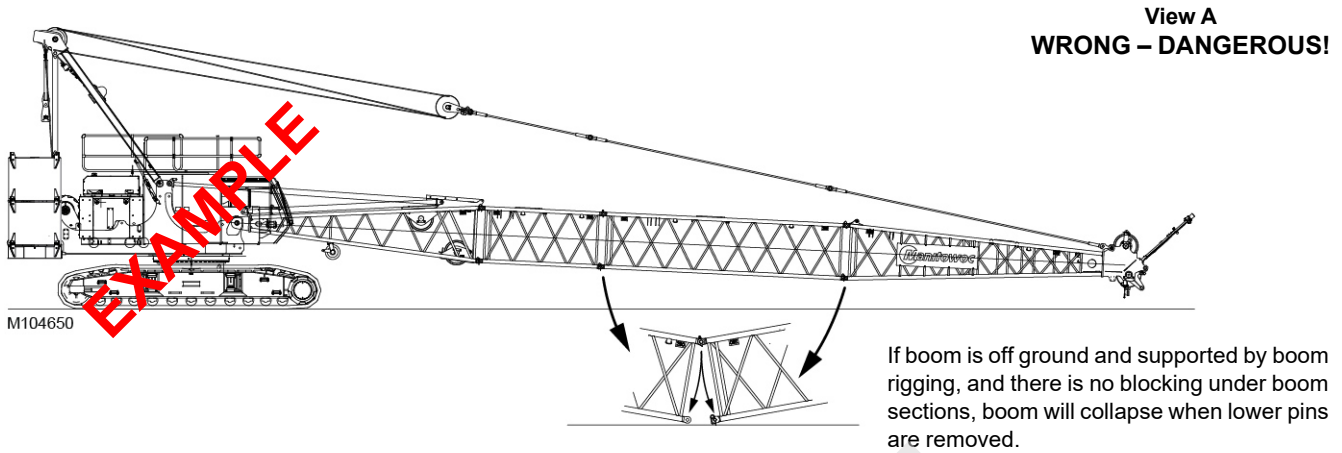

Figure 2-4. Boom Disassembly

## BOOM DISASSEMBLY SAFETY

**NOTE** The term “boom” used in the following instructions applies to all lattice attachments (fixed jib, luffing jib, mast, etc.).



**DANGER!**

### Collapsing Boom Hazard!

Prevent death or serious injury when disassembling boom sections — read and adhere to the following instructions.

Safe handling of lattice booms during disassembly is a primary concern for preventing serious or fatal injuries. A boom can collapse during disassembly if workers fail to observe safe working practices.

Accidents during boom disassembly usually result from one of three primary causes:

- Workers are not familiar with equipment or are not properly trained.
- Disassembly area is not suitable.
- Safe procedures are overlooked because not enough time is allocated for the task.

### General

Safety decals ([Figure 2-5](#)) are placed near the connectors of the boom sections as shown on the Boom Disassembly Decal Drawing at the end of this section.

Workers involved with boom disassembly shall be trained and experienced in the operation and disassembly of construction cranes. Everyone shall read and understand these instructions, the information in the Boom Assembly Drawing, and the instructions in Section 4 before beginning disassembly. Anyone who has a question should ask for an explanation. **One worker who does not fully understand or fails to follow correct procedures can endanger other workers.**

### Location

Select a suitable location for boom disassembly. It must be firm, level, and free of obstructions. It should have enough open space to accommodate the crane, the length of boom, and – if required – movement of an assist crane or other equipment. If possible, secure the area to keep unauthorized personnel and vehicles away.

### Pin Removal

When removing pins from boom sections, stand clear of pins being removed. Even though the boom is resting on

blocking, individual pin connections may still be under load. Pins can be ejected forcefully if the boom has any pressure on it or if the boom is not supported properly.

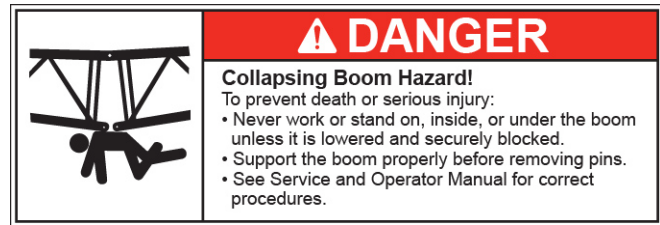

M101904

Figure 2-5. Safety Decal

## Disassembly Precaution

Always block boom sections so they are securely supported and cannot shift or move suddenly when pins are removed. If there is any doubt about a boom disassembly procedure, **block tightly under boom sections before removing any pin.**



**DANGER**

### Collapsing Boom Hazard!

Boom can collapse or jerk when pins are removed. To avoid death or serious injury:

- Do not remove bottom connecting pins from any boom section when boom is supported by pendants as shown in [Figure 2-4](#), View A.
- Do not remove pendant connecting pins until pendants are fully lowered onto boom sections as shown in [Figure 2-4](#), View C.
- Do not remove bottom connecting pins from any boom section when boom point is resting on ground or blocking and boom rigging is slack as shown in [Figure 2-4](#), View B.
- Never work or stand inside boom unless it is lowered and securely blocked as shown in [Figure 2-4](#), View C.
- Do not stand or walk on top of the boom.



**DANGER**

### Falling Boom Hazard!

Crane can tip or the boom can collapse if excess boom is cantilevered. Never cantilever more boom than allowed in rigging drawing or capacity chart.



## SPECIAL APPLICATION/SERVICE

Special Application/Service is defined as anything other than normal lifting activities or normal lifting operation.

As identified in ASME B30.5, cranes are sometimes used for service other than lifting service and/or special lifting operations. In such cases Manitowoc or a qualified person shall review the service to be performed and jobsite conditions prior to operation. If appropriate, Manitowoc or a qualified person shall determine and establish a reduction in rated capacity, operating limitations, maintenance, testing and inspection requirements based on the job site conditions/limitations.

Because Manitowoc is not aware of all job site conditions/limitations we cannot provide further guidance until the intended service is understood, and a review of the conditions/limitations is complete.

Manitowoc cannot foresee all hazards that will arise in the field related to the special applications/services below; therefore, safety remains the responsibility of the qualified lifting personnel involved in the crane operations and owners.

Additional resources, training and experience may exist in the crane industry to provide guidance of risk assessments and hazard avoidance regarding special applications/service.

## PERSONNEL HANDLING POLICY

In 1998, the American Society of Mechanical Engineers issued a new American National Standard entitled, Personnel Lifting Systems, ASME B30.23-1998. This standard provides, ***“lifting and lowering of personnel using ASME B30 Standard hoisting equipment shall be undertaken only in circumstances when it is not possible to accomplish the task by less hazardous means. Unless all of the applicable requirements of this volume are met, the lifting or lowering of personnel using ASME B30 Standard equipment is prohibited.”***

The ASME Standards recognize that mobile and locomotive cranes are primarily designed and intended for handling materials and not personnel. The ASME Standards have a retrofit statement that applies to existing cranes after the standards go into effect. It is not the intent of the standards to require retrofitting of existing equipment. If an item is being modified, the performance requirement must be reviewed relative to the current standard.

This new standard is consistent with the U.S. Department of Labor, Occupational Safety and Health Administration (OSHA) regulations for Construction that state, in 29CFR1926.1431(a): ***The use of a crane or derrick to hoist employees on a personnel platform is prohibited, except when the erection, use, and dismantling of conventional means of reaching the work site, such as a***

***personnel hoist, ladder, aerial lift, elevating work platform or scaffold, would be more hazardous or is not possible because of structural design or work site conditions.***

Use of a Manitowoc crane to handle personnel is acceptable provided:

- The crane user shall comply with the manufacturer's specifications and limitations for lifting accessories (hooks, slings, personnel platforms, etc.).
- The requirements of the applicable national, state and local regulations and safety codes are met.
- A determination has been made that use of a crane to handle personnel is the least hazardous means to perform the work.
- The crane operator shall be qualified to operate the specific type of hoisting equipment used in the personnel lift.
- The crane operator shall remain in the crane cab at all times when personnel are off the ground.
- The crane operator and occupants have been instructed in the recognized hazards of personnel platform lifts.
  - The crane is in proper working order.
  - Load and boom hoist drum brakes, swing brakes, and locking devices such as pawls and dogs must be engaged when the occupied personnel platform is in a stationary position.
- The crane must be equipped with a boom angle indicator that is visible to the crane operator.
- The crane must be equipped with boom hoist limiting device.
- If the luffing jib is used for hoisting personnel, the crane must be equipped with a luffing jib angle indicator that is visible to the crane operator.
- If the luffing jib is used for hoisting personnel, the crane must be equipped with a luffing hoist limiting device.
- The crane is equipped with a positive acting device which prevents contact between the load block or overhaul ball and the boom tip (anti-two-block device).
 

For friction cranes, this implies the addition of spring applied brakes activated by the anti-two-block device. The load line hoist drum must have a system or device on the power train, other than the load hoist brake, which regulates the lowering rate of speed of the hoist mechanism (controlled load lowering).

***Free fall of the hoist line is prohibited.***
- The Operator Manual is in the cab, readily accessible to the operator.

- The crane's load Capacity Chart is affixed inside the crane cab, readily accessible to the operator. The total weight of the loaded personnel platform and related rigging must not exceed 50 percent of the rated capacity for the radius and configuration of the crane.
- The crane is uniformly level within one percent of level grade and located on a firm footing. Some Capacity Charts require more stringent levelness criteria.

Cranes with outriggers or stabilizers must have them all extended and locked. All outriggers or stabilizers must be extended equally in accordance with the Capacity Charts and operating procedures.

- Handling personnel from a platform suspended by wire rope from a luffing jib is acceptable, but only when it is not possible to accomplish the task using a less hazardous means. The crane user and operator shall take into account hazards that may be present when using a luffing jib.
- Direct attachment of a personnel platform to a luffing jib is prohibited.
- The platform meets the requirements as prescribed by applicable standards and regulations.
- Applicable personal protection equipment is provided (for example, personal fall-protection system).
- For wire rope suspended platforms, the crane is equipped with a hook latch that can be closed and locked, eliminating the throat opening.
- The platform is properly attached and secure.
- Personnel platforms must not be used in winds exceeding 20 mph (9 m/s) at the hoisted platform height or in electric storms, snow, ice, sleet, or other adverse weather conditions which could affect the safety of personnel.
- Hoisting personnel within 6 m (20 ft) of a power line that is up to 350 kV or within 15 m (50 ft) of a power line that is over 350 kV is PROHIBITED, except for work covered in OSHA 29CFR1926 subpart V.

For operation outside the United States, the requirements of the applicable national, state and local regulations and safety codes must be met. This may include, in addition to the above:

- Automatic brakes such that when the equipment operating controls are released, the motions are brought to rest.
- A holding device (such as a load hold check valve) must be provided in the hydraulic or pneumatic

systems to prevent uncontrolled movement of the hoisting equipment in the case of a system failure.

Manitowoc offers upgrade packages for friction controlled models to install anti-two-block, dead man control, and automatic hoist system control requirements to satisfy other codes and standards.

Manitowoc recommends that cranes be properly maintained, regularly inspected, and repaired as necessary. All safety signs must be in place and legible. We also urge Manitowoc crane owners to upgrade their cranes with rated capacity indicator/limiter systems for all lifting operations.

In 2016, **The International Crane Stakeholder Assembly** published a guidance document titled *Lifting of Persons with Mobile Cranes*. This document may assist crane owners and lifting personnel in the risk assessment of personnel handling.

If you have any questions about this subject or other product safety matters relating to the operation and use of a Manitowoc crane, please contact your Manitowoc dealer or the Product Safety and Reliability Department at the following address:

Manitowoc Cranes  
2401 So. 30th St.  
Manitowoc, WI 54220  
Phone: 920-684-6621

## PEDESTAL/BARGE MOUNTED CRANES



### WARNING

#### Overload Hazard!

A pedestal mounted crane will not tip to indicate to the operator that the crane's capacity has been exceeded. When the capacity of a pedestal mounted crane is exceeded, the hook rollers or other structural components may break, before the load lines fail, causing the crane to separate from the pedestal.

For this reason, great care must be taken to operate a pedestal mounted crane within its rated capacity.

Careful planning is required before a crane can be operated on a barge. The crane user shall verify that the barge is capable of limiting crane list and/or dynamics to the maximum allowable specified in the Capacity Charts. If the specified crane list and/or dynamic conditions are exceeded, the crane's capacity may be exceeded; the hook rollers or other structural components may break, causing the crane to separate from the pedestal.

**! WARNING**

The crane owner/user shall verify that the method used to fasten or restrain the crane to the foundation, the barge, the ship or the floating platform is strong enough, under all operating conditions, to prevent the crane from breaking off the foundation or moving on the barge.

Manitowoc does not permit use of a lattice boom truck crane on a barge, a ship, or a floating platform.

**Pedestal Mounted Crane**

Also see ASME publication B30.8-2015, Floating Cranes and Derricks.

**Definition**

A pedestal mounted crane is a crane which is securely fastened to a foundation, barge, ship, or floating platform so the crane is restrained from tipping.

**Examples**

1. Crane rotating bed mounted on a turret (pedestal) which is securely fastened to the foundation (Figure 2-6).

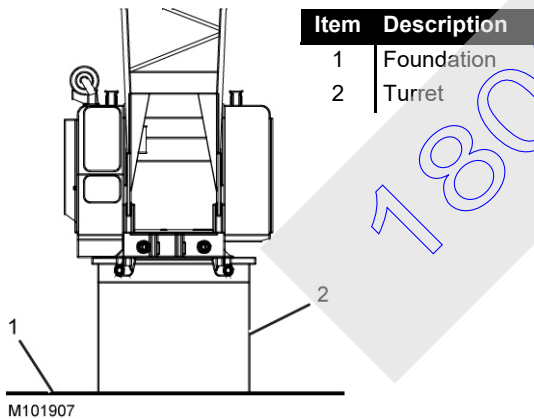

**Figure 2-6. Turret-Mounted Crane**

2. Crane rotating bed mounted on a carbody (crawlers removed) which is securely fastened to the foundation (Figure 2-7).

**NOTE** If the carbody will be bolted to the foundation, contact your Manitowoc dealer for the recommended bolt pattern and for the type and quantity of bolts to be used.

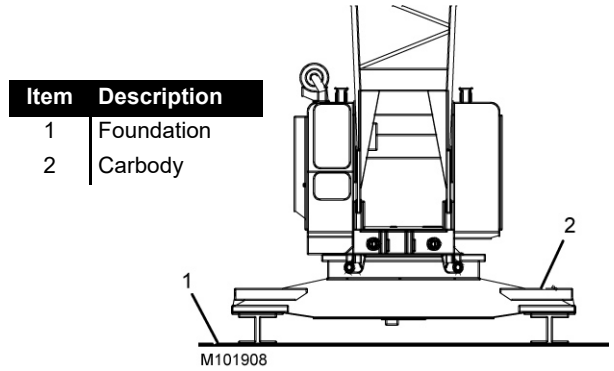

**Figure 2-7. Carbody-Mounted Crane**

**Barge Mounted Crane**

**Definition**

A barge mounted crane is a crane that is anchored or restrained in a work area of the barge, ship, or floating platform and is subjected to tipping forces.

**Examples**

**NOTE** The foundation is the deck of the barge, ship, or floating platform.

1. Crawler-mounted crane with the carbody anchored with tie-downs to the foundation (Figure 2-8).

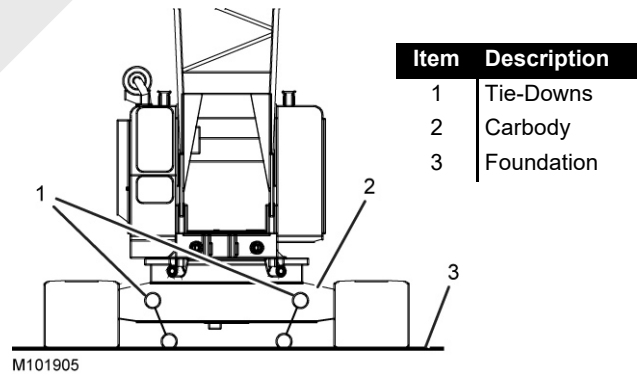

**Figure 2-8. Crawler-Mounted Crane**

2. Crawler-mounted crane working on a timbered area of the barge, ship, or floating platform with the crawlers restrained by curbing and end stops (Figure 2-9). When not working, the crane carbody is anchored with tie-downs to the foundation. **Traveling with load is not permitted.**

**NOTE** Manitowoc does not permit traveling on a barge deck with load.

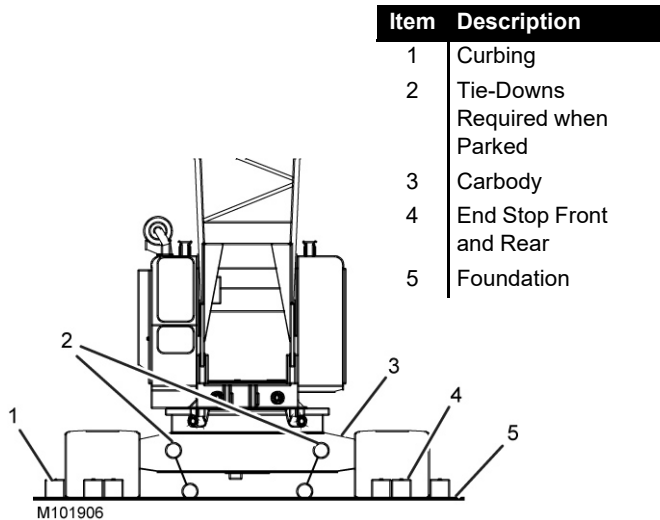

Figure 2-9. Crawler-Mounted Crane

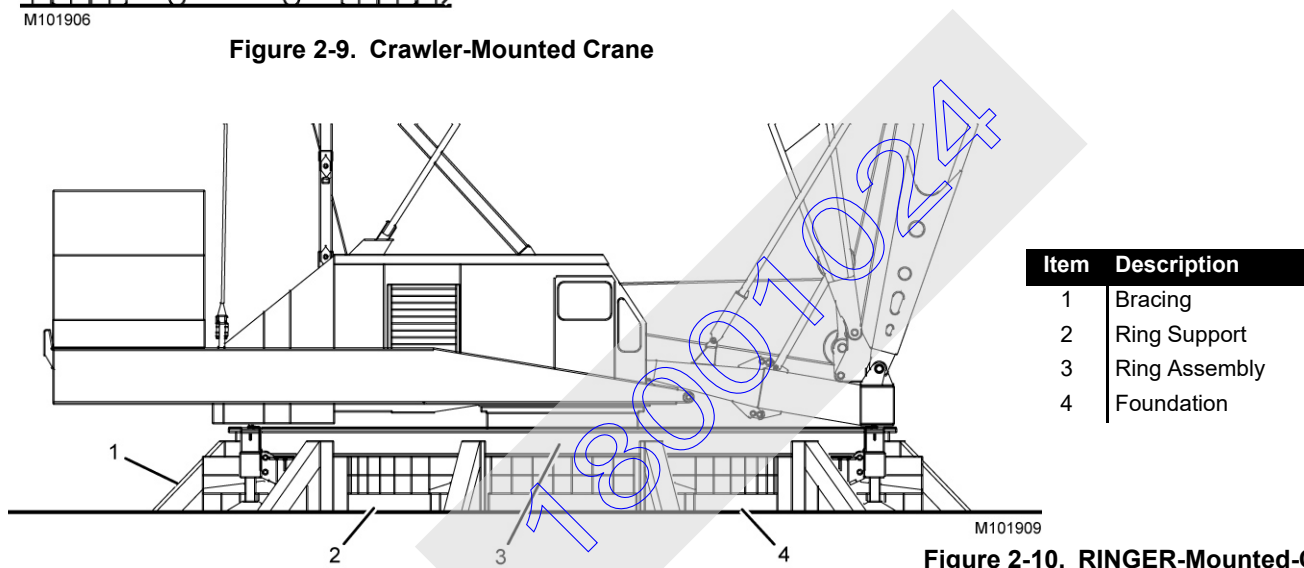
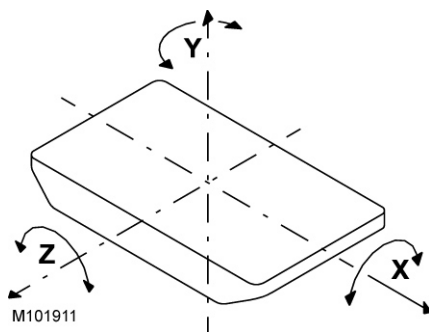

Figure 2-10. RINGER-Mounted-Crane



AXIS		TRANSITIONAL		ROTATIONAL	
SYMBOL	NAME	STATIC	DYNAMIC	STATIC	DYNAMIC
X	Longitudinal		Surge	Heel List	Roll
Y	Vertical		Heave		Yaw
Z	Lateral		Sway	Trim	Pitch

Figure 2-11. Barge Dynamics

3. RINGER® (crawler mounted, carbody mounted) supported on blocking, screw jacks, or steel pedestals which are braced and fastened to the foundation in such a manner as to prevent movement (Figure 2-10).

**NOTE** RINGERS must be equipped with hook rollers on the boom carrier and the counterweight carrier.

4. RINGER (platform mounted) which has the ring braced and fastened directly to the foundation in such a manner as to prevent movement.

### Capacity Charts for Barge Mounted Crane

Manitowoc provides two types of Capacity Charts for a crane mounted on a barge or other supporting structure under static conditions.



1. A Capacity Chart based on tipping when the crane is anchored only to prevent shifting.
2. A Capacity Chart based on structural competence when the crane is securely fastened for use as a pedestal mounted crane.

**NOTE** Unless otherwise specified in a machine list Capacity Chart, a 0 degree machine list Capacity Chart rating applies to machine list **not to exceed 1/2 degree**. All other machine list ratings – 1°, 2°, and 3° – must NOT be exceeded.

**Shock Loading Caused by Barge Dynamics**

Shock loads to the crane can be experienced when the barge is subjected to up and down movement of wave action (referred to as DYNAMICS). Figure 2-11 illustrates the dynamic conditions of the barge which influence crane capacity.

**CAUTION**

**Structural Damage Hazard!**

If the crane's boom or structure is shock loaded during operation, or there is any indication of shock loading, all structural components of the crane must be inspected to detect cracks and other damage. Nondestructive test equipment, such as magnetic particle or ultrasonic procedures, is recommended for this inspection.

**NOTE** Manitowoc does not recommend crane operation under dynamic conditions.

**Operation on Barge**

Machine list and/or dynamics will be experienced when a crane is operated on a barge, ship, or floating platform. Both of these conditions reduce the crane's capacity and each must be taken into account for safe operation on a barge, ship, or floating platform.



**WARNING**

**Tipping Crane Hazard!**

Tie-downs which only prevent the crane from shifting as in barge, ship or floating platform mounting, may not provide adequate support when using a Capacity Chart for pedestal mounting. Before operating a crane on a barge, a ship or a floating platform, the crane user shall verify that correct the Capacity Chart is being used — pedestal mounted, barge mounted, 0°, 1°, 2° or 3° list or dynamic Capacity Chart.

Failing to use the correct Capacity Chart can result in an accident.

**Barge Mount Definitions**

1. Machine List, as defined by Manitowoc, is the crane's out-of-level condition — from side-to-side — as measured by the angle between horizontal and a line drawn through the centerline of the crane's boom hinge pins (Figure 2-12). This out-of-level condition creates side load and affects the crane's lifting capacity.

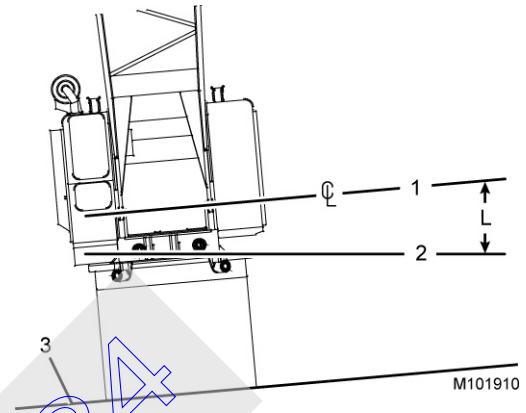

Item	Description
1	Centerline through Boom Hinge Pins
2	Horizontal
3	Barge Deck
L	Degrees of Machine List (Maximum allowable is specified in Capacity Chart)

**Figure 2-12. Machine List**

2. Barge List (also referred to as heel or trim) causes swing out of the load and may produce side load. When Manitowoc provides a Capacity Chart showing capacities for a 2 degree machine list for example, we are referring to the maximum allowable lifting capacity for the crane when experiencing an out-of-level condition (side-to-side) of 2 degrees as measured by angle between horizontal and a line drawn through centerline of the crane's boom hinge pins.

Unless otherwise specified in the Capacity Chart, barge list (heel or trim) must not exceed the machine list degrees given in the Capacity Chart.

3. Barge List and Machine List are not the same. As the crane rotates on a barge, barge list (as defined above) will change. The worst machine list condition generally occurs when the crane swings over the corner of the barge, producing maximum side load.

**Inspection of Barge-Mounted Crane**

To aid in preventing harmful and damaging failure as previously indicated, regular inspection for signs of overloading in the following load bearing components is

required. Correct each defect found before placing the crane into service.

- Boom
- Counterweight
- Backhitch
- Rotating Bed
- Wire Rope
- Pendants and Straps
- Hook and House Rollers

When equipped with hook rollers, it is recommended that each hook roller assembly be inspected daily for any sign of overloading, to include:

- Deformation of roller path
- Proper hook roller adjustment
- Deformation or cracks in hook roller hanger
- Bent hook roller shaft
- Damaged bearings

## Transporting Crane on Barge

If it is necessary to transport the crane on a barge, ship, or floating platform when dynamic conditions will be experienced, the boom must be lowered onto a cradle (or other support) and the crane's boom, rotating bed, and lowerworks must be secured against movement. If the crane is equipped with a mast, the mast must be securely tied down with guylines. Failing to take these steps can result in shock load or side load damage to the boom and mast.

## PILE DRIVING AND EXTRACTING

### Introduction

By operating within the following guidelines, pile driving is an approved application for Manitowoc brand mobile crawler cranes. Because pile driving and extracting presents many variables and unknowns, Manitowoc crane owners shall exercise discretion when considering the use of a crane for this application.

It is not our intention to recommend specific types or makes of pile driving and extracting equipment but rather to advise crane owners of our operational requirements to help avoid pile driving and extracting from having any detrimental effect on the crane and invalidating the new machine warranty. The following are the operating requirements that must be used during pile driving and extracting with a Manitowoc crawler crane. These notes are in addition to any guidelines published on the crane's capacity charts.

## Operation of Pile Driving and Extracting Equipment

1. The combined weight of the drive or extractor, piling, leads, attachments, etc., must not exceed the published load chart values. A qualified person shall determine if additional capacity reductions are necessary.
2. The pile driver or pile extractor must be kept clear of the boom top at all times.
3. The crane operator shall ensure that the crane is not subject to impact loading or vibration being induced into the boom and crane structure by meeting the rate of descent of the driver and piling.
4. Pile driving or extracting must be restricted to the boom. A qualified person shall determine an appropriate configuration.
5. Pile Extraction is only permitted when using extraction devices that do not transmit vibration or shock loading into the crane. All possible precautionary measures must be taken to prevent shock loads or vibration from being imposed on crane components, either directly through the hoist cable or indirectly from ground borne vibration. Do not exceed load capacity.
6. The crane operator and other personnel associated with the pile driving and pile extraction operation shall have read and understood all safety standards applicable to crane operations as well as being thoroughly trained in the safe operation of pile driving and extracting equipment.
7. The load lines must be kept vertical at all times during pile driving and pile extraction operations.

## Crane Equipment

1. Manitowoc recommends that hoist cable length be reduced to operate on the first layer for optimal spooling.
2. Crane must be assembled per applicable rigging drawing and operator manual.
3. All hoist hooks must be equipped with a positive locking latch.
4. Refer to the specific hook block or headache ball manufacturer website for additional guidelines on usage in pile driving applications.

## Crane Inspection

1. In addition to the crane's frequent and periodic inspections, dated daily records must be maintained showing inspections were performed on the crane during the time it was used for pile driving or extraction.
2. The "40 Hours of Operation or Weekly" boom related inspection intervals published in the crane's *Inspection*

*and Maintenance Checklist* must be increased to 8 hour or daily intervals for the duration of pile driving operations.

3. The hoist cable must be inspected daily to ensure no abrasion or wear is occurring.

In 2014, **FEM**, a member of **The International Crane Stakeholder Assembly** published a guidance document titled *Using Mobile Cranes for Pile Driving/Extraction*. Additionally, ASSE A 10.19 Safety Requirements for Pile Installation and Extraction Operations may assist crane owners and lifting personnel in the risk assessment related to pile driving/extraction.

## ELECTROCUTION HAZARD DEVICES

The use of insulated links, insulated boom cages/guards, or proximity warning devices does not assure that electrical contact will not occur. Therefore, Manitowoc does not endorse their use. When insulated links, insulated boom cages/guards, or proximity warning devices are installed on the crane as required by Regulations, Industry Codes, or company policies, the crane owner is responsible for ensuring that:

- a. The device manufacturer is contacted and provides instructions for storage, inspection, maintenance, and use of the devices.
- b. The device manufacturer provides all limitations and restrictions of the device.
- c. The documentation provided by the device manufacturer is maintained on the crane and available to the crane operator at all times.

Further, when insulated links, insulated boom cages/guards, or proximity warning devices are installed on the crane, a pre-operational meeting is to be held and a review of the instructions, limitations and restrictions related to the device(s) will be communicated to all personnel that are to work on or around the crane.

Even if the crane is equipped with these devices, failure to follow the rules, limitations and precautions outlined in this manual and provided by the device manufacturer at all times may result in serious injury or death.

**Do not depend on grounding.** Grounding of a crane affords little or no protection from electrical hazards. The effectiveness of grounding is limited by the size of the conductor (wire) used, the condition of the ground, the magnitude of the voltage/current present, and numerous other factors.

## MULTIPLE LOAD LINE OPERATION

Multiple load line operation is becoming common practice for applications like panel tilt-up, pile tilt-up, pile driving, rolling fabricated sections, etc. The multiple load lines may be on a

common shaft (each with different parts of line) or on multiple shafts (lower boom point and upper point, boom point and fixed jib point, etc).

Manitowoc authorizes multiple load line operation for those applications requiring it, provided the following steps are performed:

1. The qualified lift planner and crane operator shall read and become thoroughly familiar with the appropriate Capacity Charts and Wire Rope Specification Charts.
2. The lift planner and the crane operator shall make sure the total load does not exceed the rated capacity given in the Capacity Chart and Wire Rope Specification Chart for given boom point or jib point, whichever is less.

EXAMPLE: If one load line is lifting from the jib point, the proper jib chart applies.

3. The crane must be thoroughly inspected by a qualified person prior to setup.
4. The crane must be thoroughly inspected for load line interference caused by routing and reeving of multiple load lines. If interference is found, it must be eliminated.
5. For cranes produced before 2003, Rated Capacity Indicators/Limiters were not required by ASME B30.5 for non-personnel lifting.

To aid the operator in staying within the crane's Capacity Chart with the total applied load, Manitowoc recommends that its cranes be equipped with Rated Capacity Indicators/Limiters to monitor the load on each load line.

**Operator is still responsible for knowing load and radius whether or not the crane is equipped with load indicator(s).**

6. Manitowoc recommends that each load line be equipped with an anti two-block device.
7. Manitowoc's Capacity Charts are based on freely suspended loads. To prevent side load damage to the boom, jib, and sheaves:
  - The load lines must hang as close to vertical as possible to minimize side and forward loads.
  - The load must remain centered on the boom and jib point shafts unless special lift approval is granted by Manitowoc.
  - The load lines should be located over the load's center of gravity as it is supported on a trailer, a barge, or the ground.
8. To minimize the angle of the load transmitted into the boom and/or jib, the distance between the load points and the hook points must be a minimum of three times the horizontal distance between the hook point on the load being lifted.

9. The crane operator shall be familiar with the operational characteristic of the crane as it relates to multiple drum operation (simultaneous operation, same or opposite direction, or individual operation).
10. When using tandem drums, the maximum operating layers may be limited depending on whether the crane was initially designed for tandem drum operation or not.
11. Load shift when lifting with two hooks may be more unpredictable than typical one hook lifting.

## MULTIPLE CRANE LIFTS

Operate with extreme caution when using more than one crane to lift the same load. Any lift that requires more than one crane to lift the same load must be precisely planned and coordinated by a qualified person due to new and different hazards.

The following additional precautions must be taken if it is necessary for more than one crane to lift the load:

- a. Secure the services of a qualified person to analyze and plan the lift.
  - b. Verify proper controls are in place to prevent overload such as the necessity to reduce crane ratings, load position, boom position, ground support, and speed of movements. These controls must be in accordance with the qualified person's decision and all other requirements identified in the operator manual.
- c. Ensure the lift director coordinates and instructs all personnel involved in the lift plan, to include but limited to, proper rigging and positioning of the load and all movements to be made prior to beginning the lift.
  - d. Make sure all signals are coordinated through the lift director.
  - e. A qualified person must direct the lift.
  - f. Maintain communication between all parties throughout the entire lift. If possible, provide approved radio equipment for voice communication between all parties engaged in the lift.
  - g. Ensure the load lines are directly over the attach points to avoid side loading, forward loading, and transfer of loading from one crane to the other.

In 2016, **The International Crane Stakeholder Assembly** published a guidance document titled *Lifting A Load With Several Mobile Cranes (Multiple Crane or Tandem Lifting)*. This document may assist crane owners and lifting personnel in the risk assessment of multiple crane lifts.

## SECTION 3

### OPERATING CONTROLS AND PROCEDURES

#### TABLE OF CONTENTS

Standard Hand Signals for Controlling Crane Operations . . . . .	3-2
Symbol Identification . . . . .	3-4
Cab Door Adjustment . . . . .	3-11
General . . . . .	3-11
Closing Cab Door . . . . .	3-11
Damper Adjustment . . . . .	3-11
Front Window Operation . . . . .	3-12
Closing Window . . . . .	3-12
Opening Window For Ventilation . . . . .	3-12
Opening Window For Emergency Exit . . . . .	3-12
Crane Orientation . . . . .	3-12
Operating Controls . . . . .	3-12
Display Language . . . . .	3-12
Controls Identification And Function . . . . .	3-14
A – Engine Controls . . . . .	3-14
A1. Engine Stop/Run/Start Switch . . . . .	3-14
A2. Engine Stop Switch . . . . .	3-14
A3. Engine Diagnostics Lights . . . . .	3-14
A4. Engine Hand Throttle . . . . .	3-14
A5. Engine Foot Throttle . . . . .	3-14
A6. Engine Clutch Handle . . . . .	3-14
A7. Battery Disconnect Switch . . . . .	3-14
A8. DPF Switch (Tier 4 Equipped) . . . . .	3-15
B – Accessory Controls . . . . .	3-17
B1. Cab Tilt Switch . . . . .	3-17
B2. Panel Lights Switch . . . . .	3-17
B3. Dome Light Switch . . . . .	3-17
B4. Climate Control . . . . .	3-17
B5. Overhead Windshield Wiper Switch . . . . .	3-17
B6. Front Windshield Wiper and Washer Switch . . . . .	3-17
B7. Crane Work Lights Switch . . . . .	3-19
B8. Accessory Control Panel . . . . .	3-19
B9. Radio/CD Player . . . . .	3-19
B10. Horn Switches . . . . .	3-19
B11. 12V Power Supply Receptacle . . . . .	3-19
B12. Machinery Heaters . . . . .	3-19
B13. Tinted Visor and Shade . . . . .	3-19
B14. Cab RCL Rotating Beacon . . . . .	3-19
B15. Cab Door Brake . . . . .	3-19
B16. Anemometer . . . . .	3-19
C – Indicators . . . . .	3-21
C1. RCL (Rated Capacity Indicator/Limiter) Controls . . . . .	3-21
C2. System Fault Alert . . . . .	3-21
C3. Operating Limit Alert . . . . .	3-21
C4. Rear View Mirrors . . . . .	3-21
C5. Boom Angle Indicator . . . . .	3-21
C6. Level . . . . .	3-21
C7. Hydraulic Level and Temperature Gauge . . . . .	3-21
C8. Drum Rotation Indicators . . . . .	3-21
C9. Fuel Level . . . . .	3-21
C10. Engine Coolant Temperature . . . . .	3-21

C11. Engine Oil Pressure . . . . .	3-21
C12. Battery Voltage . . . . .	3-21
D – Special Controls . . . . .	3-22
D1. Drum 5 (Mast Hoist) Park Switch . . . . .	3-22
D2. Seat Switch . . . . .	3-22
D3. Dead-Man Switch (Optional) . . . . .	3-22
D4. Digital Display . . . . .	3-22
D5. Scroll Selector . . . . .	3-22
D6. Digital Display Contrast Switch . . . . .	3-22
D7. Crane Mode Confirm/Select Switch . . . . .	3-22
D8. Limit Bypass Switch . . . . .	3-24
E – Boom/Luffing Hoist Controls . . . . .	3-28
E1. Drum 4 (Boom Hoist) Park Switch . . . . .	3-28
E2. Drum 6 (Luffing Jib Hoist) Park Switch . . . . .	3-28
E3. Boom/Luffing Hoist Handle A . . . . .	3-28
E4. Boom/Luffing Hoist Handle Display Light . . . . .	3-28
F – Load Drum Controls . . . . .	3-29
F1. Drum 1 (Main Hoist 1) Park Switch . . . . .	3-29
F2. Drum 2 (Main Hoist 2) Park Switch . . . . .	3-29
F3. Drum 3 (Whip Line Hoist) Park Switch . . . . .	3-29
F4. Control Handle B . . . . .	3-29
F5. Control Handle C . . . . .	3-29
F6. Control Handle D . . . . .	3-29
F7. Control Handle Display Lights . . . . .	3-29
G – Swing Controls . . . . .	3-30
G1. Swing Park Switch . . . . .	3-30
G2. Swing Handle . . . . .	3-30
G3. Swing Holding Brake Switch . . . . .	3-30
H – Travel Controls . . . . .	3-31
H1. Travel Park Switch . . . . .	3-31
H2. Travel Speed Selector . . . . .	3-31
H3. Travel Cruise Selector . . . . .	3-31
H4. Left Crawler Handle . . . . .	3-31
H5. Right Crawler Handle . . . . .	3-31
J – Setup Controls . . . . .	3-31
K – Limit Devices . . . . .	3-31
Max Up 1 (boom) . . . . .	3-32
Block Up . . . . .	3-32
Luffing Jib UP Limits . . . . .	3-32
Luffing Jib Down Limits . . . . .	3-33
Max Bail . . . . .	3-33
Min Bail . . . . .	3-33
Load Moment (Rated Capacity indicator/limiter) . . . . .	3-34
Seat Controls . . . . .	3-34
Preparing Crane for Operation . . . . .	3-35
Calibration Procedures . . . . .	3-35
Operation . . . . .	3-36
Engine Startup . . . . .	3-36
Boom Hoist Operation . . . . .	3-38
Luffing Hoist Operation . . . . .	3-39
Swing Operation . . . . .	3-40
Load Drum Operation . . . . .	3-41
Travel Operation . . . . .	3-42
Stopping Engine/ Leaving Crane Unattended . . . . .	3-44
Remote Controls . . . . .	3-45
General . . . . .	3-45
Controls Identification and Operation . . . . .	3-45



Setup Remote Control . . . . .	3-45
Power Controls . . . . .	3-45
Jacking Controls . . . . .	3-46
Boom Pins Control . . . . .	3-46
Rotating Frame Controls . . . . .	3-46
Mast Controls . . . . .	3-46
Rigging Winch Controls . . . . .	3-47
Engine Speed Control . . . . .	3-47
Crawler Pin Controls . . . . .	3-47
Replacing Batteries in Setup Remote Control . . . . .	3-47
Digital Display Screens . . . . .	3-48
Crane Operating Conditions . . . . .	3-48
Operating Limits . . . . .	3-49
System Faults . . . . .	3-49
Function Speed/Torque Adjustment . . . . .	3-55
Engine Diagnostics . . . . .	3-55
General . . . . .	3-55
Onboard Engine Diagnostics . . . . .	3-56
DPF Diagnostics — Cummins QSX 15 (Tier 4) . . . . .	3-56
Crane Diagnostics . . . . .	3-57
General . . . . .	3-57
Drum 1 . . . . .	3-57
Drum 2 . . . . .	3-58
Drum 3 . . . . .	3-58
Drum 4 . . . . .	3-58
Drum 5 . . . . .	3-59
Drum 6 . . . . .	3-59
Swing (Crane) . . . . .	3-59
Trk (Travel) . . . . .	3-60
FCN (Front Console Node) . . . . .	3-60
CAN (Can Bus) . . . . .	3-61
Hydraulic System Calibration . . . . .	3-63
Speed/Torque . . . . .	3-63
Accessory System . . . . .	3-63
Wireless . . . . .	3-63
Block Level Sensor . . . . .	3-64
Crane Mode . . . . .	3-64
Hydraulic Fan (Tier 4 only) . . . . .	3-64
MAX-ER Attachment . . . . .	3-65
Crane Mode Selector — Crane with Swing Lock . . . . .	3-65
Crane Mode Selector — Crane Without Swing Lock . . . . .	3-65
Digital Input and Output Item Tables . . . . .	3-67
Hydraulic System Calibration Procedures . . . . .	3-71
General . . . . .	3-71
Pressure Sender Calibration . . . . .	3-71
Control Calibration . . . . .	3-73
Pump Pressure Test . . . . .	3-74
Charge Pressure Check . . . . .	3-76
Wind Conditions . . . . .	3-82
Cold Weather Heater Package . . . . .	3-85
General . . . . .	3-85
Heaters . . . . .	3-85
Turning Heaters On . . . . .	3-85
Turning Heaters Off . . . . .	3-85
Preparation for Cold Weather . . . . .	3-86
Crane Limitations . . . . .	3-86
Wire Rope . . . . .	3-86

18001024

Cold Weather Starting Aid .....	3-86
Ether .....	3-86
Coolant and Oil Pan Heaters .....	3-86
Cooling System .....	3-86
Battery .....	3-86
Engine Oil .....	3-87
Fuel Oil .....	3-87
Gear Oil .....	3-87
Hydraulic Cranes .....	3-87
Hydraulic Oil .....	3-87
General .....	3-87
Hydraulic Cranes .....	3-87
Circuit Breakers .....	3-87





# SECTION 3 OPERATING CONTROLS AND PROCEDURES





*THIS SECTION STARTS ON THE NEXT PAGE*

18001024

# STANDARD HAND SIGNALS FOR CONTROLLING CRANE OPERATIONS

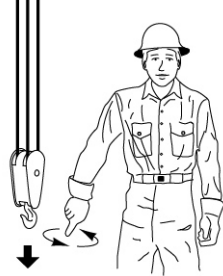
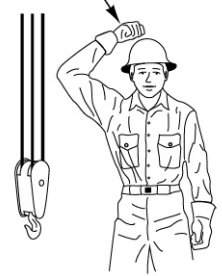
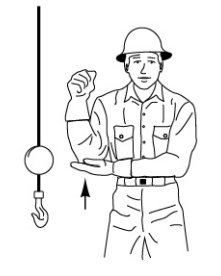
The following standard hand signals comply with ASME B30.5-2014

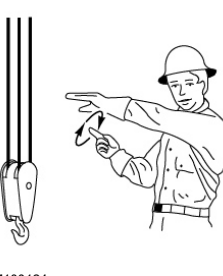
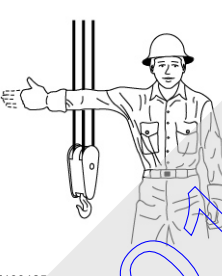
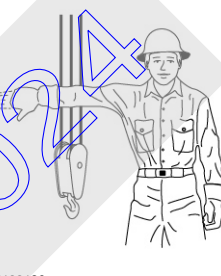
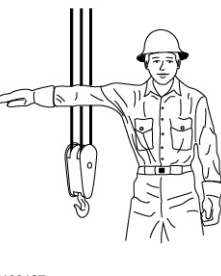
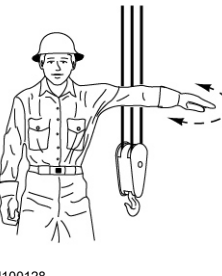
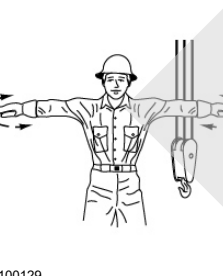
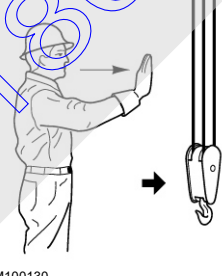
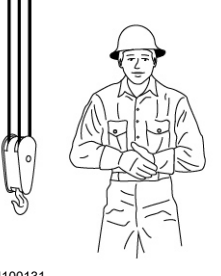
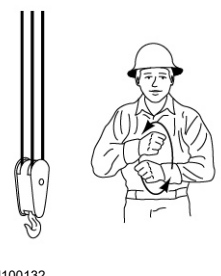
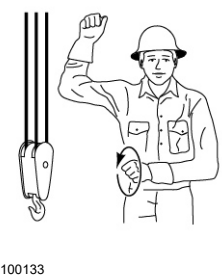
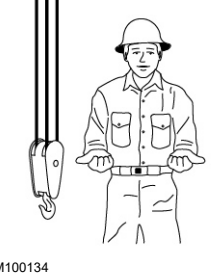
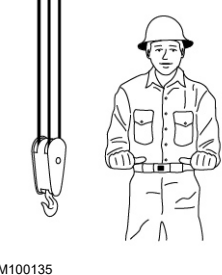
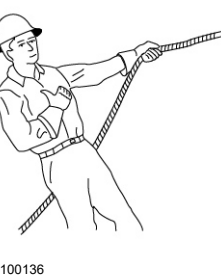
Table 3-1 Standard Hand Signals for Controlling Crane Operations

<p style="text-align: center;"><b>1</b></p>  <p style="text-align: center;">M100118</p>	<p style="text-align: center;"><b>2</b></p>  <p style="text-align: center;">M100119</p>	<p style="text-align: center;"><b>3</b></p>  <p style="text-align: center;">M100120</p>	<p style="text-align: center;"><b>4</b></p>  <p style="text-align: center;">M100121</p>	<p style="text-align: center;"><b>5</b></p>  <p style="text-align: center;">M100122</p>
<p style="text-align: center;"><b>6</b></p>  <p style="text-align: center;">M100123</p>	<p style="text-align: center;"><b>7</b></p>  <p style="text-align: center;">M100124</p>	<p style="text-align: center;"><b>8</b></p>  <p style="text-align: center;">M100125</p>	<p style="text-align: center;"><b>9</b></p>  <p style="text-align: center;">M100126</p>	<p style="text-align: center;"><b>10</b></p>  <p style="text-align: center;">M100127</p>
<p style="text-align: center;"><b>11</b></p>  <p style="text-align: center;">M100128</p>	<p style="text-align: center;"><b>12</b></p>  <p style="text-align: center;">M100129</p>	<p style="text-align: center;"><b>13</b></p>  <p style="text-align: center;">M100130</p>	<p style="text-align: center;"><b>14</b></p>  <p style="text-align: center;">M100131</p>	<p style="text-align: center;"><b>15</b></p>  <p style="text-align: center;">M100132</p>
<p style="text-align: center;"><b>16</b></p>  <p style="text-align: center;">M100133</p>	<p style="text-align: center;"><b>17</b></p>  <p style="text-align: center;">M100134</p>	<p style="text-align: center;"><b>18</b></p>  <p style="text-align: center;">M100135</p>	<p style="text-align: center;"><b>19</b></p>  <p style="text-align: center;">M100136</p>	<p style="text-align: center;"><b>20</b></p>  <p style="text-align: center;">M100137</p>

Reprinted from ASME B30.5-2014, by permission of the American Society of Mechanical Engineers. All Rights Reserved.

Item	Description
1	<b>HOIST</b> —With forearm vertical, forefinger pointing up, move hand in small horizontal circles.
2	<b>LOWER</b> —With arm extended downward, forefinger pointing down, move hand in small horizontal circles.
3	<b>USE MAIN HOIST</b> —Tap fist on head. Then use regular signals.
4	<b>USE WHIPLINE (Auxiliary Hoist)</b> —Tap elbow with one hand. Then use regular signals.
5	<b>RAISE BOOM</b> —Arm extended, fingers closed, thumb pointing upward.
6	<b>LOWER BOOM</b> —Arm extended, fingers closed, thumb pointing downward.
7	<b>MOVE SLOWLY</b> —Use one hand to give any motion signal and place other hand motionless in front of hand giving the motion signal (hoist slowly shown as an example).
8	<b>RAISE BOOM &amp; LOWER LOAD</b> —With arm extended, thumb pointing up, flex fingers in and out as long as load movement is desired.
9	<b>LOWER BOOM &amp; RAISE LOAD</b> —With arm extended, thumb pointing down, flex fingers in and out as long as load movement is desired.
10	<b>SWING</b> —Arm extended, point with finger in direction of swing of boom.
11	<b>STOP</b> —Arm extended, palm down, move arm back and forth horizontally.
12	<b>EMERGENCY STOP</b> —Both arms extended, palms down, move arms back and forth horizontally.
13	<b>TRAVEL</b> —Arm extended forward, hand open and slightly raised, make pushing motion in direction of travel.
14	<b>DOG EVERYTHING</b> —Clasp hands in front of body.
15	<b>TRAVEL (Both Tracks)</b> —Use both fists in front of body, making a circular motion about each other, indicating direction of travel forward or backward. (For Land Cranes Only).
16	<b>TRAVEL (One Track)</b> —Lock the track on side indicated by raised fist. Travel opposite track in direction indicated by circular motion of other fist, rotated vertically in front of body. (For Land Cranes Only).
17	<b>EXTEND BOOM (Telescoping Booms)</b> —Both fists in front of body with thumbs pointing outward.
18	<b>RETRACT BOOM (Telescoping Boom)</b> —Both fists in front of body with thumbs pointing toward each other.
19	<b>EXTEND BOOM (Telescoping Boom) — One Hand Signal.</b> One fist in front of chest with thumb tapping chest.
20	<b>RETRACT BOOM (Telescoping Boom) — One hand signal.</b> One fist in front of chest, thumb pointing outward and heel of fist tapping chest.

### SYMBOL IDENTIFICATION

The following symbols are used on the control consoles to identify the operating controls and their operation.

Air Circulation – Cab		Cylinders – Live Mast	
Air Circulation – Outside		Data, Enter	
Alert, Safety		Data, Save Entered	
Cab Tilt		Drum	
Cylinders, Live Mast – Extend or Retract		Drum – Lower (Load, Boom, Luffing Jib, or Mast) (depends on drum use)	
Cylinders, Jacking – Extend or Retract		Drum – Raise (Load, Boom, Luffing Jib, or Mast) (depends on drum use)	
Cylinders, Jacking – Location	<p><i>Left Front</i> </p> <p><i>Right Front</i> </p> <p><i>Left Rear</i> </p> <p><i>Right Rear</i> </p> <p><i>All</i> </p>	Drum Free Fall (with drum number)	
		Drum Number (identifies drum in use)	

FIGURE 3-1

















Energize (turn on)		Engine Temperature	
Engine		Heater/Defroster	
Engine, Battery Voltage		Horn	
Engine, Fuel		Light, Panel	
Engine Pressure		Light, Dome	
Engine Run		Lighter	
Engine Start		Limit Bypass	
Engine Stop		Limit Bypass, Luffing Jib	

FIGURE 3-1 continued











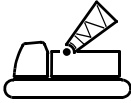



On/Start and Off/Stop		Pins – Main Mast	
Off/Stop		Pins – Rotating Bed Front	
On/Start		Pins – Rotating Bed Rear	
Park Off		Scroll (up, down, and side-ways)	
Park On		Setup Mode	
Pins – Disengage		Speed, Fast	
Pins – Engage		Speed, Slow	
Pins – Boom Hinge		Stop (emergency)	

FIGURE 3-1 continued

Swing		Travel Direction Reverse – Right Crawler	
Swing Left		Travel Speed	
Swing Right		Winch, Rigging	
Travel		Winch, Rigging – Haul In Rope	
Travel Cruise		Winch, Rigging – Pay Out Rope	
Travel Direction Forward – Left Crawler		Windshield Wiper	
Travel Direction Forward – Right Crawler		Windshield Wiper – Overhead with Washer	
Travel Direction Reverse – Left Crawler		Windshield Wiper – Front with Washer	

FIGURE 3-1 continued

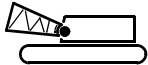

Counterweight, Wheeled		Remote Control	
Raise Counterweight		Set-Up	
Lower Counterweight		Steering	
Jacking Cylinders		Steering Pins	
All		Disengage	
Left Front		Engage	
Left Rear		Wheels	
Right Front		Left	
Right Rear		Right	
Extend Cylinder		Rotate Clockwise	
Retract Cylinder		Rotate Counterclockwise	
Power			

194505

FIGURE 3-1 continued





DPF High Temperature (Tier 4) 	DPF Inhibit On (Tier 4) 
Engine Maintenance Wait-to-Start (Tier 4) 	DPF Condition (Tier 4) 

FIGURE 3-1 continued

18001024

***THIS PAGE INTENTIONALLY LEFT BLANK***

18001024

## CAB DOOR ADJUSTMENT

See [Figure 3-2](#) for the following procedure.

### General

The cab door damper prevents the cab door from slamming open or closed. This is especially critical when the cab is tilted at an angle other than horizontal.

### Closing Cab Door

To properly close the cab door:

1. Slide cab door to closed position, **but don't latch it**. This releases hydraulic pressure in damper.
2. Open cab door approximately 9 in (22 cm).
3. Slide cab door fully closed and latch.

### Damper Adjustment

See [Figure 3-2](#) for the following procedure.

1. Adjust cab tilt to level position.
2. Remove pin (3).
3. Swing damper (1) with rod end (4) away from cab door (6).
4. **Pull piston rod (2) out to fully extended position.**
  - a. While pulling on rod (2), turn it **clockwise** (looking at rod end) approximately four full turns until it stops. This is **maximum** damper pressure setting.
  - b. While pulling on rod (2), turn it **counterclockwise** (looking at rod end) approximately four full turns from maximum to **minimum** damper pressure setting. **This is pressure setting that is recommended.**
5. Reconnect rod end (4) to cab door (6).

**NOTE:** It may take several trial and error adjustments to obtain desired damping.

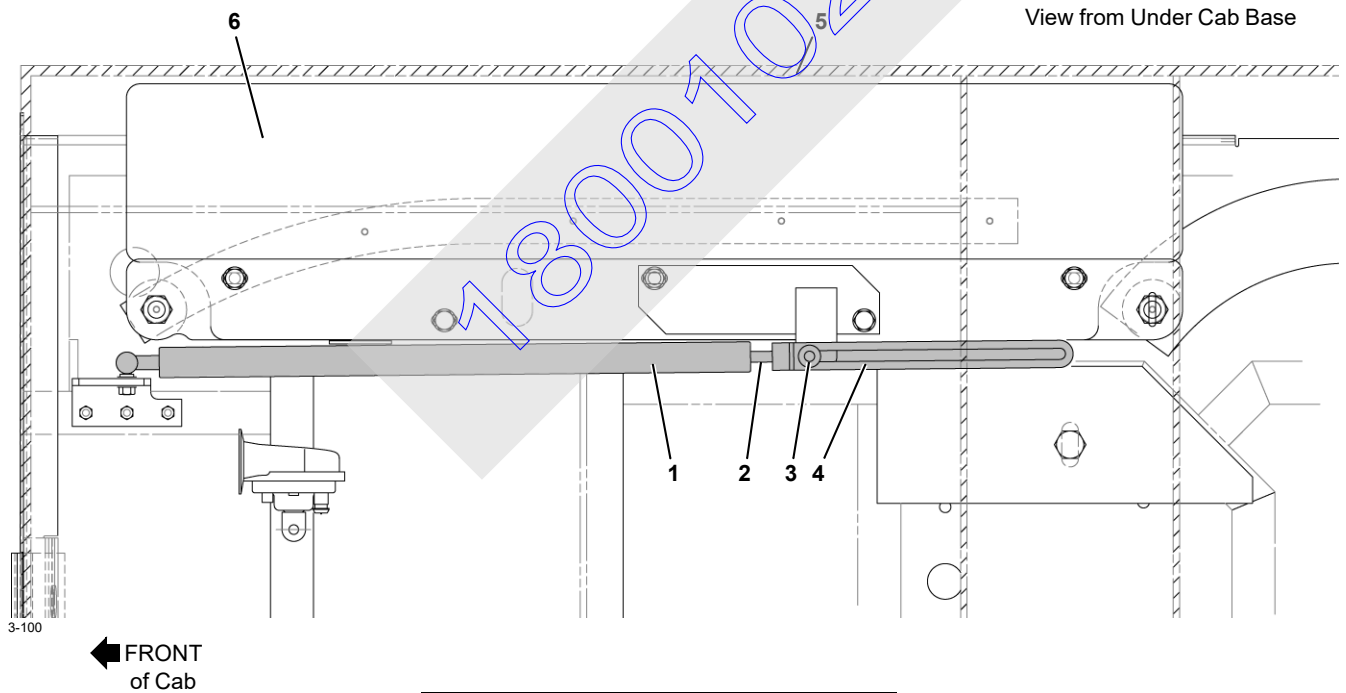

Item	Description
1	Damper
2	Piston Rod
3	Pin with Washers and Cotter Pins
4	Rod End
5	Bottom of Cab
6	Bottom of Sliding Door – CLOSED

FIGURE 3-2

## FRONT WINDOW OPERATION

See [Figure 3-3](#) for the following procedure.

### Closing Window

Rotate window latch handle DOWN to position shown in View A.

### Opening Window For Ventilation

Rotate window latch handle UP to position shown in View B. Window can be swung open approximately 3 in (76 mm) for ventilation.

### Opening Window For Emergency Exit

Pull out both quick-release pins at latch handle. Remove both knobs at top of window (View C). Push window out to allow emergency exit from cab.

## CRANE ORIENTATION

The terms right, left, front, and rear used in this section correspond to the operator's right, left, front, and rear sides when seated in the operator's cab with the front of the carbody to the operator's front. The carbody and crawler controls are mounted on the front of the carbody.

## OPERATING CONTROLS

The purpose of the following instructions is to familiarize qualified operators with the location and function of standard and optional operating controls for this crane. This section also contains safety information and a description of operation for each crane function.

Depending on the options your crane is equipped with, some controls identified in this section will not apply.



### WARNING

#### Prevent death or serious injury to personnel!

Read and thoroughly understand instructions in this section, Section 2, and in Capacity Chart Manual.

Contact your Manitowoc dealer for assistance if any operating procedure is not clearly understood.

## DISPLAY LANGUAGE

The language that is displayed on Rated Capacity Indicator/Limiter (C1) and Digital Display (D4) can be changed. See the Rated Capacity Indicator/Limiter Manual for instructions.

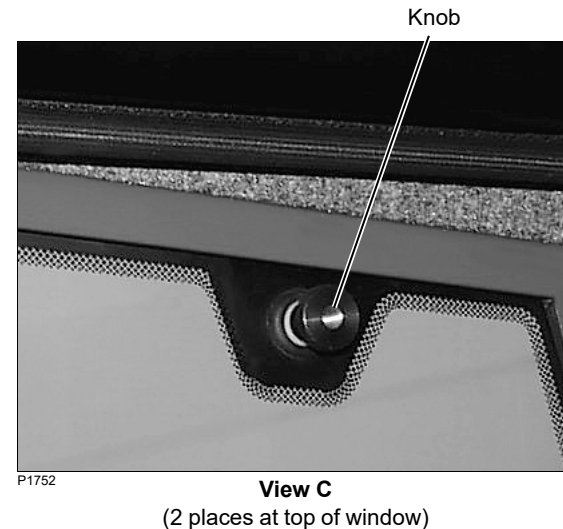
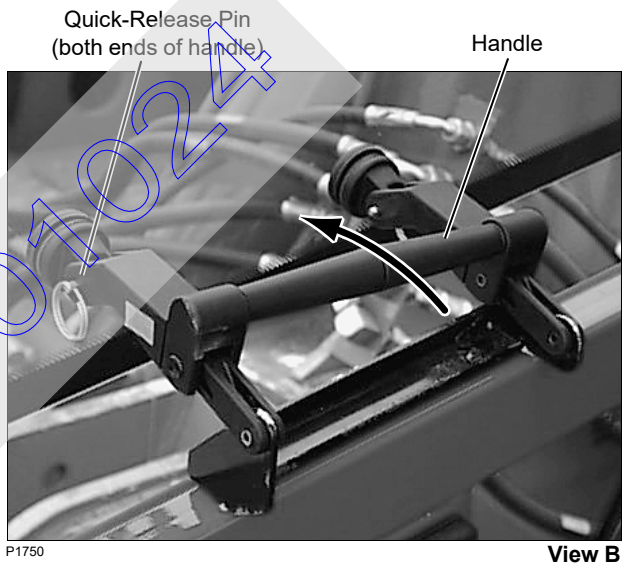
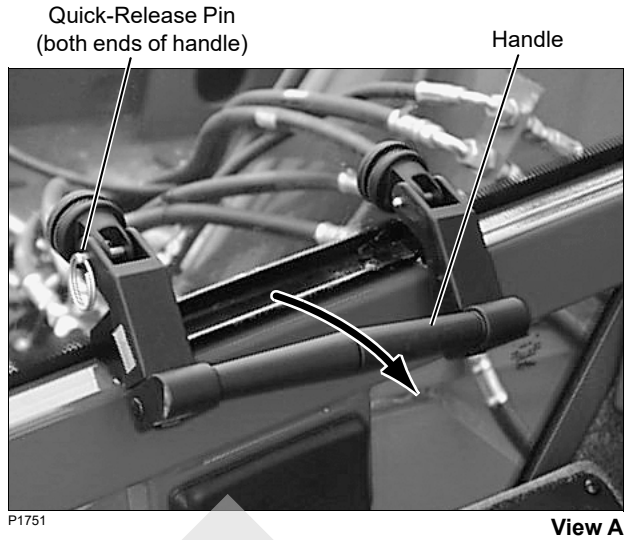

View C  
(2 places at top of window)

FIGURE 3-3

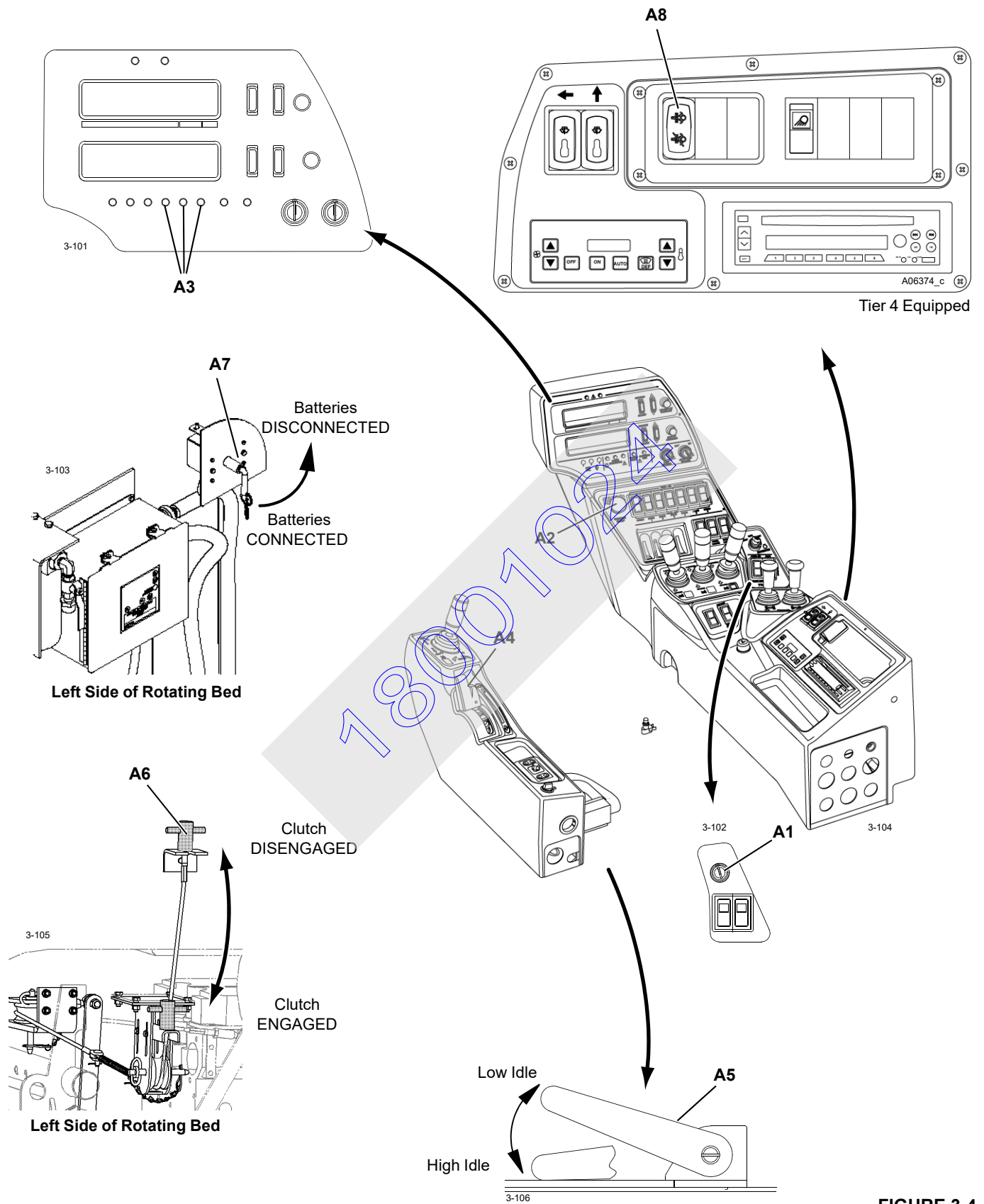

FIGURE 3-4

## CONTROLS IDENTIFICATION AND FUNCTION



### WARNING

#### Unauthorized Startup!

Always STOP engine and remove key before leaving crane unattended. This practice will prevent unauthorized personnel from operating crane.

## A – Engine Controls

See [Figure 3-4](#) for the following controls.

### A1. Engine Stop/Run/Start Switch

Insert key.

Turn CLOCKWISE to RUN position to turn on crane electrical system and digital display.

Turn fully CLOCKWISE to START engine. *RELEASE to RUN position as soon as engine starts.*

Rotate COUNTERCLOCKWISE to STOP engine and turn off crane's electric system.

**NOTE:** Stopping the engine in an emergency causes all brakes to apply and any functions being operated to stop — *beware that functions stop abruptly.*

The engine is equipped with an automatically controlled ether starting unit to aid in startup during cold weather.

### A2. Engine Stop Switch

Push knob DOWN to STOP engine in an emergency. Stopping the engine in an emergency causes all brakes to apply and any functions being operated to stop — *beware that functions stop abruptly.*

**NOTE:** This knob must be pulled up before the engine can be restarted.

### A3. Engine Diagnostics Lights

See Engine Diagnostics in this section for a description of each light and the engine diagnostic faults.

### A4. Engine Hand Throttle

Pull handle BACK to INCREASE engine speed.

Push handle FORWARD to DECREASE engine speed.

**NOTE:** The selected engine speed is maintained when the handle is released.

Speed of the crane functions depends on engine speed and on how far the control handles are moved in either direction from off.

Engine speed must be fast enough to provide sufficient power for the work being done. *Engine can stall under load if engine speed is too slow.*

### A5. Engine Foot Throttle

PRESS pedal to INCREASE engine speed above the hand throttle setting.

RELEASE pedal to DECREASE engine speed to idle or to the hand throttle setting.

### A6. Engine Clutch Handle

Pull clutch handle OUT and UP to bracket on crane to DISENGAGE clutch.

Push clutch handle IN and DOWN to bracket on engine to ENGAGE clutch.

### A7. Battery Disconnect Switch

Turn handle CLOCKWISE to CONNECT battery circuit.

Turn handle COUNTERCLOCKWISE to DISCONNECT battery circuit for the following reasons:

- When servicing crane's electrical control system
- If desired, to prevent batteries from discharging when the crane is stored for extended periods of time
- If desired, to prevent crane from being started by unauthorized personnel

The handle can be removed when the batteries are disconnected to prevent unauthorized use.

## CAUTION

### Engine Damage!

To avoid possible engine fault codes and undesirable operation, make sure engine ignition switch has been off two minutes before disconnecting batteries.

Do not rely on this switch to protect crane's electronic systems when welding. Disconnect battery cables at batteries before welding.



**A8. DPF Switch (Tier 4 Equipped)**

**NOTE:** DPF = Diesel Particulate Filter (cranes equipped with Tier 4 engine).

The DPF switch is a three position switch. Top position is momentary. Center and bottom position are maintained.

CENTER position is for NORMAL engine operation. Regeneration of the DPF will occur automatically.

Press TOP of rocker to START manual stationary regeneration. Release switch back to center position. Cummins ECM will control a DPF regeneration if necessary. It is normal for the DPF High Temperature lamp to illuminate.

Perform a manual stationary regeneration **only** if indicated by the DPF diagnostic in the Tier 4 Engine Diagnostics —

Cummins QSX15 Tier 4, (see DPF Condition (Tier 4) for details).

**NOTE:** A guard over the top of the rocker prevents accidental manual regeneration of the DPF.

Press BOTTOM of rocker to INHIBIT active regeneration. The amber LED in the rocker will glow.

Use INHIBIT only for special circumstances where it is desirable to disable active regeneration. Prolonged engine operation with INHIBIT on will cause the DPF to fill with soot. Too much soot could cause the engine to stop. If that occurs it will be necessary to clean the DPF before the engine can be restarted.

See Engine Manufacturer's Manual for additional information regarding stationary regeneration and DPF inhibit operating instructions.

18001024

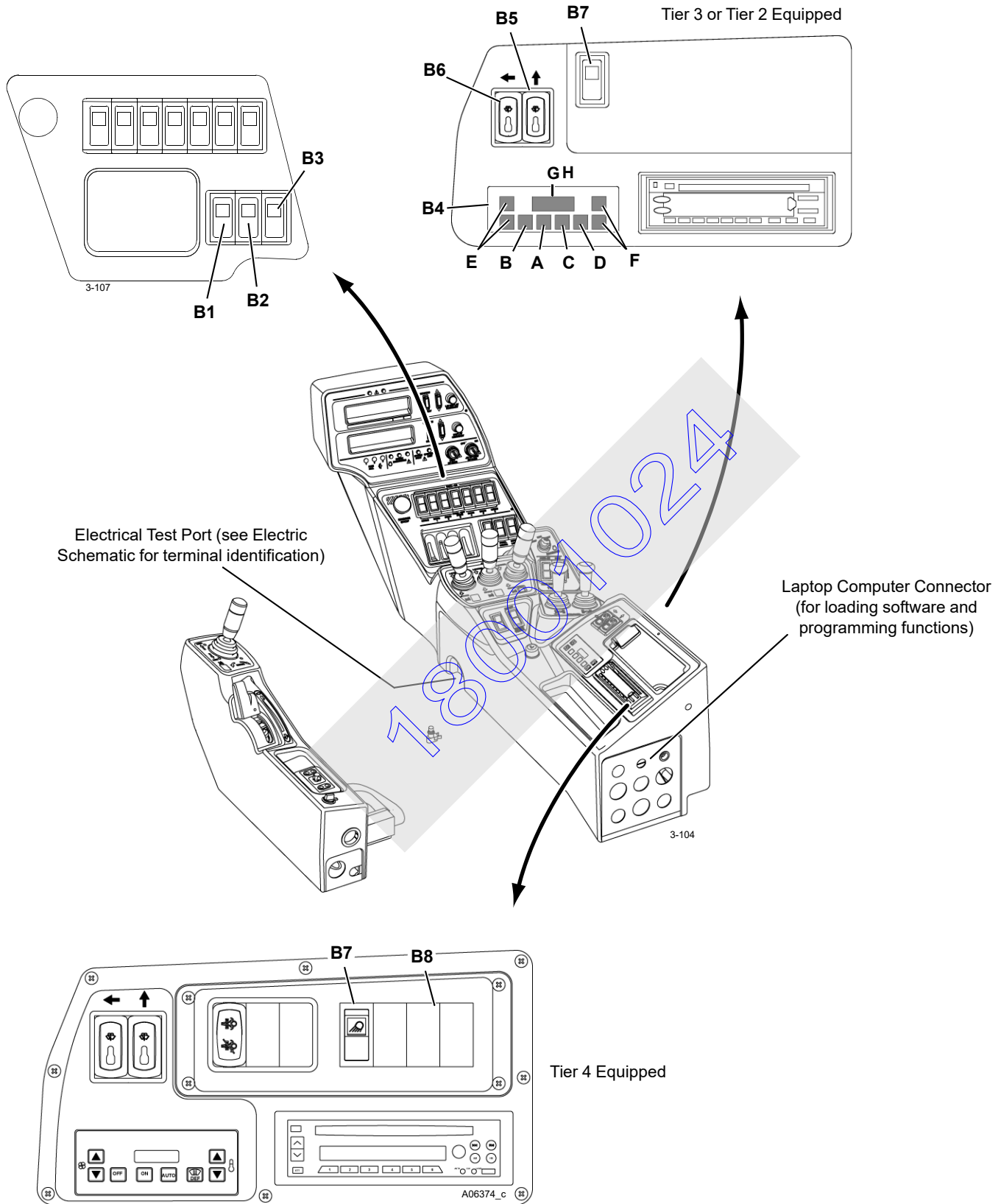

FIGURE 3-5

## B – Accessory Controls

See [Figure 3-5](#) for the following controls.

### B1. Cab Tilt Switch

PRESS and hold TOP of rocker to RAISE front of cab.

CENTER rocker to LOCK cab in position

PRESS and hold BOTTOM of rocker to LOWER front of cab.



### WARNING

#### Moving Cab Hazard!

Warn personnel to stand clear of operator's cab while tilting.

- Personnel can lose balance and fall.
- Personnel can be crushed between cab and railing.

#### Pinch Point Hazard!

To prevent injury from moving cab door:

- Do not open cab door while cab is tilted up. Door will spring back with considerable force.
- Always open and close cab door when cab is level.

See cab door adjustment in this section.

### B2. Panel Lights Switch

Press TOP of rocker to turn ON panel lights.

Press BOTTOM of rocker to TURN OFF panel lights.

### B3. Dome Light Switch

Press TOP of rocker to TURN on dome light.

Press BOTTOM of rocker to TURN OFF dome light.

### B4. Climate Control

Provides cab temperature control from 55–95°F (13–35°C).

- ON—Depress to turn on climate control system. The LED will illuminate and display the current temperature setting.
- OFF—Depress to turn off climate control system.
- AUTO—Depress to place system in fully automatic temperature control mode, to include fan speed. The system will adjust blower fan speed to the lowest setting necessary to maintain the selected

cab temperature. A panel indicator light illuminates when this mode is on.

- DEF (defrost)—Depress to energize the A/C system to allow for rapid de-humidification of cab. A panel indicator light illuminates when this mode is on.
- FAN UP/DOWN—Overrides AUTO mode. Depress to increment fan speed up or down in 11 steps. The LED indicates the setting as a percent between HI and LO. The selected fan speed is maintained until changed or the AUTO mode is turned on.
- TEMPERATURE UP/DOWN—Depress to raise or lower the temperature setting. The system maintains the cab temperature as close as possible to the selected temperature.

To change the display temperature from Fahrenheit to Celsius or back, depress TEMPERATURE UP/DOWN buttons simultaneously.

- LED
- FAULT CODES—To display fault codes, press ON button three times. Any active fault codes are shown on the LED.

Displayed fault codes are:

- E00 — No Faults
- E01 — Cab Sensor Shorted
- E02 — Cab Sensor Open
- E03 — Evaporator Probe Shorted
- E04 — Evaporator Probe Open
- E09 — Water Valve Shorted
- E10 — Water Valve Open

### B5. Overhead Windshield Wiper Switch

### B6. Front Windshield Wiper and Washer Switch

Each switch has several positions:

- Down — OFF
- Middle — 6 INTERMITTENT positions depending how far toggle is moved
- Up — HIGH speed

PRESS and hold front windshield wiper switch to SPRAY washer fluid on front windshield.

The windshield washer tank is mounted on the right side of the cab support. Fill the tank with a quality brand washing solution that *will not freeze during cold weather*.

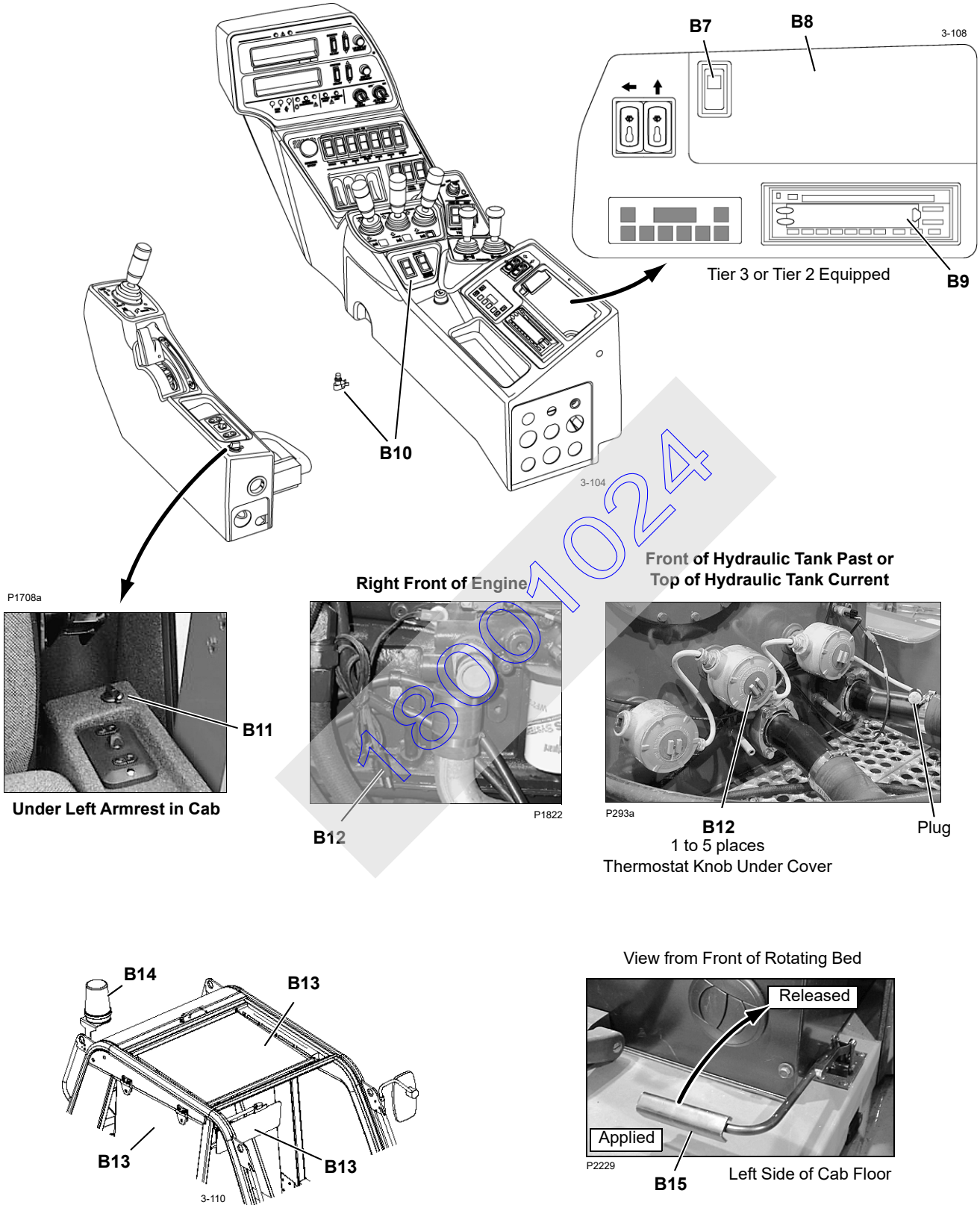

FIGURE 3-6

See [Figure 3-6](#) for the remaining controls.

### **B7. Crane Work Lights Switch**

This switch controls four optional work lights mounted on the crane cab, rotating bed, and boom butt.

Press TOP of rocker to TURN ON work lights.

Press BOTTOM of rocker to TURN OFF work lights.

### **B8. Accessory Control Panel**

This panel contains customer supplied accessory controls.

### **B9. Radio/CD Player**

See manufacturer's instructions.

### **B10. Horn Switches**

Two horn switches are provided: one mounted on right hand console and one mounted on right front side of cab floor. Use either horn *when necessary to warn or signal personnel while crane is being operated or serviced.*

On right console, PRESS and hold bottom of rocker to turn ON horn.

RELEASE rocker to turn OFF horn.

On right front side of cab floor, PRESS and hold down foot switch with right foot to turn horn ON.

RELEASE right foot from switch to turn horn OFF.

### **B11. 12V Power Supply Receptacle**

Provided for operating and charging a 12V cell phone or other appliance.

### **B12. Machinery Heaters**

The hydraulic tank has one (current) or three to five (past) thermostatically controlled heaters (120 V or 240 V) designed to keep the oil temperature 30°F (17°C) warmer than the ambient temperature. Each thermostat is preset to 100°F (38°C).

To aid engine startup in cold weather, plug in the heaters at shutdown (unplug the heaters at startup). The engine has a 1,500 watt coolant block heater (120 volts).

### **B13. Tinted Visor and Shade**

A visor is provided for the front window and shades are provided for the roof and side windows. Position the visor and shades as desired to shade sunlight.

### **B14. Cab RCL Rotating Beacon**

This amber rotating beacon is mounted on top of operator's cab. The beacon rotates with a flashing amber light and alarm whenever the RCL system is ON and the load weight or radius is near an overload condition.

### **B15. Cab Door Brake**

Manual handle for locking cab door in any position. Push handle down to apply and pull up to release.

### **B16. Anemometer**

NOT SHOWN. See manufacturer's instructions.

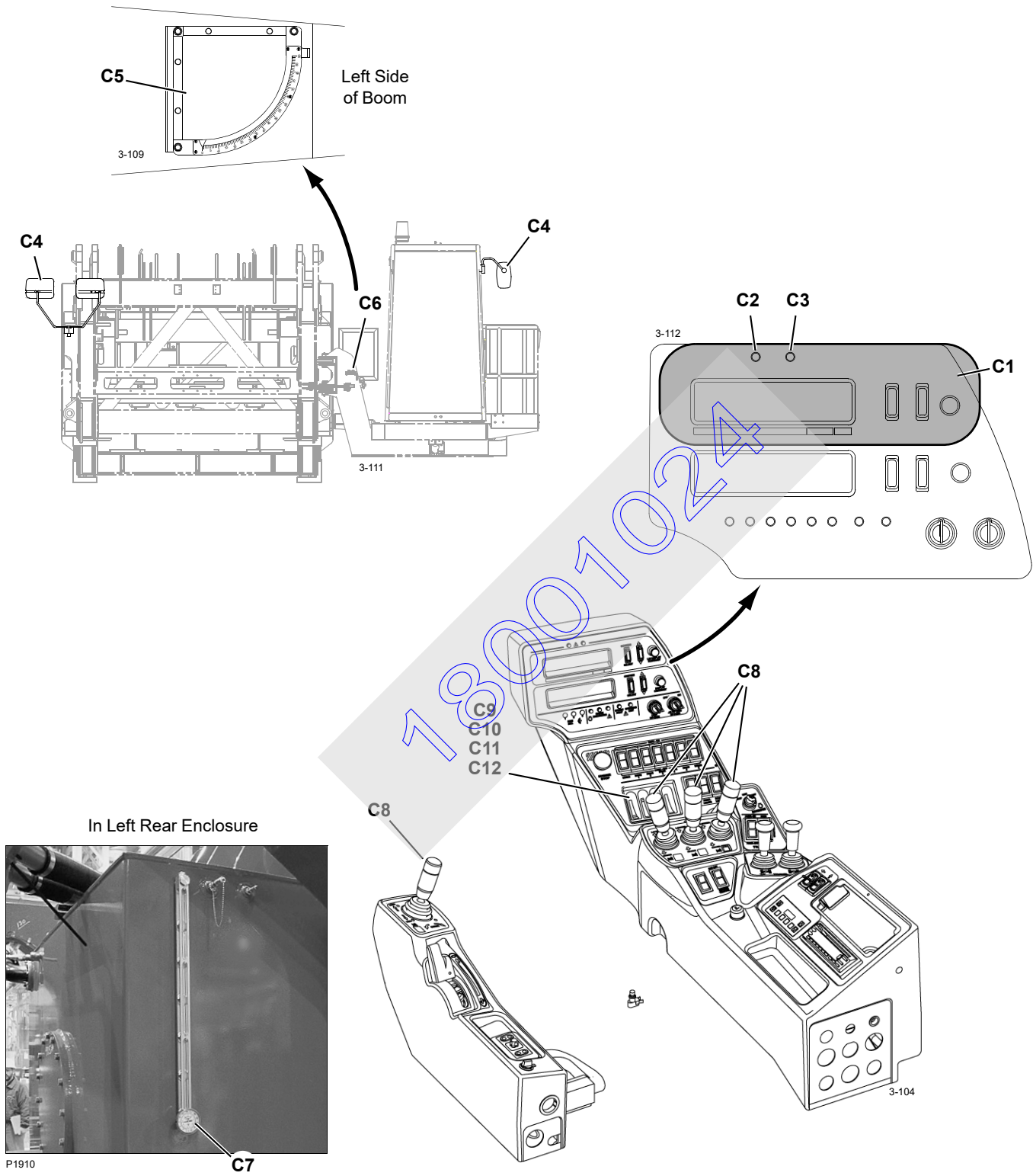

FIGURE 3-7



## C – Indicators

See [Figure 3-7](#) for the following indicators.

### C1. RCL (Rated Capacity Indicator/Limiter) Controls

See RCL Manual for operation and calibration instructions.

### C2. System Fault Alert

Glows RED and a beeper comes ON to alert operator that a system fault exists (fault automatically appears on digital display). See Digital Display Readings in this section for a list of system faults, causes, responses, and corrective actions.

### C3. Operating Limit Alert

Glows YELLOW and a buzzer comes ON to alert operator that an operating limit has been reached (limit automatically appears on digital display). See Digital Display Readings in this section for a list of operating limits, function responses, and corrective actions.

### C4. Rear View Mirrors

Adjustable rear view mirrors on operator's cab and rotating bed allow operator to view rear of crane. Mirrors must be rotated inward for shipping.

### C5. Boom Angle Indicator

Shows angle of the boom in degrees above horizontal. The boom angle can also be viewed on the digital display screen.

### **WARNING** Overload Hazard!

In all cases, radius must govern capacity.

Use boom angle indicator only as a guide to position boom near angle corresponding to radius for given load.

Exceeding radius given in capacity chart can result in tipping or structural damage.

### C6. Level

Indicates crane levelness from front to rear and from side to side as shown in [Figure 3-8](#). The level is mounted on cab support and is visible through right side window in operator's cab.

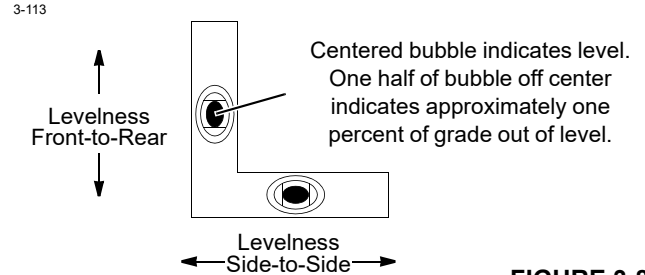

FIGURE 3-8

### **WARNING** Tipping Hazard!

Unless otherwise specified on capacity chart, all crane operations must be performed with crane *level* to within one percent of grade in all directions – 1 ft in 100 ft (0,3 m in 30 m); otherwise, crane could tip.

### C7. Hydraulic Level and Temperature Gauge

Indicates hydraulic tank fluid level and temperature of oil in hydraulic tank.

### **CAUTION** Pump Damage!

Do not operate crane functions until hydraulic oil temperature is at least 60°F (16°C).

### C8. Drum Rotation Indicators

Pin-type actuators are located under all drum handle covers. They move UP and DOWN to signal operator, by feel, that corresponding drum is turning. Indicator movement corresponds to drum speed.

### C9. Fuel Level

Indicates amount of fuel left in fuel tank.

### C10. Engine Coolant Temperature

Indicates coolant temperature in engine cooling system. See engine manual for operating specifications.

### C11. Engine Oil Pressure

Indicates oil pressure in engine lubricating system. See engine manual for operating specifications.

### C12. Battery Voltage

Indicates condition of battery charging system.



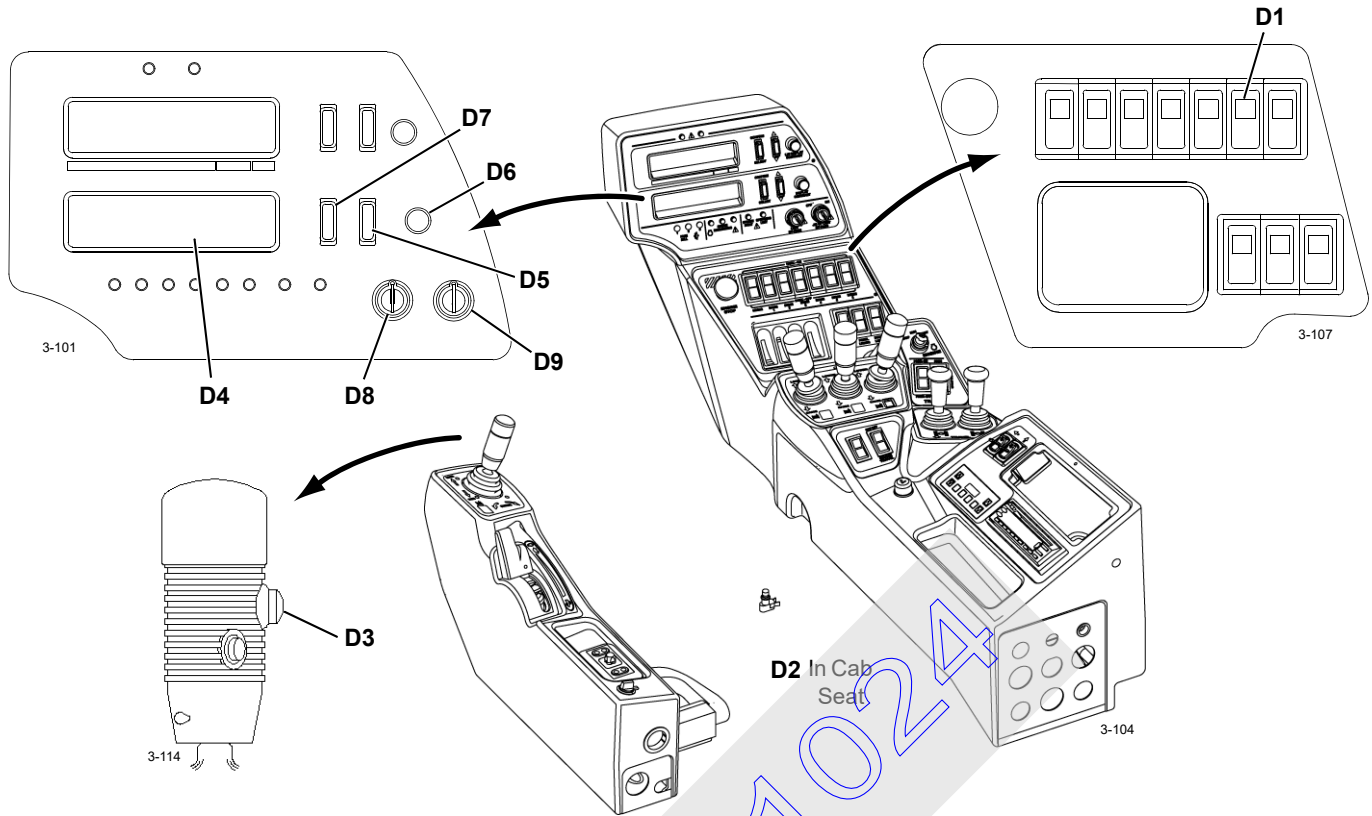

FIGURE 3-9

**D – Special Controls**

See [Figure 3-9](#) for the following controls.

**D1. Drum 5 (Mast Hoist) Park Switch**

Mast hoist system can only be operated in the crane setup mode using hoist handle **D**.

Press TOP of rocker to TURN ON mast hoist park. With park on, the mast hoist system is inoperable, the park brake is applied, and the Drum 5 pawl is engaged.

Press BOTTOM of rocker to TURN OFF mast hoist park. With park off, the mast hoist system is operable, the park brake is applied and released in conjunction with handle movement, and the Drum 5 pawl is disengaged.

**D2. Seat Switch**

Prevents crane from being operated until operator is seated.

**D3. Dead-Man Switch (Optional)**

The dead man switch (red button) is mounted on the front of control handle **A**. It prevents the crane functions from being operated until operator depresses and holds the switch in.

If the switch is released when operating, all crane functions (travel, swing, boom hoist, and all load drums) come to a controlled stop and the brakes apply. Additionally, engine speed decreases to idle.

**D4. Digital Display**

Allows operator to monitor three groups of crane information: operating conditions, operating limits, and system faults. See Digital Display Readings in this section for information which can be displayed.

**D5. Scroll Selector**

Press TOP or BOTTOM of rocker to scroll UP or DOWN through display readings. Release selector when desired information is displayed.

**D6. Digital Display Contrast Switch**

Turn in either direction to adjust brightness of display.

**D7. Crane Mode Confirm/Select Switch**



**WARNING**  
**Moving Load Hazard!**

Operator shall select and confirm proper operating mode before operating.

Unexpected drum motion or improper limit responses can result if wrong mode is selected.

Press BOTTOM of rocker to SELECT crane mode.

CRANE MODE will appear on the first line of the digital display. The available crane modes will then scroll by (one to two seconds apart) on the next line of the digital display.

Press TOP of rocker to CONFIRM desired crane mode when it appears on digital display.

**NOTE:** To check the crane mode in effect at any time, press top of rocker (CONFIRM). The current mode will appear on the digital display.

The crane mode in effect when the engine is stopped remains in memory. At startup, the crane mode in effect must be confirmed or another mode must be selected and confirmed. The load drums and boom hoist are not operable until this step is performed. The system fault alert comes on and CONFIRM MODE appears on the digital display if operation is attempted.

See [Figure 3-10](#) for drum identification.

The following crane modes are available:

- STANDARD

Use this mode for all normal load handling operations.



### WARNING

#### Falling Boom Hazard!

Crane setup and setup remote modes are provided for crane assembly and disassembly purposes only.

**Do not use crane setup or setup remote mode for normal load handling operations.**

Read and follow instructions in Crane Assembly and Disassembly Guide in Section 4.

- CRANE SETUP

This mode enables Drum 5 (mast hoist) system to operate with control handle **D** ([Figure 3-10](#)) during crane assembly and disassembly. This mode does not turn on the hand-held radio remote control (see Setup Remote Mode).

- SETUP REMOTE

This mode turns on the hand-held radio remote control and the crane setup mode.

When this mode is on, \*R appears in the crane mode line of the digital display, as follows:

Crane Mode – STANDARD ON \*R

- LUFFING JIB

Same as standard except the Drum 6 (luffing jib hoist) is operable with control handle **A** ([Figure 3-10](#)) and the luffing jib limits are turned on. See Luffing Jib Manual for raising and lowering instructions when equipped with luffing jib attachment.

- LUFFING JIB SETUP

For crane Serial Number 18001082 and newer, this mode allows the limits listed in [Table 3-3](#) to be bypassed with Limit Bypass Switch (D5). When this mode is on, LS appears in the crane mode line of the digital display, as follows:

Crane Mode – LUFFING JIB ON LS

To bypass the limits listed in [Table 3-3](#) for luffing jib setup, proceed as follows:

- Select and confirm luffing jib setup mode.
- Rotate limit bypass switch (F5) clockwise and release. The limits will remain bypassed for 10 seconds.
- Move the desired control handle (luffing hoist, boom hoist, load drum) in the required direction. The limits will remain bypassed for as long as the handle is moved in either direction.
- The limits will remain bypassed for 10 seconds after the control handle(s) is returned to neutral (off).

- LUFFING JIB STOP

Use this mode to extend and retract the jib stop positioning cylinders when raising and lowering the 79A luffing jib. See Section 3 and 4 of Luffing Jib Operator Manual for instructions.

• TANDEM

In tandem mode, load Drums 1 and 2 are controlled at the same time by control handle **B** (Figure 3-10).

Drum speeds are synchronized automatically to keep the load block level.

• MAX-ER

See Section 3 of MAX-ER Operator Manual for MAX-ER operating instructions.

• RIG WINCH

See Section 4 in this manual for rigging winch operating instructions.

See Figure 3-9 for the following controls.

**D8. Limit Bypass Switch**

This switch bypasses the limits identified in Table 3-2 or Table 3-3.



**WARNING**

When bypassing a limit, carefully follow instructions under Limit Devices topic in this section.

Insert key. Turn CLOCKWISE and HOLD to BYPASS reached operating limits. This position allows functions to be operated beyond the limits.

RELEASE to ENABLE operating limits. This position allows limits to stop functions in the normal manner. **Key must be in this position for normal operation. Otherwise, structural damage can occur.**

Remove key to prevent unauthorized operation.

**D9. Not Used**

If equipped, this switch has no function.

**Table 3-2 Bypassable Limit Identification** — Prior to Crane Serial Number 18001082

Limit	Limit Bypass Switch (D8) (momentary key switch)	
	Non-CE <sup>1</sup>	CE <sup>1</sup>
PAST PRODUCTION WITH QUADRANT STYLE JIB STOP		
MAX UP 1 (Boom)	Yes or No <sup>2</sup>	No
BLOCK UP (each drum)	Yes	Yes
MIN BAIL (each drum)	Yes	Yes
LOAD MOMENT (RCL/RCI)	Yes	Yes
MAX UP 1 (Luffing Jib)	Yes	Yes
MAX UP 2 (Luffing Jib) <sup>3</sup>	Yes	Yes
MAX DOWN	No	No
CURRENT PRODUCTION WITHOUT QUADRANT STYLE JIB STOP		
MAX UP 1 (Boom)	Yes or No <sup>2</sup>	No
BLOCK UP (each drum)	Yes	Yes
MIN BAIL (each drum)	Yes	Yes
LOAD MOMENT (RCL/RCI)	Yes	Yes
MAX UP 1 (Luffing Jib)	Yes	Yes
MAX UP 2 (Luffing Jib) <sup>3</sup>	Yes	Yes
MAX DOWN 1 (Luffing Jib)	Yes	Yes
MAX DOWN 2 (Luffing Jib)	No	No

<sup>1</sup> CE = Cranes that comply with European requirements.

<sup>2</sup> The boom up limit cannot be bypassed on current production cranes. To determine if the boom up limit can be bypassed on your crane, perform the test given on page 3-32 in this section.

<sup>3</sup> Only when boom is below 50°

**Table 3-3 Bypassable Limit Identification** — Crane Serial Number 18001082 and Newer

Limit	Limit Bypass Switch (D8) (momentary key switch)		Limit Bypass Switch (D8) (momentary key switch) Luffing Jib Setup Mode On <sup>1</sup>		External Override Switch <sup>2</sup>
	Non-CE <sup>3</sup>	CE <sup>3</sup>	Non-CE <sup>3</sup>	CE <sup>3</sup>	CE <sup>3</sup>
MAX UP 1 (Boom)	No	No	No	No	No
BLOCK UP (each drum)	Yes	Yes	Yes	Yes	No
MIN BAIL (each drum)	Yes	Yes	No	No	No
LOAD MOMENT (RCL/RCI)	Yes	Yes <sup>4</sup>	No	No	Yes <sup>5</sup>
MAX UP 1 (Luffing Jib)	Yes	No	Yes	Yes	No
MAX UP 2 (Luffing Jib)	Yes <sup>6</sup>	No	Yes <sup>6</sup>	Yes <sup>6</sup>	No
MAX DOWN 1 (Luffing Jib)	Yes	No	Yes	Yes	No
MAX DOWN 2 (Luffing Jib)	Yes	No	Yes	No	No
MAST TOO FAR FORWARD	Yes	Yes	No	No	No

<sup>1</sup> Use only for rigging.

<sup>2</sup> See Rated Capacity Indicator/Limiter Operation Manual.

<sup>3</sup> CE = Cranes that comply with 2010 European requirements.

<sup>4</sup> Only while operating between 100% and 110% rated capacity. The speed of the crane functions is limited to 15% of their maximum speed for movements that increase load.

<sup>5</sup> The speed of the crane functions is limited to 15% of their maximum speed for movements that increase load.

<sup>6</sup> Only when boom is below 50°

18001024

### DRUM AND HANDLE IDENTIFICATION

Item	Description
1	Main Hoist 1 (in boom insert)
2	Main Hoist 2 (in boom butt)
3	Whip Line Hoist
4	Boom Hoist (in mast butt)
5	Mast Hoist
6	Luffing Jib Hoist (in boom butt)
7	Rigging Winch (controlled by radio remote switches)

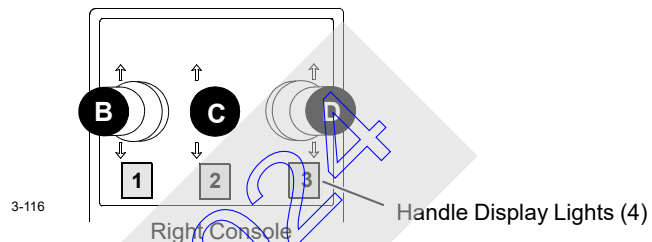
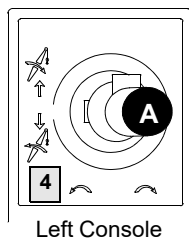
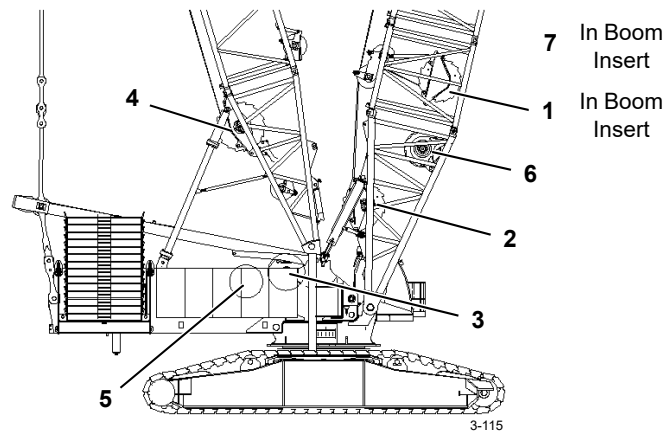

Mode Options (NOTE 1)	HANDLE A Controls Drum	HANDLE B Controls Drum	HANDLE C Controls Drum	HANDLE D Controls Drum
Standard (NOTE 2)	4 - Boom Hoist	1 - Main Hoist 1	2 - Main Hoist 2	3 - Whip Line Hoist
Setup (NOTE 2 and NOTE 3)	4 - Boom Hoist	3 - Whip Line Hoist	2 - Main Hoist 2	5 - Mast Hoist (NOTE 4)
Luffing Jib (NOTE 2)	6 - Luffing Jib Hoist	1 - Main Hoist 1	2 - Main Hoist 2 3 - Whip Line Hoist	4 - Boom Hoist 3 - Whip Line Hoist
Tandem Drum (NOTE 2)	4 - Boom Hoist	1 - Main Hoist 1	2 - Main Hoist 2	3 - Whip Line Hoist
Rigging Winch (NOTE 5)	7 - Rigging Winch	1 - Main Hoist 1	2 - Main Hoist 2	3 - Whip Line Hoist 6 - Luffing Jib Hoist

- NOTE 1:** See handle display light to determine what drum is controlled by what handle.
- NOTE 2:** Main Hoist (Drum 1) and Whip Hoist (Drum 3) are both controlled by same pump. Only one drum can be operated at a time. The drum operated first has priority over the other drum. For cranes with software version M00200R.0SP or newer, while in Luffing Jib mode only, Whip Hoist (Drum 3) will be assigned to Handle C and Boom Hoist (Drum 4) will be assigned to Handle D when Main Hoist (Drum 2) is parked and Whip Hoist (Drum 3) is NOT parked.
- NOTE 3:** Main Hoist (Drum 2) and Mast Hoist (Drum 5) are both controlled by same pump. Only one drum can be operated at a time.
- NOTE 4:** Mast Hoist 5 can be operated only in setup mode.
- NOTE 5:** See Section 4 of this manual for Rigging Winch Operation.

FIGURE 3-10

*THIS PAGE INTENTIONALLY LEFT BLANK*

18001024

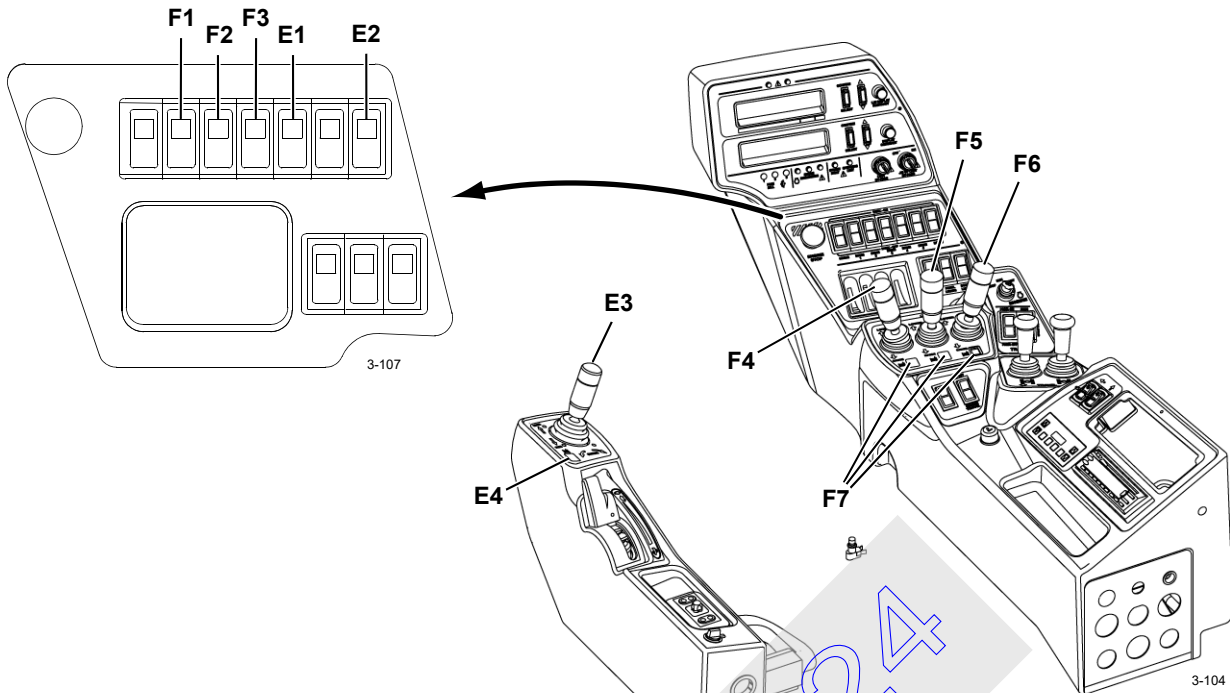

FIGURE 3-11

**E – Boom/Luffing Hoist Controls**

See [Figure 3-11](#) for the following controls.

See [Figure 3-10](#) for drum identification.

The boom or luffing hoist and swing are control by a dual-axis handle (**A**) on left hand console that allows both functions to be operated at the same time with one handle.

The boom hoist has a spring-applied, hydraulically-released disc brake on each end of the drum shaft. The luffing jib hoist drum has a spring-applied, hydraulically-released disc brake on one end of drum shaft.

- Selected hoist park brake is released automatically when handle **A** is moved in either direction from off.
- Selected hoist park brake is applied automatically when handle **A** is moved to off, the engine is stopped, applicable operating limits are reached, system faults occur, or park brake is turned on.

**E1. Drum 4 (Boom Hoist) Park Switch**

Press TOP of rocker to TURN ON boom hoist park. With park on, boom hoist handle is inoperable, drum park brake is applied, and Drum 4 pawl is engaged.

Press BOTTOM of rocker to TURN OFF boom hoist park. With park off, boom hoist handle is operable, drum park

brake is applied and released with handle **A** movement, and Drum 4 pawl is disengaged.

**E2. Drum 6 (Luffing Jib Hoist) Park Switch**

Press TOP of rocker to TURN ON Drum 6 park. With park on, the luffing jib system is inoperable, the park brake is applied, and the drum 6 pawl is engaged.

Press BOTTOM of rocker to TURN OFF Drum 6 park. With park off, the luffing jib system is operable, the park brake is applied and released with handle **A** movement, and Drum 6 pawl is disengaged.

**E3. Boom/Luffing Hoist Handle A**

Pull handle **A** BACK to RAISE selected boom or luffing hoist. The park brake releases and speed increases in relation to handle movement.

Release handle **A** to CENTER to STOP selected boom or luffing hoist. The park brake will apply.

Push handle **A** FORWARD to LOWER selected boom or luffing hoist. The park brake releases and speed increases in relation to handle movement.

**E4. Boom/Luffing Hoist Handle Display Light**

When Standard mode is selected, Drum 4 appears in handle display next to handle **A**, to indicate boom hoist is active.



When Luffing mode is selected, drum 6 appears in handle display next to handle **A** to indicate luffing jib hoist is active. Drum 4 appears next to handle **D** to indicate boom hoist is active.

## F – Load Drum Controls

See [Figure 3-11](#) for the following controls.

See [Figure 3-10](#) for drum identification.

Each load drum has a spring-applied, hydraulically-released disc brake on the motor end of the drum shaft. The main hoist 1 and 2 load drums have a motor/brake on each end of drum.

For FULL POWER operation:

- Corresponding park brake(s) is released automatically when control handle is moved in either direction from off.
- Corresponding park brake(s) is applied automatically when control handle is moved to off.

**NOTE:** All drum park brakes are applied automatically when the engine is stopped, applicable operating limits are reached or system faults occur, and when drum park is turned on.

### F1. Drum 1 (Main Hoist 1) Park Switch

### F2. Drum 2 (Main Hoist 2) Park Switch

### F3. Drum 3 (Whip Line Hoist) Park Switch

Press TOP of rocker to TURN ON corresponding drum park. With drum park on, control handle is inoperable, park brake is applied, and (if equipped) drum pawl is engaged.

Press BOTTOM of rocker to TURN OFF drum park. With drum park off, control handle is operable, park brake is applied and released with handle movement, and (if equipped) drum pawl is disengaged.

### F4. Control Handle B

### F5. Control Handle C

### F6. Control Handle D

Control handle **B** is the first single axis handle on right hand console that can be programmed to control either drum 1 (main hoist 1) or drum 3 (whip line hoist in Setup mode).

**NOTE:** See [Figure 3-10](#) for drum identification.

Control handle **C** is the middle single axis handle on right hand console that is programmed to control drum 2 (main hoist 2) or drum 3 (whip hoist, luffing jib mode only). For cranes with software version M00200R.0SP or newer, while in Luffing Jib Mode only, drum 3 (whip hoist) will be assigned to control handle **C** if drum 2 (main hoist) is parked and drum 3 (whip hoist) is *not* parked.

Control handle **D** is the last single axis handle on right hand console that is programmed to control drum 3 (whip line hoist) or drum 4 (boom hoist) in luffing mode or drum 5 (mast hoist) in setup mode.

**NOTE:** When drum 4 (boom hoist) is *not* parked, drum 4 is displayed behind handle and is available. When drum 4 (boom hoist) is parked, drum 3 is displayed behind handle and is available. For Cranes with software version M00200R.0SP or newer, while in Luffing Jib Mode only, drum 3 (whip hoist) will be assigned to control handle **C** and drum 4 (boom Hoist) will be assigned to control handle **D** if drum 2 (main hoist) is parked and drum 3 (whip hoist) is *not* parked.

1. Press BOTTOM of confirm/select rocker to SELECT standard crane mode.
2. Press BOTTOM of confirm/select rocker until standard mode is displayed on digital display.
3. Press TOP of confirm/select rocker to CONFIRM standard mode.

Pull selected handle BACK to HOIST load. Park brake releases and speed increases in relation to handle movement.

Release handle to CENTER to STOP load. The park brake will apply.

Push selected handle FORWARD to LOWER load. Park brake releases and speed increases in relation to handle movement.

### F7. Control Handle Display Lights

Control handle locations vary depending on crane mode or options selected. When standard mode is selected:

- Drum 1 appears in handle display next to handle **B**.
- Drum 2 appears in handle display next to handle **C**.
- Drum 3 appears in handle display next to handle **D**.

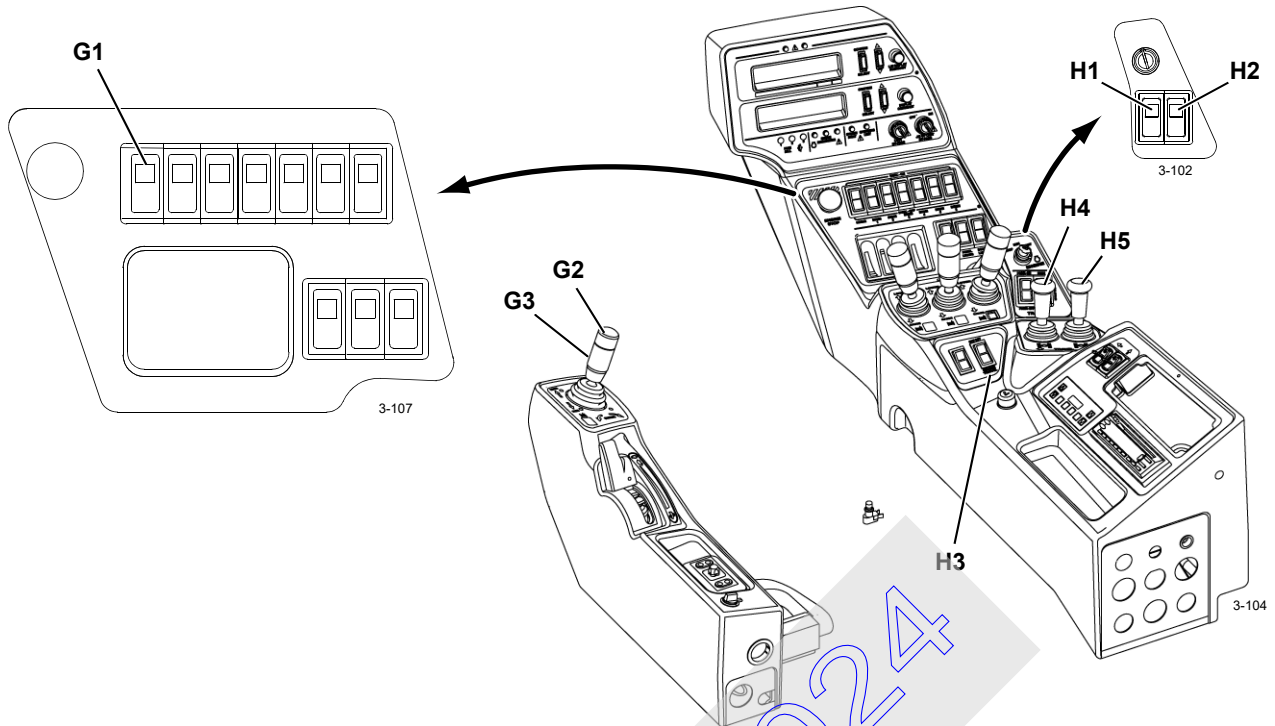

FIGURE 3-12

**G – Swing Controls**

See [Figure 3-12](#) for the following controls.

**NOTE:** Swing lock is not available on current production.

The swing drive has a spring-applied, hydraulically-released disc brake and swing lock for each swing motor.

- The swing brakes are released and the swing locks are disengaged during normal operation.
- The brakes apply automatically if power is lost, when the swing holding brake switch is activated, and when swing park is turned on.
- The swing locks are engaged when park is turned on.

The swing and travel alarm sounds to warn personnel when the upperworks is swung.

**G1. Swing Park Switch**

Press TOP of rocker to TURN ON swing park. With park on, the swing handle is inoperable, the swing brakes are applied, and the swing locks are engaged.

Press BOTTOM of rocker to TURN OFF swing park. With park off, the swing handle is operable, the swing brakes are released, and the swing lock is disengaged.

**G2. Swing Handle**

The dual-axis handle allows swing system and boom hoist or luffing jib to be operated at the same time with one handle.

Move handle to LEFT to SWING LEFT. Swing speed increases in relation to handle movement.

Move handle to RIGHT to SWING RIGHT. Swing speed increases in relation to handle movement.

Release handle to CENTER to STOP. Swing speed decreases to off and the upperworks slow to a stop. Move handle in opposite swing direction to stop the swing motion faster.

Press swing holding brake switch to hold the stopped upperworks in position.

**G3. Swing Holding Brake Switch**

Use the swing holding brake switch (black button on side of handle) to hold the upperworks in position for short periods of time during the operating cycle. The swing brake will apply and the swing handle will be inoperable while the switch is pressed.

PRESS button to APPLY swing holding brake.

RELEASE button to RELEASE swing holding brake.

**CAUTION**

**Swing Drive/Boom Damage!**

Do not apply swing holding brake or turn on swing park while swinging; brake will bring upperworks to an abrupt stop. This action could cause damage to boom from side loading or damage to swing drive from shock loading. Bring upperworks to smooth stop with swing handle and then apply swing holding brake or turn on swing park.

## H – Travel Controls

See [Figure 3-12](#) for the following controls.

The crawlers have spring-applied, hydraulically-released disc brakes.

- Both crawler brakes release when either crawler handle is moved in either direction from off.
- Both crawler brakes apply when both crawler handles are moved to off.
- Both crawler brakes apply to hold crane in position if power is lost for any reason.

The swing and travel alarm sounds to warn personnel when the crane is traveled.

### H1. Travel Park Switch

Press TOP of rocker to TURN ON travel park. With travel park on, the travel handles are inoperable and the park brakes are applied.

Press BOTTOM of rocker to TURN OFF travel park. With travel park off, the travel handles are operable and the park brakes are applied and released with crawler handle movement.

### H2. Travel Speed Selector

Press TOP of rocker to operate travel motors in HIGH speed. High speed operation provides the maximum available travel speed for traveling long distances.

Press BOTTOM end of rocker to operate travel motors in LOW speed. Low speed operation provides smoother starts and stops and more precise control of the travel motors than high speed.

In low speed, the travel motors operate at approximately 1/3 of high speed.

**NOTE:** It is okay to change travel speed while traveling:

The travel motors will shift immediately from high to low when low speed is selected.

The travel motors will not shift from low to high when high speed is selected until:

- Engine speed is at high idle.
- Hydraulic pressure is low enough to allow the motors to shift from low to high speed.

### H3. Travel Cruise Selector

The travel cruise selector allows the crawlers to be operated in either direction at a selected speed without the operator's hand on the crawler handles.

Move both crawler handles in either direction from off to select desired speed and direction of travel. Press top of rocker to turn ON travel cruise. Release crawler handles to off. Crawlers will continue to travel at selected speed and direction.

Slightly move either crawler handle in the opposite direction or press bottom of rocker to turn OFF travel cruise.

### H4. Left Crawler Handle

### H5. Right Crawler Handle

**NOTE:** The following directions of travel are with **front of upperworks and front of lowerworks facing same direction.**

- Operator's cab is at front of upperworks.
- Crawler motors are at rear of lowerworks.
- Crawler pin handles on carbody are at front of lowerworks.

**If front of upperworks and front of lowerworks face in opposite directions, crane will travel in the direction opposite handle movement.**

Push crawler handle FORWARD to travel FORWARD. The park brakes release and speed increases in relation to crawler handle movement.

Release crawler handle to CENTER to STOP traveling. The park brakes spring apply.

Pull crawler handle BACK to travel in REVERSE. The park brakes release and speed increases in relation to handle movement.

## J – Setup Controls



### WARNING

#### Death or Serious Injury!

Read and understand instructions in Crane Assembly and Disassembly in Section 4 before selecting setup mode or using setup controls.

See Remote Controls in this section for identification and operation of the remote controls used for crane assembly and disassembly.

## K – Limit Devices

See [Table 3-2](#) and [Table 3-3](#) to determine which limits can be bypassed.

**Max Up 1 (boom)**

Automatically stops the boom when it is raised to the preset maximum angle shown in the following table:

Max. Boom Angle	Attachment
83° <sup>1</sup>	#55-79A, #55, or 55A Boom without Luffing Jib
OR	
84° <sup>2</sup>	#55-79A, #55, or 55A Boom without Luffing Jib
<b>When boom up limit <i>can be bypassed.</i> *</b>	
85°	#44 or #79A Luffing Jib on 140-180 ft (42,7-54,9 m) of Boom
87°	#44 or #79A Luffing Jib on 200-340 ft (61,0 –103,6 m) of Boom
<b>When boom up limit <i>cannot be bypassed.</i> *</b>	
86°	#44 or #79A Luffing Jib on 140-180 ft (42,7-54,9 m) of Boom
88°	#44 or #79A Luffing Jib on 200-340 ft (61,0 -103,6 m) of Boom

\* To determine if the boom up limit on your crane can be bypassed or not, perform Bypass Limit Test given below.

- 1: Past cranes with 4-3/4 in (121 mm) long adjusting rod.
- 2: Current cranes with 4-1/2 in (114 mm) long adjusting rod.

The boom can be lowered after the limit is contacted.



**WARNING**  
**Falling Boom/Jib Hazard!**

If you bypass boom up limit for any reason, DO NOT allow physical boom stops to bottom out. Boom butt could be damaged, causing boom and jib to fall over backwards.

**Crush Hazard!**

Maintain constant communication between operator and assistant during following steps.

Stay clear of moving parts.

**LIMIT BYPASS TEST:** Perform the following test to determine if the boom up limit on your crane can be bypassed or not:

1. Lower the boom onto blocking at ground level.
2. Have an assistant push the boom stop rod in to trip the boom up limit switch open (see Section 4 of Service Manual supplied with crane).

3. Rotate limit bypass key (D5) to the bypass position and hold.
4. Try to boom up SLOWLY — do not raise the boom any higher than necessary to perform the test:
  - a. If the boom rises, your boom up limit can be bypassed.
  - b. If the boom does not rise, your boom up limit cannot be bypassed.
5. The test is complete: release the limit bypass key and the boom stop rod to the normal operating positions.

**Block Up**

Automatically stops the boom or luffing jib hoist from lowering and the load drums from hoisting if the load contacts a block-up limit switch.

The load on the corresponding drum can be lowered and the boom or luffing jib hoist can be raised after a block-up limit switch is contacted.

The appropriate limit bypass switch must be turned to the bypass position before a load can be hoisted above the limit.



**WARNING**  
**Two-Blocking Hazard!**

If it is necessary to hoist a load above block-up limit, do so slowly with extreme caution to prevent two-blocking.

Do not hoist load above minimum block clearance given in Range Diagram (see Capacity Chart Manual).

Do not use limit bypass switch to lower boom or luffing jib hoist after block-up limit is contacted; two-blocking could occur, causing load to fall.

**Luffing Jib UP Limits**

Two luffing jib up limits are provided:

- **MAX UP 1** (maximum working angle): automatically stops the luffing hoist when the boom to luffing jib angle is 168°. This is a programmed limit controlled by angle sensors on the boom and jib.

The limit bypass switch must be turned to the bypass position to allow the jib to be raised to MAX UP 2 limit.

- **MAX UP 2** (maximum angle): automatically stops the luffing hoist when the boom to luffing jib angle is 169 to 170.5°. This limit is controlled by a limit switch.

This limit can be bypassed with the limit bypass switch only when the attachment is lowered to ground (boom below 50°).

The luffing jib can be lowered after either limit is contacted.

**NOTE:** For Crane Serial Number 18001082 and newer meeting 2010 European Requirements, the luffing jib cannot be lowered after the jib maximum up 2 limit is contacted until the limit switch is reset. When the limit is contacted, the screen shown in [Figure 3-13](#) will appear on the digital display.

Once the screen appears, confirm it to reset the limit switch. The luffing jib can then be lowered.

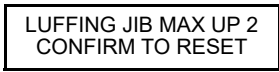

**FIGURE 3-13**

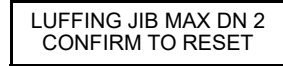

**FIGURE 3-14**



**WARNING**  
**Falling Boom/Jib Hazard!**

Proceed slowly when operating the luffing jib above the Max Up 1 limit.

Do not raise luffing jib above Max Up 2 limit. Structural damage will occur, possibly causing boom and luffing jib to be pulled over backwards.

**WARNING**  
**Falling Boom/Jib Hazard!**

Do not lower luffing jib below minimum angle given in Luffing Jib Raising Procedure in Capacity Chart Manual. Structural damage can result, possibly causing boom and luffing jib to collapse.

**Max Bail**

Automatically stops the corresponding drum from hoisting when there is a preset maximum number of wire rope layers on the drum.

The load can be lowered after the limit is contacted.

The appropriate limit bypass switch must be turned to the bypass position before a load can be hoisted above the limit.

**Luffing Jib Down Limits**

One or two luffing jib down limit stops are provided:

- **MAX DOWN** (past production minimum working angle): automatically stops the luffing hoist when the boom to luffing jib angle is 70°. This limit is controlled by a limit switch.
- **MAX DOWN 1** (current production minimum working angle): automatically stops the luffing hoist when the boom to luffing jib angle is 70°. This is a programmed limit controlled by angle sensors on the boom and jib.
- **MAX DOWN 2:** automatically stops the luffing hoist when the boom to luffing jib angle is 69° to 66°. This limit is controlled by a limit switch.

Refer to [Table 3-2](#) or [Table 3-3](#) to determine if this limit can be bypassed.

The luffing jib can be raised after the limit is contacted.

**NOTE:** For Crane Serial Number 18001082 and newer meeting 2010 European Requirements, the luffing jib cannot be raised after jib maximum down 2 limit is contacted until the limit switch is reset. When the limit is contacted, the screen shown in [Figure 3-14](#) will appear on the digital display.

Once the screen appears, confirm it to reset the limit switch. The luffing jib can then be raised.



**WARNING**  
**Falling Load Hazard!**

Do not exceed maximum allowable spooling capacity given in Wire Rope Specifications Chart in operator's cab. Wire rope could jump off drum allowing load to fall.

**Min Bail**

Automatically stops the corresponding drum from lowering when there are three wraps of wire rope remaining on the drum.

The load can be raised after the limit is contacted.

The appropriate limit bypass switch must be turned to the bypass position before a load can be lowered below the limit.



**WARNING**  
**Falling Load Hazard!**

When lowering load below minimum bail limit, do so slowly with extreme caution. Do not lower load to point where less than three full wraps of wire rope are on drum; wire rope could be pulled out of drum allowing load to fall.



**Load Moment** (Rated Capacity indicator/limiter)

See separate Rated Capacity Indicator/Limiter Operation Manual for operating instructions.

**! WARNING**  
**Overload Hazard!**

A Rated Capacity Indicator/Limiter has been installed on crane to aid operator.

Presence of RCL on crane in no way substitutes for or lessens requirement that operator knowledge, experience, and judgment are required to ensure safe operation of crane.

Before using RCL, operator shall:

- Read and thoroughly understand operating instructions.
- Make sure RCL is operating properly.
- Make sure RCL is calibrated properly.

**SEAT CONTROLS**

**! WARNING**  
**Moving Load Hazard!**

Operator, be aware that backrest is spring loaded. If you get out of seat to adjust backrest, it will spring forward.

To prevent backrest from springing forward into control handles and activating crane functions, park all crane functions before getting out of seat.

**CAUTION**

**Avoid Damage!**

Disconnect electric cord from rear of left console before you remove seat from operator's cab.

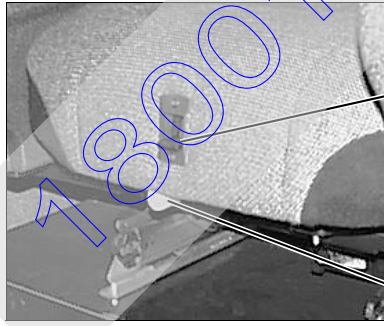

P1743

**BACKREST**

- Move switch up to release backrest.
- Use body weight to adjust backrest.
- Release switch to lock position of backrest.

**SEAT FORE-AFT**

- Push lever to left to unlock.
- Use body weight to slide seat to desired position.
- Release lever and make sure it is latched to lock seat in position.

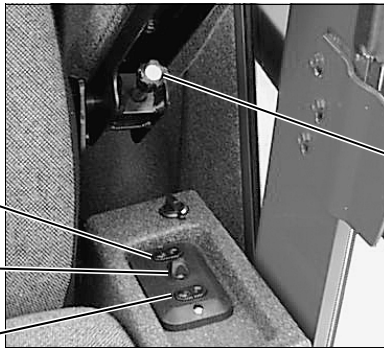

P1708a

**Left Side of Seat Under Armrest**

**ARMREST**

- Turn knob clockwise to raise armrest or counterclockwise to lower armrest.

**SEAT HEIGHT AND POSITION**

- Move rear switch up or down to raise or lower seat rear.
- Move center switch to raise/lower seat and move it forward/backward.
- Move front switch up or down to raise or lower seat front.

**FIGURE 3-15**

## PREPARING CRANE FOR OPERATION



### WARNING

#### Read Capacity Charts!

Do not attempt to operate crane without first reading and understanding capacity charts.

Crane must be rigged and operated according to instructions given in capacity charts and rigging guides.

Unless otherwise specified in capacity charts, all crane operations must be performed with crane level to within one 1% of grade in all directions —1 ft in 100 ft (0,3 m in 30 m); otherwise, crane could tip.

Do not operate crane, to include raising boom from ground level, if wind exceeds limits given in Capacity Charts. Contact your local weather station for wind velocity.

Failing to comply with capacity chart requirements can result in tipping or structural failure of boom/luffing jib.

#### Moving Load Hazard!

Operator shall select proper operating mode before operation.

Unexpected drum motion or improper limit responses can result if wrong mode is selected.

Limit bypass switch must be in ENABLE position and all available limits must be operational before operating crane.

Sound horn to alert personnel that operation is about to begin.

## CAUTION

### Machinery Damage!

Before operating crane at start of each shift, perform preventive maintenance checks and lubrication requirements listed in Sections 5 and 6 of this manual.

Adjust operator's seat as shown in [Figure 3-15](#).

### Jacking Cylinder Damage!

Rotating bed jacking cylinders can extend during operation.

Operator must check cylinders at start of each shift and midway through each shift. Check that jacking cylinders have not extended more than on inch (25 mm). See decal on cylinders for additional instructions.

Retract cylinders fully if they have extended.

## CALIBRATION PROCEDURES

To ensure proper operation of the crane functions, the hydraulic system must be properly calibrated. See Hydraulic System Calibration Procedures in this section for calibration requirements.



## OPERATION

### Engine Startup



#### **WARNING** Moving Machinery Hazard!

To avoid injuring personnel or damaging crane and property:

- Do not start engine if warning or out-of-order sign is present at start controls.
- Check that all controls are off so crane and load do not move when engine is started.

Check that all personnel are clear of crane before starting engine. *Sound horn to alert personnel.*

*Read and understand starting instructions in Engine Operation and Maintenance Manual provided with crane.*

If equipped, the dead-man switch must be held in to increase engine speed and to operate any crane function (travel, swing, boom hoist, all load drums).

1. If used, unplug or turn off engine block heater, hydraulic tank heaters and any other component heater the crane may have.

**NOTE:** Manitowoc recommends the use of engine block heaters and hydraulic tank heaters to aid start-up when the ambient temperature will be 32°F (0°C) and below.

2. Open hydraulic tank shut-off valves ([Figure 3-16](#)).
  - Current production — to open, pull lock pin out and rotate handle 90 degrees (handles in line with hose). Reverse procedure to close handles.
  - Past production — to open, unscrew handle and rotate 90 degrees (handles in line with hose) Reverse procedure to close handles.

#### **CAUTION**

##### **Pump Damage!**

Do not start engine until hydraulic tank shutoff valves are open; otherwise, pumps could cavitate and be damaged.

#### Hydraulic Tank Shut-Off Valves Accessible at Rear of Left Side Enclosure

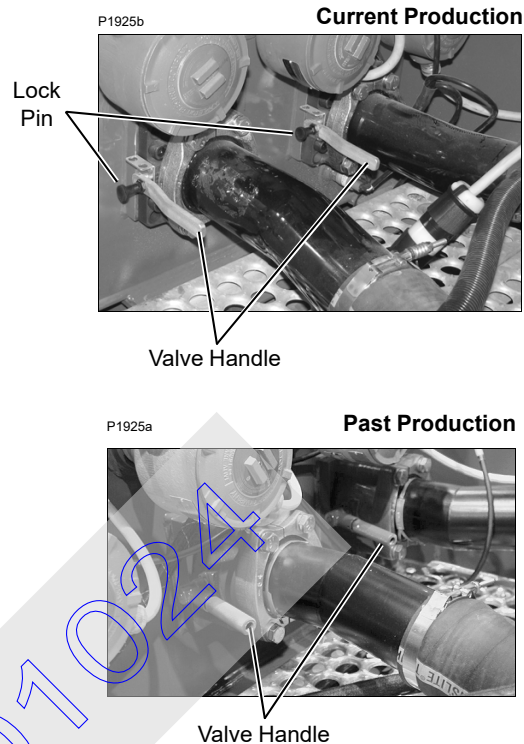

**FIGURE 3-16**

3. Turn ignition switch to RUN position.

**NOTE:** All indicator lights, operating limit buzzer, and system fault beeper should come on for two to three seconds when ignition switch is in RUN position; if not, replace defective parts.

4. If ambient temperature is below 40°F (4°C), disengage engine clutch, as shown in [Figure 3-17](#). This step will disconnect the pumps from the engine and aid in cold weather startup.

#### **CAUTION**

##### **Engine Clutch Damage!**

Observe the following precautions for engine clutch:

- **Decrease engine speed to 1300 RPM or less** before engaging or disengaging clutch.
- Do not run engine longer than twenty minutes with clutch disengaged.
- Disengage and engage clutch several times monthly with engine running.

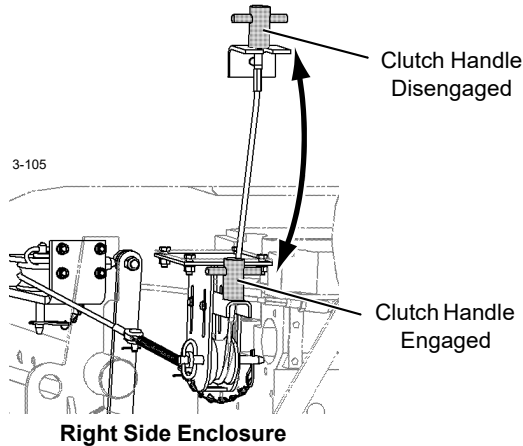

FIGURE 3-17

- Turn ignition switch to START.

The engine has an ether start system that automatically injects a preset volume of ether into engine, when the ambient temperature is below a preset degree.

**CAUTION**

**Starter Motor Damage!**

If engine does not start after cranking 30 seconds, wait 2 minutes so starter motors can cool before trying again.

- Increase engine speed as necessary to keep engine running after engine starts. Allow engine to run until it begins to warm up.



**WARNING**

**Engine Damage!**

Engine must have adequate oil pressure within 15 seconds after starting. If not, shut down engine immediately to avoid damage.

- If disengaged, set engine speed at 1,300 RPM and **engage engine clutch slowly** to give engine time to take on added hydraulic load.
- It is normal for engine speed to drop to as low as 400 RPM as clutch is engaged (due to increased load of pumps and pump drive):

- If engine stalls, disconnect clutch and wait 5 minutes. Re-start engine and run engine at low idle for no more than 20 minutes. Repeat Step 7.
- If engine remains running, engine speed should increase above 600 RPM within 5 seconds. If it doesn't, **stop engine or disengage clutch immediately to avoid pump drive damage**. Run engine at low idle for no more than 20 minutes. Repeat Step 7.

It is also normal for system fault alert and engine warning/diagnostic lights to come on after engine starts. Alert and lights should go off as engine oil pressure, hydraulic oil pressure, and hydraulic oil temperature rise to normal – if no other faults exist.

Once clutch is engaged (and engine remains running), decrease engine speed as low as possible (above 600 RPM) without stalling engine to **give system fault alert and engine warning/diagnostic lights time to turn off**.

- Run engine at low idle until hydraulic oil temperature is at least 60°F (16°C) and **all faults are off**.

**CAUTION**

**Machinery Damage!**

Do not run engine below 600 RPM for longer than 5 seconds with clutch engaged. Serious damage to pump drive will result.

Do not operate crane when system fault alert or engine warning/diagnostic lights are on. If faults don't turn off after startup or come on during operation, proceed as follows:

- Determine fault on digital display
- Land loads if possible. Otherwise, apply drum brakes and park all functions
- Move all control handles to off
- Stop engine
- Correct cause of fault

Continuous operation with hydraulic oil temperature above 180°F (82°C) can damage hydraulic components. Troubleshoot hydraulic system if oil temperature exceeds 180°F (82°C).

- Confirm current selected crane mode or select and confirm another crane mode. Load drums and boom hoist are inoperable until this step is performed (operating limit alert will come on and CONFIRM MODE will appear on digital display if operation is attempted).

**CAUTION**

**Mast Assist Damage!**

Prevent damage to live mast assist arms and cylinders during cold weather:

- Do not attempt to lower live mast with boom hoist until temperature of hydraulic oil is 60°F (16°C).
- Once oil is at above temperature, fully extend and retract live mast cylinders twice to fill with warm oil.

Cylinders and arms will bend under weight of live mast if this precaution is not taken.

See [Figure 3-18](#) for the following description of operation.

**CAUTION**

**Rigging Damage!**

Check that boom hoist wire rope is reeved through all sheaves and spooled properly onto boom hoist drum before raising boom from ground.

See Boom Rigging drawing in Section 4 for wire rope and reeving specifications. See Wire Rope Installation in Section 4 for instructions on attaching wire rope to boom hoist drum.

1. Select and confirm STANDARD mode.

**NOTE:** In Standard mode, the boom hoist drum is controlled by handle **A**. See handle display light to determine what drum is controlled by what handle.

2. Turn off boom hoist park (drum 4).

**CAUTION**

**Boom Damage!**

Do not turn on boom hoist park while raising or lowering boom; brake will bring boom to an abrupt stop. This action could cause shock load damage to boom. Bring boom to a smooth stop with boom hoist handle and then turn on boom hoist park.

3. Increase engine speed to desired RPM with hand throttle. Depress foot throttle to momentarily increase engine speed when more power is required.

4. Move boom hoist handle **A** (Drum 4) BACK from off to RAISE boom or move handle FORWARD from off to LOWER boom.

**NOTE:** When luffing mode is selected, the boom hoist drum is controlled by Handle **D**.



**WARNING**

**Two-Blocking Hazard!**

Pay out load lines while lowering boom. Load may contact boom point or jib point sheaves if this step is not taken. Wire rope or other parts could break allowing load to fall.

5. As boom nears desired angle, slowly move boom hoist handle **A** toward off to decrease speed. Then move handle **A** to off to stop boom and hold it in position (park brakes spring apply).

**NOTE:** Besides being equipped with a boom up limit, a physical boom stop cushions boom raising between approximately 75° and the Max Up limit.

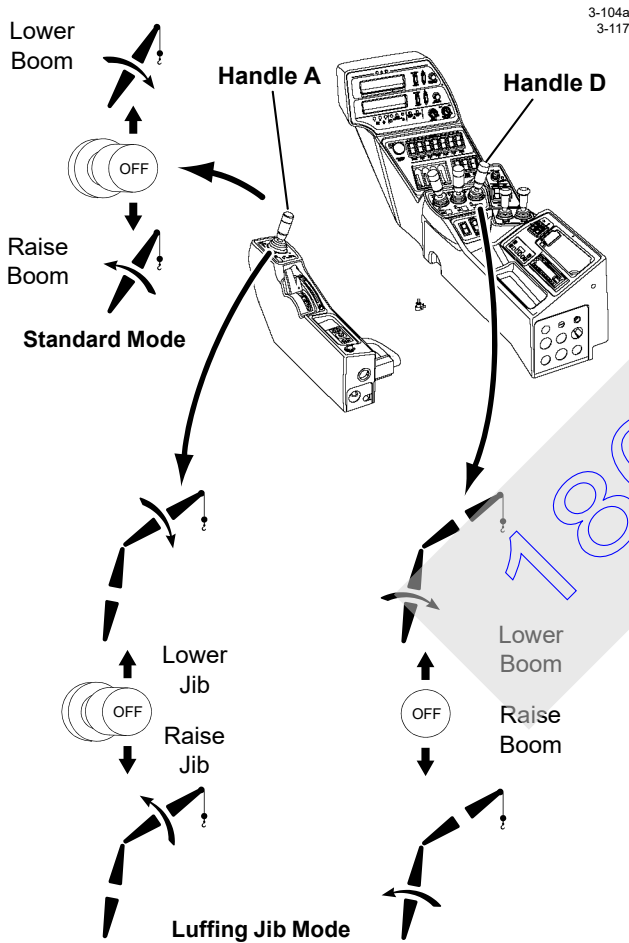

**FIGURE 3-18**

**NOTE:** The speed of each crane function (all drums, swing and travel) and swing torque can be adjusted to suit operator needs. See Function Speed/Torque Adjustment later in this section.

**Boom Hoist Operation**

See [Figure 3-10](#) for drum identification.

The boom stop also provides a physical stop at 85°.

6. Turn on drum 4 park if boom angle will not be changed.

**CAUTION**  
**Rigging Damage!**

When lowering boom to ground:

- If equipped, disconnect fixed jib stop before jib point contacts ground.
- If equipped, remove upper boom point before upper point contacts ground.

**Luffing Hoist Operation**

See [Figure 3-10](#) for drum identification.

See [Figure 3-18](#) for the following description of operation.

See [Figure 3-19](#) for identification of boom and luffing angles.



**WARNING**  
**Death or Serious Injury!**

Read and understand instructions in Luffing Jib Rigging Guide before attempting to raise or lower luffing jib from or to ground.

**CAUTION**  
**Rigging Damage!**

Check that luffing hoist wire rope is reeved through all sheaves and spooled properly onto Drum 6 before raising boom and jib from ground.

See Luffing Jib Rigging drawing for wire rope and reeving specifications. See Wire Rope Installation in this section for instructions on attaching wire rope to drum 6.

1. Select and confirm Luffing mode.

**NOTE:** When Luffing Jib mode is selected, the boom hoist drum is controlled by Handle **D**. See handle display

light to determine what drum is controlled by what handle.

2. Turn off Drum 6 park.

**CAUTION**  
**Boom or Luffing Jib Damage!**

Do not turn on drum 6 park while raising or lowering luffing jib. Brake will bring luffing jib to an abrupt stop. This action could cause shock load damage to boom and jib. Bring luffing jib to smooth stop with handle **A** and then turn on drum 6 park.

3. Increase engine speed to desired RPM with hand throttle. Depress foot throttle to momentarily increase engine speed when more power is required.
4. Push handle **A** (Drum 6) FORWARD from off to LOWER luffing jib or pull handle BACK from off to RAISE luffing jib.



**WARNING**  
**Two-Blocking Hazard!**

Pay out load lines while lowering luffing jib. Load may contact luffing jib point sheaves if this step is not taken. Wire rope or other parts could break allowing load to fall.

5. As luffing jib nears desired angle, slowly move handle **A** toward off to decrease speed. Then move handle **A** to off to stop luffing jib and hold it in position (park brake will apply).
6. Turn on Drum 6 park if luffing jib angle will not be changed.

**CAUTION**  
**Luffing Jib Damage!**

When lowering boom and luffing jib to ground, disengage luffing jib stop at specified boom to luffing jib angle (see Luffing Jib Rigging Guide).

A1258

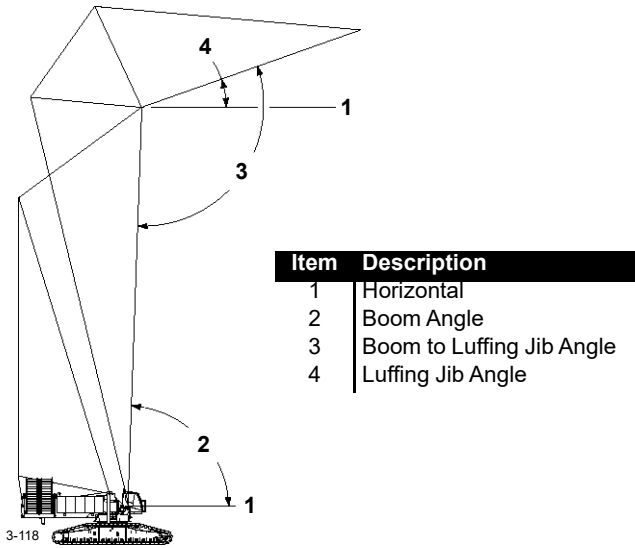

FIGURE 3-19

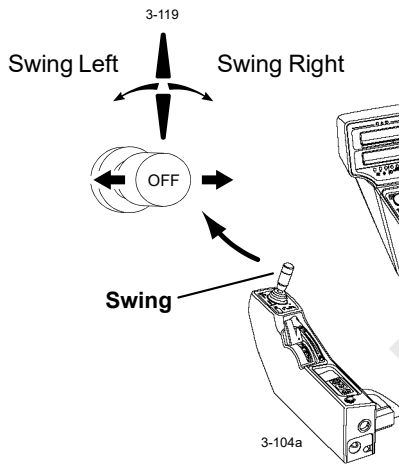

FIGURE 3-20

**Swing Operation**

**NOTE:** Swing lock is not available on current production.

See [Figure 3-20](#) for the following description of operation.

**! WARNING**  
**Tipping Hazard!**

Prevent crane from tipping. Adhere to any swing limitations given in capacity charts.

**! DANGER!**  
**Moving Crane Hazard!**

Counterweights can strike personnel in area of swing path! Warn personnel to stay clear of swing path. Sound horn prior to swinging.

1. Turn off swing park.

**CAUTION**  
**Boom/Swing Drive Damage!**

Do not apply swing holding brake or turn on swing park while swinging. Brake will bring upperworks to an abrupt stop. This action could cause damage to boom from side loading or damage to swing drive from shock loading. Bring upperworks to a smooth stop with swing handle and then apply swing holding brake or turn on swing park.

2. Increase engine speed to desired RPM with hand throttle. Press foot throttle to momentarily increase engine speed when more power is required.
3. Push swing handle to LEFT from off to SWING LEFT or pull swing handle to RIGHT from off to SWING RIGHT.
4. Start swing motion with a smooth acceleration. Continue handle motion to swing at desired speed.
  - Program the swing speed and torque to meet operator comfort. See Function Speed/Torque Adjustment in this section.
  - If equipped with optional swing limits, adjust switches to stop upperworks at desired position in either direction.
5. Stop swinging by releasing swing handle to off. Swing speed will decrease to off and upperworks will coast to a stop. If a faster stop is desired, move swing handle past off to opposite swing direction.
6. Once upperworks stops, apply swing holding brake to hold upperworks in position for short periods during operating cycle.

To hold upperworks in position for long periods, turn on swing park.

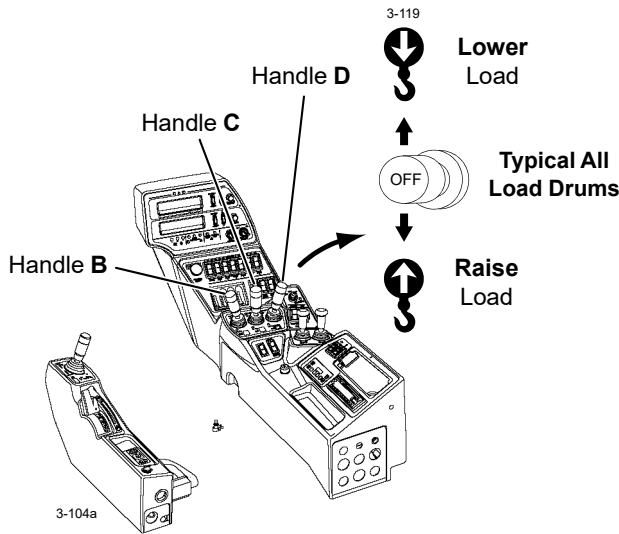

FIGURE 3-21

**Load Drum Operation**

See [Figure 3-10](#) for drum identification.

See [Figure 3-21](#) for the following description of operation.

**! WARNING**

**Falling Load Hazard!**

Prevent load on unused drums from falling. Turn on drum park for drums not in use.

1. Select and confirm desired crane mode.
2. Depending on mode selected, load drums are controlled by handles **B**, **C** or **D**. See handle display light to determine what load drum is controlled by what handle.
3. Turn off drum park for drum to be operated.

**CAUTION**

**Boom Damage!**

Do not turn on load drum park while raising or lowering load. Brake will bring load to an abrupt stop. This action could cause shock load damage to boom and load line. Bring load to a smooth stop with control handle and then turn on drum park.

4. Increase engine speed to desired RPM with hand throttle. Depress foot throttle to momentarily increase engine speed when more power is required.

**CAUTION**

**Drum Spooling Backlash!**

Lowering/hoisting with reduced rope tension (slack) will cause drum spooling backlash, improper spooling of wire rope on the drum, and possible pull through. The crane operator shall maintain proper rope tension while lowering/hoisting load blocks, booms, and luffing jibs.

5. Pull load control handle **B**, **C** or **D** (Drum 1, Drum 2, or Drum 3) **BACK** from off to **RAISE** load or push load control handle **FORWARD** from off to **LOWER** load.

**NOTE:** Excessive speed will cause drum spooling backlash with reduced rope tension as a result of:

- Boom and luffing jib at high angles
  - Wind loading from front
  - Light load blocks
6. As load nears desired position, slowly move load control handle toward off to slow down load. Then release handle to off to stop load and hold it in position (drum park brake will apply).



## Travel Operation



### WARNING

#### Tipping Hazard!

Travel surface must be firm and uniformly supporting.

For *traveling with load*, grade must not exceed 1% — 1 ft in 100 ft (0,3 m in 30 mm) — in any direction.

For *traveling without load*, grade in direction of travel must not exceed 30% — 30 ft in 100 ft (9 m in 30 m); grade from side to side must not exceed 2% — 2 ft in 100 ft (0,6 m in 30 m), measured at boom hinge pins.

For all travel on grades, see Maximum Allowable Travel Specifications chart in Capacity Chart Manual.

Failing to comply with above specifications can result in tipping.

#### Moving Crane Hazard!

Know position of upperworks with relation to lowerworks before traveling. An accident can result if crane travels opposite intended direction.

### CAUTION

#### Boom Damage!

To prevent shock loading boom and rigging:

- Perform all travel functions — starting, turning, stopping — slowly and smoothly.

#### Crawler Damage!

To prevent damage to crawler components (treads, rollers, frames), use care to prevent dirt from piling up at tumbler and roller ends of crawlers when turning on soft surfaces:

- Bring crawlers to a complete stop before changing travel direction
- Turn a few degrees. Then slowly travel forward or reverse so dirt falls away from crawlers. Continue this procedure until desired turn has been made.
- Avoid sharp turns ([Figure 3-23](#)) if possible
- Make gradual turns ([Figure 3-24](#)) or counter-rotate ([Figure 3-25](#)) whenever possible so both crawlers are always powered
- Clean crawlers often
- Keep crawler treads properly adjusted

1. Before traveling:
  - a. Plan travel route. It must be free of ground and overhead constructions.
  - b. Check crawlers for proper adjustment.
  - c. Warn personnel to stand clear of travel area. *Do not travel without a signal person.*
2. Position boom at or above boom angle given on capacity chart when *traveling with load*.
3. Travel with boom in-line with crawlers except when swinging is necessary while traveling. Travel with boom facing direction of travel.



### WARNING

#### Flying Object Hazard!

Excessive dirt build-up at tumbler and roller ends of crawlers can result in excessive tension in tread connectors. Tread connectors can break if over tensioned, causing treads to fly apart unexpectedly with dangerous force.

4. For *traveling with load*, carry load as close to ground as possible, stabilizing load with taglines.
 

For *traveling without load*, carry load block and weight ball low enough that they cannot swing into boom. If desired, tie off load block at front of rotating bed.
5. Increase engine speed to desired RPM with hand throttle. Depress foot throttle to momentarily increase engine speed when more power is required.
6. Select desired travel speed, low or high.

**NOTE:** The following directions of travel are with **front of upperworks and front of lowerworks facing same direction**.

- Operator's cab is at front of upperworks.
- Crawler motors are at rear of lowerworks.
- Crawler pin handles on carbody are at front of lowerworks.

**If front of upperworks and front of lowerworks face in opposite directions, crane will travel in the direction opposite handle movement.**

7. To TRAVEL STRAIGHT ([Figure 3-22](#)), move both crawler handles the same amount in desired direction from off.



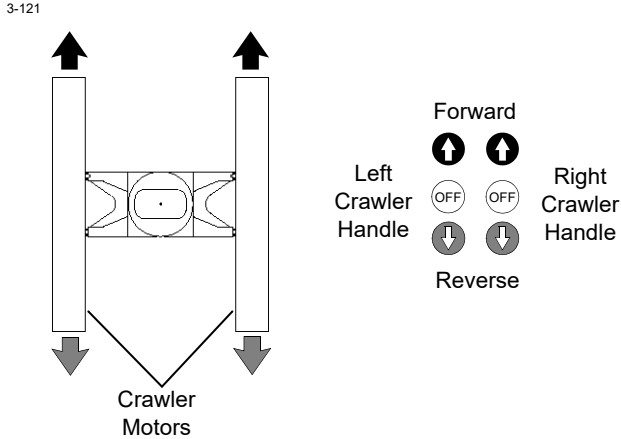

FIGURE 3-22

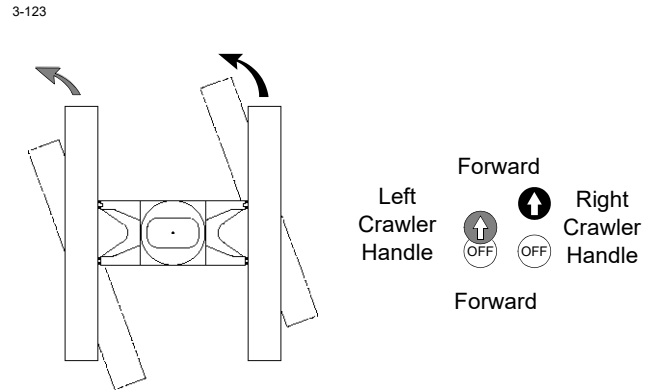

FIGURE 3-24

- 8. To make a SHARP LEFT TURN (Figure 3-23), move right crawler handle forward from off and leave left crawler handle in off. Crane will pivot about left crawler.
- 9. To make a SHARP RIGHT TURN, reverse step 8.

- 12. To COUNTER-ROTATE LEFT (Figure 3-25), move right crawler handle to front from off and move left crawler handle to rear from off.

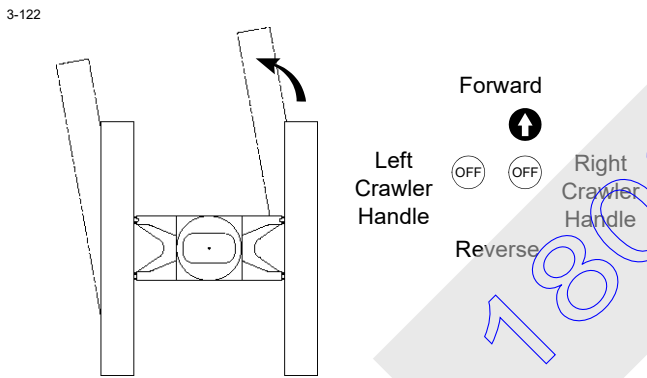

FIGURE 3-23

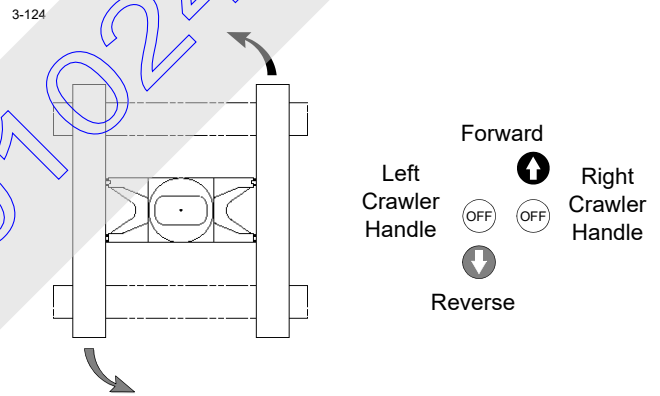

FIGURE 3-25

- 10. To make a GRADUAL LEFT TURN (Figure 3-24), move both crawler handles forward from off, but move right crawler handle farther forward than left crawler handle. Right crawler will turn faster than left crawler.
- 11. To make a GRADUAL RIGHT TURN, reverse step 10.

- 13. To COUNTER-ROTATE RIGHT, reverse step 12.
- 14. Slowly move both crawler handles to off to stop traveling and to hold crane in position.
- 15. Turn on travel park.

## STOPPING ENGINE/ LEAVING CRANE UNATTENDED



### WARNING

#### Moving Load/Tipping Crane Hazard!

Operator shall not leave operator's cab until crane, loads, and boom have been secured against movement.

Changing weather conditions including but not limited to: wind, ice or snow accumulation, precipitation, flooding, lightning, etc. should be considered when determining the location and configuration of a crane when it will be left unattended.

1. Travel crane onto a level surface. **Do not leave crane unattended on a grade.**
2. Turn on travel park.
3. Swing upperworks to desired position. Then turn on swing park.
4. Lower all loads to ground and fully apply drum working brakes.
5. Turn on drum park for each load drum.
6. If possible, lower boom and luffing jib onto blocking at ground level.

If the boom and luffing jib cannot be lowered, as determined by a qualified designated person, they must be securely fastened from movement by wind or other

outside forces (see Wind Conditions in Capacity Chart Manual).

**NOTE:** The designated person shall be familiar with the job site limitations, crane configuration, and expected weather conditions.

7. Check that all control handles are off.
8. Decrease engine speed to idle.  
Allow engine to idle for three to five minutes so it cools evenly.
9. Stop engine.
10. Remove all keys from cab to **prevent unauthorized operation.**
11. Lock operator's cab windows and door to **prevent unauthorized entry.**

P1976

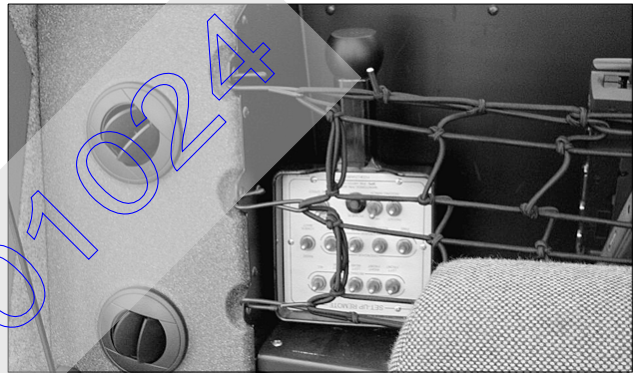

Shelf Behind Seat in Cab

FIGURE 3-26

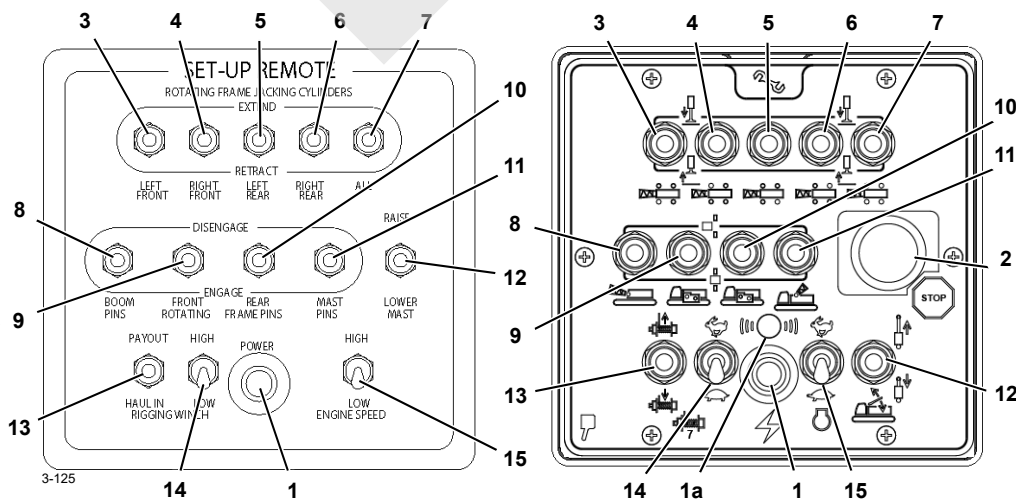

FIGURE 3-27

## REMOTE CONTROLS



### WARNING

#### Read Instructions!

To avoid death or serious injury to personnel and damage to crane:

- Read Crane Assembly and Disassembly instructions in Section 4 before operating remote controls.

### General

The following instructions identify and describe operation of the remote controls for crane setup. Disregard any control not equipped on your crane.

This crane has two remote controls:

- Wireless, electronic setup remote control shown in [Figure 3-27](#).
- Manually controlled crawler remote controls shown in [Figure 3-28](#).

## Controls Identification and Operation

### Setup Remote Control

The setup remote mode must be selected as follows before the controls on the setup remote controls can be operated:

- Using crane mode rocker on front console, press bottom of rocker (SELECT) until CRANE SETUP mode appears on digital display screen. Then press top of rocker to CONFIRM.
- Press bottom of rocker (SELECT) until SETUP REMOTE ON appears on digital display. Then press top of rocker to CONFIRM.

When this mode is on, \*R appears in the crane mode line of the digital display, as follows:

Crane Mode – STANDARD ON      \*R

- To turn off setup remote mode, press bottom of rocker (SELECT) until SETUP REMOTE OFF appears on digital display. Then press top of rocker to CONFIRM.

Both setup modes are turned off if operator selects a different operating mode.

Store the setup remote control in the operator's cab until needed (see [Figure 3-26](#)). **To prevent accidental operation of remote control switches, always select**

**SETUP REMOTE OFF mode when remote control is not in use.**

**NOTE:** A slight delay is normal from the time a remote toggle switch is enabled to the time the corresponding function operates.

Speed of operation depends on engine speed. To provide adequate speed, operate engine at mid to high idle.

On Crane Serial Number 18001082 and newer, the swing and travel alarm will sound continuously when a function is being operated with any of the setup remote controls.

Additionally on Crane Serial Number 18001082 and newer meeting European requirements, the controls in the operator's cab cannot be operated when the SETUP REMOTE mode is on.

### Power Controls

#### 1–Power Switch

DEPRESS button to TURN ON battery power to remote controls. If equipped, light (1a) will glow amber when power is on.

RELEASE button to TURN OFF battery power to remote controls.

#### 1a–Power Light

Available on Crane Serial Number 18001082 and newer, the light glows amber when power is on.

#### 2–Stop Switch

DEPRESS to STOP all setup functions in an emergency.

The knob must be pulled up before the setup functions can be operated.



### WARNING Moving Part Hazard!

To avoid serious crushing injury:

- Keep feet clear of moving jacks
- Warn all personnel to stay clear of jacks while they are being extended

#### Tipping Hazard!

To prevent rotating bed from tipping over:

- Do not allow rotating bed to get more than 3° out of level while jacking

### Jacking Controls

- 3–Left Front Jacking Switch
- 4–Right Front Jacking Switch
- 5–Left Rear Jacking Switch
- 6–Right Rear Jacking Switch

Move selected toggle UP and hold to EXTEND jacking cylinder.

Release toggle to CENTER to STOP jacking cylinder.

Move selected toggle DOWN and hold to RETRACT jacking cylinder.

### CAUTION

#### Machinery Damage!

To avoid damage to jacking cylinders, fully retract them before traveling.

### 7– All Jacking Switch

Move toggle UP and hold to EXTEND all jacking cylinders at same time.

Release toggle to CENTER to STOP jacking cylinders.

Move toggle DOWN and hold to RETRACT all jacking cylinders at same time.

**NOTE** When the ALL jacking switch is used, the crane's programmable controller will attempt to adjust the jacking cylinders to maintain or return the rotating bed to level as sensed by the rotating bed level sender.

Prior to using the ALL jacking switch, verify the accuracy of the rotating bed level sender with an user furnished digital level. The TILT RIGHT and TILT FRONT angles shown on the digital display should be the same as the angles shown on the digital level.

The CRANE LEVEL operating limit will appear on the digital display and the swing and travel alarm will sound if the rotating bed gets 3° out of level while jacking.

- Operation does not stop automatically when this alarm comes on.
- When this alarm comes on, **operator shall stop jacking and level rotating bed using individual jacking switches.**

If the rotating bed level sender indicates that the rotating bed is more than 4.7° out of level, the CRANE LEVEL SENSOR system fault will appear on the digital display, the swing and travel alarm will sound, and the ALL jacks switch will be disabled.

The rotating bed should then be leveled using the individual jacking switches, and the accuracy of the rotating bed level sender should be checked.

### Boom Pins Control



### WARNING

#### Falling Load Hazard!

To prevent boom or boom butt from falling off crane:

- Do not disengage boom hinge pins until boom butt is properly supported on stands at ground level. Boom/boom butt could fall off crane.

Read Boom Rigging Guide in Section 4 of this Manual.

### 8–Boom Pins Switch

Move toggle UP and hold to ENGAGE boom hinge pins.

Release toggle to CENTER to STOP pins.

Move toggle DOWN and hold to DISENGAGE boom hinge pins.

### Rotating Frame Controls

#### 9–Front Rotating Frame Pins Switch

#### 10–Rear Rotating Frame Pins Switch

Move selected toggle UP and hold to ENGAGE rotating bed pins.

Release toggle to CENTER to STOP.

Move selected toggle DOWN and hold to DISENGAGE rotating bed pins.

### Mast Controls

#### 11–Mast Pins Switch (Fixed Mast)

Move toggle UP and hold to ENGAGE fixed mast pins.

Release toggle to CENTER to STOP.

Move toggle DOWN and hold to DISENGAGE main mast pins.

#### 12–Mast Switch (Live Mast Arms)

Move toggle UP and hold to RAISE live mast arms with mast cylinders.

Release toggle to CENTER to STOP mast cylinders. Valves on the cylinders lock them in position.

Move toggle DOWN and hold to LOWER live mast arms with mast cylinders.

Read Crane Assembly and Disassembly in Section 4 for live mast raising and lowering instructions.

## Rigging Winch Controls

### 13–Rigging Winch Payout/Haul In Switch

Move toggle UP to PAYOUT and hold to payout wire rope from winch.

Release toggle to CENTER to STOP winch motor.

Move toggle DOWN to HAUL IN and hold to haul in wire rope to the winch.

### 14–Rigging Winch High/Low In Switch

Move toggle UP to HIGH to operate winch in high speed.

Move toggle DOWN to LOW to operate winch in low speed.

## Engine Speed Control

### 15–Engine Speed Switch

The engine speed switch allows the operator to select high or low engine idle speed from a remote position. Speed of operation (jacks and pins) depends on toggle switch movement and engine speed. To provide adequate speed for some setup items, engine should be operated at high idle.

Place toggle UP to HIGH to operate engine at high idle.

Place toggle DOWN to LOW to operate engine at low idle.

## Crawler Pin Controls

See [Figure 3-28](#) for the following procedure.

The manually operated crawler pin handles are located on front of carbody. The crane must be in the setup mode and the engine running before the crawler pin handles are operable. Crawler pins cannot be disengaged until locking pins are removed. Read Crane Assembly and Disassembly Guide in Section 4 for crawler pin handle setup instructions.

### 16–Right Crawler Pin Handle

### 17–Left Crawler Pin Handle

Pull selected crawler pin handle DOWN to ENGAGE crawler pins.

Release handle to CENTER to when pins are fully engaged.

Push selected crawler pin handle UP to DISENGAGE crawler pins.

P1927b

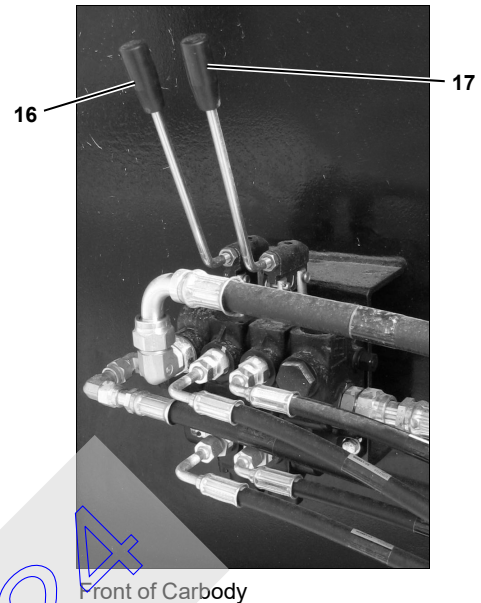

FIGURE 3-28

## Replacing Batteries in Setup Remote Control

When battery voltage in the setup remote control is low, BATTERY VOLTAGE LOW is displayed on the wireless screen in the digital display (see Crane Diagnostics in this section). Replace the batteries at that time as follows:

- Remove end cap at bottom of handle.
- Slide two existing batteries out of handle. Gasket must remain intact.
- Replace with two AA lithium Eveready Energizer L91 batteries. AA alkaline batteries can be used, but they will have a shorter battery life, especially in cold weather.
- Reinstall end cap.

### DIGITAL DISPLAY SCREENS

The digital display and scroll up/down rocker (see Special Controls in this section) allow the operator to monitor operating conditions screen, operating limits screen, or system faults screen.

To display one of the above screens, depress the top or bottom of the digital display selector (D5, [page 3-22](#)) to scroll up or down through the display readings. Continue to scroll up or down until desired screen is displayed.

### Crane Operating Conditions

[Table 3-4](#) lists operating conditions that are displayed and the normal operating range of each item. The current status of operating conditions are displayed in the screen shown in [Figure 3-29](#).

ENGINE SPEED	2,200 RPM
BOOM ANGLE	66.0 DEG
LUFFING JIB ANGLE	00.0 DEG
BOOM TO LUFF ANGLE	000.0 DEG

FIGURE 3-29

The engine screen ([Figure 3-30](#)) displays the following information.

FUEL LEVEL	100%
OIL PRESSURE	50 PSI
COOLANT TEMP	150 DEG
ENGINE HOURS	1800

FIGURE 3-30

The engine diagnostics screen ([Figure 3-31](#)) displays engine faults. See Engine Diagnostics in this section for information on fault codes.

ENGINE DIAGNOSTICS		
FLASH CODE -	SPN-	FMI-

FIGURE 3-31

The mast angle, battery voltage, and crane level screen ([Figure 3-32](#)) displays the following information.

MAST ANGLE	DEG 000
BATTERY VOLTAGE	V
TILT RIGHT	DEG 000
TILT FRONT	DEG 000

FIGURE 3-32

On crane Serial Numbers 18001081 and older, the wind speed and pump drive screen ([Figure 3-33](#)) displays the current steady wind speed, maximum gust wind speed, and pump drive operating conditions.

- MAX WIND SPEED resets when crane power is off.

Pump drive operating conditions are provided only on current production cranes (pump drives with a circulating oil system).

CURRENT WIND SPEED	10 MPH
MAX WIND SPEED	20 MPH
PUMP DRIVE TEMP	160 DEG
PUMP DRIVE PRESSURE	25 PSI

FIGURE 3-33

On crane Serial Number 18001082 and newer, the hydraulic tank fluid level, wind speed, and pump drive screen ([Figure 3-34](#)) displays the hydraulic tank fluid level, the current steady wind speed or maximum gust wind speed (in parenthesis) and pump drive operating conditions.

- For hydraulic tank level: 0% = empty; 100% = full cold; 110% is full hot.
- MAX WIND SPEED resets when crane power is off.

HYD TANK FLUID LEVEL	100 %
CURRENT (MAX) WIND SPEED	20 MPH
PUMP DRIVE TEMP	160 DEG
PUMP DRIVE PRESSURE	25 PSI

FIGURE 3-34



### Operating Limits

[Table 3-5](#) lists operating limits which can be displayed.

When one or more operating limit is reached, the operating limit alert (yellow light and buzzer in cab) turns on to warn the operator. Scroll to the crane faults/limits display screen. The crane faults/limits screen ([Figure 3-35](#)) automatically scrolls through the active faults/limits, stopping at each for approximately three seconds.

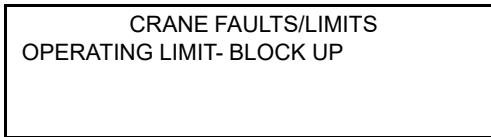

FIGURE 3-35

The operating limit alert turns off when the cause of limit is corrected. Each active limit reached during operation is retained in memory, until two things happen:

1. Name of limit appears on display at least once.
2. Cause of limit is corrected.

For this reason, it is normal for the inactive limits to appear when you scroll to the operating limit group, even when the operating limit alert is off.

To erase the inactive limits, scroll to the operating limit group. Wait until the display scrolls through the name of each limit. Inactive limits will be erased automatically. If the alert is on, only the names of active limits will remain.

NO FAULT appears on the display ([Figure 3-36](#)) when no limits have been reached.

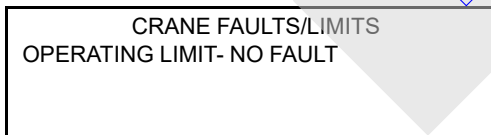

FIGURE 3-36

### System Faults

[Table 3-6](#) lists system faults which can be displayed.

When one or more system fault occurs, the system fault alert (red light and beeper in cab) turns on to warn the operator. Scroll to the crane faults/limits display screen. The screen ([Figure 3-37](#)) automatically scrolls through the active faults/limit, stopping at each for approximately three seconds.

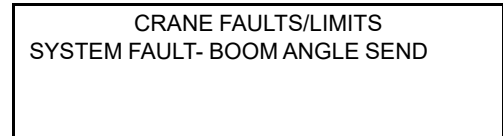

FIGURE 3-37

The system fault alert turns off when the cause of each fault is corrected. Each active fault that has occurred during operation is retained in memory, until two things happen:

1. Name of fault appears on display at least once.
2. Cause of fault is corrected.

For this reason, it is normal for the names of inactive faults to appear when you scroll to the system fault group, even when the system fault alert is off.

To erase the names of inactive faults, scroll to the system fault group. Wait until the display scrolls through the name of each fault. Inactive faults will be erased automatically. If the alert is on, only the names of active faults will remain.

NO FAULT appears on the display ([Figure 3-38](#)) when there are no faults.

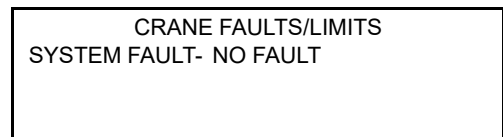

FIGURE 3-38





**Table 3-4 Operating Conditions**

Listed below are the operating conditions which can be viewed on the digital display.

Display Reading	Unit of Measure	Operating Range
<b>Normal Operating Conditions</b>		
The operating conditions listed below are displayed by scrolling up or down with the digital display selector.		
ENGINE SPEED	RPM	1,050 RPM low idle; 1,800 RPM high idle.
BOOM ANGLE	DEG	Degrees boom is positioned above horizontal.
LUFFING JIB ANGLE [1]	DEG	Degrees luffing jib is positioned above horizontal.
BOOM TO LUFF ANGLE [1]	DEG	Degrees between centerline of boom and centerline of luffing jib.
FUEL LEVEL	%	Indicates 0-100% of fuel remaining in tank.
OIL PRESSURE	PSI	Indicates engine oil pressure when operating.
COOLANT TEMP	DEG F	Indicates temperature of coolant in engine.
ENGINE HOURS	HOURS	Indicates total number of hours the engine has been run.
ENGINE DIAGNOSTICS	—	Indicates engine fault codes and engine troubleshooting.
MAST ANGLE	DEG	Degrees live mast is positioned above transport position, which is 0°
BATTERY VOLTAGE	V	Indicates crane battery voltage.
TILT RIGHT (Crane Level) TILT FRONT (Crane Level)	DEG/IN	Angle (+ or - degrees) that crane is out of level in indicated direction from horizontal.
HYD TANK FLUID LEVEL	%	Indicates hydraulic tank fluid level in % full.
CURRENT WIND SPEED	MPH	Indicates current steady wind speed.
(MAX) WIND SPEED	MPH	Indicates maximum gust wind speed.
PUMP DRIVE TEMP	DEG F	Indicates temperature of oil in pump drive.
PUMP DRIVE PRESSURE	PSI	Indicates pump drive oil pressure when operating.
<b>Diagnostic Screens</b>		
Operating conditions listed below are displayed only by turning limit bypass switch and scrolling up with digital display selector. To turn off diagnostic screens, turn limit bypass switch and scroll down or stop and restart engine.		
DRUM [2]	4 Rows of Text and Numbers in Display Screen	Text and numbers are used to monitor and troubleshoot controls and hydraulic systems. See Crane Diagnostics in this section for explanation of these screens.
SWING		
TRK (Travel)		
FCN (Front Console Node)		
CAN (CAN-Bus)		
ACC (Accessory System)		
WIRELESS		
LEVEL		
SPEEDS AND TORQUE		
HYD SYSTEM CHECK		
CRANE MODE (name of mode)	—	See Crane Mode Selector instructions in this section for procedure to select and confirm desired crane mode.
PROGRAM M000001.0JP	—	Computer Program Version. <i>Factory service personnel will request these numbers when troubleshooting crane problems.</i>
CON 00000000000	—	Computer and Crane Configuration Code. <i>Factory service personnel will request these numbers when troubleshooting crane problems.</i>

[1] Optional Item

[2] Appropriate Drum Number (see [Figure 3-10](#))

**Table 3-5 Operating Limits**

Listed below are limits which turn on the operating limit alert (yellow light and continuous buzzer). When the alert comes on, the OPERATING LIMIT group of the digital display indicates which limit has been reached. Take corrective action.

Display Reading	Function Response	Corrective Action
BLOCK LEVEL	Block level sensing fault.	Block angle exceeded for parts of line. See Block Level screen in Crane Diagnostic section.
BLOCK UP	Stops load drums from hoisting and boom/luffing jib from lowering.	Lower corresponding load or raise boom or jib.
CONFIRM MODE	All drums inoperable until an operating mode is selected and confirmed.	Select and confirm the desired operating mode (see Operating Controls in this section for procedure).
CRANE LEVEL SENSOR	Crane is 4.7° out of level while jacking or sensor is faulty.	Level crane with individual jacking switches or replace sensor if faulty.
FUNCTION PARKED	Function inoperable because it is parked.	Turn corresponding park switch off and sit down in operator's seat.
JIB BELOW HORIZONTAL <sup>[1]</sup>	Luffing jib operable. See capacity chart for luffing jib minimum operating angles.	Raise luffing jib above horizontal.
LOAD MOMENT	Stops all load drums from hoisting and boom/luffing jib from lowering.	Land load on load drum or raise boom or jib.
MAST BELOW 2 DEGREES	Stops down movement of live mast when lowering mast to transport position.	Pin live mast in place before retracting mast arm cylinders fully.
MAST TOO FAR FORWARD	Boom hoist (live mast) inoperable in lowering direction (occurs if mast is below 160°).	Raise live mast. Further lowering is not intended— <b>mast will fall.</b>
MAX DOWN	Stops boom from lowering (limit set at 0°). Stops past production luffing jib from lowering when boom to luffing jib angle is 70°.	Raise boom or luffing jib.
MAX DOWN 1	Stops boom from lowering (limit set at 0°). Stops current production luffing jib from lowering when boom to luffing jib angle is 70°. Jib can be lowered to max down 2 limit.	Raise boom or luffing jib.
MAX DOWN 2	Stops current production luffing jib from lowering when boom to luffing jib angle is 69° to 66°.	Raise luffing jib.
MAX UP 1	Stops boom from rising when maximum up limit is reached. <sup>[2]</sup> Stops luffing jib from rising when boom to jib MAXIMUM WORKING angle is reached. This angle can be bypassed to raise jib to Max Up 2 angle.	Lower boom/luffing jib (Angle varies. See Limit devices – Boom Up Limit in this section specifications).
MAX UP 2 <sup>[1]</sup>	Stops luffing jib from rising when boom to jib MAXIMUM angle is reached. This limit can be bypassed only when boom is below 50°.	Lower luffing jib.
MAX BAIL	Drum stops hoisting.	Operate drum in lowering direction.
MIN BAIL	Drum stops lowering.	Operate drum in hoisting direction.

Display Reading	Function Response	Corrective Action
SWING PARKED (cranes with swing lock)	Stops travel function with MAX-ER.	Place swing park in off position to travel.
SWING PARKED (cranes without swing lock )	Stops travel function without MAX-ER.	1) Place swing park in off position to travel. 2) Install W48 Shorting Plug in MAX-ER Junction Box <b>IF</b> configured without MAX-ER attachment. 3) Confirm swing brake release pressure on Swing (Crane) diagnostic screen; if below 200 psi, troubleshoot swing brake hydraulic circuit.

[1] Optional item

[2] Angle at which boom stops varies with attachment. See Max Up 1 (boom) table in this section for specifications.



**Table 3-6 System Faults**

Listed below are faults which turn on the system fault alert (red light and beeper). When the alert comes on, the SYSTEM FAULT group of the digital display indicates which fault has occurred. Take corrective action. The beeper sounds intermittently.

Display Reading	Function Response	Cause of Fault
BATTERY VOLTAGE LOW	Correct cause for low voltage to prevent faulty crane operation.	Battery voltage below 18 volts.
BOOM ANGLE SENDER	All functions operable, BOOM ANGLE and BOOM TO LUFF JIB ANG display will be faulty. Correct cause of angle sender fault as soon as possible.	Sender output voltage 0 volts or above 9.7 volts. Fault not active when crane is in SETUP mode.
CRANE LEVEL SENSOR	Jacking ALL switch inoperable. Crane is 4.7 degrees out of level	Use individual jacking switches to level crane.
DISABLED DIG OUTPUT	Affected system not operating properly. Correct cause of fault as soon as possible.	Electric signal interrupted between computer node and output device (for example: faulty brake solenoid or broken wire).
ENGINE OIL PRESSURE LOW	Does not affect operation. Correct cause of low oil pressure as soon as possible to prevent engine damage.	Oil pressure below 15 psi (1.0 bar).
ENGINE TEMP HIGH	Does not affect operation. Correct cause of overheating as soon as possible to prevent engine damage.	Engine coolant temperature above 205°F (96°C).
FILTER FAULT 1 or 2 <sup>[3]</sup>	All functions operable. Replace charge filter 1 or 2 as soon as possible. Cranes prior to S/N 18001082	Filter is dirty.
FILTER FAULT 4 <sup>[3]</sup>	All functions operable. Replace return filters as soon as possible. Cranes prior to S/N 18001082	Filter is dirty.
FILTER FAULT 1 <sup>[3]</sup>	All functions operable. Replace return filter 2 as soon as possible. Crane S/N 18001082 and newer. See <a href="#">Table 3-7</a> .	Filter is dirty.
FILTER FAULT 2 <sup>[3]</sup>	All functions operable. Replace return filter 3 as soon as possible. Crane S/N 18001082 and newer. See <a href="#">Table 3-7</a> .	Filter is dirty.
FILTER FAULT 4 <sup>[3]</sup>	All functions operable. Replace return filter 1 as soon as possible. Crane S/N 18001082 and newer. See <a href="#">Table 3-7</a> .	Filter is dirty.
FILTER FAULT 8 <sup>[3]</sup>	Oil flow through suction filter inside hydraulic tank blocked.	Remove blockage, or hydraulic pumps will be damaged from cavitation.
FUEL LEVEL SENDER	Five percent fuel remaining in tank. Does not affect operation.	Fill tank as soon as possible to prevent engine stoppage.
HYDRAULIC FAN	Tier 4 engine. Does not affect operation. Correct cause of fault as soon as possible to prevent engine or hydraulic system from overheating.	Fan system pressure below 500 psi (34 bar).
HYDRAULIC FLUID LEVEL LOW	Does not affect operation. Fill tank as soon as possible.	Hydraulic oil at CAUTION LOW LEVEL indicated on tank gauge.
HYDRAULIC FLUID TEMP LOW	Reduce loads and/or speeds to allow oil to warm.	Oil temperature in hydraulic tank is below 40°F (4°C).
HYDRAULIC FLUID TEMP HIGH	Does not affect operation. Reduce loads and/or speeds to allow oil to cool.	Oil temperature in hydraulic tank above 180°F (82°C).

Display Reading	Function Response	Cause of Fault
LOAD PIN	Load drum operation will stop.	Load pin voltage not within 0.5 - 9 volts.
LUFFING JIB ANGLE SENDER <sup>[1]</sup>	All functions operable, but JIB ANGLE and BOOM TO LUFF JIB ANG display will be faulty. Correct cause of angle sender fault as soon as possible.	Sender output voltage 0 volts or above 9.7 volts. Fault not active when crane is in SETUP mode.
MAST SYSTEM	Mast operation with boom hoist will stop.	Boom or accessory transducer voltage less than 0.6 volts.
PUMP DRIVE PRESSURE LOW <sup>[2]</sup>	Does not affect operation. Shut down and correct cause as soon as possible to prevent gear or bearing damage.	Gear oil pressure below 5 psi (0.34 bar). Check pump for proper operation. Check pump drive oil level.
PUMP DRIVE TEMP HIGH <sup>[2]</sup>	Does not affect operation. Shut down and correct cause as soon as possible to prevent gear or bearing damage.	Gear oil temperature above 250°F (121°C). Check oil cooler for proper operation. Check pump drive oil level.
SUPERCHARGE PRESSURE (Prior to S/N 18001082)	Does not affect operation. Shut down and correct cause as soon as possible to prevent pump cavitation.	Supercharge pressure at pressure switch (suction manifold) is less than 15 psi (1 bar). Check hydraulic supercharge system.
WIRELESS SYSTEM	Wireless load link sensing fault.	See wireless link information in separate Rated Capacity Indicator/Limiter manual.
EXTERNAL VAC	Does not affect operation. Disconnect external power supply cable.	External power supply cable connected to crane when attempting to swing.
HYDRAULIC FAN <sup>[4]</sup>	Does not affect operation. Fan will default to high speed. Correct cause of fault as soon as possible.	Fan control wiring or fan hydraulic circuit faulty.

[1] Optional item

[2] Pump drive faults apply only to current production cranes (pump drives with a circulating oil system).

[3] See lubrication F2104 for filter identification.

[4] Tier 4 only

**Table 3-7**  
Filter Replacement Cross-Reference (S/N 18001082 and newer)

FILTER FAULT INDICATION	Replace FILTER 1	Replace FILTER 2	Replace FILTER 3
FILTER 1		X	
FILTER 2			X
FILTER 3		X	X
FILTER 4	X		
FILTER 5	X	X	
FILTER 6	X		X

## FUNCTION SPEED/TORQUE ADJUSTMENT

The speed of each crane function (all drums, travel, swing) and swing torque can be adjusted to suit operator needs.

### Adjustment

To adjust the desired function's speed or swing torque, proceed as follows:

1. Stop operating the desired function and park it.
2. Access diagnostic screens (Figure 3-39):
  - a. Turn limit bypass key clockwise and scroll up at least one screen (D5, page 3-22).
  - b. Once step 2a is performed, release key and scroll up or down through diagnostic screens until speed and torque screen appears.
3. Press BOTTOM of CONFIRM/SELECT switch until cursor ( \* ) appears next to desired function.
4. Scroll up or down to change speed or torque of selected function to desired percentage between 25% and 100%.
5. Repeat steps 1, 3 and 4 for other functions, as desired.
6. Press BOTTOM of CONFIRM/SELECT switch until cursor ( \* ) disappears.
7. Adjustment is complete. The selected speeds and torque will remain in computer memory, even after engine is stopped.
8. If desired, turn off diagnostic screens:
  - a. Turn limit bypass key clockwise.
  - b. Once step 8a is performed, scroll down at least one screen and release key.

Stopping engine will also turn off diagnostic screens.

Cursor	Available Speed or Torque (25% to 100%)			
*	DRUM 1 SPEED	100 %	DRUM 6 SPEED	75 %
	DRUM 2 SPEED	100 %	TRAVEL SPEED	100 %
	DRUM 3 SPEED	100 %	SWING SPEED	75 %
	DRUM 4 SPEED	100 %	SWING TORQUE	50 %
	Functions			

FIGURE 3-39

## ENGINE DIAGNOSTICS

### General

The Cummins QSX15 Engine has two types of fault codes:

- Engine electronic fuel system fault codes
- Engine protection system fault codes

All fault codes are either active or inactive. Active engine faults can be viewed on the crane's digital display either with the engine running or with the engine off (run/stop/run switch in RUN position). Inactive faults can only be read with electronic service tool supplied by the engine manufacturer.

The engine diagnostic lights are mounted on the front console in the operator's cab as shown in Figure 3-40.

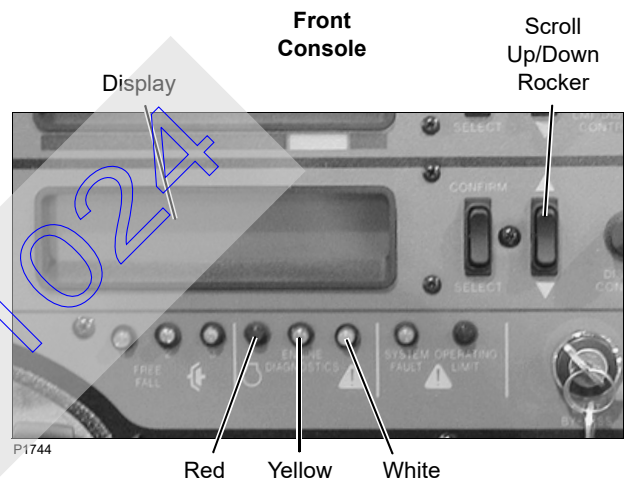

FIGURE 3-40

### RED STOP LIGHT

When on, the red stop light indicates the need to **stop engine as soon as safely possible** and correct the fault.

### CAUTION

If possible, lower lifted loads to ground and then stop engine as soon as possible when Red stop light comes on. Permanent damage can occur if engine is run while Red stop light is on. Do not run engine until fault is corrected.

### YELLOW WARNING LIGHT

When on, the yellow warning light indicates that engine can be run, but the fault should be corrected as soon as possible.

### WHITE MAINTAIN LIGHT

When on, the white maintain light indicates that engine maintenance is required. See engine manufacturer's manual for maintenance instructions.

### Onboard Engine Diagnostics

Active engine faults can be viewed on the crane's digital display either with the engine running or with the engine off (run/stop/run switch in RUN position). A list of fault codes is located in the operator's cab.

- Scroll up or down with rocker on right side of digital display screen until Engine Diagnostics screen appears.
- Corresponding flash code for each active fault will appear next to FLASH CODE as shown in [Figure 3-41](#).

The screen will automatically scroll through each fault at two-second intervals if more than one fault exists.

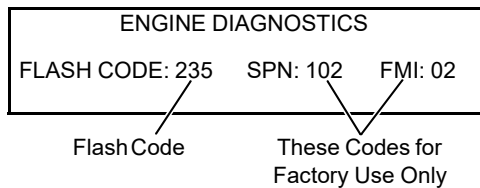

FIGURE 3-41

#### DPF Diagnostics — Cummins QSX 15 (Tier 4)

See [Figure 3-42](#) for the following procedure.

#### DPF High Temperature

GLOWS YELLOW to alert crane operator that the exhaust system temperature is higher than normal due to DPF regeneration.

### WARNING

#### High Exhaust Temperatures!

Active DPF Regeneration can occur at low engine idle as well as during crane operation. This may result in high exhaust temperature. Always keep personnel well away from the exhaust to prevent injury and possible death.

#### DPF Condition (Tier 4)

Displays one of three conditions if the Regeneration Inhibit switch is on (reference the Engine Manufacturer's Manual for additional information):

- GLOWS YELLOW when DPF is active and starting to fill. **Turn off regeneration inhibit switch.** No immediate action is required.
- FLASHING when DPF is nearly full. The operator may sense a reduction in power. **Turn off regeneration inhibit switch.** Perform a manual stationary regeneration of the DPF at earliest convenience.

- OFF when DPF is full and Red Engine Stop Light is ON. The soot level is critically high and past the point of a manual stationary regeneration. The operator will notice a significant reduction in engine power. **Turn off regeneration inhibit switch and shut down crane.** Do **NOT** perform a manual stationary regeneration. The DPF must be removed from the crane and physically cleaned, and the Red Engine Warning Light can only be cleared by a Cummins Service Technician (see Engine Manufacturer's Manual for details).

#### DPF Regeneration Inhibit (Tier 4)

GLOWS YELLOW when active regeneration has been stopped by pressing the Inhibit function (bottom) of the regeneration switch (A8). Excessive use of regeneration inhibit will result in the need to service or replace the DPF.

#### DPF Regen/Inhibit Switch

See A – Engine Controls for operation procedure.

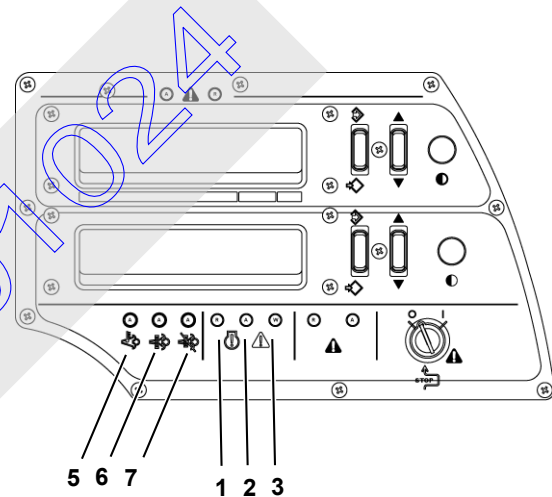

#### Tier 4 DPF Diagnostics

Item	Description
1	Engine Stop Light — Red
2	Engine Warning Light — Amber
3	Engine Maintenance Light — White
4	DPF Regen/Inhibit Switch (not shown)
5	DPF High Temperature — Amber
6	DPF Regen On — Amber
7	DPF Inhibit On — Amber

FIGURE 3-42



## CRANE DIAGNOSTICS

### General

To enable the diagnostic screens, turn limit bypass key switch clockwise and scroll up at least one screen (D5, [page 3-22](#)). Once this step is performed, you can scroll up or down through the diagnostic screens in addition to the operating screens. To disable the diagnostic screens, turn limit bypass key switch clockwise and scroll down. The operating screens remain active.

The diagnostic screens provide information about the status of all main crane components as well as the controller inputs and outputs during operation. The diagnostic screens display the following information:

- Particular crane functions — DRUMS, SWING, and TRACK. See [Figure 3-10](#) for drum location and identification.
- FCN (Front Console Node) and CAN (CAN Bus) screens display digital input and digital output information — [Table 3-11](#) (digital inputs to master node controller), and [Table 3-12](#) (digital outputs from crane master node controller). See [Figure 3-43](#) for location of node controllers.
- Controller programming information — These screens are for factory use only, and are not shown here.
- Hydraulic system calibration information — Check includes pressure sender calibration, control calibration, pump pressure test, and charge pressure test.
- Speed adjustment screen — Allows for setting each drum, travel, and swing system maximum operating speed and swing torque.
- Accessory (ACC) system — Provides accessory system component status information.
- Wireless screen — Provides load link and hand-held radio remote information.

- Crane mode screen — Allows for selecting crane mode of operation.
- [Table 3-13](#) contains bank identifier numbers.

### Drum 1

HANDLE	+/-0 %	0.0 V	PRESS	0 psi	
PUMP A	+/-0 %	0 CS	SPEED	+/-0 rpm	
PUMP B	+/-0 %		BRAKE	0	
MOTOR	0 %		DOS	0	DRUM 1

DRUM 1 screen displays the following information:

- Control HANDLE command in percent from neutral with + raise and - lower.
- The normal operating voltage (V) outputs of the control handle range is 2.4 to 0.5 volts to raise a load and 2.6 to 4.5 volts to lower a load.

**NOTE:** With drum control handle D function, raise and lower voltage is reversed.

- Control handle Center Switch (CS) command with 0 neutral and 1 active.
- PUMP A and B command in percent from neutral with + raise and - lower for each pump.
- MOTOR command in percent with 0% maximum displacement and 100% minimum displacement.
- Measured hoist PRESSURE (psi) at high side pressure port.
- Measured drum SPEED in RPM with + raise and - lower.
- Park BRAKE command with 0 engaged and 1 released.
- DOS (digital output status) displays a binary number (or total) if digital output signal is disabled to: pump A - drum 1 (1), pump B - drum 1 and 3 (2), motor 1 (4), motor 2 (8) or drum brake (16).

### Drum 2

HANDLE	+/-0 %	0.0 V	PRESS	0 psi	
PUMP A	+/-0 %	0 CS	SPEED	+/-0 rpm	
PUMP B	+/-0 %		BRAKE	0	
MOTOR	0 %		DOS	0	DRUM 2

DRUM 2 screen displays the following information:

- Control HANDLE command in percent from neutral with + raise and - lower.
- The normal operating voltage (V) outputs of the control handle range is 2.4 to 0.5 volts to raise a load and 2.6 to 4.5 volts to lower a load.

**NOTE:** With drum control handle D function, raise and lower voltage is reversed.

- Control handle Center Switch (CS) command with 0 neutral and 1 active.
- PUMP A and B command in percent from neutral with + raise and - lower for each pump.
- MOTOR command in percent with 0% maximum displacement and 100% minimum displacement.
- Measured hoist PRESSURE (psi) at high side pressure port.
- Measured drum SPEED in RPM with + raise and - lower.
- Park BRAKE command with 0 engaged and 1 released.
- DOS (digital output status) displays a binary number (or total) if digital output signal is disabled to: pump A - drum 2 (1), pump B - drum 2 and 5 (2), motor 1 (4), motor 2 (8), or drum brake (16).

### Drum 3

HANDLE	+/-0 %	0.0 V	PRESS	0 psi	
PUMPA	+/-0 %	0 CS	SPEED	+/-0 rpm	
			BRAKE	0	
MOTOR	0 %		DOS	0	DRUM 3

DRUM 3 screen displays the following information:

- Control HANDLE command in percent from neutral with + raise and - lower.
- The normal operating voltage (V) outputs of the control handle range is 2.4 to 0.5 volts to lower a load and 2.6 to 4.5 volts to raise a load.

**NOTE:** With drum control handle D function, raise and lower voltage is reversed.

- Control handle Center Switch (CS) command with 0 neutral and 1 active.
- PUMP A command in percent from neutral with + raise and - lower.
- MOTOR command in percent with 0% maximum displacement and 100% minimum displacement.
- Measured hoist PRESSURE (psi) at high side pressure port.
- Measured drum SPEED in RPM with + raise and - lower.
- Park BRAKE command with 0 engaged and 1 released.
- DOS (digital output status) displays a binary number (or total) if digital output signal is disabled to: pump A - drum 1 and 3 (1), motor (2), brake (4) or diverter - drum 1 and 3 (8).

### Drum 4

HANDLE	+/-0 %	0.0 V	PRESS	0 psi	
PUMPA	+/-0 %	0 CS	SPEED	+/-0 rpm	
PUMP B	+/-0 %		BRAKE	0	
MOTOR	0 %		DOS	0	DRUM 4

DRUM 4 screen displays the following information:

- Control HANDLE command in percent from neutral with + raise and - lower.
- The normal operating voltage (V) outputs of the control handle range is 2.4 to 0.5 volts to raise a load and 2.6 to 4.5 volts to lower a load.

**NOTE:** With drum control handle D function, raise and lower voltage is reversed.

- Control handle Center Switch (CS) command with 0 neutral and 1 active.
- PUMP A and B command in percent from neutral with + raise and - lower for each pump.
- MOTOR command in percent with 0% maximum displacement and 100% minimum displacement.
- Measured hoist PRESSURE (psi) at high side pressure port.
- Measured drum SPEED in RPM with + raise and - lower.
- Park BRAKE command with 0 engaged and 1 released.
- DOS (digital output status) displays a binary number (or total) if digital output signal is disabled to: pump A - pump 1 (1), pump B - pump 2 (2), motor 1 (4), motor 2 (8), drum brake (16) or drum pawl (32).

### Drum 5

HANDLE	+/-0 %	0.0 V	PRESS	0 psi	
PUMPA	+/-0 %	0 CS	SPEED	+/-0 rpm	
			BRAKE	0	
MOTOR	0 %		DOS	0	DRUM 5

DRUM 5 screen displays the following information:

- Control HANDLE command in percent from neutral with + raise and - lower.
- The normal operating voltage (V) outputs of the control handle range is 2.4 to 0.5 volts to raise a load and 2.6 to 4.5 volts to lower a load.

**NOTE:** With drum control handle D function, raise and lower voltage is reversed.

- Control handle Center Switch (CS) command with 0 neutral and 1 active.
- PUMP A command in percent from neutral with + raise and - lower.
- MOTOR command in percent with 0% maximum displacement and 100% minimum displacement.
- Measured hoist PRESSURE (psi) at high side pressure port.
- Measured drum SPEED in RPM with + raise and - lower.
- Park BRAKE command with 0 engaged and 1 released.
- DOS (Digital Output Status) displays a binary number (or total) if digital output signal is disabled to: pump A (1), not used (2), drum brake (4), drum pawl (8) or diverter (16).

### Drum 6

HANDLE	+/-0 %	0.0 V	PRESS	0 psi	
PUMPA	+/-0 %	0 CS	SPEED	+/-0 rpm	
			BRAKE	0	
MOTOR	0 %		DOS	0	DRUM 6

DRUM 6 screen displays the following information:

- Control HANDLE command in percent from neutral with + raise and - lower.
- The normal operating voltage (V) outputs of the control handle range is 2.4 to 0.5 volts to raise a load and 2.6 to 4.5 volts to lower a load.

**NOTE:** With drum control handle D function, raise and lower voltage is reversed.

- Control handle Center Switch (CS) command with 0 neutral and 1 active.
- PUMP A command in percent from neutral with + raise and - lower.
- MOTOR command in percent with 0% maximum displacement and 100% minimum displacement.
- Measured hoist PRESSURE (psi) at high side pressure port.
- Measured drum SPEED in RPM with + raise and - lower.
- Park BRAKE command with 0 engaged and 1 released.
- DOS (Digital Output Status) displays a binary number (or total) if digital output signal is disabled to: pump A (1), motor (2), drum brake (4) or drum pawl (8).

### Swing (Crane)

**NOTE:** Swing lock is not available on current production.

HANDLE	+/-0 %	0.0 V	RT PRES	0 psi	
PUMP	+/-0 %	0 CS	LT PRES	0 psi	
BRAKE	0	0 psi	DOS	0	
LOCK	0				SWING

The SWING screen displays the following information:

- Control HANDLE command in percent from neutral with + right and - left.
- The normal operating voltage (V) outputs of the control handle range is 2.4 to 0.5 volts for left swing and 2.6 to 4.5 volts for right swing.
- Control handle Center Switch (CS) command with 0 neutral and 1 active.
- PUMP command in percent from neutral with + right and - left.
- Park BRAKE command with 0 engaged and 1 released.
- Swing Brake Pressure (cranes without swing lock).
- Swing LOCK command with 0 engaged and 1 released. (cranes with swing lock).
- Measured pump RT PRES (psi) when swinging right.
- Measured pump LT PRES (psi) when swinging left.
- DOS (Digital Output Status) displays a binary number (or total) if the digital output signal is disabled to: pump 1 (1), pump 2 (2), swing brake (4), swing lock in (8) or swing lock out (16).

### Trk (Travel)

	LEFT	RIGHT	BRAKE	0
HANDLE	+/-0 % 0.0 V	+/-0 % 0.0 V	MOTOR	0
PUMP	+/-0 % 0 CS	+/-0 % 0 CS	CRUISE	0
PRES	0 psi	0 psi	DOS	0 TRK

The right and left TRK (Travel) screen displays the following information:

- Control HANDLE command in percent from neutral with + forward and - reverse.
- The normal operating voltage (V) outputs of the control handle range 2.6 to 4.5 volts for forward and 0.5 to 2.4 volts for reverse.
- Control handle Center Switch (CS) command with 0 neutral and 1 active.
- Left or right PUMP command in percent from neutral with + forward and - reverse.
- Measured track PRESS (psi) at right or left crawler track.
- Park BRAKE command with 0 engaged and 1 released.
- MOTOR command with 0 high speed/minimum displacement and 1 low speed/maximum displacement.
- CRUISE indicates status of travel cruise with 1 engaged and 0 disengaged.
- DOS (Digital Output Status) displays a binary number (or total) if the digital output signal is disabled to: right pump (1), left pump (2), travel brake (4), or motor (8).

### FCN (Front Console Node)

DI BANKS:	72	8	33	15
DO BANKS:	223	0		
TF BANKS:	000	000	000	000
				FCN

The status of the digital inputs and outputs of the front console controller is displayed in the FCN screen. Each bank can indicate the state of up to 255 individual digital inputs or outputs. The FCN screen displays the following information:

- Front console digital input DI BANKS 1, 2, 3, and 4.
- Front console digital output DO BANKS 5 and 6.
- Only programmers use TF BANKS 1, 2, 3, and 4.

Each individual input/output is assigned a number (identifier) in the binary system (powers of two). The identifiers of all inputs/outputs that are ON (active) for each bank are added for a total of 0 – 255. The number displayed for each bank is the **sum** of all identifiers that are ON in that bank. Each possible ON/OFF combination per bank has a unique total.

To determine the state of an individual digital input or output (crane component), find the individual crane component in [Table 3-11](#) or [Table 3-12](#), for example: Seat Switch **FCN-3-1**.

- The first part of the Code Number **FCN** indicates that the individual input or output is located in the FCN computer.

**NOTE:** If the Code Number starts with CAN, see CAN screen for input/output.

- The second part of the Code Number **3** is the **bank** where the individual information is shown on the FCN screen.
- The third part of the Code Number **1** is the item **identifier**.

To determine the state of the individual input/output in a bank, find the number displayed for the bank in the numbered column of [Table 3-13](#). In the corresponding row the identifier numbers that are ON (active) in the bank are shaded. In the above example if 1 is shaded the Seat Switch is ON (active).

**Node Identification**

Node Number	Node
1	Master (Front Console)
2	Handles and Cab Controls
3	Drum 3 and Pressure Senders
4	Jacking, Connecting Pins, and Mast
5	Alarms, Limits and Pump Controls
6	Drums 2, 4, 5 & Adapter Frame Pins
7	Swing and Auto Lube
8	Drum 1 and Drum 6
9	MAX-ER (optional)
0	Engine
20	Boom Top (not shown)
21	Luffing or Fixed Jib Top (not shown)

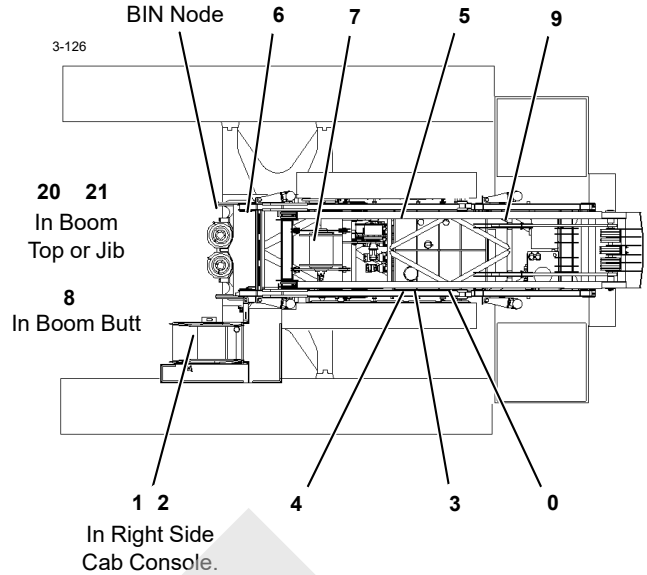

**FIGURE 3-43**

**CAN (Can Bus)**

STATUS 033	000	HIST	000	000	ENG	12
*PACKET ID #	38		BOOM	16	W/L	1
BANKS 1 - 4:	55	0	178	0		
BANKS 5 - 8:	4	35	0	16	CAN	

The CAN screen displays digital inputs and outputs of the master node controller. The location of crane nodes are shown in [Figure 3-43](#). The CAN screen displays the following information:

- STATUS indicates possible active communication errors between nodes on two banks that should read 000. The binary system status numbers are shown in [Table 3-8](#).

If a communication error occurs (033 in bank one) see [Table 3-8](#) for bank identifier numbers (node-2 and node-7)

**Table 3-8 Communication Errors**

Bank 1	1 = Node 2	16 = Node 6
	2 = Node 3	32 = Node 7
	4 = Node 4	64 = Node 8
	8 = Node 5	128 = Node 0
Bank 2	1 = Node 9	2 = BIN Node

- HISTORY indicates errors since power was cycled. Communication errors correspond to above table.
- BOOM indicates what boom nodes may be available on the bus. Boom status should always display a number or an error exists (see [Table 3-9](#)).

**Table 3-9 Boom Error**

Boom Status	Node Number	Description
1	21	Luffing jib node with #44
8	21	Luffing jib node 79A or Fixed jib node 79A
16	20	Boom top node 55A or 79A
128	20 or 21	Indicates a node is present that is not currently identified.

- ENGINE displays engine ECM bus status that is for factory use only.
- W/L indicates what wireless receiver nodes can be available.
  - Number 1 is boom to load link
  - Number 2 is remote
- PACKET ID number — Move select/confirm switch to SELECT. Cursor appears next to Packet ID #. Scroll up or down to desired packet number to display packet item status.
- Digital input or digital output BANKS 1, 2, 3, and 4
- Digital input or digital output BANKS 5, 6, 7, and 8

Each individual input/output is assigned a number (identifier) in the binary system (powers of two). The identifiers of all inputs/outputs that are ON (active) for each bank are added for a total of 0 – 255. The number displayed for each bank is the **sum** of all identifiers that are ON in that bank. Each possible ON/OFF combination per bank has a unique total.

To determine a state of an individual digital input or output, find the individual crane component in [Table 3-11](#) or [Table 3-12](#), for example: Return Filter Alarm **CAN38-1-32**.

- The first part of the Code Number **CAN38** indicates that the individual input or output is located in packet **38** of the master CAN computer.

**NOTE:** If the Code Number starts with FCN, see FCN screen for the input/output.

- Select PACKET ID# **38** by moving select/confirm switch to SELECT and a cursor appears next to Packet ID #. Scroll up or down to desired packet number to display packet item status.

- The second part of Code Number **1** is **bank** where the individual information is shown on the CAN screen.
- The third part of the Code Number **32** is the item **identifier**.

To determine the state of the individual input/output in a bank, find the number displayed for the bank in the numbered column of [Table 3-13](#). In the corresponding row the identifier numbers that are ON (active) in the bank are shaded. In the above example if **32** is shaded the Return Filter Alarm is ON (active).

To exit CAN screen move select/confirm switch to SELECT and cursor disappears. Continue scrolling up or down to access next screen.

18001024



### Hydraulic System Calibration

See Hydraulic System Calibration Procedures in this section.

PRESSURE SENDER CAL	0%	0	0
CONTROL CAL	0%	0	
PUMP PRESSURE TEST	0%	0	
CHARGE PRESSURE		0	0

### Speed/Torque

See Function Speed/Torque Adjustment in this section.

DRUM 1 SPEED	25 %	DRUM 6 SPEED	25 %
DRUM 2 SPEED	50 %	TRAVEL SPEED	75 %
DRUM 3 SPEED	25 %	SWING SPEED	25 %
DRUM 4 SPEED	25 %	SWING TORQUE	60 %

### Accessory System

HANDLE	+/-0 %	ACC PRES	psi	
ACC VLV	-0 %	DM5 PRES	psi	
DM5 PMP	+/-0 %	DM5 SPD	rpm	
VALVES	256	ACCUM P	psi	ACC

The ACC system screen displays the following information:

- Drum 5 (mast hoist) control HANDLE command in percent from neutral with + raise and - lower
- Accessory valve (ACC VLV) command in percent
- Drum 5 (mast hoist) pump (DM5 PMP) command in percent from neutral with + raise and - lower
- Accessory system pressure (ACC PRES) in psi
- Drum 5 (mast hoist) pump pressure (DM5 PRES) in psi
- Drum 5 (mast hoist) drum speed (DM5 SPD) in RPM
- Accumulator system pressure (ACCUM PRES) in psi
- VALVES - displays binary number of system components that are active in bank:

**Bank 1:**

- 1 = Jacking command
- 2 = Rotating frame command
- 4 = Mast raise switch and mast hoist control handle command is OFF
- 8 = Mast lower switch and mast hoist control handle command is OFF
- 16 = Boom hinge pins in switch

- 32 = Boom hinge pins out switch
- 64 = Mast pins in switch
- 128 = Mast pins out switch
- 256 = Cab tilt up
- 512 = Cab tilt down
- 1028 = Raise mast arms from stored position
- 2056 = Lower mast arms to stored position
- 4096 = MAX-ER cylinder
- 8192 = Rigging winch command

### Wireless

*REMOTE TxID	0000				
SENSOR BANKS:	0	64	0	128	160
LOAD LINK TRAFFIC	0	0			
REMOTE TRAFFIC	0	0			WIRELESS

The WIRELESS screen displays the following information:

- REMOTE TxID - where the link identification code is entered and displayed. To enter a link identification code, press select. The cursor (\*) appears next to remote TxID. Press select again to enter identification code area. Scroll up or down to enter 0 to 9 and/or A to F, press select to move through each four positions.

- SENSOR BANKS - where the four banks listed below display information shown in table.

1. Link 1 information
2. Link 2 information
3. Link 3 information
4. Hand-held radio remote control information
5. Block Level control information

Binary Number	Information
1, 2, or 4	Disregard information displayed.
8	RF link suspect.
16	Configuration data corrupt.
32	Internal CPU error.
64	Sensor voltage out of range. (Not used with block level sensor)
128	Sensor battery low.

- LOAD LINK TRAFFIC where bank one is transmitter identification and bank two property code (weight code of link). The two banks work together and continuously display information for each load link in immediate area.





- REMOTE TRAFFIC where bank one is transmitter identification and bank two property code of hand-held radio remote. The two banks work together and continuously display information for each radio remote in immediate area.

**NOTE:** Cranes with 2.4 Ghz wireless systems will not display traffic information.

**Block Level Sensor**

*BLOCK LEVEL SENSOR		
BLOCK ANGLE	+ 3.43 DEG	
DRUM 1 PUMP	30 %	
DRUM 2 PUMP	31 %	LEVEL

The LEVEL screen displays the following information:

**BLOCK LEVEL SENSOR** - where the block identification code is entered and displayed. To enter a block identification code, press select. The cursor (\*) appears next to Block Level Sensor. Press select again to enter identification code area. Scroll up or down to enter 0 to 9, press select to move through each four positions.

**BLOCK ANGLE** - where the block angle is displayed. A block level fault occurs if the maximum block angle for parts of line is exceeded:

Angle in Degree	Parts of Line
10	16 or less
8.8	20
7.6	24
6.4	28
5.2	32
4.0	36

**Crane Mode**

Crane Mode - STANDARD	
PROG M0000000.ONP	CON 000000

The crane mode screen displays the selected crane mode:

- Crane mode
- PROG is computer program version
- CON is computer and crane configuration code

**Hydraulic Fan (Tier 4 only)**

PRESS	000	PSI
PUMP	0	%
STATUS	0	
HYRAULIC FAN		

The hydraulic fan screen displays the following information for the Tier 4 hydraulic fan system:

- **PRESS** – Fan system pressure. Increased cooling demand and increased engine speed will increase this pressure.
- **PUMP** – Displays the current pump command. This will range from 5 to 100% and change in response to cooling demand and engine speed.
- **STATUS** – Displays the error status of the fan system:
  - 0 = no fault
  - Bit 1 = fan pressure transducer out of range
  - Bit 2 = fan control valve digital output fault
  - Bit 3 = fault is set if fan pressure is below 500 psi (34,5 bar) after the system is initialized. Will cause the backup coil to energize and try to fully stroke the pump.

## MAX-ER Attachment

### Crane Mode Selector — Crane with Swing Lock

#### CAUTION

##### Avoid Damage to Swing Drive Train!

TURN OFF swing park before attempting to travel with MAX-ER attachment connected to crane.

For MAX-ER operation, one of the following modes must be selected and confirmed in addition to the desired main mode (standard, luffing, etc.).

- **MAX-ER** for all load handling operations with the MAX-ER attachment.
- **TRAY ATTACHED** for operation when the MAX-ER mode is off, but the tray is attached (as during setup).

The operator shall confirm the desired operating mode at start-up:

- **M** = MAX-ER Mode
- **TA** = Tray Attached Mode

Additionally on cranes with swing locks, after confirming the desired operating mode, the following question is asked on the second line of the display (Figure 3-44):

#### Is Maxer Attached?

The operator shall then select either of the following answers with the confirm switch:

- Is Maxer Attached? **NO**
- Is Maxer Attached? **YES**

If the operator tries to travel with either mode on — MAX-ER or Tray Attached — the SWING PARKED operating fault will come on. The operator shall **turn off swing park** before attempting to travel with the MAX-ER attachment connected to the crane. Otherwise, **major structural damage will occur to swing drive train.**

\*M = MAX-ER Mode  
TA = Tray Attached Mode

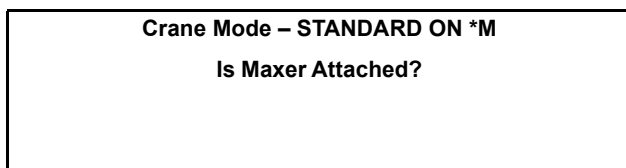

Confirm either:  
**Is Maxer Attached? YES**  
OR  
**Is Maxer Attached? NO**

FIGURE 3-44

### Crane Mode Selector — Crane Without Swing Lock

#### CAUTION

##### Avoid Damage to Swing Drive Train!

TURN OFF swing park before attempting to travel with MAX-ER attachment connected to crane.

For MAX-ER operation, the following **MAX-ER** mode must be selected and confirmed in addition to the desired main mode (standard, luffing, etc.).

The operator shall confirm the operating mode at start-up.

Traveling with the MAX-ER mode on and the swing brake applied, the SWING PARKED operating fault will come on and the crane will not travel. **Turn off swing park** before attempting to travel with the MAX-ER attachment connected to the crane.

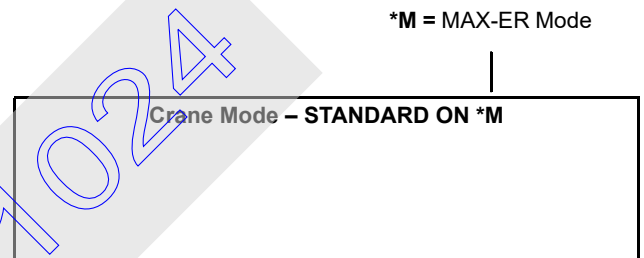

FIGURE 3-45

**NOTE:** If you don't install the shorting plug at the MAX-ER junction box (Figure 3-46) when you remove the MAX-ER attachment, the controller will assume the MAX-ER is still attached.

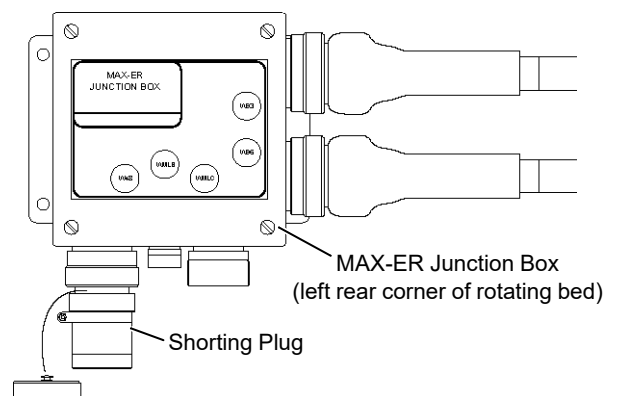

FIGURE 3-46

#### MAX-ER On

Once selected and confirmed, the modes will appear on the digital display as shown in Figure 3-44 and Figure 3-45. The **\*M** on the right end of the screen indicates that the MAX-ER mode is on.

When the MAX-ER mode is on:

- The load sensing pins (counterweight and mast) measure backhitch tension created by the lifted load.
- The load sensing pins send a proportional voltage signal to the programmable controller.

The programmable controller activates the crane’s electric and hydraulic systems to automatically extend and retract the counterweight cylinders (raise and lower counterweight assembly) in response to changes in strap tension as shown in [Table 3-10](#).

**Table 3-10 Backhitch Tension Cylinder Response**

Backhitch Tension U.S. Tons	Counterweight Cylinders	Counterweight Carrier
50	Retract	Raise
40	Stop Raising Tray <i>(Tray will also stop rising if limit switch at either cylinder is tripped open.)</i>	
10	Extend	Lower
15	Stop Lowering Tray	



**DIGITAL INPUT AND OUTPUT ITEM TABLES**

Table 3-11 and Table 3-12 identify selected component digital inputs and digital outputs used on the crane. The Code Number indicates the computer packet number (CAN) or front console computer location (FCN).

See CAN screen if the item Code Number has a CAN prefix or to FCN screen if item Code Number has a FCN prefix. Table 3-13 lists the identifier numbers that are ON (active) for each bank.

**Table 3-11 Digital Inputs**

CAN Packet Number	Item Description (Node Number)	CAN Packet Number	Item Description (Node Number)
CAN57-1-1	Handle A Direction Signal (2)	FCN-1-1	Drum 6 Park Switch - On (1)
CAN57-1-2	Handle D Direction Signal (2)	FCN-1-2	Crane Mode Confirm Switch (1)
CAN57-1-4	Swing Holding Brake Switch (2)	FCN-1-4	Drum 1 Park Switch - On (1)
CAN57-1-8	Swing Handle Direction Signal (2)	FCN-1-8	Crane Display Scroll Up Switch (1)
CAN57-1-16	Swing Handle Dead Man Option (2)	FCN-1-16	Drum 2 Park Switch - On (1)
CAN57-2-1	Left Track Direction Signal (2)	FCN-1-32	Crane Display Scroll Down Switch (1)
CAN57-2-2	Handle B Direction Signal (2)	FCN-1-64	Travel Park Switch - On (1)
CAN57-2-4	Handle C Direction Signal (2)	FCN-1-128	Cab Tilt Up Switch (1)
CAN57-2-8	Right Track Direction Signal (2)	FCN-2-1	RCL Mode Confirm Switch (1)
CAN59-1-4	Super Charge Hydraulic Pressure (3) (Prior to s/n 18001082)	FCN-2-2	Drum 5 Park Switch - On (1)
CAN59-1-128	Drum 3 Minimum Bail Limit Switch (3)	FCN-2-4	Limit Bypass Switch (1)
CAN61-1-128	Drum 2 Minimum Bail Limit Switch (6)	FCN-2-8	RCL Display Scroll Up Switch (1)
CAN65-1-128	Accessory System Hydraulic Pressure Sw. (7)	FCN-2-32	RCL Display Scroll Down Switch (1)
CAN67-1-4	Counterweight Limit Switch - Right Side (9)	FCN-2-64	Travel Cruise Switch - On (1)
CAN67-1-8	Counterweight Limit Switch - Left Side (9)	FCN-3-1	Seat Switch (1)
CAN69-1-4	Hydraulic Fluid Level (5)	FCN-3-2	Cab Tilt Down Switch (1)
CAN69-1-8	Charge Filter 1 Alarm (5) (Prior to s/n 18001082) Return Filter 2 Alarm (S/N 18001082 and newer)	FCN-3-8	A/C Compressor Switch - On (1)
CAN69-1-128	Maximum Boom Angle Limit Switch (5)	FCN-3-32	Engine Start (1)
CAN71-1-128	Drum 1 Minimum Bail Limit Switch (8)	FCN-3-64	Crane Mode Select Switch (1)
CAN132-6-64	Block Up Limit Luffing/Jib Lower Pt. (#44) (21)	FCN-3-128	Drum 4 Park Switch - On (1)
CAN132-6-128	Block Up Limit Luffing/Jib Upper Pt. (#44) (21)	FCN-4-8	Travel 2-Speed Switch (1)
CAN135-6-64	Block Up Limit Luffing/Jib Lower Pt. (#79A) (21)	FCN-4-32	Swing Park Brake - On (1)
CAN135-6-128	Block Up Limit Luffing/Jib Upper Pt. (#79A) (21)	FCN-4-64	RCL Mode Select Switch (1)
CAN136-6-64	Block Up Limit Boom Lower Point (20)	FCN-4-128	Drum 3 Park Switch - On (1)
CAN136-6-128	Block Up Limit Boom Upper Point (20)		

**Table 3-12 Digital Outputs**

CAN Packet Number	Item Description (Node Number)	CAN Packet Number	Item Description (Node Number)
CAN32-1-1	Cab Base RCL Beacon/Alarm (2)	CAN32-3-128	Handle C Lower Direction (2)
CAN32-1-2	Handle A Rotation Indicator (2)	CAN33-1-1	Super Charge Hydraulic Pressure (3)
CAN32-1-4	Handle C Rotation Indicator (2)	CAN33-1-2	Drum 2/5 Pressure Sender (3)
CAN32-1-8	Front Wiper Switch (2)	CAN33-1-4	Drum 1/3 Pressure Sender (3)
CAN32-1-16	Overhead Wiper Switch (2)	CAN33-1-8	Accessory System Pressure Sender (3)
CAN32-1-32	Handle D Rotation Indicator (2)	CAN33-1-16	Left Track Pressure Sender (3)
CAN32-1-64	Handle B Rotation Indicator (2)	CAN33-1-32	Right Track Pressure Sender (3)
CAN32-1-128	Handle Displays (2)	CAN33-1-64	Drum 3 Motor Control (3)
CAN32-2-1	Power to Switches 3 (2)	CAN33-1-128	Drum 3 Brake Solenoid (3)
CAN32-2-2	Handle D Lower Direction (2)	CAN33-2-1	Pump Drive Cooler Pressure (3)
CAN32-2-4	Right Travel Handle Reverse Direction (2)	CAN33-2-2	Drum 3 Minimum Bail Limit Switch (3)
CAN32-2-16	Power to Switches 1 (2)	CAN33-2-4	Drum 1/3 Pump Control - Raise (3)
CAN32-2-32	Left Travel Handle Forward Direction (2)	CAN33-2-8	Drum 1/3 Pump Control - Lower (3)



CAN Packet Number	Item Description (Node Number)	CAN Packet Number	Item Description (Node Number)
CAN32-2-64	Left Travel Handle Reverse Direction (2)	CAN33-2-16	Drum 2/5 Pump Control - Raise (3)
CAN32-2-128	Power to Switches 2/Seat Switch (2)	CAN33-2-32	Drum 2/5 Pump Control - Lower (3)
CAN32-3-1	Right Travel Handle Forward Direction (2)	CAN33-2-64	Drum 2 Pump Control - Lower (3)
CAN32-3-2	Handle D Raise Direction (2)	CAN33-2-128	Drum 2 Pump Control - Raise (3)
CAN32-3-4	Handle B Raise Direction (2)	CAN33-3-1	Drum 1/3 (opt.) Pump Control - Raise (3)
CAN32-3-8	Handle B Lower Direction (2)	CAN33-3-2	Drum 1/3 (opt.) Pump Control - Lower (3)
CAN32-3-16	Travel Cruise Switch (2)	CAN33-3-4	Left Track Pump Control - Forward (3)
CAN32-3-32	Handle C Raise Direction (2)	CAN33-3-8	Left Track Pump Control - Reverse (3)
CAN32-3-64	Foot Throttle Output (2)	CAN33-3-16	Swing 1 Pump Control - Left (3)
CAN33-3-32	Swing 1 Pump Control - Right (3)	CAN37-1-32	CWT Right Cylinder - Extend Solenoid (9)
CAN34-1-2	Drum 5 Brake Solenoid (6)	CAN37-1-64	Power to MAX-ER Remote Control (9)
CAN34-1-4	Drum 5 Pawl Out Solenoid (6)	CAN37-1-128	Power to MAX-ER Remote Control (9)
CAN34-1-8	Drum 5 Pawl In Solenoid (6)	CAN37-2-1	Power to MAX-ER Remote Control (9)
CAN34-1-64	Drum 2 Motor Control 1 (6)	CAN37-2-2	Power to MAX-ER Remote Control (9)
CAN34-1-128	Drum 2 Motor Control 2 (6)	CAN38-1-1	Hydraulic Vacuum Switch (5)
CAN34-2-1	Drum 2 Brake Solenoid (6)	CAN38-1-2	Hydraulic Fluid Level/Charge Filter 1 Alarm (5) (Prior to s/n 18001082)
			Hydraulic Fluid Level/Return Filter 2 Alarm (S/N 18001082 and newer)
CAN34-2-4	Rear Adapter Frame Pins Engage (6)	CAN38-1-4	Hydraulic Fluid Low Temperature Switch (5)
CAN34-2-8	Rear Adapter Frame Pins Disengage (6)	CAN38-1-8	Charge Filter 2 Alarm (5) (Prior to s/n 18001082)
			Return Filter 3 Alarm (S/N 18001082 and newer)
CAN34-2-16	Front Adapter Frame Pins Engage (6)	CAN38-1-16	Hydraulic Fluid High Temperature Switch (5)
CAN34-2-32	Front Adapter Frame Pins disengage (6)	CAN38-1-32	Return Filter Alarm Switch (5)
CAN34-3-4	Drum 4 Pawl In Motor (6)	CAN38-1-64	Drum 6 Pressure Sender (5)
CAN34-3-8	Drum 4 Pawl Out Motor (6)	CAN38-1-128	Drum 4 Pressure Sender (5)
CAN34-3-16	Drum 4 Motor Control 1 (6)	CAN38-2-1	Hydraulic Pumps Case Heat (5)
CAN34-3-32	Drum 4 Motor Control 2 (6)	CAN38-2-2	Swing and Travel Alarm (5)
CAN34-3-64	Drum 4 Brake Solenoid (6)	CAN38-2-4	Right Track Pump Control - Forward (5)
CAN35-1-1	Mast Pins Engage Solenoid (4)	CAN38-2-8	Right Track Pump Control - Reverse (5)
CAN35-1-2	Mast Pins Disengage Solenoid (4)	CAN38-2-16	Drum 6 Pump Control -Raise (5)
CAN35-1-4	Boom Pins Engage Solenoid (4)	CAN38-2-32	Drum 6 Pump Control - Lower (5)
CAN35-1-8	Boom Pins Disengage Solenoid (4)	CAN38-2-128	Pump Drive Cooler 1 (5)
CAN35-1-16	Cab Tilt - Down Solenoid (4)	CAN38-3-1	Drum 4A Pump Control -Raise (5)
CAN35-1-32	Cab Tilt - Up Solenoid (4)	CAN38-3-2	Drum 4A Pump Control -Lower (5)
CAN35-1-64	Drum 3 Diverter Solenoid (4)	CAN38-3-4	Drum 4B Pump Control -Raise (5)
CAN35-1-128	Drum 5 Diverter Solenoid (4)	CAN38-3-8	Drum 4B Pump Control -Lower (5)
CAN35-2-1	Mast Raise Solenoid (4)	CAN38-3-16	Swing 2 (optional) Pump Control - Left (5)
CAN35-2-2	Mast Lower Solenoid (4)	CAN38-3-32	Swing 2 (optional) Pump Control - Right (5)
CAN35-2-4	Drum 7 Payout Solenoid (4)	CAN38-3-64	Pump Drive Cooler 2 (5)
CAN35-2-8	Drum 7 Haul In Solenoid (4)	CAN38-3-128	Accessory System Proportional Solenoid (5)
CAN35-2-16	Right Front Jack Extend Solenoid (4)	CAN39-1-64	Drum 1 Motor Control 1 (8)
CAN35-2-32	Right Front Jack Retract Solenoid (4)	CAN39-1-128	Drum 1 Motor Control 2 (8)
CAN35-2-64	Left Front Jack Retract Solenoid (4)	CAN39-2-1	Drum 1 Brake Solenoid (8)
CAN35-2-128	Left Front Jack Extend Solenoid (4)	CAN39-2-2	Drum 1 Minimum Bail Limit Switch (8)
CAN35-3-4	Right Rear Jack Extend Solenoid (4)	CAN39-2-4	Drum 6 Pawl Motor Control (8)
CAN35-3-8	Right Rear Jack Retract Solenoid (4)	CAN39-2-8	Drum 6 Brake Solenoid (8)
CAN35-3-16	Left Rear Jack Extend Solenoid (4)	CAN39-2-16	Drum 6 Pawl In Motor (8)
CAN35-3-32	Right Rear Jack Retract Solenoid (4)	CAN39-2-32	Drum 6 Pawl Out Motor (8)

CAN Packet Number	Item Description (Node Number)	CAN Packet Number	Item Description (Node Number)
CAN36-1-64	Swing Left Pressure Sender (7)		
CAN36-1-128	Swing Right Pressure Sender (7)	FCN-5-1	Operating Limit Alarm (Beeper) and L.E.D. (1)
CAN36-2-2	Accessory System Hydraulic Pressure Sw. (7)	FCN-5-4	RCL Warning L.E.D. (1)
CAN36-2-4	Swing Brake Solenoid (7)	FCN-5-32	RCL Caution L.E.D. (1)
CAN36-2-8	Swing Lock Out Solenoid (7)	FCN-5-64	RCL Fault Alarm in Cab (1)
CAN36-2-16	Swing Lock In Solenoid (7)	FCN-5-128	System Fault Alarm (Buzzer) and L.E.D. (1)
CAN36-2-32	Travel 2-Speed Solenoid (7)	FCN-6-2	Handle B Display (1)
CAN36-3-4	Travel Brake Solenoid (7)	FCN-6-4	Engine Diagnostics (Red L.E.D.) (1)
CAN36-3-8	Track Auto Lube Solenoid (7)	FCN-6-8	Handle D Display (1)
CAN36-3-16	Swing Bearing Auto Lube Solenoid (7)	FCN-6-16	Handle A Display (1)
CAN37-1-2	CWT Left Cylinder - Retract Solenoid (9)	FCN-6-32	Engine Diagnostics (White L.E.D.) (1)
CAN37-1-4	Counterweight Limit Switch (9)	FCN-6-64	Handle C Display (1)
CAN37-1-8	CWT Right Cylinder - Retract Solenoid (9)	FCN-6-128	Engine Diagnostics (Amber L.E.D.) (1)
CAN37-1-16	CWT Left Cylinder - Extend Solenoid (9)		

18001024

***THIS PAGE INTENTIONALLY LEFT BLANK***

18001024



## HYDRAULIC SYSTEM CALIBRATION PROCEDURES

### General

To ensure proper operation of the crane functions, the following items must be calibrated or tested at the intervals specified in this folio:

- Pressure Senders
- Controls (pump centers)
- Pump Pressure
- Charge Pressure

See [Figure 3-47](#) for identification of the controls used for calibration and testing.



### WARNING

#### Moving Load Hazard!

With engine running, crane functions (drums, boom hoist, swing, travel) can operate unexpectedly while system components are being calibrated or tested.

To prevent crane functions from moving, turn PARK ON for all crane functions before you perform calibration or testing procedures.

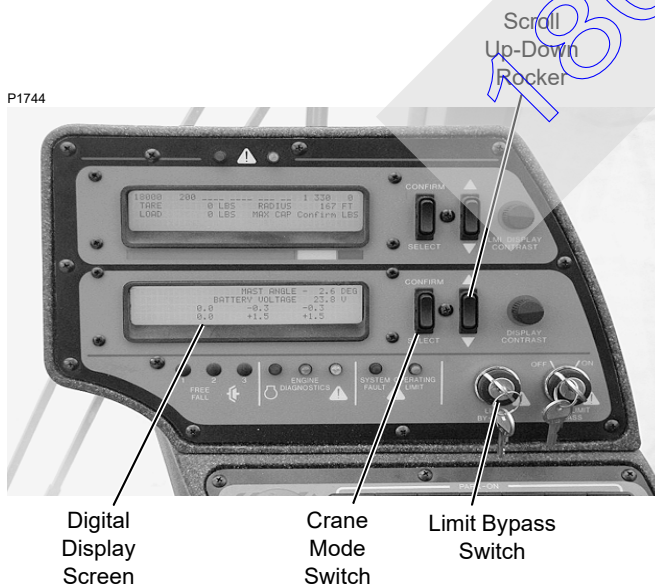

FIGURE 3-47

### Pressure Sender Calibration

See [Figure 3-47](#) and [Figure 3-48](#) for the following procedure.

The pressure sender line of the calibration screen indicates if each system's pressure sender null (0) is within 0.65-1.35 volts.

The pressure senders must be calibrated at the following intervals:

- When a new controller node is installed
- When a pump is replaced
- When a pump control (EDC or PCP) is replaced
- When a pressure sender is replaced
- When displayed pressure is not correct

Be aware that if there is any residual pressure in the system during the calibration process, the display pressure reading in the cab may not reflect actual system pressure. See Note on [page 3-72](#).

- Every 6 months

To perform pressure sender calibration, proceed as follows:

1. Stop engine and turn ignition switch to RUN position.
2. Access calibration screen shown below as follows:
  - a. Select and confirm SETUP mode to activate calibration program.
  - b. Turn LIMIT BYPASS switch clockwise and hold.
  - c. SCROLL UP at least one screen.
  - d. Continue to scroll up or down until calibration screen appears.
  - e. Press bottom of CRANE MODE switch until (\*) appears next to PRESSURE SENDER CAL.
  - f. Then press top end of CRANE MODE switch to CONFIRM. Calibration will start.
  - g. When calibration starts, percent (%) of completion is displayed on screen.
  - h. When calibration stops, check bank 1 and bank 2 binary numbers:
    - If 0 appears, all pressure senders have passed calibration.
    - If any number other than 0 appears in either bank, use the table in [Figure 3-48](#) to determine which senders have failed calibration.
    - Each pressure sender is assigned a number in the binary system (power of two). After running the calibration procedure, outputs that are ON (failed) for any sender, are added together. To identify the failed senders, find the binary

number displayed on the screen in the first column of [Table 3-13](#). All shaded boxes to the right of the number indicate senders that failed calibration. Troubleshoot the corresponding system to determine the cause of the fault

**NOTE:** The cause of a failed calibration or faulty display pressure reading in the cab may not be the pressure sender. The cause of the fault could be trapped air or hydraulic pressure in the system.

Before replacing a pressure sender, do the following:

- Perform pressure sender calibration steps.
- Attach an accurate hydraulic pressure gauge to the quick-coupler at the suspect pressure transducer (see Section 2 of Service Manual).

- If pressure appears on the gauge, bleed the corresponding system so the gauge reads zero pressure.
- Repeat calibration steps and check pressure on the display in the cab with the engine running at idle — the display reading and the gauge reading should be the same.
- Before replacing a pressure sender, check the signal voltage at the sender. It should be 1.0 volt against ground at 0 psi.

3. Proceed to next procedure, or exit calibration screen by pressing bottom of CRANE MODE switch. Cursor (\*) will disappear from screen.

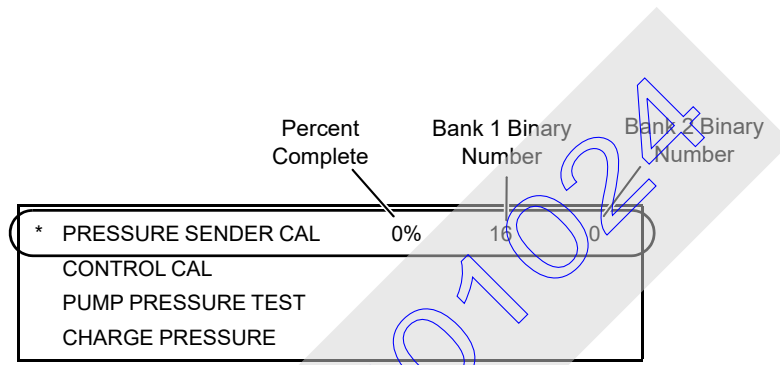

Binary Number	Pressure Sender (Bank 1)	Binary Number	Pressure Sender (Bank 2)
1	Drum 1/3 (Main Hoist)	4	Pump Drive
2	Not Used	8	Swing Brake
4	Drum 2/5 (Main Hoist)	16	Fan Control
8	Accessory System		
16	Drum 4 (Boom Hoist)		
32	Drum 6 (Luffing Hoist)		
64	Left Track		
128	Right Track		

FIGURE 3-48

### Control Calibration

See [Figure 3-47](#) and [Figure 3-49](#) for the following procedure.

The control line of the calibration screen indicates whether the pump centers are within the allowable range of each pump's Electric Displacement Control (EDC). The allowable range is 5-25% pump command signal for the hoist pumps, and 2.5-20% in each direction for the swing pump.

The controls must be calibrated at the following intervals:

- When a new controller node is installed
- When a pump is replaced
- When a pump control (EDC or PCP) is replaced
- When there is a noticeable time increase to engage a crane function when handle is moved from off
- Every 6 months

To perform control system calibration, proceed as follows:

1. Turn PARK ON for all crane functions (drums, boom hoist, swing, travel).
2. Start engine. It is normal for yellow operating limits light to come on during this procedure.
3. Access calibration screen shown below as follows:
  - a. Select and confirm SETUP mode to activate calibration program.
  - b. Turn LIMIT BYPASS switch clockwise and hold.
  - c. SCROLL UP at least one screen.
  - d. Continue to scroll up or down until calibration screen appears.

- e. Press bottom of CRANE MODE switch until (\*) appears next to CONTROL CAL.
- f. Increase engine speed to HIGH IDLE.  
Engine must be running at high idle before calibration will start.  
Calibration will stop if engine speed is decreased during calibration.
- g. Press top end of CRANE MODE switch to CONFIRM. Calibration will start.
- h. When calibration starts, percent (%) of completion is displayed on screen.
- i. When calibration stops, check binary number:
  - If 0 appears, all controls have passed calibration.
  - If any number other than 0 appears, use [Table 3-13](#) to determine which controls have failed calibration.
  - Each control is assigned a number in the binary system (power of two). After running the calibration procedure, outputs that are ON (failed) for any control, are added together. To identify the failed controls, find the binary number displayed on the screen in the first column of [Table 3-13](#). All shaded boxes to the right of the number indicate controls that failed calibration. Troubleshoot the particular system to determine the cause of the fault.
4. Proceed to next procedure, or exit calibration screen by pressing bottom of CRANE MODE switch. Cursor (\*) will disappear from screen.

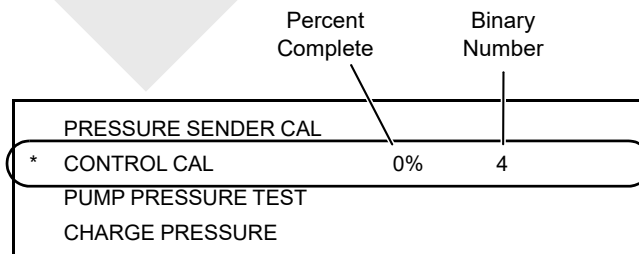

Binary Number	Pressure Sender (Bank 1)	Binary Number	Pressure Sender (Bank 2)
1	Main Hoist 1	8	Swing Left
2	Main Hoist 2	16	Swing Right
4	Boom Hoist	32	Luffing Hoist

FIGURE 3-49

## Pump Pressure Test

See [Figure 3-47](#) and [Figure 3-50](#) for the following procedure.

The pump pressure line of the calibration screen cycles through the hoist pumps to make sure each pump is capable of producing 6,000 psi (414 bar). This test is generally used only as a shop procedure on new cranes. It can also be used as a quick way to test hydraulic components in the primary hydraulic circuits.

**CAUTION:** This test must be done by a qualified service technician and only when deemed necessary.



### WARNING

#### High Pressure Hazard!

This test generates maximum pressure in the main hydraulic circuits. Defective brakes may allow unintended motion during test. Move the crane to an area where such motion is not a hazard.

Use a signal person to monitor functions operator cannot see.

Be prepared to stop engine if unintended motion occurs.

To perform pump pressure test, proceed as follows:

1. Turn PARK ON for all crane functions (drums, boom hoist, swing, travel).
2. Start engine. It is normal for yellow operating limits light to come on during this procedure.
3. Access calibration screen shown below as follows:
  - a. Select and confirm SETUP mode to activate calibration program.
  - b. Turn LIMIT BYPASS switch clockwise and hold.
  - c. SCROLL UP at least one screen.

- d. Continue to scroll up or down until calibration screen appears.
- e. Press bottom of CRANE MODE switch until (\*) appears next to PRESSURE TEST.
- f. Increase engine speed to:
  - HIGH IDLE, *field personnel*.
  - 1,350 RPM, MCC assembly personnel when checking out a new crane.

Engine must be running faster than 750 RPM before pump pressure test will start.

Pump pressure test will stop if engine speed is decreased during procedure.

- g. Press top end of CRANE MODE switch to CONFIRM. Testing will start.
- h. When testing starts, percent (%) of completion is displayed on screen.
- i. When testing stops, check binary number:
  - If 0 appears, all pumps have passed the test.
  - If any number other than 0 appears, use [Table 3-13](#) to determine which pumps have failed the test.

Each pump is assigned a number in the binary system (power of two). After running the pressure test, outputs that are ON (failed) for any pump, are added together. To identify the failed pumps, find the binary number displayed on the screen in the first column of [Table 3-13](#). All shaded boxes to the right of the number indicate pumps that failed testing. Troubleshoot the particular system to determine the cause of the fault.

4. Proceed to next procedure, or exit calibration screen by pressing bottom of CRANE MODE switch. Cursor (\*) will disappear from screen.

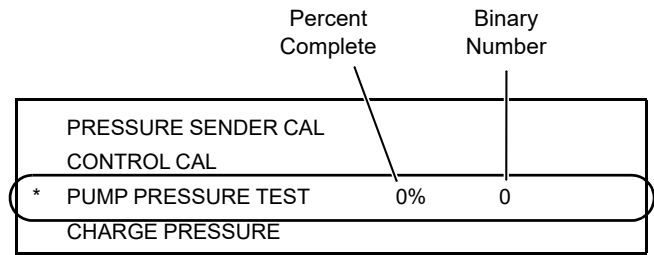

Binary Number	Pressure Sender (Bank 1)	Binary Number	Pressure Sender (Bank 2)
1	Main Hoist 1	4	Boom Hoist
2	Main Hoist 2	8	Luffing Hoist

18001024

FIGURE 3-50

### Charge Pressure Check

See [Figure 3-47](#) and [Figure 3-51](#) for the following procedure.

The charge pressure line of the calibration screen indicates if any charge pump is not within 275-400 psi (19-27 bar).

Charge pressure should be checked at the following intervals:

- When a new controller node is installed
- When a pump is replaced
- When a pump control (EDC or PCP) is replaced
- Every 6 months

To check charge pressure, proceed as follows:

1. Start and run engine at low idle.
2. Access calibration screen shown below as follows:
  - a. Turn LIMIT BYPASS switch clockwise and hold.
  - b. SCROLL UP at least one screen.

- c. Continue to scroll up or down until calibration screen appears.
- d. The fourth line of the screen indicates charge pressure:
  - If 0 appears, all charge pumps are okay.
  - If any number other than 0 appears, use [Table 3-13](#) to determine which pumps have failed the test.
  - Each pump is assigned a number in the binary system. Outputs that are ON (failed) for any pump, are added together. To identify the failed pumps, find the binary number displayed on the screen in the first column of [Table 3-13](#). All shaded boxes to the right of the number indicate pumps that have failed. Troubleshoot the particular system to determine the cause of the fault.

3. Proceed to next procedure, or exit calibration screen by pressing bottom of CRANE MODE switch. Cursor (\*) will disappear from screen.

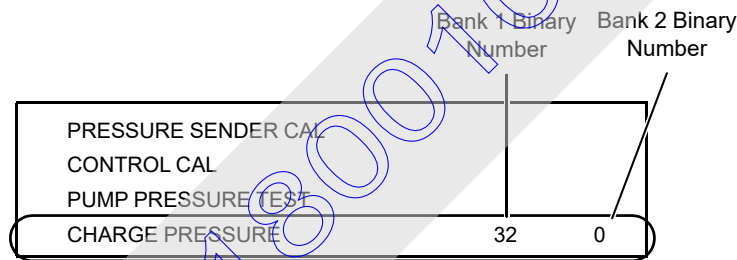

Binary Number	Charge Pump (Bank 1)	Binary Number	Charge Pump (Bank 2)
1	Drum 1/3 (Main Hoist)	1	Swing Left
2	Not Used	2	Swing Right
4	Drum 2/5 (Main Hoist)	4	High Pressure Accessory Accumulator
8	Accessory System		
16	Drum 4 (Boom Hoist)		
32	Drum 6 (Luffing Hoist)		
64	Left Track		
128	Right Track		

FIGURE 3-51

Table 3-13 Bank Identifier Numbers

	1	2	4	8	16	32	64	128
1	■							
2	■	■						
3	■	■						
4	■		■					
5	■	■						
6	■	■	■					
7	■	■	■					
8	■			■				
9	■	■						
10	■	■	■					
11	■	■	■					
12	■							
13	■	■						
14	■	■	■					
15	■	■	■					
16	■				■			
17	■	■						
18	■	■	■					
19	■	■	■					
20	■							
21	■	■						
22	■	■	■					
23	■	■	■					
24	■	■	■					
25	■							
26	■	■						
27	■	■	■					
28	■							
29	■	■						
30	■	■	■					
31	■	■	■					
32	■					■		
33	■	■						
34	■	■	■					
35	■	■	■					
36	■							
37	■	■						
38	■	■	■					
39	■	■	■					
40	■							
41	■	■						
42	■	■	■					
43	■	■	■					
44	■							
45	■	■						
46	■	■						
47	■	■						
48	■	■						
49	■	■						
50	■	■						
51	■	■						
52	■	■						
53	■	■						
54	■	■						
55	■	■						
56	■	■						
57	■	■						
58	■	■						
59	■	■						
60	■	■						
61	■	■						
62	■	■						
63	■	■						
64	■	■						
65	■	■						
66	■	■						
67	■	■						
68	■	■						
69	■	■						
70	■	■						
71	■	■						
72	■	■						
73	■	■						
74	■	■						
75	■	■						
76	■	■						
77	■	■						
78	■	■						
79	■	■						
80	■	■						
81	■	■						
82	■	■						
83	■	■						
84	■	■						
85	■	■						
86	■	■						
87	■	■						
88	■	■						
89	■	■						
90	■	■						
91	■	■						
92	■	■						
93	■	■						
94	■	■						
95	■	■						
96	■	■						
97	■	■						
98	■	■						
99	■	■						
100	■	■						
101	■	■						
102	■	■						
103	■	■						
104	■	■						
105	■	■						
106	■	■						
107	■	■						
108	■	■						
109	■	■						
110	■	■						
111	■	■						
112	■	■						
113	■	■						
114	■	■						
115	■	■						
116	■	■						
117	■	■						
118	■	■						
119	■	■						
120	■	■						
121	■	■						
122	■	■						
123	■	■						
124	■	■						
125	■	■						
126	■	■						
127	■	■						
128	■	■						
129	■	■						

Dark shaded boxes indicate ON; white boxes OFF.



Table 3-13 Bank Identifier Numbers (continued)

	1	2	4	8	16	32	64	128
130								
131								
132								
133								
134								
135								
136								
137								
138								
139								
140								
141								
142								
143								
144								
145								
146								
147								
148								
149								
150								
151								
152								
153								
154								
155								
156								
157								
158								
159								
160								
161								
162								
163								
164								
165								
166								
167								
168								
169								
170								
171								
172								

	1	2	4	8	16	32	64	128
173								
174								
175								
176								
177								
178								
179								
180								
181								
182								
183								
184								
185								
186								
187								
188								
189								
190								
191								
192								
193								
194								
195								
196								
197								
198								
199								
200								
201								
202								
203								
204								
205								
206								
207								
208								
209								
210								
211								
212								
213								
214								
215								

	1	2	4	8	16	32	64	128
216								
217								
218								
219								
220								
221								
222								
223								
224								
225								
226								
227								
228								
229								
230								
231								
232								
233								
234								
235								
236								
237								
238								
239								
240								
241								
242								
243								
244								
245								
246								
247								
248								
249								
250								
251								
252								
253								
254								
255								

Dark shaded boxes indicate ON; white boxes OFF.

Table 3-13 Bank Identifier Numbers (continued)

	1	2	4	8	16	32	64	128	256
256									
257									
258									
259									
260									
261									
262									
263									
264									
265									
266									
267									
268									
269									
270									
271									
272									
273									
274									
275									
276									
277									
278									
279									
280									
281									
282									
283									
284									
285									
286									
287									
288									
289									
290									
291									
292									
293									
294									
295									
296									
297									
298									

	1	2	4	8	16	32	64	128	256
299									
300									
301									
302									
303									
304									
305									
306									
307									
308									
309									
310									
311									
312									
313									
314									
315									
316									
317									
318									
319									
320									
321									
322									
323									
324									
325									
326									
327									
328									
329									
330									
331									
332									
333									
334									
335									
336									
337									
338									
339									
340									
341									

	1	2	4	8	16	32	64	128	256
342									
343									
344									
345									
346									
347									
348									
349									
350									
351									
352									
353									
354									
355									
356									
357									
358									
359									
360									
361									
362									
363									
364									
365									
366									
367									
368									
369									
370									
371									
372									
373									
374									
375									
376									
377									
378									
379									
380									
381									
382									
383									
384									

Dark shaded boxes indicate ON; white boxes OFF.

Table 3-13 Bank Identifier Numbers (continued)

	1	2	4	8	16	32	64	128	256
385									
386									
387									
388									
389									
390									
391									
392									
393									
394									
395									
396									
397									
398									
399									
400									
401									
402									
403									
404									
405									
406									
407									
408									
409									
410									
411									
412									
413									
414									
415									
416									
417									
418									
419									
420									
421									
422									
423									
424									
425									
426									
427									

	1	2	4	8	16	32	64	128	256
428									
429									
430									
431									
432									
433									
434									
435									
436									
437									
438									
439									
440									
441									
442									
443									
444									
445									
446									
447									
448									
449									
450									
451									
452									
453									
454									
455									
456									
457									
458									
459									
460									
461									
462									
463									
464									
465									
466									
467									
468									
469									
470									

	1	2	4	8	16	32	64	128	256
471									
472									
473									
474									
475									
476									
477									
478									
479									
480									
481									
482									
483									
484									
485									
486									
487									
488									
489									
490									
491									
492									
493									
494									
495									
496									
497									
498									
499									
500									
501									
502									
503									
504									
505									
506									
507									
508									
509									
510									

Dark shaded boxes indicate ON; white boxes OFF.

18001024

*THIS PAGE INTENTIONALLY LEFT BLANK*

## WIND CONDITIONS

---



### WARNING

#### TIPPING CRANE HAZARD!

Judgment and experience of qualified operators, job planners, and supervisors must be used to compensate for affect of wind on lifted load and boom by reducing ratings, reducing operating speeds, or a combination of both.

Failing to observe this precaution can cause crane to tip or boom and/or jib to collapse. Death or serious injury to personnel can result.

---

Wind adversely affects lifting capacity and stability as shown in [Figure 3-52](#). The result could be loss of control over the load and crane, even if the load is within the crane's capacity.

Wind speed (to include wind gusts) must be monitored by job planners and supervisors.

*Beware that wind speed at boom point can be greater than wind speed at ground level. Also beware that the larger the sail area of the load, the greater the wind's affect on the load.*

As a general rule, ratings and operating speeds must be reduced when:

**Wind causes load to swing forward past allowable operating radius or sideways past either boom hinge pin.**

For wind conditions specific to this crane and its attachments, see the Wind Conditions publication at the end of this section or, if applicable, the Capacity Charts provided with this crane and its attachments.

18001024

Forward stability is affected by wind on the rear of the boom. Wind applies a force to the boom and load that adds to the crane's overturning moment. This action has the same effect as adding load to the hook.

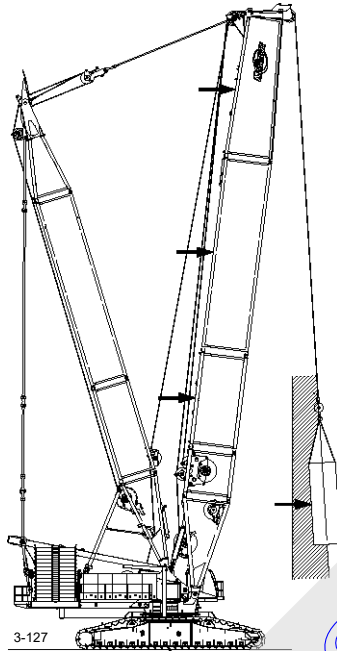

The wind's affect on the rear of the load increases load radius. This condition can result in an overload hazard, possibly causing the crane to tip or the boom to collapse.

To avoid this hazard, reduce operating speeds and load (see Wind Conditions Chart at the end of this section or see wind conditions in Capacity Charts if applicable).

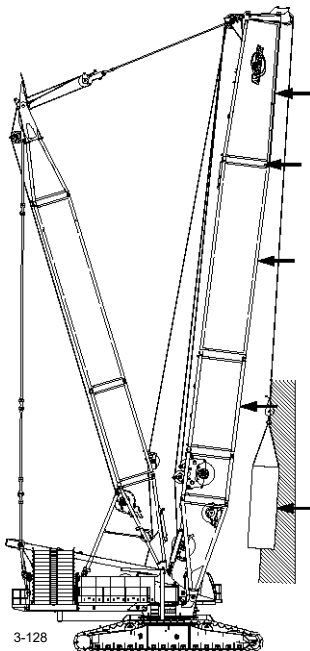

Backward stability is affected by wind on the front of the boom. This condition is especially dangerous when the boom is at or near the maximum angle when operating without load.

Wind forces on the front of the boom reduce the normal forward tipping effect of the boom. The crane can tip or the boom can collapse if this condition is not avoided.

The boom can buckle and collapse if the load contacts the boom.

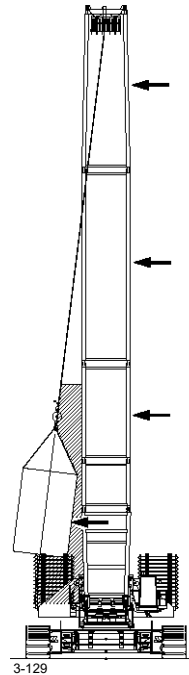

Boom strength is affected the most when the wind acts on the side of the boom.

The wind's affect on the side of the load can cause the load to swing out past the boom hinge pin. This condition can result in excessive side load forces on the boom, possibly causing the crane to tip or the boom to collapse.

To avoid this hazard, reduce operating speeds and load (see Wind Conditions Chart at the end of this section or see wind conditions in Capacity Charts if applicable).

FIGURE 3-52

A16692-1

Item	Description
1	Receptacle – 240 volt
2	Power Cord (Customer Supplied)
3	Circuit Breaker Load Center
3a	Main – 50 amp
3b	Engine Coolant and Oil Heaters – 20 amp
3c	Cab Console and Battery Pad Heaters – 15 amp
3d	Hydraulic Tank Heater – 15 amp
4	Right Front Control Console Heater – 240 volt, 125 watt
5	Battery Pad Heaters (2) – 240 volt, 75 watt
6	Engine Coolant Heater – 240 volt, 4,000 watt
7	Engine Oil Heater – 240 volt, 300 watt
8	Hydraulic Tank Heaters (1 Current, 5 Past) – 120 or 240 volt, 500 watt
9	Hydraulic Tank Heating Blanket

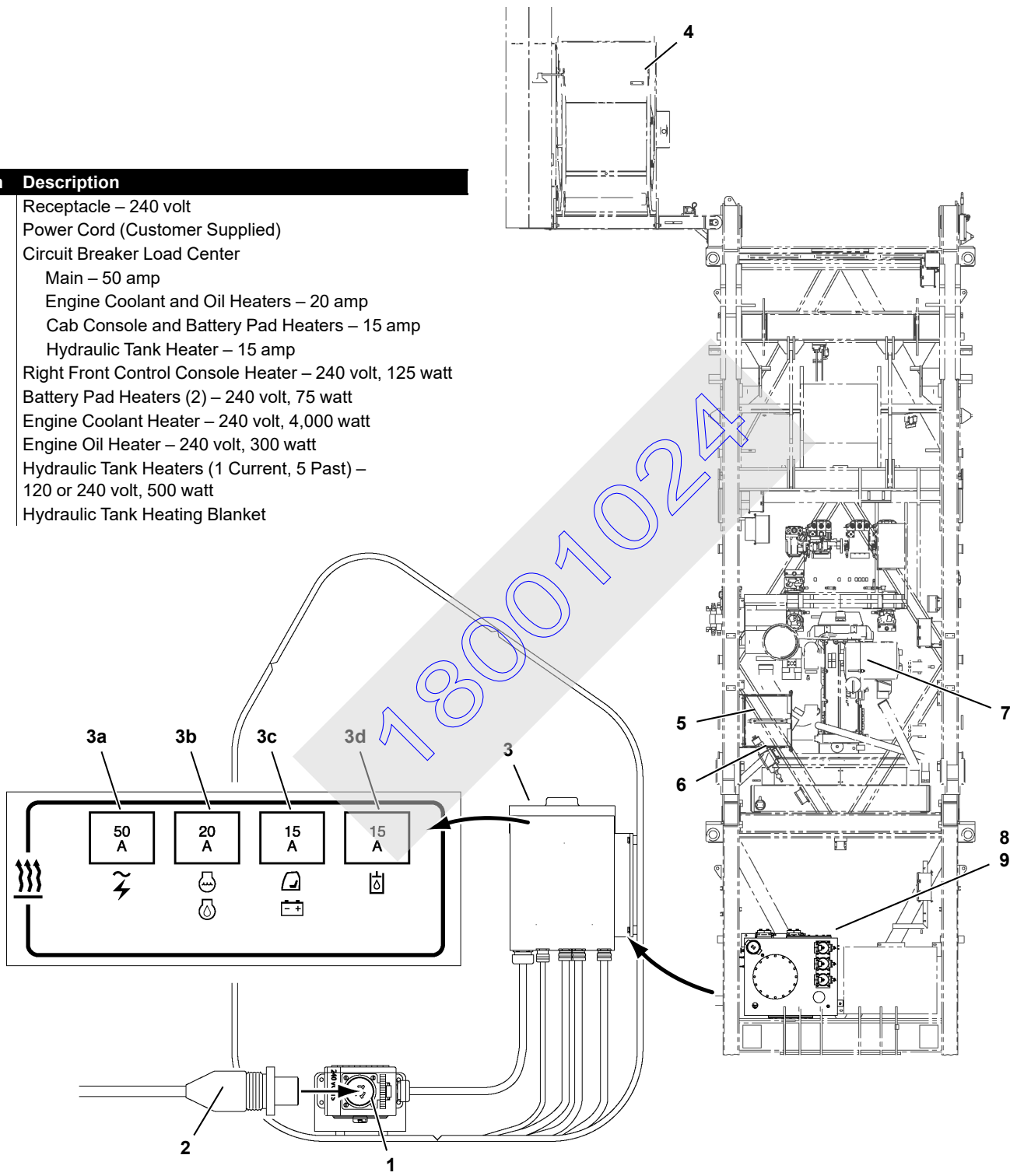

FIGURE 3-53



## COLD WEATHER HEATER PACKAGE

### General

The optional cold weather heater package preheats critical machinery and lubricant sumps during cold weather shutdown.

When operated in an arctic climate — outside temperature continuously below 0°F (-18°C) and -30°F (-34°C) — the crane should be equipped with the heaters identified below and lubricated with the lubricants listed in Section 5 of this manual.

---

### CAUTION

#### Machinery Damage!

Operating in an arctic climate without heaters can damage machinery during cold weather start-up due to lack of lubrication.

Heater package described in this section may not provide adequate protection when operating below -30°F (-34°C). Contact your Manitowoc dealer for recommendations.

Do not use heater package when operating above 40°F (4°C).

#### Hydraulic Pump Damage!

To prevent damage to pumps, warm hydraulic oil to 60°F (16°C) minimum before operating crane in an arctic climate.

### Heaters

The heaters operate on 120/240 volt AC single phase electrical power supplied by a external power supply. The heater package includes the following:

- 240 volt receptacle and circuit breaker load center
- Right front control console heater — with thermostat that turns heater ON at 50°F (10°C) and OFF at 60°F (16°C)
- Battery pad heaters — without thermostats

- Engine coolant heater with thermostat that turns heater ON at 100°F (38°C) and OFF at 120°F (49°C)
- Engine oil heater — without thermostat
- Hydraulic oil tank heater with thermostat set at 100°F (38°C)

### Turning Heaters On

1. External power supply must be disconnected. Then proceed as follows:
  - a. Check that main circuit breaker and each heater circuit breaker is off.
  - b. Check that external power source is off.



### WARNING

#### Electrocution Hazard!

Severe electric shock can cause death or serious injury. Crane owner/user shall make provisions for turning off electrical power supply before connecting power supply cord to crane.

- c. Connect power cord to receptacle at rear of operator's cab.
- d. Turn on external power supply.
- e. Turn on main circuit breaker.
- f. Turn on each heater circuit breaker.

### Turning Heaters Off

1. Turn off main circuit breaker.
2. Turn off each heater circuit breaker.
3. Perform the remaining steps only if power supply cord will be disconnected or electrical system is being serviced:
  - a. Turn off external power supply.
  - b. Unplug power cord from crane.

## PREPARATION FOR COLD WEATHER

### Crane Limitations

The static load carrying limitations of the steels used in Manitowoc cranes is not affected by cold weather. Therefore, Manitowoc's standard capacity charts are acceptable for use in cold weather.

Dynamic loads (impact and shock) can affect the steels used in Manitowoc cranes when operating in cold weather. Dynamic loads are created by traveling, sudden application and release of load, and duty-cycle operations (dragline, clamshell, magnet, container handling, concrete bucket placement).

To prevent possible damage to the crane and its attachment when operating during cold weather Manitowoc recommends:

#### **-5F° (-21°C) to -22F° (-30°C)**

Avoid impact or shock loading of crane and attachment. Operations involving hydraulic cranes should be conducted with due regard to potential failure of hydraulic components.

#### **-23F° (-31°C) to -40F° (-40°C)**

Derate crane by 40% for all lift operations. Halting all lifts should be considered. Duty-cycle operation is prohibited.

#### **Below -40F° (-40°C)**

All operation (lift and duty-cycle) is prohibited except in extreme emergencies, and then only with approval from a competent engineer who has derated the crane accordingly.

### Wire Rope

The wire rope manufacturers indicate that wire rope will not become brittle in temperatures down to -30°F (-34°C). Lubrication may be a problem, however. During extreme cold weather, normal wire rope lubricants may harden and chip off leaving the rope unlubricated.

Consult your wire rope supplier for recommended cold-weather lubricants.

### Cold Weather Starting Aid

Engine startup at temperatures below 40°F (4°C) requires the use of a cold weather starting aid.

#### **Ether**

Follow the engine manufacturer's recommendations and precautions for use of ether when starting the engine.



### **DANGER**

#### **Engine Explosion Hazard!**

Some engines are equipped with an air intake pre-heater. If engine on your crane has an air intake pre-heater, do not spray any combustible starting aid (ether) into air intake. Pre-heater will ignite ether resulting in a severe explosion and/or burns.

#### **Coolant and Oil Pan Heaters**

120 V coolant and oil pan heaters can be installed in the engine. The heaters utilize an electric heating element to heat the coolant and oil inside the engine when the crane is idle. Each heater is equipped with an extension cord for connection to an owner furnished electric power supply. The coolant heater must be capable of maintaining the engine's coolant and oil temperatures between 40°F to 50°F (4°C to 10°C). Contact the nearest engine dealer for availability and installation of the heaters.

***Engine heaters must be unplugged when engine is running to prevent cooling system from overheating.***

#### **Cooling System**

The cooling system must be kept full and be protected from freezing at the lowest expected ambient temperature. See the engine manual for antifreeze recommendations.

Be aware that a mixture of 40% antifreeze and 60% water will provide freeze protection to -35°F (-37°C). A mixture of 60% antifreeze and 40% water will provide freeze protection to approximately -60°F (-51°C). 100% antifreeze will freeze at -10°F (-23°C).

#### **Battery**

To provide maximum cranking power and to prevent the battery from freezing, it must be kept fully charged (1.26 to 1.28 specific gravity) and warm when the crane is idle during cold weather.

It is recommended that the battery be stored indoors or heated with a battery heater when the crane is idle.

Be aware that:

- A battery with a 50% charge freezes at -16°F (- 27°C); on the other hand, a battery with a 100% charge freezes at -70°F (-57°C).
- A battery with a 100% charge retains only 40% of its cranking power at 0°F (-18°C). At -20°F (-29°C), the same battery retains only 18% of its cranking power.

## Engine Oil

See the engine manual for recommendations.

## Fuel Oil

See the engine manual for recommendations.

## Gear Oil

### *Hydraulic Cranes*

Use a gear oil which meets MIL-L-2105C specification or API-GL-5 classification. Change to one of the below listed viscosities when the corresponding temperature range will be encountered.

- 75W-90 below -10°F (-23°C)
- 80W-90 above -10 to 100°F (-23 to 38°C)
- 85W-140 above 100°F (38°C)

## Hydraulic Oil

### *General*

Optional thermostatically controlled heaters (120V or 240V) can be installed in the hydraulic tank to aid in cold-weather

startup. The heaters are designed to keep the oil temperature 30°F (17°C) warmer than the ambient temperature.

***Either disconnect or turn off hydraulic tank heaters before starting engine to prevent hydraulic system from overheating.***

### *Hydraulic Cranes*

Change the oil in the hydraulic system to ISO Grade 15 when the expected ambient temperature will remain at 32°F (0°C) or below.

Change the oil in the hydraulic system to ISO Grade 46 when the expected ambient temperature will remain above 32°F (0°C).

## CIRCUIT BREAKERS

See Section 3 in the Service Manual for identification and location of the circuit breakers used to protect the crane's electric circuits.

18001024

*THIS PAGE INTENTIONALLY LEFT BLANK*

18001024

# SECTION 4

## SET-UP AND INSTALLATION

### TABLE OF CONTENTS

Rigging Drawings . . . . .	4-1
Optional Attachments . . . . .	4-1
General Safety . . . . .	4-1
Crane Orientation . . . . .	4-1
Self-Erecting Equipment . . . . .	4-1
Assist Crane Requirements . . . . .	4-2
Assembly and Disassembly Notes . . . . .	4-2
Assembly And Disassembly Area . . . . .	4-2
Accessing Parts . . . . .	4-2
Crane Weights . . . . .	4-2
Handling Components . . . . .	4-2
Retaining Connecting Pins . . . . .	4-5
Cold Weather Mast Operation . . . . .	4-5
Shipping Crane Components . . . . .	4-8
Operating Controls . . . . .	4-8
Pre-Start Checks . . . . .	4-9
Engine . . . . .	4-9
Gear Boxes . . . . .	4-9
Hydraulic System . . . . .	4-9
Crane Assembly . . . . .	4-9
Rotating Bed Jack Pad Storage Location . . . . .	4-9
Remove Rotating Bed from Trailer . . . . .	4-10
Remove Wind Deflectors . . . . .	4-10
Deploy Rotating Bed Jacks . . . . .	4-12
Alignment Pendants . . . . .	4-14
Deploy Operator's Cab . . . . .	4-14
Jack Upperworks Off Trailer . . . . .	4-14
Remove Carbody and Adapter Frame from Trailer . . . . .	4-16
Connect Rotating Bed to Carbody . . . . .	4-16
Lower Crane onto Carbody Pedestals . . . . .	4-18
Install Rotating Bed Catwalks and Steps (Past Production) . . . . .	4-20
Side and Rear Catwalks . . . . .	4-20
Steps . . . . .	4-20
Cab Rear Catwalk . . . . .	4-20
Install Rotating Bed Side and Rear Catwalks and Steps (Current Production) . . . . .	4-22
Side and Rear Catwalks . . . . .	4-22
Steps . . . . .	4-22
Connect Hydraulic Hoses and Electric Cables . . . . .	4-22
Install Drum 3 (Whip Line Drum) . . . . .	4-22
Install Cab Left Platform (Current Production) . . . . .	4-24
Install Cab Rear Platform (Current Production) . . . . .	4-26
Move Platforms into Working Positions (Current Production) . . . . .	4-26
Configure Enclosure Panels . . . . .	4-29
Working Position . . . . .	4-29
Raise Live Mast To Operating Position . . . . .	4-31
Install Assembly Block . . . . .	4-33
Install Crawlers . . . . .	4-33
Install First Crawler . . . . .	4-35
Install First Crawler (continued) . . . . .	4-37
Install Second Crawler . . . . .	4-37
Install Counterweight . . . . .	4-39



Install Carbody Counterweight . . . . .	4-39
Install Crane Counterweight . . . . .	4-39
Stow Mast Supports . . . . .	4-41
Deploy Mast Supports . . . . .	4-41
Remove Assembly Block . . . . .	4-43
Assemble Fixed Mast . . . . .	4-43
Install Mast Butt and Top . . . . .	4-43
Assemble Mast Inserts . . . . .	4-45
Connect Mast Inserts to Mast Butt . . . . .	4-47
Raise Mast Stops . . . . .	4-47
Lower Wire Rope Guide . . . . .	4-47
Attach Mast Top to Inserts . . . . .	4-49
Connect Mast Straps . . . . .	4-49
Connect Live Mast Straps to Fixed Mast Straps . . . . .	4-49
Perform Mast Pre-Raising Checks . . . . .	4-51
Raise Fixed Mast . . . . .	4-51
General . . . . .	4-51
Raise Mast . . . . .	4-53
Check Mast Stop Pressure . . . . .	4-55
Assemble and Install Boom and Jib . . . . .	4-55
Pre-Raising Checks . . . . .	4-56
Raising Boom and Jib . . . . .	4-57
Crane Disassembly . . . . .	4-59
Lowering Boom And Jib . . . . .	4-59
Lower Fixed Mast . . . . .	4-59
General . . . . .	4-59
Disconnect Live Mast Straps . . . . .	4-63
Store Wire Rope Guide . . . . .	4-63
Store Mast Stops . . . . .	4-63
Remove Mast Inserts . . . . .	4-63
Remove Mast Butt and Top . . . . .	4-65
Remove Rear Platforms and Catwalk (Past Production) . . . . .	4-65
Remove Rear Platforms and Catwalk (Current Production) . . . . .	4-65
Remove Crane Counterweight . . . . .	4-65
Install Assembly Block . . . . .	4-65
Remove Carbody Counterweight . . . . .	4-67
Deploy Rear Rotating Bed Jacks . . . . .	4-67
Remove Crawlers . . . . .	4-69
Remove First Crawler . . . . .	4-69
Remove Second Crawler . . . . .	4-73
Remove Assembly Block . . . . .	4-73
Store Live Mast . . . . .	4-73
Remove Drum 3 (Whip Line Drum) . . . . .	4-73
Deploy Front Rotating Bed Jacks . . . . .	4-73
Separate Rotating Bed From Carbody . . . . .	4-74
Place Rotating Bed on Trailer . . . . .	4-74
Store Operator's Cab . . . . .	4-74
Remove Rotating Bed Jacks . . . . .	4-74
Install Wind Deflectors . . . . .	4-74
Boom Ladder Assembly . . . . .	4-76
General . . . . .	4-76
Removing Ladders from Boom Section . . . . .	4-76
Installing Ladders on Boom Inserts . . . . .	4-76
Storing Ladders . . . . .	4-76
Boom and Jib Rigging . . . . .	4-80
Assist Crane Requirements . . . . .	4-80
Blocked Crawler . . . . .	4-80

Handling Components . . . . .	4-80
Rigging Assembly Drawings . . . . .	4-80
Medium Inserts . . . . .	4-80
Identifying Boom and Jib Sections and Straps . . . . .	4-81
Boom Installation . . . . .	4-83
Inspect Boom Stops . . . . .	4-83
Assemble Boom Butt and First Insert . . . . .	4-85
Raise Drum 1 to Operating Position . . . . .	4-85
Install Second Insert . . . . .	4-85
Raise Drum 6 Sheaves . . . . .	4-85
Install Boom Butt and Assembled Inserts . . . . .	4-87
Assemble Remaining Boom Sections . . . . .	4-89
Raise Boom Top Wire Rope Guide . . . . .	4-89
Connect Boom Straps — #55-79A Boom . . . . .	4-91
Install Intermediate Suspension — #55-79A Boom . . . . .	4-91
Connect Boom Straps — #55 or #55A Boom . . . . .	4-93
Install Intermediate Suspension — #55 OR #55A Boom . . . . .	4-93
Install Standard Upper Boom Point . . . . .	4-95
Install Extended Upper Boom Point . . . . .	4-95
Install Rated Capacity Indicator/Limiter . . . . .	4-97
Install Load Line . . . . .	4-97
Install Block-Up Limit Control . . . . .	4-97
Install Block-Level Transmitter . . . . .	4-98
Connect Electric Cables . . . . .	4-98
Install Wind Speed Indicator Assembly . . . . .	4-99
Boom Pre-Raising Checks . . . . .	4-99
Boom Removal . . . . .	4-102
Fixed Jib Installation . . . . .	4-105
General . . . . .	4-105
Prepare Crane, Boom, and Mast . . . . .	4-105
Install Boom Backstay Straps . . . . .	4-105
Assemble Jib . . . . .	4-107
Install Jib Butt . . . . .	4-107
Install Jib Strap Support Brackets . . . . .	4-107
Install Jib Inserts and Top . . . . .	4-107
Install Upper Jib Point . . . . .	4-107
Connect Remaining Jib Straps . . . . .	4-107
Connect Jib Straps to Equalizers . . . . .	4-107
Attach Jib Stop to Boom Top . . . . .	4-109
Install Jib Strut . . . . .	4-109
Connect Adjustable Links . . . . .	4-109
Raise Jib Strut . . . . .	4-111
Raise Jib Strut (continued) . . . . .	4-113
Install Jib Load Line . . . . .	4-113
Connect Electric Cords . . . . .	4-113
Install Wind Speed Indicator Assembly . . . . .	4-113
Jib Removal . . . . .	4-114
Disconnect Electric Cords . . . . .	4-114
Remove Wind Speed Indicator Assembly . . . . .	4-114
Remove Jib Load Lines . . . . .	4-114
Lower Jib Strut . . . . .	4-114
Disconnect Jib Straps . . . . .	4-115
Remove Jib Inserts and Top . . . . .	4-115
Store Jib Strap Support Brackets . . . . .	4-115
Remove Jib Butt . . . . .	4-115
Wire Rope Installation . . . . .	4-117
Wire Rope Storage . . . . .	4-117

18001024



Removing Wire Rope from Shipping Reel . . . . .	4-117
Seizing and Cutting Wire Rope . . . . .	4-117
Anchoring Wire Rope to Drum . . . . .	4-118
Winding Wire Rope onto Drum . . . . .	4-118
Anchoring Wire Rope to Socket And Wedge . . . . .	4-119
Anchoring Wire Rope to Button Socket . . . . .	4-121
Breaking in Wire Rope . . . . .	4-121
Pad Eye Usage for Wire Rope Reeving . . . . .	4-121
General . . . . .	4-121
Safety . . . . .	4-121
Rigging Winch Operation . . . . .	4-123
Selecting Rigging Winch Mode . . . . .	4-123
Operating Rigging Winch (Past Production) . . . . .	4-123
Operating Rigging Winch (Current Production) . . . . .	4-124
Load Block Reeving . . . . .	4-126
Load Block Identification . . . . .	4-126
Load Block Handling . . . . .	4-126
Wire Rope Specifications . . . . .	4-126
Wire Rope Installation and Maintenance . . . . .	4-126
Duplex Hook . . . . .	4-126
Guide Sheaves and Drums . . . . .	4-126
Load Block Reeving . . . . .	4-126
Block Level Sensor Adjustment . . . . .	4-136
General . . . . .	4-136
Sensor Adjustment . . . . .	4-136
Live Mast Reeving . . . . .	4-137
General . . . . .	4-137
Wire Rope Specification . . . . .	4-137

18001024

## SECTION 4

### SET-UP AND INSTALLATION

#### RIGGING DRAWINGS

For boom and jib rigging drawings that apply to your crane, see the end of this section.

#### OPTIONAL ATTACHMENTS

If applicable, instructions for optional attachments that apply to your crane are located at the end of this section.

#### GENERAL SAFETY

To prevent accidents that can result in death or injury during crane assembly and disassembly, comply with the following general safety information and with specific safety information contained in assembly and disassembly steps.



#### WARNING

##### Avoid Death or Serious injury!

Read and understand setup and installation instructions in this section before attempting to assemble or disassemble crane.



#### WARNING

##### Tipping/Overload Hazard!

Avoid tipping crane over or collapsing live mast.

- Assemble and disassemble crane on a firm, level, uniformly supporting surface.
- Do not exceed swing limits and mast lifting capacities given in [Table 4-2](#).
- Do not allow crane to go more than 3° out of level when operating rotating bed jacks.



#### WARNING

##### Avoid Falling Off Crane and Boom!

It is necessary to climb onto crane and boom during assembly and disassembly steps.

Use sturdy owner furnished ladders or an approved personnel hoist to gain access to areas which cannot be reached from ladders or steps provided with crane.



#### WARNING

##### Moving Parts/Pinch Points!

Avoid death or crushing injury during crane assembly and disassembly:

- Assembly personnel — take every precaution to prevent injury when working near moving parts.
- Maintain communication between operator and assemblers to avoid accidents.
- Do not raise or lower either mast (live or fixed) until all personnel are off crane.

Keep unauthorized personnel well clear of crane.



#### WARNING

##### Falling Load Hazard!

To prevent lifting equipment from failing and load from dropping, crane owner/user shall verify the following prior to each lift:

- All lifting equipment (shackles, hooks, slings, blocks) has been properly maintained and is safe for use.
- All lifting equipment has a capacity equal to or greater than load to be lifted.

#### CRANE ORIENTATION

The terms RIGHT, LEFT, FRONT, REAR used in this section refer to the operator's right, left, front, and rear sides when seated in the operator's cab looking forward with the crawler motors to the rear.

#### SELF-ERECTING EQUIPMENT

The 18000 is equipped with the following self-erect components for assembly and disassembly:

1. Rotating bed jacks with pads for lifting the crane onto and off the trailer
2. Carbody pedestals for supporting the carbody (with rotating bed) during crawler assembly
3. Hydraulically actuated arms for raising and lowering the live mast from and to the transport position
4. Live mast which serves as a boom to install the crane's crawlers and carbody counterweights and to handle other components as required
5. 100 USt (91 t) load block and 4-leg sling with hooks for handling parts. The block weighs 1,500 lb (680 kg).

## ASSIST CRANE REQUIREMENTS

An assist crane is required for handling and installing the following components:

- Rotating bed jacks
- Drum 3 (whip line)
- Crane (upperworks) counterweight trays and boxes
- Catwalks and steps
- Fixed mast
- Boom inserts

The assist crane must be capable of lifting 60,000 lb (27 216 kg) to a height of 30 ft (9,1 m). This is the weight of the mast butt and top in the shipping configuration.

See Crane Weights in Section 1 of this manual for weights of components

## ASSEMBLY AND DISASSEMBLY NOTES

The crane, boom, and jib must be assembled and disassembled by experienced personnel trained in erection and operation of construction cranes.

Read and become thoroughly familiar with the instructions in the applicable capacity charts, in this section, and in the rigging drawings at the rear of this section before attempting to assemble, operate, or disassemble the crane.

*Contact your Manitowoc dealer for assistance if any procedure is not fully understood.*

## ASSEMBLY AND DISASSEMBLY AREA

Select an assembly/disassembly area that has a firm, level, uniformly supporting surface. Make sure the area is large enough to accommodate the crane and the selected boom length, movement of trucks with trailers, and movement of an assist crane.

Set jack pads and carbody pedestals on a flat, firm foundation that will support the load placed on them. See [Table 4-1](#) for loadings.

Do not set the jack pads or carbody pedestals in holes, on rocky ground, or on extremely soft ground.

If necessary, use wood blocking or steel plates under the jack pads and carbody pedestals to properly distribute loading. The wood blocking or steel plates must be:

- Free of defects
- Strong enough to prevent being crushed or bent
- Of sufficient length and width to prevent settling under load

*Contact Technical Services Department at factory for ground bearing information.*

**Table 4-1 Jack and Pedestal Load Data**

Maximum load on each jack — 140,000 lb (63 500 kg)
Jack pad size — 30.5 in (775 mm) diameter
Jack pad weight — 82 lb (37 kg)
Maximum load on each carbody pedestal — 220,000 lb (99 790 kg)
Carbody pedestal size — 30 x 48 in (762 x 1 219 mm)
Carbody pedestal assembly weight — 470 lb (214 kg)

## ACCESSING PARTS

Some parts of the crane, boom, and jib cannot be reached from the ground. Take necessary precautions to prevent falling off the crane or boom during assembly and disassembly. Falling from any elevation could result in serious injury or death.

Owner/user shall provide approved ladders or personnel hoists so workers can safely access those areas of crane, boom, and jib that cannot be reached from ground. Adhere to local, state, and federal regulations for handling personnel.

Do not use top of boom or jib as walkways.

Optional boom ladders are available from Manitowoc. If your crane has ladders, see the instructions later in this section.

## CRANE WEIGHTS

See Crane Weights in Section 1 for overall weight of the crane and individual weights of components.

## HANDLING COMPONENTS

The major components are equipped with lifting lugs which are identified in the assembly and disassembly steps.

When lifting lugs are not provided, use nylon lifting slings. If wire rope or chain slings are used, install protective covering (such as sections of rubber tire) between slings and component being lifted.

## CAUTION

### Lacing Damage!

- Ensure straps for boom inserts and top remain pinned and secured in the shipping position during handling and transportation unloading [Figure 4-1](#).

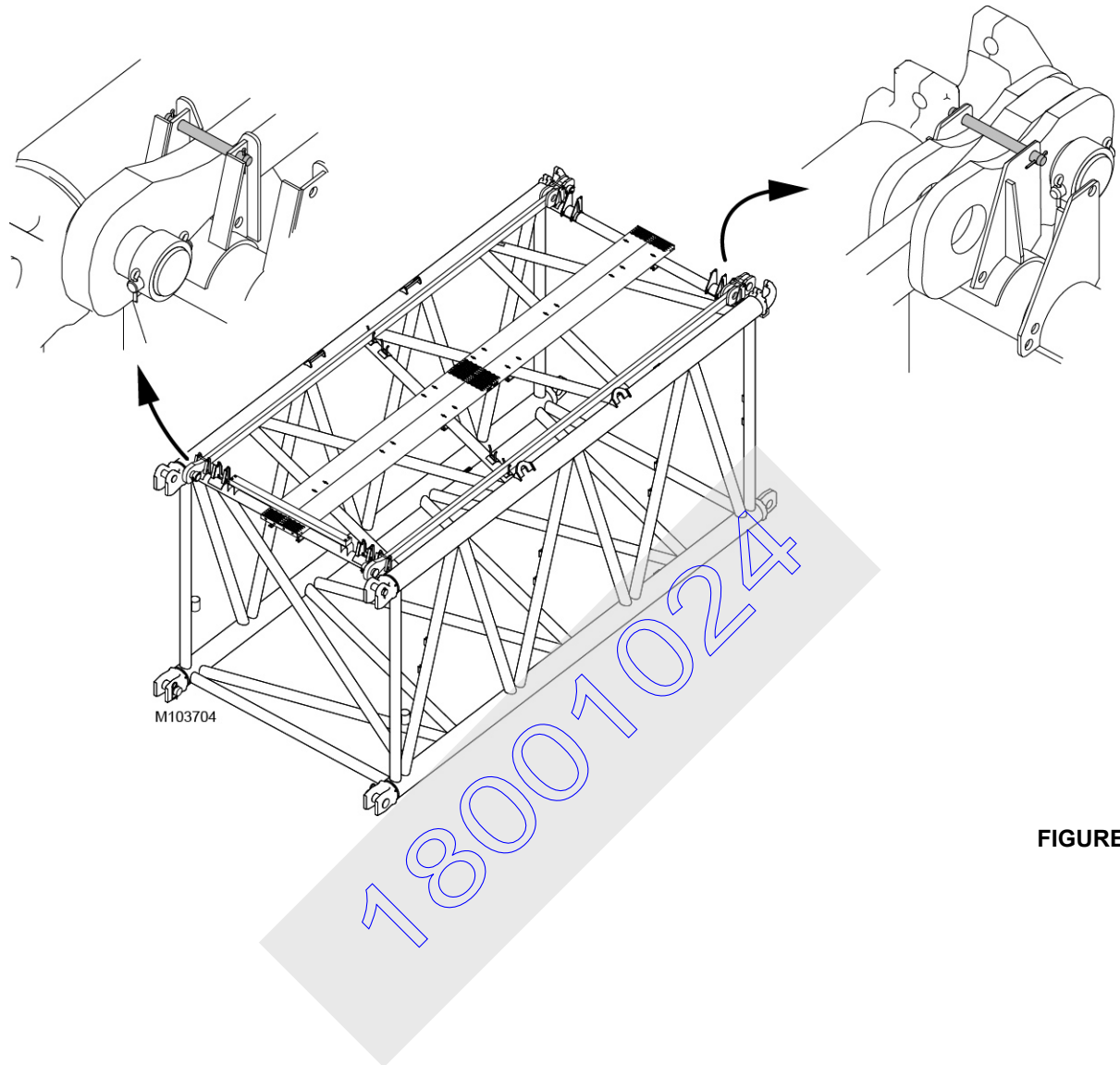
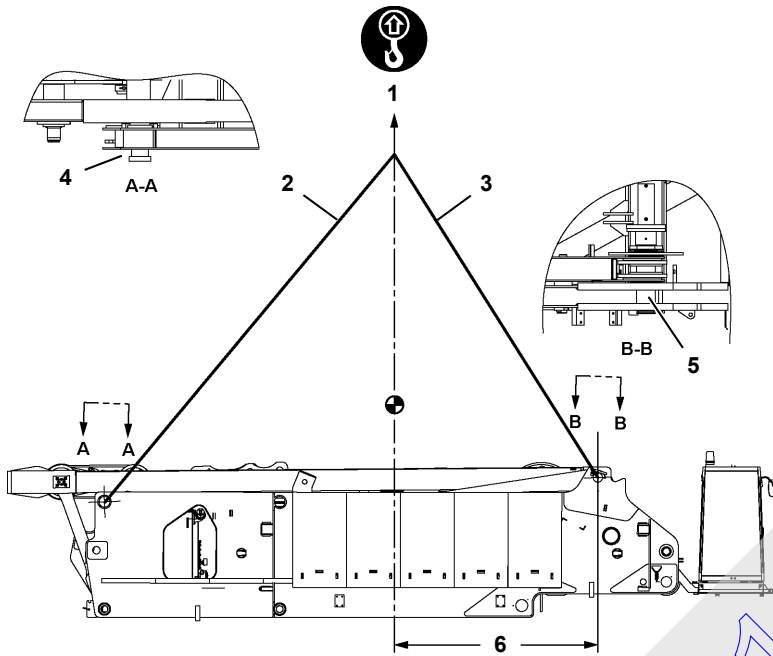

FIGURE 4-1

Refer to the following for lifting information:

- Upperworks Lifting Data (Figure 4-2)

- Carbody and Adapter Frame Lifting Data (Figure 4-3)
- Crawler Lifting Data Decal (Figure 4-23)



**WARNING**  
Crush Hazard!

- Use proper size rigging to lift as shown.

Item	Description
1	96,950 lb (43 976 kg)
2	25 ft 0 in – 24,950 lb (7,62 m – 11 317 kg)
3	24 ft 5 in – 31,250 lb (6,53 m – 14 175 kg)
4	Counterweight Lug (2)
5	Boom Hinge Pin (2)
6	11 ft 7 in (3,53 m)

FIGURE 4-2

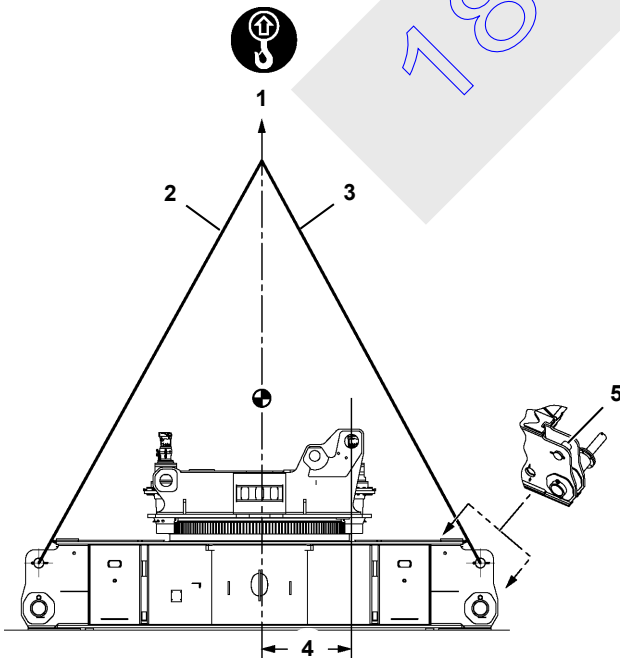

**WARNING**  
Crush Hazard!

- Use proper size rigging to lift as shown.

Item	Description
1	95,900 lb (43 500 kg)
2	25 ft 0 in – 27,850 lb (7,62 m – 12 633 kg)
3	24 ft 11 in – 27,150 lb (7,59 m – 12 315 kg)
4	4 ft 10-1/2 in (1,49 m)
5	Crawler Pin (4)

FIGURE 4-3

It is owner's/user's responsibility to ensure that all lifting slings, hooks, and shackles are in safe working order and capable of handling loads applied to them.

### RETAINING CONNECTING PINS

Connecting pins are retained in various ways:

- Snap pins
- Quick-release pins
- Cotter pins
- Keeper plates with cap screws and lock washers

*Do not operate crane until all connecting pins are installed and properly retained.*

### COLD WEATHER MAST OPERATION

The live mast, live mast cylinders, and live mast arms can be damaged when attempting to lower the live mast (to rear) during cold weather.

Do not attempt to lower the live mast with the mast hoist during cold weather until the following steps have been performed:

- Temperature of hydraulic oil warmed up to at least 60°F (16°C)
- Mast cylinders fully extended and retracted twice to fill cylinders with warm oil

18001024

4-100

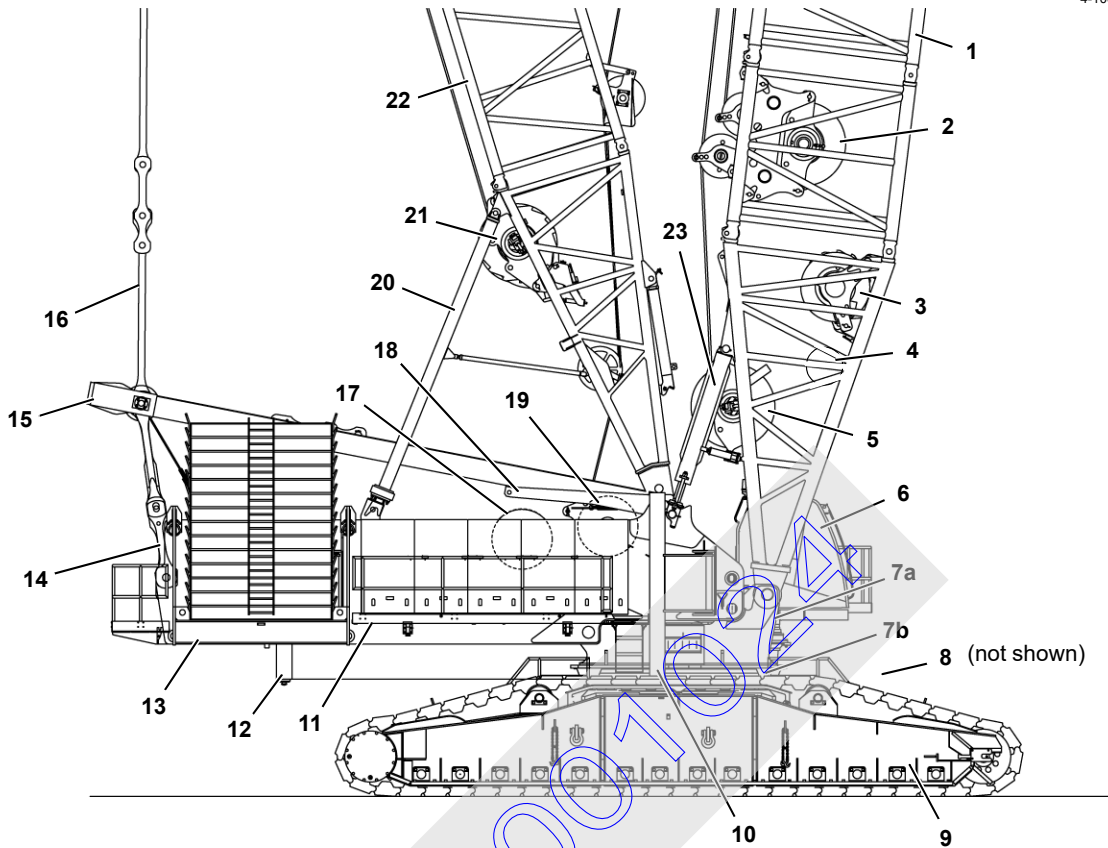

Item	Description	Item	Description
1	Boom	12	Rotating Bed Jack (2 at Rear)
2	Drum 1 (Main Hoist)	13	Crane (Upperworks) Counterweight
3	Drum 6 (Luffing Hoist)	14	Live Mast Straps
4	Drum 7 (Rigging Winch)	15	Live Mast
5	Drum 2 (Main Hoist)	16	Fixed Mast Straps
6	Operator's Cab	17	Drum 5 (Live Mast Hoist)
7a	Rotating Bed Adapter Frame	18	Live Mast Assist Arm (1 each side)
7b	Carbody	19	Drum 3 (Whip Hoist)
8	Carbody Counterweight (Front and Rear)	20	Mast Stop (both sides)
9	Crawler Assembly	21	Drum 4 (Boom Hoist)
10	Rotating Bed Jack (2 at Front)	22	Fixed Mast
11	Rotating Bed	23	Boom Stop

FIGURE 4-4



**Table 4-2  
Operating Limitations**

Crane Configuration	Swing	Max Capacity	Max Radius
<ul style="list-style-type: none"> <li>Crane on pedestals (rotating bed, adapter frame and carbody).</li> <li>Live mast raised or lowered (NOTE 1).</li> <li>No assembly block.</li> <li>No crawlers.</li> <li>No counterweight.</li> </ul>	NO!		
<ul style="list-style-type: none"> <li>Crane on pedestals (rotating bed, adapter frame and carbody).</li> <li>Live mast in operating range. (114° - 160°)</li> <li>Assembly block installed (NOTE 2).</li> <li>No crawlers installed (handling 1st crawler).</li> <li>No counterweight.</li> </ul>	5°	120,000 lb (54 431 kg)	26 ft (7,9 m)
<ul style="list-style-type: none"> <li>Crane on pedestals (NOTE 3).</li> <li>First crawler installed and resting on ground.</li> <li>No counterweight.</li> </ul>	180°		
<ul style="list-style-type: none"> <li>Crane on crawlers.</li> <li>Counterweight installed or removed.</li> <li>Handling loads with live mast.</li> </ul>	360°		

NOTE 1 Maximum mast angle = 160°.

NOTE 2 Chain sling and 5-part line required.

NOTE 3 Pedestals installed only on side of carbody opposite 1st crawler.

Crane Configuration	Swing (360°)	Travel
<b>CRAWLERS INSTALLED AND MAST REMOVED (NOTE 4)</b>		
<ul style="list-style-type: none"> <li>No carbody counterweight installed.</li> </ul>	Yes	Yes
<ul style="list-style-type: none"> <li>Upper counterweight trays installed (no boxes installed).</li> </ul>	Yes	Yes
<ul style="list-style-type: none"> <li>No carbody counterweight installed.</li> </ul>	NO!	NO!
<ul style="list-style-type: none"> <li>Upper counterweight installed (trays and boxes).</li> </ul>	NO!	NO!
<ul style="list-style-type: none"> <li>Carbody counterweight installed.</li> </ul>	Yes	NO!
<ul style="list-style-type: none"> <li>Upper counterweight installed (trays and boxes).</li> </ul>	Yes	NO!
<b>CRAWLERS INSTALLED AND MAST INSTALLED (NOTE 4)</b>		
<ul style="list-style-type: none"> <li>No carbody counterweight installed.</li> </ul>	Yes	Yes
<ul style="list-style-type: none"> <li>Upper counterweight trays installed (no boxes installed).</li> </ul>	Yes	Yes
<ul style="list-style-type: none"> <li>No carbody counterweight installed.</li> </ul>	NO!	NO!
<ul style="list-style-type: none"> <li>Upper counterweight installed (trays and boxes).</li> </ul>	NO!	NO!
<ul style="list-style-type: none"> <li>Carbody counterweight installed.</li> </ul>	Yes	NO!
<ul style="list-style-type: none"> <li>Upper counterweight installed (trays and boxes).</li> </ul>	Yes	NO!

NOTE 4 Applies to 100 ft (30.5 m) and 140 ft (42.7 m) mast.

**Contact Manitowoc Product Support for swing and travel specifications not listed.**

## SHIPPING CRANE COMPONENTS

It is the owner/user's responsibility to ensure the following:

- All trailer loads comply with local, state, and federal transportation requirements.
- **All crane components are properly blocked and secured so they cannot shift or fall off trailers.**
- To avoid damage to components:

Use nylon tie-downs to secure components as shown in [Figure 4-5](#), View A.

If chain tie-downs are used, install protective covering (sections of rubber tire) between chain and component being secured as shown in [Figure 4-5](#), View B.

When securing boom sections, wrap tie-downs over chords — never over lacings. Keep tie-downs as close to blocking as possible (View A) to prevent bending of chords.

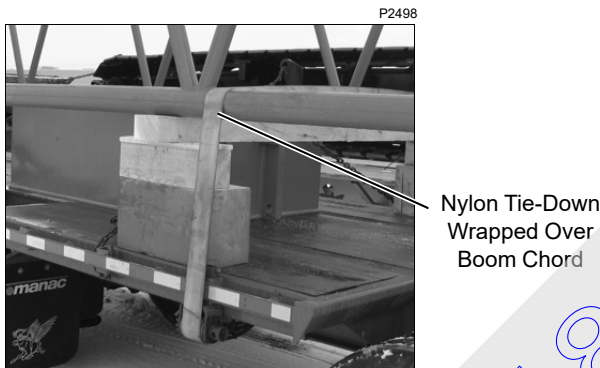

View A

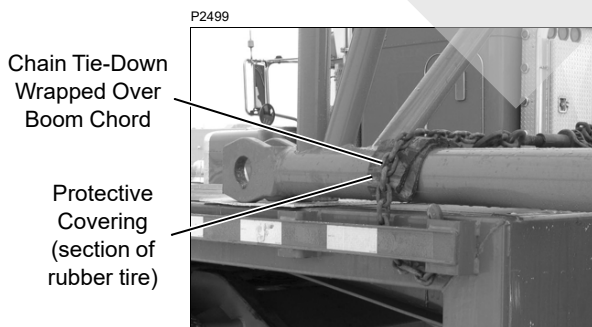

View B

FIGURE 4-5

## OPERATING CONTROLS

To assemble and disassemble the 18000 with the self-erecting system, the engine must be running and the crane SETUP REMOTE mode must be selected and confirmed. See Section 3 of this manual for remote control operating instructions.

**NOTE** The engine will not start until terminating plug (2, [Figure 4-18](#) on [page 4-27](#), View A) is connected to cable (1).

The rotating bed jacks, front and rear rotating frame pins, boom and mast hinge pins, mast assist cylinders, and rigging winch, are controlled by switches on a hand-held radio remote control ([Figure 4-6](#)). The remote control also selects engine speed.

**NOTE** Prior to using the ALL jacking cylinder switches, the accuracy of the rotating bed's level sender should be verified. The indication of the Tilt Right and Tilt Front can be found on the Digital Display.

**NOTE** When the ALL jacking cylinders switch is used, all of the rotating bed jacks will extend or retract at the same time (depending on which way switch is moved). The crane's programmable controller will automatically adjust the jacks to maintain or return the machine to level as sensed by the rotating bed's level sender.

The 'CRANE LEVEL' operating limit and the swing/travel alarm will sound if the rotating bed gets 3° out of level while jacking. The operator shall stop jacking and readjust the jacks to level the rotating bed.

If the rotating bed level senders indicate that the bed is greater than 4.7 degrees out of level, the 'CRANE LEVEL SENDER' system fault will be active in the cab, and the ALL jacks Switch is disabled. The accuracy of the angle indicators should be checked, and the machine leveled using the individual jacking switches.

### **WARNING** Tipping Hazard!

Do not allow rotating bed to go more than 3° out of level while jacking.  
Jacks could buckle allowing rotating bed to tip over.



Remote Control Stored in Rear of Operator's Cab

FIGURE 4-6

**PRE-START CHECKS**

Make the following checks before starting the engine upon arrival at the assembly site. See Section 3 for starting instructions.

**Engine**

1. Check for leaks.
2. Check fuel, oil, and coolant levels.

3. Repair or refill as required.

**Gear Boxes**

1. Check for leaks.
2. Check levels.
3. Repair or refill as required.

**Hydraulic System**

1. Check for leaks.
2. Check level.
3. Repair or refill as required.
4. Make sure hydraulic shut-off valve is open.

**CRANE ASSEMBLY**

**Rotating Bed Jack Pad Storage Location**

On current production cranes, rotating bed jack pads (1, Figure 4-7) are stored at the following locations:

1. On carbody counterweight trays (3, View A) during crane shipment
2. On carbody (4, View B) during crane operation

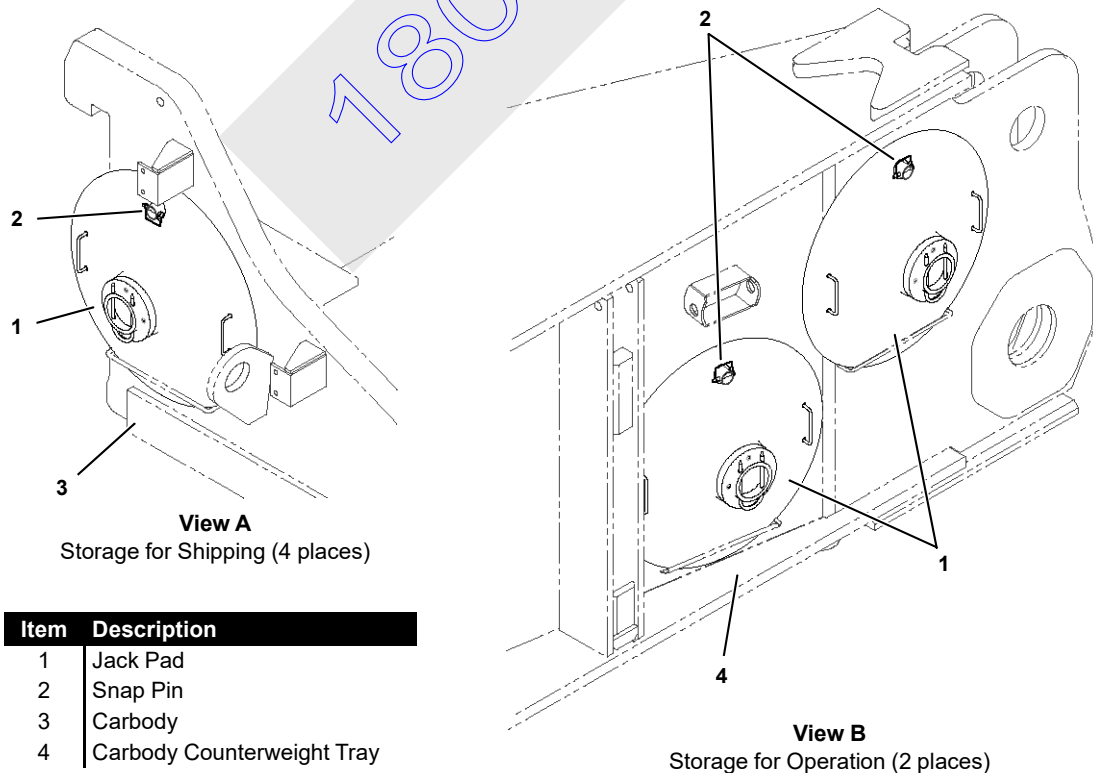

FIGURE 4-7

### Remove Rotating Bed from Trailer

#### Remove Wind Deflectors

**NOTE** Wind deflectors are not provided on current production cranes.

See [Figure 4-8](#) for the following procedure.

If equipped with wind deflectors, they will interfere with installation of the jacks and other components. Remove the wind deflectors while the rotating bed is on the trailer.

1. Remove all nuts with studs (1) on rotating bed (2).
2. Remove wind deflector (3, View B).
3. Attach deflector to studs on counterweight tray (4, View C) and secure with nuts (2 places).
4. Store remaining nuts on rotating bed studs.
5. Repeat preceding steps for deflector on other side.

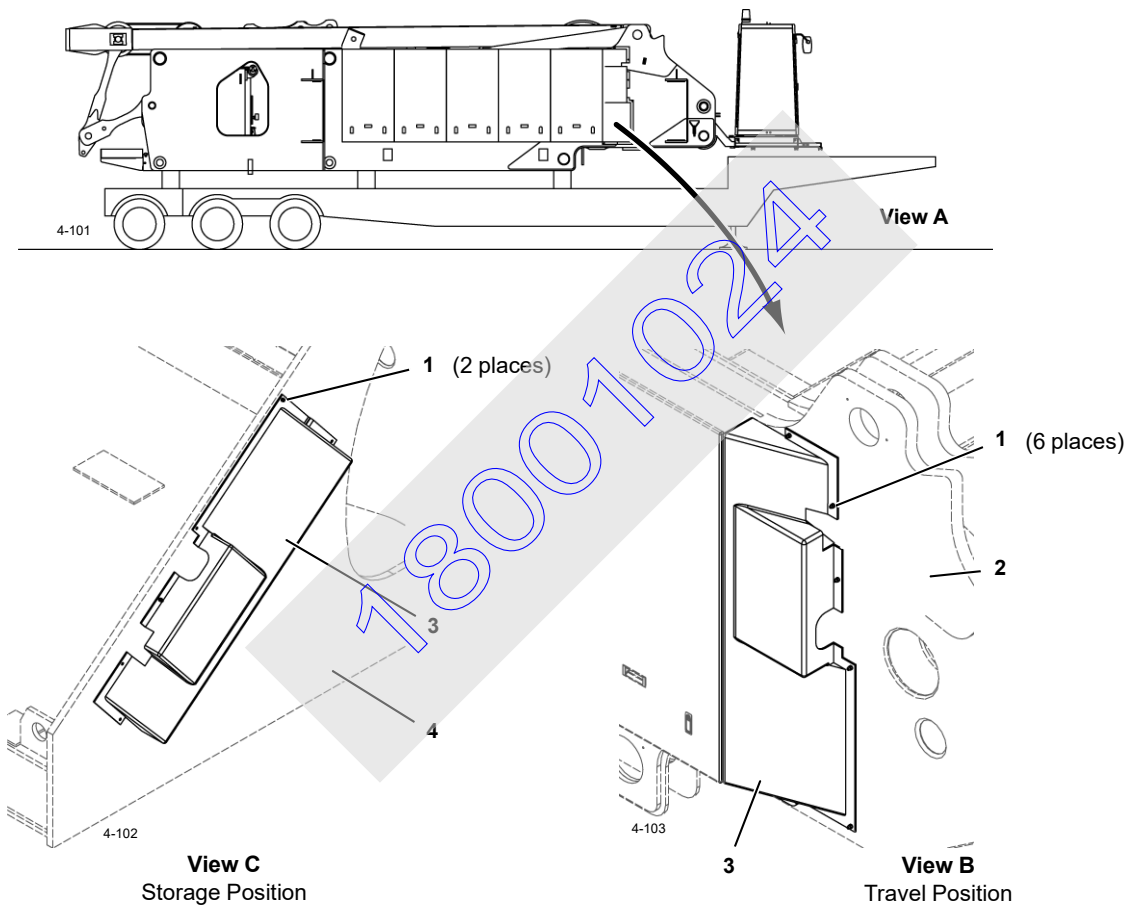

Item	Description
1	Stud with Nut
2	Rotating Bed
3	Wind Deflector
4	Counterweight Tray

FIGURE 4-8

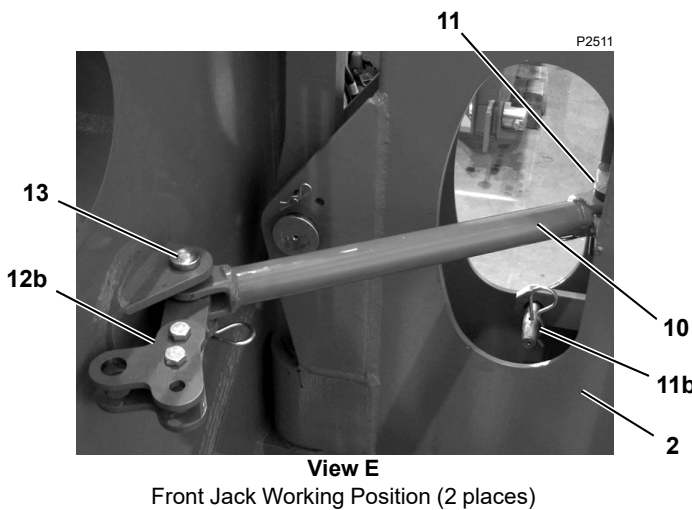
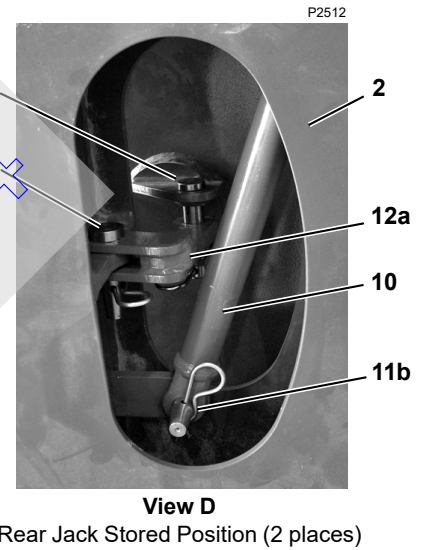
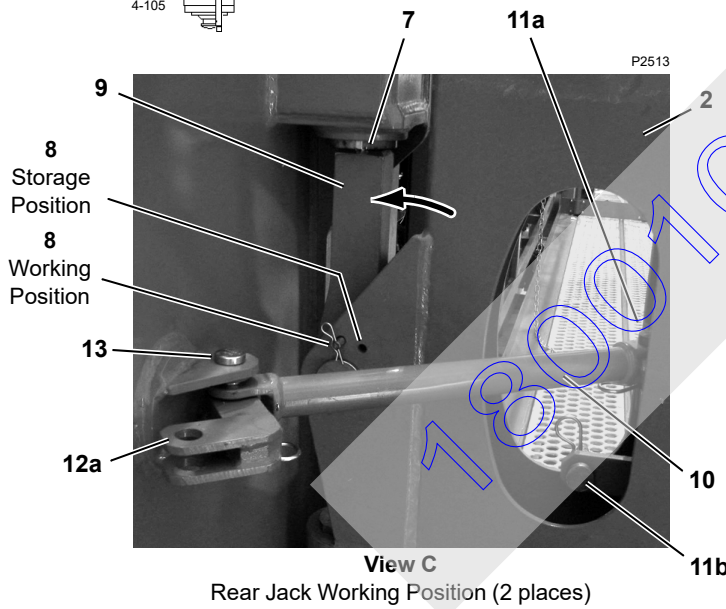
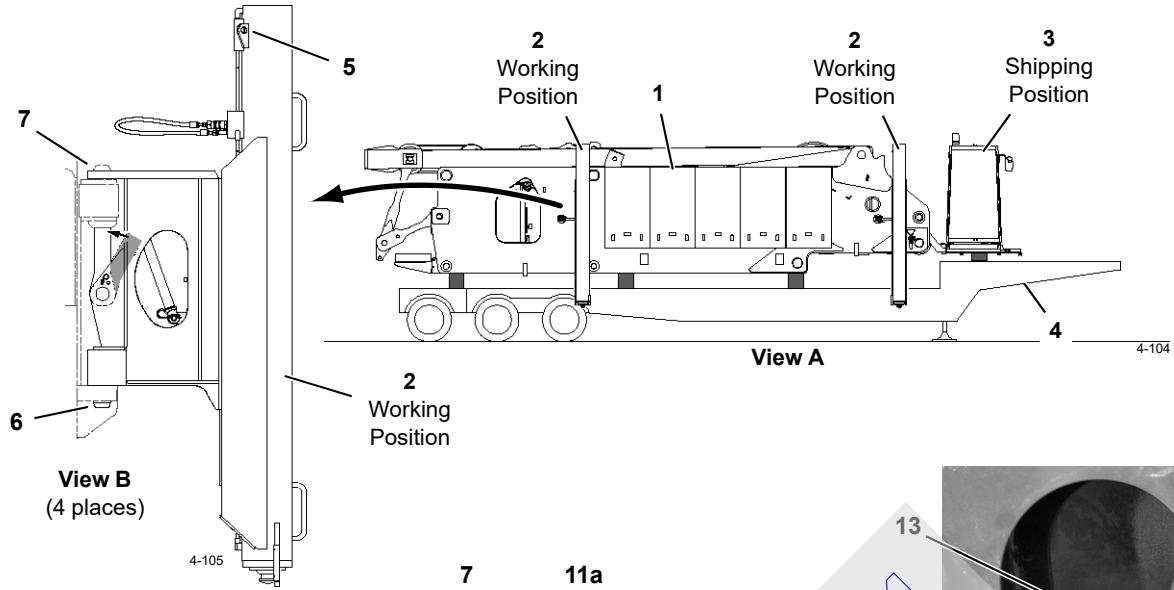
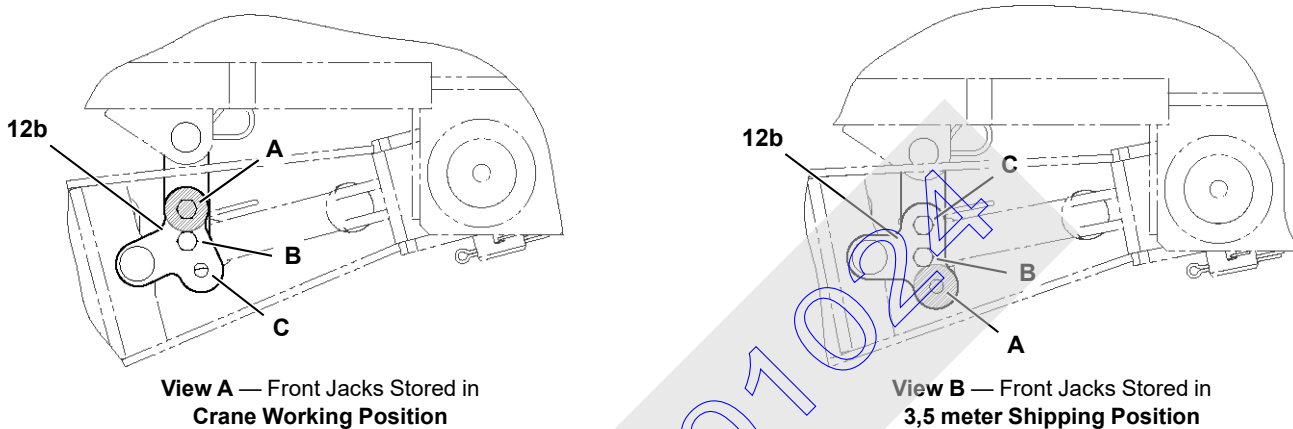

FIGURE 4-9

Legend for [Figure 4-9](#) and [Figure 4-10](#)

Item	Description	Item	Description
1	Rotating Bed	8	Pin with Hair-Pin Cotter
2	Jack (4 each)	9	Compression Link
3	Operator's Cab	10	Strut
4	Trailer	11	Pin — 1-1/8 in (28.6 mm) Dia x 4-3/4 in (60.3 mm) Long
5	Lifting Lug (2 each jack)	12a	Link (rear)
6	Fixed Pin in Jack	12b	Link (front)
7	Fixed Pin in Rotating Bed	13	Pin — 1-1/8 in (28.6 mm) Dia x 5 in (127 mm) Long



**NOTE** Links (12b) must be assembled as shown for desired working or shipping position. Note location of shaded lug and hole A.

**FIGURE 4-10**

**Deploy Rotating Bed Jacks**

See [Figure 4-9](#) for the following procedure.

**NOTE** If rotating bed is shipped with jacks installed, go directly to step 2.

1. If jacks are not installed, proceed as follows:
  - a. Connect lifting slings from assist crane to lifting lugs (5, View B) on jack (2).
  - b. Lift jack (2) into position so fixed pin (6, View B) in jack engages hole in rotating bed and fixed pin (7) in rotating bed engages hole in jack frame.
  - c. Lower jack into position and disconnect assist crane.
  - d. Remove pin (8, View C) holding compression link (9) in stored position.
  - e. Swing compression link into working position and install pin (8, View C) in working position.

- f. Remove strut (10, View D or F) and link (12a or 12b) from stored position.
  - g. Install strut (10, View C or E) and link (12a or 12b) to secure jack in working position.
  - h. Repeat step 1a through 1g for remaining jacks.
  - i. Go to step 3.
2. If rotating bed is shipped with jacks installed, proceed as follows:
    - a. Remove pin (11a, View D or F) holding jack (2) in stored position.
    - b. Rotate jack to working position.
    - c. Remove strut (10, View D or F) from stored position.
    - d. Install strut (10, View C or E) and link (12a or 12b) to secure jack in working position.
    - e. Go to step 3.



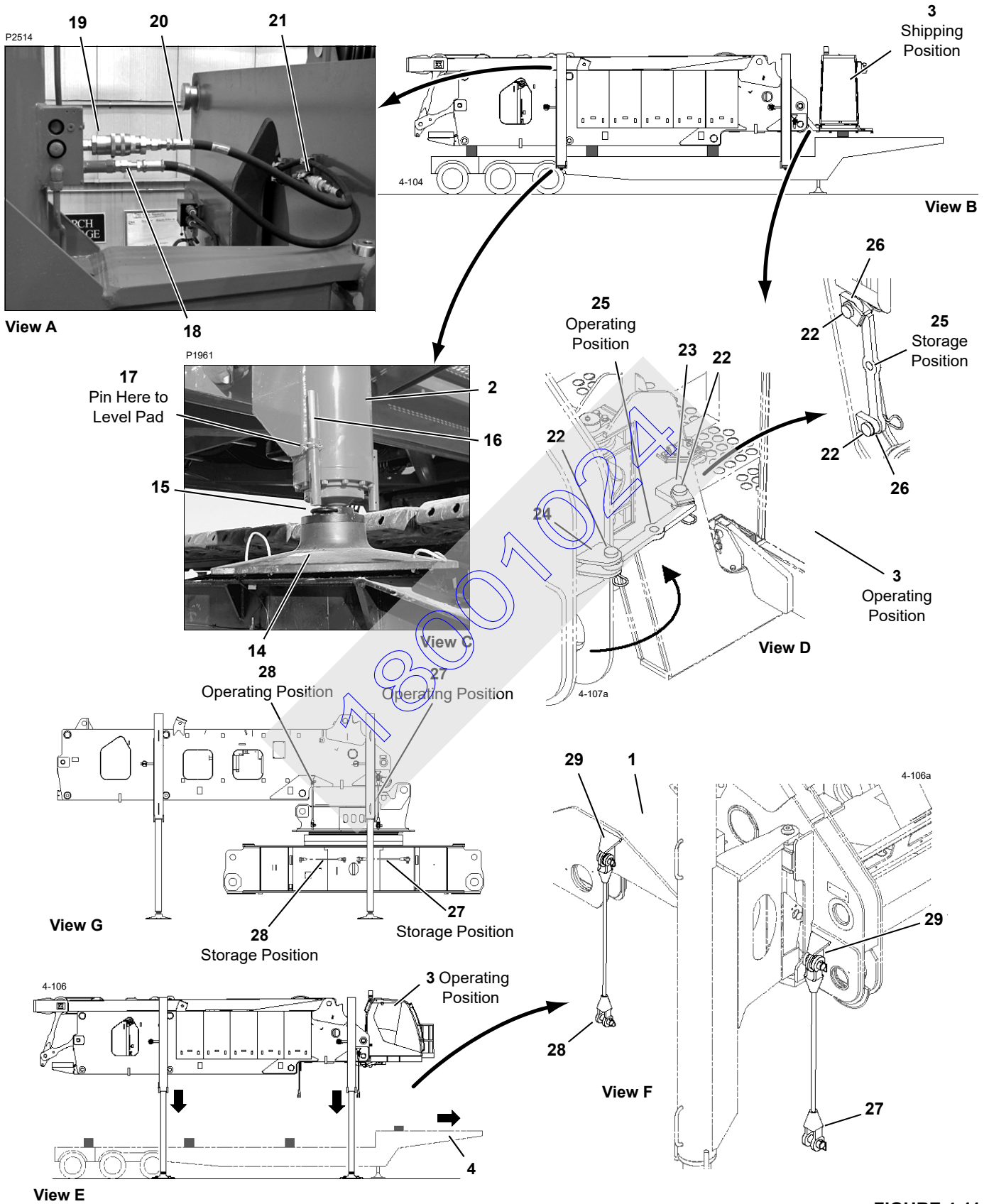

FIGURE 4-11



Legend for [Figure 4-11](#)

Item	Description
1	Rotating Bed
2	Jack (4 each)
3	Operator's Cab
4	Trailer
See <a href="#">Figure 4-9</a> for Items 5 through 13	
14	Jack Pad
15	U-Shaped Locking Pin
16	Jack Pad Support Rod
17	Hair-Pin Cotter
18	Hose from Jack
19	Coupler on Jack
20	Hose from Rotating Bed
21	Coupler on Rotating Bed
22	Pin with Hair-Pin Cotter
23	Lug (cab support)
24	Lugs (rotating bed)
25	Strut
26	Lug (strut storage)
27	Front Alignment Pendant with Pins and Hair-Pin Cotters — 1-1/8 in (28.6 mm) Dia x 58 in (1 473 mm) Long
28	Rear Alignment Pendant with Pins and Hair-Pin Cotters — 7/8 in (22.2 mm) Dia x 52in (1 321 mm) Long
29	Lug

3. Remove jack pads (14, View C) from storage (see [Figure 4-7](#)) and fasten them to jacks with U-shaped locking pins (15).

4. Pin pad support rod (16, View C) in retracted position so jack pad hangs freely (parallel with ground). **Damage will occur if this step is not performed.**

5. Connect hydraulic hoses at each jack:

See [Figure 4-11](#), View A for the following procedure.

- Disconnect hose (18) from coupler (19) on jack.
- Disconnect hose (20) from coupler (21) on rotating bed.
- Connect hose (18) from jack to coupler (21) on rotating bed.
- Connect hose (20) from rotating bed to coupler (19) on jack.

**Alignment Pendants**

- Remove alignment pendants from right and left sides of carbody (27 and 28, View G).
- Pin alignment pendants (27 and 28, View F) to lugs (29, View D) on both sides of rotating bed.

**Deploy Operator's Cab**

See [Figure 4-11](#), View D for the following procedure.

**NOTE** It may be necessary to extend jacks to raise cab off trailer.

- Remove pin (22) securing cab support lug (23) to rotating bed lugs (24).
- Rotate cab (3) 90° to operating position.
- Unpin strut (25) from storage lugs (26).
- Pin strut (25) between cab support lug (23) and rotating bed lugs (24) with two pins (22).
- Store extra pin (22) in storage lug (26).

**Jack Upperworks Off Trailer**

See [Figure 4-11](#) for the following procedure.

- Remove tie-downs securing rotating bed to trailer.
- Using remote control, fully extend jacks to lift upperworks off trailer (View E). **Rotating bed must not be more than 3° out of level while jacking.**
- Remove trailer. **Take extreme care not to hit jacks with trailer. Provide a signal person to give instructions to truck driver.**

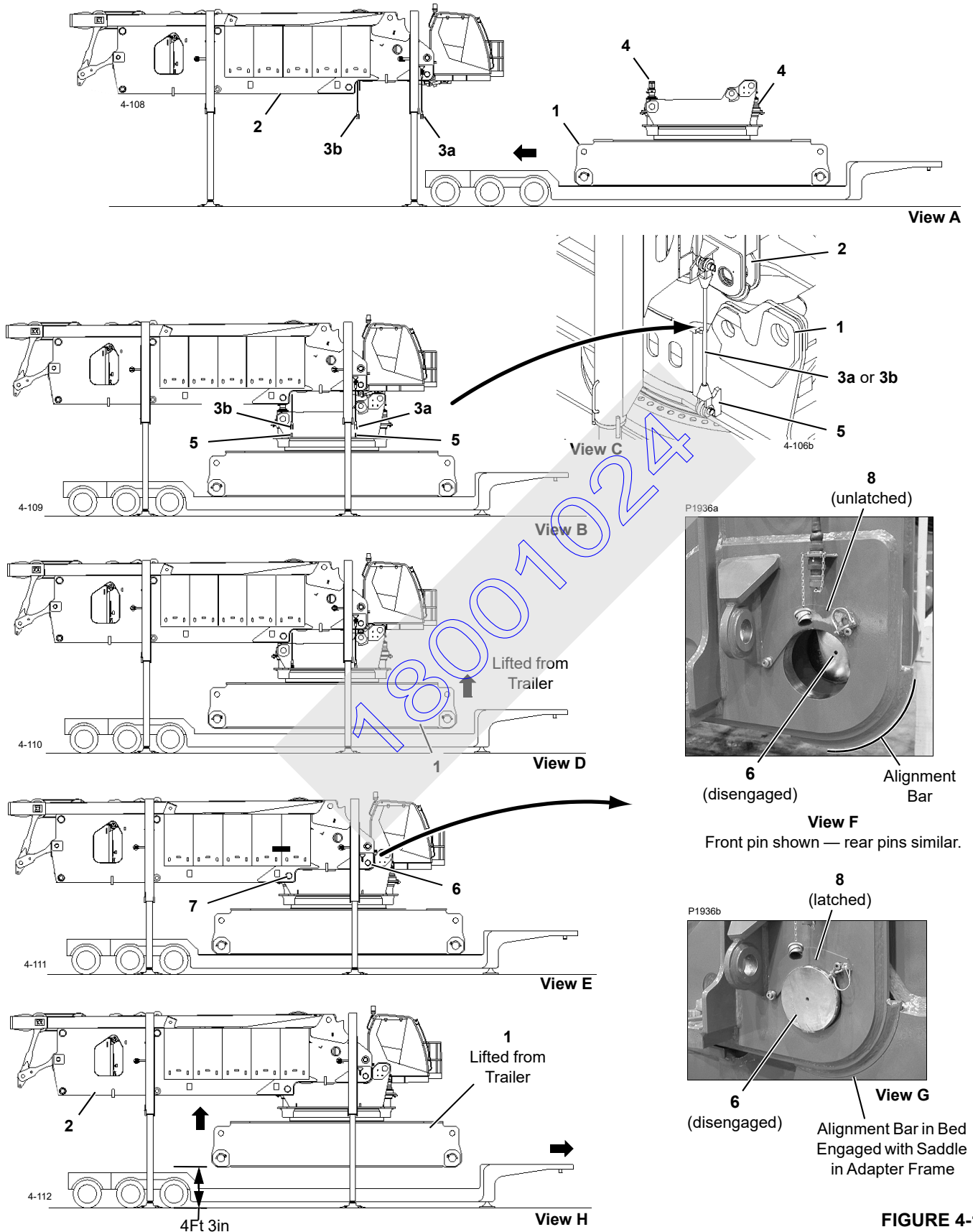

FIGURE 4-12

## Remove Carbody and Adapter Frame from Trailer

See [Figure 4-12](#) for the following procedure.

1. Position trailer carrying adapter frame and carbody (1, View A) directly under rotating bed (View B).

### CAUTION

#### Equipment Damage!

Use extreme care when backing trailer into position:

- Do not hit jacks with trailer.
- Do not hit swing motors with rotating bed.

Provide a signal person to give instructions to truck driver.

2. Position trailer so alignment pendant lugs (5, View C) on carbody are directly under alignment pendants (3a and 3b) hanging from rotating bed.
3. Retract jacks only enough so alignment pendants can be pinned. **Rotating bed must not be more than 3° out of level when retracting jacks.**
4. Pin front and rear alignment pendants (3a and 3b, View C) to alignment pendant lugs (5).
5. Remove tie-downs securing adapter frame and carbody to trailer.
6. Slowly extend jacks to lift adapter frame and carbody (1) just clear of trailer (View D).

Alignment pendants will center adapter frame and carbody under rotating bed.

## Connect Rotating Bed to Carbody

See [Figure 4-12](#) for the following procedure.

**NOTE** *Rotating bed must not be more than 3° out of level when extending or retracting rotating bed jacks.*

1. Unlatch front and rear keeper plates (8, View F) and disengage front and rear rotating bed pins (6 and 7, Views E and F) with switches on remote control.

With rotating bed pins disengaged, grease them. See Section 5 of this manual.

2. Slowly retract jacks to lower adapter frame and carbody back onto trailer (View E).

**NOTE** Adjust jacks so front of rotating bed is slightly lower than rear of rotating bed.

3. Continue to lower upperworks with jacks until alignment bars on front of rotating bed (View F) are engaged with saddles on front of adapter frame (View G). Front mounting holes should be in line.

### CAUTION

Do not lower entire weight of upperworks onto adapter frame. Weight may exceed trailer capacity.

4. Engage front rotating bed pins (6, View G) with switch on remote control.
5. Lower rear jacks until rear mounting holes line up.
6. Engage rear rotating bed pins (7).
7. Secure pins with keeper plates (8, View G) and retaining pins.
8. Fully extend jacks to lift upperworks, adapter frame, and carbody off trailer (View H).
9. Remove trailer. **Take extreme care not to hit jacks with trailer. Provide a signal person to give instructions to truck driver.**
10. Remove and store alignment pendants.

### Legend for [Figure 4-12](#)

Item	Description	Item	Description
1	Adapter Frame and Carbody	5	Alignment Pendant Lug – Carbody (four places)
2	Rotating Bed	6	Rotating Bed Connecting Pin – Front (two places)
3a	Front Alignment Pendant (two places)	7	Rotating Bed Connecting Pin – Rear (two places)
3b	Rear Alignment Pendant (two places)	8	Keeper Plate (four places)
4	Swing Motor (four places)		

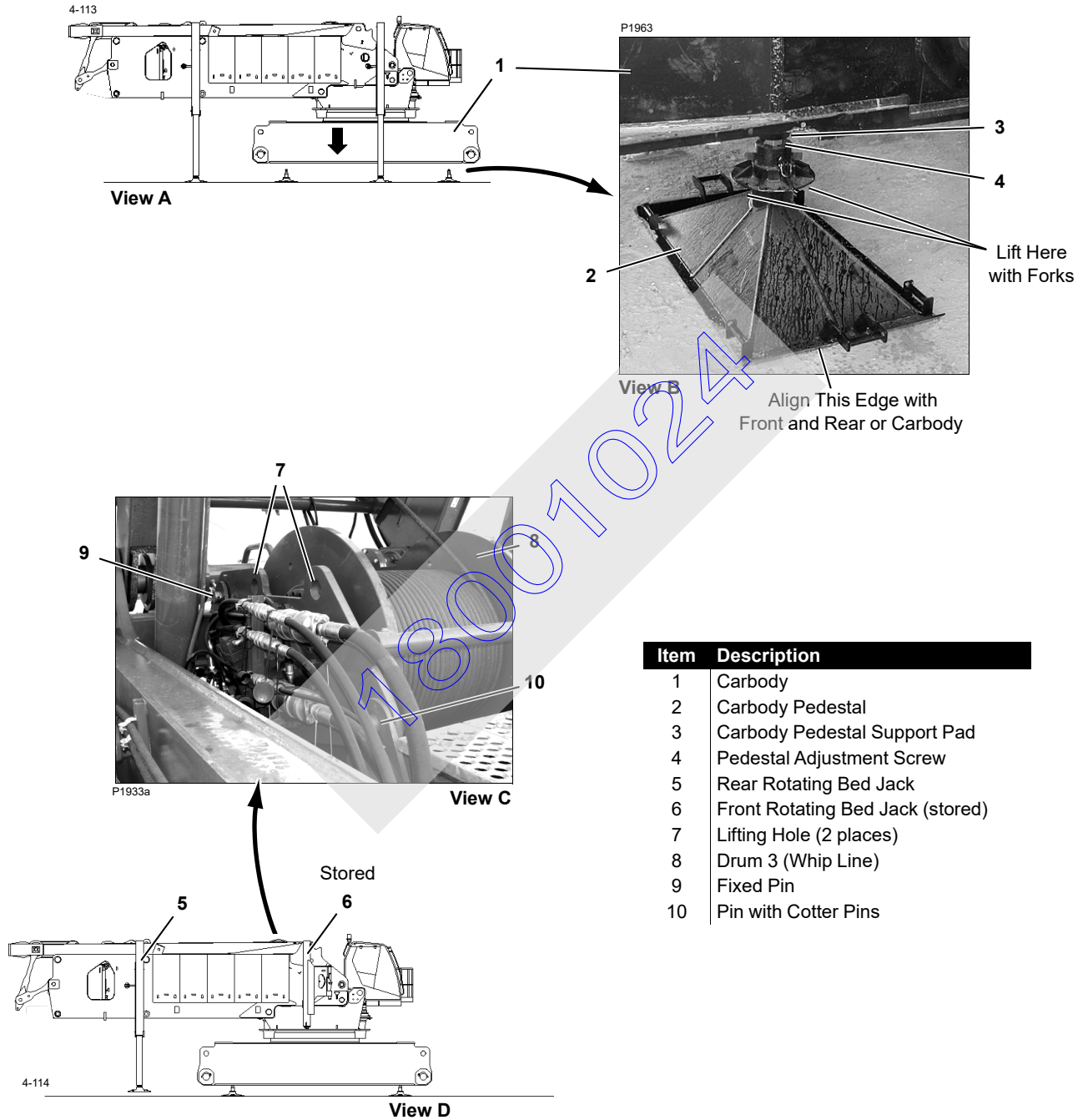

Item	Description
1	Carbody
2	Carbody Pedestal
3	Carbody Pedestal Support Pad
4	Pedestal Adjustment Screw
5	Rear Rotating Bed Jack
6	Front Rotating Bed Jack (stored)
7	Lifting Hole (2 places)
8	Drum 3 (Whip Line)
9	Fixed Pin
10	Pin with Cotter Pins

FIGURE 4-13

## Lower Crane onto Carbody Pedestals

See [Figure 4-13](#) for the following procedure.

1. Remove four carbody pedestals (2) from storage.
2. Place pedestals under carbody support pads (3, View B) so short sides of pedestals are parallel to front and rear sides of carbody.
3. Retract rotating bed jacks to lower carbody onto four pedestals.
4. Adjust pedestal screws (4, View B), as required, to level carbody. Carbody must be as level as possible for crawler installation.
5. Retract rear jacks (5, View D) until pads are approximately 6 in (152 mm) off the ground.
6. Retract front jacks slightly, remove front jack pads and store (see [Figure 4-7](#)).
7. Fully retract both front jacks and store as follows:
  - a. Remove strut (10, [Figure 4-9](#), View E) from working position and store ([Figure 4-9](#), View F).
  - b. Swing jack rearward to stored position against rotating bed and pin ([Figure 4-9](#), View F).

**NOTE** Before storing the front jacks if they were shipped with the crane in the 11.4 ft (3,5 m) shipping position ([Figure 4-10](#), View B), links (12b) must be reassembled to the arrangement shown in ([Figure 4-10](#), View A).

18001024

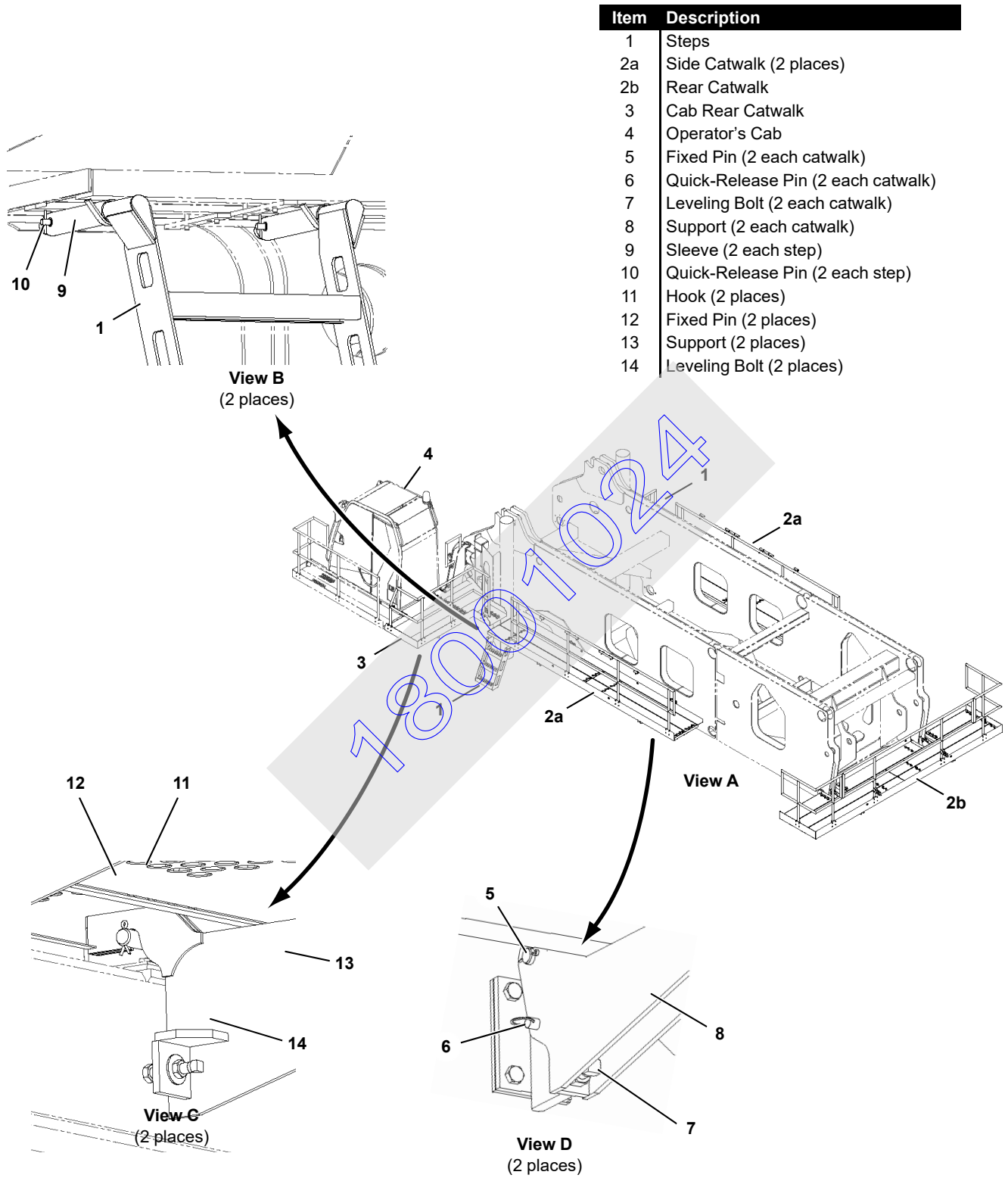

4

FIGURE 4-14

## Install Rotating Bed Catwalks and Steps (Past Production)

### Side and Rear Catwalks

See [Figure 4-14](#), View D for the following procedure.

1. Using chain slings from assist crane connected to four lifting holes in catwalk, lift catwalk (2a or 2b) into position so fixed pins (5) in catwalk fully engage hooks on side or rear of rotating bed.
2. Install quick-release pins (6) to lock catwalk in place.
3. Level catwalk as required after installation with two leveling bolts (7).
4. Repeat preceding steps for each catwalk.

### Steps

See [Figure 4-14](#), View B for the following procedure.

1. Using nylon slings from assist crane, lift steps (1) into position alongside either catwalk.
2. Slide tubes at top of steps through sleeves (9) on underside of catwalk.
3. Install quick-release pins (10) to lock steps in place.
4. Repeat preceding steps for steps on other side.

### Cab Rear Catwalk

See [Figure 4-14](#), View C for the following procedure.

1. Using nylon slings from assist crane, lift catwalk (3) into position so hooks (11) in catwalk fully engage fixed pins (12) on rear of cab.
2. Level the catwalk as required after installation with two leveling bolts (14).

18001024



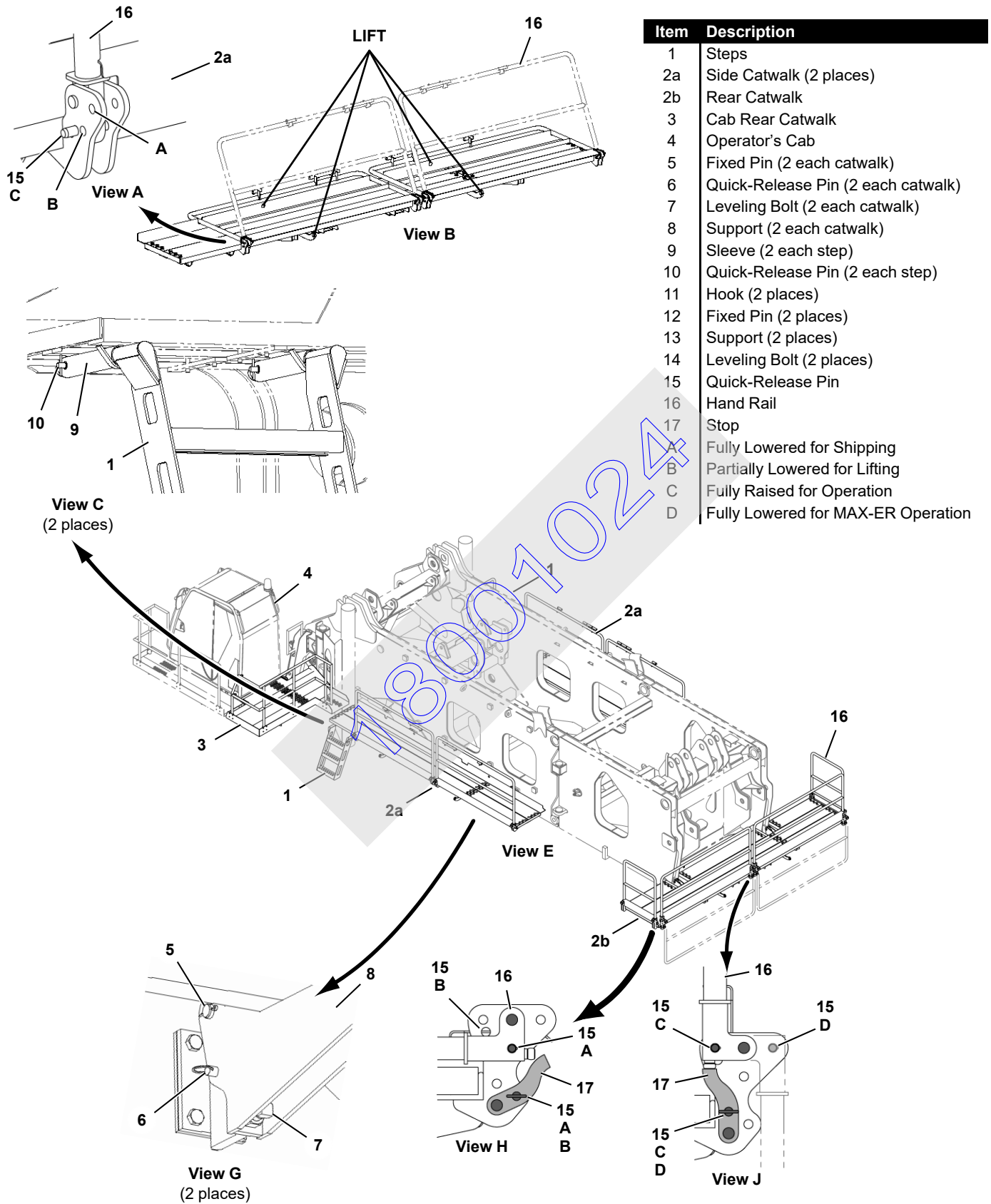

4

FIGURE 4-15

## Install Rotating Bed Side and Rear Catwalks and Steps (Current Production)

### Side and Rear Catwalks

See [Figure 4-15](#) for the following procedure.

1. Lift catwalks using chain slings from assist crane connected to four lifting holes as shown in View B.

**NOTE** The catwalks can be lifted with the handrails fully lowered or partially raised.

2. Lift catwalk (2a or 2b) into position so fixed pins (5, View G) in catwalk support (8) fully engage hooks on side or rear of rotating bed.
3. Install quick-release pins (6, View G) to lock catwalk in place.
4. Level catwalk as required after installation with two leveling bolts (7, View G).
5. Repeat preceding steps for each catwalk.
6. Pin handrails (16 Views A, G, and H) in fully raised position.
7. If crane will be equipped with a MAX-ER attachment, fully lower handrails (16) to rear of crane (View H).

### Steps

See [Figure 4-15](#), View C for the following procedure.

1. Using nylon slings from assist crane, lift steps (1) into position alongside either catwalk.
2. Slide tubes at top of steps through sleeves (9) on underside of catwalk.
3. Install quick-release pins (10) to lock steps in place.
4. Repeat procedure for steps on other side.

## Connect Hydraulic Hoses and Electric Cables

1. Uncouple hydraulic hoses on sides of adapter frame and rotating bed ([Figure 4-18](#), View C).
2. Connect hydraulic hoses on both sides of adapter frame and rotating bed ([Figure 4-18](#), Views F and G). Hoses must run in a straight line between adapter frame and rotating bed.

**NOTE** On current production cranes, hoses and corresponding couplers are tagged with numbers (see [Figure 4-18](#), View L). Match numbers to ensure proper hose connection.

3. Connect electric cable (3, [Figure 4-18](#), View B) to cable (1, View A).

## Install Drum 3 (Whip Line Drum)

Perform this procedure only if Drum 3 will be used for an additional load line.

See [Figure 4-12](#), View C for the following procedure.

1. Connect legs of chain sling from assist crane to lifting holes (7) in Drum 3 (8).
2. Lift drum into position over rotating bed. Hydraulic couplings on drum must face left side of bed.
3. Engage slots in front of drum with fixed pins (9) and align rear connecting holes.
4. Install rear pins (10).
5. Connect four hydraulic hoses from rotating bed to couplers on drum. Hoses can be connected only one way.
6. Connect three electric cables from rotating bed to drum.

Item	Description
1	Cab Left Platform
2	Hex Head Cap Screw (.5-13 X 1.00 G5)
3	Flat Washer (.5" SST)
4	Quick Release Pin (15.88 DIA X 63.5 LG)
5	Platform Weldment
6	Cotter Pin (1/8" dia. X 6.5" LG)
7	1-Hole Pin
8	Rubber Bumper
9	Quick Release Pin (15.9 DIA X 25.4 LG)
10	Cab Left Handrail
11	Cab Front Handrail
12	Cab Front Handrail Wing

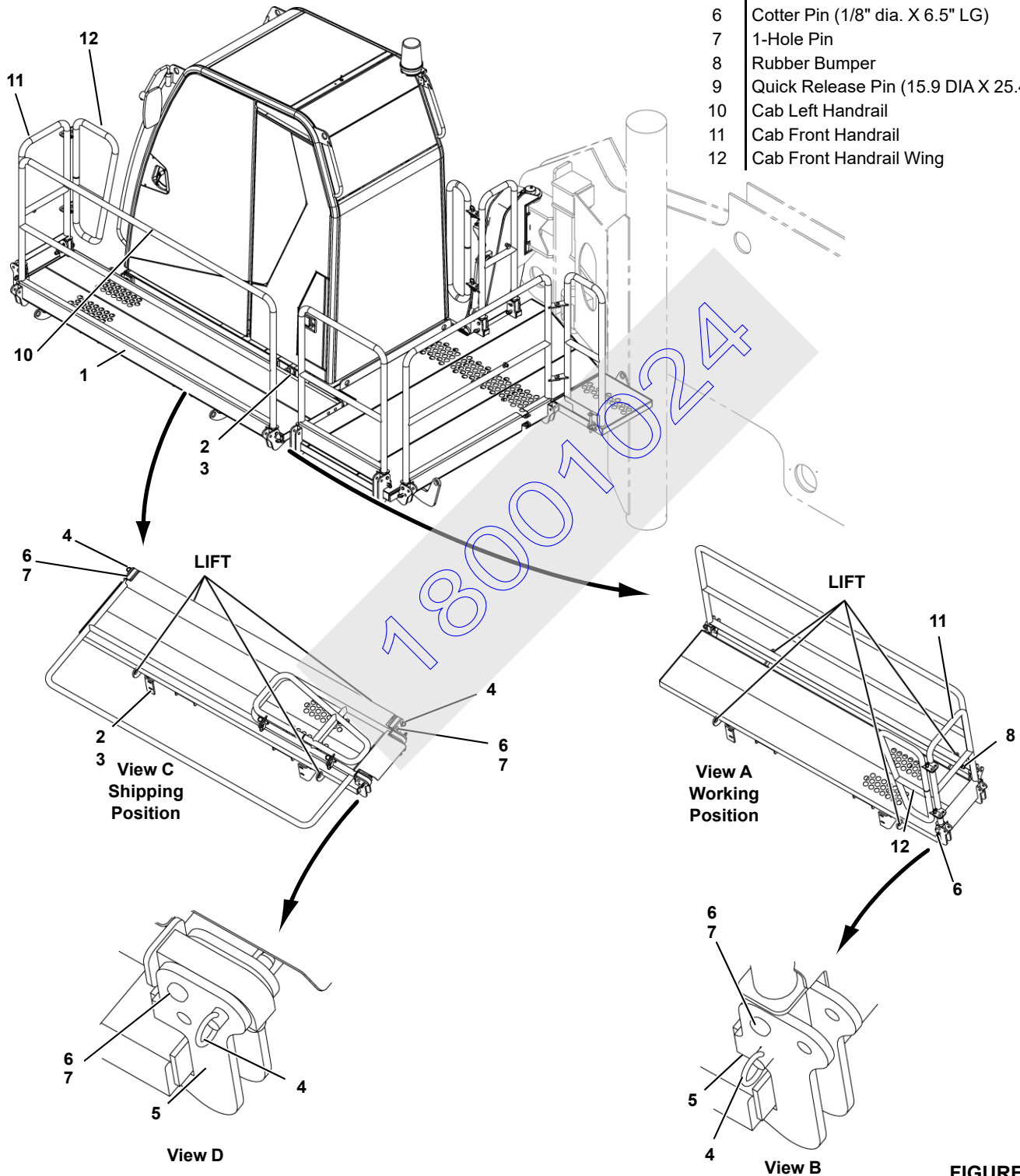

4

FIGURE 4-16

### Install Cab Left Platform (Current Production)

See [Figure 4-16](#) for the following procedure.

**NOTE** Fork pockets are included in the platform floor for handling by a fork truck.

1. Remove two quick release pins (4, Views E and F) to rotate cab front handrail assembly (11 and 12) about pins (6).
2. Raise front handrail assembly (11 and 12) into working position (View A) and secure by inserting quick release pins (4, two places, Views B and G) into working position holes in platform weldment (5).
3. Remove two quick release pins (9, Views G and H) from weldments to allow movement of front handrail wing (12).
4. Rotate handrail wing (12, Views G and H) about its "hinge" 270° into working position and secure by

- inserting quick release pins (9) into working position holes in weldments (5).
5. Remove quick release pin (4, two places, Views C and E) from left handrail (10) to allow movement of handrail about pins (6).
6. Rotate left handrail (10, View H) into lifting position and secure by inserting quick release pins (4) into lifting position holes in weldment (5).
7. Lift cab left platform (1, Views A and C) using chain slings from assist crane connected to four lifting holes.
8. Move cab left platform (1) into position so holes in cab assembly (View C) align with slotted holes in platform assembly (1). Secure with washers (3) and hex head capscrews (2) (four places).
9. Remove chain slings.

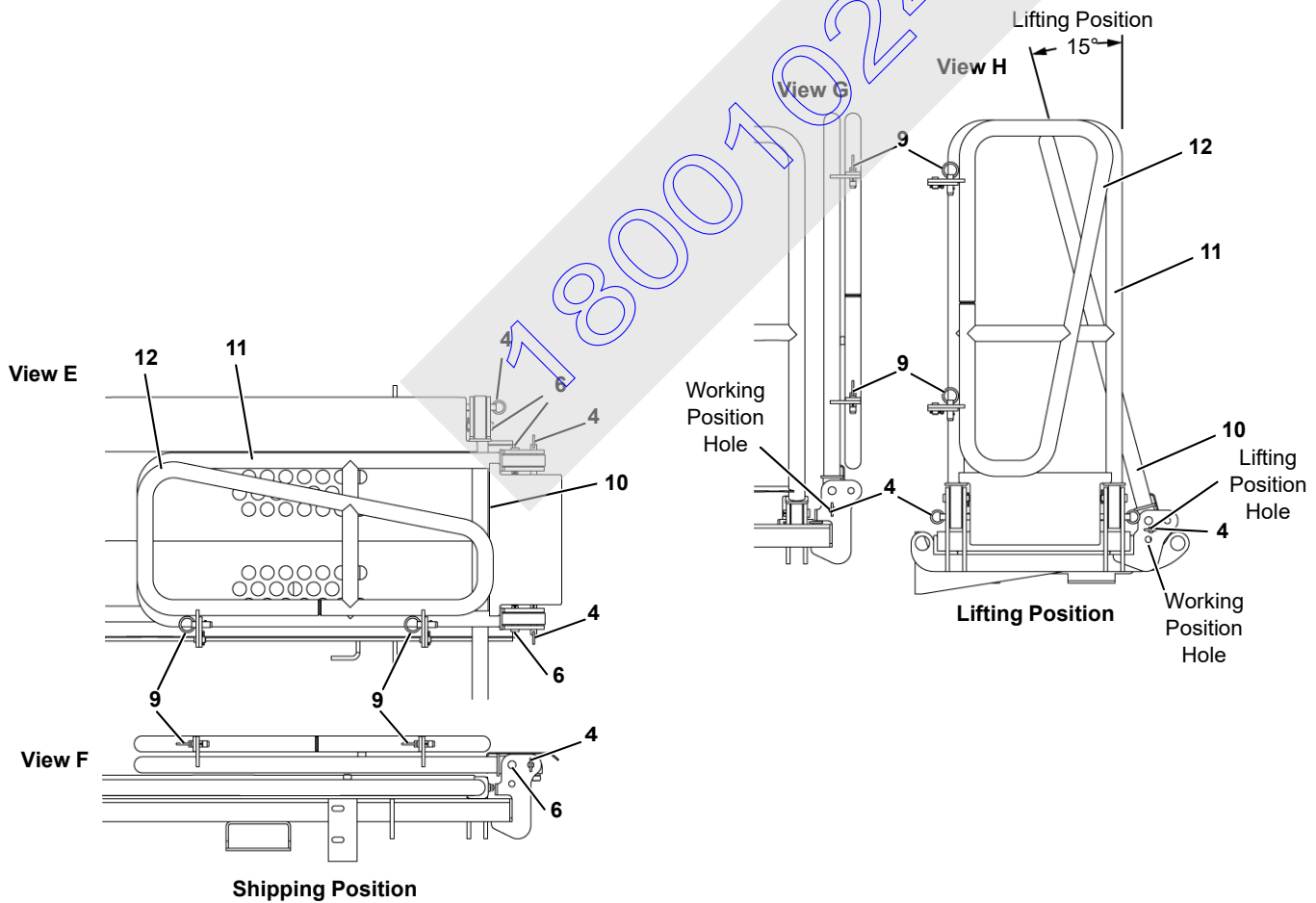

FIGURE 4-16 continued

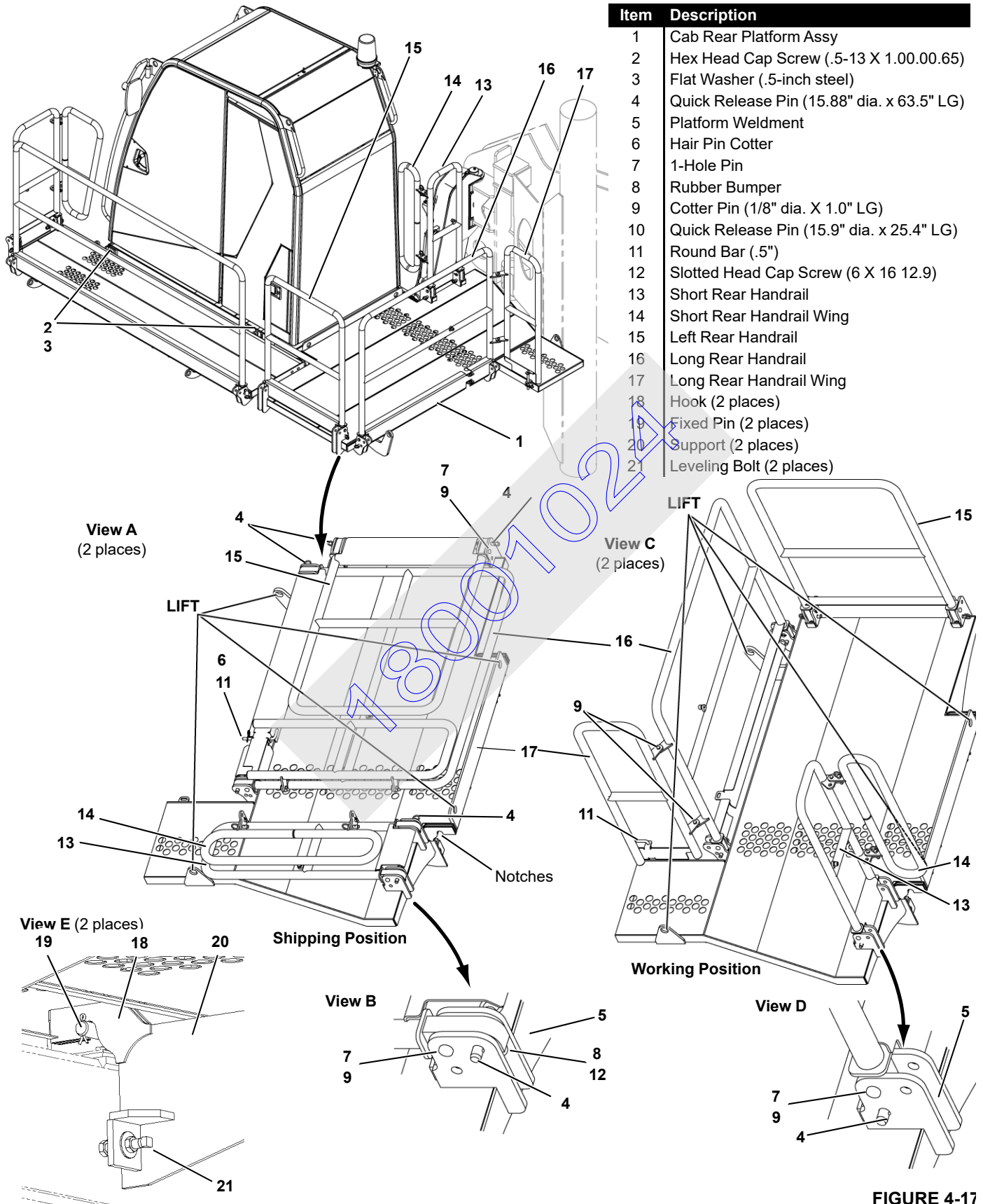

FIGURE 4-17



### Install Cab Rear Platform (Current Production)

See [Figure 4-17](#) for the following procedure.

**NOTE** Fork pockets are included in the platform floor for handling by a fork truck.

1. Remove quick release pins (4) from short rear handrail assembly (13 and 14, View A) to allow movement of assembly about pins (9, View B).
2. Raise short rear handrail assembly (13 and 14, Views C and D) into working position and secure by inserting quick release pins (4, two places, View D) into working position holes in platform weldment (5).
3. Remove quick release pins (4) from left rear (15, View A) and long rear (16 and 17) handrails.
4. Raise left rear handrail section (15, Views A and C) into working position and secure by inserting quick release pins (4, View D) into working position holes in platform weldment (5).
5. Raise long rear handrail assembly (16 and 17, Views A, C and H) into lifting position and secure by inserting quick release pins (4, View A) into **lifting** position holes in weldment (View I).
6. Lift cab rear platform (1) into position using chain slings from assist crane connected to four lifting holes (Views A and C). Hooks (18, View E) in platform catwalk should fully engage fixed pins (19) on rear of cab.

7. Remove chain slings from lifting holes in platform assembly.
8. Level the platform's catwalk as required after installation with two leveling bolts (21).

### Move Platforms into Working Positions (Current Production)

See [Figure 4-17](#) for the following procedure.

1. Remove quick release pins (10, View H) from weldments to allow movement of short rear handrail wing (14) around pins (6).
2. Rotate short rear handrail wing (14) 90° into working position (View C) and secure by inserting quick release pins into working position holes in weldments (View J).
3. Remove quick release pins (4, View I) from long rear handrail assembly (16 and 17), carefully rotate assembly into the **working** position and secure by inserting same quick release pins into working position holes.
4. Rotate rear handrail wing (17, View C) 90° about pins (9) into working position and secure by inserting round bar (11, Views G and H) into holes in weldments.
5. Remove quick release pins (4, Figure 4-16, View H) from long handrail (10), rotate to **working** position and secure by inserting quick release pins (4) into working position holes in weldment (5).

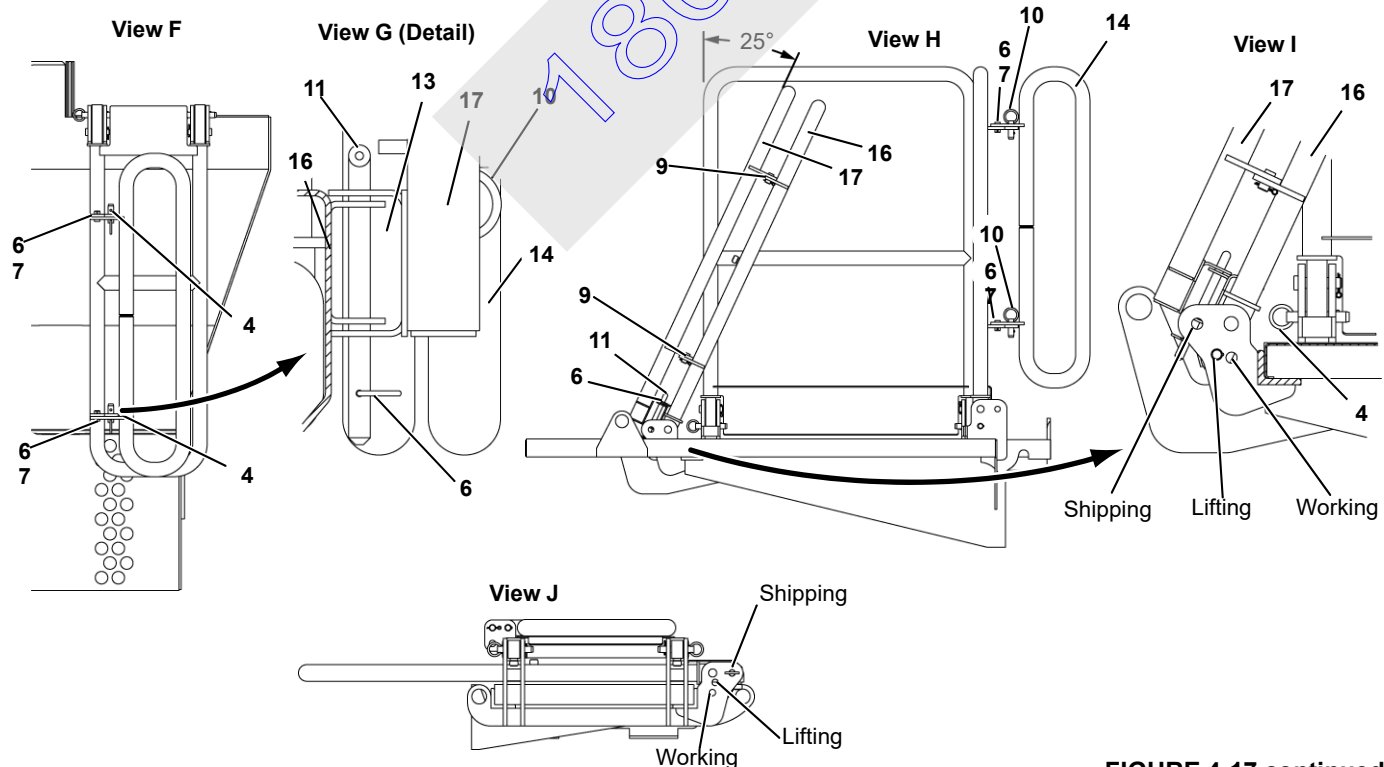

FIGURE 4-17 continued

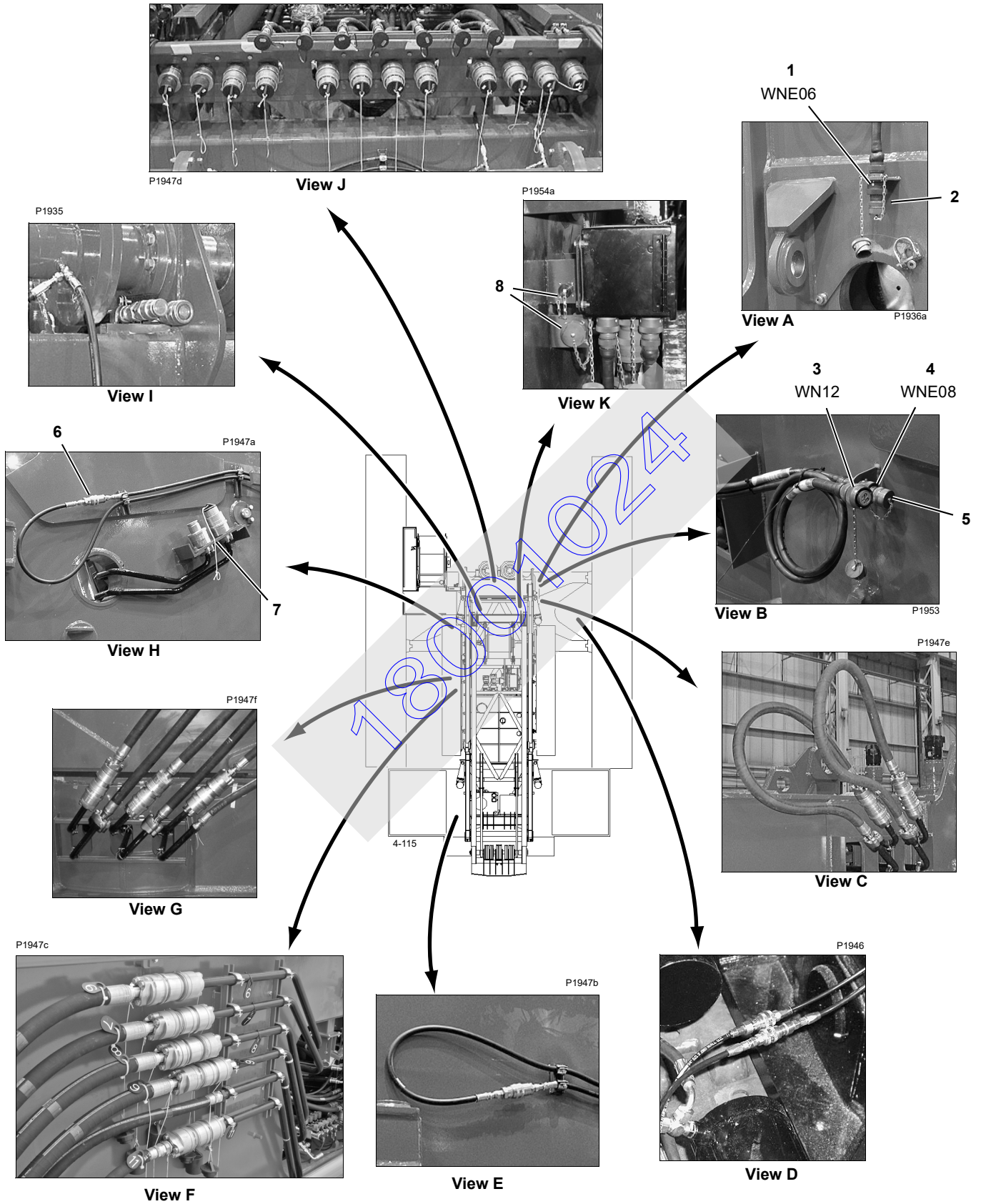

FIGURE 4-18



Legend for [Figure 4-18](#)

View	ID	Type	Purpose	Comment
<b>Ends of all disconnected cables and hoses must be covered with closures or sealing caps (or looped together) to protect them from water and dirt.</b>				
A	1	Electric	Cable From Rot Bed Node 6	Connect to cable (3) when connecting rotating bed to adapter frame.
	2	Electric	Terminating Plug	Must be plugged to cable (1) until rotating bed is connected to adapter frame.
B	3	Electric	Cable From Adapter Frame Node 7	Connect to cable (1) when connecting rotating bed to adapter frame.
	4	Electric	Boom Cable from Adapter Frame Node 7	Connect to cable (WN18) from boom Node 8 when connecting boom butt to rotating bed.
	5	Electric	Terminating Plug	Must be plugged to cable (4) until boom butt is connected to rotating bed and all cables are connected in boom.
C	—	Hydraulic	Adapter Frame to Carbody	4 hoses right side; 6 hoses left side (NOTE 1).
D	—	Grease	Lubricate Crawler	2 lines each crawler (NOTE 2).
E	—	Hydraulic	Rotating Bed Rear Jack	2 hoses each side (NOTE 2).
F, G	—	Hydraulic	Rotating Bed/Adapter Frame	6 hoses left side; 5 hoses right side (NOTE 3).
H	6	Hydraulic	Rotating Bed Front Jack	2 hoses each side (NOTE 2).
H	7	Hydraulic	Drum 4 (Boom Hoist) in Mast Butt	2 hoses each side (NOTE 4).
I		Hydraulic	Drum 4 (Boom Hoist) in Mast Butt	2 hoses left side (left side shown); 3 hoses right side (NOTE 4).
J		Hydraulic	Drums in Boom	Quantity on front of rotating bed varies (NOTE 5).
K	8	Electric	Drum 4 (Boom Hoist) in Mast Butt	2 Receptacles.

- NOTE 1** Loop together for shipping.
- NOTE 2** Loop together for shipping. Can be connected one way only (see NOTE 6).
- NOTE 3** Loop together for shipping. Hoses must run in a straight line between rotating bed and adapter frame (see NOTE 6).
- NOTE 4** Loop hoses in mast together for shipping. Can be connected one way only.
- NOTE 5** Hoses run in a straight line between boom butt and rotating bed (see NOTE 6)
- NOTE 6** On current production cranes, hydraulic hoses and corresponding couplers have numbered tags (see View L). Match numbers to ensure proper hose connection.

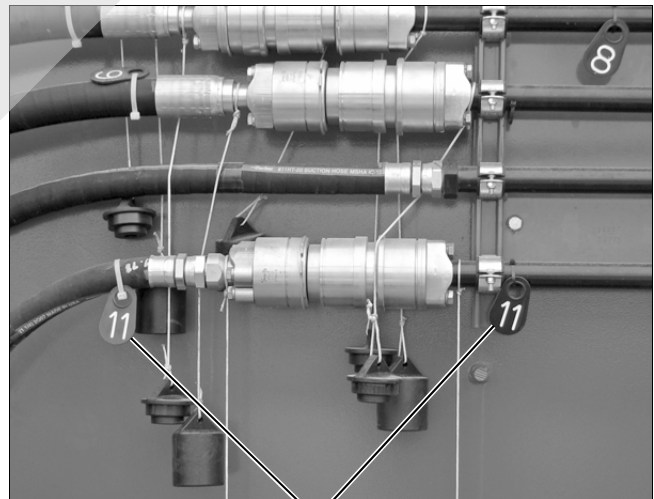

Match numbers to ensure proper hose connection.

View L

### Configure Enclosure Panels

See [Figure 4-19](#) for the following procedure.

**NOTE** This procedure only applies to crane when shipped with front of rotating bed facing truck cab (shipping position 2).

### Working Position

1. Reposition enclosure panels on both sides of crane by swapping sides with panels (1) and (2) and relocating to the rear of the rotating bed.

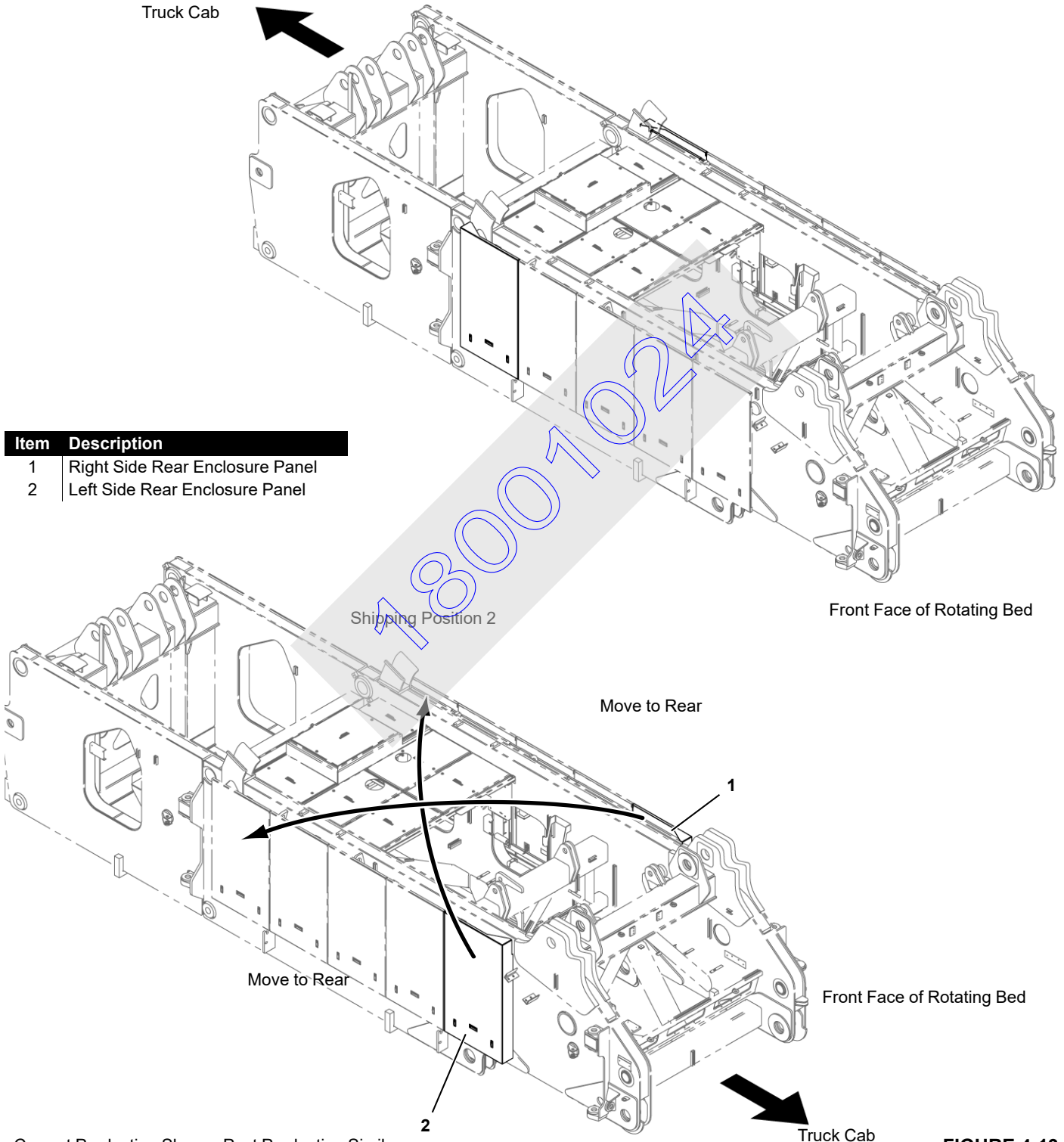

Current Production Shown; Past Production Similar

**FIGURE 4-19**

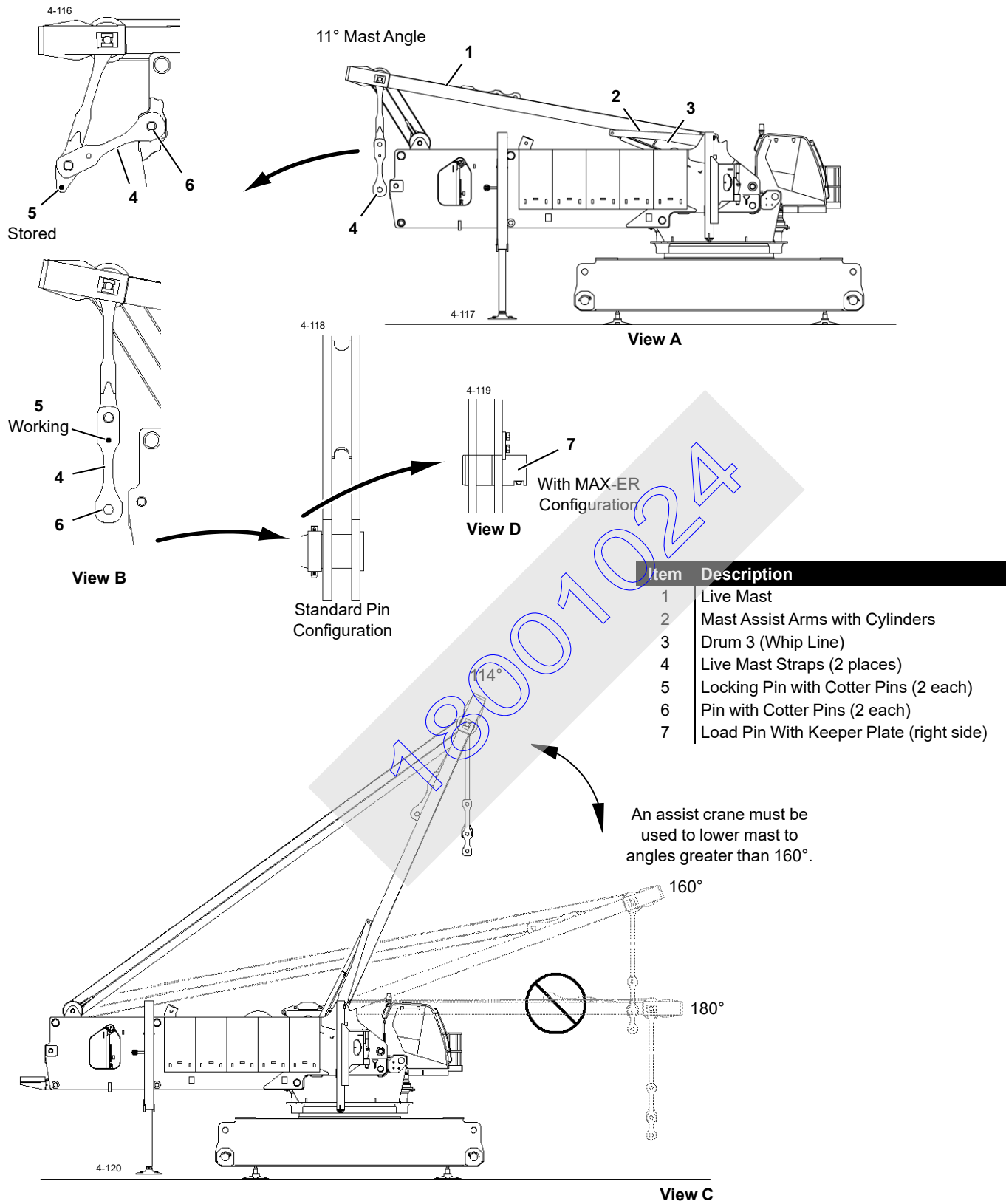

FIGURE 4-20

## Raise Live Mast To Operating Position

See [Figure 4-20](#) for the following procedure.

The following controls are used to raise the mast. See Operating Controls in Section 3 for identification and operation of these controls.

- CRANE MODE SELECTOR (in operator's cab) to select setup mode.
  - Live mast controls will not operate until setup mode is selected and confirmed.
  - Live mast operating limits remain off until setup mode is selected and confirmed.
- MAST HOIST CONTROL (Drum 5 handle in operator's cab) to raise and lower mast while using mast as a boom.
- MAST SWITCH on remote control to raise and lower mast assist arms.
- DIGITAL DISPLAY (in operator's cab) to monitor mast angles and operating limits. See Digital Display Readings in Section 3 for identification of mast operating limits.

### **WARNING** Falling Mast Hazard!

Prevent mast from falling over backwards or forward.

- Read and thoroughly understand mast raising instructions.
- Select and confirm **SETUP MODE** before raising mast and using it as a boom. Mast operating limits remain off until this step is performed.

### **CAUTION** Mast Damage!

Make sure mast angle indicator is properly installed and calibrated prior to raising gantry and mast.

Mast can be damaged if angle indicator is not properly installed.

1. Remove locking pins (5) from stored position in mast straps (4, View B).
2. Select and confirm **SETUP MODE**.

3. Scroll to **MAST ANGLE** on digital display to monitor mast angles during raising procedure.
4. Increase engine speed to desired RPM.
5. Using mast switch on remote control, raise mast assist arms until cylinders stall and stop.

Operating limit alert comes on and **MAST BELOW 2 DEGREES** appears on digital display if you try to raise mast with mast hoist control before you perform step 5.

6. **MAST DOWN** with mast hoist control (Drum 5) to begin raising live mast to operating position.

Mast will rise as mast assist arm cylinders (2, View A) extend automatically.

**NOTE** Do not use **BOOM HOIST** control (Drum 4) to raise mast. Mast assist cylinders will not extend. Boom hoist wire rope will pay out.

### **CAUTION** Mast Damage!

Unpin mast straps from rotating bed before raising mast past 11°.

7. **STOP** raising mast just as mast straps (4) start to go into tension (mast angle approximately 11°) (View A).

### **WARNING** Swinging Straps Hazard!

Mast straps will swing to rear when unpinned from rotating bed. Stand to side when unpinning links.

8. Support straps (4), remove pins (6, View B) to unpin straps from rotating bed, and lower straps to vertical.

Store pins (6) with collar in strap holes. If a MAX-ER attachment is used, a load pin with keeper plate (7, View D) is right side pin.

9. Install locking pins (5, View B) in working position.
10. **MAST DOWN** to continue raising mast.

Mast assist arms will stop rising automatically when mast assist cylinders are fully extended (approximately 114°) as shown in View C.

Continued on [page 4-33](#).

A1258

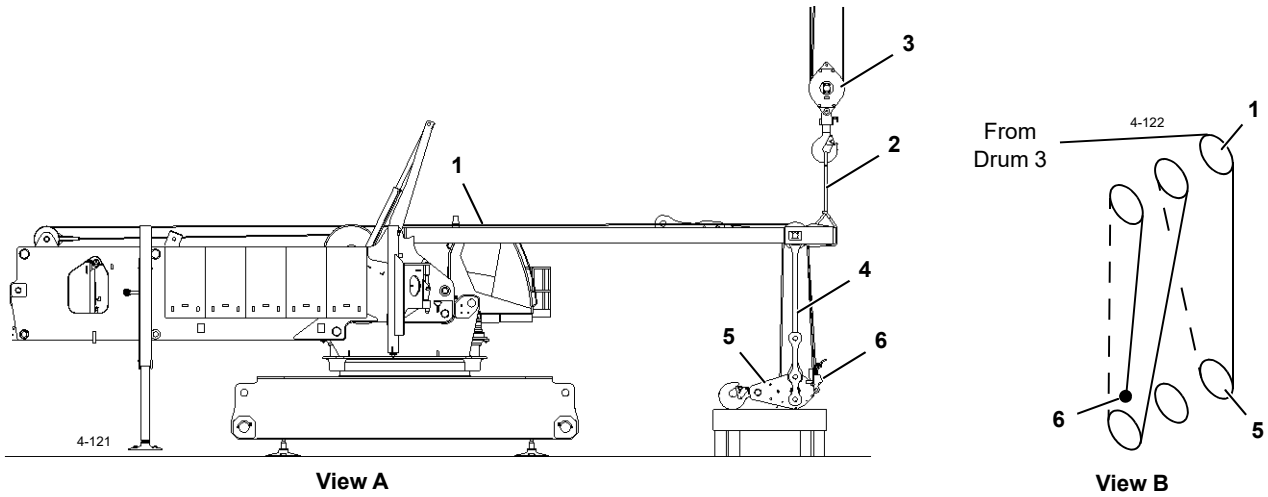

**MAXIMUM CAPACITY**  
120,000 lb (54 430 kg) at 26 ft (7,9 m) Radius

Item	Description
1	Live Mast
2	Owner-Furnished Nylon Slings
3	Assist Crane Load Block
4	Mast Straps
5	100 USt Load Block (91 t)
6	Socket and Wedge
7	4-Leg Chain Sling

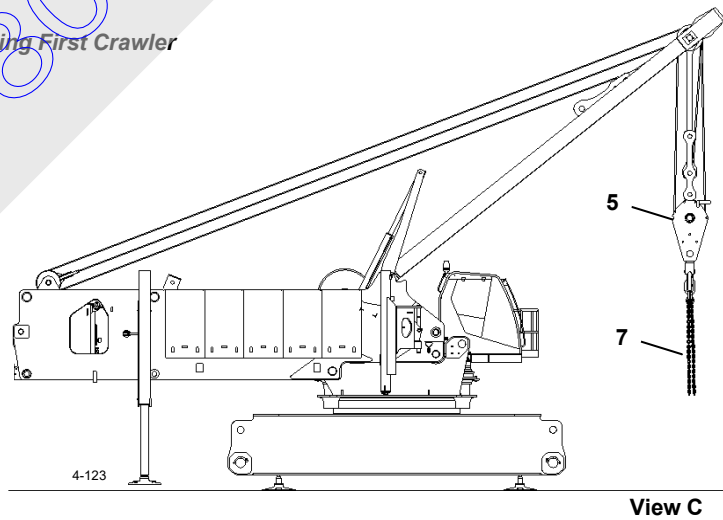
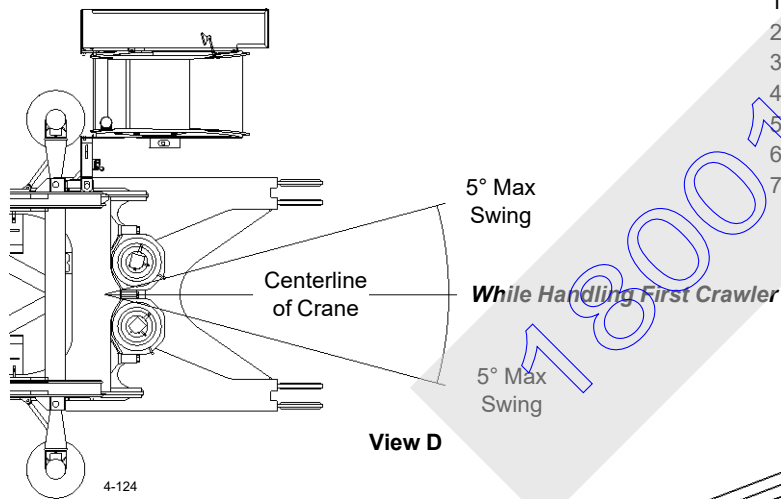

FIGURE 4-21

11. Proceed to use mast as a boom with mast hoist control for remainder of self-erect assembly procedure.

Use mast as a boom within 114-160° operating range (View C).

**NOTE** Mast will stop lowering and operating limit alert will come on, and MAST TOO FAR FWD will appear on the digital display if the mast is lowered to 160°.



### WARNING

#### Falling Mast Hazard!

Prevent mast from falling:

- Do not use limit bypass to lower mast below 160°. Mast will fall suddenly. **Connect an assist crane to end of live mast when it is necessary to lower it below 160°.**
- Do not lower mast assist arms until live mast is connected to fixed mast rigging. Mast will fall over backwards if raised to vertical when arms are down.

### Install Assembly Block

See [Figure 4-21](#) for the following procedure.



### WARNING

#### Falling Mast Hazard!

Prevent mast from falling:

- Do not use limit bypass to lower mast below 160° until **mast is supported with slings from assist crane.**

- Position trailer as shown in View A.
- MAST DOWN to lower mast (1) to approximately 160°.
- Attach nylon lifting slings (2, View A) from assist crane (3) to top end of mast.
- Lower mast to 180° with assist crane. *Do not side load mast.*

Use limit bypass switch to bypass mast limit and pay out wire rope from Drum 5 as mast is lowered with assist crane.

### CAUTION

#### Equipment Damage!

To prevent damage, guide mast straps (4) clear of trailer as required.

- Reeve wire rope from Drum 3 through sheaves in mast point and sheaves in assembly block (5, View B).
- Anchor wire rope to socket and wedge (6, View B) on load block (see Wire Rope Installation and Maintenance in this section).
- Connect 4-leg chain sling (7, View C) to assembly block.
- Raise mast to at least 160° with assist crane. As mast is raised:
  - Pay out wire rope from Drum 3.
  - Haul in wire rope on Drum 5.
- Haul in wire rope on Drum 3 to lift assembly block off trailer.
- Position mast in operating range (114°–160° mast angle) (View C).

### Install Crawlers

The crane must be in the following configuration to install crawlers:

- Mast arms fully raised.
- Crane setup mode selected and confirmed.
- Swing limited to 5° when handling first crawler ([Figure 4-21](#), View D).

Mast operated between 114° (mast arms fully extended) and approximately 150° (26 ft [7,9 m] radius) while lifting first crawler.

- Maximum capacity limited to 120,000 lb (54 430 kg).



### WARNING

#### Tipping Hazard!

- Do not exceed 120,000 lb (54 430 kg) capacity at 26 ft (7,9 m) radius when handling crawlers with mast. Crane will tip forward.
- Make sure crane is level. Adjust pedestals as required.

### CAUTION

#### Parts Damage!

Avoid hitting carbody pedestals with crawlers.



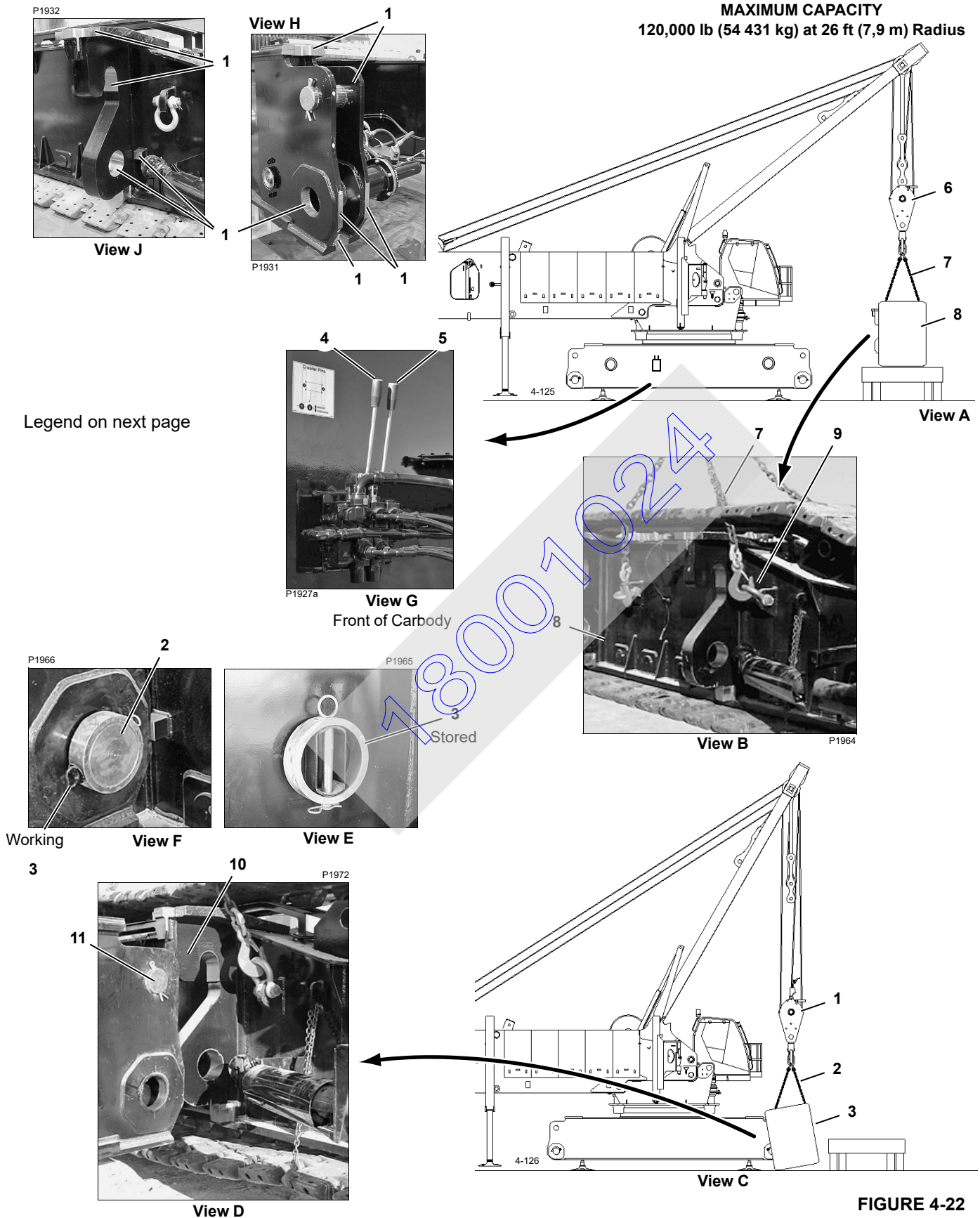

FIGURE 4-22



**Install First Crawler**

See [Figure 4-22](#) for the following procedure.

**NOTE** To prevent crawler pads from sagging too much when crawler is lifted, chains are installed between the crawler frames and pads (see [Figure 4-24](#), View F). Some sag must be allowed to prevent interference between carbody and crawler pads.

1. Position trailer carrying crawler along desired side of crane (View A).

**NOTE** Make sure crawler drive shaft is positioned at rear of carbody — end opposite crawler pins control (View G).

2. Thoroughly clean and grease all machined surfaces (1, Views H and J) on carbody and crawler.

**NOTE** Failure to clean and grease machined surfaces may result in loud banging sounds when attempting to turn crane. Though not harmful, operators may find sounds disturbing.

**NOTE** Crawler connecting pins (2, View F) are shipped from Manitowoc in retracted position. This is required to meet shipping width requirements.

Collars (3, View E) are stored on the carbody.

3. If not done, remove collars (3, View F) and retract crawler connecting pins (2) with crawler pins control (4 or 5, View G).

With crawler pins disengaged, grease them. See Section 5.

4. Attach hooks from chain sling (7, View B) to shackles on four crawler lifting lugs (9) — two legs with grab hooks to rear. Refer to Crawler Lifting Data decal ([Figure 4-23](#)).

5. Position chains between crawler pads.

6. Slowly hoist crawler clear of trailer. If necessary adjust length of rear chains so crawler lifts level.

**Crawler should be lifted as level as possible** — both front to rear and side to side. If crawler is not level, mating surfaces between crawler and carbody will not mate properly and installation will be difficult.

7. Remove trailer.
8. Slowly lower crawler, mast up, and swing to engage crawler hooks (10, View D) with carbody pins (11).
9. Stop lowering and masting down when crawler hooks are fully engaged with carbody pins and connecting holes are aligned (handling chains slack).
10. Using control handle (4 or 5, View G), engage crawler connecting pins (2, View F).
11. Install collars (3, View F), retaining pins, and hair-pin cotters.

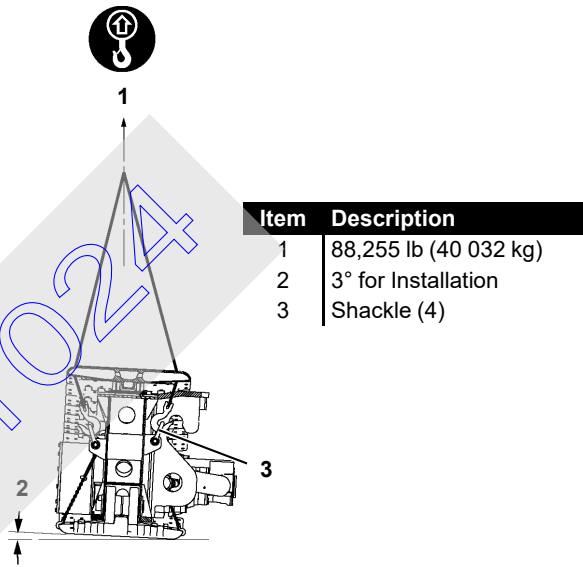

**WARNING**  
Crush Hazard!

- Use proper size rigging to lift as shown.

FIGURE 4-23

Legend for [Figure 4-22](#) (quantities are for one crawler)

Item	Description	Item	Description
1	Machined Surface	7	Chain Sling
2	Connecting Pin (2 places)	8	Crawler Assembly
3	Collar with Retaining Pin and Hair-Pin Cotter (2 places)	9	Lifting Lug with Shackle (4 places)
4	Right Crawler Pins Control	10	Crawler Hook (2 places)
5	Left Crawler Pins Control	11	Carbody Pin (2 places)
6	Assembly Block		

Legend on next page

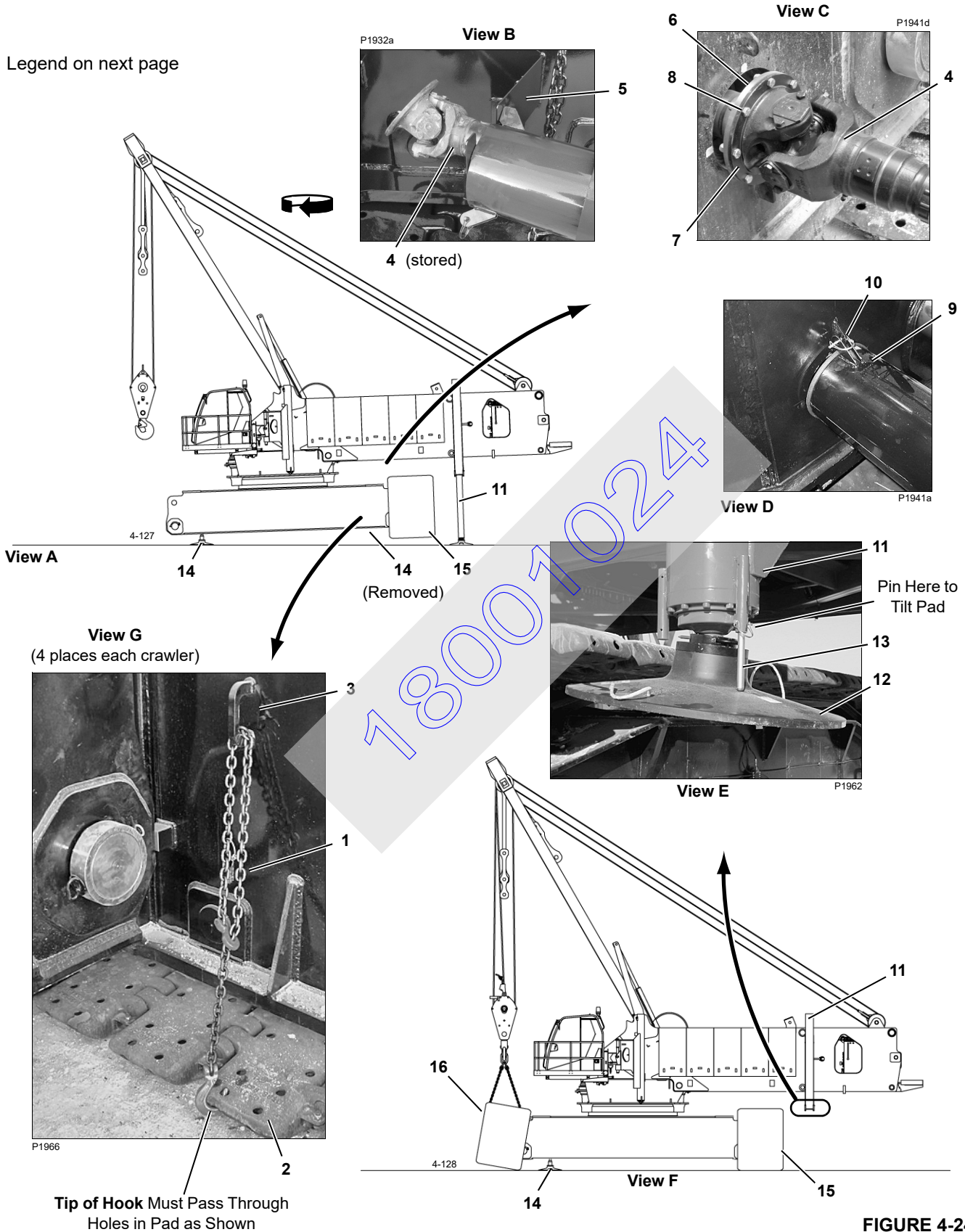

FIGURE 4-24

**Install First Crawler (continued)**

See [Figure 4-24](#) for the remaining steps.

- 12. Unhook chain sling from lugs on crawler frame.
- 13. Remove chains (1, View G) from between crawler pads (2) and crawler lugs (3) (four places). Store for future use.



**WARNING**

**Rotating Drive Shaft Hazard!**

Crawler drive shaft rotates at high speed.

- Make sure crawler drive shaft is securely attached at both ends.
- Make sure guards are in place and securely attached at both ends during operation.
- Do not attempt to service drive shaft until crane has been parked and engine stopped.

- 14. Lift crawler drive shaft (4, View B) off storage bracket (5), extend shaft, and align holes in drive shaft flanges (6 and 7, View C).
- 15. Insert flange bolts (8, View C) and locknuts. Torque to 35 ft-lb (48 Nm).
- 16. Slide drive shaft guard (9) over drive shaft and pin to carbody (View D).
- 17. Connect grease lines between carbody and crawler ([Figure 4-18](#), View D).
- 18. Retract rear jacks (11) until jack pads (12, View E) are about 2 ft (61 cm) off the ground.
- 19. Pin pad support rods (13, View E) in extended position to tilt jack pads at an angle.

**CAUTION**

Rear jack pads will strike crawler pads while swinging if step 19 is not performed.

- 20. Fully retract rear jacks and swing 180° (View A).  
**Swing slowly while watching rear jack pads as they approach crawler pads. If crawler pads are tight, it may be necessary to remove jack pads so they don't hit crawler pads.**
- 21. Extend rear rotating bed jacks (9, View E) until edge of tilted jack pad (12) just contacts ground.
- 22. Pin pad support rods (13, View E) in retracted position so jack pad hangs freely (parallel with ground). **Damage will occur if this step is not performed.**
- 23. Extend rear jacks (11) to lift crane off carbody pedestals next to first crawler (15, View A).
- 24. Remove pedestals (14) from next to first crawler.
- 25. Retract rear jacks (11) to lower crawler (15) to ground (View F).

**Install Second Crawler**

See [Figure 4-24](#) unless otherwise noted.

- 1. Repeat Install First Crawler steps 1 through 19 for second crawler.
- 2. Fully retract rear jacks and swing 180° so jacks are next to second crawler (16).
- 3. Extend rear rotating bed jacks (11, View E) until edge of tilted jack pad (12) just contacts the ground.
- 4. Pin pad support rod (13, View G) in retracted position so jack pad hangs freely (parallel with ground). **Damage will occur if this step is not performed.**
- 5. Extend rear jacks to lift crane off pedestals (14) next to second crawler (16).
- 6. Remove pedestals and store.
- 7. Retract jacks to lower crawler to ground.
- 8. Remove jack pads from rear jacks and store (see [Figure 4-7](#)).
- 9. Fully retract rear jacks and rotate to stored position ([Figure 4-13](#), View C).

**Legend for [Figure 4-24](#)**

Description	Item	Description
1 Chain with Hook	9	Drive Shaft Guard
2 Crawler Pad	10	Snap Pin
3 Crawler Lug	11	Rear Rotating Bed Jack
4 Crawler Drive Shaft	12	Jack Pad
5 Storage Bracket	13	Jack Pad Support Rod
6 Drive Shaft Flange (Carbody)	14	Carbody Pedestal
7 Drive Shaft Flange (Crawler)	15	Crawler Assembly (first installed)
8 Flange Bolt (8 each) with Locknut	16	Crawler Assembly (second installed)

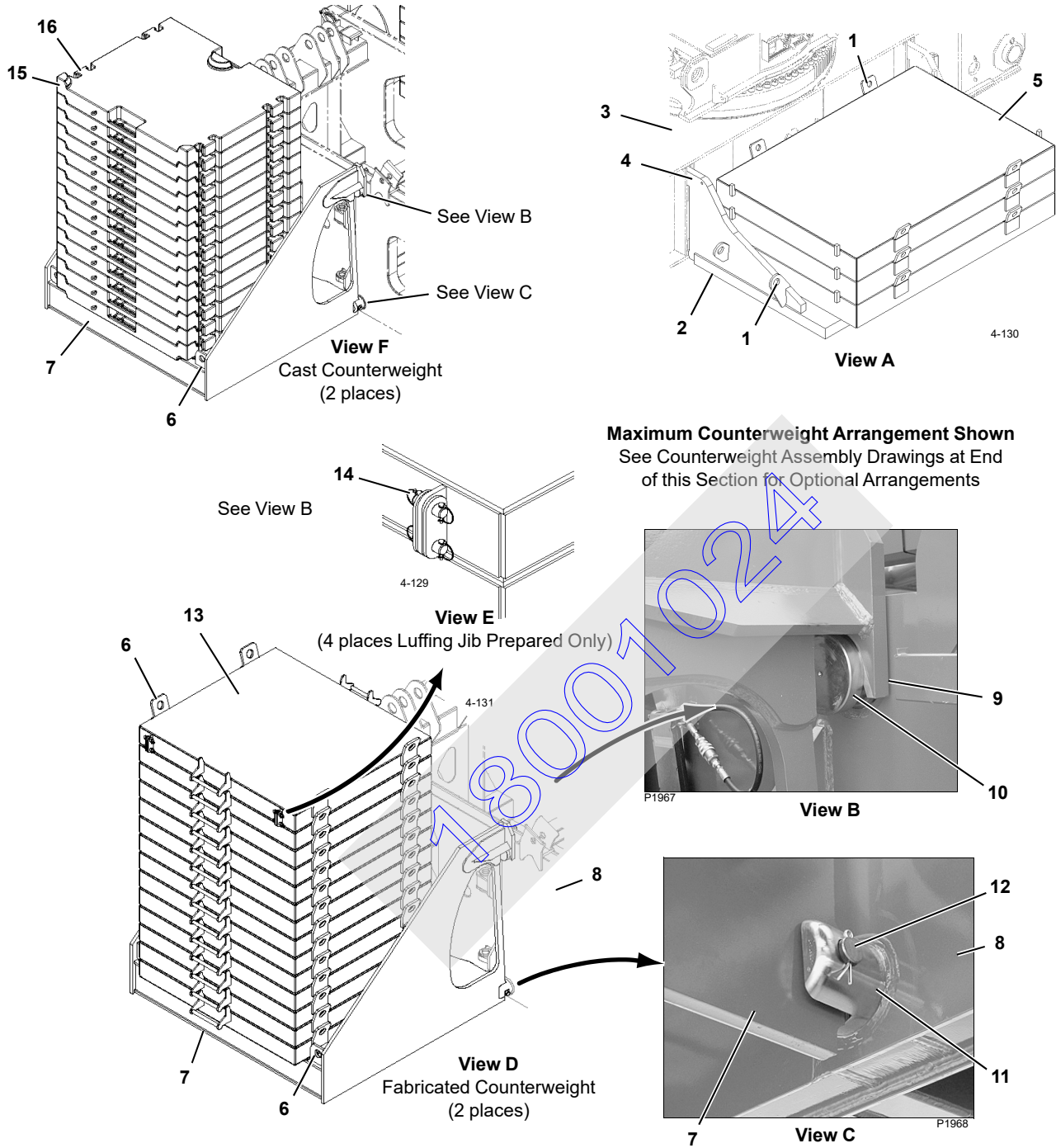

**Maximum Counterweight Arrangement Shown**  
See Counterweight Assembly Drawings at End of this Section for Optional Arrangements

Item	Description	Item	Description
1	Lifting Lug (4 places each tray and box)	9	Hook
2	Carbody Tray	10	Fixed Pin – Rotating Bed (2 places each side)
3	Carbody	11	Notched Pin – Rotating Bed (2 places each side)
4	Hooked Connector (not visible)	12	Retaining Pin with Snap Pins
5	Carbody Box (3 each end)	13	Fabricated Upperworks Box
6	Lifting Lug (4 each tray and box)	14	Links (stored for Luffing Jib only)
7	Upperworks Tray (1 each side)	15	Cast Counterweight Upperworks Box
8	Rotating Bed	16	Cast in Lug

FIGURE 4-25



## Install Counterweight

Refer to the Counterweight Assembly Drawings at the end of this section for the total number of carbody and upperworks boxes required for each counterweight arrangement. Counterweights may be fabricated or cast ([Figure 4-25](#), Views A, F).



### WARNING

#### Tipping Hazard!

To prevent crane from tipping:

- Install carbody counterweight before installing crane counterweight.
- Remove crane counterweight before removing carbody counterweight.

#### Falling Load Hazard!

To prevent counterweight from falling:

- Lifting lugs on individual components are intended to handle only that counterweight or component.

**NOTE** No counterweight — carbody or crane — is required to raise the fixed mast.

### Install Carbody Counterweight

See [Figure 4-25](#), View A for the following procedure.

The carbody counterweight can be installed with the live mast. The crane must be in the following configuration to install the carbody counterweight:

- Mast arms fully raised. Mast will be at approximately 107° (mast arms supporting mast) when attaching carbody counterweights.
  - Crane setup mode selected and confirmed.
  - 360° swing permitted while handling counterweight.
  - Live mast operated at radius no greater than 26 ft (7,9 m) (approximately 150°) while installing counterweight.
  - Capacity at maximum allowable radius limited to 120,000 (54 430 kg).
1. Attach legs of chain sling to lifting lugs (1, View A) on counterweight tray (2).
  2. Mast, swing, and hoist as necessary to position tray at desired end of carbody.
  3. Guide tray so hooked connectors (4) on tray engage lugs on carbody.
  4. Lower tray so that bottom of tray rests against carbody.
  5. Attach legs of chain sling to lifting lugs (1) on counterweight box (5).

6. Lower first box onto tray so it is centered between alignment lugs. *Lift only one box at a time.*  
Lifting lugs must face to front and rear of tray.
7. Position remaining two boxes (5), one at a time, on top of first box.  
Lifting lugs and side lugs will align boxes as they are installed.
8. Repeat steps 1–7 for carbody counterweight on opposite end.

### Install Crane Counterweight

The crane (upperworks) counterweight must be installed with an assist crane.

See [Figure 4-25](#), Views B, C, D and F for the following procedure.

1. Attach chain slings to lifting lugs (6, View D) on counterweight tray (7).

**NOTE** Inboard side of tray is cut out to prevent interference with rotating bed jack.

2. Boom, swing, and hoist as necessary to position tray at desired side of rotating bed (8).
3. Guide tray so top hooks (9, View B) engage fixed pins (10) in rotating bed.
4. Lower tray so tray engages notches in pins (11, View C) at bottom of tray and pin holes are aligned.
5. Install retaining pins (12, View C).
6. Remove chain sling.
7. Repeat steps 1–6 for tray on opposite side.
8. Attach lifting slings to lifting lugs (6, View D) or (16, View F) on counterweight box (13 or 15). Lift one box at a time.

**NOTE** For luffing jib prepared cranes, counterweight boxes with links (14, View E) must be installed on top of stack. These boxes are used for raising and lowering luffing jib struts.

9. Lower first box onto tray so it is centered between alignment lugs.  
Lifting lugs must face to front and rear of tray.
10. Remove lifting sling.
11. Repeat steps 8–10 for first counterweight box on opposite side.
12. Continue to install counterweight boxes, one at a time, alternating from side to side until required number of boxes is installed. Lifting lugs, steps, and cast pads will align boxes as they are installed.

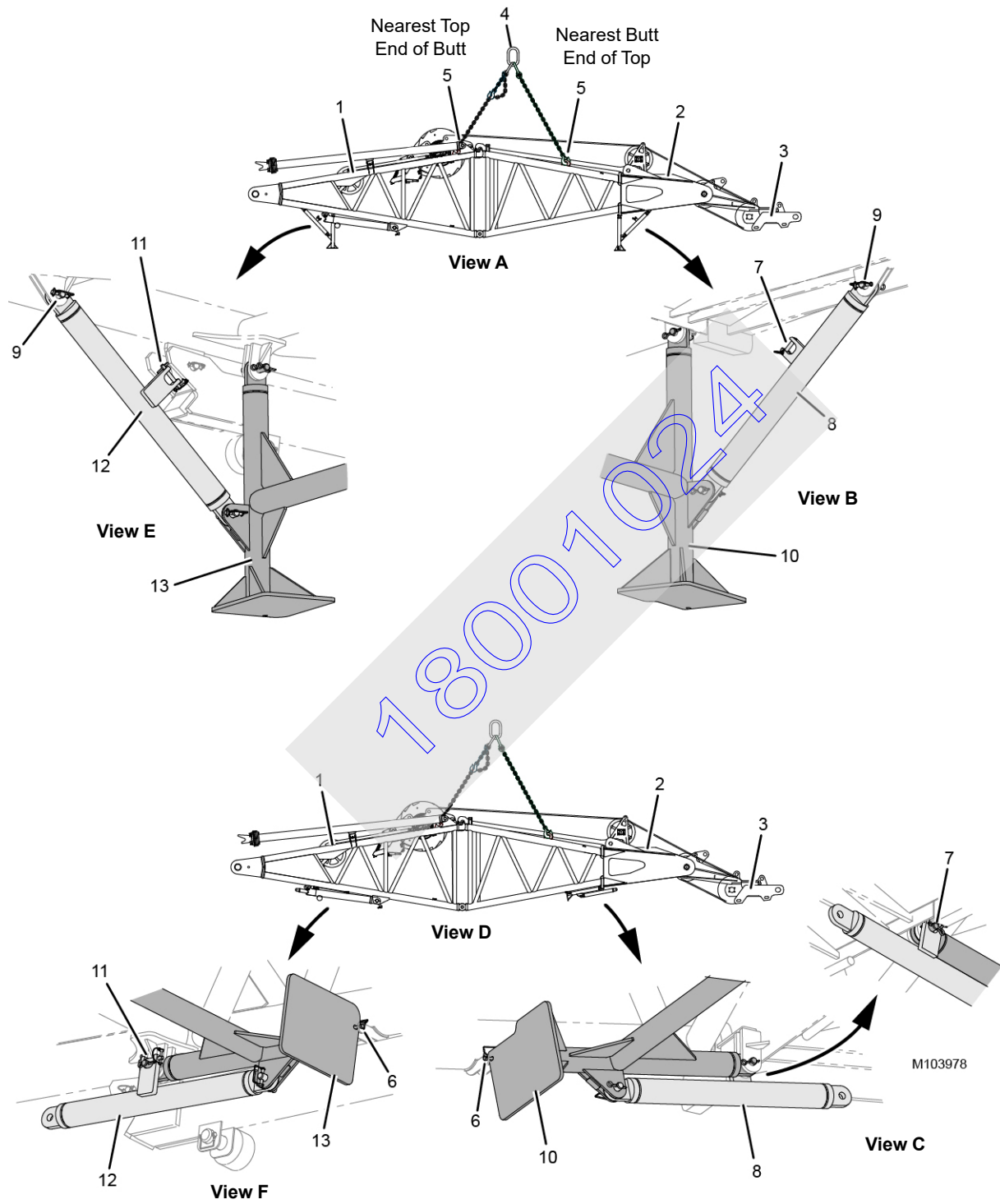

FIGURE 4-26

Legend for [Figure 4-26](#).

Item	Description
1	Mast Butt
2	Mast Top
3	Boom Hoist Equalizer
4	Chain Sling, 4-Leg with Grab Hooks *
5	Lifting Lugs (4 each section)
6	Safety Pin (4)
7	Pin with Safety Pin (2)
8	Strut (2)
9	Pin with Safety Pin (4)
10	Support
11	Pin with Safety Pin (2)
12	Strut (2)
13	Support

\* Same sling provided by Manitowoc for crawler handling.

## Stow Mast Supports

See [Figure 4-26](#) for the following procedure.

The mast butt (1), mast top (2), and boom hoist equalizer (3) are shipped assembled as shown in View A.

Crane Serial Number 18001113 and new newer are equipped with shipping/storage supports as shown in [Figure 4-26](#).

To stow the supports, proceed as follows:

1. Attach chain sling (4, View A) from the assist crane to lifting lugs (5) on mast butt (1) and mast top (2).  
**Grab hooks must be toward mast butt. Shorten both rear legs of sling by 13 links to provide proper lifting balance.**
2. Lift the mast assembly off the ground or trailer.
3. Remove the trailer.
4. Stow the mast top support as follows. Two people are required, one on each side of the mast top.
  - a. Remove safety pins (6, View C) from storage on mast top (2).
  - b. Remove pins (7, View B) from storage on struts (8).
  - c. Support struts (8, View B) so they cannot fall and remove pins (9).  
Each strut weighs 17 lb (8 kg).
  - d. Lower the struts slightly and reinstall pins (9, View B) in the lugs on the mast top.
  - e. Rotate support (10, View B) and struts (8) to the stowed position (View C).  
The support weighs 93 lb (42 kg).

- f. Install safety pins (6, View C) and pins (7) to connect the support and struts to the mast top.
5. Stow the mast butt support as follows. Two people are required, one on each side of the mast butt.
    - a. Remove safety pins (6, View F) from storage on mast butt (1).
    - b. Remove pins (11, View E) from storage on struts (12).
    - c. Support struts (12, View E) so they cannot fall and remove pins (9).  
Each strut weighs 17 lb (8 kg).
    - d. Lower the struts slightly and reinstall pins (9, View E) in the lugs on the mast butt.
    - e. Rotate support (13, View E) and struts (12) to the stowed position (View F).  
The support weighs 93 lb (42 kg).
    - f. Install safety pins (6, View F) and pins (11) to connect the support and struts to the mast butt.

## Deploy Mast Supports

Reverse the [Stow Mast Supports](#) procedure.



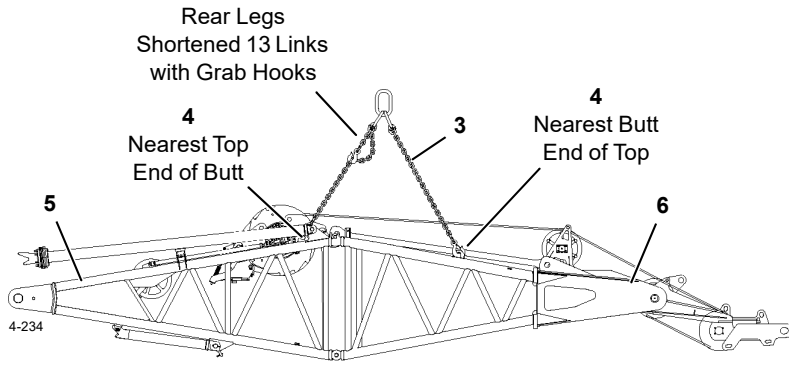

**View A**  
Mast Handling Arrangement

Item	Description
1	Keeper Plate with Snap Pins
2	Rotating Bed
3	Chain Sling, 4-Leg with Grab Hooks *
4	Lifting Lugs (4 each section)
5	Mast Butt
6	Mast Top
7	Mast Support
8	Pin with Snap Pins
9	Alignment Pin with Snap Pin
10	Mast Connecting Pin
11	Shoulder Screw (Current Production Only)

\* Same sling provided by Manitowoc for crawler handling.

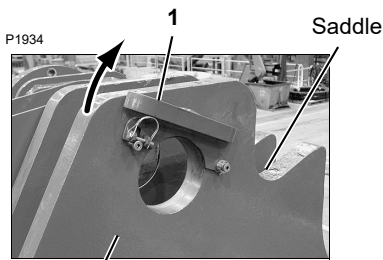

**View B**  
Past Production  
2 places  
Right-Hand Side  
Shown

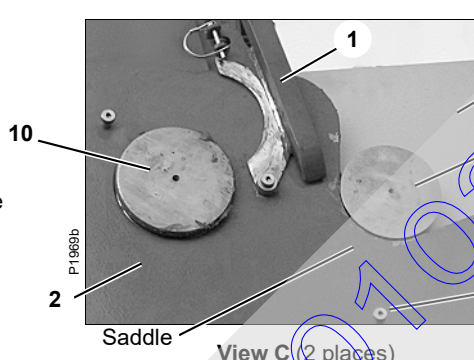

**View C** (2 places)

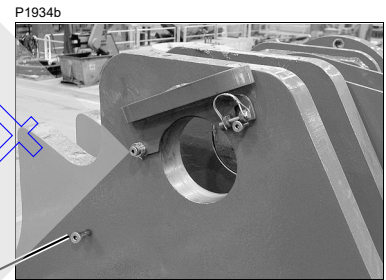

**View B**  
Current Production  
2 places  
Left-Hand Side  
Shown

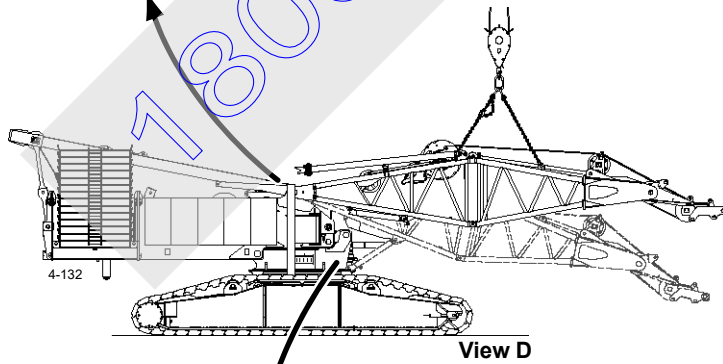

**View D**

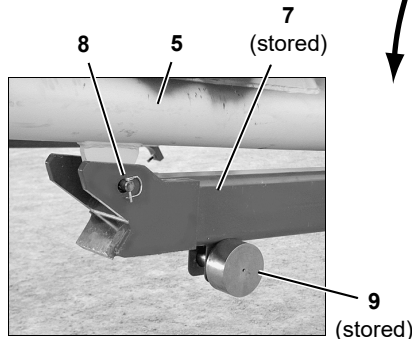

**View E**  
2 places

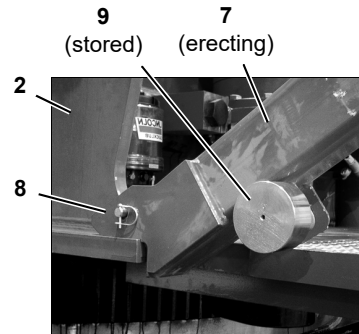

**View F**  
2 places

FIGURE 4-27

## Remove Assembly Block

Reverse steps under Install Assembly Block topic on [page 4-33](#).

## Assemble Fixed Mast

An assist crane is required to assemble and install the fixed mast.

### Install Mast Butt and Top

See [Figure 4-27](#) for the following procedure.

The mast butt, mast top, and boom hoist equalizer are shipped assembled as shown in View A.

1. Unpin keeper plates (1, View B) and rotate them out of the way (View C). On current production cranes, pin the keeper plate to the shoulder screw (11) to retain the keeper plate.
2. Using setup remote control, disengage mast connecting pins (10, View C). With pins disengaged grease them. See Section 5 of this manual.
3. Attach chain sling (3, View A) from assist crane to lifting lugs (4) on mast butt (5) and mast top (6).

**Grab hooks must be toward mast butt. Shorten both rear legs of sling by 13 links to provide proper lifting balance.**

4. Hold mast supports (7, View E) so they cannot drop, remove pins (8), and lower supports to erecting position. Each mast support weighs approximately 200 lb (91 kg).
5. Store pins (8) in lugs on mast butt.
6. Remove alignment pins (9, View E) from storage and install them in mast butt (View C).

7. Lift mast butt and top into position over saddles in rotating bed (View D).
8. Lower mast butt and top so alignment pins (9) rest in saddles in rotating bed (View C).
9. Raise or lower mast sections to align connecting holes in mast butt with holes in rotating bed.
10. Using setup remote control, engage mast connecting pins (10, View C).
11. Engage keepers (1) with grooves in connecting pins and install snap pins.
12. Remove alignment pins (9, View C) and store them on mast supports (View F).

**Do not support entire weight of mast butt and top on alignment pins. Damage may result.**

13. Lower mast butt and top until mast supports (7, View F) engage rotating bed and lifting slings slacken.
14. Disconnect lifting slings.
15. Uncouple hydraulic hoses for Drum 4 in mast butt and connect to couplers on rotating bed ([Figure 4-18](#), Views H and I).  
The quick couplers are arranged so the hoses can be connected only one way.

**NOTE** On current production cranes, hoses and corresponding couplers are tagged with numbers (see [Figure 4-18](#), View L). Match numbers to ensure proper hose connection.

16. Connect electric cables from Drum 4 to receptacles on rotating bed ([Figure 4-18](#), View K).

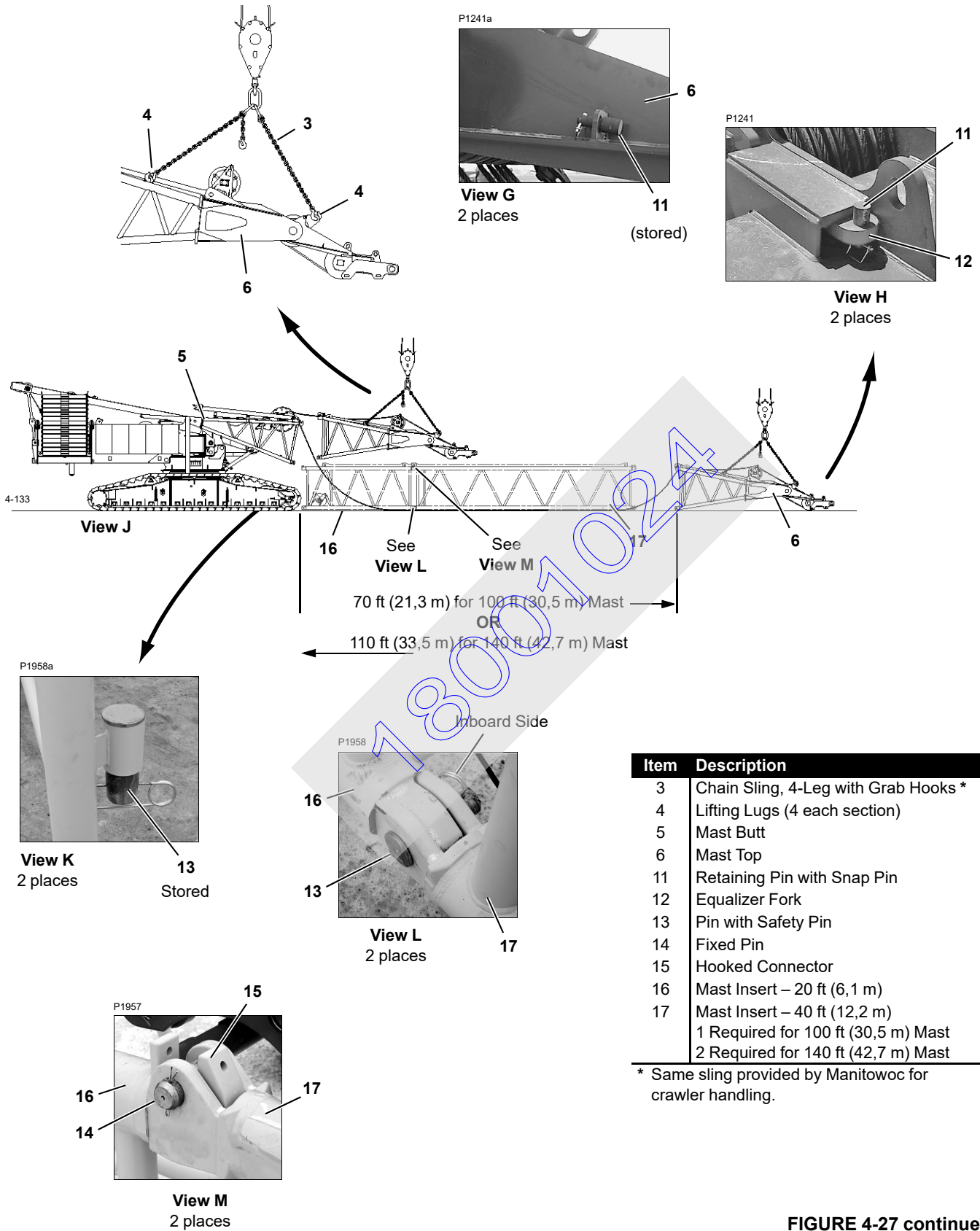

FIGURE 4-27 continued

See [Figure 4-27](#) for the remaining steps.

17. Check that retaining pins (11, View H) are installed in equalizer forks (12) so boom hoist equalizer cannot fall off forks when step 21 is performed.
18. Attach lifting slings (3, View J) from assist crane to lifting lugs (4) on mast top (6). Hoist so slings are just taut.
19. Remove pins (13, View L) and lift mast top clear of mast butt.
20. Pay out wire rope from Drum 4 in mast butt while performing step 21.
21. Lift mast top away from mast butt and place mast top on blocking in front of mast butt. Allow adequate space for assembling mast inserts as shown in View J.

### **Assemble Mast Inserts**

See [Figure 4-25](#) for the following procedure.

Four lifting lugs are located on top chords of both inserts (16 and 17). Use chain sling (3) to lift inserts.

1. Place insert (16) on blocking in front of mast butt.  
Blocking must be at least 8 in (203 mm) high.
2. Attach insert (17, View J) to insert (16):
  - a. Lift insert (17) into position so fixed pins (14, View M) in insert (17) engage hooked connectors (15) in insert (16).
  - b. Lower insert (17) to align bottom connecting holes and insert pins (13, View L).

**NOTE** On current production cranes, pins (13) are stored in tubes on insert (View K).

- c. Block under top end of insert (17).
- d. For 140 ft (42,7 m) mast, repeat steps 2a–2c to install second insert (17).

18001024

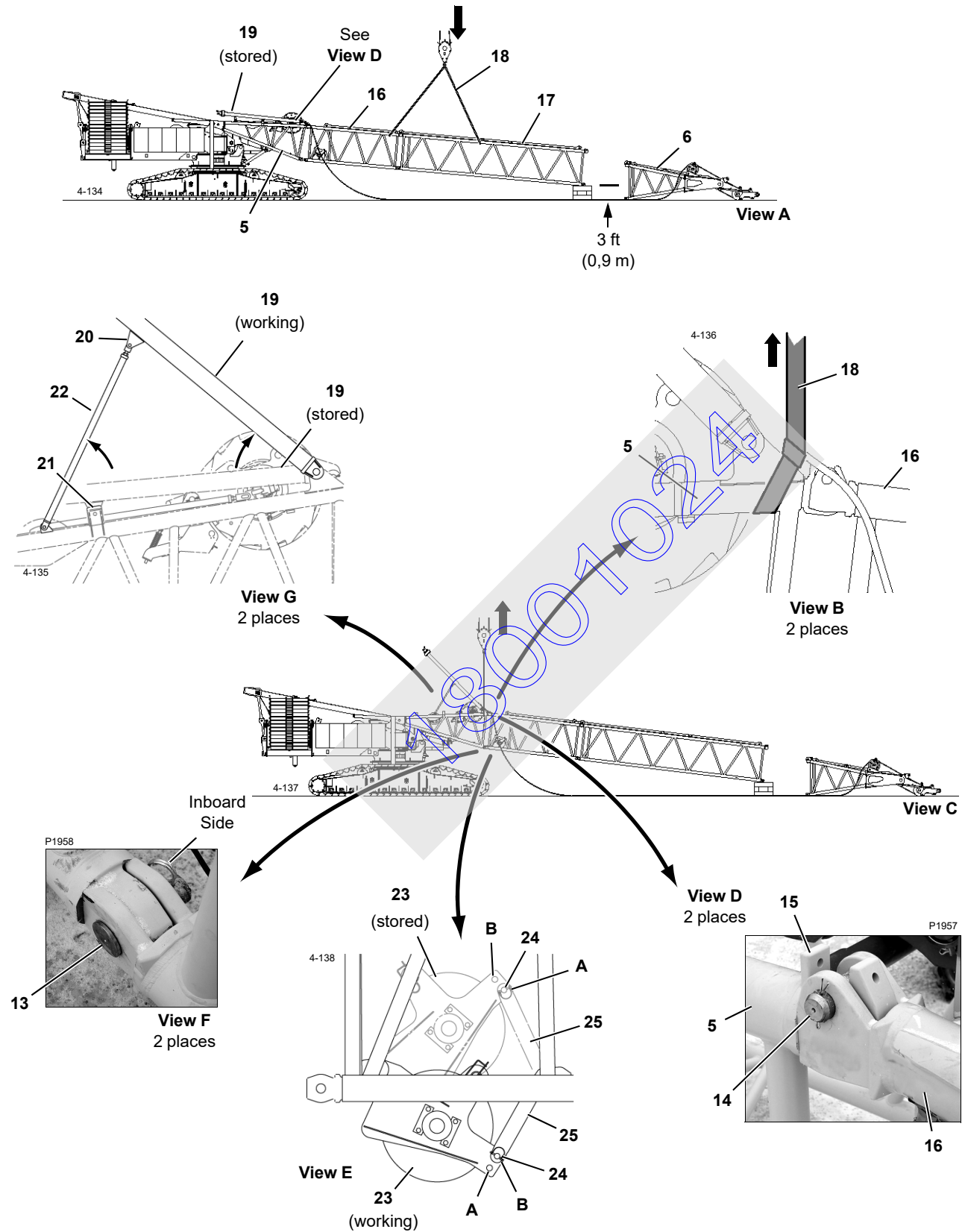

FIGURE 4-28

**Legend for Figure 4-28**

Item	Description
5	Mast Butt
6	Mast Top
13	Pin with Safety Pin
14	Fixed Pin
15	Hooked Connector
16	Mast Insert – 20 ft (6,1 m)
17	Mast Insert – 40 ft (12,2 m)
	1 Required for 100 ft (30,5 m) Mast
	2 Required for 140 ft (42,7 m) Mast
18	Nylon Lifting Slings (Owner Supplied)
19	Mast Stop
20	Pin with Cotter Pins
21	Shipping Bracket
22	Strut
23	Wire Rope Guide
24	Pin with Snap Pin
25	Link

**Connect Mast Inserts to Mast Butt**

See [Figure 4-28](#) for the following procedure.

1. Attach nylon lifting slings (18, View A) from assist crane to top chords of mast inserts (16 and 17).

**Lift against chords only — never lift against lacings.**

**Adjust slings so inserts lift level.**

2. Lift inserts into position so fixed pins (14, View D) in insert (16) engage hooked connectors (15) in mast butt (5).

**Do not install bottom pins.**

3. Place 3 ft (0,9 m) of blocking under top end of insert (17, View A).
4. Lower insert onto blocking and slacken lifting slings.
5. Disconnect lifting slings.
6. Attach nylon lifting slings (18, View B) to top chords at end of mast butt (5).

7. Lift mast butt and inserts to align bottom holes.
8. Insert pins (13, View F).
9. Slacken and disconnect lifting slings.

**NOTE** It is not necessary to store mast supports (7, [Figure 4-27](#), View F). The supports can be left in the working position and allowed to fold against the butt as the mast is raised.

**Raise Mast Stops**

See [Figure 4-28](#), View G for the following procedure.

Perform the following steps on both sides of mast butt.

1. Attach nylon lifting slings from assist crane to mast stop (19).
2. Remove pin (20) securing mast stop to storage bracket (21).
3. Raise mast stop to operating position.
4. Raise strut (22) to operating position and pin to mast stop with pin (20).

**Lower Wire Rope Guide**

See [Figure 4-28](#), View E for the following procedure.

Perform this procedure only if Drum 3 will be used for an additional load line.

1. Support wire rope guide (23) with nylon lifting slings attached to assist crane.
2. Remove pins (24), holding links (25), and wire rope guide (23) from stored position (holes A).
3. Lower wire rope guide (23) and links (25) to working position.
4. Pin links (25) to holes (B) in wire rope guide (23).
5. Run whip line from Drum 3 under guide sheave in butt and over guide in insert (see Load Line Reeving in this section).

Pull an additional 50 ft (15,2 m) whip line through wire rope guide and allow whip line to lie on ground off to side.



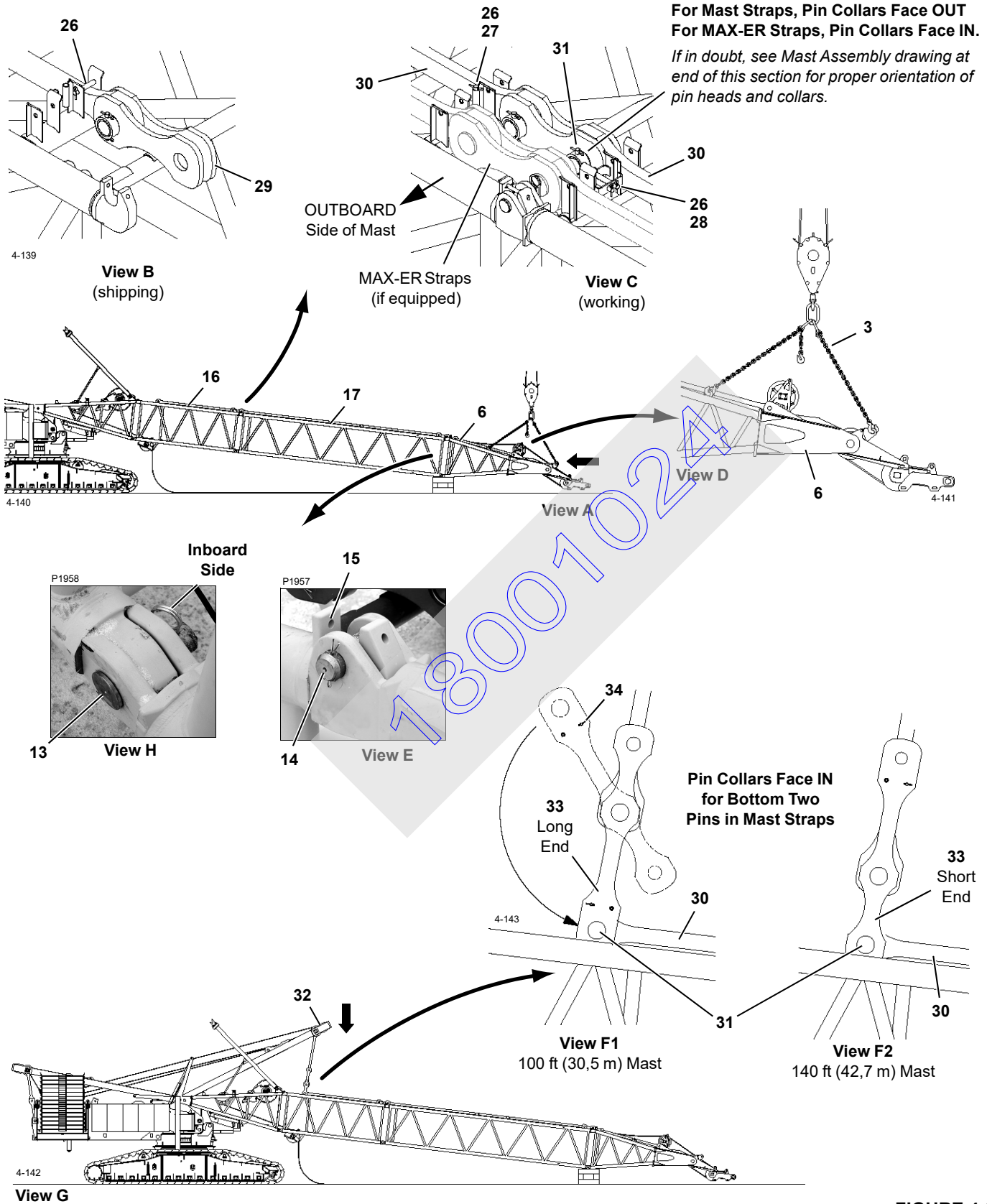

FIGURE 4-29



**Legend for Figure 4-29**

Item	Description
3	Chain Sling
6	Mast Top – 30 ft (9,1 m)
13	Pin with Safety Pin
14	Fixed Pin
15	Hooked Connector
16	Mast Insert – 40 ft (12,2 m)
17	Mast Insert – 20 ft (6,1 m)
26	Shipping Pin
27	Shipping Pin Storage Tube
28	Shipping Pin Storage Bracket
29	Links
30	Mast Strap
31	Pin with Collar, Retaining Pin, and Cotter Pins
32	Live Mast
33	Adjustable Link
34	Pin with Cotter Pins

**Attach Mast Top to Inserts**

See [Figure 4-29](#) for the following procedure.

1. Using chain slings (3) attached to lifting lugs on mast top (6, View D), lift mast top into position at insert (17, View A).
2. Engage fixed pins (14, View E) in mast top with hooked connectors (15) in insert.
3. Lower mast top to align bottom connecting holes between mast top and insert.
4. Install pins (13, View H).

**Connect Mast Straps**

See [Figure 4-29](#) for the following procedure.

Mast straps and links are shipped in the stored position on the fixed mast top and inserts as shown in View B. Connect straps as follows:

1. Remove all shipping pins (26, View B) and store them in tubes (27, View C) or brackets (28).
2. Attach links (29, View B) to straps (30, View C) with pins (31).

**NOTE** If your crane is prepared for a MAX-ER Attachment, the MAX-ER counterweight straps are stored in the outboard strap brackets on the mast top and inserts.

The counterweight straps do not have to be removed from the mast sections when operating without a MAX-ER attachment. **Counterweight straps must, however, be unpinned from strap brackets and pinned together in working position before raising mast** (like mast straps in View C).

To prevent counterweight straps from flopping around during operation, securely attach them to the mast straps.

**Connect Live Mast Straps to Fixed Mast Straps**

See [Figure 4-29](#) for the following procedure.

1. Lower live mast (32, View G) until adjustable links (33, View F1 or F2) are just above ends of straps (30) on insert.
2. For 100 ft (30,5 m) mast, remove retaining pins (34, View F1) and rotate adjustable links (33) so long end is down. Store retaining pins in links (33).  
For 140 ft (42,7 m) mast, leave long end of adjustable links (33) pinned to mast straps (View F2).
3. Lower live mast as required to align connecting holes and pin adjustable links (33) to straps (30) with pins (31).

**THIS PAGE INTENTIONALLY LEFT BLANK**

18001024

### Perform Mast Pre-Raising Checks

Perform the following pre-raising checks and correct any defects before raising mast.

- Crane on firm, level surface.
- Rotating bed jacks fully retracted and pinned in stored position.
- Rotating bed jack pads properly stored.
- Carbody pedestals properly stored.
- Mast hinge pins fully engaged.
- Mast inserts installed in proper sequence.
- Mast straps pinned in working position.
- If equipped, MAX-ER counterweight straps pinned in working position.
- All insert connector pins installed and properly retained.
- Setup mode selected and confirmed.
- Live mast arms fully lowered.
- All blocking, tools, and other items removed from mast.
- Mast and boom hoist wire rope spooled tightly onto drums and engaged with proper sheaves.
- Equalizer securely attached to proper size assist crane and positioned at proper distance from end of mast.
- Wind within allowable limits for operation.

### Raise Fixed Mast

**NOTE** No counterweight — carbody or crane — is required to raise the fixed mast. The counterweight can be installed, however.

#### General

To raise the mast, the SETUP mode must be selected to enable simultaneous operation of Drum 4 (boom hoist) and Drum 5 (mast hoist). The following controls are used to raise the mast:

- Drum 4 (boom hoist) on left console

- Drum 5 (mast hoist) on right console
- Drum park switches

A qualified operator is required to raise the mast. The operator shall be experienced with the 18000, and thoroughly familiar with its operation.

A qualified signal person is required to give signals to the operator(s).

A holdback is required to raise the fixed mast. Either the assembled crane boom or an assist crane can be used.

#### USING ASSEMBLED 18000 BOOM AS HOLDBACK

If the 18000 boom is used as the holdback, the following boom length is required:

**Table 4-3**  
Mast Holdback Requirements when Using 18000 Boom

Mast Length	Minimum Boom Length
100 ft (30,5 m)	120 ft (36,6 m)
140 ft (42,7 m)	140 ft (42,7 m)

#### USING ASSIST CRANE AS HOLDBACK

If an assist crane is used as the holdback, the assist crane must provide the holdback forces given in [Table 4-4](#). The letters in the table correspond to the letters in View A, [Figure 4-30](#).

**Table 4-4**  
Holdback Requirements when an Using Assist Crane

Mast Length	A	B	C
	From End of Crawler	Horizontal	Vertical
100 ft (30,5 m)	110 ft (33,5 m)	35,000 lbf (156 kN)	27,000 lbf (120 kN)
140 ft (42,7 m)	(see Note)		

**NOTE** For 140 ft (42,7 m) mast, assist crane and equalizer must be traveled to dimension A once mast is out of the way.

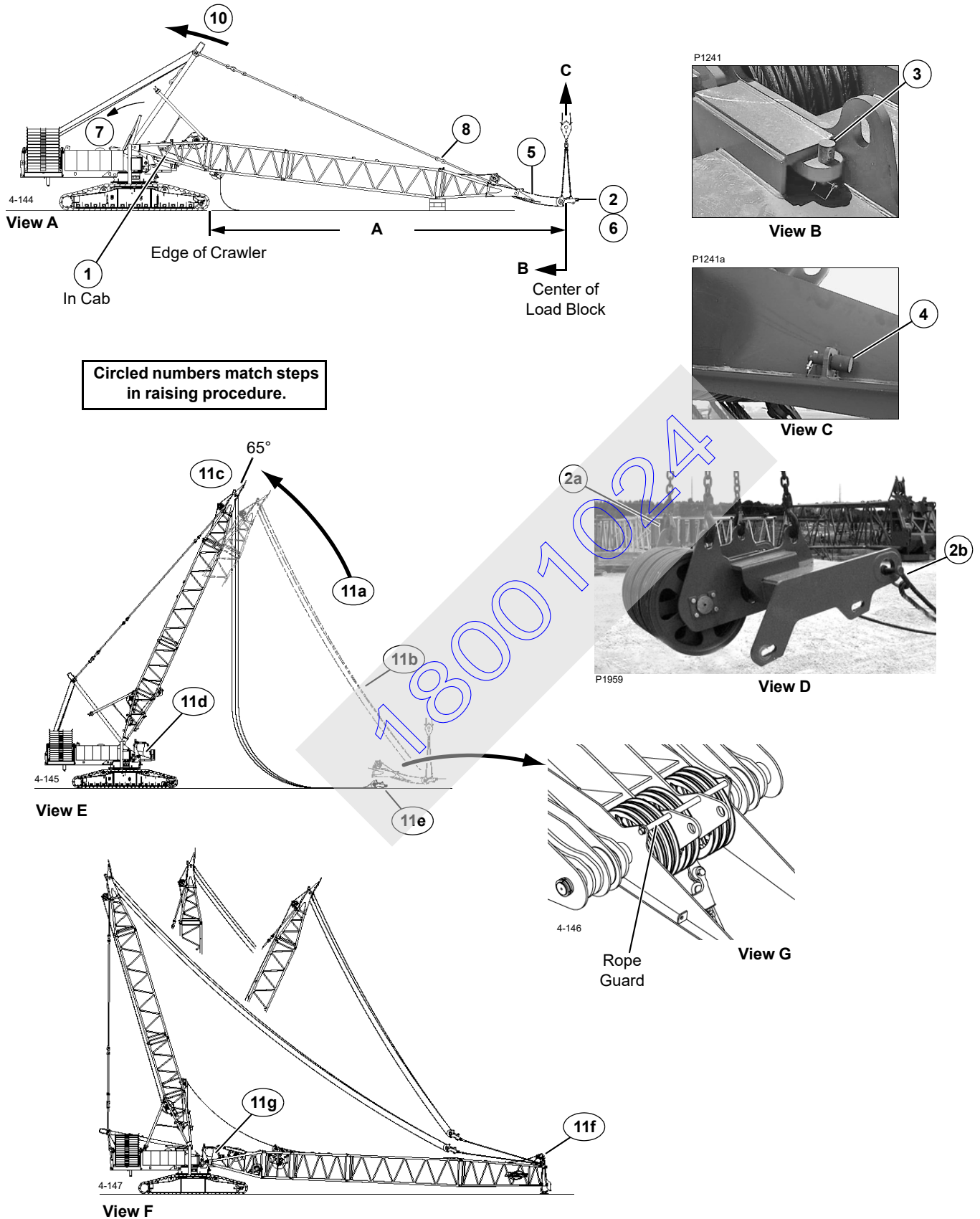

FIGURE 4-30

**Raise Mast**

Circled numbers in [Figure 4-30](#) match the following steps.

1. Start crane engine and select/confirm SETUP mode.
2. Attach assist crane to boom hoist equalizer (View D):
  - a. Attach 4-leg chain sling to lifting holes in equalizer.
  - b. Securely attach wire rope slings between equalizer and rotating bed or carbody of assist crane.

**CAUTION****Wire Rope Damage!**

Boom hoist equalizer will tip if it is not properly supported, possibly resulting in damage to wire rope. Support boom hoist equalizer properly during mast raising.

3. Remove boom hoist equalizer retaining pins (View B) from mast top forks.
4. Store equalizer retaining pins (View C) in mast top lugs (View C).
5. Lift boom hoist equalizer and pull equalizer off forks on end of mast. Pay out boom hoist wire rope as required.
6. Park assist crane so equalizer is at Dimension A from end of crawlers (see View A, and [Table 4-4](#)). **Equalizer must be centered with relation to mast to prevent side loading mast.**  
**Assist crane must provide specified holdback forces (B and C, View A and [Table 4-4](#)).**
7. Using remote control, fully lower live mast arms.

**WARNING****Mast Damage!**

Lower live mast arms before raising fixed mast. Mast can collapse if arms are up when live mast is lowered.

8. Verify that all mast strap shipping pins are removed and stored ([Figure 4-29](#), View C).

**CAUTION****Mast Damage!**

Avoid mast or equalizer damage. Do not proceed to raise mast until fixed mast straps are unpinned from strap brackets.

9. Perform mast pre-raising steps before continuing.
10. Slowly haul in mast hoist wire rope to raise mast until straps are taut.
11. If boom will be used as a holdback, proceed as follows. Otherwise, go to step 12.
  - a. Haul in mast hoist wire rope and pay out boom hoist wire rope to raise mast.
  - b. Keep boom hoist rope as slack as possible **to prevent boom hoist wire rope from bearing against rope guard in mast top (View G).**
  - c. Do not raise mast any higher than 65°. When fixed mast is at 65°, live mast will be at approximately 53°. The live mast angle can be monitored on the display in the cab.
  - d. Turn on drum park for Drums 4 and 5.
  - e. Place boom hoist equalizer on ground to side of boom assembly area and disconnect assist crane.  
**Take every precaution to protect wire rope from damage.**  
**Do not allow wire rope to jump off sheaves (in mast and equalizer) or otherwise become fouled.**
  - f. Refer to Boom Installation in this manual and completely install desired length of boom and jib, if equipped.
  - g. Turn off drum park for Drums 4 and 5 and go to step 12.

**WARNING****Mast Damage!**

Mast raising cylinders must be lowered using set-up remote before lifting loads with fixed mast.

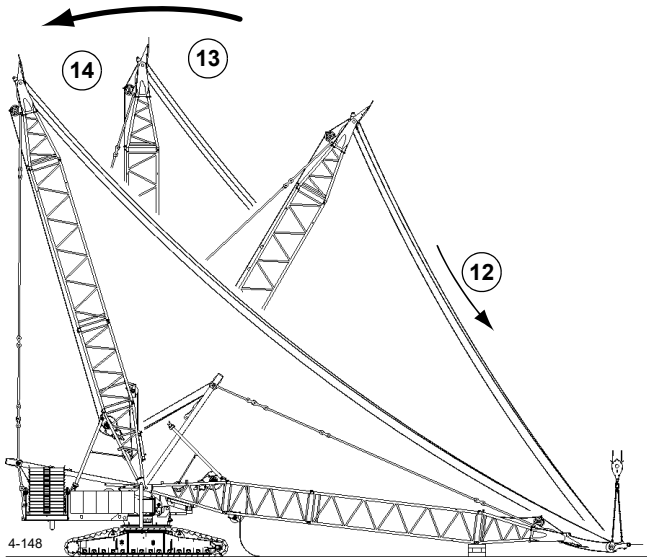

View H

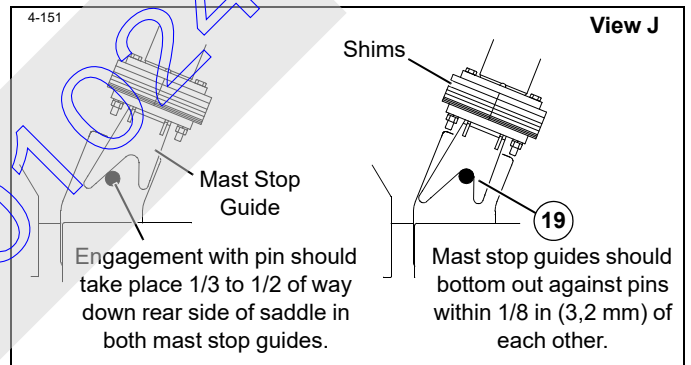

View J

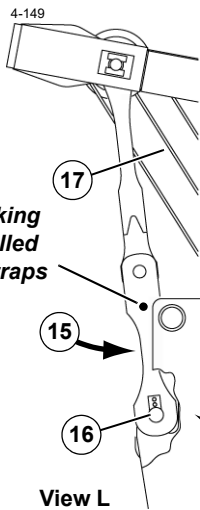

**Note that Locking Pins are Installed in Live Mast Straps**

View L

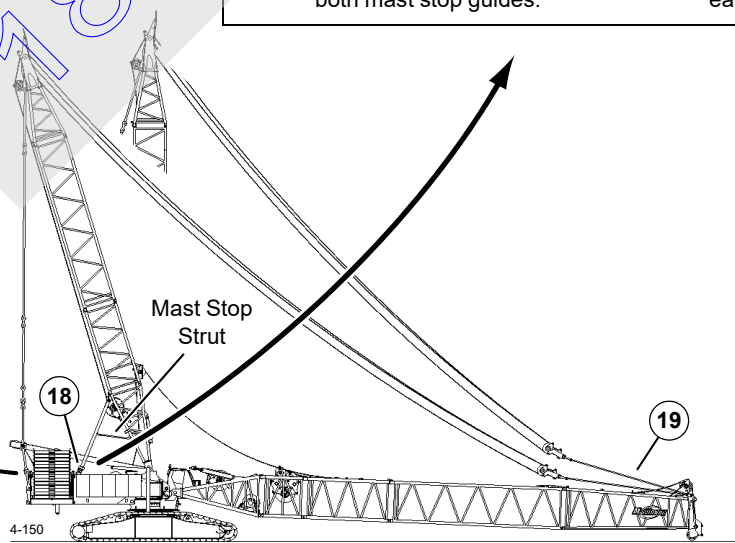

View K

FIGURE 4-30 continued

12. Continue to raise live mast while paying out boom hoist wire rope.

Keep boom hoist rope as slack as possible **to prevent boom hoist wire rope from bearing against rope guard in mast top (View G).**

**NOTE** Operator shall match rate of speed at which mast hoist wire rope is hauled in with rate of speed at which boom hoist wire rope is payed out. **Boom hoist wire rope must remain slack until mast nears vertical.**

13. As mast nears vertical, tighten boom hoist wire rope as required so mast moves smoothly past vertical to rear.
14. Continue to slowly haul in mast hoist wire rope and pay out boom hoist wire rope to lower mast to rear.
15. As mast lowers, guide live mast straps into position at rear of rotating bed (View L). **Do not allow links to contact hand rails on rear of crane.**
16. Stop lowering mast when holes in live mast straps line up with holes in rear of rotating bed. Connect straps to rotating bed with pins and keeper plates provided (View L).

**NOTE** Reference the live mast assembly drawing for correct pin assembly configuration. Options include standard pin configuration, MAX-ER configuration with backhitch load pin, and shipping configuration with MAX-ER backhitch load pin.

17. Pay out mast hoist wire rope until it starts to go slack. **Mast hoist wire rope must not go into tension during crane operation.**
18. Pay out boom hoist wire rope until mast stop guides bottom out against mast stop pins (View J).

If necessary, adjust guides as follows (see View J):

- Adjust slotted rod ends on mast stop struts so engagement with pins takes place 1/3 to 1/2 of way down rear side of saddle in both boom stop guides.
- Adjust shims so boom stop guides bottom out against pins within 1/8 in (3,2 mm) of each other.

19. If not already done, install boom and jib.

### Check Mast Stop Pressure

If your crane is prepared for a MAX-ER attachment, each mast stop has a hydraulic pressure gauge (Figure 4-31).

Check both gauges WEEKLY. The gauges should read 200-280 psi (13,8 - 19,3 bar) depending on outside air temperature. If the proper reading is not indicated at either gauge, determine cause of faulty pressure and take corrective action.



### WARNING

#### Explosion Hazard!

Mast stop cylinders are equipped with nitrogen pre-charged accumulators.

Do not tamper with accumulators unless authorized and trained to do so.

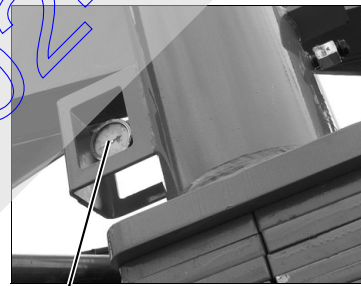

P2086

Hydraulic Pressure Gauge  
at Base of Both Mast Stops

FIGURE 4-31

### Assemble and Install Boom and Jib

If not already done, assemble and install the desired boom and jib combination. See Boom and Jib Rigging instructions in this section and Boom and Jib Rigging drawings at the end of this section.

If a luffing jib will be installed, see separate instructions in Luffing Jib Operator Manual.



## PRE-RAISING CHECKS

Perform the following pre-raising checks and correct any defects before raising boom or boom and jib.

- Crane on firm, level surface.
- Crawlers blocked if required per Capacity Chart.
- All connecting pins installed and properly retained.
- Boom and jib inserts installed in the proper sequence.
- Boom, jib, and backstay straps installed in the proper sequence and unpinned from storage positions.
- All jib backstay straps, links, and pins removed from boom sections (if jib will not be used).
- All insert and strap connecting pins installed and properly retained.
- Lower boom point removed if required per Capacity Chart.
- All blocking, tools, and other items removed from boom.
- Electronic boom angle indicator properly installed and adjusted.
- Block-up limit control properly installed and operational.
- Rated Capacity Indicator/Limiter properly installed and operational.
- Automatic boom stop properly installed. Must be adjusted after boom is raised.
- Physical boom stop operating properly.
- Crane and attachment properly lubricated.
- Jib strut raised and strut stops pinned in operating position.
- Load lines anchored properly to drums, spooled tightly onto drums, and engaged with proper sheaves. Make sure rope guard pins, bars, or rollers are installed to retain wire rope on sheaves.
- Load lines securely anchored to sockets at boom points or at load block and weight ball.
- All safety devices installed, electric cords connected, and limits adjusted.
- Proper amount of crane counterweight and, if required, MAX-ER counterweight installed.
- Wind within allowable limits for raising boom or boom and jib.

18001024

## RAISING BOOM AND JIB

See [Figure 4-32](#) for the following procedure.

1. Read and adhere to raising and lowering limitations given in Liftcrane Fixed Jib Capacities Chart.
2. Raise boom until lower jib point is just clear of blocking.

**NOTE** For long boom-short jib combinations, weight of backstay straps may prevent the jib from rotating down to its proper operating position when boom is raised. If this happens, you will not be able to pin jib stop locking pins in step 3. Take the following corrective action:

- Attach slings from assist crane to straps midway between points shown in [Figure 4-32](#).
  - Hoist with assist crane until jib rotates down to its proper operating position.
3. Adjust jib stops:
    - a. Remove jib stop locking pin (5, View B).

- b. Turn each adjusting rod (4, View C) until appropriate holes for desired jib offset are aligned (View B).

- Hole A for 5° offset
- Hole B for 20° offset

If it is difficult to turn adjusting rod (4), lift strut stop at location (6) shown in View B

- c. Insert jib stop locking pins (5) in appropriate hole for jib offset.
  - d. If necessary, disconnect assist crane from backstay straps.
4. Pin upper jib point to jib top:
    - a. Slowly continue to boom up until lower connecting holes in jib top and upper point (7) are aligned (View A).
    - b. Insert pins (8). Retain with cotter pins.
  5. Continue to raise boom and jib to desired operating position.

18001024

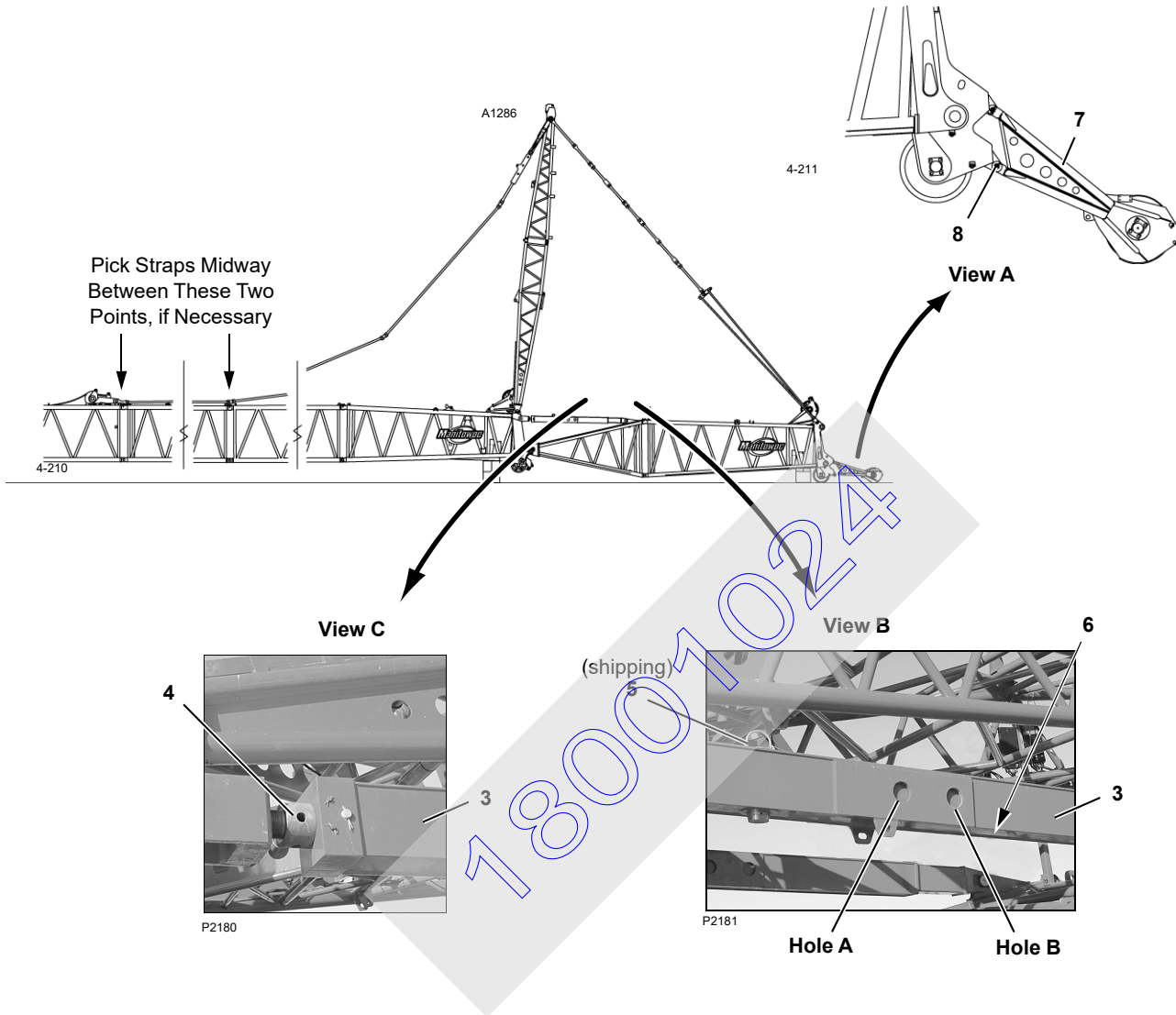

Item	Description
1	#55 Boom Top
2	#49 Jib
3	Jib Stop
4	Adjusting Rod
5	Jib Stop Locking Pin
6	Jib Stop Luffing Location
7	Upper Jib Point
8	Connecting Pin w/ Cotter Pins (2 places)

FIGURE 4-32

## CRANE DISASSEMBLY

### Lowering Boom And Jib

See [Figure 4-32](#) for the following procedure.

1. Swing boom and jib slightly to either side of center and lower load block or weight ball onto ground. Then swing boom and jib to desired position with relation to crawlers and apply swing brake.

**Read and adhere to raising and lowering limitations given in Liftcrane Fixed Jib Capacities Chart.**

2. When equipped with an extended upper boom point, the roller path must be a firm, level surface and clear of obstructions. The extended upper boom point rollers must travel freely and unrestrained on a solid and impervious surface while boom is being lowered to the ground.
3. Lower boom and jib until upper point (7, View A), if equipped, just contacts ground.
4. Remove lower pins (8, View A).
5. Continue lowering boom until jib is almost on blocking.

**NOTE** For long boom-short jib combinations, weight of backstay straps may prevent the jib from rotating down to its proper operating position when boom is lowered. If this happens, jib stop locking pins will be tight and difficult to remove in step 5. Take the following corrective action:

- Attach slings from assist crane to straps midway between points shown in [Figure 4-32](#).
- Hoist with assist crane until jib rotates down to its proper operating position.

6. Remove jib stop locking pins (5, View B) from Holes A or B and store in shipping position as shown in View B.
7. Lower boom and jib onto blocking.
8. If necessary, disconnect assist crane from backstay straps.

### Lower Fixed Mast

**NOTE** No counterweight — carbody or crane — is required to raise the fixed mast. The counterweight can be installed, however.

### General

To raise the mast, the SETUP mode must be selected to enable simultaneous operation of Drum 4 (boom hoist) and Drum 5 (mast hoist). The following controls are used to raise the mast:

- Drum 4 (boom hoist) on left console
- Drum 5 (mast hoist) on right console
- Drum park switches

To operate Drums 4 and 5 simultaneously during crane disassembly, the SETUP mode must be selected and confirmed.

To operate the setup remote control during crane disassembly, the SETUP REMOTE must be selected and confirmed.

A qualified operator is required to raise the mast. The operator shall be experienced with the 18000 and thoroughly familiar with its operation.

A qualified signal person is required to give signals to the operator(s).

A holdback is required to raise the fixed mast. Either the assembled 18000 boom or an assist crane can be used.

### Using Assembled 18000 Boom as Holdback

If the 18000 boom is used as the holdback, see [Table 4-3](#) for boom length requirements.

### Using Assist Crane as Holdback

If an assist crane is used as the holdback, the assist crane must provide the holdback forces given in [Table 4-4](#). The letters in the table correspond to the letters in View C, [Figure 4-33](#).

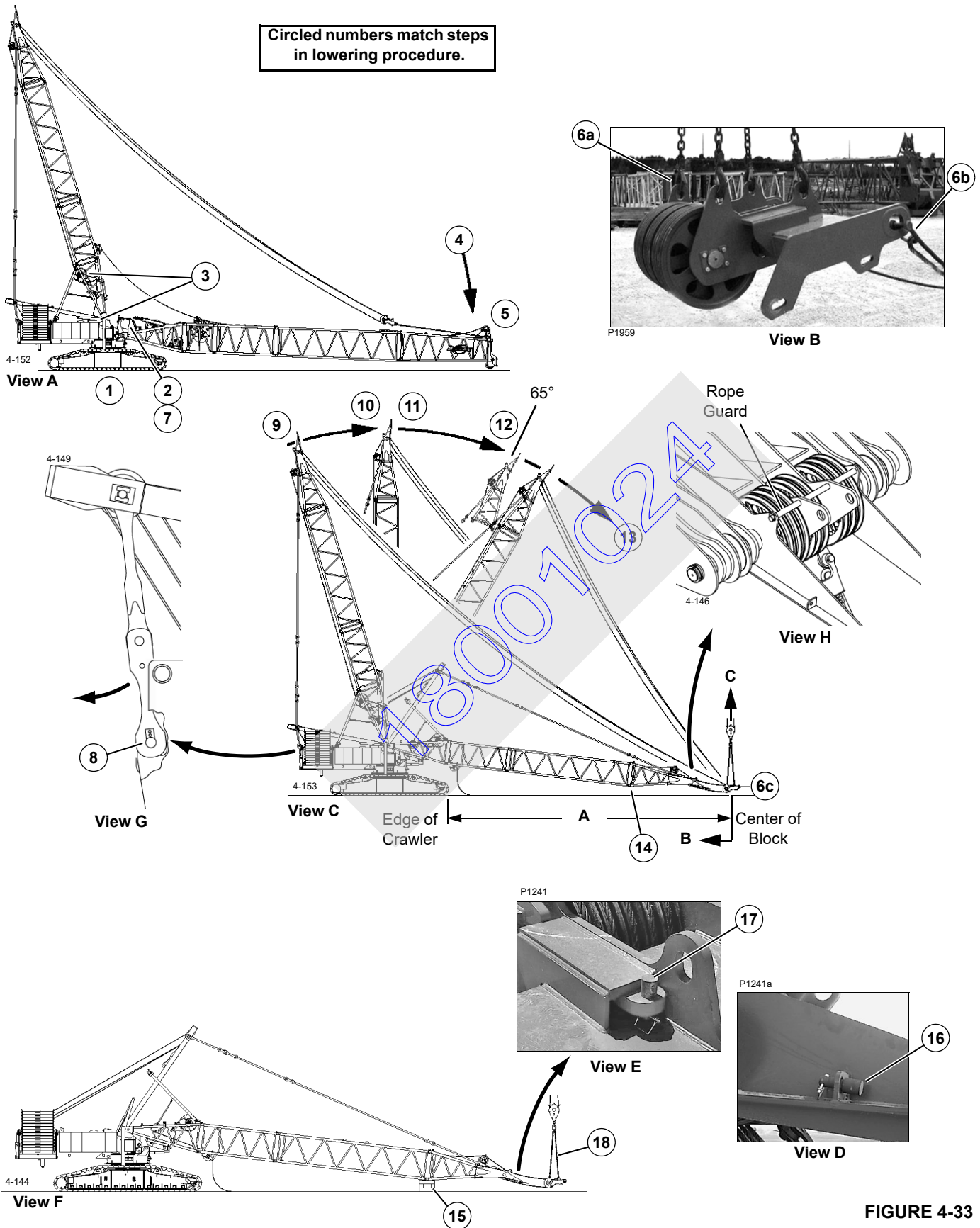

FIGURE 4-33

## Lower Mast

Circled numbers in [Figure 4-33](#) match the following steps.

1. Position crane on a firm, level surface.
2. Start crane engine and select/confirm SETUP mode.
3. Make sure mast hoist and boom hoist wire rope is spooled properly onto drums.
4. Lower boom to ground.
5. If an assist crane will be used as the holdback, remove boom from crane.
6. If an assist crane will be used as the holdback, attach assist crane to boom hoist equalizer (View B):
  - a. Attach 4-leg chain sling to lifting holes in equalizer.
  - b. Securely attach wire rope slings between equalizer and rotating bed or carbody of assist crane.

### CAUTION

#### Wire Rope Damage!

Boom hoist equalizer will tip if it is not properly supported, possibly resulting in damage to wire rope. Support boom hoist equalizer properly while lowering mast.

- c. Park assist crane so equalizer is at Dimension A from end of crawlers (see View C, and [Table 4-4](#)). **Equalizer must be centered with relation to mast to prevent side loading mast.**  
**Assist crane must provide specified holdback forces (B and C, View C and [Table 4-4](#)).**
7. Select SETUP mode and confirm.



### WARNING

#### Moving Equipment!

Mast straps will swing away from rotating bed when unpinned. Stand to side when removing pins. Do not allow links to contact hand rails on rear of crane.

8. Unpin live mast straps from rear of rotating bed (View G). If necessary, boom up slightly to remove loading on pins. Store pins and keeper plates with straps.
9. Slowly haul in boom hoist wire rope and pay out mast hoist wire rope to raise mast toward vertical.

10. As mast nears vertical, tighten mast hoist wire rope as required so mast moves smoothly forward past vertical.
11. Continue to lower live mast by slowly paying out mast hoist wire rope and hauling in boom hoist wire rope.

Keep boom hoist rope as slack as possible **to prevent boom hoist wire rope from bearing against rope guard in mast top (View H).**

12. If boom is being used as the holdback, proceed as follows:
  - a. Stop lowering mast when it is at 65°.
 

When fixed mast is at 65°, live mast will be at approximately 53°. The live mast angle can be monitored on the display in the cab.
  - b. Turn on drum park for Drums 4 and 5.
  - c. Place boom hoist equalizer on ground to side of boom assembly area and disconnect assist crane.

**Take every precaution to protect wire rope from damage.**

**Do not allow wire rope to jump off sheaves (in mast and equalizer) or otherwise become fouled.**

- d. Completely remove jib and boom.
- e. Perform steps 6a through 6c.
13. Continue to lower live mast by slowly paying out mast hoist wire rope and hauling in boom hoist wire rope.

**NOTE** Operator shall match rate of speed at which boom hoist wire rope is hauled in with rate of speed at which mast hoist wire rope is payed out.

14. Stop lowering mast when bottom connectors between 40 ft (12,2 m) mast insert and mast top are approximately 3-1/2 ft (1,1 m) off ground.
15. Install blocking under top end of 40 ft (12,2 m) insert (View F). Lower mast onto blocking.
16. Remove boom hoist equalizer retaining pins from mast top lugs (View D).
17. Using assist crane, lift boom hoist equalizer into position on forks at end of mast top (View E) and install retaining pins.
18. Disconnect assist crane from equalizer.



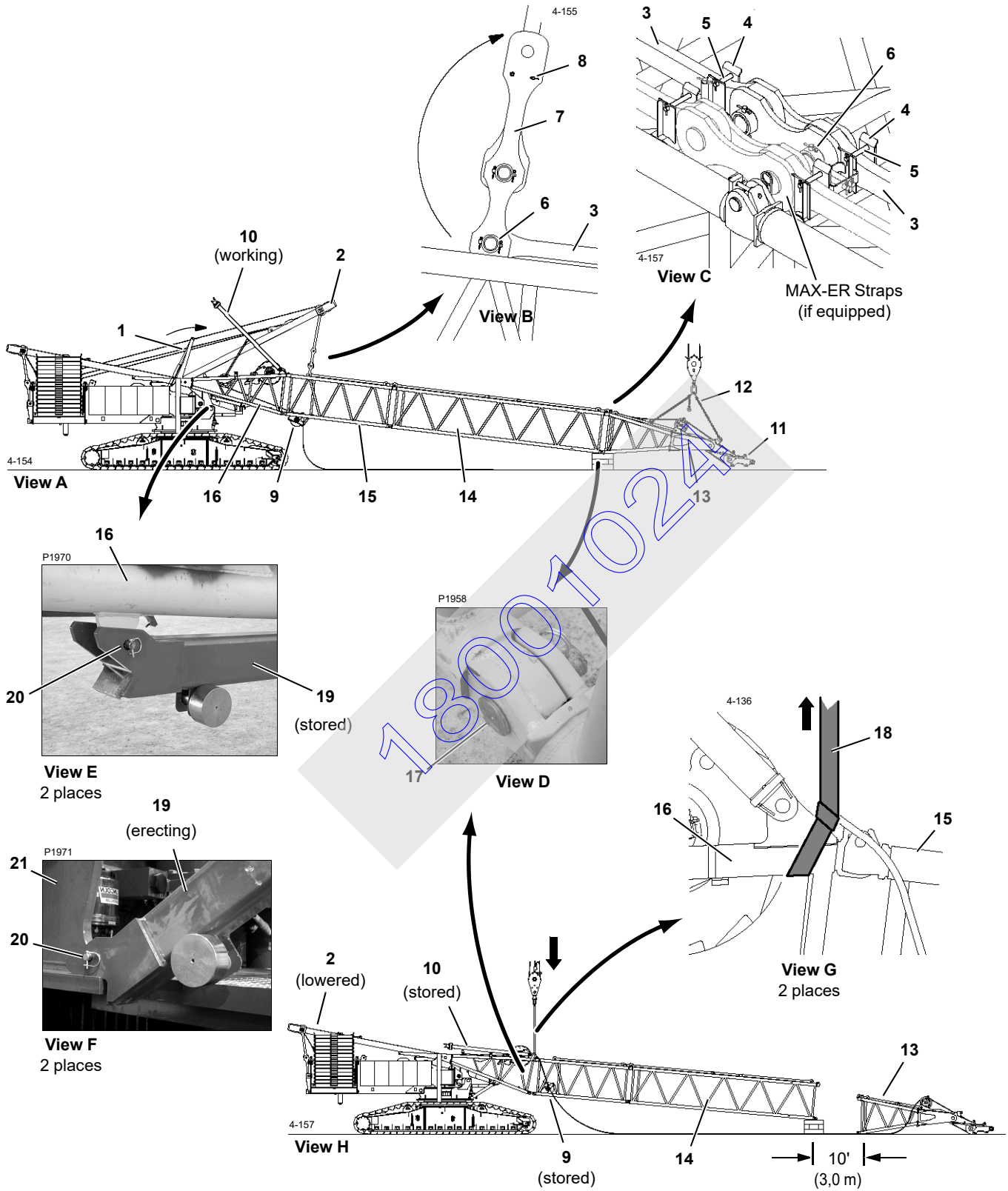

FIGURE 4-34



**Legend for Figure 4-34**

Item	Description
1	Mast Assist Arm
2	Live Mast
3	Fixed Mast Strap
4	Strap Bracket
5	Shipping Pin
6	Pin with Collar, Retaining Pin, and Cotter Pins
7	Adjustable Link
8	Pin with Cotter Pins
9	Wire Rope Guide (Drum 3)
10	Mast Stop
11	Boom Hoist Equalizer
12	Chain Sling
13	Mast Top
14	Mast Insert – 20 ft (6,1 m)
15	Mast Insert – 40 ft (12,2 m)
16	Mast Butt
17	Pin with Safety Pin
18	Nylon Lifting Slings (Owner Supplied)
19	Mast Support
20	Pin with Snap Pins
21	Rotating Bed

**Disconnect Live Mast Straps**

See [Figure 4-34](#) for the following procedure.

- Using setup remote control, fully raise mast assist arms (1, View A).

**WARNING****Falling Mast Hazard!**

Mast assist arms must remain raised after live mast is disconnected from fixed mast rigging. Live mast will fall over backwards if raised to vertical when arms are down.

- Lower live mast (2, View A) until fixed mast straps (3, View C) are resting in strap brackets (4).
- Remove shipping pins (5, View C) from storage and install in strap brackets (4).
- Remove pins (6, View C) from top end of links and place pins to side until mast sections are disassembled.  
Once mast sections are disassembled, install pins (6) in butt end of mast straps.
- Repeat steps 3 and 4 for MAX-ER straps, if equipped.

- Unpin adjustable links (7, View B) from fixed mast straps (3).
- If long end of adjustable links (7) is down, remove pins (8), rotate adjustable links 180°, and reinstall pins (8).  
Long end of adjustable links must be attached to live mast straps for storage as shown in View B.
- Position live mast (2) so it is out of the way during remaining steps.

**Store Wire Rope Guide**

To store wire rope guide if equipped with Drum 3, reverse steps under Lower Wire Rope Guide topic on [page 4-47](#).

**Store Mast Stops**

To store mast stops, reverse steps under Raise Mast Stops topic on [page 4-47](#).

**Remove Mast Inserts**

- If not already done, lift boom hoist equalizer (11, View A) into position on forks at end of mast top (13) with assist crane and install retaining pins ([Figure 4-33](#), View E).
- Attach slings (12) from assist crane to lifting lugs on mast top (13, View A).
- Slowly hoist against mast top until slings are just taut.
- Remove pins (17, View D) between mast top (13) and insert (14).

Store pins in tubes on end of insert.

- Lift mast top (13) clear of insert (14) and place mast top on ground approximately 10 ft (3,0 m) in front of insert (View H).  
Pay out wire rope from Drum 4 while performing this step.
- Disconnect chain slings (12).
- If necessary, secure mast supports (19, View E) so they cannot drop, remove pins (20), and lower mast supports.  
Store pins (20) in lugs on mast butt.
- Attach nylon lifting slings (18, View G) from assist crane to top chords at end of mast butt (16).
- Slowly hoist against mast butt until slings are just taut.
- Remove pins (17, View D) between mast butt (16) and insert (15).
- Slowly lower mast butt until mast supports (19) engage rotating bed (21) and lifting slings slacken.
- Disconnect lifting slings (18) from mast butt.

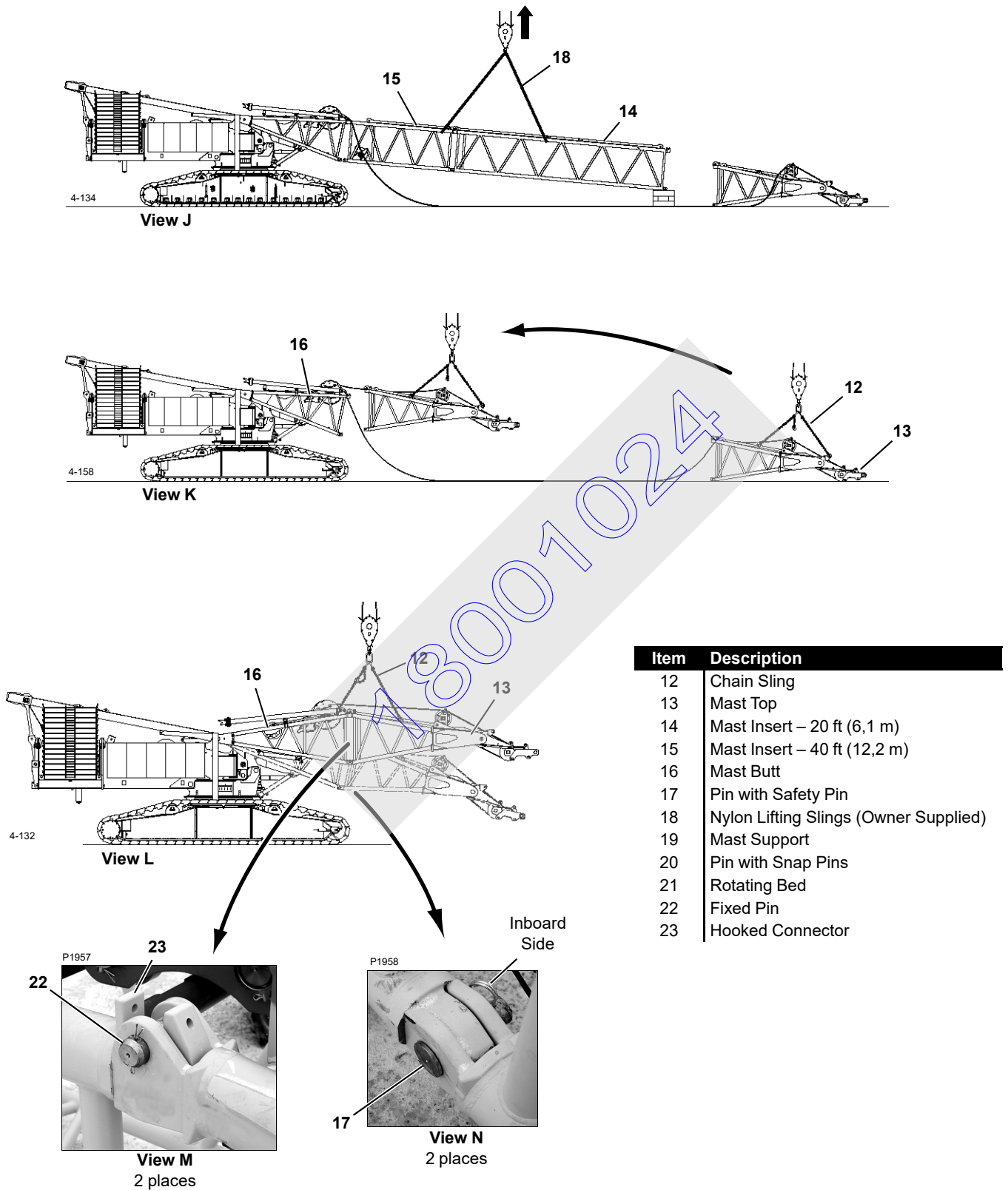

FIGURE 4-34 continued

- Attach nylon lifting slings (18) from assist crane to top chords of mast inserts (14 and 15, View J).

**Lift against chords only — never lift against lacings.**

**Adjust slings so insert lifts level.**

- Lift inserts (14 and 15) clear of mast butt and place inserts on blocking at least 8 in (203 mm) high.
- Disassemble inserts if required.
- Attach chain slings (12, View K) from assist crane to lifting lugs on mast top (13).
- Lift mast top into position next to mast butt.  
Haul in wire rope on Drum 4 while performing this step.
- Engage fixed pins (22, View M) in mast top with hooked connectors (23) in mast butt.
- Lower mast top until bottom connector holes line up.
- Install pins (17, View N).
- Disconnect chain slings (12).

### Remove Mast Butt and Top

The mast butt, mast top, and boom hoist equalizer are shipped assembled.

See [Figure 4-27](#) for the following procedure.

- Attach chain sling (3, View A) from assist crane to lifting lugs on mast butt and mast top.

**Grab hooks must be toward mast butt. Shorten both rear legs of sling by 13 links to provide proper lifting balance.**

- Unpin keeper plates (1, View C) and rotate them out of way. On current production cranes, pin the keeper plate to shoulder screw (11) to retain the keeper plate.

**NOTE** Alignment pins (9) are not installed during mast removal.

- Slowly hoist against mast top until mast supports (7, View F) disengage rotating bed.
- Remove mast support pins (8) from storage, raise mast supports (7), and pin supports in stored position (View E).
- Using remote control, disengage mast connecting pins.
- Lift mast butt and top away from crane.
- For Serial Number 18001113 and newer, deploy mast supports (see [page 4-41](#)).
- Place mast top and butt on transport vehicle and disconnect lifting slings.
- Using setup remote control, engage mast connecting pins for storage in rotating bed and engage keeper plates (1, View B).

### Remove Rear Platforms and Catwalk (Past Production)

To remove rear platforms and catwalk, reverse steps under Install Rotating Bed Catwalks and Steps topic on [page 4-20](#) (Past Production).

### Remove Rear Platforms and Catwalk (Current Production)

To remove rear platforms and catwalk, reverse steps under Move Platforms Into Working Position on [page 4-26](#), Install Cab Rear Platform on [page 4-26](#), Install Cab Left Platform on [page 4-24](#), and Install Rotating Bed Side and Rear Catwalks and Steps (Current Production) on [page 4-22](#).

### Remove Crane Counterweight

The crane (upperworks) counterweight must be removed with an assist crane.

**Do not remove carbody counterweight until crane counterweight is removed.**

See [Figure 4-25](#), Views B - D for the following procedure.

- Attach chain sling from assist crane to lifting lugs (6, View D) on counterweight box (13). Lift one box at a time.
- Boom, swing, and hoist as necessary to lift box off counterweight tray and lower to ground or transport vehicle.
- Disconnect chain sling.
- Repeat steps 1–3 for remaining counterweight boxes.  
**Alternate from side to side when removing boxes.**
- Attach chain sling to lifting lugs (6, View D) on counterweight tray (7).
- Hoist against counterweight tray so sling is taut and retaining pins (12, View C) are loose.
- Remove retaining pins (12) from notched pins (11).
- Hoist counterweight tray so top hooks (9, View B) disengage fixed pins (10) in rotating bed.
- Boom, swing, and hoist as required with assist crane to guide counterweight tray away from rear rotating frame.
- Place counterweight tray on transport vehicle.
- Disconnect chain sling.
- Repeat steps for tray on opposite side.

### Install Assembly Block

The assembly block must be installed to use the live mast for disassembly. See Install Assembly Block topic on [page 4-33](#).

***THIS PAGE INTENTIONALLY LEFT BLANK***

18001024

### Remove Carbody Counterweight

Carbody counterweights may be removed with the live mast. Reverse steps under Install Carbody Counterweight topic on [page 4-39](#).

Mast can be used as a boom with mast hoist control for disassembly. Use mast as a boom within 114°–160° operating range.

**NOTE** The mast will stop lowering, the operating limit alert will come on, and MAST TOO FAR FWD will appear on the digital display if the mast is lowered to 160°.

**! WARNING**  
**Falling Mast Hazard!**

Prevent mast from falling:

- Do not use limit bypass to lower mast below 160°. Mast will fall suddenly. **Connect an assist crane to end of live mast when it is necessary to lower it below 160°.**
- Mast assist arms must remain raised while using live mast as a boom. Mast will fall over backwards if raised to vertical when arms are down.

### Deploy Rear Rotating Bed Jacks

**NOTE** The front rotating bed jacks remain stored. **Do not deploy them at this time.**

Perform steps 2a through 2d on [page 4-12](#) and steps 3 and 4 on [page 4-14](#) for both rear rotating bed jacks.

**CAUTION**

**Jack Damage!**

Prevent damage to jacks:

See [Figure 4-35](#) for the following steps.

- **BEFORE JACKING:**  
pin jack pad support rod (2, View A) in retracted position so jack pad is level.
- **BEFORE SWINGING** with crawlers installed:  
pin jack pad support rod (2, View B) in extended position so jack pad is tilted. **Damage will occur if this step is not performed. Jack pad will strike crawlers while swinging crane.**

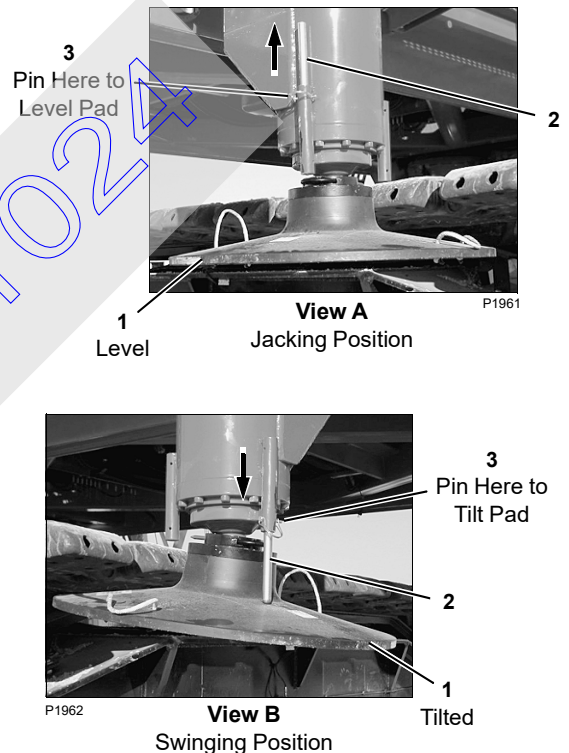

Item	Description
1	Jack Pad
2	Jack Pad Support Rod
3	Hair-Pin Cotter

FIGURE 4-35



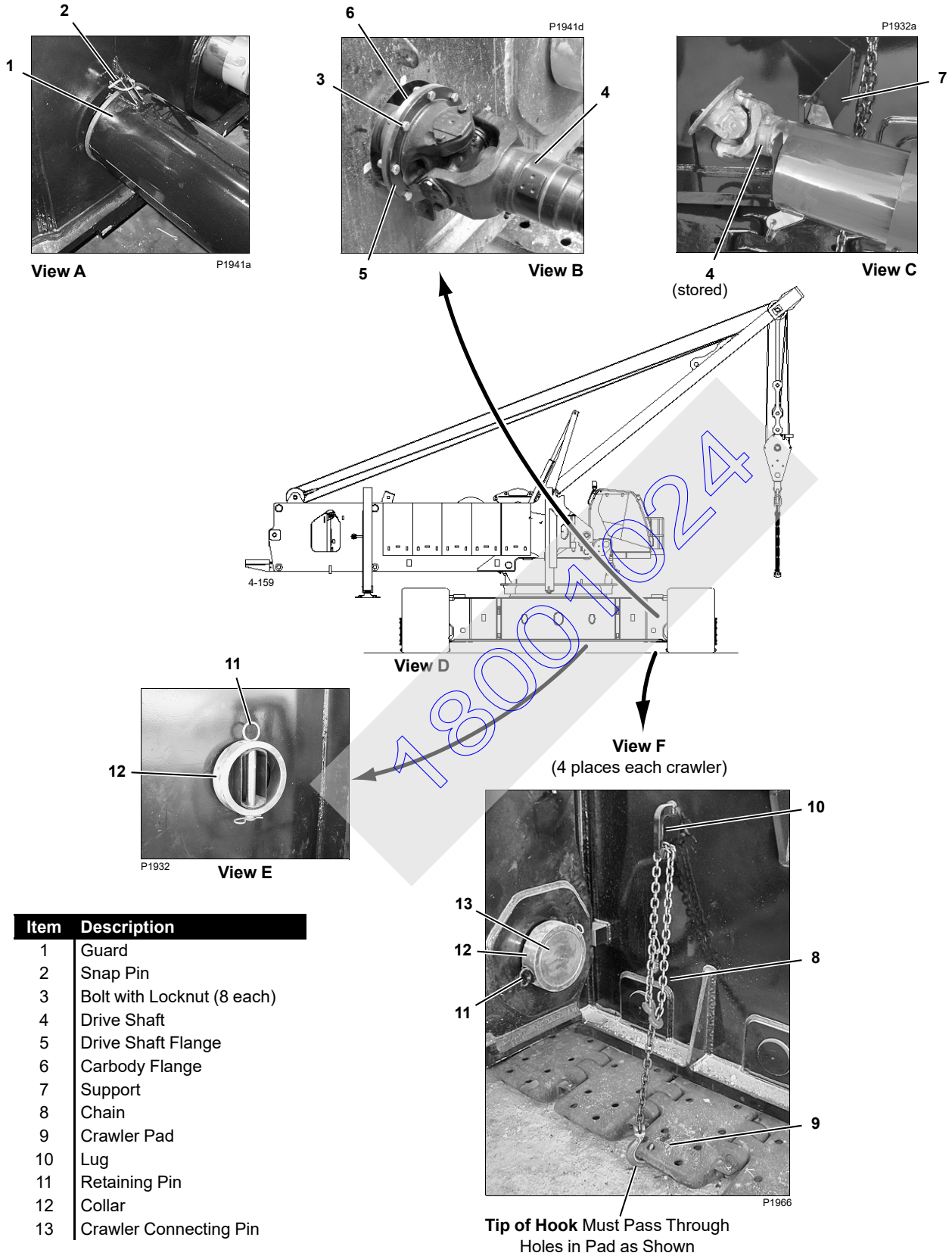

Item	Description
1	Guard
2	Snap Pin
3	Bolt with Locknut (8 each)
4	Drive Shaft
5	Drive Shaft Flange
6	Carbody Flange
7	Support
8	Chain
9	Crawler Pad
10	Lug
11	Retaining Pin
12	Collar
13	Crawler Connecting Pin

Tip of Hook Must Pass Through Holes in Pad as Shown

FIGURE 4-36



## Remove Crawlers

Mast should be operated between 114° (mast arms fully extended) and approximately 150° — 26 ft (7,9 m) radius — while lifting crawlers. Maximum capacity is limited to 120,000 lb (54 430 kg).

### Remove First Crawler

Unless otherwise specified, see [Figure 4-36](#) for the following procedure.

1. Disconnect grease lines between carbody and crawler, ([Figure 4-18](#), View D).

**NOTE** Loop grease lines together for shipping.



### WARNING

#### Rotating Shaft Hazard!

Rotating drive shaft can cut or crush:

- Drive shaft can spin unexpectedly during disassembly. To prevent serious injury to hands or fingers, perform the following steps when disconnecting drive shafts.
2. Disconnect crawler drive shaft as follows:
    - a. Travel both crawlers straight forward several feet (meters).

- b. Then travel both crawlers in required direction to slacken top crawler pads at drive shaft end of both crawlers.

- c. Unpin drive shaft guard (1, View A) from carbody and slide guard back only enough to access bolts (3, View B).

- d. Remove bottom bolts first. Remove top outermost bolt last (easiest bolt to access).

With one bolt remaining, have assistants support drive shaft with guard. Do not support it by holding flange or shaft with hands. **Drive shaft may spin when last bolt is removed.**

Remove last bolt carefully using a long extension between bolt and ratchet or impact wrench.

Do not use your fingers to remove last bolt. KEEP HANDS CLEAR of drive shaft flange.

- e. Retract crawler drive shaft (4, View C) and place on storage bracket (7).

3. Attach chains (8, View F) to crawler pads (9) and lugs (10) on crawler frame (four places). Chains must be snug so crawler pads do not sag when crawler is lifted.

4. Remove retaining pin (11, View F) and collar (12) from both crawler connecting pins (13).

5. Store collars as shown in View E.

18001024



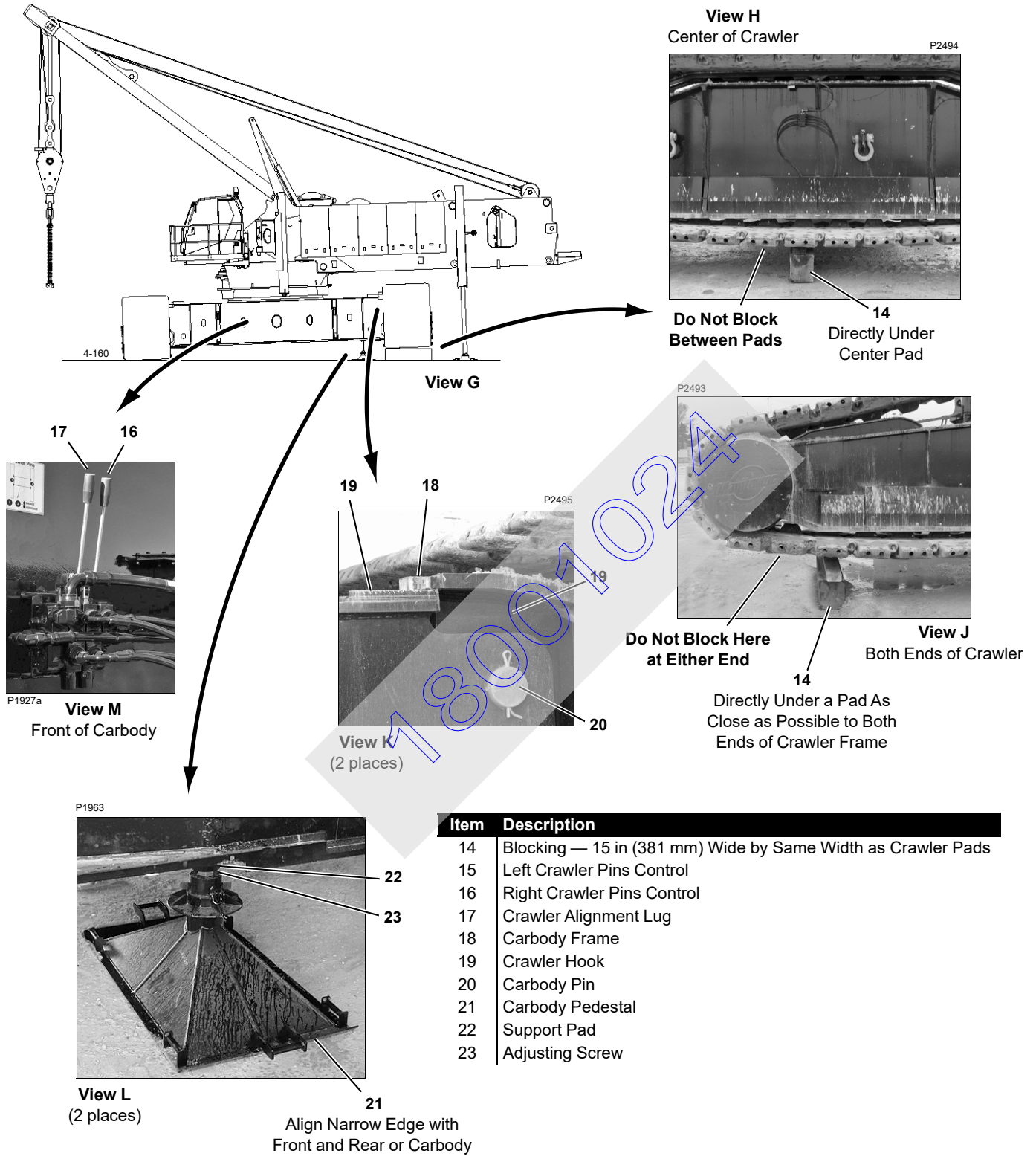

FIGURE 4-36 continued

6. Position jack pads as shown in [Figure 4-35](#), View B.
7. Swing upperworks so rotating bed is perpendicular to carbody and rear jacks are next to crawler to be removed (View G).

**Swing slowly while watching rear jack pads as they approach crawler pads. If crawler pads are tight, it may be necessary to remove jack pads so they don't hit crawler pads.**
8. Extend rear jacks until jack pads are approximately 2 ft (0,6 m) off the ground.
9. Position jack pads as shown in [Figure 4-35](#), View A so they hang freely (parallel with ground). **Damage will occur if this step is not performed.**
10. Extend jacks until they are snug against ground.
11. Disengage crawler connecting pins (13, View F) using controls on front of carbody (View M).
12. Extend jacks until crawler is approximately 18 in (457 mm) off ground.
13. Place hardwood blocking under crawler pads as shown in Views H and J.
14. Retract jacks just enough to break connection between crawler alignment lugs and carbody frame as shown in View K.

**Do not disengage crawler hook (19, View K) from carbody pin (20).**
15. Adjust jacks so carbody is level front to rear.
16. Place carbody pedestals (21, View L) under carbody support pads (22). The pedestals can be lifted with a fork-lift truck.
17. Adjust pedestal screws (23, View L) so they are snug against support pads (22).
18. Retract rotating bed jacks to lower carbody onto pedestals.

Procedure continues on [page 4-73](#).

18001024

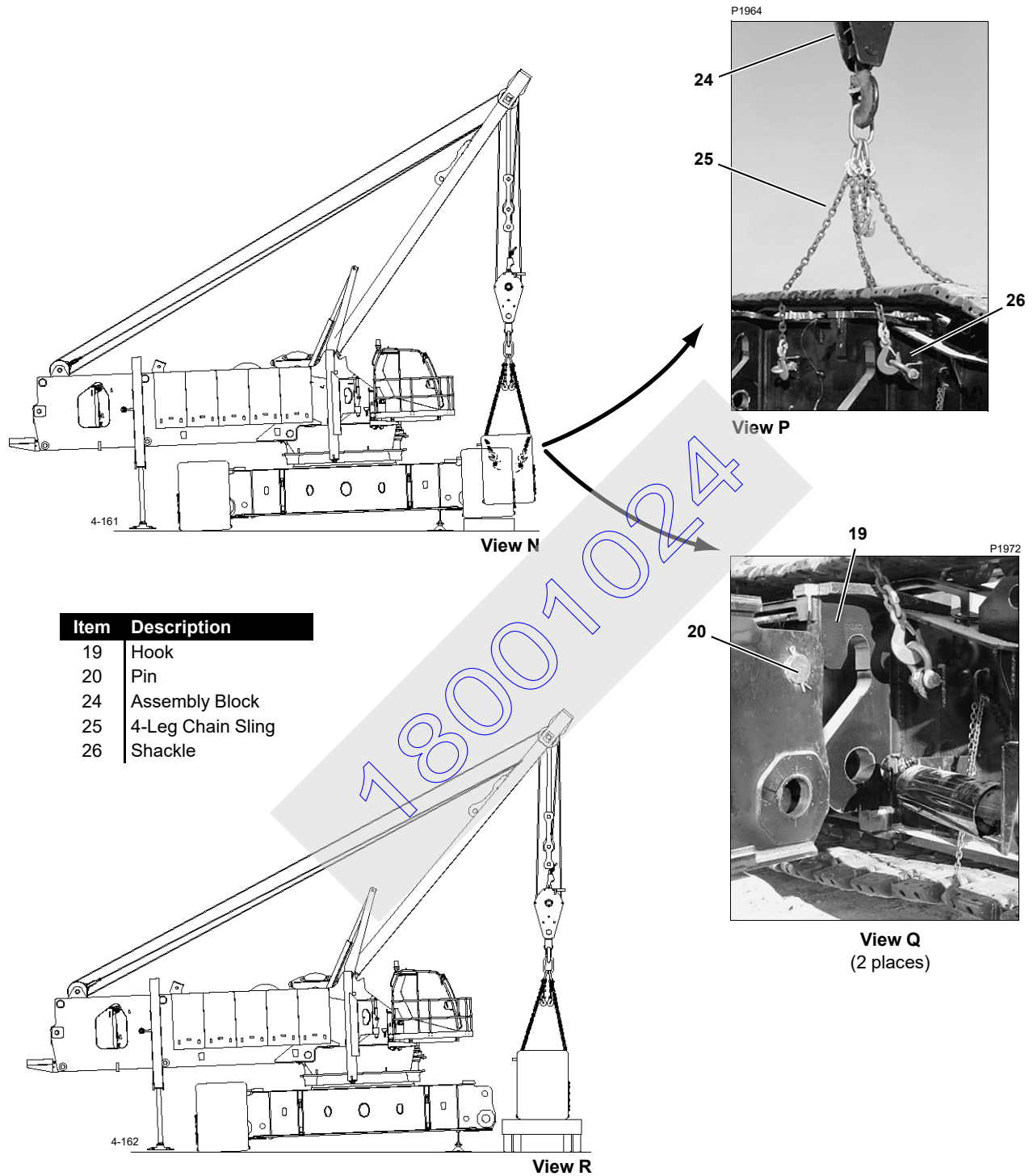

FIGURE 4-36 continued

19. Fully retract rear jacks.
20. Position jack pads as shown in [Figure 4-35](#), View B.
21. Swing 180° so mast is over crawler to be removed (View N).

**Swing slowly while watching rear jack pads as they approach crawler pads. If crawler pads are tight, it may be necessary to remove jack pads so they don't hit crawler pads.**

22. Extend rear jacks until jack pads are approximately 2 ft (0,6 m) off ground.
23. Position jack pads as shown in [Figure 4-35](#), View A so they hang freely (parallel with ground). **Damage will occur if this step is not performed.**
24. Extend jacks until they are 2-3 in (51-76 mm) from contacting the ground.
25. Raise mast so assembly block (24, View P) is centered over crawler.
26. Attach hooks from chain sling (25, View P) to shackles (26) on crawler — two legs with grab hooks to rear.
27. Position chains between crawler pads as shown in View P.
28. Hoist and mast up or down as needed so crawler hooks (19, View Q) disengage carbody pins (20).

If necessary, adjust length of rear chains so crawler lifts level.

**Crawler should be lifted as level as possible** — both front to rear and side to side.

29. Slowly hoist crawler clear of carbody.
30. Place crawler assembly on trailer (View R).

Disconnect chain sling from crawler assembly.

**NOTE** The crawler connecting pins are shipped in the retracted position to meet shipping width requirements.

### Remove Second Crawler

**Swing is limited to 5° when handling second crawler after first crawler is removed** (see [Figure 4-21](#), View D).

Repeat steps under Remove First Crawler on [page 4-69](#) to remove second crawler.

After second crawler is removed, swing only enough to align rotating bed with carbody and ENGAGE SWING LOCK.



### WARNING Tipping Hazard

To prevent tipping after second crawler is removed:

- Swing only enough to align rotating bed with carbody.
- Engage swing lock.

Do not attempt to swing any more than 5° to either side of center during remainder of disassembly procedure.

### Remove Assembly Block

Reverse steps under Install Assembly Block topic on [page 4-33](#).

### Store Live Mast

See [Figure 4-20](#) for the following procedure.

Mast assist arms must be raised when lowering live mast.

1. Scroll to MAST ANGLE on digital display to monitor mast angles during lowering procedure.
2. MAST UP to lower mast to approximately 11° mast angle (View A).

Mast assist arms will automatically retract and support mast as mast is lowered.

3. Remove locking pins (5, View B) from live mast straps (4).
4. Remove pins (6, View B) stored on rotating bed and pin live mast straps to rotating bed.
5. Fully lower mast (0° mast angle).
6. Store locking pins (5, View B) in live mast straps.

### Remove Drum 3 (Whip Line Drum)

Reverse steps under Install Drum 3 topic on [page 4-22](#).

### Deploy Front Rotating Bed Jacks

Perform steps 2a through 2d on [page 4-12](#) and steps 3 and 4 on [page 4-14](#) for both front rotating bed jacks.

## Separate Rotating Bed From Carbody

1. Disconnect hydraulic hoses on sides of adapter frame and rotating bed ([Figure 4-18](#)).

**NOTE** Do not disconnect hydraulic hoses to rotating bed jacks.

2. Loop hydraulic lines together for shipping (see [Figure 4-18](#)) or install dust caps.
3. Disconnect electric cables and store ([Figure 4-18](#), Views A and B).
4. Remove rotating bed catwalks and steps. Reverse procedure under Install Rotating Bed Catwalks and Steps topic ([page 4-20](#)).
5. Using remote control, fully extend rotating bed jacks to lift upperworks and carbody off carbody pedestals ([Figure 4-13](#), View A). **Keep crane level while extending jacks.**
6. Remove and store carbody pedestals.
7. Position trailer under carbody. **Take extreme care not to hit jacks with trailer. Provide a signal person to give instructions to truck driver.**
8. Slowly retract jacks until carbody rests on trailer ([Figure 4-12](#), View D). **Do not allow full weight of carbody, adapter frame, and rotating bed to rest on trailer. Weight may exceed trailer capacity.**
9. Remove retaining pins from connecting pin latches (8, [Figure 4-12](#), View G) and rotate latches out of way.
10. Using remote control, disengage front and rear adapter frame connecting pins (6, [Figure 4-12](#), View F).
11. Slowly extend jacks to separate rotating bed from carbody and adapter frame.
12. Tie down carbody and adapter frame to trailer. Remove trailer ([Figure 4-12](#), View A).
13. Using remote control, engage adapter frame pins for storage. Secure pins with keeper plates and retaining pins.

## Place Rotating Bed on Trailer

1. If necessary, fully extend rotating bed jacks ([Figure 4-9](#), View B).
2. Position trailer under rotating bed. **Take extreme care not to hit jacks with trailer. Provide a signal person to give instructions to truck driver.**
3. Lower rotating bed onto trailer.
4. Fully retract jacks.
5. Configure the enclosure assembly panels to shipping position 2 if the front face of the rotating bed is facing the

truck cab (see Configure Enclosure Panels on [page 4-29](#) and reverse step one).

6. Remove steps and store all catwalks.

Perform the following procedures before tying down rotating bed to trailer.

## Store Operator's Cab

Reverse steps under Deploy Operator's Cab topic on [page 4-14](#).

## Remove Rotating Bed Jacks

Store the jack pads (see [Figure 4-7](#)).

If required for shipping, remove rotating bed jacks. Reverse steps under Deploy Rotating Bed Jacks topic on [page 4-12](#).

### CAUTION

#### Jack Damage

Connect hydraulic hose (1, [Figure 4-37](#)) from jack (2) to coupler (3) on jack for following conditions:

- When jack is removed from crane for shipping or storage.
- Anytime hose between crane and jack will be disconnected for an extended time.

Cylinder seal can be damaged if this step is not performed

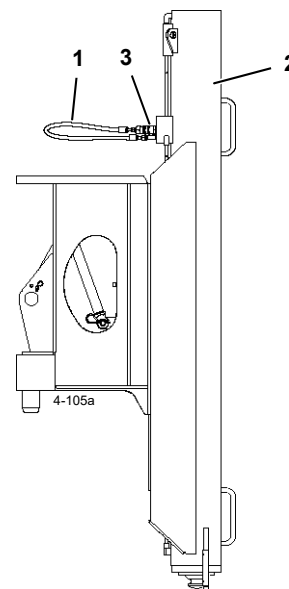

FIGURE 4-37

## Install Wind Deflectors

If equipped, reverse steps under Remove Wind Deflectors topic on [page 4-10](#).

*THIS PAGE INTENTIONALLY LEFT BLANK*

18001024



## BOOM LADDER ASSEMBLY



### WARNING

#### To Prevent Serious Injury or Death:

- Limit load on ladder to 300 lb (136 kg).
- Avoid improper use. Ladder is intended for use only on Manitowoc #79A and #55 boom inserts. Any other use is prohibited.
- Use ladder for boom assembly/disassembly and maintenance only when boom is horizontal.
- Make sure ladder is properly secured to insert.
- Keep hands free of any objects while climbing ladder. Objects which cannot be carried in pockets or tool belts must be lifted into place onto ladder platform prior to climbing ladder.
- Stand only on platform. Do not stand on cross braces.

### General

If equipped, two optional ladders are stored at the following locations:

- Current Production: inside the 40 foot (12,2 m) insert that is installed next to the boom butt as shown in (see [Figure 4-38](#), View A)
- Past Production, inside the boom butt as shown in ([Figure 4-39](#), View A)

The ladders are designed for use in assembly/disassembly and maintenance of #79A and #55 boom sections and components. Each ladder weighs approximately 35 lb (16 kg).

### Removing Ladders from Boom Section

It is recommended that two people remove each ladder: one person inside boom section to unlatch and lift ladder, and

another person outside of boom section to help guide ladder out of insert or butt. Use the following procedure:

1. Lower boom onto blocking at ground level. **Boom sections must be horizontal.**
2. Unhook rubber latches (View B).
3. Lift ladder up and out of hooks (View C).
4. Guide ladder through lacings to outside of insert or butt.

### Installing Ladders on Boom Inserts

Lift ladder to desired outside location on insert so that upper pads are securely hooked over backside of upper chord and lower pads rest firmly against lower chord (View D).

**Ladder must hang vertically against boom insert when in use.**

### Storing Ladders



### WARNING

#### Falling Load Hazard!

Ladders must be properly stored to prevent them from falling out of insert when boom is raised.

It is recommended that two people install each ladder: one person outside boom section to help guide ladder into insert or butt, and another person inside of boom section to lift ladder and latch it in position. Use the following procedure:

1. Hang ladder rails over hooks inside insert (View C).
2. Pull rubber latches tightly over lower rail and latch in keepers (View B).
3. Ensure ladder cannot move once latched in place.



4-163

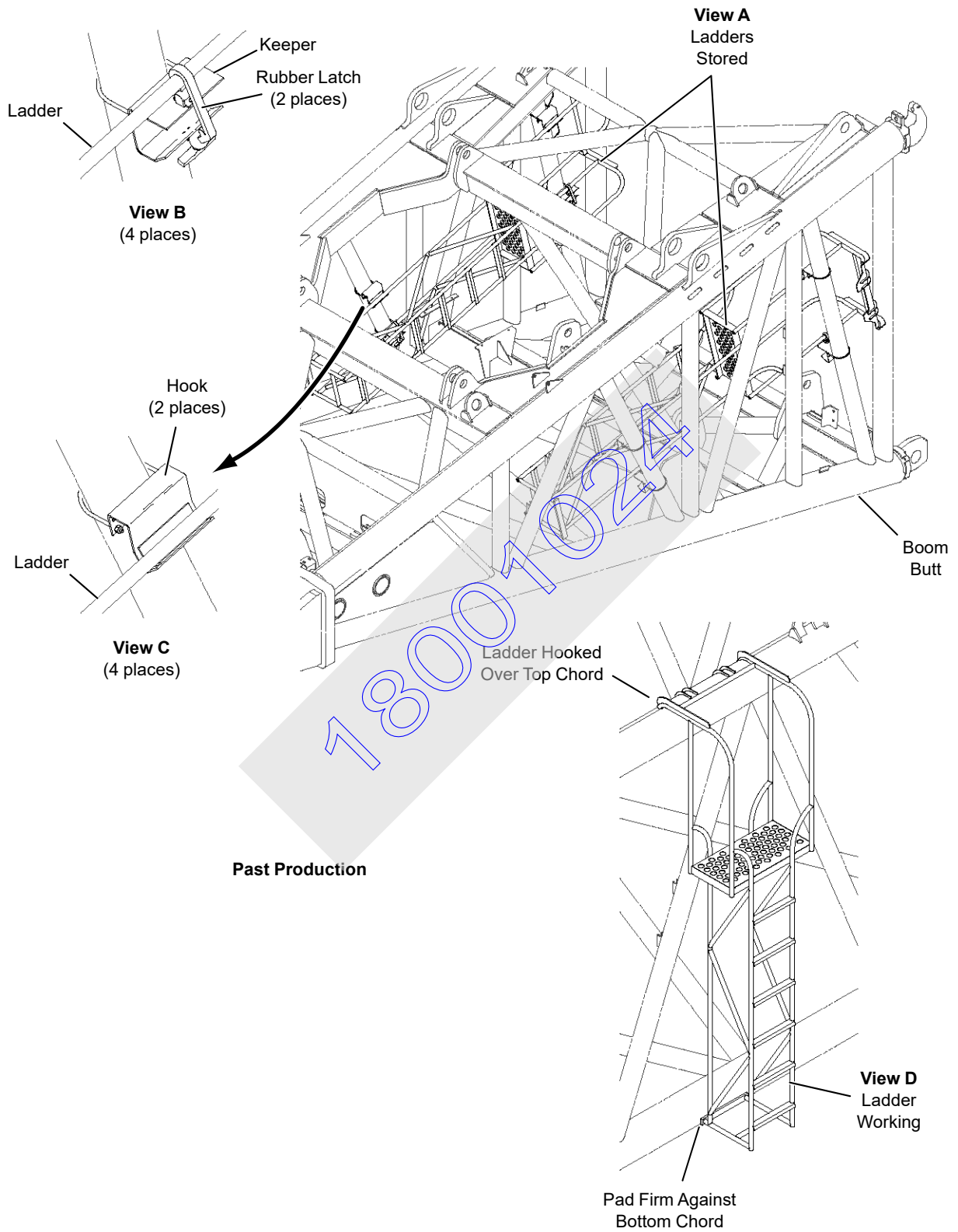

FIGURE 4-38

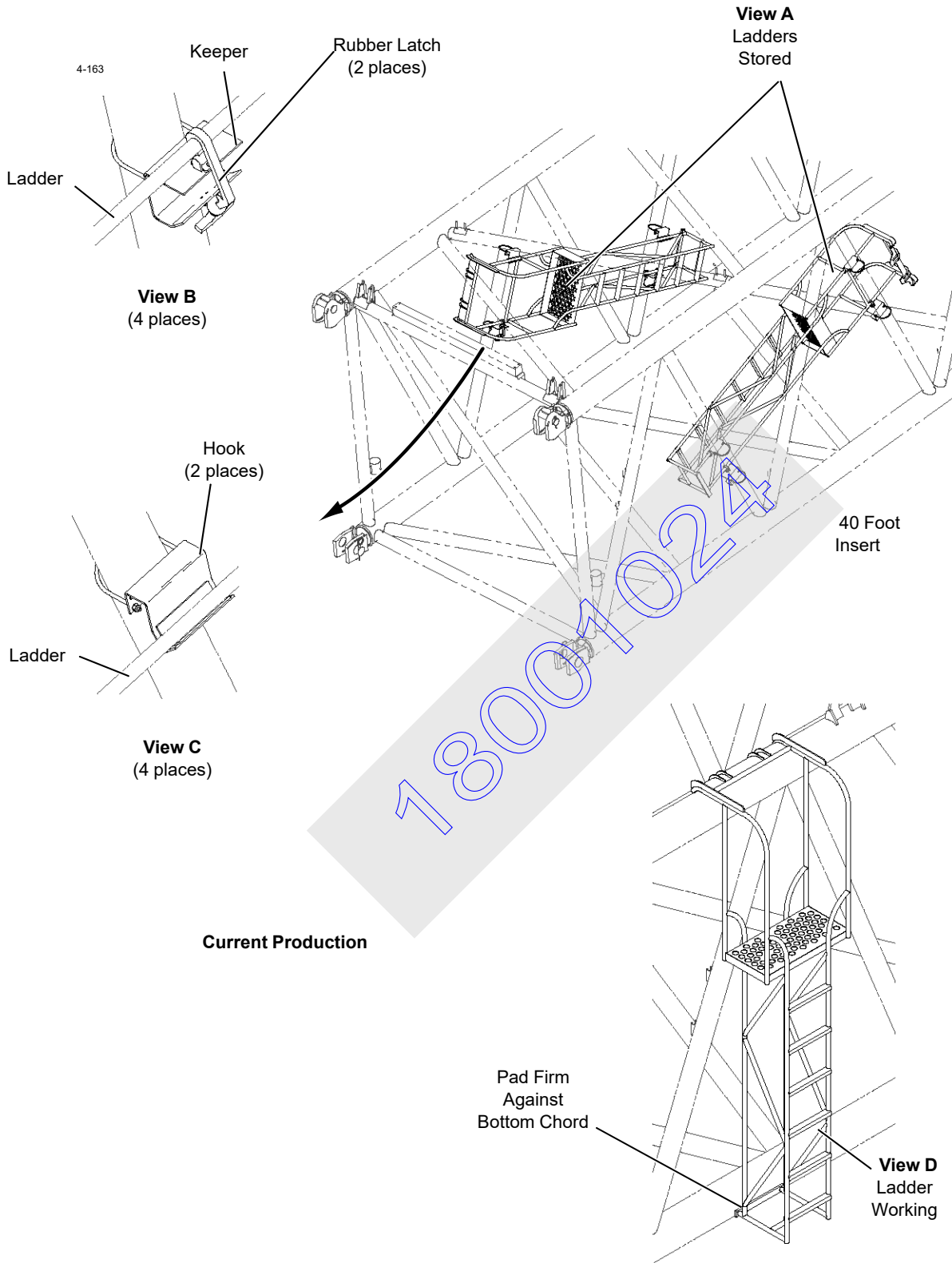

FIGURE 4-39

*THIS PAGE INTENTIONALLY LEFT BLANK*

18001024

## BOOM AND JIB RIGGING

### Assist Crane Requirements

An assist crane capable of handling the boom and jib sections and lifting one-half the weight of the boom (or jib) is required. See Crane Weights in Section 1 for the weights of boom and jib sections.

### Blocked Crawler

To prevent the crane from tipping, some boom and jib lengths must be raised and lowered over the end of blocked crawlers. See capacity charts for blocked crawler requirements and Crawler Blocking Diagram in Capacity Chart Manual for instructions.

Do not attempt to raise or lower boom from or to ground until crawlers are blocked, if required.

 **WARNING**  
**Tipping Hazard**

Block ends of crawlers, if required, before you attempt to raise or lower boom from or to ground.

### Handling Components

Handle boom and jib sections with care to avoid damaging lacings and chords. The boom and jib sections have lifting lugs designed to provide a balanced load and to prevent damage during lifting.

 **WARNING**  
**Falling Load Hazard!**

Lifting lugs on a particular boom or jib section are designed for lifting that section only. Do not attempt to lift two or more boom or jib sections with lifting lugs only on one section. Lifting lugs may break allowing boom or jib sections to fall.

When lifting lugs are not used:

- Lift against chords only, never against lacings.
- Use nylon lifting slings. If wire rope or chain slings are used, install protective covering (such as sections of rubber tire) between slings and chords.

### Rigging Assembly Drawings

Boom and jib sections (top, inserts, straps) must be assembled in proper sequence according to applicable Boom and Jib Rigging drawings at the end of this section.

### Medium Inserts

Medium inserts have lighter weight chords and lacing than regular inserts, as indicated in the following table. The diameter of the lacings is the most visible difference.

	Medium Insert		Regular Insert	
	Outside Diameter	Wall Thickness	Outside Diameter	Wall Thickness
Lacings	4 in (101,6 mm)	0.25 in (6,4 mm)	4.25 in (108,0 mm)	11/32 in (8,7 mm)
Chords	8-47/64 in (221,7 mm)	35/64 in (14,0 mm)	8-47/64 in (221,7 mm)	3/4 in (19,1 mm)

Medium inserts are required as follows:

- Cranes equipped with a 140 ft (42,7 m) mast and boom 320 ft (97,5 m) or longer
- Cranes equipped with a 100 ft (30 m) mast and boom 320 ft (97,5 m) long

The medium insert(s) must be installed as shown in the Boom Rigging Assembly Drawings.

 **DANGER**

**Collapsing Boom Hazard!**

Boom will collapse if medium inserts are installed in incorrect assembly sequence. Follow the assembly sequence indicated in the Boom Rigging Assembly Drawings.

### Identifying Boom and Jib Sections and Straps

Boom and jib sections are marked for proper identification as shown in Views A and B, [Figure 4-40](#).

Boom and jib pendants are marked for proper identification as shown in View C, [Figure 4-40](#).

Boom straps and links are marked for proper identification as shown in View D, [Figure 4-40](#).

**NOTE** The markings shown in [Figure 4-40](#) can vary depending on when your crane was produced and the original equipment manufacturer.

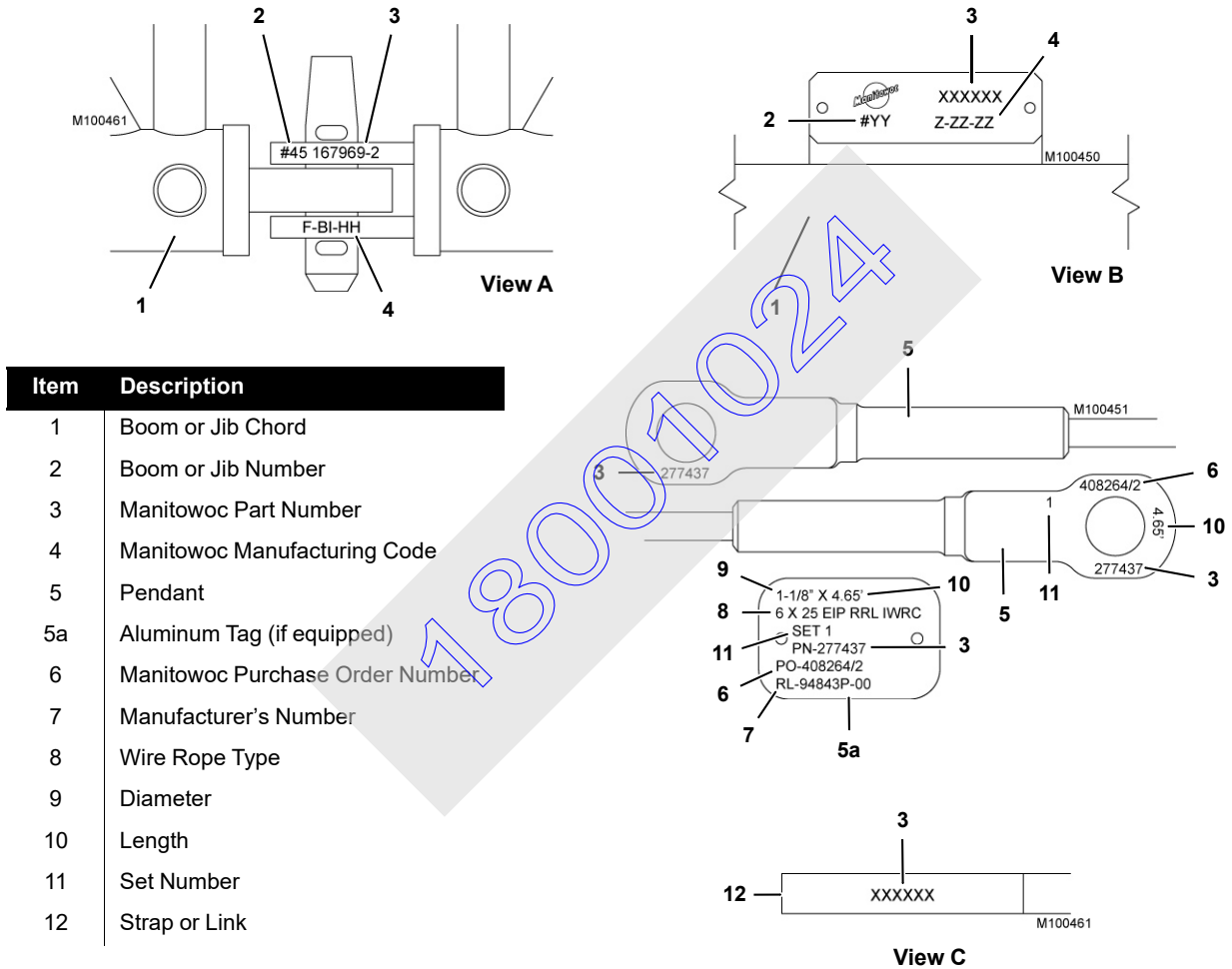

FIGURE 4-40

*THIS PAGE INTENTIONALLY LEFT BLANK*

18001024

## Boom Installation



### WARNING

#### Crushing Injury Hazard!

Never work under or inside boom sections that are not securely blocked.



### WARNING

#### Falling Load Hazard!

Jib backstay straps can be stored on boom sections for shipping.

If jib will not be used, remove all jib backstay straps, links, and pins stored on boom sections.

### Inspect Boom Stops

See [Figure 4-41](#) for the following procedure.

Jib stops (2) are shipped in the assembled position on boom butt (1) as shown in View A.

Before installing the boom butt, inspect both jib stops for proper operation, as follows:

1. Fully raise and lower boom stop (2) by hand.
2. While performing step 1, strut (3) should extend and retract fully without binding.
3. Repeat steps 1 and 2 several times to make sure strut (3) operates freely without binding.
4. **OPERATOR**, observe jib stops during operation:

When the boom is raised to approximately 77°, boom stop pins (4) should bottom out in saddles (5).

**Stop operating immediately if boom stop pins do not engage saddles as boom is raised. Lower boom to ground and take corrective action.**

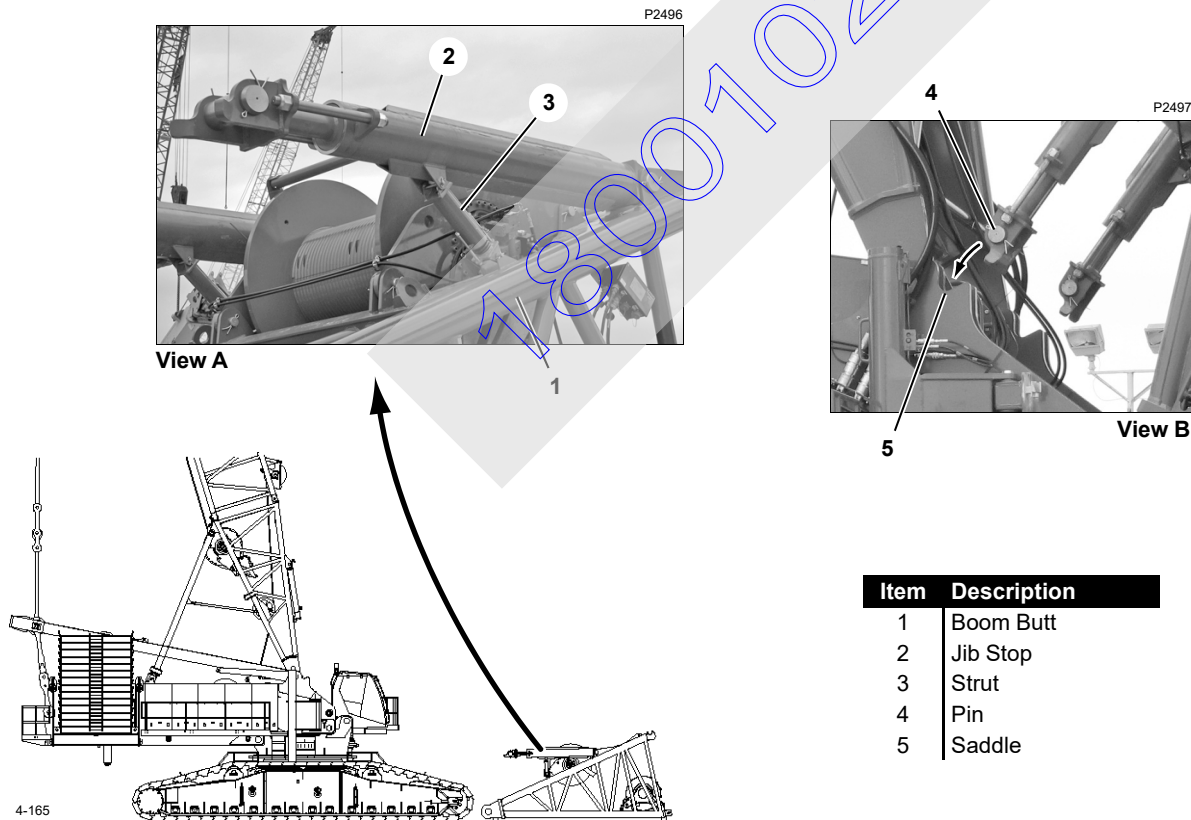

Item	Description
1	Boom Butt
2	Jib Stop
3	Strut
4	Pin
5	Saddle

FIGURE 4-41



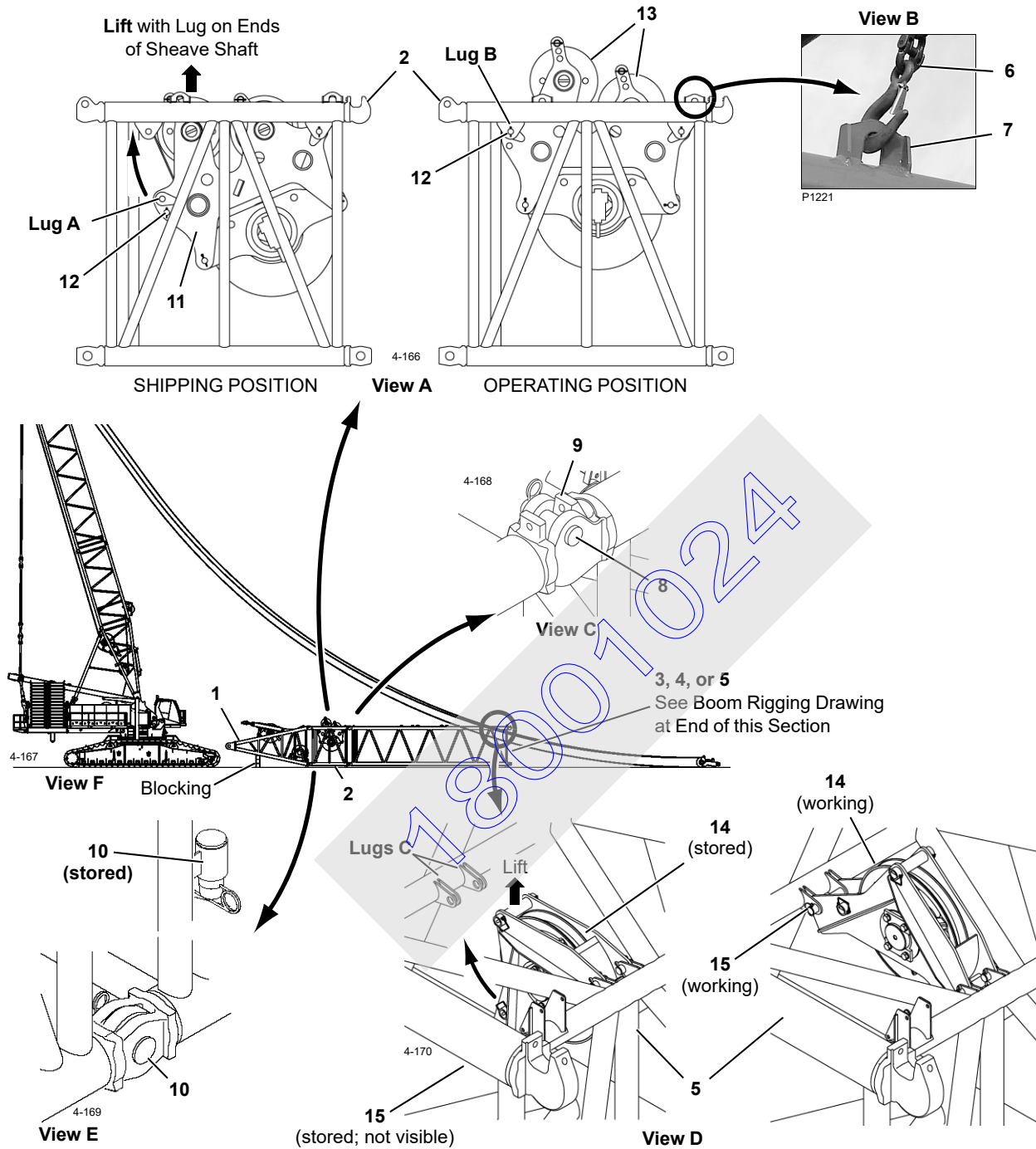

Item	Description	Item	Description	Item	Description
1	20 ft (6,1 m) #55 Boom Butt	6	Chain Sling	11	Drum Bracket
2	10 ft (3,0 m) #55 Insert	7	Lifting Lugs (4 places each insert)	12	Pin with Cotter Pin
3	20 ft (6,1 m) #55 Insert	8	Fixed Pin with Safety Pin (typical)	13	Drum 1 Wire Rope Guide
4	40 ft (12,2 m) #55 Insert	9	Hooked Connector (typical)	14	Drum 6 Wire Rope Guide
5	40 ft (12,2 m) #55 Insert with Drum 6 Sheaves	10	Connecting Pin with Safety Pin (typical)	15	Pin with Snap Pins

FIGURE 4-42

### Assemble Boom Butt and First Insert

See [Figure 4-42](#) for the following procedure.

1. Place boom butt (1) on blocking in front of crane as shown in View F. Centerline of butt must be parallel to ground.  
Lift with chain slings (6, View B) attached to four lifting lugs (7) on insert.
2. Remove bottom connecting pins (10, View E) from stored position in bottom connectors on 10 ft (3,0 m) insert (2).
3. Lift insert (2) into position at front of boom butt (1).  
Lift with chain sling (6, View B) attached to four lifting lugs (7) on insert.
4. Engage fixed horizontal pins (8, View C) in insert with hooked connectors (9) in butt.
5. Lower insert until bottom connecting holes line up.
6. Install bottom connecting pins (10, View E) and secure with safety pins.

**NOTE** On current production cranes, pins (10) are stored in tubes on the butt end of the insert.

7. Block under top end of insert.
8. Remove chain slings.

### Raise Drum 1 to Operating Position

See [Figure 4-42](#), View A for the following procedure.

Raise Drum 1 in 10 ft (3,0 m) insert as follows:

1. Attach slings from assist crane to lug on each end of sheave shaft.
2. Hoist until slings are just taut.
3. Remove pins (12) from stored position.
4. Hoist to rotate Drum 1 bracket (11) and guide sheaves (13) to operating position (holes in Lugs A and B aligned).
5. Install pins (12) through holes in lugs and secure with cotter pins.

6. Remove slings.

### Install Second Insert

See Boom Rigging Drawings at the end of this section to determine the proper insert to install.

1. **Remove jib backstay straps if stored on boom insert for shipping.**
2. Remove bottom connecting pins (10, View E) from stored position in bottom connectors on insert.
3. Lift required insert (3, 4, or 5, View F) into position at front of 10 ft (3,0 m) insert (2).  
Lift with chain slings (6, View B) attached to four lifting lugs (7) on insert.
4. Engage fixed horizontal pins (8, View C) in insert with hooked connectors (9) in adjacent insert.
5. Lower insert until bottom connecting holes line up.
6. Block under top end of insert.
7. Install bottom connecting pins and secure with safety pins (10, View E).
8. Remove chain slings.

### Raise Drum 6 Sheaves

**NOTE** Perform this procedure only if crane will be equipped with luffing jib.

See [Figure 4-42](#), View D for the following procedure.

1. Attach sling from assist crane to sheave assembly (14).
2. Hoist until sling is just taut.
3. Remove pin (15) from stored position.
4. Hoist to rotate sheave assembly (14) to operating position (holes in Lugs C and sheave assembly frame aligned).
5. Insert pin (15) through hole in lug and frame and secure with snap pin.
6. Remove sling.

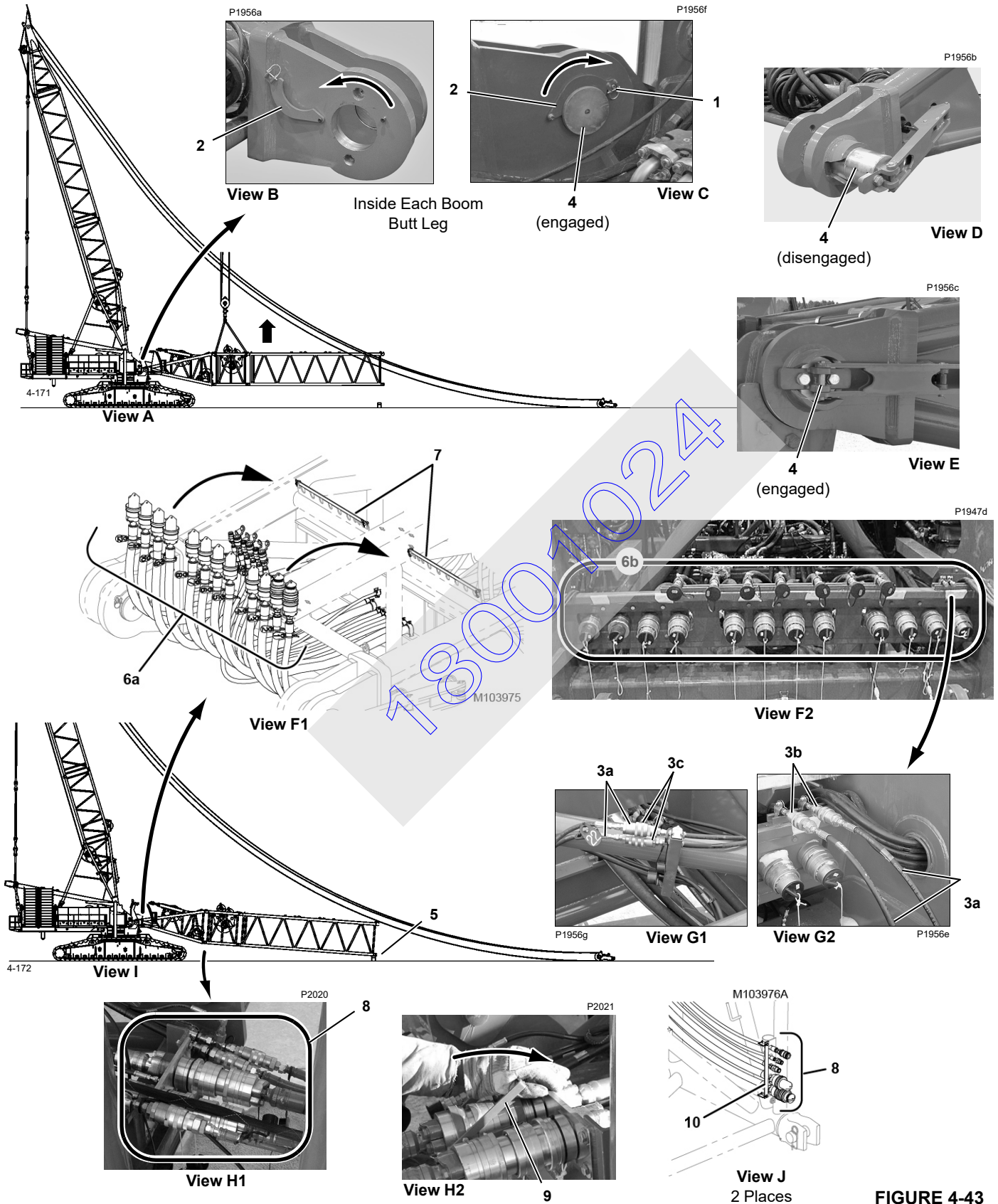

FIGURE 4-43

**Install Boom Butt and Assembled Inserts**

See [Figure 4-43](#) for the following procedure.

1. Attach nylon lifting slings from assist crane to top chords of assembled butt and inserts as shown in View A.

**Adjust position of slings so butt and inserts are horizontal when lifted.**

2. Lift butt and inserts into position at connecting holes in front of rotating bed (View A).
3. Unpin snap pins (1, View C) from keeper plates (2) and rotate keeper plates out of way (View B).
4. Disconnect hydraulic hoses (3a, View G1) from couplers (3c) on boom butt.

**Thoroughly clean couplers to prevent dirt from entering hydraulic system.**

5. Connect two hydraulic hoses (3a, View G1) from boom butt to couplers (3b) on left front side of rotating bed.

**Thoroughly clean couplers to prevent dirt from entering hydraulic system.**

6. Select and confirm SETUP REMOTE mode.  
See Remote Controls in Section 3 for operating instructions.

7. Using setup remote control, disengage boom hinge pins (4, View D).

8. Position assembled inserts so connecting holes in butt line up with connecting holes in rotating bed.

9. Using setup remote control, engage boom hinge pins (4, View E).

10. Engage keeper plates (2, View C) with groove in boom hinge pins (5) and install snap pins (1).

11. Lower assembled inserts onto blocking approximately 17 in (432 mm) high.

12. Disconnect slings.

13. Disconnect hydraulic hoses (3a, View G2) from couplers (3b) on rotating bed.

14. Connect hydraulic hoses (3a, View G1) to couplers (3c) on boom butt. **This step must be performed to relieve trapped pressure from boom hinge pin cylinders.**

15. Open storage brackets (7, View F1) on boom butt.

16. Remove dust covers from hydraulic hoses on rotating bed and boom butt.

**Thoroughly clean couplers to prevent dirt from entering hydraulic system.**

17. Connect hydraulic hoses (6a, View F1) on butt to couplers (6b, View F2) on rotating bed.

**NOTE** These are straight line connections. No hoses will cross when hoses are correctly connected.

On current production cranes, hoses and corresponding couplers are tagged with numbers (see [Figure 4-18](#), View L). Match numbers to ensure proper hose connection.

Coupler-assist tool (9, View H2) will be required to connect the large couplers.

18. Close storage brackets (7, View F1) on boom butt.

19. Remove dust covers on hydraulic hoses (8, View J) between butt and 10 ft (3,0 m) insert.

**Thoroughly clean couplers to prevent dirt from entering hydraulic system.**

20. Open storage brackets (10, View J) on boom butt.

21. Connect hydraulic hoses (8, View H1) between butt and 10 ft (3,0 m) insert.

**NOTE** The quick-couplers are arranged so the hoses can only be connected one way.

On current production cranes, hoses and corresponding couplers are tagged with numbers (see [Figure 4-18](#), View L). Match numbers to ensure proper hose connection.

Coupler-assist tool (9, View H2) will be required to connect the large couplers.

22. Close storage brackets (10, View J) on insert.

**Legend for [Figure 4-43](#)**

Item	Description	Item	Description
1	Snap Pin	6a	Hydraulic Hoses (boom butt)
2	Keeper Plate (boom hinge pin)	6b	Hydraulic Couplers (rotating bed)
3a	Hydraulic Hoses (boom butt)	7	Storage Bracket (1 or 2)
3b	Hydraulic Couplers (rotating bed)	8	Hydraulic Hoses (between boom butt and insert)
3c	Hydraulic Couplers (boom butt)	9	Coupler-Assist Tool
4	Boom Hinge Pin	10	Storage Bracket (2)
5	17 in (432 mm) Blocking		



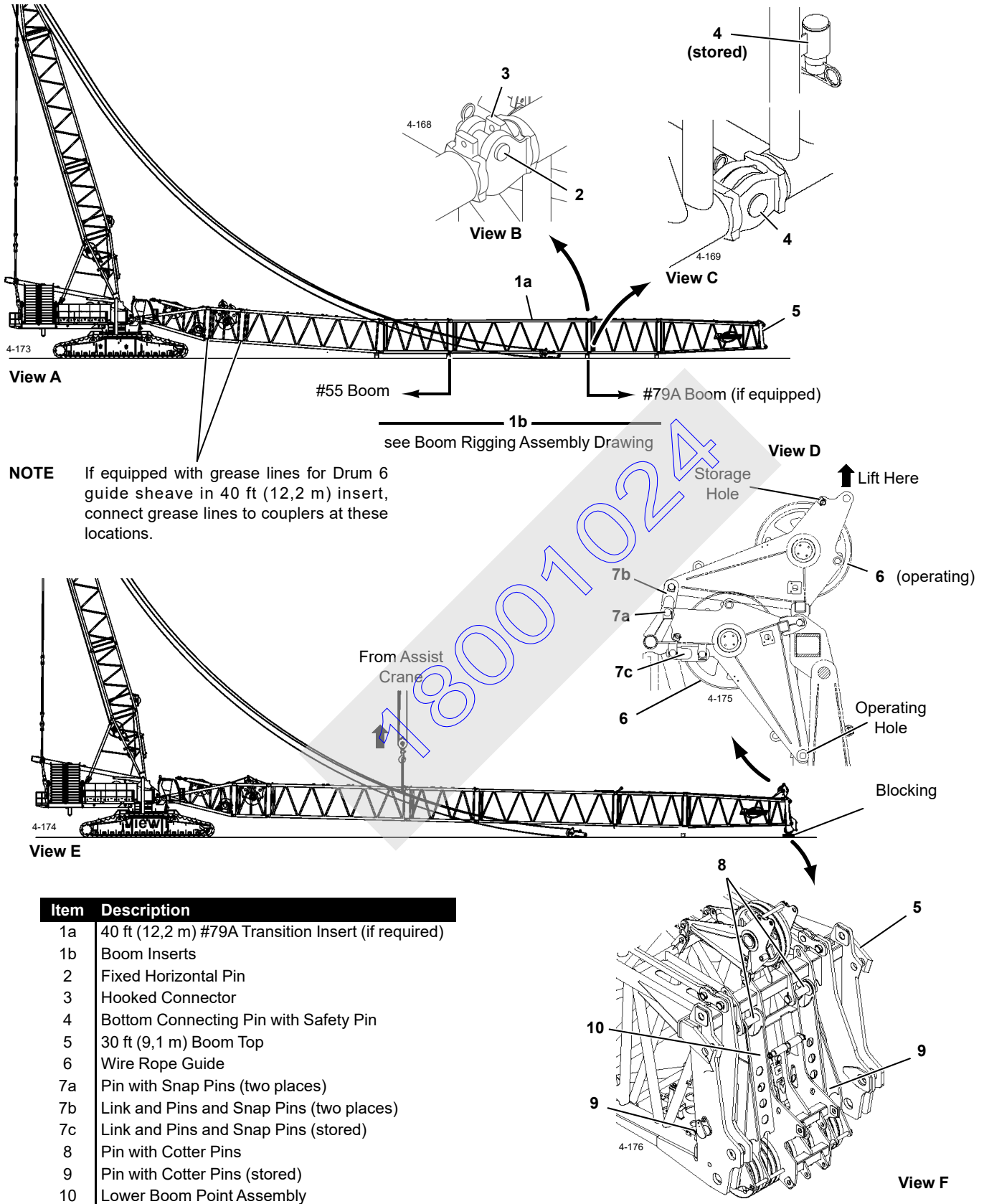

FIGURE 4-44

### Assemble Remaining Boom Sections

See [Figure 4-44](#) for the following procedure.

**Boom inserts, including medium insert if applicable, must be assembled in the proper sequence.** See Boom Rigging Assembly drawings at the end of this section for assembly sequence.

1. Jib backstay straps:

If backstay straps for luffing jib or fixed jib are stored on boom sections, the **backstay straps must be removed if a jib will not be installed.**

2. Lift insert into position in front of adjacent insert.

Lift with chain sling attached to four lifting lugs on insert.

3. Engage fixed horizontal pins (2, View B) in insert with hooked connectors (3) in adjacent insert.

4. Lower insert to horizontal and block under top end of insert.

5. Remove chain slings.

6. Repeat steps 2 – 5 for next insert.

7. Install both bottom connecting pins (4, View C).

**NOTE** On current production cranes, pins (4) are stored in tubes on the butt end of the insert.

8. Repeat steps 2 – 7 for remaining inserts and for boom top.

9. If removed, install lower boom point as follows (View F):

a. Remove pins (8 and 9) from storage position in lower boom point or boom top.

b. Attach slings from assist crane to lower boom point (10).

c. Lift lower boom point into position in front of boom top.

d. Pin to boom top with pins (8). Install cotter pins.

e. Align lugs near bottom of boom point with lugs on boom top.

f. Pin to boom top with pins (9). Install cotter pins.

10. Join bottom connectors between inserts that are not connected (View E):

a. Place blocking under lower boom point sheaves.

b. Attach nylon lifting slings from assist crane to chords at top end of insert nearest butt. **Crane must have capacity to lift 1/2 the weight of assembled boom.**

c. Lift insert until bottom connecting holes line up.

d. Install both bottom connecting pins (4, View C) and safety pin.

e. Remove slings.

### Raise Boom Top Wire Rope Guide

See [Figure 4-44](#), View D for the following procedure.

Wire rope guide (6, View D) on the boom top may be shipped in the stored position as shown in [Figure 4-44](#). If the wire rope guide is stored, proceed as follows:

1. Attach lifting slings from assist crane to wire rope guide.

2. For operation without a luffing jib, remove links and pins from storage (7c, View D).

3. Support wire rope guide so it cannot fall and remove pins (7a) from lugs.

4. Raise wire rope guide (6) to operating position (View D).

5. Install links and pins (7b, View D).

Links (7b) must be installed for operation without a luffing jib. **Otherwise wire rope will rub on boom top.**

**Do not install links (7b) if a luffing jib will be installed.**

6. Pin wire rope guide to boom top with pins (7a).

7. Disconnect lifting slings.

4-178

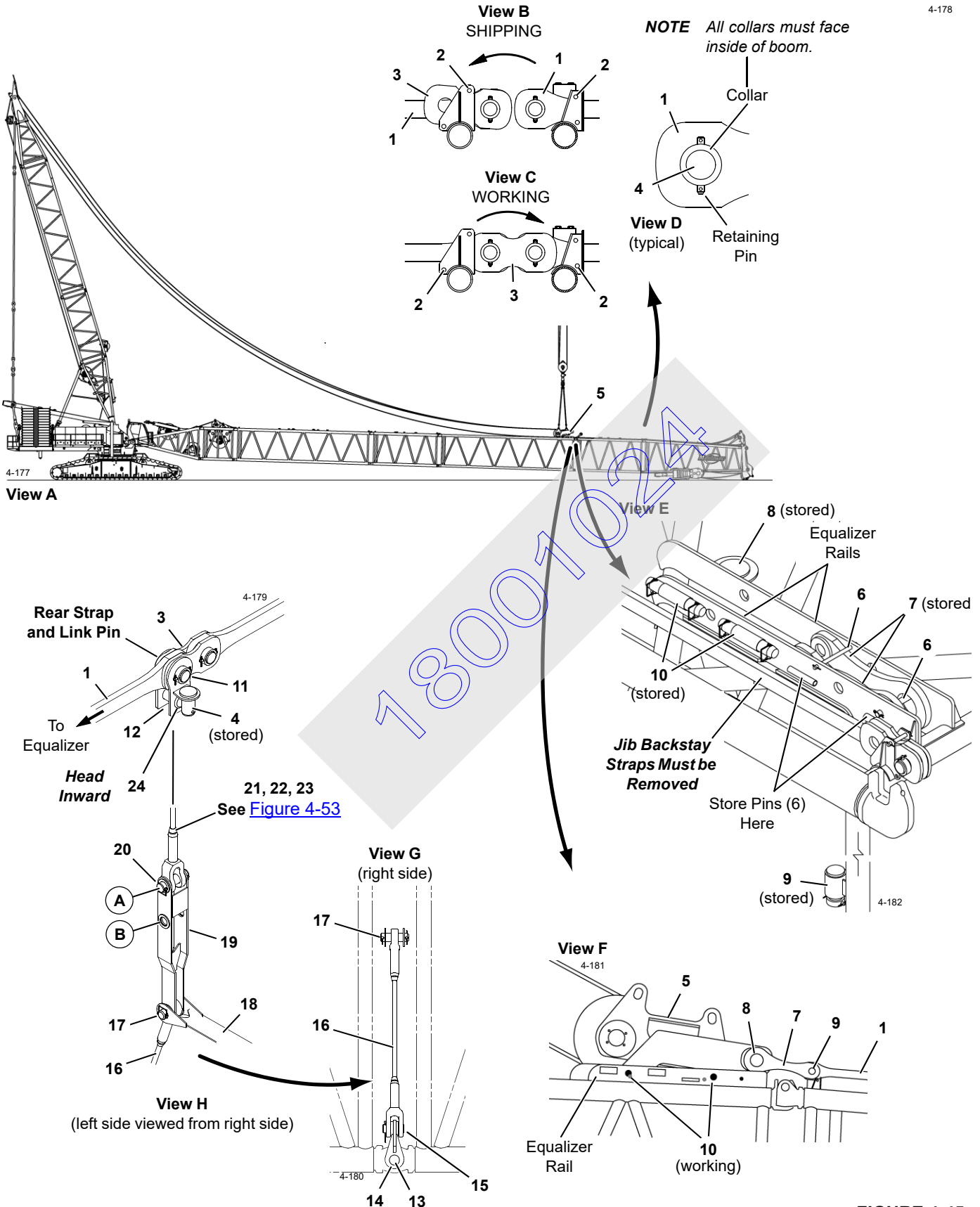

FIGURE 4-45



**Connect Boom Straps — #55-79A Boom**

See [Figure 4-45](#) for the following procedure.

Boom straps and links are shipped in the stored position on the boom sections as shown in View B.

1. Connect straps (1, View B) at top end of each insert, as follows:
  - a. Remove storage pins (2, View B) from shipping position.
  - b. Store pins (2, View C).
  - c. Remove retaining pin (4, View D) from end of each strap (1).
  - d. Rotate links (3, View B) forward and pin to adjacent strap (View C) with connecting pin (4, View D).
2. Connect straps to boom hoist equalizer as follows:
  - a. Remove storage pins (6, View E) securing links (7) to equalizer. Place links to side and store pins (6).
  - b. Using assist crane, lift boom hoist equalizer (5) onto equalizer rails (View A).

**CAUTION**

**Equipment Damage!**

Equalizer rails are provided only to support equalizer during assembly and disassembly.

To prevent structural damage, remove stop pins from equalizer before lifting boom with boom hoist.

- c. Attach equalizer to holes in equalizer rails with stop pins (10, View F). Stop pins are stored in tubes on equalizer rails (View E).

**Stop pins must be installed to prevent equalizer from accidentally sliding back on rails during link assembly.**

- d. Pin links (7, View F) to equalizer (5) with pins (8).

Pins (8) are stored on equalizer rails (View E).

- e. Pin links (7, View F) to straps (1) on adjacent insert with pins (9). Pins (9) are stored in tubes on insert lacing (View E).
- f. Unpin equalizer from rails.

**Install Intermediate Suspension — #55-79A Boom**

See [Figure 4-45](#) and [Figure 4-53](#) for the following procedure.

**NOTE** Intermediate suspension is required at locations specified in Boom Rigging Assembly Drawing.

1. Remove standard connecting pin (4, View D) from **rear holes** in links (3) and strap (1).
2. Using pin (11) — stored in lug on intermediate suspension link (12) — attach strap links (3) and links (12) to strap (1).
3. Store standard connecting pin (4) in lug on link (12) (View H).
4. Remove and store standard removable connecting pin from bottom insert connector ([Figure 4-56](#), View C).
5. Using pin (13, View G), install link (14) and reconnect inserts.
6. Using pin (15), attach pendant (16) to insert link (14) (View G).
7. Using pin (17), attach pendant (16) to connecting link (18) and adjustable link (19), if used (View H).
8. Using pins stored with pendants, pin required pendants to adjustable link (19) or connecting link (18).

**If adjustable link is required, pin pendant to proper holes in link as specified in [Figure 4-32](#).**

9. Repeat steps 1 – 8 on other side of insert.

When boom is raised, boom straps will lift intermediate suspension into position and support inserts.

**Legend for [Figure 4-45](#)**

Item	Description	Item	Description	Item	Description
1	Strap (typical)	10	Stop Pin with Snap Pins	18	Connecting Link
2	Storage Pin with Cotter Pins	11	Strap Pin, 2-1/4 x 5-13/32 in (57 x 137 mm) with Collar, Retaining Pin, and Cotter	19	Adjustable Link
3	Link (typical)	12	Intermediate Suspension Link	20	Pin, 2-1/4 x 8-3/8 in (57 x 213 mm) with Snap Pins
4	#79A Pin, 2-1/4 x 4-1/2 in (57 x 114 mm) with Collar, Retaining Pin, and Cotter	13	Pin, 3 x 10 in (76 X 254 mm) with Safety Pin	21	Pendant, 12 ft, 2-3/4 in (3,7 m)
5	Boom Hoist Equalizer	14	Link	22	Pin, Pendant with Cotter pin
6	Storage Pin with Cotter Pins	15	Pin, Pendant with Cotter pin	23	Pendant, 6 ft (1,8 m)
7	Equalizer Links	16	Pendant, 4 ft, 8 in (1,4 m)	24	Pin, 2-1/4 x 5-3/4 in (57 x 146 mm) with Cotter Pin
8	Pin, 4-1/2 x 6-21/32 in (114 x 169 mm) with Collar, Retaining Pin, and Cotter	17	Pin, 2-1/4 x 7-3/4 in (57 x 197 mm) with Snap Pins		
9	Pin, 2-1/4 x 6-21/32 in (57 x 169 mm) with Collar, Retaining Pin, and Cotter				

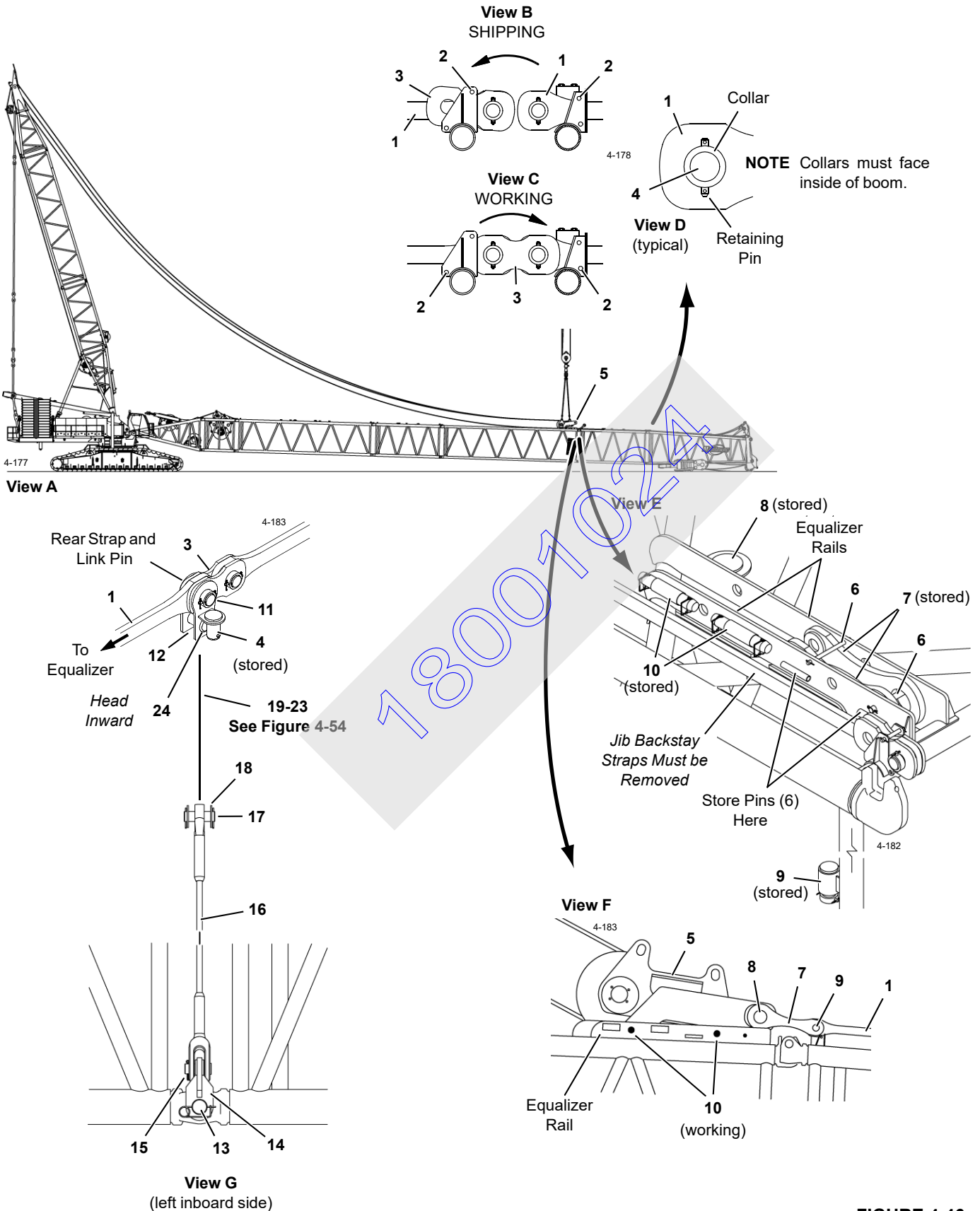

FIGURE 4-46

**Connect Boom Straps — #55 or #55A Boom**

See [Figure 4-46](#) for the following procedure.

Boom straps and links are shipped in the stored position on the boom sections as shown in View B.

1. Connect straps (1, View B) at top end of each insert, as follows:
  - a. Remove storage pins (2, View B) from shipping position.
  - b. Store pins (2, View C).
  - c. Remove retaining pin (4, View D) from end of each strap (1).
  - d. Rotate links (3, View B) forward and pin to adjacent strap (View C) with connecting pin (4, View D).
2. Connect straps to boom hoist equalizer as follows:
  - a. Remove storage pins (6, View E) securing links (7) to equalizer. Place links to side and store pins (6).
  - b. Using assist crane, lift boom hoist equalizer (5) onto equalizer rails (View A).

**CAUTION**

**Equipment Damage!**

Equalizer rails are provided only to support equalizer during assembly and disassembly.

To prevent structural damage, remove stop pins from equalizer before lifting boom with boom hoist.

- c. Attach equalizer to holes in equalizer rails with stop pins (10, View F). Stop pins are stored in tubes on equalizer rails (View E).

**Stop pins must be installed to prevent equalizer from accidentally sliding back on rails during link assembly.**

- d. Pin links (7, View F) to equalizer (5) with pins (8). Pins (8) are stored on equalizer rails (View E).
- e. Pin links (7, View F) to straps (1) on adjacent insert with pins (9). Pins (9) are stored in tubes on insert lacings (View E).
- f. Unpin equalizer from rails.

**Install Intermediate Suspension — #55 OR #55A Boom**

See [Figure 4-46](#) and [Figure 4-54](#) for the procedure.

**NOTE** Intermediate suspension is required at locations specified in Boom Rigging Assembly Drawing.

1. Remove standard connecting pin (4, View D) from **rear holes** in links (3) and strap (1).
2. Using pin (11) stored in lug on intermediate suspension link (12) attach strap links (3) and links (12) to strap (1, View G).
3. Store standard connecting pin (4) in lug on link (12) (View G).
4. Remove and store standard removable connecting pin from bottom insert connector ([Figure 4-56](#), View C).
5. Using pin (13, View G), install link (14) and reconnect inserts.
6. Using pin (15), attach pendant (16) to insert link (14) (View G).

**Legend for [Figure 4-46](#)**

Item	Description	Item	Description	Item	Description
1	Strap (typical)	11	Strap Pin, 3 x 8-1/8 in (76 x 206 mm) with Collar, Retaining Pin, and Cotter Pins	17	Pin, 2-1/2 x 7-5/8 in (64 x 194 mm) with Cotter Pins
2	Storage Pin with Cotter Pins	12	Intermediate Suspension Links	18	Connecting Link
3	Link (typical)	13	Pin, 3-3/4 x 11-3/8 in (95 X 289 mm) with Safety Pin	19	Link
4	Pin, 3 x 6-1/2 in (76 x 165 mm) with Collar, Retaining Pin, and Cotter	14	Link	20	Pin with Cotter Pin (supplied with pendant)
5	Boom Hoist Equalizer	15	Pin with Cotter Pin (supplied with pendant)	21	Pendant, 10 ft, 11 in (3,3 m)
6	Storage Pin with Cotter Pins	16	Pendant, 7 ft, 3 in (2,2 m)	22	Pin with Cotter Pin (supplied with pendant)
7	Equalizer Link			23	Pendant, 7 ft, 3 in (2,2 m)
8	Pin, 4-1/2 x 6-21/32 in (114 x 169 mm) with Collar, Retaining Pin, and Cotter			24	Pin, 2-1/2 x 7-5/8 in (64 x 194 mm) with Collar, Retaining Pin, and Cotter Pins
9	Pin, 3 x 7 in (76 x 178 mm) with Collar, Retaining Pin, and Cotter Pins				
10	Stop Pin with Snap Pins				

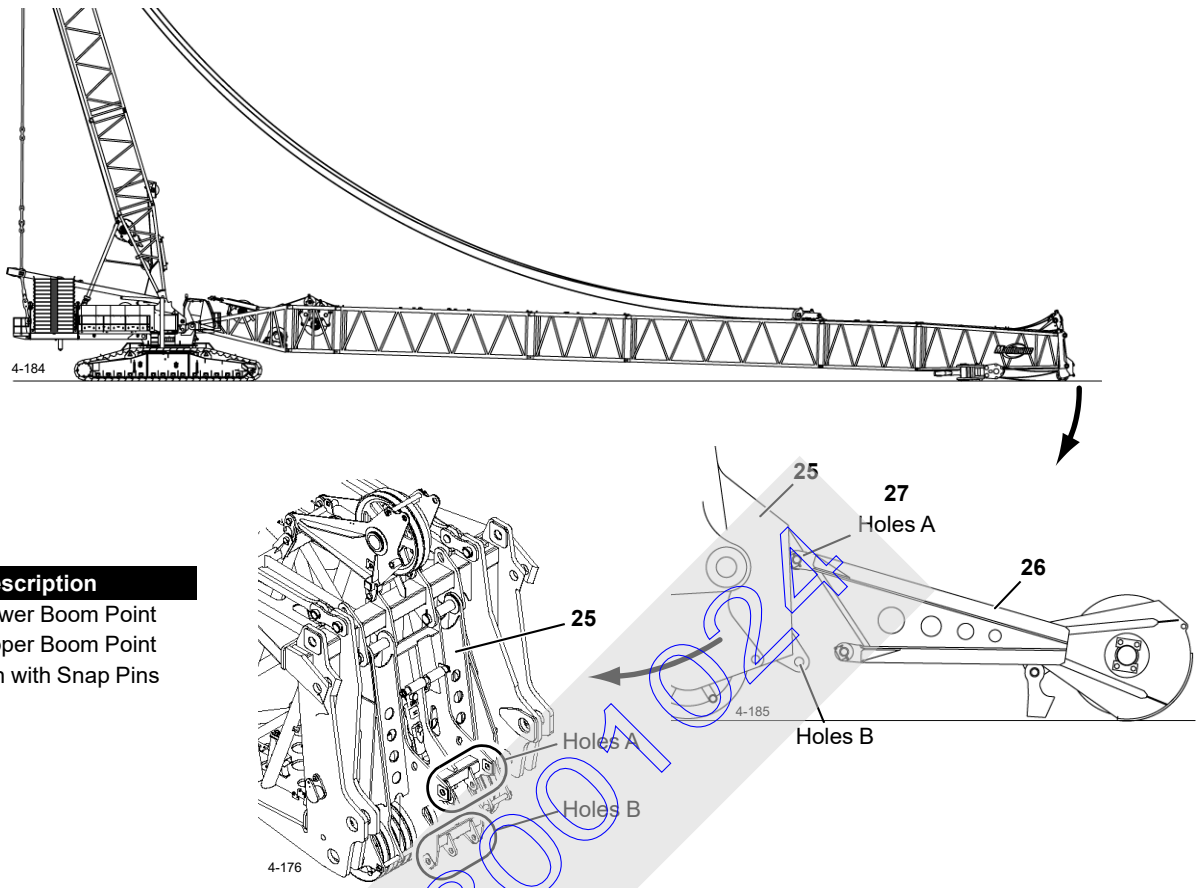

FIGURE 4-47

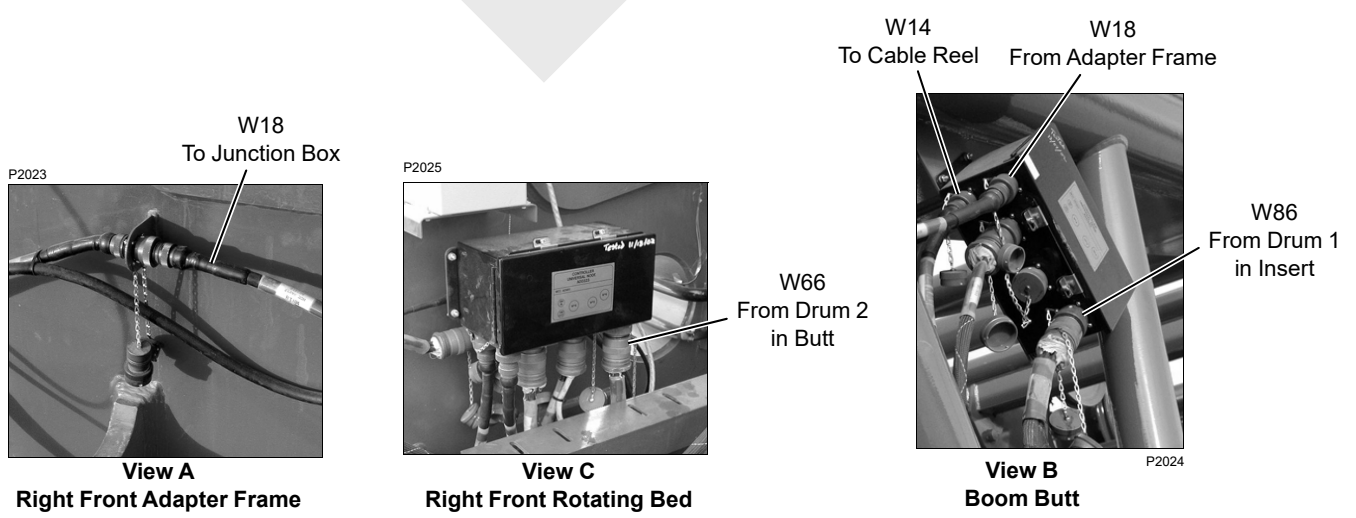

FIGURE 4-48

See [Figure 4-46](#) for the remaining steps.

7. Using pin (17), attach pendant (16) to connecting link (18) and to link (19) or pendant (21, View G) (also see [Figure 4-54](#)).
8. If used, pin pendant (23) to pendant (21).
9. Pin pendant (21 or 23) to links (12).
10. Repeat steps 1 - 8 on other side of insert.

When boom is raised, boom straps will lift intermediate suspension into position and support inserts.

**Install Standard Upper Boom Point**

See [Figure 4-47](#), View C for the following procedure.

Upper boom point cannot be installed if crane will be equipped with a jib (fixed or luffing).

1. Using nylon lifting slings, lift upper boom point (26) into position at lower boom point (25).
2. Remove pins (27) from connecting holes in upper boom point.
3. Align upper connection holes (A) and install pin (27).
4. Rest upper boom point on ground.
5. Remove slings.
6. Install pin (27) in holes (B) as boom is raised.

**Install Extended Upper Boom Point**

See Extended Upper Boom Point Assembly Drawing at the end of this section.

1. Remove lower boom point, as follows:

See [Figure 4-49](#) for the following procedure.

- a. Lower boom until sheaves in lower boom point (2) are just clear of ground.
- b. Attach hooks from assist crane to lifting holes (3) in lower boom point (2).
- c. Remove lower pins (4).
- d. Hoist against lower boom point with assist crane until upper pins (5) are loose and remove upper pins.

- e. Swing lower boom point away from boom top and store.
- f. Store pins (4 and 5) in lower boom point holes.
- g. Lower boom top onto blocking at least 12 in (305 mm) high.

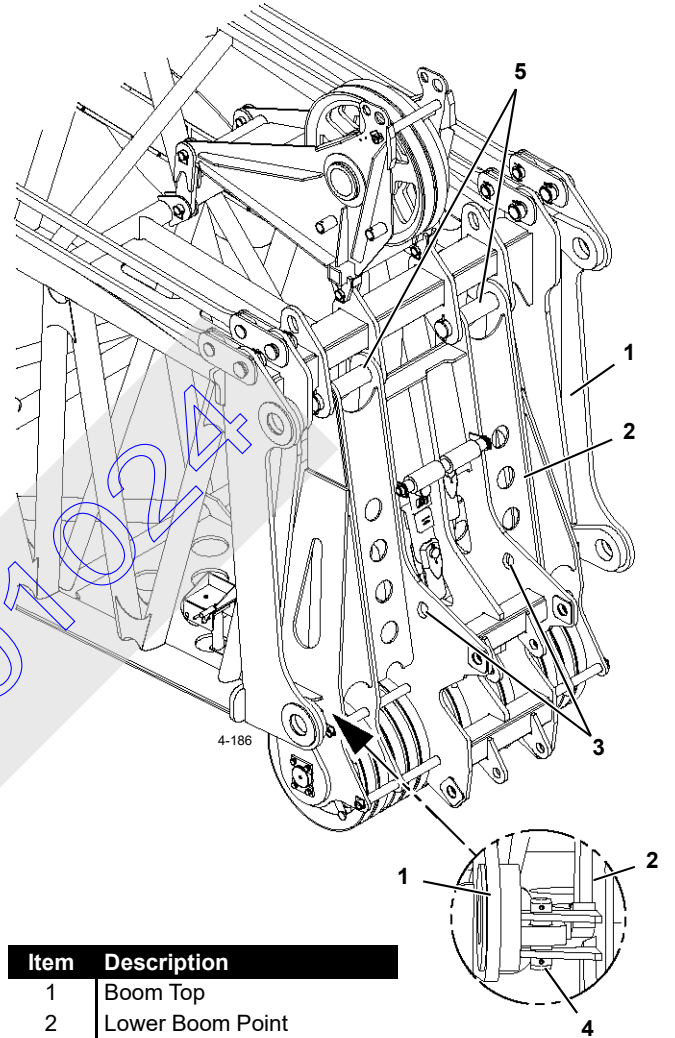

Item	Description
1	Boom Top
2	Lower Boom Point
3	Lifting Holes
4	Lower Pin with Cotter Pins
5	Upper Pin with Cotter Pins

FIGURE 4-49

A15946-2,3,4

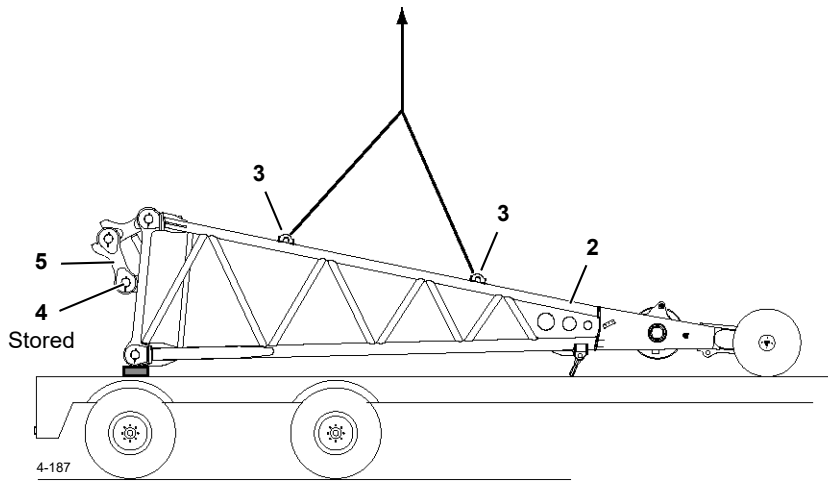

View A

Item	Description
1	Boom Top
2	Lower Boom Point
3	Lifting Lug
4	Pin with Cotter Pins
5	Link
6	Pin with Cotter Pins
7	Roller

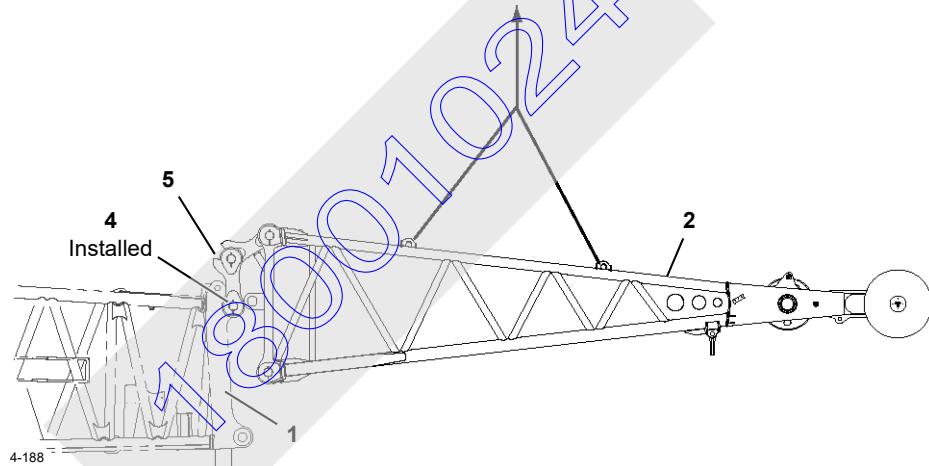

View B

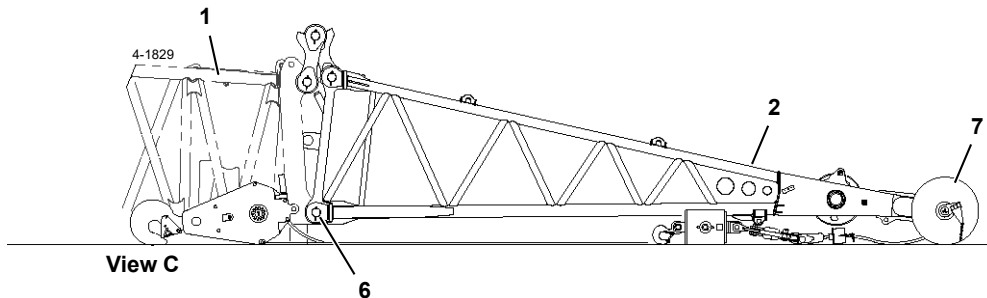

View C

FIGURE 4-50



See [Figure 4-50](#) for the remaining steps.

2. Remove pins (4, View A) to disconnect links (5) from storage position.
3. Allow links to hang down.
4. Attach equal length slings from assist crane to four lifting lugs (3, View A) on extended upper boom point (2).
5. Lift extended upper boom point (2) off trailer and into position at boom top (1, View B).
6. Align connecting holes in links (5, View B) with boom top (1) and install pins (4).
7. Lower extended upper boom point until bottom holes are aligned.
8. Install bottom pins (6, View C).
9. Lower upper boom point until rollers (7, View C) are on ground and disconnect assist crane.
10. As boom is raised, extended upper boom point rollers (7) will roll along ground until links unfold. Upper point will then lift off ground as boom is raised.

***Roller path must be a firm, level surface clear of obstructions.***



## WARNING

### Crushing Injury Hazard!

Prior to raising boom, warn personnel to stand clear of extended upper boom point rollers.

#### ***Install Rated Capacity Indicator/Limiter***

See Boom Limits and Wiring Drawing (at end of this section) for RCL installation. See separate Rated Capacity Indicator/Limiter Operation manual for RCL adjustment and calibration instructions.

#### ***Install Load Line***

See Load Block Reeving instructions in this section for proper routing and reeving of load lines.

#### ***Install Block-Up Limit Control***

See Boom Limits and Wiring Drawing (at end of this section) for block-up limit control installation. See Section 5 of the Service Manual for adjustment instructions.

18001024



Item	Description
1	Transmitter
1a	Hinge — MUST FACE DOWN
1b	Socket-Head Screw, #10 (4)
1c	Washer, #10 (4)
2	Bracket
2a	Large Flange — MUST FACE DOWN
2b	Cap Screw, 3/8 in (4)
2c	Washer, 3/8 in (4)
3	Load Block
4	Mounting Pad (2)

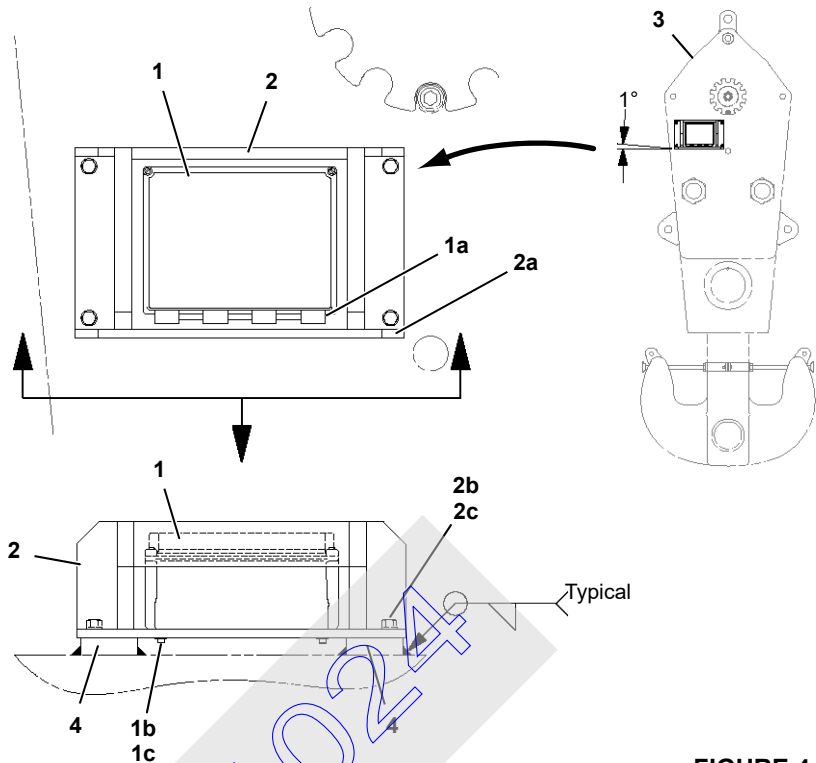

FIGURE 4-51

**Install Block-Level Transmitter**

See [Figure 4-51](#) for the following procedure.

To prevent damage during shipping, the current production block-level transmitter and bracket are shipped in the job box.

The transmitter must be installed on the load block as follows:

1. If not already done, fasten block level transmitter (1) to bracket (2).
2. Fasten bracket (2) to mounting pads (4) on load block (3).
  - Large bracket flange (2a) must face down.
  - Transmitter (1) must be on left side of load block (3) as viewed from the operator's cab once the load block is reeved.
3. Make sure six D-cell batteries are installed in the transmitter. Match the plus and minus of the batteries with the polarity-indicator decals in the holder inside the transmitter.

Mounting pads (4) are pre-installed on load blocks supplied by Manitowoc.

To install the mounting pads on an owner supplied load block, proceed as follows:

1. Locate an area on the side of the load block that has no obstructions between the transmitter and the controller in the boom or jib top.
2. The transmitter must be horizontal plus or minus 1°.
3. Size the weld to match the load block's side plate thickness — not less than 3/16 in (4,8 mm).
4. Use bracket (2) as a guide to locate mounting pads (4).

**Connect Electric Cables**

See [Figure 4-48](#) for the following procedure.

1. If running, **STOP ENGINE before connecting or disconnecting electric cables.**
2. Connect electric cable W18 from junction box to crane connection (View A).
3. Connect the following cables to junction box on boom butt (View B):
  - W18 from adapter frame
  - W86 from Drum 1
  - W14 to cable reel
4. Connect W66 from Drum 2 to junction box on right front of rotating bed (View C).

5. Connect the following electric cables to the appropriate receptacles or junction box:
  - Boom angle indicator
  - Boom point limit switches
  - Automatic boom stop limit switch
  - Block-up limit switches
  - Block-level indicator/transmitter, if equipped

See Boom Wiring and Limits Drawing at the end of this section.

6. If equipped with work lights, move the light in the boom butt from the shipping position to the working position (see [Figure 4-52](#)).

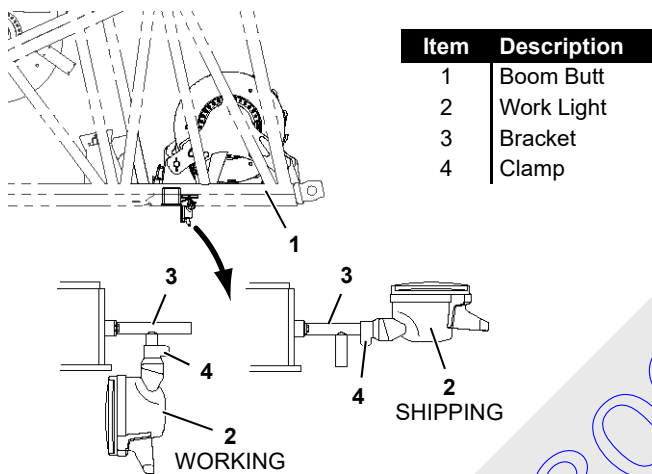

FIGURE 4-52

**Install Wind Speed Indicator Assembly**

Install wind speed indicator if removed for shipping. Use star washers to attach mounting bracket to boom top to provide a good ground (see Wind Speed Assembly drawing at end of this section).

Connect electrical cable at base of wind speed mounting bracket.

**Boom Pre-Raising Checks**

Perform the following pre-raising checks and correct any defects before raising boom.

- Crane on firm, level surface.
- Crawlers blocked if required per Capacity Chart.
- All connecting pins installed and properly retained.
- Boom inserts installed in proper sequence.
- Boom straps installed in proper sequence.
- All jib backstay straps, links, and pins removed from boom sections (if jib will not be used).
- All insert and strap connecting pins installed and properly retained.
- Lower boom point removed if required per Capacity Chart.
- Load lines spooled tightly onto drums and engaged with proper sheaves. Load lines securely anchored to sockets at boom points or at load block and weight ball.
- All blocking, tools, and other items removed from boom.
- Electronic boom angle indicator properly installed and adjusted.
- Block-up limit control properly installed and operational.
- Rated Capacity Indicator/Limiter properly installed and operational.
- Automatic boom stop properly installed. Must be adjusted after boom is raised.
- Physical boom stop operating properly.
- Crane and attachment properly lubricated.
- Wind within allowable limits for operation.

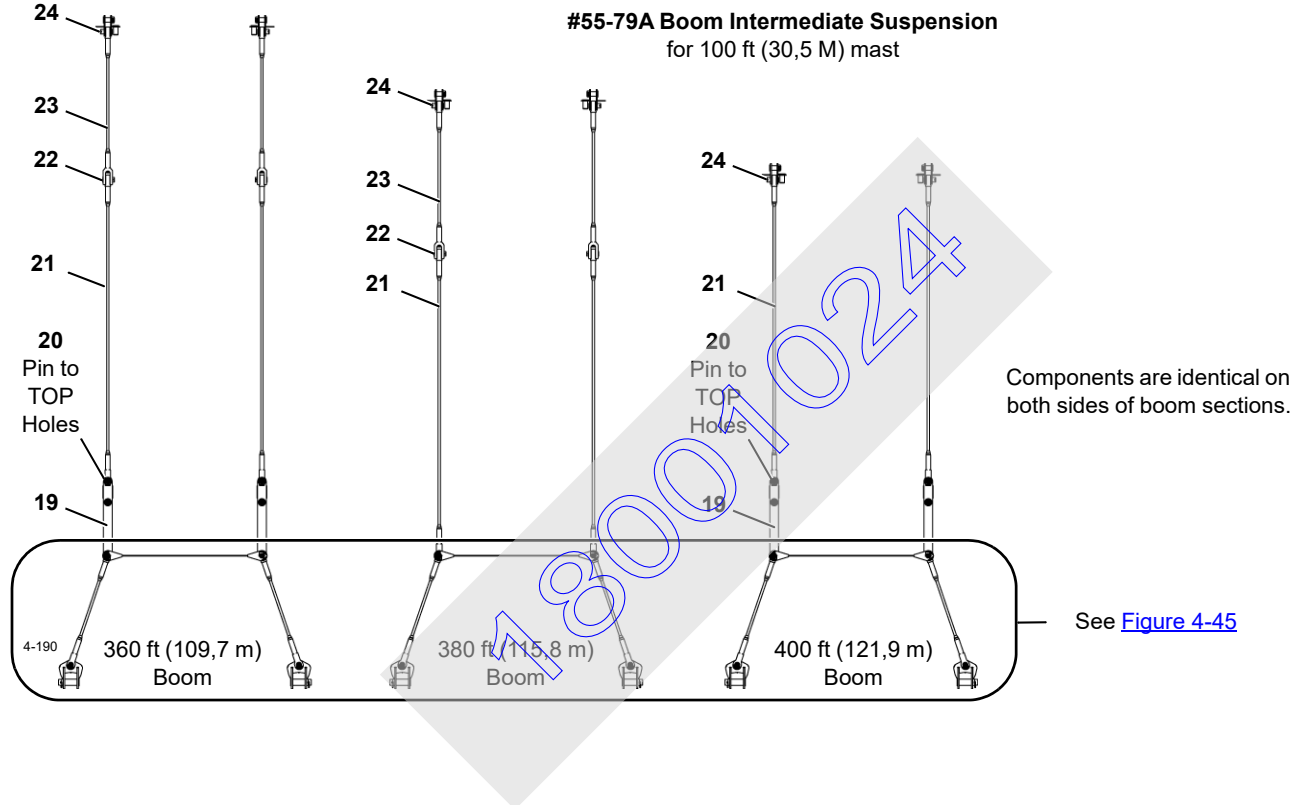

Item	Description	Item	Description
19	Adjustable Link	22	Pin, Pendant with Cotter pin
20	Pin, 2-1/4 x 8-3/8 in (57 x 213 mm) with Snap Pins	23	Pendant, 6 ft (1,8 m)
21	Pendant, 12 ft, 2-3/4 in (3,7 m)	24	Pin, 2-3/4 x 5-3/4 in (70 x 146 mm) with Cotter Pin

FIGURE 4-53

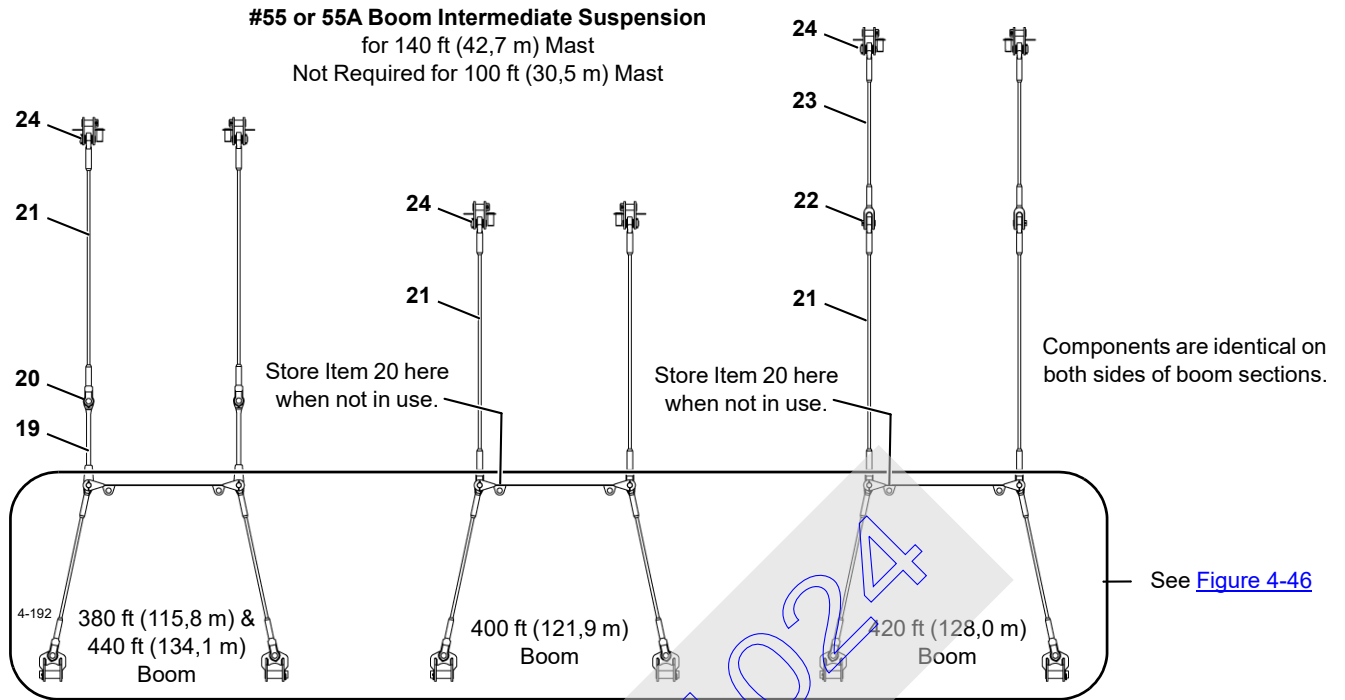

Item	Description	Item	Description
19	Link	22	Pin with Cotter Pin (supplied with pendant)
20	Pin with Cotter Pin (supplied with pendant)	23	Pendant, 7 ft, 3 in (2,2 m)
21	Pendant, 10 ft, 11 in (3,3 m)	24	Pin, 2-1/2 x 7-5/8 in (64 x 194 mm) with Collar, Retaining Pin, and Cotter Pins

Figure 4-54

## Boom Removal

Boom removal is the reverse of installation.



### WARNING

#### Tipping Hazard!

Prevent crane from tipping. Block ends of crawlers, if required per capacity chart, before raising or lowering boom from or to ground.



### WARNING

#### Crushing Injury Hazard!

Boom inserts can collapse when connecting pins are removed. Block both ends of each boom insert before removing connecting pins.

Do not stand on, inside, or under boom inserts during disassembly. Always stand outside boom inserts when removing connecting pins.

Never work under or inside boom inserts that are not securely blocked.

1. Prepare crane and boom as follows:
  - a. Position crane in disassembly area.
  - b. If required per capacity chart, travel front crawler rollers onto blocking (at boom end of crane).  
See Crawler Blocking Diagram in Capacity Chart Manual for blocking requirements.
2. Lower boom to ground as follows:
  - **If equipped with a fixed or luffing jib**, see Jib Rigging Guide for procedure.
  - **If equipped with an standard upper boom point**, remove it before upper point contacts ground. *Upper point cannot support weight of boom.*
  - **If equipped with an extended upper boom point**, make sure ground is clear of obstruction so upper point rollers can roll freely as boom is lowered.
3. Remove standard upper boom point before it contacts ground ([Figure 4-47](#), View C). **Upper point cannot support weight of boom.**

## CAUTION

### Pendant Damage!

Use extreme care while lowering boom equipped with intermediate suspension. Boom straps can land on and crush intermediate suspension pendants.

4. Continue to lower boom onto blocking until boom straps are resting in brackets on boom inserts.  
**Push intermediate suspension pendants to inner side of boom as boom is lowered.**
  5. Remove and store intermediate suspension pendants, links and pins. **Block under inserts before removing lower connecting pins.**
  6. Store insert straps and links.
- NOTE** It is not necessary to remove the boom straps. The straps can be left on the inserts for shipping.
- a. Rotate links at front end of inserts rearward for storage ([Figure 4-45](#) or [Figure 4-46](#) View B).
  - b. Install storage pins (2, [Figure 4-45](#) or [Figure 4-46](#) View B) to secure links and straps.
  - c. Store boom hoist equalizer links on the equalizer rails ([Figure 4-45](#) or [Figure 4-46](#) View E).
7. Disconnect load lines from load block and weight ball and spool load lines onto load drums.
  8. Remove wind speed indicator from jib top to prevent damage during shipping (see Wind Speed Assembly drawing at end of this section).
    - a. Disconnect electrical cable at base of wind speed mounting bracket.
    - b. Remove nuts, star washers, and bolts from base of wind speed mounting bracket.
    - c. Store indicator assembly in a safe place on crane.
  9. Remove fixed jib or luffing jib if installed (reverse assembly steps). The fixed jib or luffing jib backstay straps can be shipped in stored position on boom sections.
  10. Remove extended upper boom point if installed (reverse installation steps).
  11. Store boom top wire rope guide ([Figure 4-44](#), View D).
  12. Store Drum 1 in 10 ft (3 m) insert ([Figure 4-42](#), View A.)
  13. Disassemble boom inserts. Reverse installation steps.

14. Before removing 10 ft (3 m) insert:
  - a. Disconnect hydraulic hoses (8, [Figure 4-43](#), View H1) at connections between insert and boom butt. On current production cranes, store hoses (8, [Figure 4-43](#), View J) in storage brackets (10).
  - b. If equipped, disconnect grease lines between boom sections. Connect grease lines to storage nipples on inserts.
15. Disconnect hydraulic hoses at connections between butt and rotating bed. Do not disconnect hoses for operating boom hinge pins ([Figure 4-43](#), View G).
16. Disconnect boom butt from rotating bed.
17. To operate boom hinge pins:
  - a. Disconnect hydraulic hoses (3a, [Figure 4-43](#), View G1) from couplers (3c) on boom butt.
  - b. Connect hydraulic hoses (3a) to couplers (3b, [Figure 4-43](#), View G2) on rotating bed.
  - c. After boom butt is removed, disconnect hydraulic hoses (3a) from couplers (3b) on rotating bed and connect hydraulic hoses (3a) to couplers (3c, [Figure 4-43](#), View G1) on boom butt. ***This step must be performed to relieve trapped pressure from boom hinge pin cylinders.***
18. Thoroughly clean dust caps and install them over couplers on ends of all hoses.
19. Store the hoses (6a, View F1) in storage brackets (7).

18001024

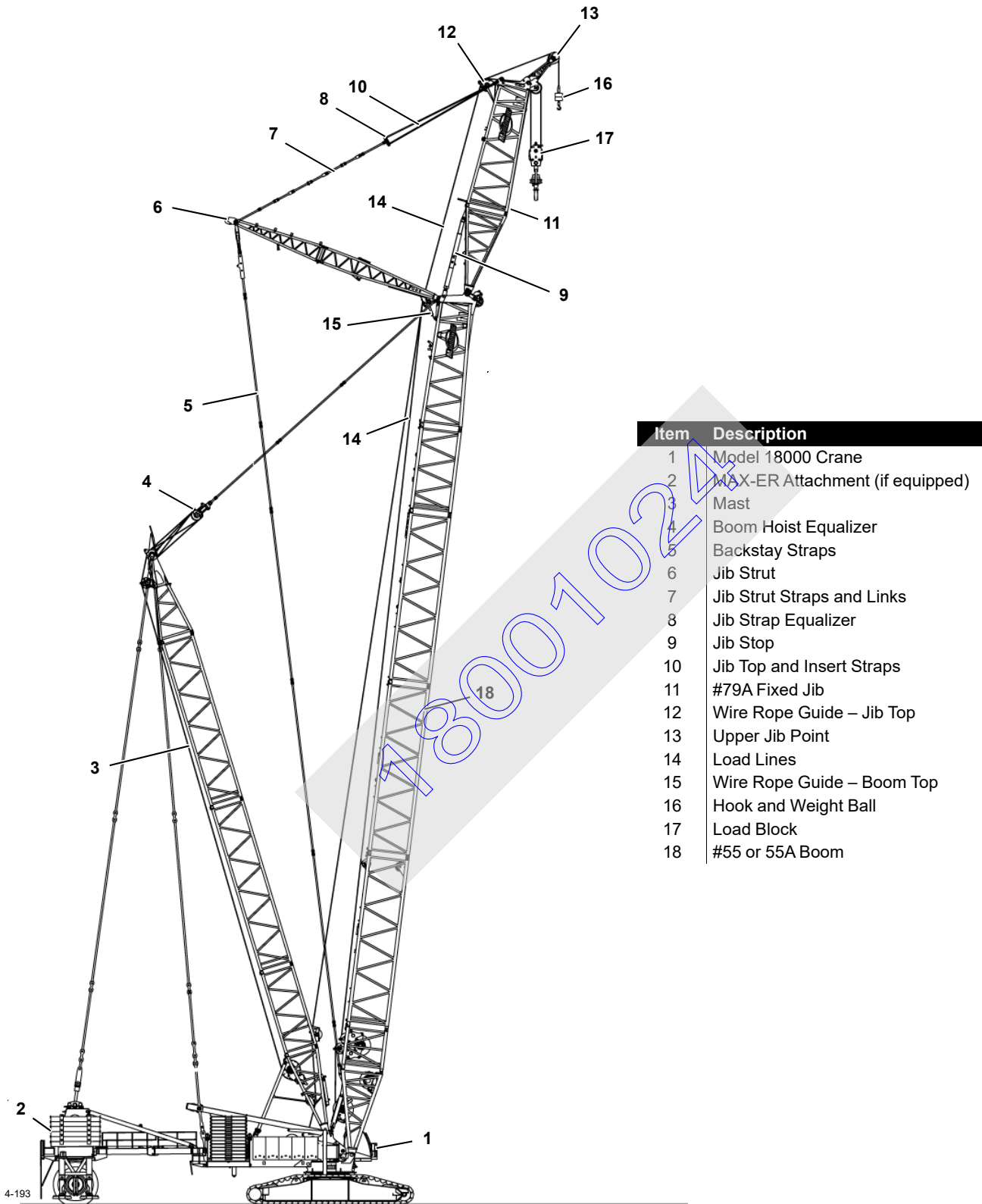

FIGURE 4-55



## Fixed Jib Installation

### General

The following instructions apply to the #79A fixed jib mounted on a #55 or #55A boom (Figure 4-55). For the remainder of this section, fixed jib is referred to as jib or attachment.

As shown on the Fixed Jib Rigging drawing (at end of this section), a 20 ft (6,1 m) butt, 20 ft (6,1 m) and 40 ft (12,2 m) inserts, and a 30 ft (9,1 m) top from a #79A boom can be used to make up the desired jib length.

Operation with the fixed jib attachment requires the following:

- #55 or #55A boom
- 100 ft (30,5 m) mast or 140 ft (42,7 m) mast with wheeled counterweight
- Drum 4 (boom hoist)
- Drum 2 (load drum for lower jib point)
- Drum 3 (load drum for optional upper jib point)

The following instructions assume that the crane is properly assembled with mast and the desired length boom.

A minimum boom length of 140 ft (42,7 m) is required for the jib attachment (see Liftcrane Fixed Jib Capacity charts for boom and jib length limitations).

### Prepare Crane, Boom, and Mast

1. Lower boom to ground level onto blocking approximately 4 ft (1,2 m) high.
2. Remove load block.

3. If installed, remove standard upper boom point.
4. Lower boom point assembly can remain installed on boom top.
5. Connect unused block-up limit electric cords to terminating plugs on boom point junction boxes.

### Install Boom Backstay Straps

See Figure 4-56 for the following procedure.

Starting at butt end of boom, install backstay straps in proper sequence on boom sections according to Fixed Jib Rigging Assembly Drawing. *This step is required only if straps are not stored on boom sections.*

**NOTE** Backstay straps must be removed from boom sections if jib attachment is not used.

To prevent interference between pins, heads of boom strap pins must face outboard sides of boom; heads of backstay strap pins must face inboard.

Connect backstay straps as follows:

1. Remove storage pins from top hole (1A, View A) in brackets (2).
2. Store pins in bottom holes (1B, View B) in brackets (2).
3. Rotate links (3) forward and pin to adjacent straps (4, View B).
4. Retain connecting pins (5, View B) with collars (6, View C) and retaining pins (7).

Item	Description
1A	Storage Pin (strap stored)
1B	Storage Pin (operation)
2	Strap Bracket (typical)
3	Link (typical)
4	Strap (typical)
5	Connecting Pin with Collar and Retaining Pins

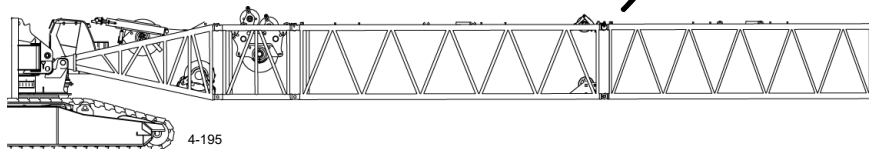
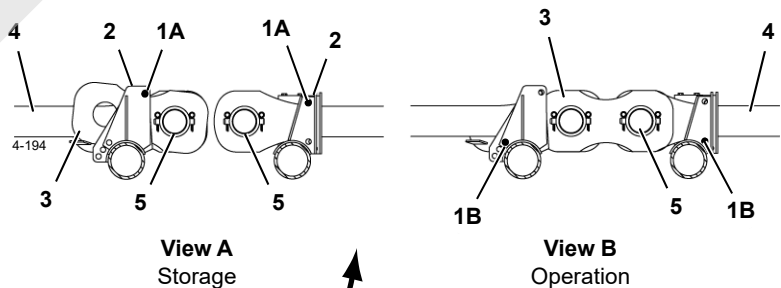
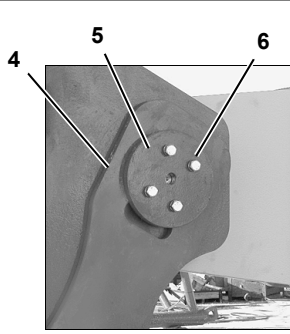
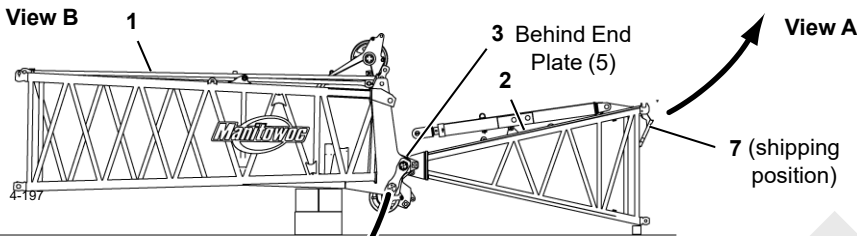
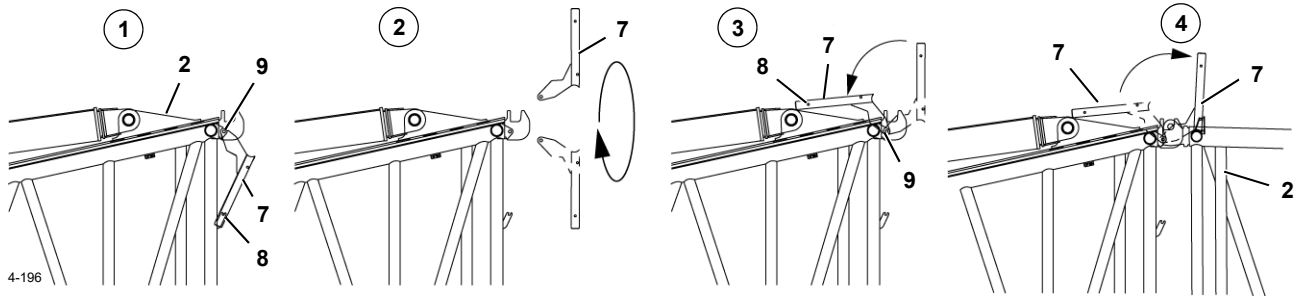
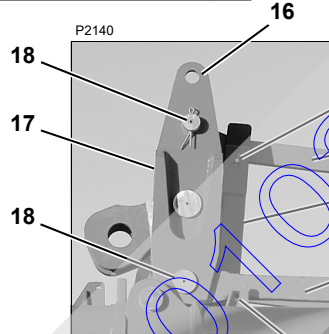

FIGURE 4-56



View D



View C1 (outside of boom)

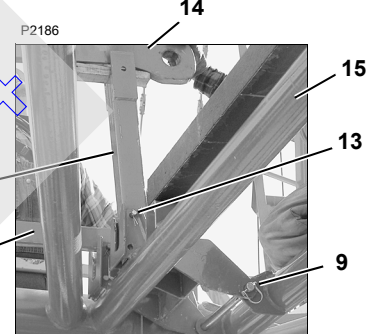

View C2 (inside boom)

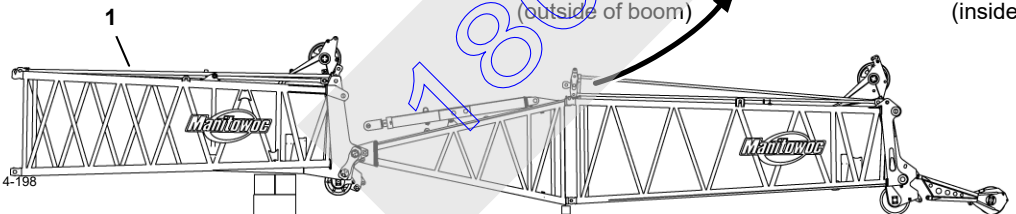

View E

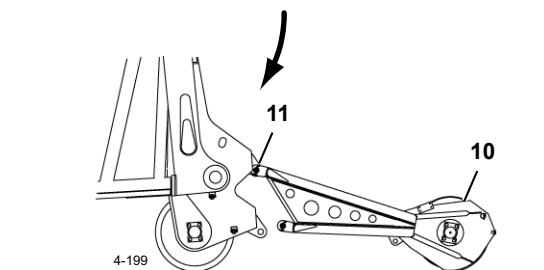

View F

Item	Description
1	#55 or 55A Boom Top
2	#79 or 79A Jib Butt
3	Jib Hinge Pin
4	Keeper Plate
5	End Plate
6	Cap Screws (4 places)
7	Strap Support Bracket
8	Pin
9	Connecting Pin w/Cotter Pin
10	Upper Jib Point Assembly
11	Connecting Pin w/Cotter Pins (2 places)
12	Jib Strap (outside)
13	Strap Shipping Pin
14	Jib Strap (inside)
15	Jib Butt Cross Tube
16	Equalizer Lifting Lug
17	Equalizer
18	Connecting Pin w/Cotter Pin
19	Upper Jib Point

FIGURE 4-57

**Assemble Jib**

See [Figure 4-57](#) for the following procedure.

**NOTE** Jib assembly is identical to boom assembly. In these instructions, it is assumed that assembly personnel already know how to assemble the boom (jib) sections. If in doubt, see Boom Rigging in this section.

See Fixed Jib Assembly drawing for proper positioning of jib sections.

**Install Jib Butt**

1. If necessary, raise boom and block under top approximately 48 in (1,2 m) off ground.
2. Lift jib butt (2) into position at end of boom top (View B).  
Pin jib butt (2) to lugs on boom top (1) with hinge pins (3, View B).
3. Securely fasten keeper plates (4, View D) to pins (3).
4. Attach end plates (5, View D) over ends of pins.
5. Apply Loctite to keeper plate cap screws (6, View D). Securely tighten keeper plate screws. Torque to 100 ft-lb (136 Nm).
6. Lower jib butt onto blocking approximately 6 in (152 mm) high.

**Install Jib Strap Support Brackets**

1. Remove pin (8) securing strap support bracket (7) to jib butt (2) in shipping position (View A1).
2. Remove connecting pin (9) and rotate strap support bracket (7) horizontally 180° (View A2).
3. Repin bracket (7) to jib butt with connecting pin (9) (View A3).
4. Insert pin (8) in top hole of strap support bracket (7, View A3).
5. Temporarily lay strap support bracket (7) back onto jib butt (2) while assembling rest of jib (View A4).
6. Repeat preceding steps for opposite strap support bracket.

**Install Jib Inserts and Top**

1. Determine jib length required for lift to be made.
2. Assemble jib inserts in proper sequence — shortest inserts nearest butt — until all inserts and jib top have been installed.

See Fixed Jib Rigging Assembly drawing for sequence and inserts required.

**Install Upper Jib Point**

1. Lift upper jib point (10, View F) into position at end of jib top.
2. Pin upper point to jib top with pins (11). Pin only top holes at this time. Install retainers.
3. Lower upper jib point to ground.

**Connect Remaining Jib Straps**

**NOTE** This procedure applies only to jibs 70 ft (21,3 m) and longer.

See [Figure 4-56](#), Views A–C for the following procedure.

1. Remove shipping pins (1A, View A) from strap brackets (2) and store as shown (1B, View B).
2. Rotate links (3) forward and pin to adjacent straps (4). Install collars (6), retaining pins (7), and cotter pins.

**Connect Jib Straps to Equalizers**

See [Figure 4-57](#), View C for the following procedure.

1. At butt end of top or insert adjacent to jib butt, remove shipping pin (13) for outside strap (12) from strap bracket.
2. Lift outside strap out of bracket approximately 2 ft (0,6 m).
3. Reinstall shipping pin (13) in strap bracket and lower strap (12) onto pin (View C1).
4. Remove shipping pin for inside strap (14) from inside strap bracket.
5. Lift inside strap (14) approximately 3 ft (0,9 m) out of strap bracket.
6. Rotate strap support brackets (7) forward until they rest on the jib top or insert.
7. Pin strap support bracket (7) to inside strap bracket with inside strap shipping pin (13, View C2).
8. Lower inside strap (14) onto pin (8).
9. Attach sling from assist crane to equalizer lug (16) and lift equalizer (17) into position (View C1).
10. Pin equalizer (17) to inside strap (14) and outside strap (12) with pins (18).

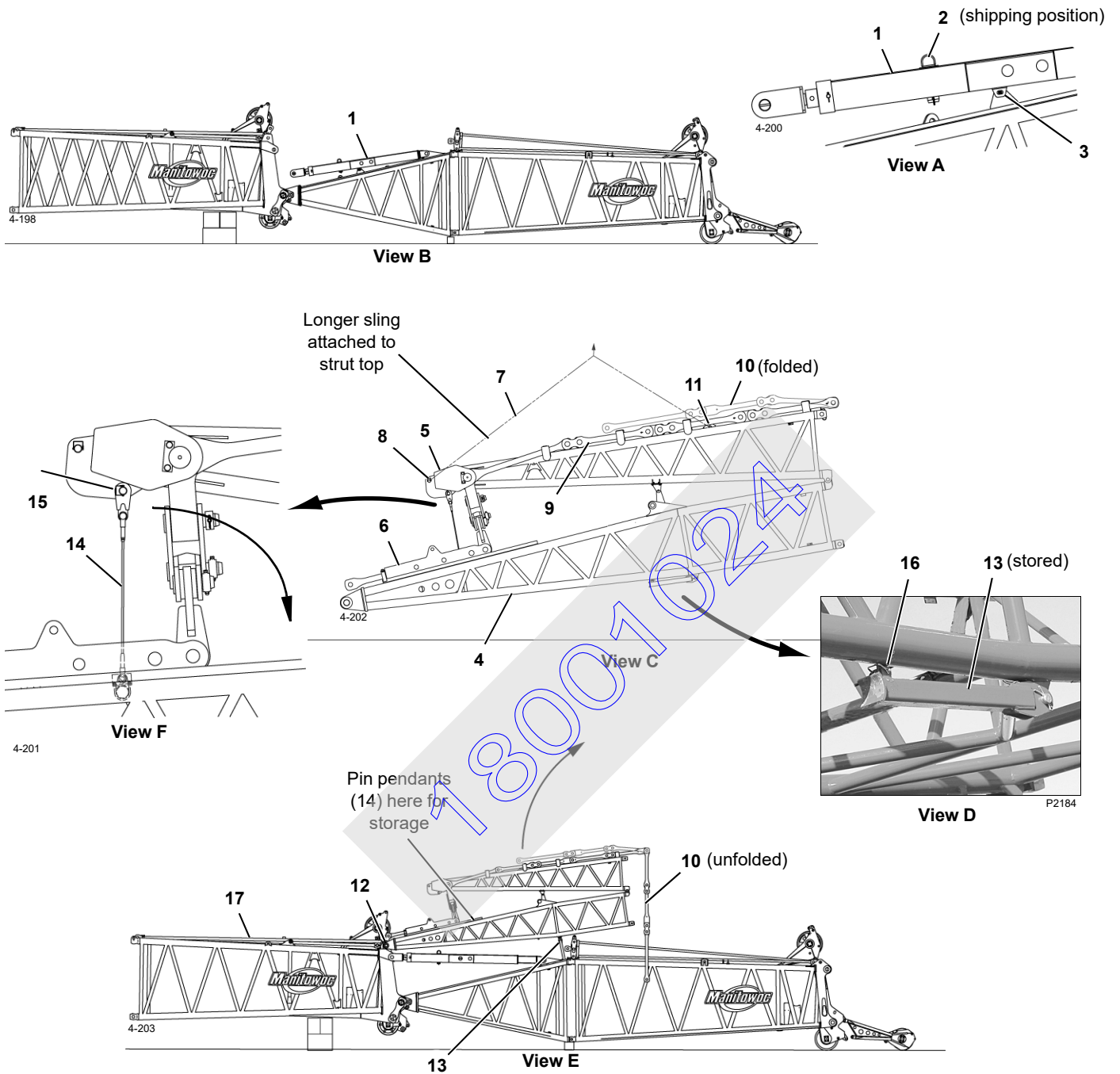

Item	Description	Item	Description	Item	Description
1	Jib Stop	9	Jib Straps and Links (as shipped)	17	Boom Top
2	Stop Pin	10	Jib Straps and Links (assembled)	18	Adjustable Link Strap
3	Pin w/Snap Pin	11	Lifting Lug	19	Strap Retaining Pin
4	Jib Strut Butt	12	Connecting Pin w/Cotter Pins	20	Backstay Strap (#55 Boom)
5	Jib Strut Top	13	Strut Support	21	Strap Connecting Link
6	Adjustable Link	14	3 ft, 3 in (0,99 m) Pendant	22	Connecting Pin w/Collar and Retaining Pins
7	Sling from Assist Crane	15	Pin w/2 Snap Pins	23	Strap Shipping Pin
8	Pin w/2 Snap Pins	16	Pin w/2 Snap Pins		

FIGURE 4-58

**Attach Jib Stop to Boom Top**

See [Figure 4-58](#) for the following procedure.

1. Support jib stop with assist crane.
2. Remove shipping pin (3, View A).
3. Lift jib stop into position and align holes in clevis end with holes in boom top lugs.  
Pin clevis end of jib stop to boom top (View E).
4. Check that stop pin (2) is in shipping position (View A).

**Install Jib Strut**

**! WARNING**  
**Collapsing Strut Hazard!**

To prevent death or serious injury, do not stand on, inside, or under jib strut during assembly. Always stand outside strut when installing connecting pins.

**NOTE** Adjustable link (6) and jib straps and links (9) are shipped at shortest possible length (View C).

See [Figure 4-58](#) for the following procedure.

1. Assemble the jib straps and links in the configuration required for the jib length and offset. See Fixed Jib Rigging Assembly Drawing.
2. Fold links or straps (10) hanging over end of strut top (5) back over top of links and secure in place (View C).
3. Connect shackles and slings (7) from assist crane to jib top pins (8) and lifting lugs (11) as shown in View C.

Butt end of strut butt must be lower than top end to enable connecting jib butt to boom top and to allow jib

support struts (13, View D) to rest on jib butt cross tubes.

4. Lift strut assembly into position at boom top (17, View E) and align connecting holes in strut butt (4) with holes in boom top.
5. Using pins (12, View E), connect strut butt to boom top and install cotter pins.
6. Hold strut supports (13, View D) so they cannot drop, remove shipping pins (16), and lower strut supports to vertical.
7. Lower strut assembly so it rests on strut supports (13) — guide strut supports into position so they come to rest on cross tubes in jib butt.
8. Disconnect slings from strut and remove assist crane.
9. Remove pins (15, View F) from shipping pendants (14).  
Store pendants on jib butt as shown in View E.
10. Unfold overlapped links (10, View E) from top of strut. Allow links to hang down outside of jib.

**Connect Adjustable Links**

See [Figure 4-58](#), View G for the following procedure.

1. Remove retaining pins (19) from adjustable link strap brackets.  
Store pins in storage tubes as shown in View G.
2. Rotate links (21) on boom backstay straps (20) forward.
3. Pin links (21) to straps (18) in adjustable link (6), with pins (22), heads facing out. Retain with collars, pins and cotter pins.

**Do not remove strap shipping pin (23).**

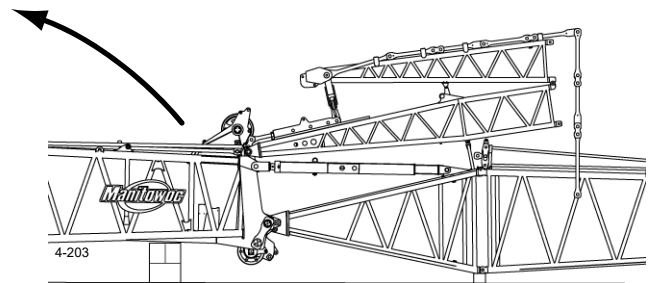
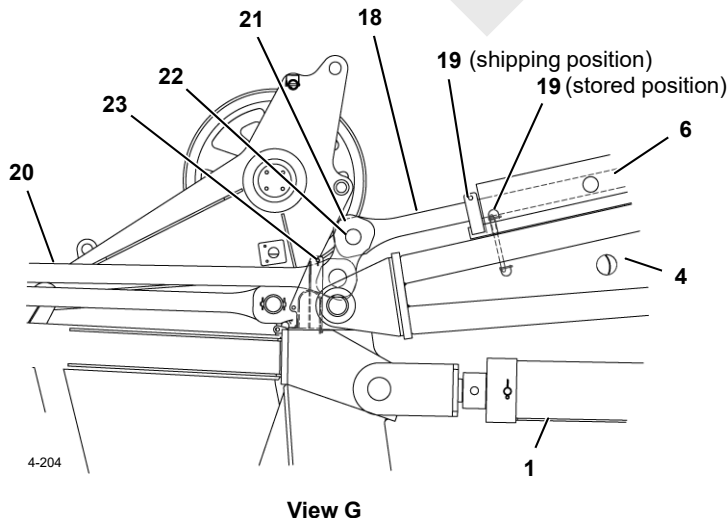

**FIGURE 4-58 continued**



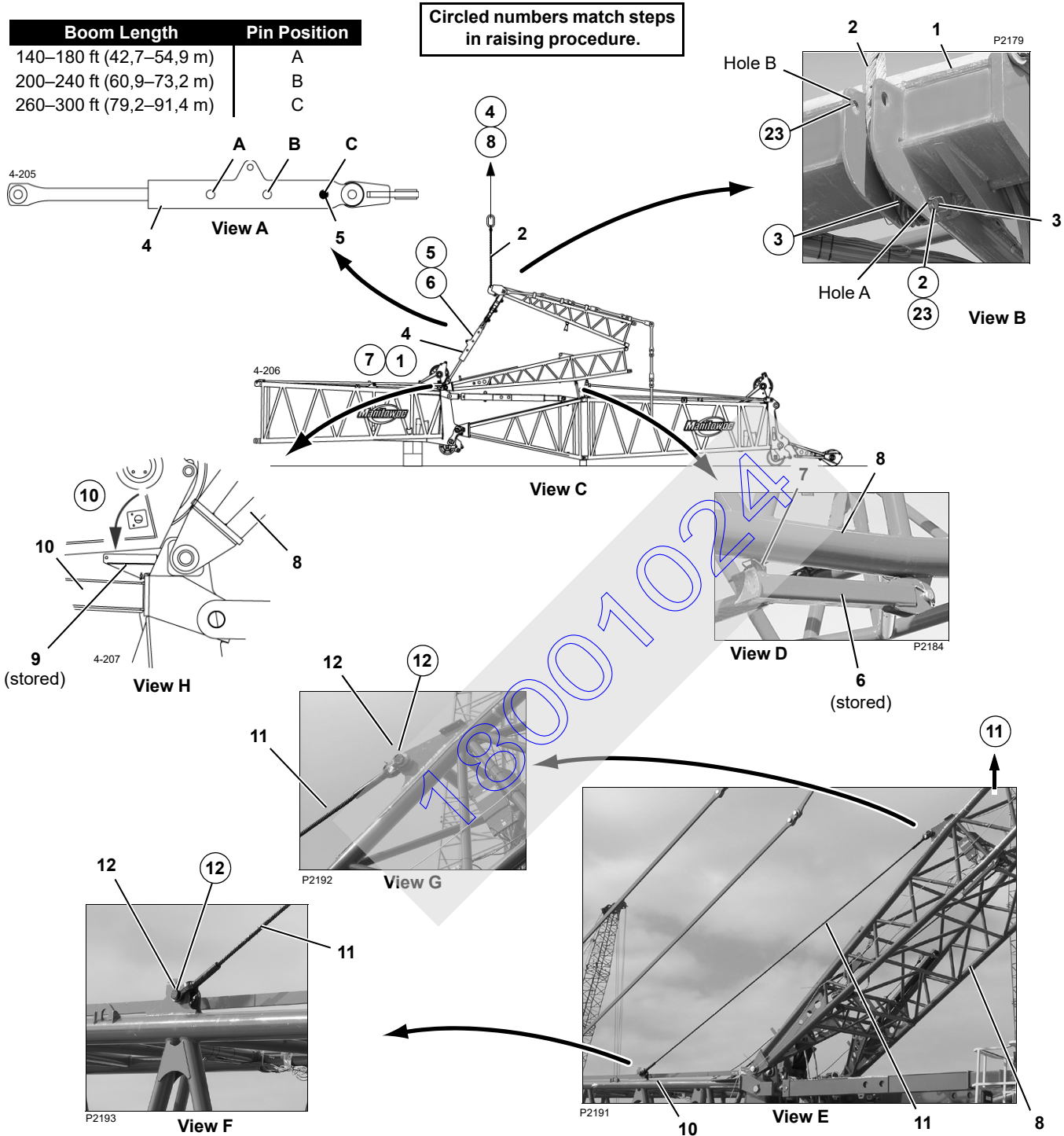

Item	Description	Item	Description
1	Jib Strut Top	7	Pin w/Snap Pin, 3/8 in (10 mm)
2	Sling from Assist Crane	8	Jib Strut Butt
3	Pin w/Snap Pins, 2 in (51 mm)	9	Backstay Strap Bracket
4	Adjustable Link	10	Boom Top
5	Pin w/Cotter Pin, 3 in (76 mm)	11	Pendant, 27 ft, 9-3/8 in (8,47 m)
6	Strut Support	12	Pin w/Cotter Pin

FIGURE 4-59

**Raise Jib Strut**

See [Figure 4-59](#) for the following procedure. Circled numbers in figure match the following steps.

**NOTE** Lifting force required for raising jib strut is approximately 17,000 lb (7 710 kg).

1. Check that strap retaining pin (23) is not stored ([Figure 4-58](#), View G).
2. If necessary, insert pin (3) in Hole A of strut top (1) (View B).
3. Attach sling (2) from assist crane to pin (3) in strut top (View B).
4. Slowly begin raising strut.
5. Observe holes in adjustable links (4) as strut is raised.
6. When holes in adjustable links (4) are aligned to appropriate pin position, insert pin (5).

**NOTE** Pin position is based on boom length. See table in [Figure 4-59](#) for appropriate pinning location.

7. Remove and store strap retaining pin (23, [Figure 4-58](#), View G).

8. Continue raising strut top until strut supports are clear of jib butt.
9. Rotate strut supports (6) to stored position on strut butt (8) and secure with pins (7) (View D).
10. Loosen tie-down bolts on strap brackets (9, View H) at boom top (10).

Rotate brackets to stored position as shown in View H.

---

**CAUTION****Strut/Bracket Damage!**

Strut butt (8) will strike strap brackets (9) when strut is fully raised. Store strap brackets to prevent damage.

11. Continue raising strut until support pendants (11) can be pinned to lugs on boom top and jib butt (View E).
12. Pin pendants (11) to lugs on jib strut butt (8) and boom top (10) (Views F and G).

(Procedure continues on [page 4-113](#))

18001024



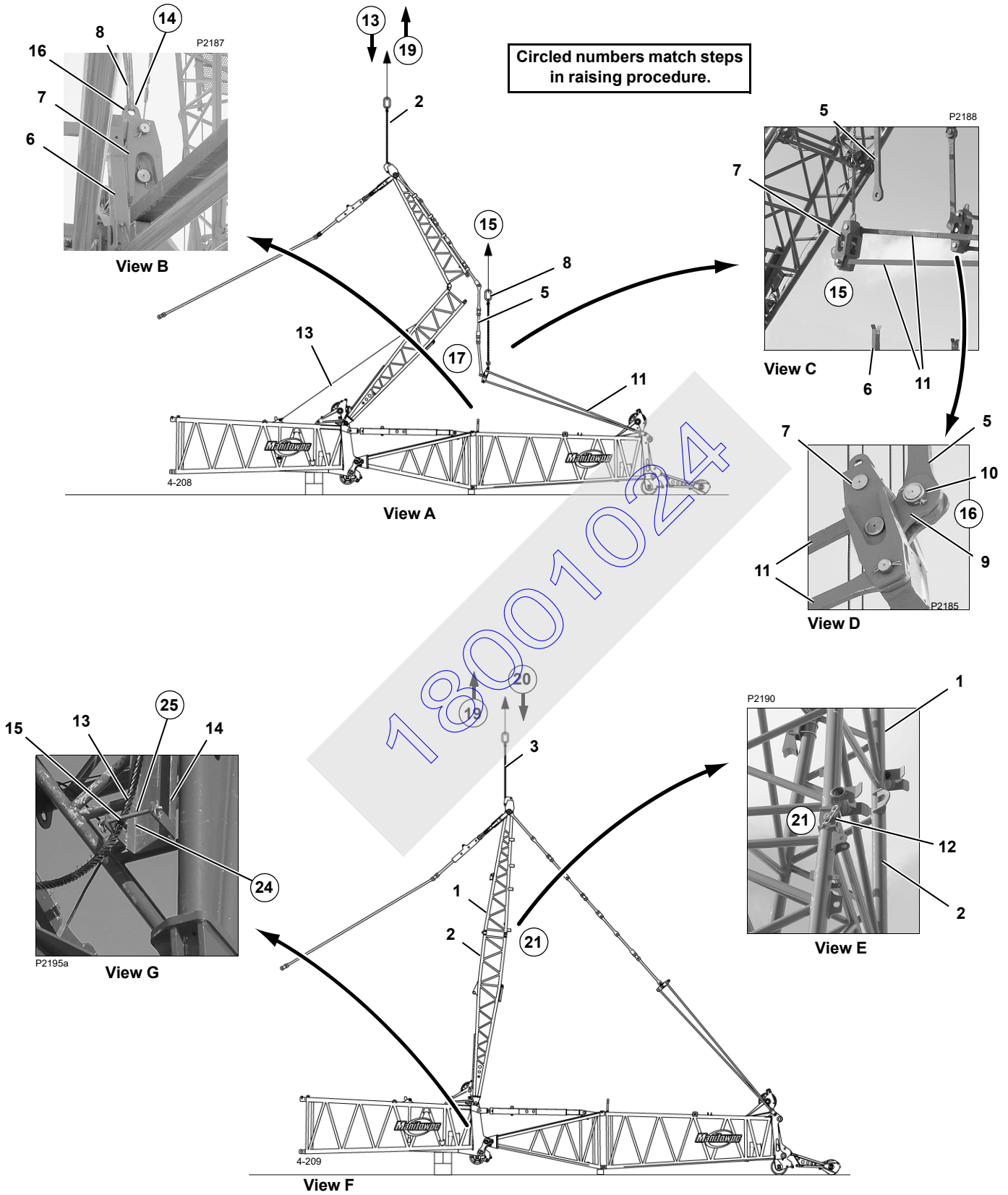

FIGURE 4-60

Legend for [Figure 4-60](#)

Item	Description	Item	Description
1	Jib Strut Top	9	Equalizer Link
2	Jib Strut Butt and/or Strut Insert	10	Connecting Pin w/Collar and Retaining Pins
3	Sling from Assist Crane	11	Jib Straps
4	Adjustable Link	12	Pin w/Snap Pin, 2-1/2 in (64 mm)
5	Jib Straps and Links	13	Support Pendant
6	Strap Support Bracket	14	Strap Bracket
7	Jib Strap Equalizer	15	Pin w/Cotter Pin
8	Lifting Sling	16	Lifting Lug

**Raise Jib Strut (continued)**

See [Figure 4-60](#) for the following procedure. Circled numbers in figure match steps in procedure.

13. Lower jib strut until jib straps and links (5, View A) are directly above equalizer brackets (6) and support pendants (11, View A) are taut.
14. Connect sling (8, View B) from assist crane or other lifting equipment to lifting lug on jib strap equalizer (7).
15. Raise equalizers (7, View C) until straps and links (5) can be connected to equalizer links (9, View D).
16. Pin straps and links (5) to equalizer link (9) using pin (10). Retain pins with collars, pins, and cotter pins (View D).
17. Disconnect lifting sling (8) from equalizer (View A).
18. Repeat steps 14–17 for other equalizer.
19. Continue to raise strut slowly (View F) until connection holes in strut insert and strut butt are aligned.
20. Lower assist crane slightly to close strut joint.
21. Connect strut top (1) to butt (8) using pins (12, View E). Retain pins with snap pins.
22. Disconnect sling (2) from assist crane from strut top.
23. Remove pin (3) from Hole A and insert in Hole B ([Figure 4-32](#), View B).
24. Check that support pendants (13) are inside strap brackets (14).

25. Stow pendants for operation by inserting strap shipping pin (15) into strap bracket (14) as shown in View G.

**Install Jib Load Line**

The Drum 2 load line is used for the lower jib point. This line has multi-part reeving. The Drum 3 load line is used for the upper jib point, if equipped.

See Wire Rope Specifications to determine parts of line required for your job and size load block accordingly. See the Fixed Jib Capacity Charts for capacity limitations.

Route load lines through proper guide sheaves on boom butt, mast, boom top, and jib top. See Load Line Reeving in this section for proper routing and reeving of the load lines.

**Connect Electric Cords**

Connect electric cords to respective junction boxes and switches in boom and jib (see Boom Wiring and Limits Drawing at the end of this section).

Connect all unused electric cords to proper terminating plugs on junction boxes. **Boom will not lower and drums will not hoist if electric cords are not shorted out.**

**Install Wind Speed Indicator Assembly**

Install wind speed indicator if removed for shipping. Use star washers to attach mounting bracket to jib top to provide good a ground (see Wind Speed Assembly drawing at the end of this section).

Connect electrical cable at base of wind speed mounting bracket.

## Jib Removal

### Disconnect Electric Cords

Disconnect remaining electric cords from respective junction boxes and switches. Install terminating plugs on junction boxes.

### Remove Wind Speed Indicator Assembly

Remove wind speed indicator from jib top to prevent damage during shipping (see Wind Speed Assembly drawing at end of this section).

1. Disconnect electrical cable at base of wind speed mounting bracket.
2. Remove nuts, star washers, and bolts from base of wind speed mounting bracket.
3. Store indicator assembly in a safe place on crane.

### Remove Jib Load Lines

1. Remove load blocks and weight balls.
2. Remove block-up limit weights and chains.
3. Spool load lines onto Drums 2 and 3.

### Lower Jib Strut

Unless otherwise specified, see [Figure 4-60](#) for the following procedure.

1. Connect sling from assist crane to jib top as shown in View F. Pin (3, [Figure 4-59](#), View B) must be in Hole B for lowering strut.
2. Remove strap shipping pins (15, View G) from strap brackets (14).
3. Remove front connecting pins (12, View E).
4. Slowly hoist with assist crane until front joint between strut top and strut butt opens.
5. Slowly pay out assist crane load line to lower strut.
6. Stop when support pendants (13, View A) are taut.  
Jib strap equalizers (7, View C) will be above strap support brackets (6) as shown in View A.
7. Connect sling (8, View C) from assist crane or other lifting device to jib strap equalizer (7).
8. Remove pin (10, View D) from link (9).
9. Lower equalizer (13) until it rests on support bracket (12) as shown in [Figure 4-59](#), View H.

10. Disconnect lifting sling (8) from equalizer (13).

11. Repeat steps 7–10 for other equalizer.

See [Figure 4-59](#) for the remaining steps.

12. Disconnect and store support pendants (11, Views F and G)

13. Continue lowering strut until strut butt is approximately 2 ft (0,6 m) above jib butt.

Guide jib straps and links (11) outside of jib as strut is lowered as shown in View C.

14. Remove pins (7, View D) and allow strut supports (6) to hang down from jib butt.

Return pins to lugs on jib butt for storage.

15. Loosen tie-down bolts on boom top backstay strap brackets (9, View H) and rotate brackets up to working position.

Tighten tie-down bolts.

16. Continue to slowly lower strut.

Guide boom backstay straps into boom backstay strap brackets while lowering strut.

Stop when straps are resting in strap brackets as shown in [Figure 4-58](#), View G.

17. Remove pin (5, View A) from adjustable links (4).

18. Continue lowering strut to compress adjustable links (4, View A).

Stop when pins (5) can be inserted in holes (Position C).

19. While continuing to slowly lower strut, guide strut supports (6) to rest on jib butt cross tubes.

See [Figure 4-58](#) for the remaining steps.

20. Remove pendants (14) from stored position on jib butt (View E).

21. Attach pendants (14) to strut top as shown in View F.

22. Remove pins (19, View G) from stored position and insert into adjustable link supports to secure straps.

23. Remove and store jib straps and links (10, View E).

**NOTE** It is not necessary to fold straps and links (10) over top of strut top as shown in View C.

24. Pin jib links and straps shipped with strut top (10, View C) in shortest possible length for shipping.

**Disconnect Jib Straps**

Reverse steps under Connect Jib Straps topic ([page 4-107](#)).

**NOTE** Disconnecting jib straps is not necessary if jib is not being prepared for shipping.

**Remove Jib Inserts and Top**

Reverse steps under Install Jib Inserts and Top topic ([page 4-107](#)).

**Store Jib Strap Support Brackets**

Reverse steps under Install Jib Strap Support Brackets topic ([page 4-107](#)).

**NOTE** Storing support brackets is not necessary if jib is not being prepared for shipping. Lay brackets (7) back onto jib butt as shown in [Figure 4-57](#), View A4 and tie down before removing jib butt.

**Remove Jib Butt**

Reverse steps under Install Jib Butt topic ([page 4-107](#)).

18001024

*THIS PAGE INTENTIONALLY LEFT BLANK*

18001024

## WIRE ROPE INSTALLATION

**NOTE** Wire rope manufacturer's recommendations take precedence over information in this section.

### Wire Rope Storage

Store wire rope in coils or on reels off the ground or floor in a clean and dry indoor location. If outdoor storage is necessary, wire rope must be covered with a protective wrapper. Keep wire rope away from acids, fumes, and other corrosives. Keep wire rope away from heat that can dry out the lubricant. If the storage period will be long, lubricate wire rope and perform periodic inspection given in this section at least monthly.

### Removing Wire Rope from Shipping Reel

#### CAUTION!

##### Wire Rope Damage!

Shipping reel must rotate when wire rope is unwound. Attempting to remove wire rope from a stationary reel can result in a "kinked" wire rope, and wire rope will be ruined.

1. Mount wire rope shipping reel on a shaft supported at both ends by jacks or blocks as shown in [Figure 4-61](#).

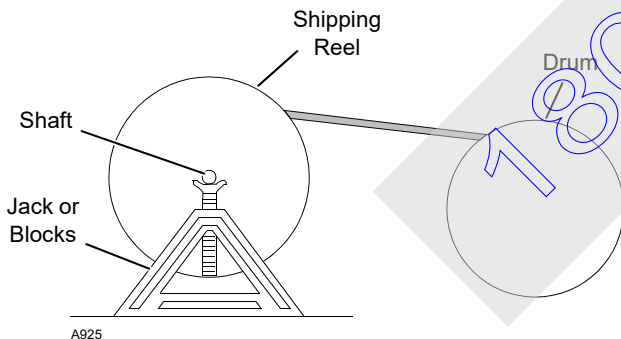

FIGURE 4-61

2. Provide a brake at shipping reel (see [Figure 4-62](#)) so wire rope can be wound tightly onto drum.

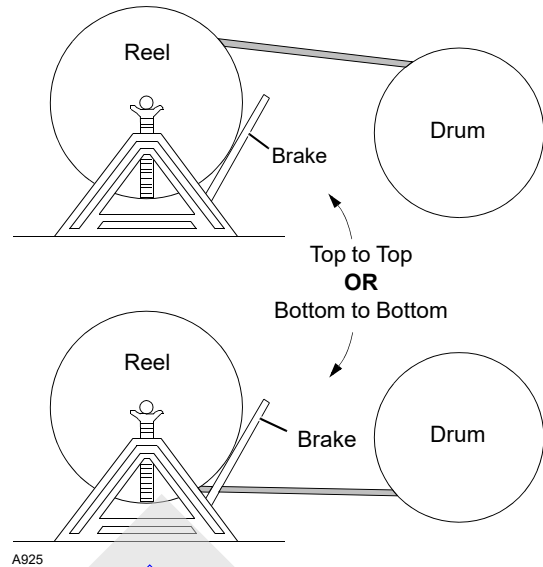

FIGURE 4-62

3. Avoid a reverse bend when winding wire rope onto drum: wind from top of reel to top of drum or from bottom of reel to bottom of drum as shown in [Figure 4-62](#).
4. Avoid dragging wire rope in dirt or around objects that can scrape, nick, cut, or crush wire rope.

### Seizing and Cutting Wire Rope

Apply tight seizings of annealed wire to the ends of all wire rope. If not done, the rope wires and strands may slacken. This action will result in overloading of some strands and underloading of others. Bird caging and breakage of the wire rope can occur.

Before cutting wire rope, apply seizings on both sides of the point where the cut will be made. Then cut the wire rope with a torch, rope cutter, or abrasive cut-off wheel.

See [Figure 4-63](#) for:

- Number of seizings to be applied to the ends of wire rope and to both sides of the point where a cut will be made
- Proper application method: each seizing should be one rope diameter long.

Wire Rope Type	Seizings Required
Preformed	1
Non-preformed	3

Place free end of seizing wire in valley between two stands. Then wind seizing wire over free end as shown. Finally, twist and pull two ends of seizing wire together until seizing is tight.

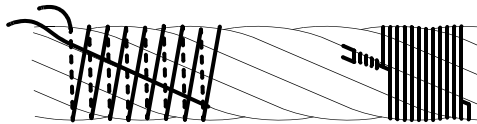

**View A** Rope Diameter 1 in (26 mm) and Larger

Wind seizing wire around wire rope as shown. Then twist two ends of seizing wire together at center of seizing. Alternately twist and pull ends until seizing is tight.

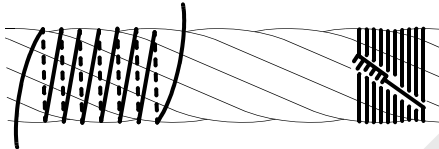

**View B** Rope Diameter Smaller than 1 in (26 mm)

A925

**FIGURE 4-63**

### Anchoring Wire Rope to Drum

See [Figure 4-64](#) for the following procedure.

Use the correct wedge part number for the size of wire rope being used (see parts drawing for the boom hoist drums or for the load drum shaft to obtain the correct part number).

1. Assemble wire rope and wedge to drum socket.
2. Tighten wedge, rapping back of wedge with a brass drift pin and hammer.

### **! WARNING!** Falling Load Hazard!

Wire rope can be pulled out of drum if the following steps are not taken.

- Install straight wedge so corrugated side is against wire rope.
- Install wedge so end of wire rope extends past end of wedge, but not out of drum socket.
- Make sure seizing is not under wedge. Remove seizing if it interferes with assembly.

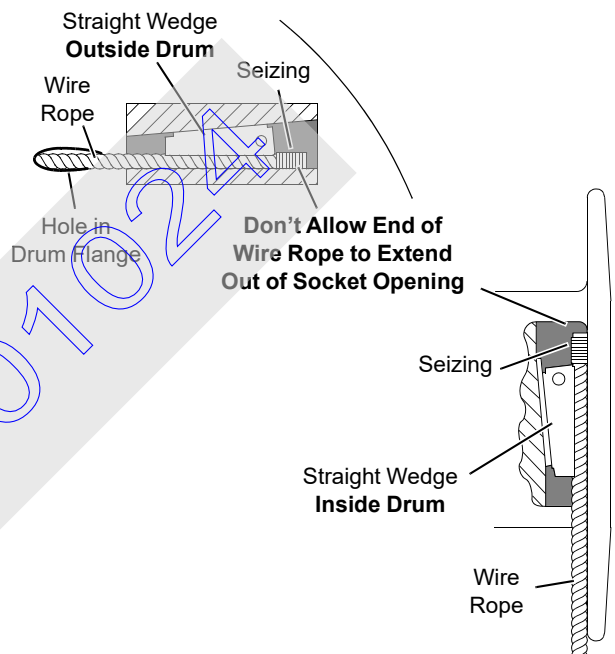

**FIGURE 4-64**

### Winding Wire Rope onto Drum

See Drum and Lagging Chart in Capacity Chart Manual for correct size of drum laggings, if used.

See Wire Rope Specifications Chart in Capacity Chart Manual for correct type, size, and amount of wire rope to be installed on load drums.

See Boom Rigging Drawing at the end of this section for correct type, size, and amount of wire rope to be installed on boom hoist drums.

1. Carefully inspect drums and all rope guides, rollers, and sheaves for defects that can cause wire rope to wear or be cut. If defects cannot be fixed, replace faulty parts.



- Apply tension to wire rope as it is wound slowly onto drum.

First wrap must be tight against drum flange for approximately three-fourths of drum diameter (see [Figure 4-65](#)).

- Tap adjacent wraps against each other with a soft metal or wooden mallet.

Use extreme care not to put twists or turns in wire rope; allow rope to assume its natural lay.

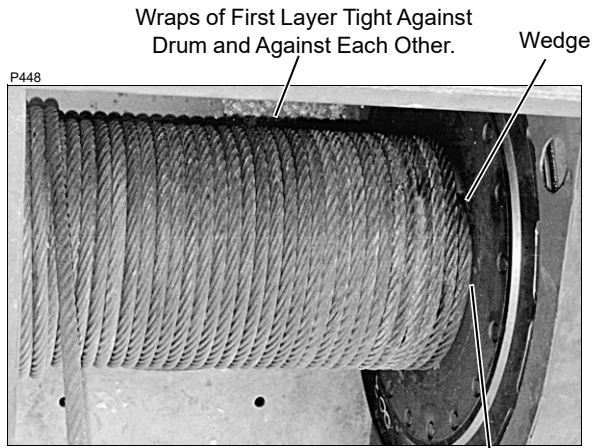

View A

First Wrap Tight Against Flange for 3/4 of Diameter.

Voids and Loose Wraps in First Layer Cause Severe Wear of Wire Rope.

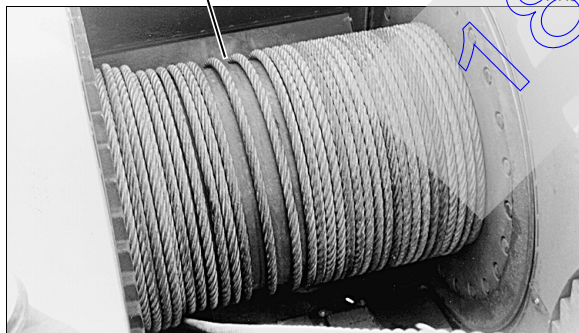

View B

FIGURE 4-65

**CAUTION!**

**Wire Rope Damage!**

Voids or spaced wraps in first layer (see [Figure 4-65](#), View B) will permit movement and a wedging action with subsequent layers. Wedging action will cause crushing and abrasion of wire rope.

Never allow wire rope to “cross wind” on drums.

**Anchoring Wire Rope to Socket And Wedge**

**! WARNING**  
**Falling Load Hazard!**

- Inspect all parts prior to use. Do not use parts that are cracked or otherwise defective.
- Remove minor nicks, burrs, or rough edges from socket, wedge, or pin by lightly grinding. Do not reduce original dimensions by more than 10%.
- Do not reinstall shipping material (bolt, plastic strap or wire) in hole of wedge or socket after assembling. Discard these materials because they can prevent wedge from tightening in socket.
- Only use a wedge and socket which are correct size for wire rope being used. Do not mix and match parts from one assembly with parts from another assembly. Terminator socket and wedge has “go” and “no-go” holes to check for proper rope size.
- Attach wire rope clip to dead end of wire rope after assembling wire rope to wedge and socket.

See [Figure 4-66](#) for the following procedure.

- Assemble wire rope and wedge to socket so live end of wire rope is in a straight line with socket pin hole. **Do not assemble WRONG as shown.**
- Allow dead end of wire rope to extend past end of socket amount shown.
- Allow wire rope to assume its natural lay.
- Pull against wedge and live end of wire rope enough to tighten wedge in socket.

Use a brass hammer to seat wedge and wire rope as deep into socket as possible.

- Attach a wire rope clip to dead end of wire rope using one of the RIGHT methods shown. Rope clip will aid in preventing wire rope from being pulled out of socket.

**NOTE** Use Right Method A only if wire rope clip is small enough to be securely tightened to dead end. Right Method C is only for a terminator wedge socket.

- After socket is pinned in place, hoist load slowly so wedge seats tight. Do not shock load socket and wedge.

**WARNING**  
**Falling Load Hazard!**

Wire rope can break if the following precaution is not observed:

- Do not attach dead end of wire rope to live end of wire rope with wire rope clip. Wire rope clip will transfer load from live side of wire rope to dead end, seriously weakening attachment.

**T (Rope Clip Nut Torque)**

inch (mm)	Wire Rope/Clip Size			
	7/8 (22,23)	1 (25,4)	1-1/8 (28,58)	1-1/4 (31,75)
<b>Torque</b>				
* ft/lbs (kN/m)	225 (0,30)	225 (0,30)	225 (0,30)	360 (0,49)

\* Tightening torque values shown are based on threads being clean, dry and free of lubrication.

**TL (Tail Length)**

**Standard 6 to 8 Strand Wire Rope**

Minimum of 6 rope diameters, but not less than 6 in (152 mm).

**Rotation Resistant Wire Rope**

Minimum of 20 rope diameters, but not less than 6 in (152 mm).

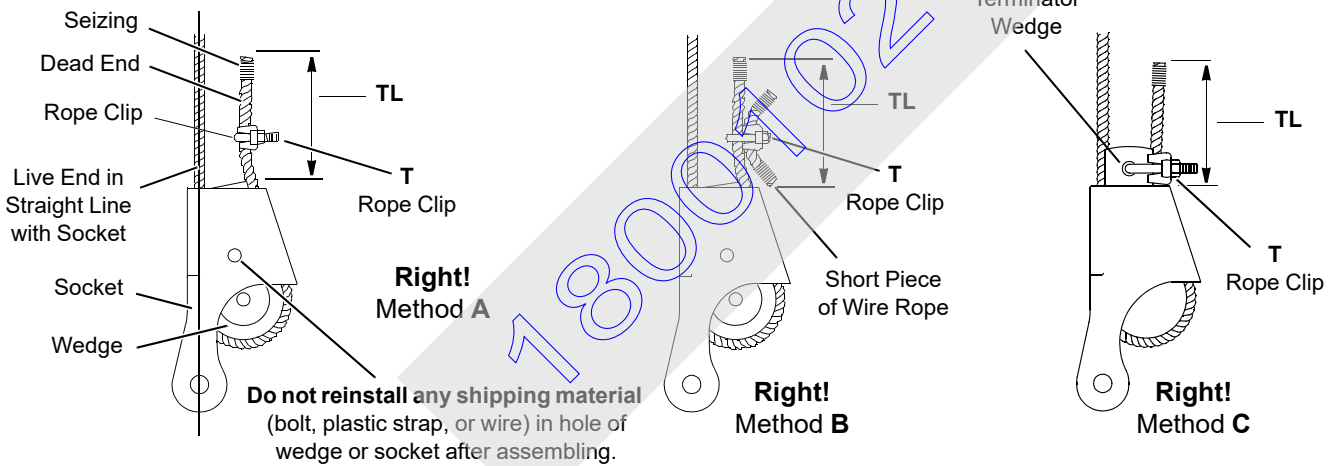

**ALL ARE DANGEROUS AND PROHIBITED!**

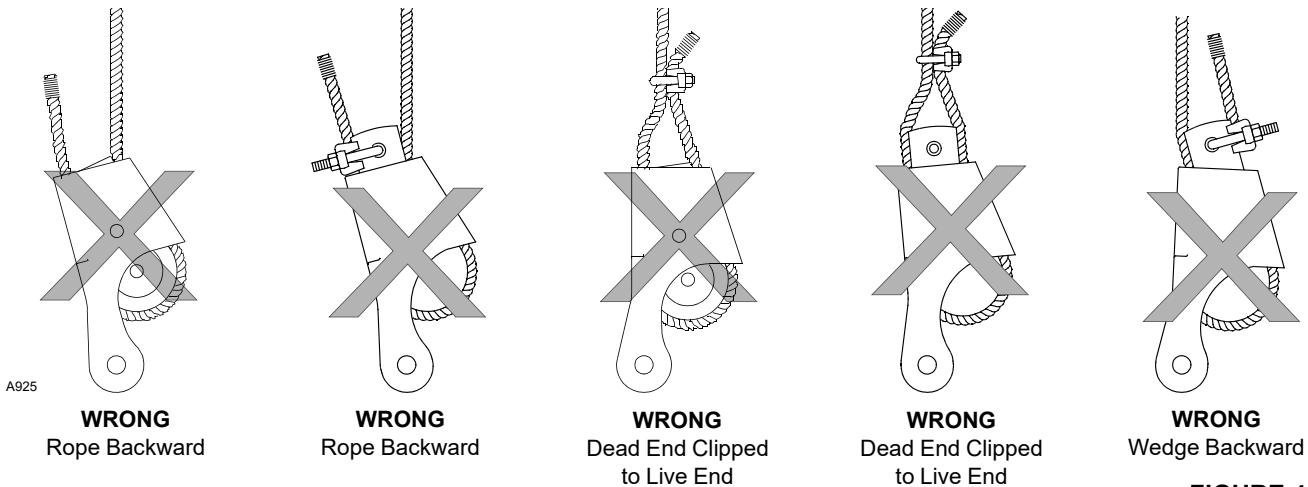

**FIGURE 4-66**

## Anchoring Wire Rope to Button Socket

See [Figure 4-67](#) for the following procedure.

1. Remove pin from socket.
2. Install button end of load line in socket.
3. Pin socket to anchor point.
4. Securely tighten locking screw.

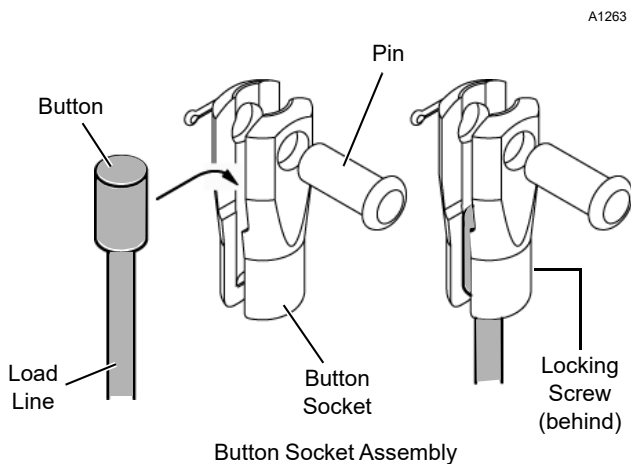

FIGURE 4-67

## Breaking in Wire Rope

After installing a new wire rope, break it in by operating it several times under light load and at reduced speed. This practice allows the wire rope to form its natural lay and the strands to seat properly.

**NOTE** Wire rope will stretch during the break-in period, reducing the wire rope's diameter as the strands compact around the core.

The dead wraps of wire rope on the drum can become slack during operation, even if the utmost care is used during installation of the wire rope. This slackening is caused by the normal stretch that occurs in a new wire rope under tension

and periodically throughout the wire rope's life from release of the load.

When slackness is noted, tightly wind the dead wraps of wire rope onto the drum. If left uncorrected, a wedging action with subsequent layers will occur, and the resultant abrasion may cause broken wires in the dead wraps.

## PAD EYE USAGE FOR WIRE ROPE REEVING

See [Figure 4-68](#) for the following procedure.

### General

Some rotation-resistant wire rope supplied by Manitowoc is equipped with a No. 1.5 pad eye welded to the leading end of the wire rope or to the button on the end of the wire rope.

A rigging line can be attached to the pad eye to make it easier to reeve the load block.

### Safety

1. For No. 1.5 pad eye, do not exceed 1,000 lb (4.45 kN) single line pull.
2. Make sure rigging line and attaching hardware (clips and rope connectors) are rated for at least 1,000 lb (4.45 kN) line pull.
3. Inspect pad eye prior to each use. **Replace it if:**
  - Any original dimensions have changed
  - Cracks or breaks exist in metal or weld



### WARNING

#### Flying Part Hazard!

Pad eye on end of wire rope has been provided **for reeving purposes only**. Any other use is neither intended nor approved.

Pad eye can break and fly apart with considerable force if it is overloaded, not used properly, or not maintained properly.

A1189  
A09310

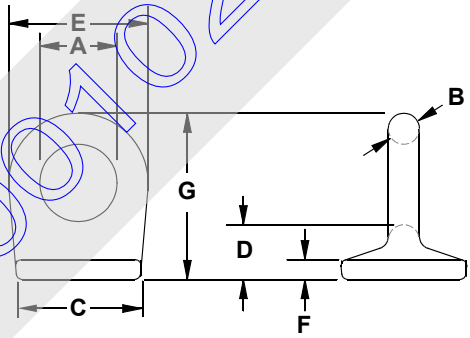
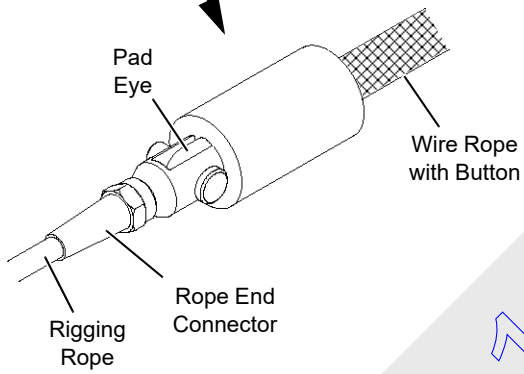
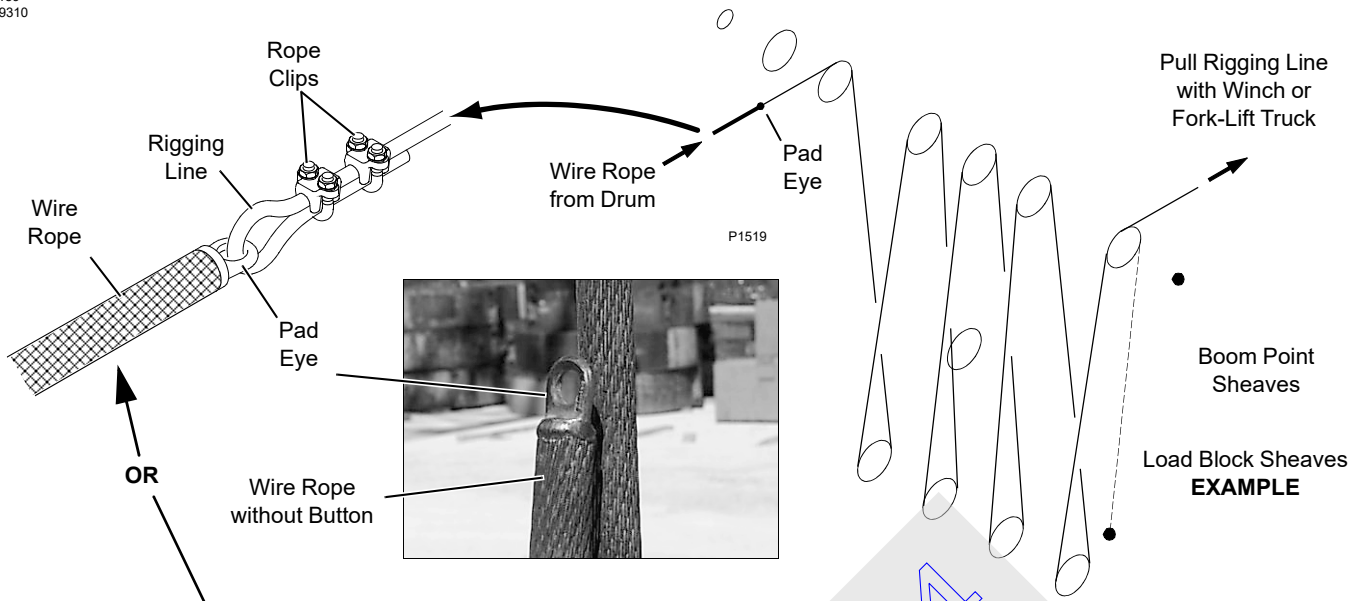

No. 1.0 Pad Eye		
Item	Inch	mm
A	3/8	9,65
B	1/4	6,35
C	7/8	22,40
D	13/32	10,40
E	7/8	22,40
F	1/8	3,30
G	1-1/32	26,20

No. 1.5 Pad Eye		
Item	Inch	mm
A	5/8	16,00
B	1/6	6,35
C	1	25,40
D	7/16	11,20
E	1-1/8	28,70
F	5/32	4,05
G	1-5/16	33,30

FIGURE 4-68

## RIGGING WINCH OPERATION

If your crane is equipped with the optional rigging winch (Drum 7), see the Rigging Winch Assembly drawing at the end of this section for wire rope routing.

### Selecting Rigging Winch Mode

**NOTE** See Section 3 in this manual for operation of the crane mode selector.

TO TURN RIGGING WINCH MODE ON —

1. Press bottom of confirm/select switch until **RIG WINCH** appears in display.
2. Press top of confirm/select switch to CONFIRM Rig WINCH mode.

**\*W** will appear next to main mode as shown in [Figure 4-69](#). The boom hoist handle on left console will now operate the rigging winch.

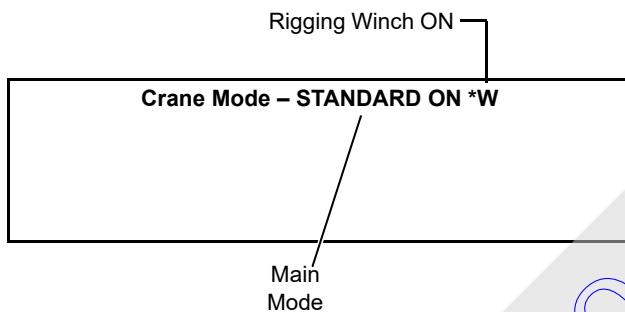

FIGURE 4-69

TO TURN RIGGING WINCH MODE OFF —

1. Turn confirm/select key switch to SELECT position until **RIG WINCH** appears in display.
2. Turn confirm/select key switch to CONFIRM position. **\*W** will disappear from display indicating rigging winch mode is OFF.

The rigging mode will automatically turn OFF when power to the control system is turned off.

### Operating Rigging Winch (Past Production)

1. Select and confirm rigging winch mode.
2. Pay out rigging rope either by pushing boom hoist handle forward or by turning on winch free-spool feature, as follows:
  - a. Pull locking pin (2, [Figure 4-70](#)) out and hold.
  - b. Pull knob (3) out.
  - c. Release locking pin (2).
  - d. Rope can now be pulled off winch drum manually.

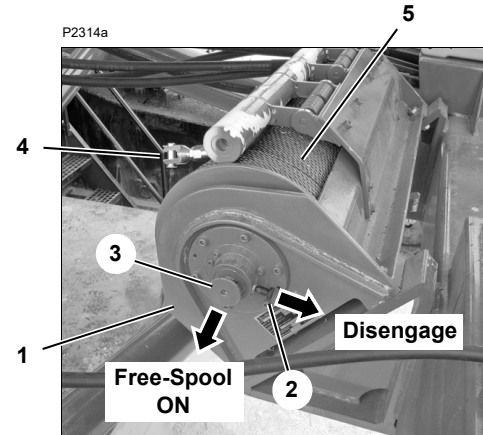

Item	Description
1	Rigging Winch (Drum 7)
2	Locking Pin
3	Knob
4	Rope End Connector (see NOTE)
5	Wire Rope: 5/16 in (8 mm) Diameter

**NOTE** Rope end connector can be connected to pad eye on end of rope from drum as shown in [Figure 4-68](#).

FIGURE 4-70

3. Route rigging rope through guide sheaves in boom butt. See Rigging Winch Assembly drawing at the end of this section.
4. Route rigging rope through load block and boom point sheaves, through guide sheaves on boom, and connect rigging rope to end of rope on desired drum (1, 2, 3, or 6). See Rigging Winch Assembly drawing at the end of this section.
5. If on, turn off winch free-spool feature:
  - a. Pull locking pin (2, [Figure 4-70](#)) out and hold.
  - b. Push knob (3) in.
  - c. Release locking pin (2).
6. Remove slack from rigging rope (pull boom hoist handle back) prior to paying out rope from drum.

**NOTE** The stall line pull of the rigging winch is regulated with a proportional relief valve controlled by the crane's programmable controller.

If engine speed is set too low when attempting to haul in rigging rope, the rope may go slack. If this happens, slowly increase engine speed until the rope tightens.



7. Move boom hoist control handle to off and push corresponding drum control handle forward to pay out rope from drum. Rigging winch will haul in rope automatically.

**NOTE** In rigging winch mode, the drum control handle farthest to the right controls Drums 3 and 6.

- To operate drum 3, drum 6 park switch must be on and drum 3 park switch must be off.
- To operate drum 6, drum 3 park switch must be on and drum 6 park switch must be off.

**CAUTION!**

**Avoid Rigging Winch or Wire Rope Damage!**

Rigging winch will not automatically pay out rope if selected drum control handle is pulled back to hoist position.

**Structural damage to winch or rigging line will occur!**

If it is necessary to haul in rope on drum when drum rope is connected to rigging rope, proceed as follows:

- Pay out rope with boom hoist control handle while hauling in rope with drum control handle.
- Keep rope from rigging winch slacker than rope from load drum.

**! WARNING**

**Flying Object Hazard!**

Do not attempt to disconnect rigging rope from drum rope until rope is slack.

**Rope could fly apart with explosive force and strike personnel.**

8. Once drum rope is reeved through load block and boom point:
  - a. Move drum control handle to off.
  - b. Push boom hoist handle forward to slacken rope.
  - c. Disconnect rigging rope from drum rope.
  - d. Pull boom hoist control handle back haul in rigging rope for storage on rigging winch.
  - e. Connect drum rope to dead-end socket. See instructions in this section.

**Operating Rigging Winch (Current Production)**

1. Select and confirm rigging winch mode.
2. Pay out rigging rope either by pushing boom hoist handle forward or by turning on winch free-spool feature, as follows:

**NOTE** Winch must be “at rest” and have no load on cable.

- a. Rotate gear shifting lever (1, [Figure 4-71](#)) 90° up.

Current Production Rigging Winch

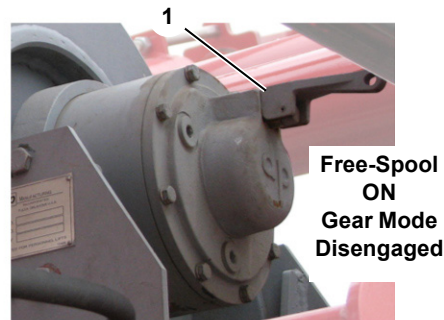
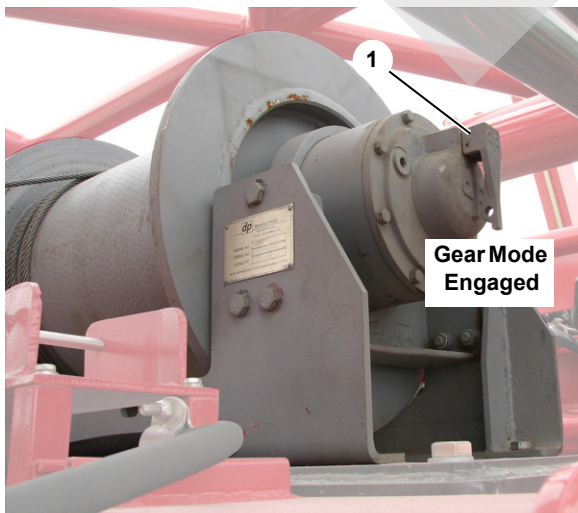

Item	Description
1	Gear Shifting Lever

M102484

FIGURE 4-71

3. Route rigging rope through guide sheaves in boom butt. See Rigging Winch Assembly drawing at the end of this section.
4. Route rigging rope through load block and boom point sheaves, through guide sheaves on boom, and connect rigging rope to end of rope on desired drum (1, 2, 3, or 6). See Rigging Winch Assembly drawing at end of this section.
5. If on, turn off winch free-spool feature:

**NOTE** Winch must be “at rest” and have no load on cable.

- a. Rotate gear shifting lever (1, [Figure 4-71](#)) 90° down.
- b. GEAR ENGAGEMENT — **slowly** rotate rigging winch 90° in pay out direction by moving boom hoist control handle forward and then **stop** rotation. **Slowly** rotate drum approximately 90° in the pay in direction by pulling back on boom hoist control handle to ensure gears are fully engaged.

6. Remove slack from rigging rope (pull boom hoist handle back) prior to paying out rope from drum.

**NOTE** The stall line pull of the rigging winch is regulated with a proportional relief valve controlled by the crane’s programmable controller.

If engine speed is set too low when attempting to haul in rigging rope, the rope may go slack. If this happens, slowly increase engine speed until the rope tightens.

7. Move boom hoist control handle to off and push corresponding drum control handle forward to pay out rope from drum. Rigging winch will haul in rope automatically.

**NOTE** In rigging winch mode, the drum control handle farthest to the right controls Drums 3 and 6.

- To operate drum 3, drum 6 park switch must be on and drum 3 park switch must be off.

- To operate drum 6, drum 3 park switch must be on and drum 6 park switch must be off.

## CAUTION!

### Avoid Rigging Winch or Wire Rope Damage!

Rigging winch will not automatically pay out rope if selected drum control handle is pulled back to hoist position.

#### **Structural damage to winch or rigging line will occur!**

If it is necessary to haul in rope on drum when drum rope is connected to rigging rope, proceed as follows:

- Pay out rope with boom hoist control handle while hauling in rope with drum control handle.
- Keep rope from rigging winch slacker than rope from load drum.

## WARNING

### Flying Object Hazard!

Do not attempt to disconnect rigging rope from drum rope until rope is slack.

**Rope could fly apart with explosive force and strike personnel.**

8. Once drum rope is reeved through load block and boom point:
  - a. Move drum control handle to off.
  - b. Push boom hoist handle forward to slacken rope.
  - c. Disconnect rigging rope from drum rope.
  - d. Pull boom hoist control handle back haul in rigging rope for storage on rigging winch.
9. Connect drum rope to dead-end socket. See instructions in this section.



## LOAD BLOCK REEVING

### Load Block Identification

See the Boom Assembly Drawings at the end of this section for a complete list of load blocks and weight balls available for this crane.

#### **WARNING** Falling Load Hazard!

Use only a load block with a capacity equal to or greater than load to be handled.

Avoid overloading load block sheave bearings. Attach load to duplex hook so load hangs straight.

Load block can fail if overloaded, allowing load to fall.

### Load Block Handling

Each load block as two lifting lugs as shown in [Figure 4-73](#), View A.

The load blocks can be stood up for reeving as shown in [Figure 4-73](#), View B.

### Wire Rope Specifications

See Wire Rope Specifications chart in Capacity Chart Manual for the following load block reeving information:

- Parts of line required to handle desired load
- Wire rope length required for various boom lengths and parts of line
- Maximum spooling capacity of load hoists

### Wire Rope Installation and Maintenance

See Wire Rope Installation in this section for instructions:

- Installing wire rope on drums
- Anchoring wire rope to drums

### Duplex Hook

Attach the load so it is balanced equally on the hook. Lifting slings must be within angles given in [Figure 4-72](#) to achieve maximum hook capacity. The duplex hook has a hole to which an optional shackle can be attached as shown in [Figure 4-72](#).

#### **WARNING** Falling Load Hazard!

Limit load to be handled with shackle to capacity of load block or shackle, whichever is less.

Load block or shackle can fail if overloaded, allowing load to fall.

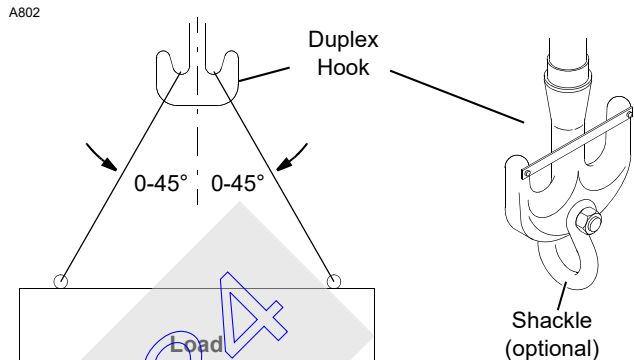

FIGURE 4-72

### Guide Sheaves and Drums

See [Figure 4-76](#) for identification of the load drums and guide sheaves.

Once wire rope is routed through the guide sheaves, be sure to install rope guard pins, bars, and rollers to retain the wire rope on the sheaves. **Wire rope and sheaves can be damaged if rope is not properly retained on sheaves.**

### Load Block Reeving

See [Figure 4-74](#) and [Figure 4-75](#) for dead-end locations and components in the lower and standard upper boom points.

See Extended Upper Boom Point Assembly Drawing at the end of this section for dead-end locations and components in the extended upper boom point.

See [Figure 4-77](#), [Figure 4-78](#), and [Figure 4-79](#) for load block reeving. Reeving the load block in any manner other than shown can result in excessive block twist.

#### **CAUTION**

##### Wire Rope Damage!

Do not hoist load block closer to boom point than shown on Range Diagram in Capacity Chart Manual. Improper fleet angle or contact with other parts can damage wire rope.

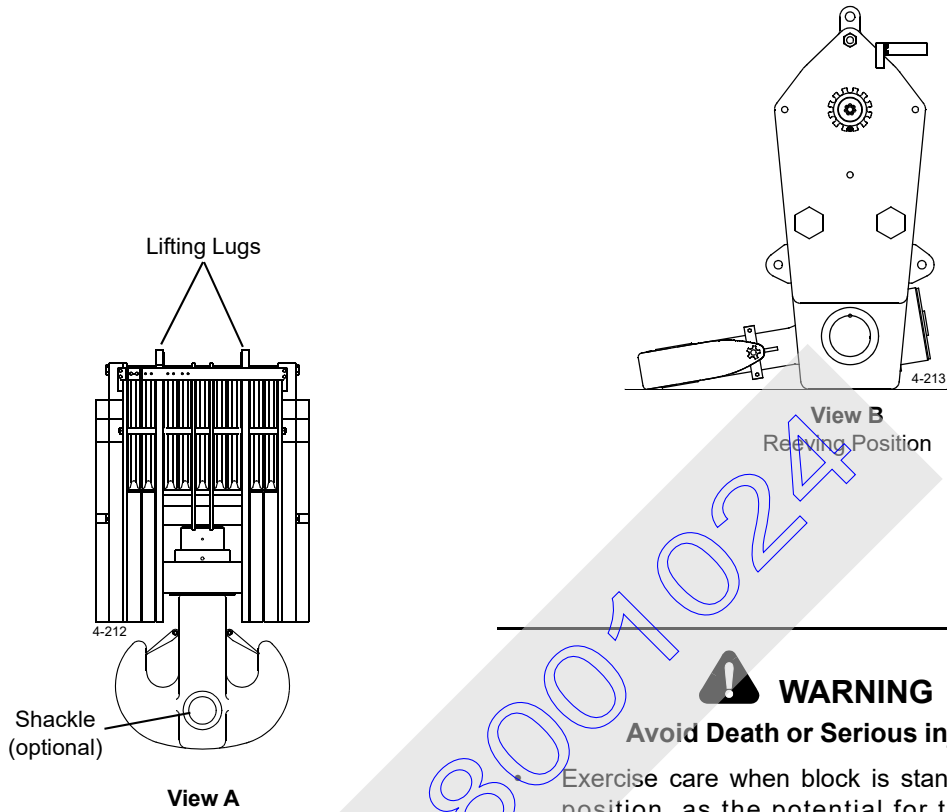

**WARNING**

**Avoid Death or Serious injury!**

- Exercise care when block is standing in vertical position, as the potential for tipping exists. Potential causes of tipping are unstable work area, boom movement and the reeving process.
- If work area is unstable, lay block flat on side plate.

FIGURE 4-73

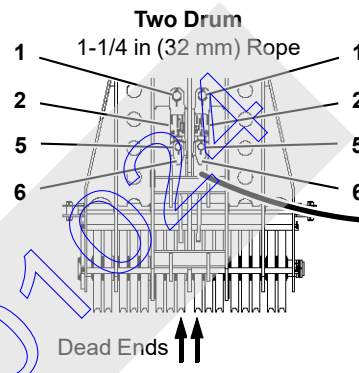
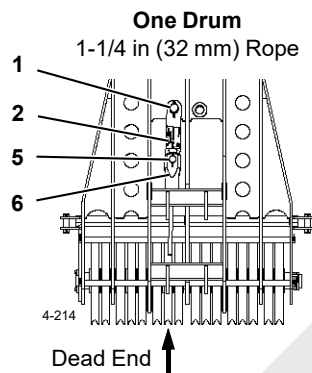
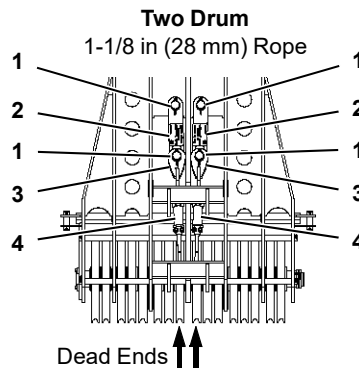
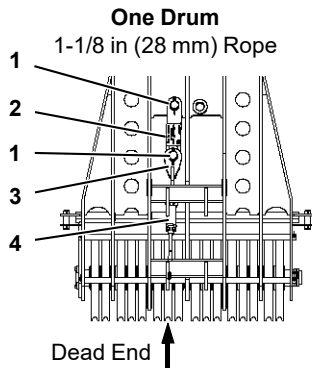

See [Figure 4-67](#)

**Two Drum – 55A Top**  
1-1/4 in (32 mm) Rope  
Capacities Greater Than 661 USt (600 t)

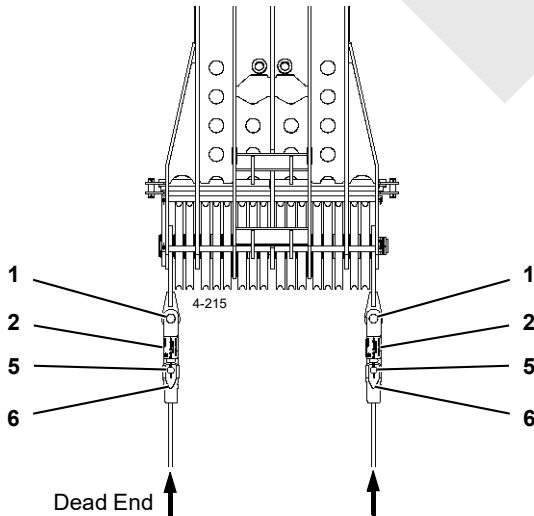

Item	Description
1	Pin with Cotter Pin
2	Load Cell - 70,000 lb (31 751 kg)
3	Link
4	Wedge Socket – 1-1/8 in (29 mm) with Pin and Cotter Pin
5	Bushing – 3 in OD x 2-9/32 in ID (76 mm OD x 56 mm ID)
6	Button Socket – 1-1/4 in (32 mm) with Pin and Cotter Pin

**FIGURE 4-74**  
**LOWER BOOM POINT**

STANDARD UPPER BOOM POINT A08516

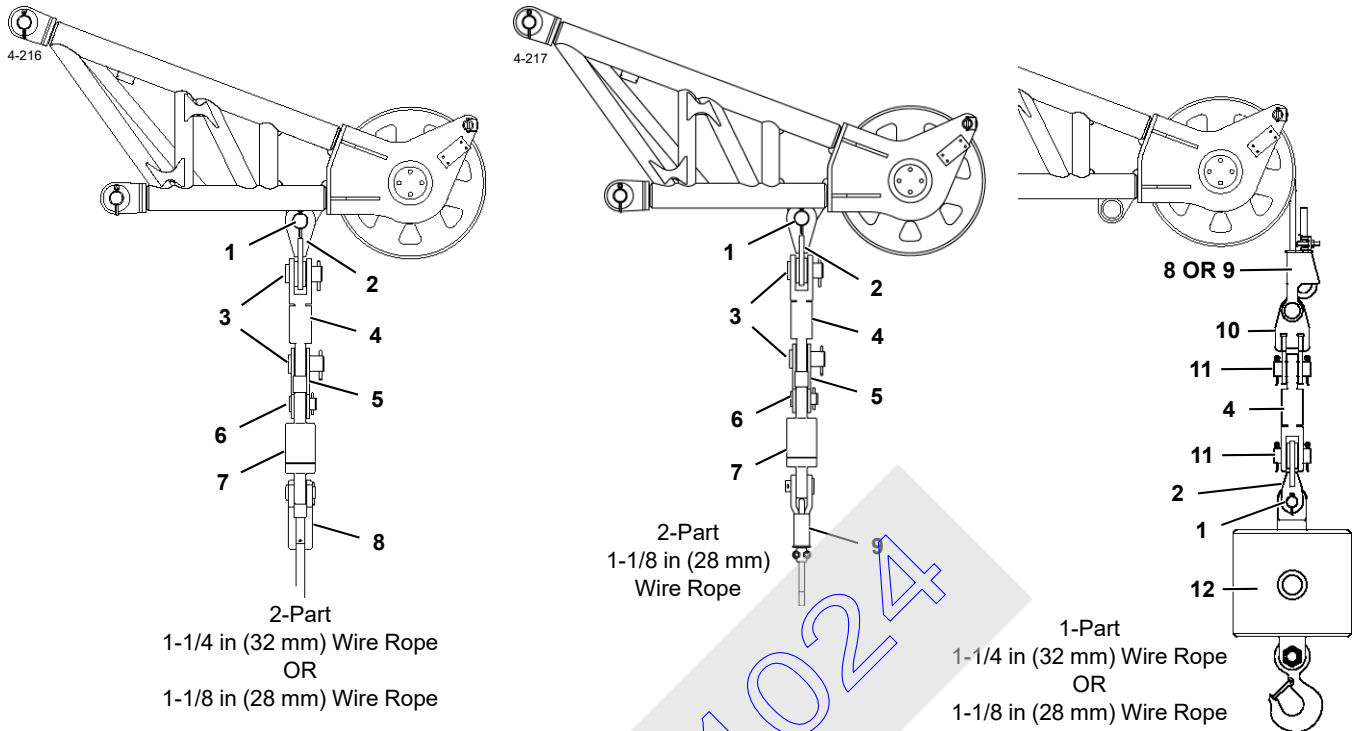

STANDARD UPPER BOOM (JIB) POINT 170419

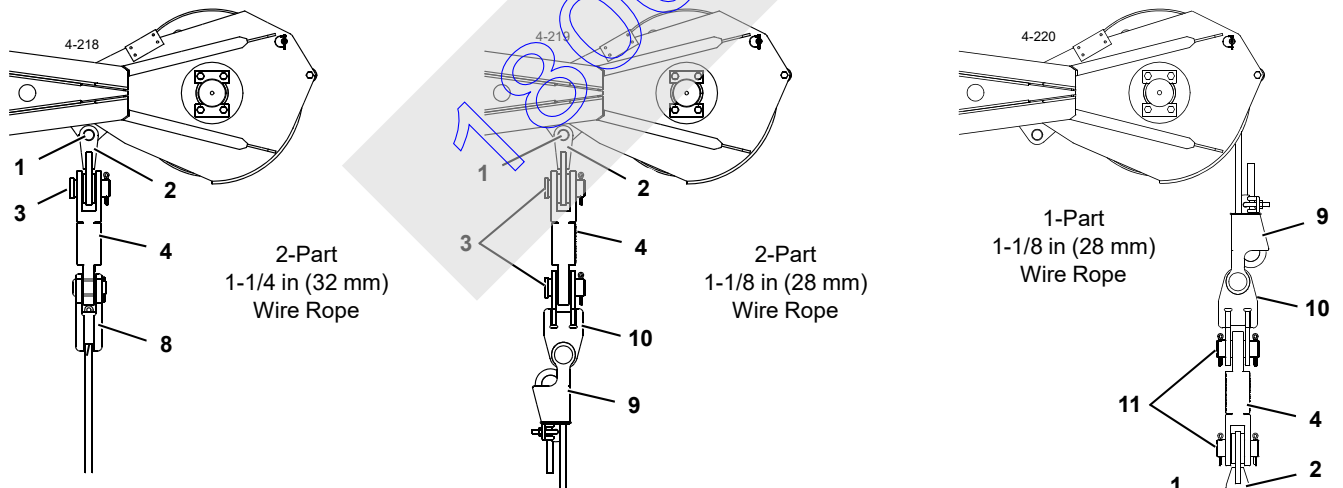

Item	Description	Item	Description
1	Pin with Cotter Pin	7	Swivel (25 USt)
2	Link	8	Button Socket – 1-1/8 in (28 mm) or 1-1/4 in (32 mm) Wire Rope with Pin
3	Pin with Cotter Pin	9	Wedge Socket – 1-1/8 in (28 mm)
4	Load Cell - 70,000 lb (31 751 kg)	10	Link
5	Link	11	Pin with Cotter Pin
6	Pin with Cotter Pin	12	Swivel Weight Ball

FIGURE 4-75

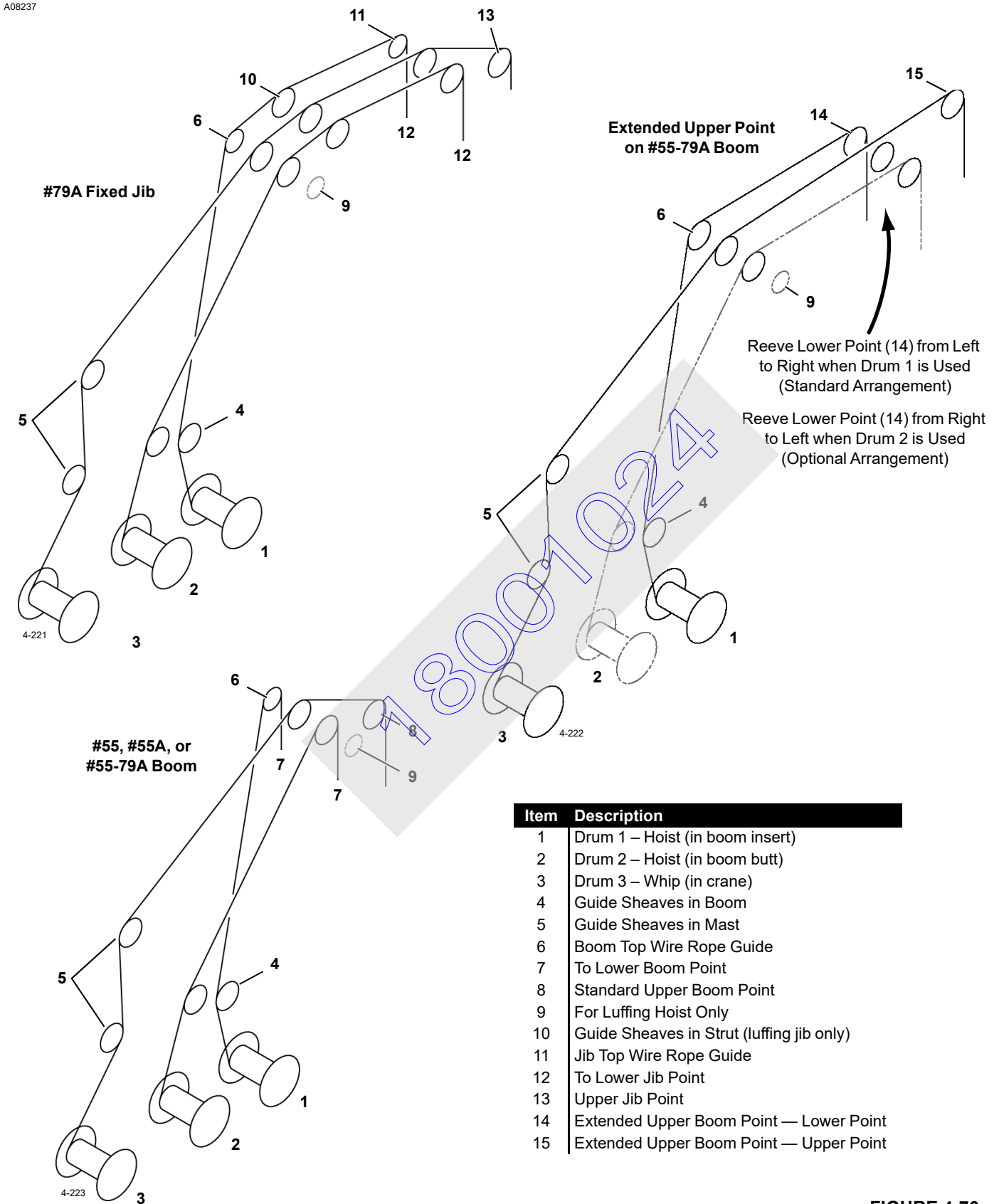

FIGURE 4-76

**SINGLE HOIST DRUM REEVING**  
**#55, #55A, and #79A Tops**

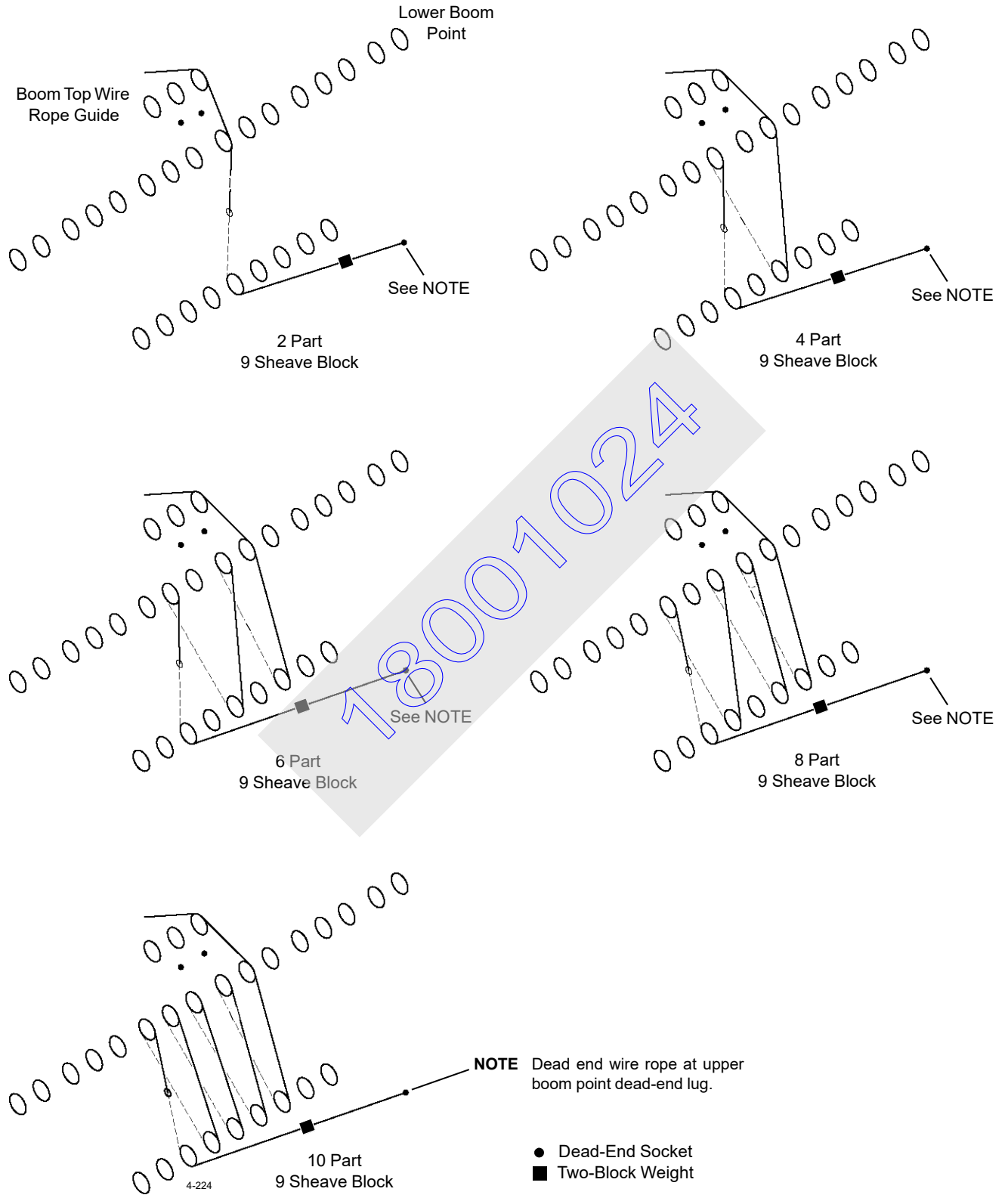

FIGURE 4-77



**SINGLE HOIST DRUM REEVING**  
**#55, #55A, and #79A Tops**

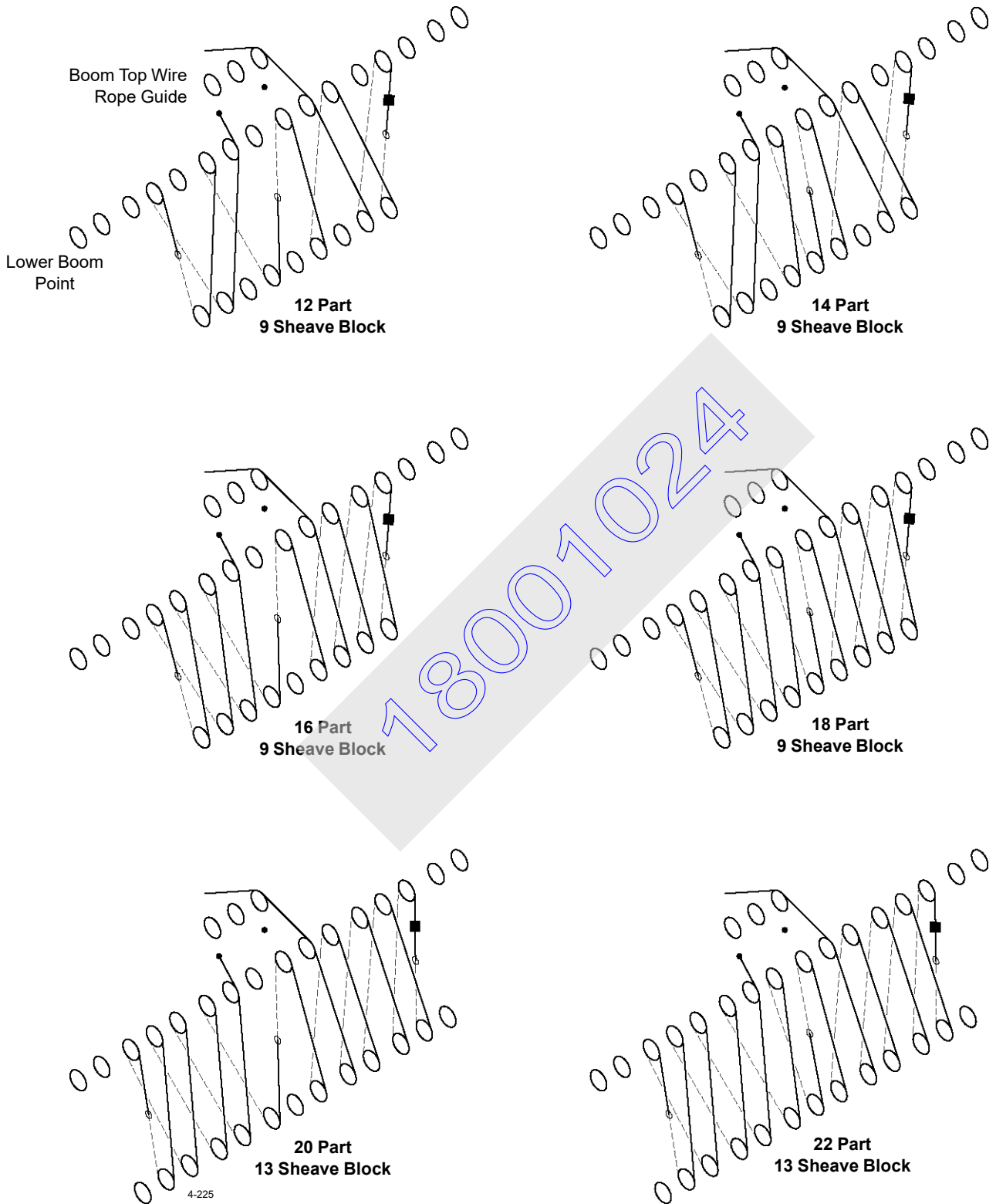

FIGURE 4-77 continued

**SINGLE HOIST DRUM REEVING**  
**#55, #55A, and #79A Tops**

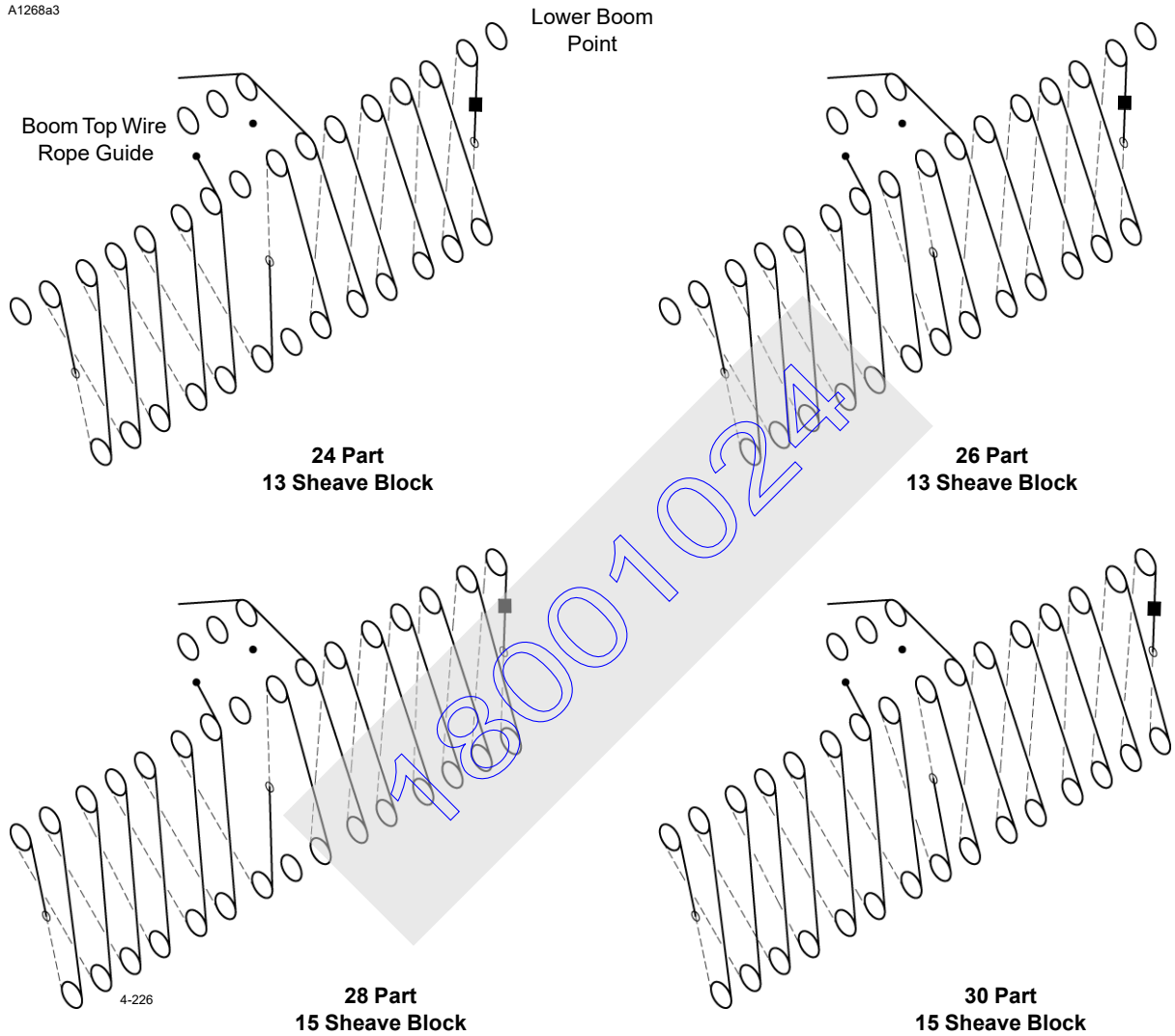

FIGURE 4-77 continued

A1268a4

**TANDEM HOIST DRUM REEVING**  
**#55, #55A, and #79A Tops**

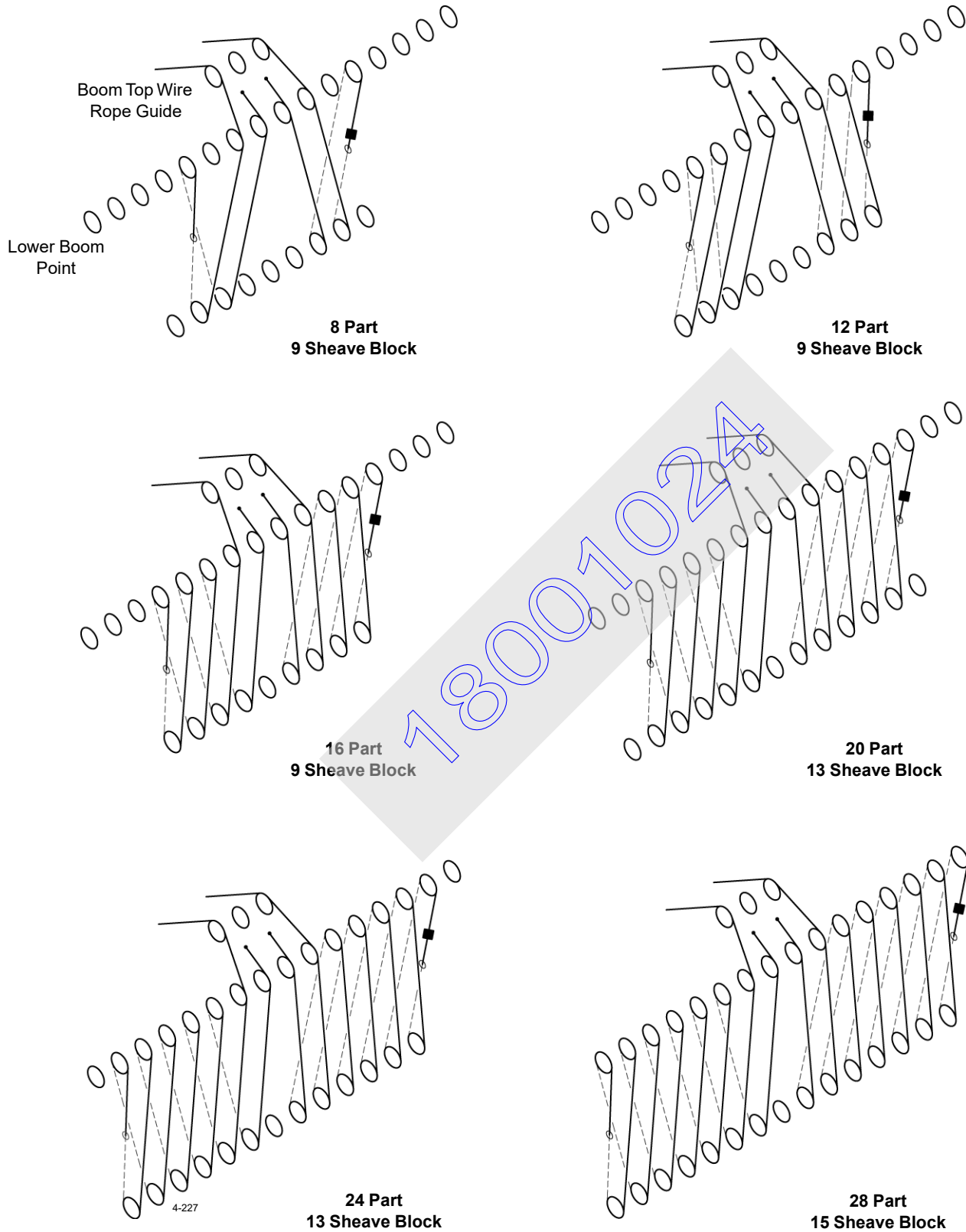
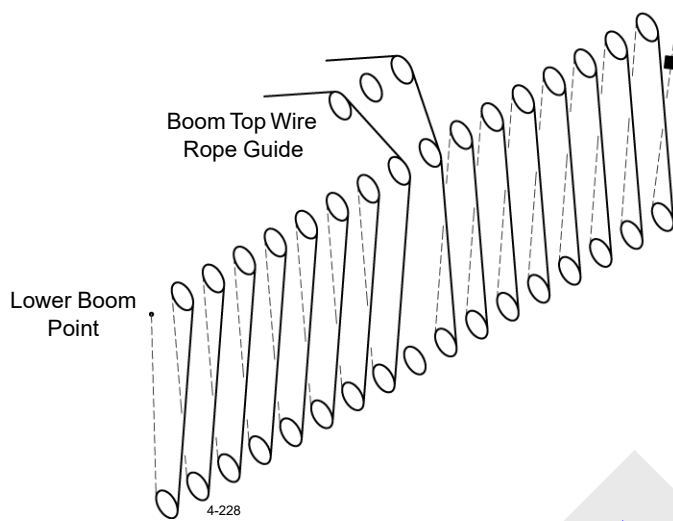

FIGURE 4-78

**TANDEM HOIST DRUM REEVING  
#55A Top**



**32 Part**  
**17 Sheave Block**  
 1-1/4 in (32 mm) Rope  
 Capacities Greater Than 661 US (600 t)

**FIGURE 4-78 continued**

**SINGLE HOIST DRUM REEVING  
Extended Upper Boom Point on #79A Top**

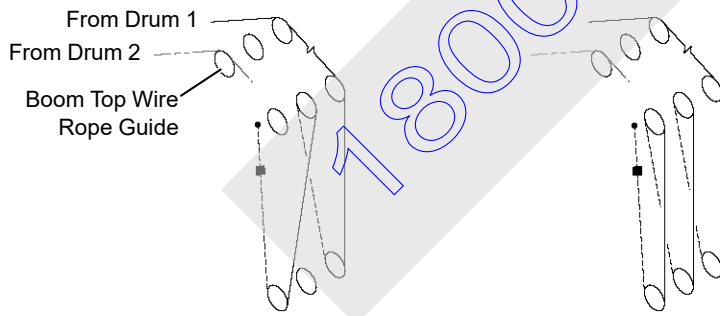

**4 Part**  
 3 Sheave Lower Point  
 1-1/4 in (32 mm) Wire Rope

**6 Part**  
 3 Sheave Lower Point  
 1-1/4 in (32 mm) Wire Rope

Standard Arrangement —  
 Reeve Lower Point from Left to  
 Right when Drum 1 is Used

Optional Arrangement —  
 Reeve Lower Point from Right to  
 Left when Drum 2 is Used

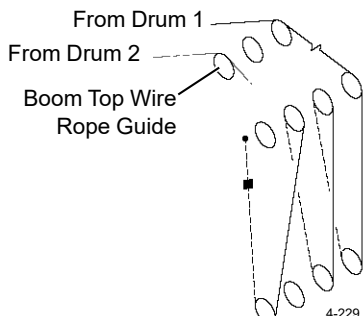

**6 Part**  
 4 Sheave Lower Point  
 1-1/8 in (28 mm) Wire Rope

**8 Part**  
 4 Sheave Lower Point  
 1-1/8 in (28 mm) Wire Rope

**FIGURE 4-79**

## BLOCK LEVEL SENSOR ADJUSTMENT

### General

The block level sensors (Figure 4-80) ensure that the load block remains level when two load lines — Drums 1 and 2 — are routed to the load block.

**NOTE** This block level is only on cranes without wireless communication. On cranes with wireless communication the controller adjusts the block level automatically (see Crane Diagnostics, Block Level Sensor topic in Section 3 of this manual).

The sensors monitor guide sheave rotation speed. The crane's programmable controller uses signals from the sensors to equalize the rotation speed of the drums so the load block remains level.

The sensors were adjusted at the factory and need to be readjusted only when a new sensor is installed or the position of a sensor is changed.

### Sensor Adjustment

1. If necessary, attach mounting bracket to guide sheave frame with cap screws.
2. Loosen jam nut securing sensor to bracket.
3. Turn sensor in or out to obtain specified dimension between end of sensor and wall of sheave.
4. Tighten jam nut.
5. Check for proper operation without load. Drums should operate at same speed and load block should remain level.

Readjust sensor if required.

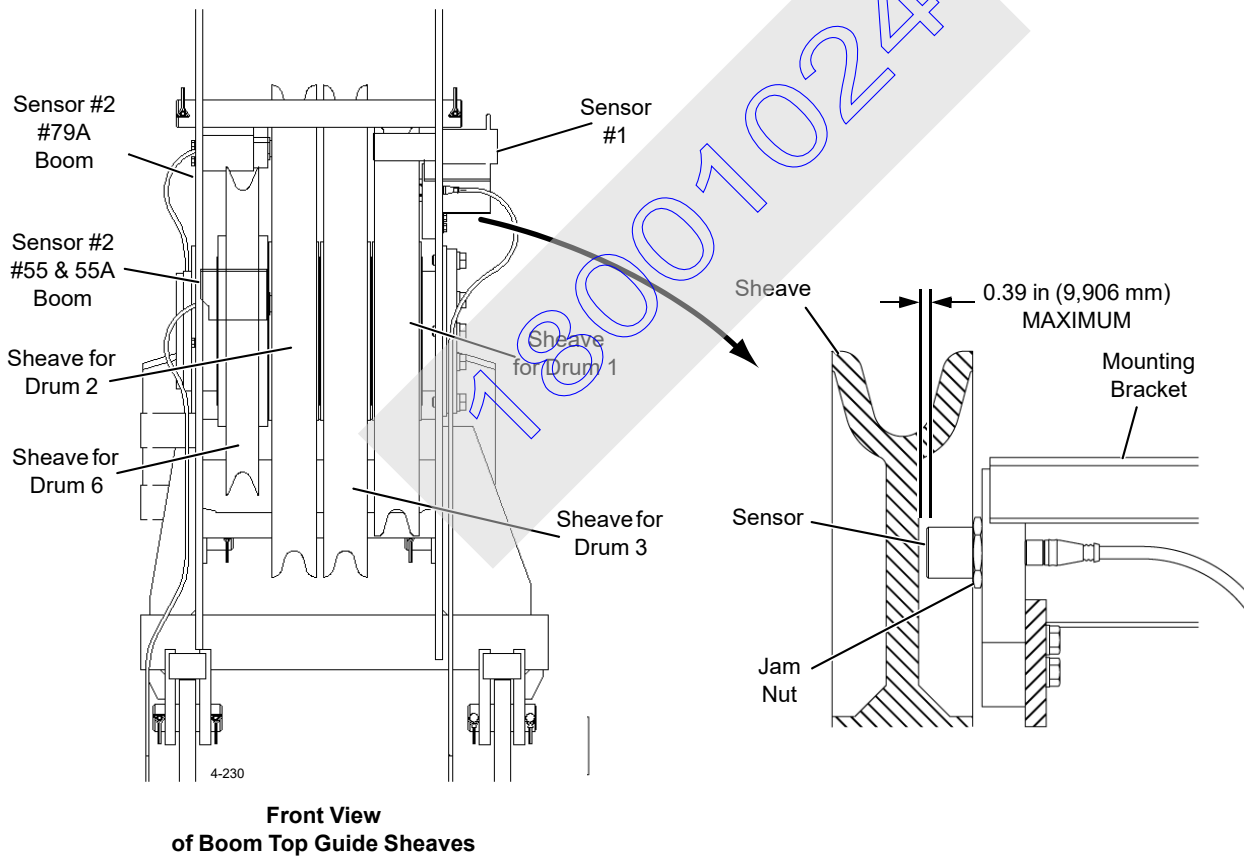

FIGURE 4-80

# LIVE MAST REEVING

## General

The live mast wire rope must be reeved between Drum 5 and the mast hoist sheaves as shown in [Figure 4-81](#).

Manitowoc provides a 7/8 in (22 mm) terminator socket and wedge for anchoring the wire rope to the mast hoist sheave cluster on the rotating bed.

## Wire Rope Specification

See Wire Rope Specifications chart in Capacity Chart Manual.

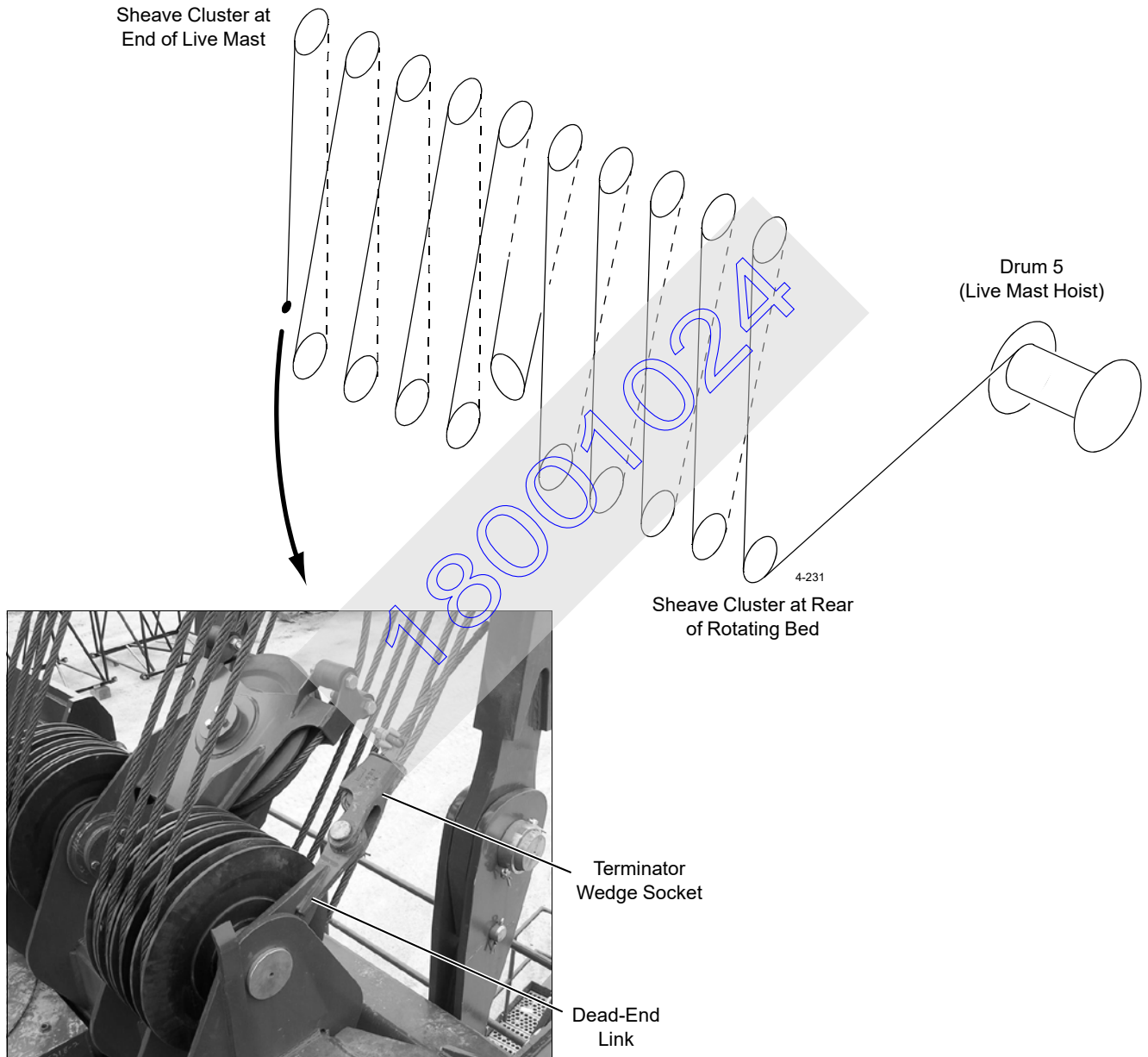

FIGURE 4-81

*THIS PAGE INTENTIONALLY LEFT BLANK*

18001024



**SECTION 5  
LUBRICATION**

**TABLE OF CONTENTS**

Lubrication .....5-1



**THIS PAGE INTENTIONALLY LEFT BLANK**

18001024

## SECTION 5 LUBRICATION

### LUBRICATION

See F2104 at the end of this section.



***THIS PAGE INTENTIONALLY LEFT BLANK***

18001024

# SECTION 6 MAINTENANCE CHECKLIST

## TABLE OF CONTENTS

Inspection and Maintenance Checklist .....	6-1
Fiberglass Maintenance .....	6-1

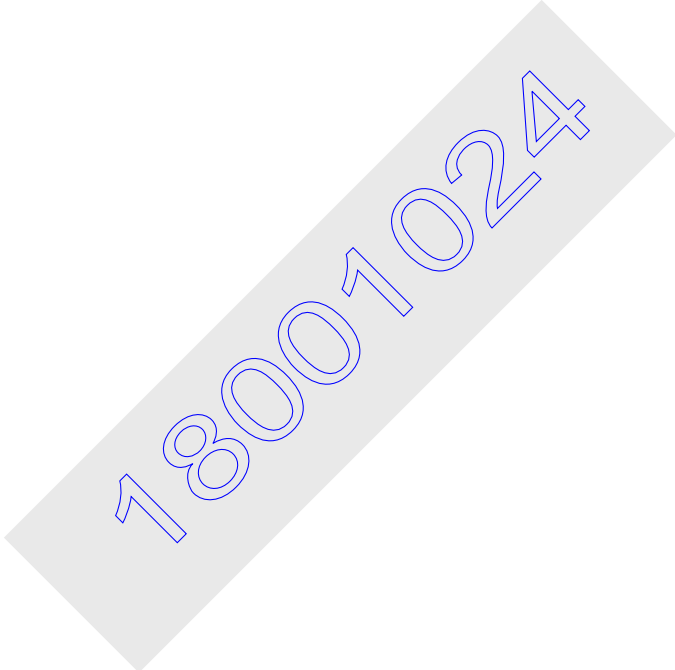

**THIS PAGE INTENTIONALLY LEFT BLANK**

18001024

## SECTION 6 MAINTENANCE CHECKLIST

### INSPECTION AND MAINTENANCE CHECKLIST

See F2097 at the end of this section.

### FIBERGLASS MAINTENANCE

See Bulletin W04-009 at the end of this section





**THIS PAGE INTENTIONALLY LEFT BLANK**

18001024

# ALPHABETICAL INDEX

Assembling, Disassembling, or Operating Crane Near Electric Power and Transmission Lines . . . .	2-15
Accessing Parts . . . . .	4-2
Accidents . . . . .	2-16
Assembly And Disassembly Area . . . . .	4-2
Assembly and Disassembly Notes . . . . .	4-2
Assist Crane Requirements . . . . .	4-2
Block Level Sensor Adjustment . . . . .	4-136
Boom and Jib Rigging . . . . .	4-80
Boom Disassembly Safety . . . . .	2-20
Boom Ladder Assembly . . . . .	4-76
Cab Door Adjustment . . . . .	3-11
Calibration Procedures . . . . .	3-35
Change of Ownership Registration . . . . .	1-1
Circuit Breakers . . . . .	3-87
Cold Weather Heater Package . . . . .	3-85
Cold Weather Mast Operation . . . . .	4-5
Continuous Innovation . . . . .	2-1
Controls Identification And Function . . . . .	3-14
Crane Access Points . . . . .	2-4
Crane Assembly . . . . .	4-9
Crane Data . . . . .	1-1
Crane Diagnostics . . . . .	3-57
Crane Disassembly . . . . .	4-59
Crane Orientation . . . . .	1-1
Crane Orientation . . . . .	3-12
Crane Orientation . . . . .	4-1
Crane Weights . . . . .	1-6
Crane Weights . . . . .	4-2
Crane/Attachment Identification . . . . .	1-1
Digital Display Screens . . . . .	3-48
Digital Input and Output Item Tables . . . . .	3-67
Display Language . . . . .	3-12
Electrocution Hazard Devices . . . . .	2-27
Engine Diagnostics . . . . .	3-55
English And Metric Conversions . . . . .	1-11
Environmental Protection . . . . .	2-18
Fiberglass Maintenance . . . . .	6-1
Fire Extinguishers . . . . .	2-16
Front Window Operation . . . . .	3-12
Function Speed/Torque Adjustment . . . . .	3-55
General Safety . . . . .	4-1
Getting On or Off Crane . . . . .	2-4
Handling Components . . . . .	4-2
Hydraulic System Calibration Procedures . . . . .	3-71
Identification And Location Of Components . . . . .	1-2
Inspection and Maintenance Checklist . . . . .	6-1
Introduction . . . . .	1-1
Live Mast Reeving . . . . .	4-137
Load Block Reeving . . . . .	4-126
Lubrication . . . . .	5-1
Lubrication . . . . .	5-1
Maintenance Checklist . . . . .	6-1
Manitowoc Dealer . . . . .	1-1

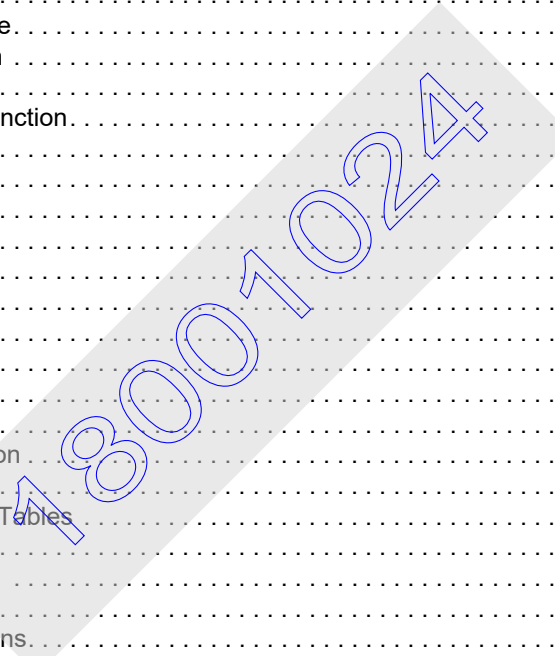

Multiple Crane Lifts . . . . .	2-28
Multiple Load Line Operation . . . . .	2-27
Nameplates and Decals . . . . .	2-1
Operating Controls And Procedures . . . . .	3-1
Operating Controls . . . . .	3-12
Operating Controls . . . . .	4-8
Operation. . . . .	3-36
Operational Aids . . . . .	2-13
Operator Manual/Capacity Chart Storage . . . . .	2-7
Optional Attachments . . . . .	4-1
Outline Dimensions . . . . .	1-4
Pad Eye Usage for Wire Rope Reeving . . . . .	4-121
Pedestal/Barge Mounted Cranes . . . . .	2-22
Personal Fall-Protection . . . . .	2-7
Personnel Handling Policy . . . . .	2-21
Pile Driving and Extracting . . . . .	2-26
Preparation for Cold Weather . . . . .	3-86
Preparing Crane for Operation . . . . .	3-35
Pre-Raising Checks. . . . .	4-56
Pre-Start Checks . . . . .	4-9
Raising Boom and Jib . . . . .	4-57
Refueling . . . . .	2-16
Remote Controls . . . . .	3-45
Retaining Connecting Pins . . . . .	4-5
Rigging Drawings . . . . .	4-1
Rigging Winch Operation . . . . .	4-123
Safe Maintenance . . . . .	2-17
Safe Operating Practices . . . . .	2-8
Safety and Information Signs . . . . .	2-3
Safety Devices . . . . .	2-13
Safety Information . . . . .	2-1
Safety Messages. . . . .	2-1
Seat Controls. . . . .	3-34
Self-Erecting Equipment . . . . .	4-1
Set-Up and Installation . . . . .	4-1
Shipping Crane Components . . . . .	4-8
Signals. . . . .	2-12
Special Application/Service . . . . .	2-21
Standard Hand Signals for Controlling Crane Operations. . . . .	3-2
Stopping Engine/ Leaving Crane Unattended . . . . .	3-44
Symbol Identification . . . . .	3-4
Wind Conditions . . . . .	3-82
Wire Rope Installation . . . . .	4-117

18001024

18001024