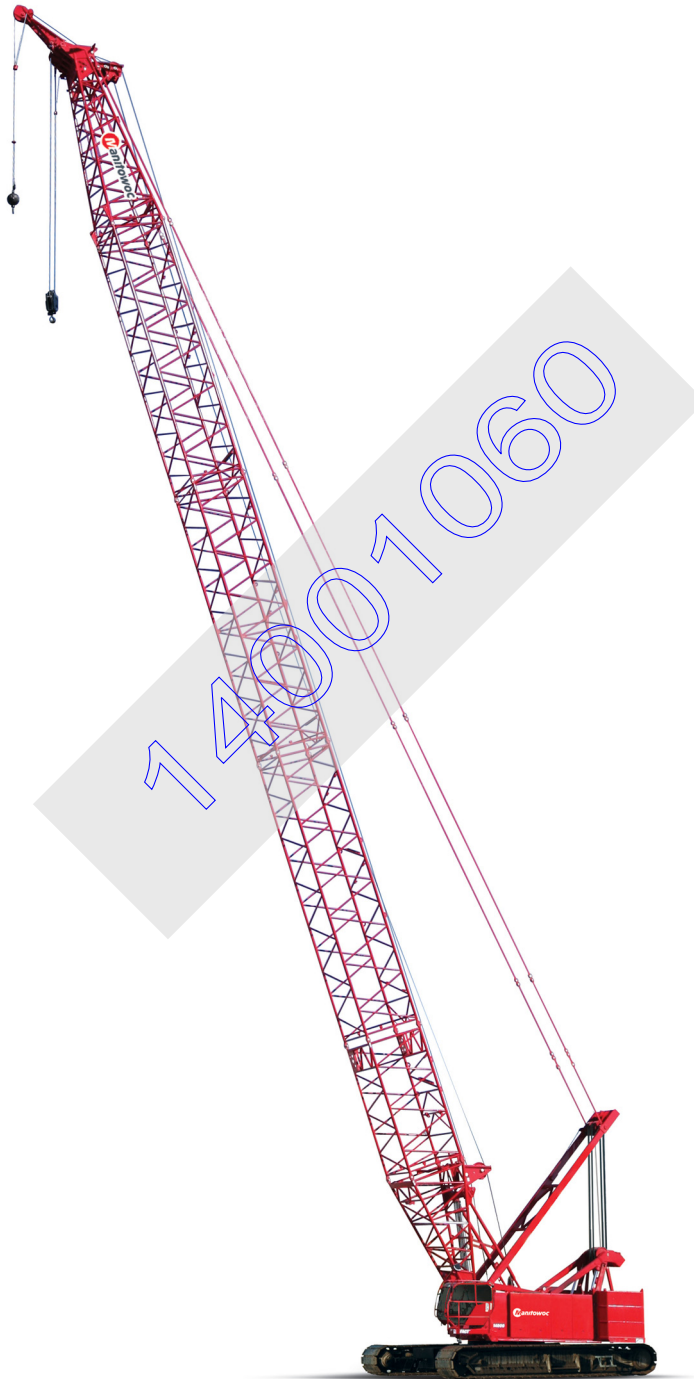


# Manitowoc 14000

## Operator Manual



Grove

Manitowoc

National Crane

Potain





# WARNING



## California Proposition 65

Breathing diesel engine exhaust exposes you to chemicals known to the State of California to cause cancer and birth defects or other reproductive harm.

Always start and operate the engine in a well-ventilated area.

If in an enclosed area, vent the exhaust to the outside.

Do not modify or tamper with the exhaust system.

Do not idle the engine except as necessary.

For more information, go to [www.P65warnings.ca.gov/diesel](http://www.P65warnings.ca.gov/diesel)

Batteries, battery posts, terminals, and related accessories can expose you to chemicals, including lead and lead compounds, which are known to the State of California to cause cancer and birth defects or other reproductive harm. Wash hands after handling. For more information, go to [www.P65warnings.ca.gov](http://www.P65warnings.ca.gov)



## California Spark Arrestor

Operation of this equipment may create sparks that can start fires around dry vegetation. A spark arrestor may be required. The owner/ operator should contact local fire agencies for laws or regulations relating to fire prevention requirements.



# OPERATOR MANUAL

This manual has been prepared for and is considered part of -

**14000**

Crane Model Number

**XXXXXRef**

Crane Serial Number

This Manual is divided into the following sections:


<b>SECTION 1</b>	<b>INTRODUCTION</b>
<b>SECTION 2</b>	<b>SAFETY INFORMATION</b>
<b>SECTION 3</b>	<b>OPERATING CONTROLS AND PROCEDURES</b>
<b>SECTION 4</b>	<b>SETUP AND INSTALLATION</b>
<b>SECTION 5</b>	<b>LUBRICATION</b>
<b>SECTION 6</b>	<b>MAINTENANCE CHECKLIST</b>

## NOTICE

The serial number of the crane and applicable attachments (i.e. luffing jib, MAX-ER<sup>®</sup>) is the only method your Manitowoc dealer or Manitowoc Product Support has of providing you with correct parts and service information.

The serial number is located on a crane identification plate attached to the operator's cab and each attachment. Refer to the Nameplate and Decal Assembly Drawing in Section 2 of this manual for the exact location of the crane identification plate.

**Always furnish serial number of crane and its attachments** when ordering parts or discussing service problems with your Manitowoc dealer or Manitowoc Product Support.

	<b>! WARNING</b>
	<p><b>To prevent death or serious injury:</b></p> <ul style="list-style-type: none"><li>• Avoid unsafe operation and maintenance. Crane and attachments must be operated and maintained by trained and experienced personnel. Manitowoc is not responsible for qualifying these personnel.</li><li>• Do not operate or work on crane or attachments without first reading and understanding instructions contained in Operator Information Manual and Service Manual supplied with crane and applicable attachments.</li><li>• Store Operator Information Manual and Service Manual in operator's cab.</li></ul> <p>If Operator Information Manual or Service Manual is missing from cab, contact your Manitowoc dealer for a new one.</p>

1

2

3

4

5

6

**THE ORIGINAL LANGUAGE OF THIS PUBLICATION IS ENGLISH**

14001060



See end of this manual for Alphabetical Index

<b>SECTION 1</b> .....	<b>Introduction</b>
Crane Data .....	1-1
Crane Weights .....	1-1
Crane/Attachment Identification .....	1-1
Reference to Past and Current Production in this manual .....	1-1
Change of Ownership Registration .....	1-1
Manitowoc Dealer .....	1-1
Crane Orientation .....	1-1
Identification and Location of Components .....	1-2
Outline Dimensions .....	1-4
English and Metric Conversions .....	1-6
Direct Conversion .....	1-6
Inverse Conversion .....	1-6
 <b>SECTION 2</b> .....	 <b>Safety Information</b>
Continuous Innovation .....	2-1
Nameplates and Decals .....	2-1
Safety Messages .....	2-1
General .....	2-1
Safety Alert Symbol .....	2-1
Signal Words .....	2-1
Symbol Identification .....	2-1
Safety and Information Signs .....	2-3
Maintaining Signs .....	2-3
Ordering Signs .....	2-3
Crane Access Points .....	2-4
General .....	2-4
Getting On or Off Crane .....	2-4
Personal Fall-Protection .....	2-6
Operator Manual/Capacity Chart Storage .....	2-6
General .....	2-6
Storing Manuals .....	2-6
Swing Radius Barrier .....	2-7
Deploying Swing Radius Barrier .....	2-7
Storing Swing Radius Barrier .....	2-7
Safe Operating Practices .....	2-8
General .....	2-8
Work Area Control .....	2-8
Read Operator Manual .....	2-8
Operator Qualifications .....	2-8
Operator Conduct .....	2-9
Handling Load .....	2-10
Signals .....	2-12
Safety Devices .....	2-13
Operational Aids .....	2-13
Category 1 Operational Aids .....	2-13
Category 2 Operational Aids .....	2-14
Assembling, Disassembling, or Operating Crane Near Electric Power and Transmission Lines .....	2-15
Electrocution Hazard .....	2-15
Set-Up and Operation .....	2-15
Electrical Contact .....	2-16
Refueling .....	2-16
Fire Extinguishers .....	2-16
Accidents .....	2-16
Safe Maintenance .....	2-17

Maintenance Instructions . . . . . 2-17

Safe Maintenance Practices . . . . . 2-17

Environmental Protection . . . . . 2-18

Boom Disassembly Safety . . . . . 2-20

    General . . . . . 2-20

    Location . . . . . 2-20

    Pin Removal . . . . . 2-20

    Disassembly Precaution . . . . . 2-20

Special Application/Service . . . . . 2-21

Personnel Handling Policy . . . . . 2-21

Pedestal/Barge Mounted Cranes . . . . . 2-22

    Pedestal Mounted Crane . . . . . 2-23

    Barge Mounted Crane . . . . . 2-23

    Capacity Charts for Barge Mounted Crane . . . . . 2-24

    Shock Loading Caused by Barge Dynamics . . . . . 2-25

    Operation on Barge . . . . . 2-25

    Barge Mount Definitions . . . . . 2-25

    Inspection of Barge-Mounted Crane . . . . . 2-25

    Transporting Crane on Barge . . . . . 2-26

Pile Driving and Extracting . . . . . 2-26

    Introduction . . . . . 2-26

    Operation of Pile Driving and Extracting Equipment . . . . . 2-26

    Crane Equipment . . . . . 2-26

    Crane Inspection . . . . . 2-26

Electrocution Hazard Devices . . . . . 2-27

Multiple Load Line Operation . . . . . 2-27

Multiple Crane Lifts . . . . . 2-28

**SECTION 3 . . . . . Operating Controls And Procedures**

Standard Hand Signals for Controlling Crane Operations . . . . . 3-2

Symbol Identification . . . . . 3-4

Cab Window Operation . . . . . 3-10

    Opening Windows for Ventilation . . . . . 3-10

    Exiting Cab in Emergency . . . . . 3-10

Operating Controls . . . . . 3-10

    General . . . . . 3-10

Controls Identification and Function . . . . . 3-14

    A – Engine Controls . . . . . 3-14

    B – Accessory Controls . . . . . 3-18

    C – Indicators . . . . . 3-21

    D – Special Controls . . . . . 3-22

    E – Boom Hoist Controls . . . . . 3-26

    F – Load Drum Controls . . . . . 3-27

    G – Swing Controls . . . . . 3-28

    H – Travel Controls . . . . . 3-29

Limit Devices . . . . . 3-30

    1. Boom Maximum Up Limit . . . . . 3-30

    2. Boom Down Limit . . . . . 3-30

    3. Block-Up Limit . . . . . 3-30

    4. Luffing Jib Up Limit . . . . . 3-31

    5. Luffing Jib Down Limit . . . . . 3-31

    6. Maximum Bail Limit . . . . . 3-32

    7. Minimum Bail Limit . . . . . 3-32

Seat Controls . . . . . 3-32

Preparing Crane for Operation . . . . . 3-33

Operation . . . . . 3-33

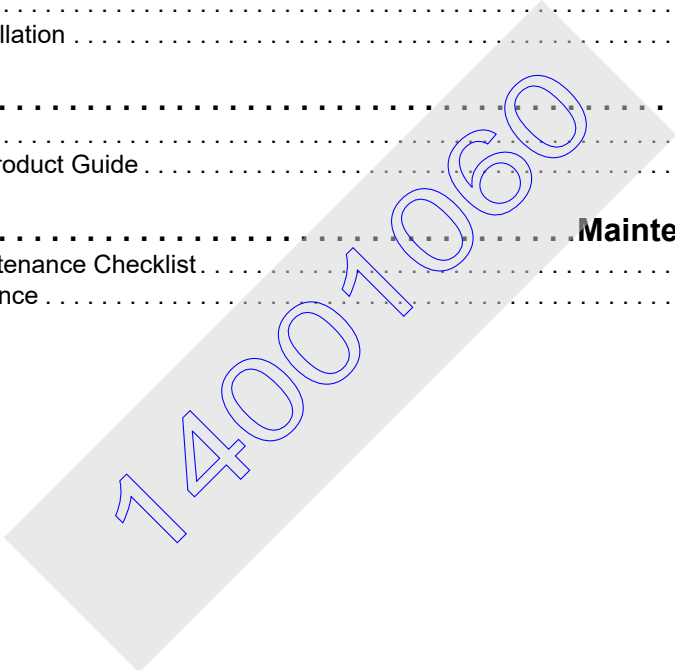
Engine Startup . . . . .	3-33
Boom Hoist Operation . . . . .	3-36
Luffing Hoist Operation . . . . .	3-37
Swing Operation . . . . .	3-38
Load Drum Operation . . . . .	3-39
Travel Operation . . . . .	3-42
Luffing Jib Setup Mode . . . . .	3-44
Stopping Engine/ Leaving Crane Unattended . . . . .	3-45
Remote Controls . . . . .	3-45
General . . . . .	3-45
Set-Up Remote Control . . . . .	3-45
Manual Controlled Handles . . . . .	3-47
Displays . . . . .	3-48
Display Controls . . . . .	3-48
Display Brightness and Color Contrast . . . . .	3-48
Factory Default Display Settings . . . . .	3-48
Blank Display . . . . .	3-48
Main GUI Display Format . . . . .	3-49
Screen Prompts . . . . .	3-49
Menu Screen . . . . .	3-50
Information Screen . . . . .	3-50
Diagnostic Screens . . . . .	3-54
Function Mode Screens . . . . .	3-57
CAN Bus Diagnostic Screen . . . . .	3-62
Camera Screen (Optional) . . . . .	3-68
Pressure Test and Calibration Screen . . . . .	3-68
Wind Conditions . . . . .	3-71
Preparation for Cold Weather . . . . .	3-73
Crane Limitations . . . . .	3-73
Wire Rope . . . . .	3-73
Cold Weather Starting Aid . . . . .	3-73
Cooling System . . . . .	3-73
Batteries . . . . .	3-73
Engine Oil . . . . .	3-73
Fuel Oil . . . . .	3-73
Gear Oil . . . . .	3-73
Hydraulic Oil . . . . .	3-74
Cold Weather Heater Package . . . . .	3-75
General . . . . .	3-75
Heaters . . . . .	3-75
Turning Heaters On . . . . .	3-75
Turning Heaters Off . . . . .	3-75
Circuit Breakers . . . . .	3-75
Cold Weather Package — Past . . . . .	3-76
Cold Weather Package — Current . . . . .	3-77

**SECTION 4. . . . . Setup And Installation**

Boom and Jib Assembly Drawings . . . . .	4-1
Liftcrane Mast Capacities . . . . .	4-1
Optional Attachments . . . . .	4-1
General Safety . . . . .	4-1
Crane Orientation . . . . .	4-1
Self-Erecting Equipment . . . . .	4-3
Assembly and Disassembly Notes . . . . .	4-3
Assembly and Disassembly Area . . . . .	4-3
Accessing Parts . . . . .	4-3

Crane Weights . . . . .	4-4
Handling Components . . . . .	4-4
Retaining Connecting Pins . . . . .	4-4
Cold Weather Mast Operation . . . . .	4-5
Shipping Crane Components . . . . .	4-5
Operating Controls . . . . .	4-6
Pre-Start Checks . . . . .	4-6
Engine . . . . .	4-6
Gear Boxes . . . . .	4-6
Hydraulic System . . . . .	4-6
Electric System . . . . .	4-6
Shipping Data . . . . .	4-7
Crane Assembly . . . . .	4-13
Remove Protective Covers from Cab Windows . . . . .	4-13
Remove Crane from Trailer . . . . .	4-15
Deploy Operator's Cab . . . . .	4-17
Raise Mast to Operating Position . . . . .	4-17
Install Assembly Block . . . . .	4-23
Install Crawlers . . . . .	4-25
Deploy Crawler Steps . . . . .	4-29
Install Platforms . . . . .	4-29
Assemble Boom and Jib . . . . .	4-29
Install Counterweight . . . . .	4-31
Install Boom Butt . . . . .	4-37
Remove Assembly Block . . . . .	4-41
Connect Boom Butt to Boom . . . . .	4-41
Pre-Raising Checks . . . . .	4-44
Crane Disassembly . . . . .	4-44
Lower Boom and Jib to Ground . . . . .	4-44
Disconnect Boom Butt from Boom . . . . .	4-47
Remove Boom Butt . . . . .	4-51
Remove Counterweight . . . . .	4-53
Disassemble Jib and Boom . . . . .	4-57
Remove Platforms . . . . .	4-57
Remove Crawlers . . . . .	4-59
Remove Assembly Block . . . . .	4-63
Lower Mast to Transport Position . . . . .	4-63
Install Protective Covers on Cab Windows . . . . .	4-65
Store Operator's Cab . . . . .	4-65
Install Crane on Trailer . . . . .	4-67
Boom Ladder . . . . .	4-68
General . . . . .	4-68
Removing Ladders from Storage . . . . .	4-68
Using Ladders . . . . .	4-69
Storing Ladders . . . . .	4-69
Boom and Jib Rigging . . . . .	4-69
Assist Crane Requirements . . . . .	4-69
Blocked Crawlers . . . . .	4-69
Handling Components . . . . .	4-70
Assembly Drawings . . . . .	4-70
Identifying Boom and Jib Components . . . . .	4-71
Boom Installation – #76 . . . . .	4-75
Boom Removal . . . . .	4-85
Lower Boom Point Assembly . . . . .	4-89
Jib Installation – #134 . . . . .	4-91
Jib Removal – #134 . . . . .	4-96
Pile Driver Adapter Installation . . . . .	4-97

Wire Rope Installation .....	4-98
Wire Rope Storage .....	4-98
Removing Wire Rope from Shipping Reel .....	4-98
Seizing and Cutting Wire Rope .....	4-98
Anchoring Wire Rope to Drum .....	4-99
Winding Wire Rope onto Drum .....	4-101
Anchoring Wire Rope to Socket and Wedge .....	4-102
Anchoring Wire Rope to Button Socket .....	4-104
Breaking in Wire Rope .....	4-104
Pad Eye Usage for Wire Rope Reeving .....	4-104
Load Line Reeving .....	4-107
Wire Rope Specifications .....	4-107
Wire Rope Installation .....	4-107
Liftcrane .....	4-107
Load Block Tieback .....	4-119
General .....	4-119
Specifications .....	4-119
Boom Hoist Reeving .....	4-119
Wire Rope Installation .....	4-119
<b>SECTION 5 .....</b>	<b>Lubrication</b>
Lubrication .....	5-1
Lube and Coolant Product Guide .....	5-1
<b>SECTION 6 .....</b>	<b>Maintenance Checklist</b>
Inspection and Maintenance Checklist .....	6-1
Fiberglass Maintenance .....	6-1



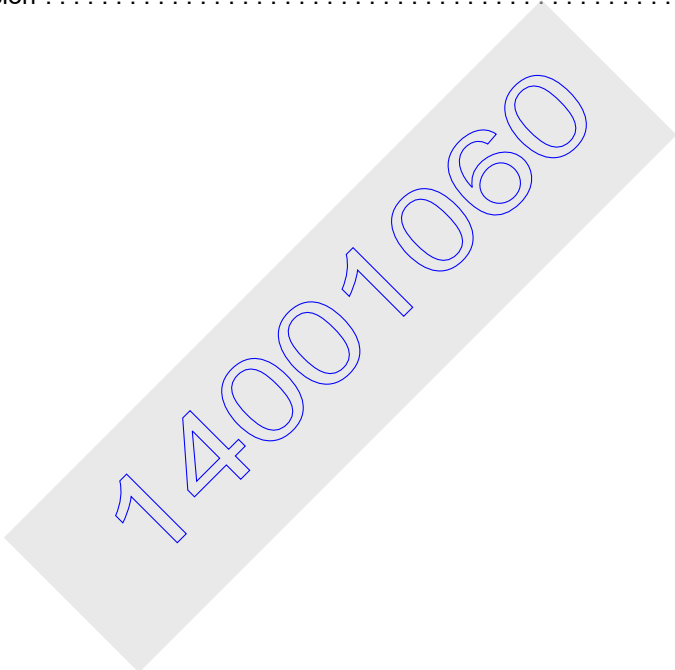
**THIS PAGE INTENTIONALLY LEFT BLANK**

14001060

# SECTION 1 INTRODUCTION

## TABLE OF CONTENTS

Crane Data .....	1-1
Crane Weights .....	1-1
Crane/Attachment Identification .....	1-1
Reference to Past and Current Production in this manual .....	1-1
Change of Ownership Registration .....	1-1
Manitowoc Dealer .....	1-1
Crane Orientation .....	1-1
Identification and Location of Components .....	1-2
Outline Dimensions .....	1-4
English and Metric Conversions .....	1-6
Direct Conversion .....	1-6
Inverse Conversion .....	1-6



**THIS PAGE INTENTIONALLY LEFT BLANK**

14001060



# SECTION 1 INTRODUCTION

## CRANE DATA

See the end of this section for crane data specific to your crane:

- Basic Specifications
- EC Declaration (if applicable)

## CRANE WEIGHTS

See the end of this section for crane weights.

## CRANE/ATTACHMENT IDENTIFICATION

An identification plate is attached to the outside of the operator’s cab (see [Figure 1-1](#)) and to the attachments (i.e. luffing jibs) available for this crane.

The crane or attachment model and serial number are etched into the plate.

For the exact location of the identification plates on your crane and attachments, refer to the Nameplates and Decals Drawing in Section 2 of this manual.

## REFERENCE TO PAST AND CURRENT PRODUCTION IN THIS MANUAL

Reference is made throughout this manual to “Past Production” and “Current Production” cranes and components. Refer to the serial number of your crane and [Table 1-1](#) to properly identify in which category your crane and its components falls.

**Table 1-1**

Serial Number Range	Type of Production
14001001 - 14001136	Tier 3 Past Production
14001137 and up	Tier 3 Current Production
14001137 and up	Tier 4 Production

## CHANGE OF OWNERSHIP REGISTRATION

If you are the new owner of a Manitowoc crane, please register it with Manitowoc Product Support so we can contact you if the need arises.

1. Go to [www.manitowoc.com](http://www.manitowoc.com)
2. Go to SUPPORT>SERVICES>CHANGE OF OWNERSHIP.
3. Complete the form.

## MANITOWOC DEALER

For questions about this manual or the 14000 crane, contact your Manitowoc dealer. If you do not know the contact information for your dealer, locate the Manitowoc dealer nearest you, as follows:

1. Go to [www.manitowoc.com](http://www.manitowoc.com)
2. Click on the red FIND A DEALER button.
3. Follow the on-screen prompts to locate your Manitowoc dealer.

## CRANE ORIENTATION

The terms RIGHT, LEFT, FRONT, REAR used in this manual refer to operator’s right, left, front, and rear sides when seated in the operator’s cab looking forward.

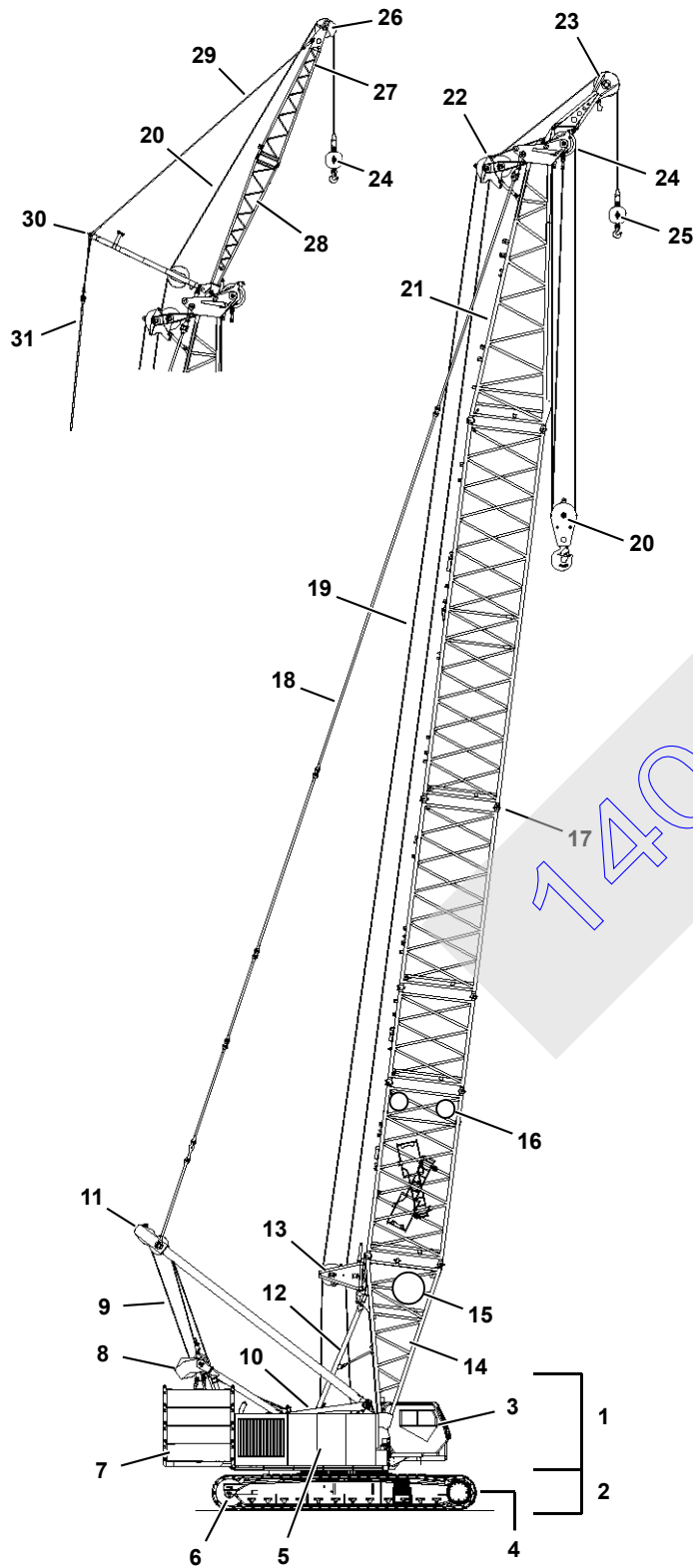
- The boom is on the front of the rotating bed
- The carbody and crawler controls are on the front of the carbody



**FIGURE 1-1**

IDENTIFICATION AND LOCATION OF COMPONENTS

14COM1-2b  
14COM1-2f

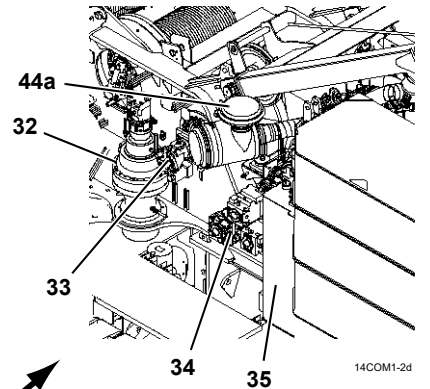
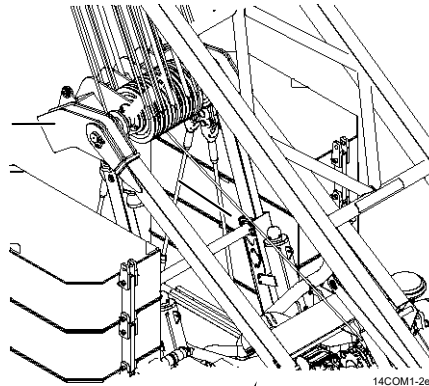


Item	Description
1	Upperworks
2	Undercarriage
3	Operator's Cab
4	Carbody Counterweight (both ends) (Series 3 shown)
5	Enclosures (both sides)
6	Crawler
7	Crane Counterweight (Series 3 shown)
8	Gantry
9	Boom Hoist Wire Rope
10	Mast Arms with Cylinders
11	Mast (Live)
12	Telescopic Boom Stop
13	Wire Rope Guide (Boom Butt)
14	Boom Butt
15	Drum 3 (Luffing Hoist or Auxiliary Load Drum)
16	Guide Sheaves (in Insert)
17	Inserts
18	Boom Straps
19	Load Lines
20	Load Block
21	Boom Top
22	Wire Rope Guide (Boom Top)
23	Upper Boom Point
24	Lower Boom Point
25	Weight Ball
26	Jib Point
27	Jib Top
28	Jib Butt
29	Jib Pendants
30	Jib Strut
31	Jib Backstay Pendants
32	Swing Drive
33	Drum 4 (Boom Hoist)
34	Pump Drive with Pumps
35	Hydraulic Tank
36	Gantry Cylinder (2 places)
37	Drum 2 (Rear Load Drum)
38	Drum 1 (Front Load Drum)
39	Boom Hinge Pins (with Cylinder)
40	Rotating Bed
41	Carbody Jack (4 places)
42	Carbody
43	Fuel Tank
44	Power Plant - Past Production Tier 3
44a	Air Cleaner
44b	Muffler

FIGURE 1-2

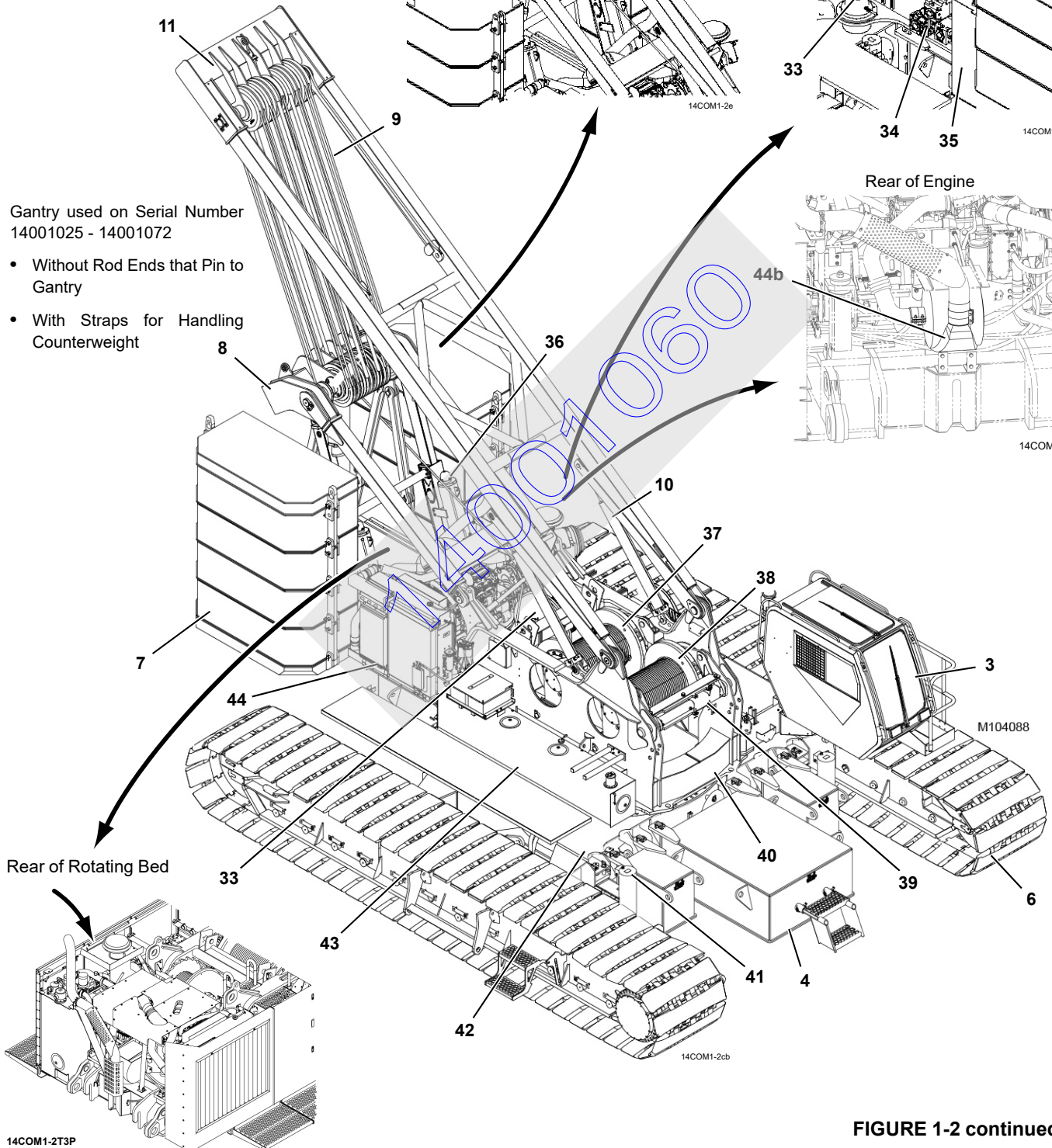
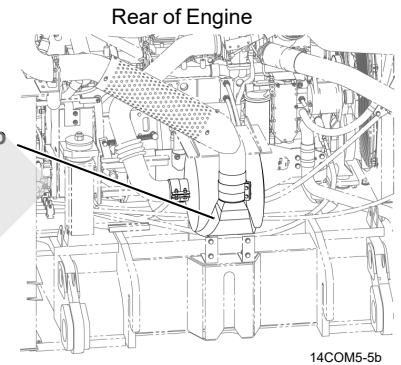
Gantry used on Serial Number 14001001 - 14001024:

- Without Rod Ends that Pin to Gantry
- With Pendants for Handling Counterweight



Gantry used on Serial Number 14001025 - 14001072

- Without Rod Ends that Pin to Gantry
- With Straps for Handling Counterweight



Rear of Rotating Bed

14COM1-2T3P

FIGURE 1-2 continued

14COM1-3c  
14COM1-3d

### OUTLINE DIMENSIONS

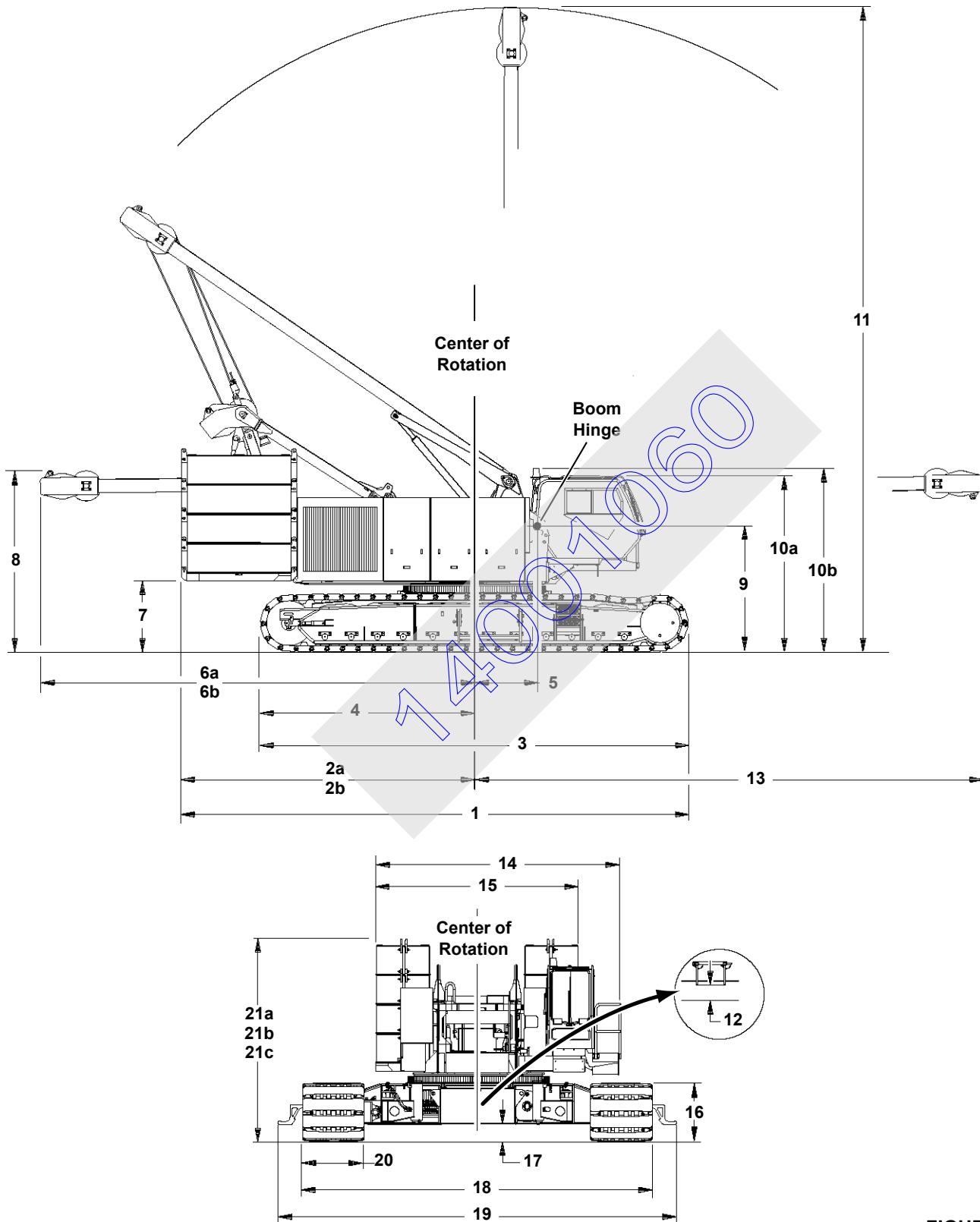


FIGURE 1-3

Item	Dimension
1	32 ft 3 in (9,83 m)
2a	18 ft 8 in (5,69 m) Overall Length
2b	19 ft 4 in (5,90 m) Counterweight Tail Swing
3	27 ft 3 in (8,30 m)
4	13 ft 8 in (4,16 m)
5	4 ft 0 in (1,22 m)
6a	27 ft 8 in (8,43 m) Overall Length
6b	27 ft 9 in (8,46 m) Mast Tail Swing
7	4 ft 6 in (1,37 m)
8	11 ft 7 in (3,53 m)
9	8 ft 0 in (2,44 m)
10a	11 ft 3 in (3,43 m) Top of Cab Rails
10b	11 ft 9 in (3,58 m) Top of Warning Light
11	40 ft 10 in (12,45 m)
12	0 ft 10 in (0,30 m) (bottom of step to ground)
13	32 ft 6 in (9,91 m) Overall Length
14	15 ft 7 in (4,75 m) with 20 in (508 mm) Wide Catwalk
14	15 ft 11 in (4,85 m) with 24 in (610 mm) Wide Catwalk
15	12 ft 11 in (3,94 m)
16	3 ft 9 in (1,15 m)
17	1 ft 1 in (0,33 m) (bottom of carbody to ground)
18	22 ft 3 in (6,79 m)
19	25 ft 4 in (7,73 m)
20	4 ft 0 in (1,22 m)
21a	11 ft 0 in (3,35 m) Series 1
21b	12 ft 11 in (3,94 m) Series 2
21c	13 ft 6 in (4,10 m) Series 3

FIGURE 1-3 continued

## ENGLISH AND METRIC CONVERSIONS

## Direct Conversion

MULTIPLY (x) known value by conversion factor to obtain equivalent value in desired units. For example, 12 ft is converted to meters (m), as follows:

$$12 \text{ ft} \times 0.3048 = 3,6576 \text{ m}$$

## Inverse Conversion

DIVIDE (÷) known value by conversion factor to obtain equivalent value in desired units. For example, 3,6576 m is converted to feet, as follows:

$$3,6576 \text{ m} \div 0.3048 = 12$$

To Convert	Symbol	Application	To	Symbol	Multiply By
<b>AREA</b>					
Square Inch	in <sup>2</sup>	Filter Area Clutch Contact	Square Centimeter	cm <sup>2</sup>	6.4516
Square Foot	ft <sup>2</sup>	Ground Contact	Square Meter	m <sup>2</sup>	0.0929
<b>FORCE</b>					
Pound Force	lb	Pedal Effort	KiloNewton Newton	kN N	0.00445 4.4482
Pound Force	lb	Line Pull	KiloNewton	kN	0.00445
Pound Force Per Inch	lb/in.	Spring Force	Newton per millimeter	Nmm	0.1751
Pound Force Per Foot	lb/ft		Newton per meter	Nm	14.5939
<b>LENGTH</b>					
Inch	in.	Adjustments	Millimeter	mm	25.4000
Foot	ft	Outline Dimensions	Meter	m	0.3048
Mile	miles	Travel Distance	Kilometer	km	1.6093
<b>POWER</b>					
Horsepower	hp	Engine	Kilowatt	kW	0.7457
<b>PRESSURE</b>					
Pound/Sq. In.	psi	Hydraulic & Air	Bar		0.0689
<b>TEMPERATURE</b>					
Degrees Fahrenheit	°F	Oil, Air, Etc.	Degrees Centigrade	°C	°F - 32 ÷ 1.8
Degrees Centigrade	°C		Degrees Fahrenheit	°F	°C x 1.8 + 32
<b>TORQUE</b>					
Inch Pound	in lb	Bolt Torque	Newton Meter	Nm	0.1129
Foot Pound	ft lb		Newton Meter	Nm	1.3558
<b>VELOCITY</b>					
Miles Per Hour	mph	Vehicle Speed	Kilometers Per Hour	km/h	1.6093
Miles Per Hour	mph	Wind Speed	Meters Per Second	m/s	0.4470
Feet Per Minute	fpm	Line Speed	Meters Per Minute	m/min	0.3048
<b>VOLUME</b>					
Cubic Yard	yd <sup>3</sup>	Bucket Capacity	Cubic Meter	m <sup>3</sup>	0.7646
Cubic Foot	ft <sup>3</sup>		Cubic Meter	m <sup>3</sup>	0.0283
Cubic Inch	in <sup>3</sup>	Pump Displacement	Cubic Centimeter	cm <sup>3</sup>	16.3871

To Convert	Symbol	Application	To	Symbol	Multiply By
<b>VOLUME (LIQUID)</b>					
Ounce	oz	Fluid Capacities	Milliliter	mL	29.5735
Pint	pt		Liter	L	0.4732
Quart	qt		Liter	L	0.9464
Gallon	gal		Liter	L	3.7854
Gallon Per Minute	gpm	Pump Flow	Liters Per Minute	L/min	3.7854
<b>WEIGHT</b>					
Pound	lb	Unit/Component	Kilogram	kg	0.4536
Ton (2,000 lb.)	USt	Load Ratings	Metric Ton	t	0.9072
Ton (2,000 lb.)	USt		Kilogram	kg	907.1847

14001060

***THIS PAGE INTENTIONALLY LEFT BLANK***

14001060



## SECTION 2

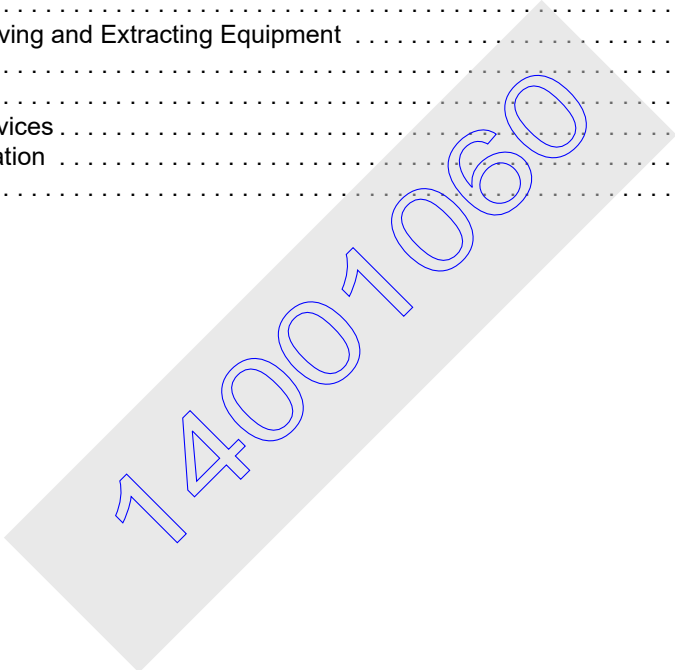
### SAFETY INFORMATION

#### TABLE OF CONTENTS

Continuous Innovation .....	2-1
Nameplates and Decals .....	2-1
Safety Messages .....	2-1
General .....	2-1
Safety Alert Symbol .....	2-1
Signal Words .....	2-1
Symbol Identification .....	2-1
Safety and Information Signs .....	2-3
Maintaining Signs .....	2-3
Ordering Signs .....	2-3
Crane Access Points .....	2-4
General .....	2-4
Getting On or Off Crane .....	2-4
Personal Fall-Protection .....	2-6
Operator Manual/Capacity Chart Storage .....	2-6
General .....	2-6
Storing Manuals .....	2-6
Swing Radius Barrier .....	2-7
Deploying Swing Radius Barrier .....	2-7
Storing Swing Radius Barrier .....	2-7
Safe Operating Practices .....	2-8
General .....	2-8
Work Area Control .....	2-8
Read Operator Manual .....	2-8
Operator Qualifications .....	2-8
Operator Conduct .....	2-9
Handling Load .....	2-10
Size of Load .....	2-10
Attaching Load .....	2-11
Lifting/Moving Load .....	2-11
Holding Load .....	2-12
Signals .....	2-12
Safety Devices .....	2-13
Operational Aids .....	2-13
Category 1 Operational Aids .....	2-13
Category 2 Operational Aids .....	2-14
Assembling, Disassembling, or Operating Crane Near Electric Power and Transmission Lines .....	2-15
Electrocution Hazard .....	2-15
Set-Up and Operation .....	2-15
Electrical Contact .....	2-16
Refueling .....	2-16
Fire Extinguishers .....	2-16
Accidents .....	2-16
Safe Maintenance .....	2-17
Maintenance Instructions .....	2-17
Safe Maintenance Practices .....	2-17
Environmental Protection .....	2-18
Boom Disassembly Safety .....	2-20
General .....	2-20
Location .....	2-20
Pin Removal .....	2-20

14001060

Disassembly Precaution .....	2-20
Special Application/Service .....	2-21
Personnel Handling Policy .....	2-21
Pedestal/Barge Mounted Cranes .....	2-22
Pedestal Mounted Crane .....	2-23
Definition .....	2-23
Examples .....	2-23
Barge Mounted Crane .....	2-23
Definition .....	2-23
Examples .....	2-23
Capacity Charts for Barge Mounted Crane .....	2-24
Shock Loading Caused by Barge Dynamics .....	2-25
Operation on Barge .....	2-25
Barge Mount Definitions .....	2-25
Inspection of Barge-Mounted Crane .....	2-25
Transporting Crane on Barge .....	2-26
Pile Driving and Extracting .....	2-26
Introduction .....	2-26
Operation of Pile Driving and Extracting Equipment .....	2-26
Crane Equipment .....	2-26
Crane Inspection .....	2-26
Electrocution Hazard Devices .....	2-27
Multiple Load Line Operation .....	2-27
Multiple Crane Lifts .....	2-28



## SECTION 2

### SAFETY INFORMATION



#### WARNING

##### California Proposition 65

Breathing diesel engine exhaust exposes you to chemicals known to the State of California to cause cancer and birth defects or other reproductive harm.

- Always start and operate the engine in a well-ventilated area.
- If in an enclosed area, vent the exhaust to the outside.
- Do not modify or tamper with the exhaust system.
- Do not idle the engine except as necessary.

For more information go to [www.P65warnings.ca.gov/diesel](http://www.P65warnings.ca.gov/diesel).

Batteries, battery posts, terminals, and related accessories can expose you to chemicals, including lead and lead compounds, which are known to the State of California to cause cancer and birth defects or other reproductive harm. Wash hands after handling. For more information go to [www.P65warnings.ca.gov](http://www.P65warnings.ca.gov).

##### California Spark Arrestor

Operation of this equipment may create sparks that can start fires around dry vegetation. A spark arrestor may be required. The owner/operator should contact local fire agencies for laws or regulations relating to fire prevention requirements.

### CONTINUOUS INNOVATION

Due to continuing product innovation, the information in this manual is subject to change without notice. If you are in doubt about any procedure, contact your Manitowoc dealer or Manitowoc Product Support.

### NAMEPLATES AND DECALS

See the drawing at the end of this section.

### SAFETY MESSAGES

#### General

The importance of safe operation and maintenance cannot be over emphasized. Carelessness or neglect on the part of operators, job supervisors and planners, rigging personnel,

and job site workers can result in their death or injury and costly damage to the crane and property.

To alert personnel to hazardous operating practices and maintenance procedures, safety messages are used throughout the manual. Each safety message contains a safety alert symbol and a signal word to identify the hazard's degree of seriousness.

#### Safety Alert Symbol



This is the safety alert symbol. It is used to alert you to potential personal injury hazards. **Obey all safety messages that follow this symbol to avoid possible death or injury.**

#### Signal Words



#### DANGER

Indicates a hazardous situation which, if not avoided, will result in death or serious injury.



#### WARNING

Indicates a hazardous situation which, if not avoided, could result in death or serious injury.



#### CAUTION

Used with the safety alert symbol, indicates a hazardous situation which, if not avoided, could result in minor or moderate injury.

#### CAUTION

Without the safety alert symbol, identifies potential hazards that could result in property damage.

**NOTE** Highlights operation or maintenance procedures.

#### Symbol Identification

Many of the symbols used in the safety and information signs and nameplates on this crane are identified in [Table 2-1 on page 2-2](#) and [Table 2-2 on page 2-3](#).

Table 2-1 Common Safety Symbols





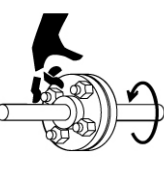


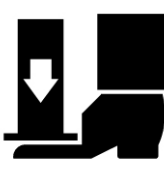







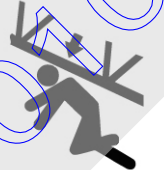






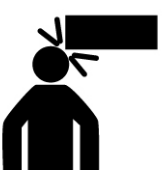


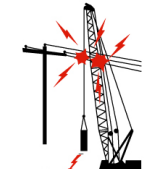


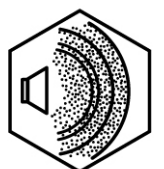

<b>Cut or Crush Hazards</b>					<b>Cut Hazard</b>
 M100090	 M100091	 M100066	 M100065	 M100069	 M100067
<b>Crush Hazards</b>					<b>Fire Extinguisher</b>
 M100070	 M100071	 M100072	 M100073	 M100074	 M100082
<b>Fall Hazards</b>			<b>Falling Boom (Crush) Hazards</b>		<b>Explosion Hazard</b>
 M100083	 M100084	 M100085	 M100068	 M100075	 M100080
<b>Falling Load Hazards</b>		<b>Flying Objects Hazards</b>			<b>Overhead Obstruction Hazard</b>
 M100076	 M100077	 M100088	 M100088	 M100089	 M100081
<b>Electrocution Hazards</b>		<b>Personal Fall Protection</b>	<b>Pressure Cleaning</b>	<b>Sound Power Level</b>	<b>Read Manual</b>
 M100078	 M100079	 M100095	 M100087	 M100096	 M100093

Table 2-1 Common Safety Symbols











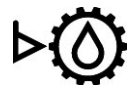

Emergency Cab Exit	Lift	Do Not Lift	Prohibited
 M102486	 M104626	 M104627	 M104628

Table 2-2 Miscellaneous Symbols

Diesel Fuel	Engine Coolant	Engine Coolant Vent	Engine Oil Level	Hydraulic Filter	Hydraulic Oil
 M100271	 M100267	 M100268	 M100269	 M100272	 M100273
<b>Pump Drive Oil Level</b>	<b>Tire Pressure (if equipped)</b>				
 M100270	 M100266				

### SAFETY AND INFORMATION SIGNS

#### Maintaining Signs

The crane owner/user shall make sure that all safety and information signs are legible and installed at the proper locations on the crane. If a sign has been defaced or removed, it must be replaced immediately. See the Nameplate and Decal Drawing at the end of this section for the installation locations of signs.

#### Ordering Signs

Order replacement safety and information signs from your Manitowoc dealer.

When ordering a sign, give the crane model number, the crane serial number, and the name and part number of the sign.

## CRANE ACCESS POINTS



### WARNING

#### Crush Hazard!

The upperworks can swing into and crush personnel climbing on or off the crane.

Moving crawlers can crush personnel climbing on or off the crane.

To prevent death or serious injury:

- Barricade all accessible areas to the crane so personnel cannot be struck or crushed when the upperworks is swung.
- Do not climb onto or off the crane while the upperworks is being swung or the crane is being traveled.
- Signal the operator for permission to climb onto/off the crane.
- Operator: do not swing or travel while personnel are climbing onto or off the crane. Stop the swing and travel motions. Apply the swing brake and turn on travel park.
- Operator: Always sound the horn to alert personnel before you swing or travel.
- Automatic alarms will sound to alert personnel when the crane is swung or traveled.

**NOTE** If the swing and travel alarms are not operating properly, they must be repaired as soon as possible. Until they are repaired, the operator shall alert personnel to crane movement using the horn on the control console.

## General

Take necessary precaution to prevent slipping and/or falling off the crane during assembly, disassembly, maintenance, or other work. **Falling from any height could result in serious injury or death.**

Manitowoc has provided a ladder, steps, platforms, and catwalks at the locations shown in

The owner/user shall provide workers with approved ladders or aerial work platforms to access those areas of the crane, gantry, and boom that cannot be reached from the ground or from the ladder, steps, platforms, and catwalks provided by Maniowoc.

Adhere to local, state, and federal regulations for handling personnel and for personnel fall protection.

- Access points must be kept clear to prevent personal injury and unsafe operation of the crane. Store clothing and other personal belongings so they do not interfere with controls in operator cab or with operation of the crane.
- Do not allow ground personnel to store their personal belongings (clothing, lunch boxes, water coolers, and the like) on the crane.

This practice will prevent ground personnel from being crushed or electrocuted when they attempt to access personal belongings stored on the crane.

- Tools, oil cans, spare parts, and other necessary equipment must be stored in tool boxes or other appropriate locations. Do not allow these items to lie around loose in operator cab or on steps, ladders, catwalks, and platforms.
- To reduce risk of slipping, non-skid material (sand in paint) has been applied to painted walkways and platforms.
- Walkways and platforms can be slippery when wet and when oil or grease is spilled on them. **Keep walkways and platforms clean and dry to prevent slipping on them.** When non-skid material wears out, reapply it.
- Wear shoes with a highly slip-resistant sole material. Clean any mud or debris from shoes before entering the crane cab or climbing onto the cab. A shoe that is not clean might slip off a control pedal during operation.
- Do not make modifications or additions to the crane's access system that have not been evaluated and approved by Maniowoc.

## GETTING ON OR OFF CRANE

Personnel getting on and off the crane shall do so only:

- a. at the steps or ladders provided,
- b. while crane is parked and not moving,
- c. with the operator's or qualified person's permission,
- d. if the performance of their duties requires them to do so.

When personnel use the steps and ladders to get on or off the crane, their hands shall be free of any objects. Objects which cannot be carried in pockets or tool belts shall be lifted into place with a hand line or hoist.

Always maintain a three-point contact with the ladder: two feet and one hand or two hands and one foot.

Item	Description
1	Platforms (removable)
2a	Enclosure Panel (hinged)
2b	Enclosure Panel (removable)
3	Step (both crawlers)
4	Step (operator's cab)
5	Catwalk (operator's cab)
6	Carbody Counterweight (has non-skid surface)
7	Step (both Carbody counterweights)
8	Platform (between drums)
9	Steps (behind enclosure panel)
10	Ladder (rotating bed)
11	Counterweight Boxes and Tray (have non-skid surface)
12	Catwalk (boom butt)
13	Platforms (boom butt)

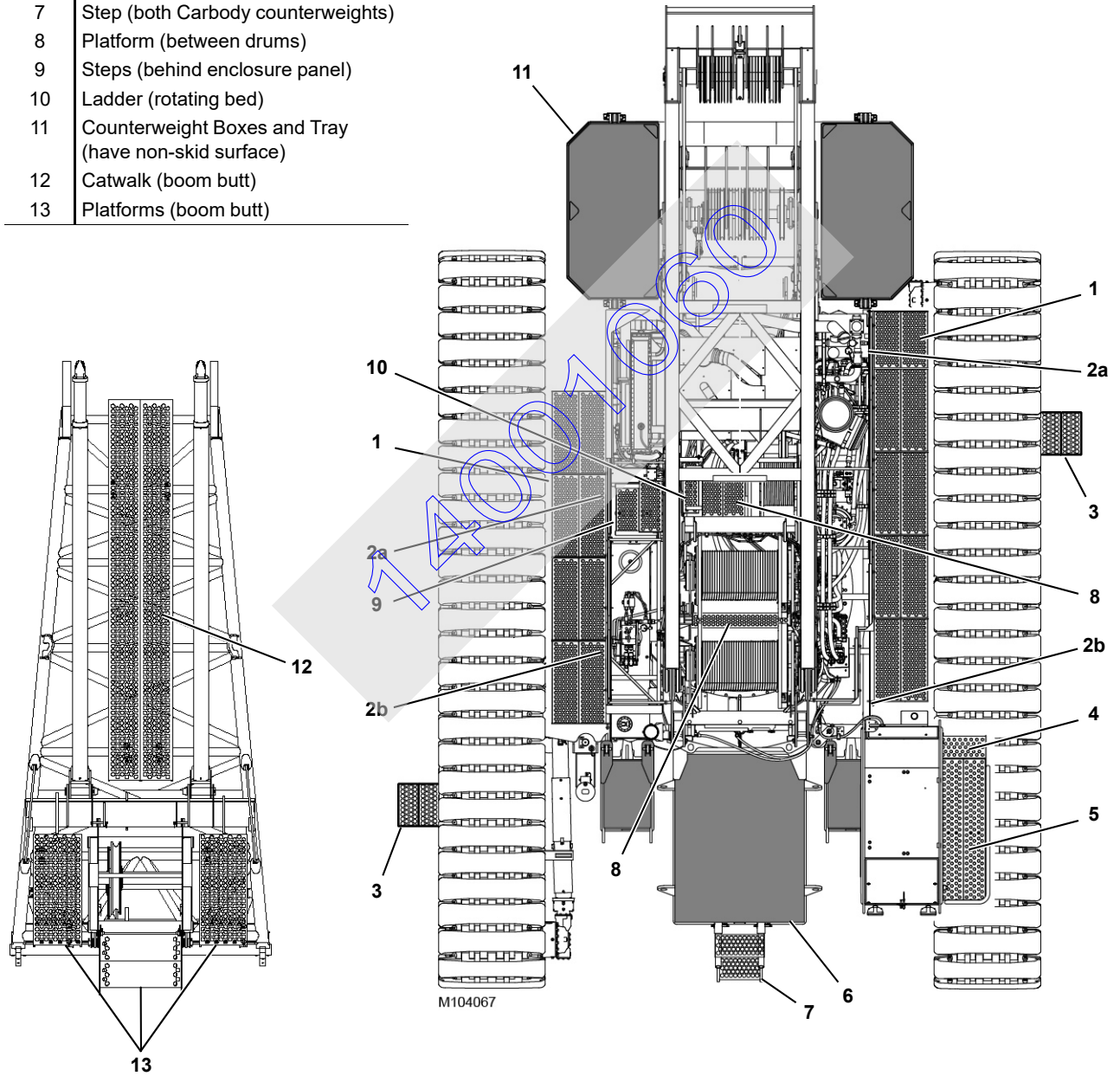


Figure 2-1. Crane Access Points



## PERSONAL FALL-PROTECTION

It is the crane owner/user's responsibility to provide assembly/maintenance personnel with appropriate fall-protection equipment.

### **WARNING** **Fall Hazard!**

To prevent falling from any height during crane assembly and disassembly, personnel shall appropriate wear fall-protection equipment.

## OPERATOR MANUAL/CAPACITY CHART STORAGE

### General

Manitowoc provides the following manuals and other important literature with your crane:

- **Operator Manual (Serial Numbered)**  
Contains safety information, crane specifications, assembly/erection procedures, operating instructions, lubrication and maintenance checks.
- **Parts Manual (Serial Numbered)**  
Contains illustrations and part numbers of replaceable parts.
- **Capacity Chart Manual (Serial Numbered)**  
Contains lifting capacities and related information (wire rope specifications, drum and lagging information, etc.).
- **Maintenance Checks and Lube Guide**  
Contains lists of maintenance checks and lube services and their prescribed intervals.
- **RCI/RCL Operation**  
Contains rated capacity indicator and/or rated capacity limiter operation, limits, and calibration procedures.
- **Service Manual (Serial Numbered)**  
Contains theory of operation, maintenance procedures, crane and wire rope inspection procedures, troubleshooting information, and shop procedures.

The manuals which must be retained in the operator cab (Operator Manual, Capacity Charts, Maintenance Checks and Lube Guide, and RCL Operation) are supplied in an OPERATOR INFORMATION binder.

The Operator Manuals and Capacity Charts are stamped with the serial number of the crane or attachment. The serial number on the manuals and capacity charts must match the serial number of the crane. **Using any other manual or capacity chart is prohibited.**

The crane model and serial number are located on the Crane Identification Plate on the crane cab.

If the serial numbers of your manuals and capacity charts do not match the serial numbers of the crane, contact your Manitowoc dealer for the proper manual or capacity charts.

**Do not operate the crane if the proper Capacity Chart is not in the cab.**

### Storing Manuals

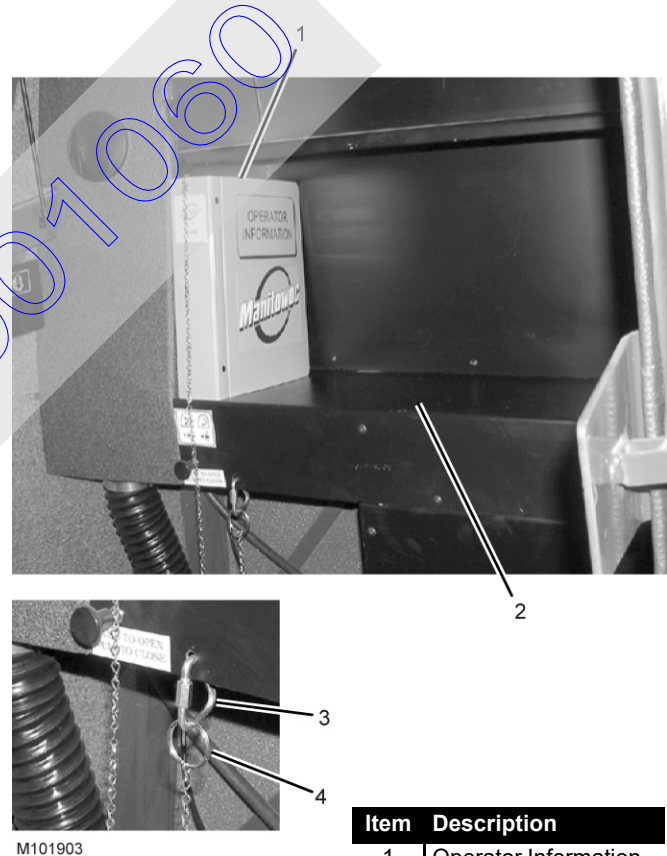
See [Figure 2-2](#).

Store the Operator Information binder in the holder (3) located behind the seat (1) in the left rear corner of the operator cab.

Attach the chain from the manual to the link (4) on the holder.

Keep all other manuals provided with the crane in the crane owner's/user's office so they are readily available when needed.

Additional storage is provided on the storage shelves (2).



Item	Description
1	Operator Information Manual
2	Bookshelf Behind Operator Seat
3	Link
4	Chain Ring

**Figure 2-2. Manual Holder in Cab**

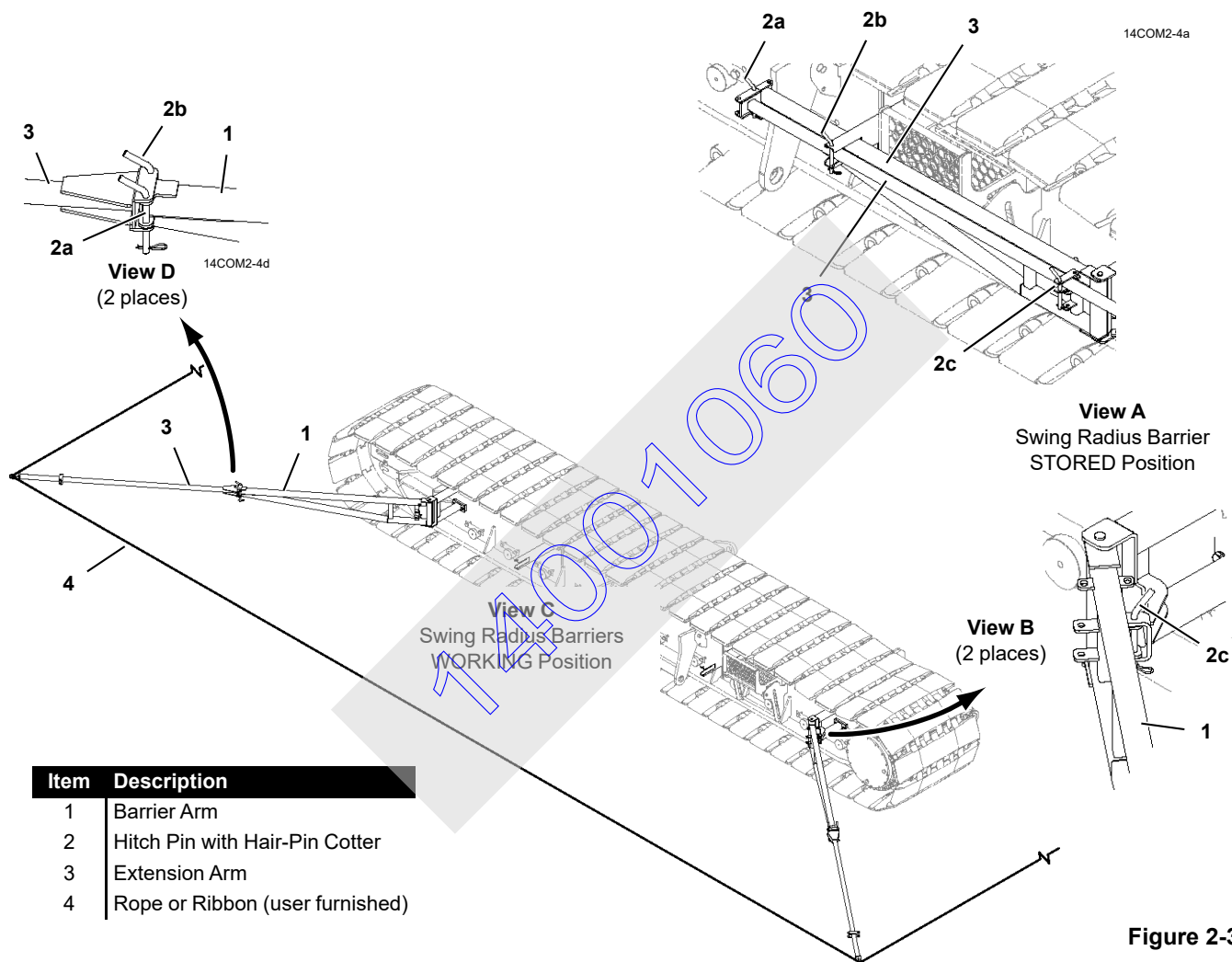


## SWING RADIUS BARRIER

Manitowoc's optional swing radius barrier is shown in [Figure 2-3](#).

**⚠ WARNING**  
**Crush Hazard!**

To prevent personnel from being crushed by swinging crane, deploy swing radius barrier before operating crane.



Item	Description
1	Barrier Arm
2	Hitch Pin with Hair-Pin Cotter
3	Extension Arm
4	Rope or Ribbon (user furnished)

Figure 2-3.

### Deploying Swing Radius Barrier

1. Remove pins (2b and 2c, View A) from stored position.
2. Unfold extension arms (3) and rotate barrier arms (1) outward to working position (View C).
3. Install pins (2b, View D and 2c, View B) to secure arms in working position.
4. Form a safety perimeter by attaching user supplied high visibility rope or ribbon (4) to hooked ends of extension arms (3, View C).

### Storing Swing Radius Barrier

1. Remove rope or ribbon (4) from hooked ends of extension arms (3).
2. Remove pins (2b, View D and 2c, View B) from working position.
3. Fold extension arms (3) and rotate barrier arms (1) inward against crawler frame.
4. Install pins (2b and 2c, View A) in stored position.

## SAFE OPERATING PRACTICES

### General

The importance of safe operation cannot be over emphasized. Carelessness and neglect on the part of operators, supervisors and planners, rigging personnel and job site personnel can result in their death or injury and costly damage to the crane or property.

The safety information in this publication is intended only as a guide to assist qualified operators, supervisors and planners, rigging personnel, and job site personnel in safe operation. Manitowoc cannot foresee all hazards that will arise in the field; therefore, **safety remains responsibility of crane operators and owner.**

Local, state, and other governmental agencies may require stricter operating practices. When a conflict in practices exists, follow the strictest practice.

### Work Area Control

Personnel within the swing radius of the crane and fall zone of the crane's boom and/or load are subject to hazards if the crane is not operated per the requirements of the manufacturer and industry recognized safe operating practices.

To minimize the risk of harm, training of personnel on jobsite hazard recognition and prevention is required. Additionally, restricting access to the swing radius and fall zone during specific work conditions is required. The U.S. Department of Labor, Occupational Safety and Health Administration (OSHA) regulations for Construction provides requirements in 29CFR1926.1417 Operation, 29CFR1926.1424 Work area control, 29CFR1926.1425 Keeping clear of the load and 29CFR1926.1426 Free fall and controlled load lowering.

### Read Operator Manual

Safe and efficient assembly, disassembly, and operation of this crane requires that it be maintained in proper working order and that its operators and maintenance personnel be familiar with the crane's functions and capabilities.

The Operator Manual supplied with and considered part of your crane must be read and completely understood by each person responsible for assembly, disassembly, operation, and maintenance of the crane.

The Operator Manual must be read to personnel who cannot read or understand English or other language into which the manual is translated.

Because of a program of continuing improvement in product design, Manitowoc reserves the right to change the information and specifications contained in the Operator

Manual at any time without notice. If you have any questions regarding the crane or its Operator Manual, please contact your Manitowoc dealer or Manitowoc Product Support.

### Operator Qualifications

The crane must be operated only by the following **qualified** personnel:

1. Designated operators.
2. Trainees under direct supervision of a designated operator.
3. Supervisors, inspectors, and maintenance or test personnel when necessary in performance of their duties. Operation of the crane by these personnel shall be limited to the crane functions needed to perform the inspection or to verify the crane's performance after maintenance procedures.

**No personnel shall be allowed to climb onto the crane or enter cab unless performance of their duties requires them to do so, and then only with knowledge of operator or other qualified person.**

**Qualified person** is defined as one who by reason of training and experience is thoroughly familiar with crane operations and the hazards involved. Such a person shall meet the operator qualifications specified in Occupational Safety and Health Administration (OSHA) Regulations (United States Federal Law), in ASME B30.5 American National Standard, or in any other applicable federal, state, or local laws.

**Operator training and qualification is crane owner's responsibility.**

**NOTE** The regulations and standards mentioned above and later in this section can be obtained from:

**US DOL/OSHA** Rules and Regulations are available by mail from the Superintendent of Documents, PO Box 371954, Pittsburgh, PA, 15250-7954 or by:

- Phone 202-512-1899
- Fax 202-512-2250
- Online at [www.osha.gov](http://www.osha.gov)

**ASME** (formerly ANSI) B30 Series American National Standards are available by mail from the ASME, 22 Law Drive, Fairfield, New Jersey, 07004-2900 or by:

- Phone US & Canada 800-843-2763
- Phone Mexico 95-800-843-2763
- Phone Universal 973-882-1167
- Fax 973-882-1717 or 973-882-5155

- E-mail [infocentral@asme.org](mailto:infocentral@asme.org)

## Operator Conduct

1. The operator shall not engage in any practice which diverts his/her attention while operating the crane.
2. The operator shall not operate the crane when he/she is physically or mentally unfit.
3. The operator shall be responsible for all operations under his/her direct control. When safety of an operation is in doubt, the operator shall stop the crane's functions in a controlled manner. Lift operations can resume only after safety concerns have been addressed or the continuation of crane operations is directed by the lift supervisor.
4. The operator shall be thoroughly familiar with operation of the crane and its proper care. If adjustments or repairs are necessary or if there are known defects that impair safe operation, the crane must not be operated until unsafe conditions have been corrected.
5. If there is a warning sign at the start controls, the operator shall not start the engine until the warning sign has been removed by the person who installed it.
6. Before starting the engine, the operator shall make sure that:
  - a. All daily inspection and maintenance services have been performed.
  - b. All controls are in the off position and all brakes and locking devices are applied or engaged.
  - c. All personnel are clear of the crane. Deploy a swing radius barrier.
7. The operator shall test all controls, limits, and communication systems at the start of each shift. Any defects found must be corrected before operation is begun.
8. The operator shall not start crane movement if the load or designated signal person is not within his/her range of vision or communication.
9. The operator shall understand and respond to signals from the person directing the lift or from the designated signal person. When a signal person or crane follower is not required, the operator is responsible for the lift. **Operator shall obey a stop signal at all times, no matter who gives it.**
10. The operator shall verify that the Capacity Chart being used is the correct one for the cranes configuration (boom length, load line reeving, counterweight, etc.).
11. The operator shall verify that:
  - a. All attachments are properly assembled and attached to the crane according to the rigging drawings called for in the Capacity Chart.
  - b. The counterweight — to include applicable auxiliary counterweight — is in place and of proper weight. **Maximum required counterweight must not be exceeded.**



### WARNING

Safety devices and operational aids such as rated capacity indicator or limiter, boom and jib angle indicator or limiter, anti-two-block device, level indicator, swing limiter, proximity device, etc., may be installed on your crane. Such devices are to be used only as **AIDS TO ASSIST OPERATOR**; their presence on the crane in no way substitutes for or lessens requirement that operator knowledge, experience, and judgment are required to ensure safe operation of the crane.

**Crane must not be loaded beyond applicable static or dynamic ratings given in Capacity Chart for crane.**

- See Size of Load later in this section.
- For a description of each safety device and operational aid, see Section 3 of the MLC100-1 Operator Manual.



### WARNING

#### Moving Load/Tipping Crane Hazard!

Changing weather conditions including, but not limited to: wind, ice or snow accumulation, precipitation, flooding, lightning, etc. should be considered when determining the location and configuration of a crane when it will be left unattended.

12. The operator shall perform the following operations before leaving the operator cab for any reason:
  - a. Park the crane and position upperworks so the crane does not interfere with operation of other equipment.
  - b. Apply travel and swing brakes or locking devices.
  - c. Land any attached load.
  - d. Lower the boom onto blocking at ground level or onto a boom rest if possible.

If the boom cannot be lowered, as determined by a qualified designated person, it must be securely fastened from movement by wind or other outside forces (see Wind Conditions in Capacity Chart Manual).

**NOTE** The designated person shall be familiar with the job site limitations, the crane configuration, and the expected weather conditions.

- e. Move all controls to off.
- f. Apply all drum brakes and pawls.
- g. Disengage the master clutch, if equipped.
- h. Stop the engine.

**NOTE** Also read Unattended Crane instructions in Section 3 of the Crane Operator Manual.

**13.** The operator shall perform the following operations if power or a control function fails during operation:

- a. Land all suspended loads, if possible, under brake or power control.
- b. Apply all brakes and locking devices.
- c. Move all controls to off.

**14.** If the crane will be operated at night, the operator shall make sure that there is sufficient lighting for safe operation. The load and landing area must be illuminated.

**15.** The operator shall not operate the crane during periods of bad weather if his/her ability to see the load or the signal person is impaired by darkness, fog, rain, snow, and the like.

Do not operate the crane with a snow or ice covered boom. The extra weight may cause overload, tipping, or structural damage.

Never operate the crane during an electrical thunderstorm.

When a local weather storm warning exists (including electrical thunderstorm), stop operation and secure the crane. See step [12](#) on [page 2-9](#).

**NOTE** DO NOT depend on grounding. Grounding of a crane affords little or no protection from electrical hazards. The effectiveness of grounding is limited by the size of the conductor (wire) used, condition of the ground, the magnitude of voltage and current present, and numerous other factors.

**16.** Wind can cause the crane to tip or the boom and other attachments to collapse. The operator or qualified person directing the lift shall compensate for the effect of wind on the load and boom by reducing ratings, reducing operating speeds, or a combination of both.

Unless otherwise specified in the Capacity Chart, or Operator Manual, stop operation under the following wind conditions:

- a. If the wind causes the load to swing forward past the allowable operating radius or sideways past either

boom hinge pin, land the load and apply the drum brakes.

- b. If the wind exceeds 16 m/s (35 mph), land all loads and apply the drum brakes, lower the boom onto blocking at ground level or otherwise restrain it, and apply the swing and travel brakes and/or locks.

**NOTE** “*Land load*” means to set it down on a firm uniformly supporting surface.

**17.** Booms, jibs, or masts which are being assembled or disassembled on the ground (with or without support of boom rigging) must be securely blocked to prevent the boom, jib, or mast sections from dropping.

**Workers shall not go under boom, jib, or mast sections when removing connecting pins or bolts.**

**18.** Each outrigger must be visible to the operator or the signal person during extension and retraction.

## Handling Load

### Size of Load

1. The crane must not be loaded beyond the applicable static or dynamic ratings given in the Capacity Chart for the crane configuration.
2. The ratings given in the Capacity Chart are developed based on “Freely suspended loads” and specified operating conditions. When cranes are used for service other than lifting service and/or special lifting operations, Manitowoc or a qualified person shall establish the ratings, operating limitations, maintenance, testing, and inspection requirements. Please reference Special Application/Service later in this section.

**NOTE** “*Freely suspended load*” is a load that is hanging free with no direct external force applied except by the crane’s load-line reeving.

To determine the actual weight of the load which can be lifted at a given radius (working load), the operator shall deduct the weight of certain lifting equipment from the total weight given in the chart. See the specific Capacity Chart for your crane for a list of lifting equipment which must be deducted.

The operator’s judgment shall be used to further reduce total load to allow for the dynamic effects of swinging, hoisting, or lowering, and adverse weather conditions to include wind.

3. The operator or other designated person directing the lift shall verify that the weight of load is within the static or dynamic rating for radius at which load will be lifted.

**Verified weights and measured radii must take priority over RCI/RCL readings.**

### Attaching Load

1. Attach the hook to the load with slings, or other suitable rigging. Each hook must have a latch that is in proper working order. **Hook latches must not be wired open.**
  - a. Inspect each hook and latch before using.
  - b. Never use a hook or latch that is distorted or bent.
  - c. Make sure spring will force the latch against the tip of the hook.
  - d. Make sure the hook supports the load. The latch must never support the load. Latches are only intended to retain loose slings under slack conditions.
2. Only use slings and other rigging that are in safe operating condition and have a rating equal to or greater than the load to be lifted.
3. Do not wrap the load line around the load.
4. Use suitable protection between slings and any sharp edges on the load. When synthetic slings are used, the synthetic sling manufacturer's instructions, limitations, specifications, and recommendations must be followed.
5. Secure unused legs of a multi-leg sling before handling a load with one leg of sling.

### Lifting/Moving Load

1. Before lifting or moving a load, the operator or qualified person directing the lift shall make the following checks.
  - a. Crane has a firm, uniformly supporting foundation under all crawlers. Unless otherwise specified in the Capacity Chart, the foundation must be level to within 1% — 0,3 m (1ft) rise or fall in 30,3 m (100 ft) distance.  
  
When such a surface is not available, it must be provided with timbers, cribbing, or other structural members to distribute the load such that the allowable bearing capacity of the underlying member is not exceeded.  
  
For ground bearing data go to: [www.manitowoc.com](http://www.manitowoc.com)
  - b. The load is secured and properly balanced in the slings or the lifting device before lifting the load more than 76 to 152 mm (3 to 6 in).
  - c. The lift and swing paths are clear of personnel and obstructions.
  - d. The load is free to be lifted.
  - e. The load line is not kinked or otherwise damaged.
  - f. Multiple part load lines are not twisted around each other in such a manner that the lines will not separate when the load is lifted.

- g. The hook is brought over the load in a manner that will minimize twisting or swinging.
  - h. The load line and the boom hoist rope are properly spooled on the drums and seated in the sheaves.
  - i. The load drum brakes are in proper working order.  
  
The operator shall test the load drum brakes each time a load approaching the rated load is handled. Lift the load 76 to 152 mm (3 to 6 in) and fully apply the brakes — load must not lower through applied brakes.
  - j. Unused load drums are parked (working and parking brakes applied; if equipped, drum pawls engaged).
  - k. All personnel are clear of the swing radius of the crane's counterweight.
2. While lifting or moving the load, the operator shall take the following precautions:
    - a. Accelerate and decelerate the load smoothly to avoid excessive stress on the boom and machinery.
    - b. Avoid sudden starts and stops while swinging. Keep the swing speed under control to prevent the load from swinging out beyond the radius at which the load can be handled and to minimize the pendulum action of the load.
    - c. When lifting, any non-vertical loads applied to the crane from dynamics, multi-crane lifts or environmental factors must be minimized or eliminated. The load must remain under the lifting point at all times.
    - d. Sound the signal horn before swinging and intermittently while swinging, especially when approaching personnel.  
  
If equipped, the automatic swing alarm will sound when the crane is swung.
    - e. Use taglines or other restraints to control the load when necessary.
    - f. Do not exceed any swing limitations (areas of operation) given in the Capacity Chart.
    - g. Do not allow the load, boom, or any other part of the crane to contact obstructions.
    - h. Do not use the crane to drag a load.
    - i. Do not hoist, lower, or swing the load while personnel are on the load or the hook. See Personnel Handling in this section.
    - j. Avoid carrying the load over personnel. Loads which are suspended must be blocked or cribbed before personnel are allowed to work under or between them.



- k. Before lifting a load which requires the use of outriggers (or anytime outriggers are used), fully extend the outrigger beams and jacks so the truck tires do not bear any load.

Securely fasten the outrigger jack pads or floats to jacks and set them on a flat, firm surface that will support the load placed on the pads or floats. Do not set the jack pads or floats in holes, on rocky ground, or on extremely soft ground.

When dictated by ground conditions, install wood blocking or steel plates under the jack pads or floats to properly distribute the loading on the supporting surface.

Wood blocking or steel plates used under the jack pads or floats must be:

- Free of defects
- Strong enough to prevent crushing, bending, or shear failure
- Of sufficient thickness, width, and length to completely support the jack pad or float, transmit the load to the supporting surface, and prevent shifting, toppling, or excessive settlement under load.

- l. Fully retract and lock the jacks and the outrigger beams so they cannot extend when not in use.

- m. Do not lower the load or the boom to a point where less than three full wraps of wire rope remain on the respective drum (or as otherwise indicated in local, state, or federal regulations).

- n. Engage the boom hoist pawl when operating with the boom at a fixed radius.

- o. Engage the luffing hoist pawl when operating with the luffing jib at a fixed radius.

- 3. While traveling, the operator shall take the following precautions:

- a. Sound the signal horn before traveling and intermittently while traveling, especially when approaching personnel.

If equipped, the automatic travel alarm will sound when the crane is traveled.

- b. Carry the boom in-line with the lowerworks and facing the direction of travel.

- c. Do not position the boom so high that it could bounce over backwards whether traveling with or without load.

- d. Secure the rotating bed against rotation except when it is necessary to negotiate a turn, and then only when the operator is seated at controls or the boom is supported on a dolly.

- e. Lash or otherwise restrain unused hooks so they cannot swing freely.

- 4. Before traveling with a load, the operator shall take the following additional precautions:

- a. A designated person shall be responsible for operation. Decisions such as the necessity to reduce crane ratings, load position, boom position, ground support, and speed of movements must be in accordance with the designated person's decision.

- b. Maintain specified tire pressures (truck cranes).

- c. Avoid sudden starts and stops. Use taglines or other restraints to control the position of the load.

### **Holding Load**

When a load is suspended, the operator shall take the following precautions:

1. Not leave his/her position at the controls
2. Not allow personnel to stand or pass under the load
3. Move all controls to off, apply all drum brakes, engage the boom hoist pawl, and apply the swing and travel brakes or locks.

### **SIGNALS**

1. Continuous communication must be maintained between the operator and the signal person during all crane movements. If communication is disrupted, **operator shall stop all crane movements.**

2. Signals to the operator must be in accordance with the standard signals shown in Section 3, unless communications equipment (telephone, radio, etc.) is used.

3. All signals must be easily understood by the operator at all times. The operator shall not respond to any signal which is not clearly understood.

4. For operations not covered in the standard signals, or for special situations or emergencies, additional signals may be required. In those cases, the signals used must be agreed upon in advance by the operator and the signal person. The signals used must not conflict with or have potential to be confused with the standard signals.

5. When it is necessary to give instructions to the operator (other than those established by the signal system), all crane motions must be stopped.

6. The signal person shall:

- a. Be tested by a designated person and show that he or she has a basic understanding of crane operations and limitations, to include boom deflection.

- b. Be thoroughly familiar with the standard hand signals and voice signals if used.
  - c. Be positioned in clear view of the operator. The signal person's position should give him or her a clear view of the load, the crane, and the operating area.
  - d. Direct the load so it does not pass over personnel.
  - e. Keep unnecessary personnel out of the crane's operating area.
7. When moving the crane, the following audible signals must be used:
- a. STOP - one short audible signal
  - b. GO AHEAD - two short audible signals
  - c. BACK UP - three short audible signals
3. Cranes operating on a barge require: a trim indicator, a swing brake, and a wind direction indicator if the wind is a factor (supplied by crane owner or user).
  4. Boom stops, both physical and automatic  
If a boom stop is damaged or not working properly, it must be tagged-out or removed if possible.
  5. Jib stops, both physical and automatic (for fixed jib and luffing jib)  
If a jib stop is damaged or not working properly, it must be tagged-out or removed if possible.
  6. Pedal locks for all foot-operated brakes (if applicable)  
If a pedal lock is damaged or not working properly, it must be tagged-out or removed if possible.
  7. An integral holding device or check valve on each jacking cylinder.

## SAFETY DEVICES



### WARNING

Do not operate the crane unless all safety devices listed in this section are in proper working order.

- If a safety device stops working properly during operation, the operator shall safely stop operation.
- If any safety device listed in this section is not in proper working order, the safety device must be taken out of service and crane operation must not resume until the safety device is again working properly.
- Alternative measures are not permitted to be used for a faulty safety device.
- Always tag-out any faulty safety device and place a warning tag in the cab stating that the crane is out of service and must not be used.

Manitowoc provides the following safety devices on its cranes.

1. Horn activated by a switch on the control console in the operator cab  
If the horn is not working properly, it must be tagged-out or removed if possible.
2. Crane level indicator: either electronic (viewable in crane's electronic display) or mechanical (viewable from operator cab seat). If the crane level indicator is not working properly, it must be tagged-out or removed, if possible.

## OPERATIONAL AIDS



### WARNING

Do not operate the crane unless all applicable operational aids listed in this section are in proper working order, except:

- Where an operational aid is being repaired
- The crane user implements a specified temporary alternative measure.

If an operational aid stops working properly during operation, the operator shall safely stop operation until the temporary alternative measures are implemented or the device is again working properly.

Manitowoc provides the following operational aids on its cranes, either as standard equipment or optional equipment. The operational aids are designated as Category 1 or Category 2:

### Category 1 Operational Aids

If a Category 1 operational aid is not working properly, it must be repaired no later than 7 calendar days after the deficiency occurs.

Exception: If the crane user documents that he/she has ordered the necessary parts within 7 calendar days of the occurrence of the deficiency, the repair must be completed within 7 calendar days of receiving the parts.

### 1. Boom or Luffing Jib Angle Limiter

(automatic boom or jib stop)

Temporary alternative measures if inoperative or malfunctioning:

The qualified person directing the lift shall make sure the maximum boom or jib angle/radius specified in the Capacity Chart for the load being handled is not exceeded. One or more of the following methods must be used:

- a. Measure radius using a tape measure.
- b. Measure the boom angle with a protractor-level on the centerline of boom.
- c. Clearly mark the boom or luffing hoist cable (so it can easily be seen by the operator) at a point that gives the operator sufficient time to stop the boom or jib within the minimum allowable radius.

In addition, install mirrors or remote video cameras and displays if necessary for the operator to see the mark.

- d. Clearly mark the boom or luffing hoist cable (so it can easily be seen by a designated signal person) at a point that gives the signal person sufficient time to signal the operator and have the operator stop the boom or jib within the minimum allowable radius.

### 2. Anti-Two-Block Device

Temporary alternative measures if inoperative or malfunctioning:

The qualified person directing the lift shall establish procedures to furnish equivalent protection. One or more of the following methods must be used:

- a. Assign a signal person to signal the operator to stop hoisting when the load is a safe distance from the boom or jib point.
- b. Clearly mark the hoist cable (so it can easily be seen by the operator) at a point that will give the operator sufficient time to stop the load a safe distance from the boom or jib point.

The temporary alternative measures for the anti-two-block device do not apply when lifting personnel in load line supported baskets.

**Personnel shall not be lifted in load line supported baskets when anti-two-block devices are not functioning properly.**

## Category 2 Operational Aids

If a Category 2 operational aid is not working properly, it must be repaired no later than 30 calendar days after the deficiency occurs.

Exception: If the employer documents that he/she has ordered the necessary parts within 7 calendar days of the occurrence of the deficiency, and the part is not received in time to complete the repair in 30 calendar days, the repair must be completed within 7 calendar days of receiving the parts.

### 1. Rated Capacity Indicator/Limiter

Temporary alternative measures if inoperative or malfunctioning:

The qualified person directing the lift shall establish procedures for determining load weights and shall make sure that the weight of the load does not exceed the crane's rating at the radius where the load is handled.

The weight of the load must be provided to the operator before the lift is made.

### 2. Boom Angle or Radius Indicator

Temporary alternative measures if inoperative or malfunctioning:

- a. Refer to the pendulum boom angle indicator on the boom butt (visible from operator cab).
- b. Measure the boom angle with a protractor-level on the centerline of boom.
- c. Measure radius using a tape measure.

### 3. Jib Angle or Radius Indicator

Temporary alternative measures if inoperative or malfunctioning. Use either or both:

- a. First, make sure you know the boom angle (see item [2](#) above).
- b. Then, measure radius using a tape measure.

### 4. Drum Rotation Indicator

Temporary alternative measures if inoperative or malfunctioning:

Mark the drum to indicate its rotation.

If the operator cannot see the drum, add mirrors or remote video cameras and displays so the operator can see the mark.

### 5. OPTIONAL Swing Limiter or Proximity Device

Temporary alternative measures if inoperative or malfunctioning:

The qualified person directing the lift shall establish procedures to furnish equivalent protection (for example, assign an additional signal person to observe the distance between the boom or load and job site obstructions to include power lines or to limit the swing sector specified in the Capacity Chart).



## 6. OPTIONAL Drum Spooling Limiter (maximum or minimum bail limit)

Temporary alternative measures if inoperative or malfunctioning:

The qualified person directing the lift, the operator, or a designated signal person shall watch the drum and signal the operator to stop it before it is over spooled (rope does not jump off drum) or before there are less than 3 full wraps of wire rope on the load drum or boom hoist.

## 7. OPTIONAL Closed-Circuit Television (CCTV)

Temporary alternative measures if inoperative or malfunctioning:

A designated signal person shall watch the load, the drums, and the counterweight and provide necessary hand or voice signals to the crane operator.

## ASSEMBLING, DISASSEMBLING, OR OPERATING CRANE NEAR ELECTRIC POWER AND TRANSMISSION LINES

### Electrocution Hazard

Thoroughly read, understand, and abide by all applicable federal, state, and local regulations regarding operation of cranes near electric power lines or equipment.

***United States federal law prohibits the use of cranes closer than 6 m (20 ft) to power sources up to 350 kV and greater distances for higher voltages unless the line's voltage is known [29CFR1910.180 and 29CFR1926.1400].***

***To avoid death or serious injury, Manitowoc recommends that all parts of the crane, boom, and load be kept at least 6 m (20 ft) away from all electrical power lines and equipment less than 350 kV.***

**NOTE** For detailed guidelines on operating near power lines, refer to the current edition of OSHA 29CFR1926.1400 and ASME B30.5 American National Standard.



### WARNING

#### Electrocution Hazard!

Manitowoc cranes are not equipped with all features required to operate within OSHA 29CFR1926.1408, Table A clearances when the power lines are energized.

1. Keep all personnel and their personal belongings (clothing, water coolers, lunch boxes, etc.) away from

the crane if it is being operated near electrical power lines or equipment.

2. Before operating the crane in the vicinity of electrical power lines or equipment, notify the power utility company. Obtain positive and absolute assurance that the power has been turned off.

The crane is NOT INSULATED. Always consider all parts of the load and the crane as conductors, including the wire rope, pendants or straps, and taglines.

Most overhead power lines ARE NOT insulated. Treat all overhead power lines as being energized unless you have reliable information to the contrary from the utility company or owner.

The rules in this section must be followed at all times, even if the electrical power lines or equipment have been de-energized.

3. Crane operation is dangerous when close to an energized electrical power source. Exercise extreme caution and prudent judgment. Operate slowly and cautiously when in the vicinity of power lines.
4. If the load, wire rope, boom, or any portion of the crane contacts or comes too close to an electrical power source, everyone in, on, and around the crane can be seriously injured or killed.

The safest way to avoid electrocution is to stay away from electrical power lines and electrical power sources.

5. The operator is responsible for alerting all personnel to the dangers associated with electrical power lines and equipment. The crane is not insulated. Do not allow unnecessary personnel in the vicinity of the crane while operating. Permit no one to lean against or touch the crane. Permit no one, including riggers and load handlers, to hold the load, load lines, taglines, or rigging gear.
6. Even if the crane operator is not affected by an electrical contact, others in the area may become seriously injured or killed.
7. It is not always necessary to contact a power line or power source to become electrocuted. Electricity, depending on magnitude, can arc or jump to any part of the load, load line, or crane boom if it comes too close to an electrical power source. Low voltages can also be dangerous.

### Set-Up and Operation

1. During crane use, assume that every line is energized ("hot" or "live") and take necessary precautions.
2. Position the crane such that the load, boom, or any part of the crane and its attachments cannot be moved to within 6 m (20 ft) of electrical power lines or equipment.

This includes the crane boom and all attachments. Overhead lines tend to blow in the wind, so allow for movement of the overhead lines when determining a safe operating distance.

3. Erect a suitable barricade to physically restrain the crane, all attachments, and the load from entering into an unsafe distance from electrical power lines or equipment.
4. Plan ahead and always plan a safe route before traveling under power lines. A wooden clearance frame should be constructed to ensure sufficient clearance is maintained between crane and power lines.
5. Appoint a reliable and qualified signal person, equipped with a loud signal whistle or horn and voice communication equipment, to warn the operator when any part of the crane or load moves near a power source. This person should have no other duties while the crane is working.
6. Taglines should always be made of non-conductive materials. Any tagline that is wet or dirty can conduct electricity.
7. DO NOT store materials under power lines or close to electrical power sources.
8. When operating near transmitter/communication towers where an electrical charge can be induced into the crane or load:
  - The transmitter must be deenergized OR,
  - Tests must be made to determine if an electrical charge will be induced into the crane or load.
  - The crane must be provided an electrical ground.
  - If taglines are used, they must be non-conductive.
  - Every precaution must be taken to dissipate induced voltages. Consult with a qualified RF (radio frequency) Consultant. Also refer to local, state, and federal codes and regulations.

## Electrical Contact

If the crane comes in contact with an energized power source, the operator shall:

1. Stay in the crane cab. DON'T PANIC.
2. Immediately warn PERSONNEL in the vicinity to STAY AWAY.
3. Attempt to move the crane away from the contacted power source using the crane's controls which are likely to remain functional.
4. Stay in the crane until the power company has been contacted and the power source has been de-energized.

NO ONE shall attempt to come close to the crane or load until the power has been turned off.

Only as a last resort should an operator attempt to leave the crane upon contacting a power source. If it is absolutely necessary to leave the cab, JUMP COMPLETELY CLEAR OF CRANE. DO NOT STEP OFF. Hop away with both feet together. DO NOT walk or run.

5. Following any contact with an energized electrical source, your Manitowoc dealer shall be immediately advised of the incident and consulted on necessary inspections and repairs.

If the dealer is not immediately available, contact Manitowoc Product Support. The crane must not be returned to service until it is thoroughly inspected for any evidence of damage and all damaged parts are repaired or replaced as authorized by Manitowoc or your Manitowoc dealer.

## REFUELING

1. When using a portable container to refuel the crane, the container must be a safety-type can equipped with an automatic closing cap and a flame arrester.
2. The engine must be **stopped** before refueling the crane.
3. Smoking and open flames must be prohibited in refueling area.

## FIRE EXTINGUISHERS

1. A portable fire extinguisher with a minimum rating of 10 BC must be installed in operator's or machinery cab of the crane.
2. The operator and all maintenance personnel shall be thoroughly familiar with the location, use, and care of the fire extinguisher(s) provided.

## ACCIDENTS

If this crane becomes involved in a property damage and/or personal injury accident, immediately contact your Manitowoc dealer or the Product Safety and Reliability Department at the following address:

**Manitowoc Cranes**  
2401 So. 30th St.  
Manitowoc, WI 54220

Phone: 920-684-6621

Provide a complete description of the accident, including the crane model and serial number. Accident reporting forms can be found at [www.manitowoc.com](http://www.manitowoc.com).

The crane must not be returned to service until it is thoroughly inspected for any evidence of damage. All

damaged parts must be repaired or replaced as authorized by Manitowoc.

## SAFE MAINTENANCE



### WARNING

Importance of safe maintenance cannot be over emphasized. Carelessness and neglect on part of maintenance personnel can result in their death or injury and costly damage to the crane or property.

Safety information in this publication is intended only as a guide to assist qualified maintenance personnel in safe maintenance. Manitowoc cannot foresee all hazards that will arise in field; therefore, **safety remains responsibility of maintenance personnel and crane owner.**

## Maintenance Instructions

To ensure safe and proper operation of Manitowoc cranes, they must be maintained according to the instructions contained in this manual and in the Service Manual provided with the crane.

Crane maintenance and repair must be performed by qualified personnel. These personnel shall **read Operator Manual and Service Manual before attempting any maintenance procedure.** If there is any question regarding maintenance procedures or specifications, contact your Manitowoc dealer for assistance.

**Qualified person** is defined as one who by reason of training and experience is thoroughly familiar with the crane's operation and required maintenance as well as the hazards involved in performing these tasks.

**Training and qualification of maintenance and repair personnel are crane owner's responsibility.**

## Safe Maintenance Practices

1. Perform the following steps (as applicable) before starting a maintenance procedure:
  - a. Park the crane where it will not interfere with other equipment or operations.
  - b. Lower all loads to the ground or otherwise secure them against movement.
  - c. Lower the boom onto blocking at ground level, if possible, or otherwise secure the boom against dropping.
  - d. Move all controls to off and secure all functions against movement by applying or engaging all brakes, pawls, or other locking devices.

- e. Stop the engine and render the starting means inoperative.
- f. Place a warning sign at the start controls alerting other personnel that the crane is being serviced and the engine must not be started. **Do not remove sign until it is safe to return the crane to service.**

2. Do not attempt to maintain or repair any part of the crane while the engine is running, unless absolutely necessary.

If the engine must be run, keep your clothing and all parts of your body away from moving parts. **Maintain constant verbal communication between person at controls and person performing maintenance or repair procedure.**

3. Wear clothing that is relatively tight and belted.
4. Wear appropriate eye protection and approved hard hat.
5. Never climb onto or off a moving crane. **Climb onto and off the crane only when it is parked and only with operator's permission.**

Use both hands and handrails, steps and ladders provided to climb onto and off the crane.

Lift tools and other equipment which cannot be carried in pockets or tool belts onto and off the crane with hand lines or hoists.

6. The boom and gantry are not intended as ladders. Do not attempt to climb lattice work of the boom or gantry to get to maintenance points. If the boom or gantry is not equipped with an approved ladder, lower them before performing maintenance or repair procedures.
7. Do not remove cylinders until the working unit has been securely restrained against movement.
8. Pinch points are impossible to eliminate; watch for them closely.
9. Pressurized air, coolant, and hydraulic oil can cause serious injury. Make sure all air, coolant, and hydraulic lines, fittings, and components are tight and serviceable.

### Do not use your hands to check for air, coolant or hydraulic oil leaks:

- Use a soap and water solution to check for air leaks (apply to fittings and lines and watch for bubbles).
  - Use a piece of cardboard or wood to check for coolant and hydraulic oil leaks.
10. Relieve pressure before disconnecting air, coolant, and hydraulic lines and fittings.
  11. Do not remove the radiator cap while the coolant is hot or under pressure. Stop the engine, wait until the pressure drops and the coolant cools, then slowly remove the cap.

12. Avoid battery explosion: do not smoke while performing battery maintenance or short across battery terminals to check its charge.
13. Read the safety information in the battery manufacturer's instructions before attempting to charge a battery.
14. Avoid battery acid contact with skin and eyes. If contact occurs, flush the area with water and immediately consult a doctor.
15. Stop the engine before refueling the crane.
16. Do not smoke or allow open flames in refueling area.
17. Use a safety-type can with an automatic closing cap and flame arrestor for refueling.
18. Hydraulic oil can also be flammable. Do not smoke or allow open flames in the area when filling hydraulic tanks.
19. Never handle wire rope with bare hands. Always wear heavy-duty gloves to prevent being cut by broken wires.
20. Use extreme care when handling coiled pendants. Stored energy can cause the coiled pendants to uncoil quickly with considerable force.
21. When inflating tires, use a tire cage, a clip-on inflater, and an extension hose which permits standing well away from the tire.
22. Only use cleaning solvents which are non-volatile and non-flammable.
23. Do not attempt to lift heavy components by hand. Use a hoist, jacks, or blocking to lift components.
24. Use care while welding or burning on the crane. Cover all hoses and components with non-flammable shields or blankets to prevent a fire or other damage.
25. To prevent damage to crane parts (bearings, cylinders, swivels, slewing ring, computers, etc.), perform the following steps **before welding on the crane**:
  - Disconnect all cables from batteries.
  - Disconnect output cables at engine junction box.
  - Attach the ground cable from the welder directly to the part being welded and as close to the weld as possible.

Do not weld on the engine or engine mounted parts (per engine manufacturer).
26. Disconnect and lock the power supply switch before attempting to service high voltage electrical components and before entering tight areas (such as carbody openings) containing high voltage components.
27. When assembling and disassembling booms, jibs, or masts on the ground (with or without support of boom rigging pendants or straps), securely block each section to provide adequate support and alignment.
 

**Do not go under boom, jib, or mast sections while connecting bolts or pins are being removed.**
28. Unless authorized in writing by Manitowoc, do not alter the crane in any way that affects the crane's performance (including welding, cutting, or burning of structural members or changing pressures and flows of air/hydraulic components). Doing so will invalidate all warranties and Capacity Charts and make the crane owner/user liable for any resultant accidents.
29. **Keep crane clean.** Accumulations of dirt, grease, oil, rags, paper, and other waste will not only interfere with safe operation and maintenance but also create a fire hazard.
30. Store tools, oil cans, spare parts, and other necessary equipment in tool boxes. Do not allow these items to lie around loose in the operator cab or on walkways and stairs.
31. Do not store flammable materials on the crane.
32. Do not return the crane to service at completion of maintenance or repair procedures until all guards and covers have been reinstalled, trapped air has been bled from hydraulic systems, safety devices have been reactivated, and all maintenance equipment has been removed.
33. Perform a function check to ensure proper operation at the completion of maintenance or repair.

## ENVIRONMENTAL PROTECTION

**Dispose of waste properly!** Improperly disposing of waste can threaten the environment.

Potentially harmful waste used in Manitowoc cranes includes — but is not limited to — oil, fuel, grease, coolant, air conditioning refrigerant, filters, batteries, and cloths which have come into contact with these environmentally harmful substances.

Handle and dispose of waste according to local, state, and federal environmental regulations.

When filling and draining crane components: do not pour waste fluids onto the ground, down any drain, or into any source of water.

- Always drain waste fluids into leak proof containers that are clearly marked with what they contain.
- Always fill or add fluids with a funnel or a filling pump.
- Immediately wipe up any spills.



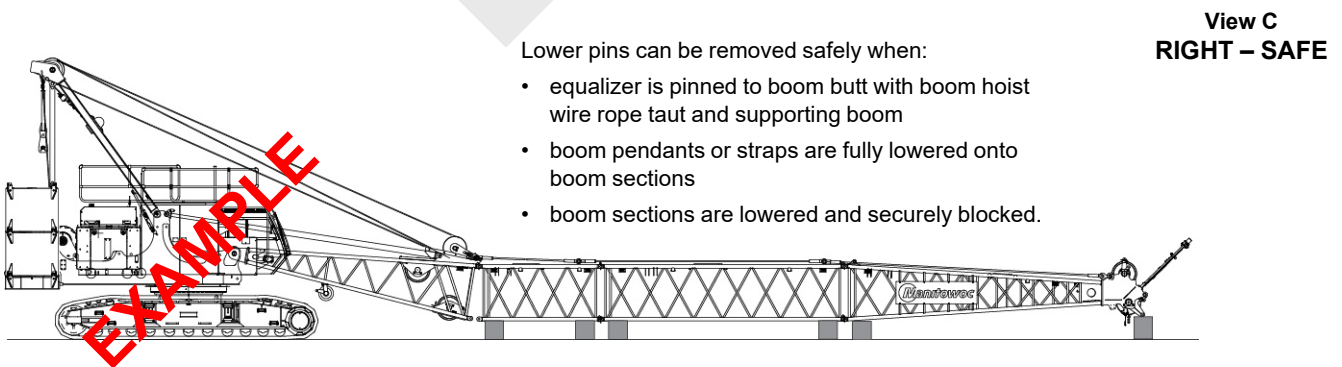
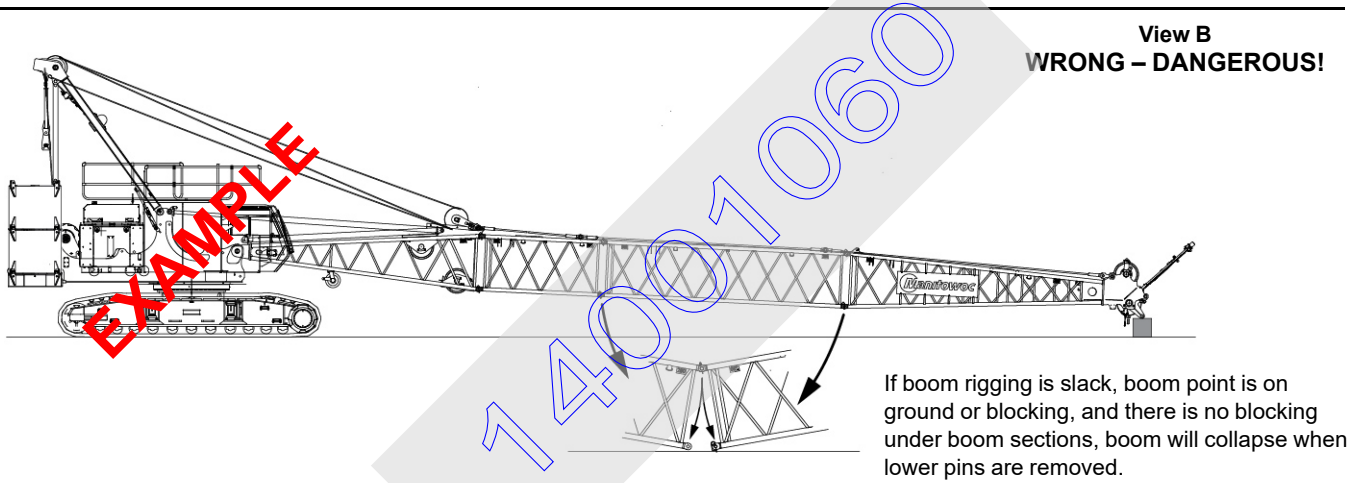
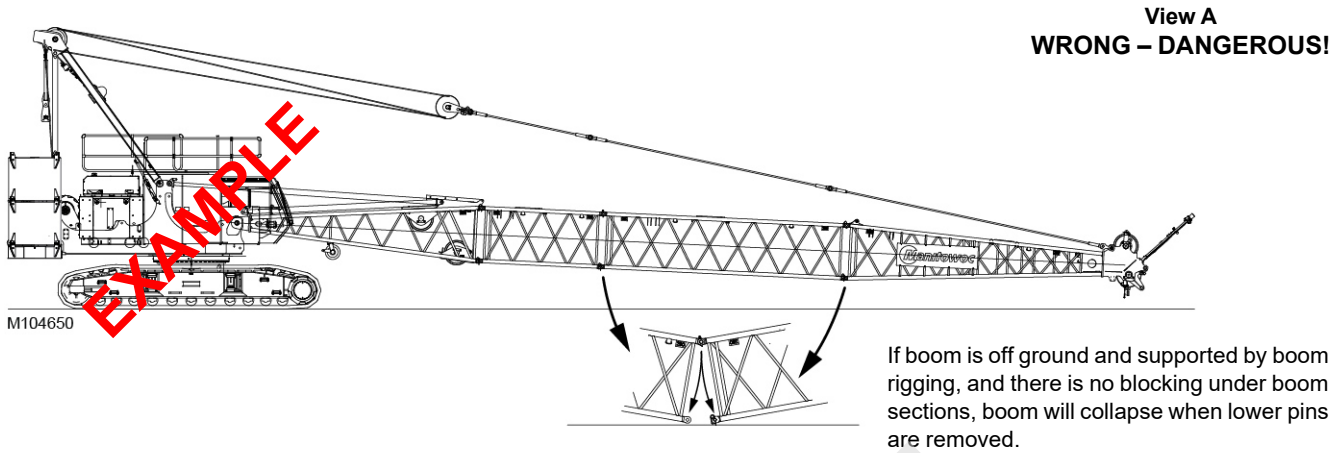


Figure 2-4. Boom Disassembly

## BOOM DISASSEMBLY SAFETY

**NOTE** The term “boom” used in the following instructions applies to all lattice attachments (fixed jib, luffing jib, mast, etc.).



**DANGER!**

### Collapsing Boom Hazard!

Prevent death or serious injury when disassembling boom sections — read and adhere to the following instructions.

Safe handling of lattice booms during disassembly is a primary concern for preventing serious or fatal injuries. A boom can collapse during disassembly if workers fail to observe safe working practices.

Accidents during boom disassembly usually result from one of three primary causes:

- Workers are not familiar with equipment or are not properly trained.
- Disassembly area is not suitable.
- Safe procedures are overlooked because not enough time is allocated for the task.

### General

Safety decals ([Figure 2-5](#)) are placed near the connectors of the boom sections as shown on the Boom Disassembly Decal Drawing at the end of this section.

Workers involved with boom disassembly shall be trained and experienced in the operation and disassembly of construction cranes. Everyone shall read and understand these instructions, the information in the Boom Assembly Drawing, and the instructions in Section 4 before beginning disassembly. Anyone who has a question should ask for an explanation. **One worker who does not fully understand or fails to follow correct procedures can endanger other workers.**

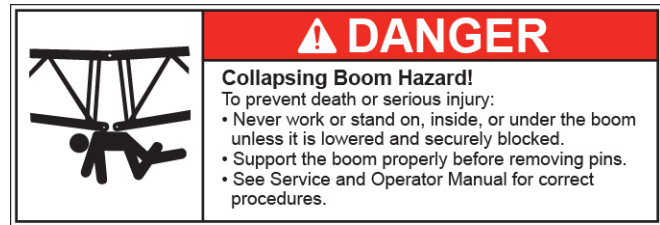
### Location

Select a suitable location for boom disassembly. It must be firm, level, and free of obstructions. It should have enough open space to accommodate the crane, the length of boom, and – if required – movement of an assist crane or other equipment. If possible, secure the area to keep unauthorized personnel and vehicles away.

### Pin Removal

When removing pins from boom sections, stand clear of pins being removed. Even though the boom is resting on

blocking, individual pin connections may still be under load. Pins can be ejected forcefully if the boom has any pressure on it or if the boom is not supported properly.



M101904

Figure 2-5. Safety Decal

## Disassembly Precaution

Always block boom sections so they are securely supported and cannot shift or move suddenly when pins are removed. If there is any doubt about a boom disassembly procedure, **block tightly under boom sections before removing any pin.**



**DANGER**

### Collapsing Boom Hazard!

Boom can collapse or jerk when pins are removed. To avoid death or serious injury:

- Do not remove bottom connecting pins from any boom section when boom is supported by pendants as shown in [Figure 2-4](#), View A.
- Do not remove pendant connecting pins until pendants are fully lowered onto boom sections as shown in [Figure 2-4](#), View C.
- Do not remove bottom connecting pins from any boom section when boom point is resting on ground or blocking and boom rigging is slack as shown in [Figure 2-4](#), View B.
- Never work or stand inside boom unless it is lowered and securely blocked as shown in [Figure 2-4](#), View C.
- Do not stand or walk on top of the boom.



**DANGER**

### Falling Boom Hazard!

Crane can tip or the boom can collapse if excess boom is cantilevered. Never cantilever more boom than allowed in rigging drawing or capacity chart.

## SPECIAL APPLICATION/SERVICE

Special Application/Service is defined as anything other than normal lifting activities or normal lifting operation.

As identified in ASME B30.5, cranes are sometimes used for service other than lifting service and/or special lifting operations. In such cases Manitowoc or a qualified person shall review the service to be performed and jobsite conditions prior to operation. If appropriate, Manitowoc or a qualified person shall determine and establish a reduction in rated capacity, operating limitations, maintenance, testing and inspection requirements based on the job site conditions/limitations.

Because Manitowoc is not aware of all job site conditions/limitations we cannot provide further guidance until the intended service is understood, and a review of the conditions/limitations is complete.

Manitowoc cannot foresee all hazards that will arise in the field related to the special applications/services below; therefore, safety remains the responsibility of the qualified lifting personnel involved in the crane operations and owners.

Additional resources, training and experience may exist in the crane industry to provide guidance of risk assessments and hazard avoidance regarding special applications/service.

## PERSONNEL HANDLING POLICY

In 1998, the American Society of Mechanical Engineers issued a new American National Standard entitled, Personnel Lifting Systems, ASME B30.23-1998. This standard provides, ***“lifting and lowering of personnel using ASME B30 Standard hoisting equipment shall be undertaken only in circumstances when it is not possible to accomplish the task by less hazardous means. Unless all of the applicable requirements of this volume are met, the lifting or lowering of personnel using ASME B30 Standard equipment is prohibited.”***

The ASME Standards recognize that mobile and locomotive cranes are primarily designed and intended for handling materials and not personnel. The ASME Standards have a retrofit statement that applies to existing cranes after the standards go into effect. It is not the intent of the standards to require retrofitting of existing equipment. If an item is being modified, the performance requirement must be reviewed relative to the current standard.

This new standard is consistent with the U.S. Department of Labor, Occupational Safety and Health Administration (OSHA) regulations for Construction that state, in 29CFR1926.1431(a): ***The use of a crane or derrick to hoist employees on a personnel platform is prohibited, except when the erection, use, and dismantling of conventional means of reaching the work site, such as a***

***personnel hoist, ladder, aerial lift, elevating work platform or scaffold, would be more hazardous or is not possible because of structural design or work site conditions.***

Use of a Manitowoc crane to handle personnel is acceptable provided:

- The crane user shall comply with the manufacturer's specifications and limitations for lifting accessories (hooks, slings, personnel platforms, etc.).
- The requirements of the applicable national, state and local regulations and safety codes are met.
- A determination has been made that use of a crane to handle personnel is the least hazardous means to perform the work.
- The crane operator shall be qualified to operate the specific type of hoisting equipment used in the personnel lift.
- The crane operator shall remain in the crane cab at all times when personnel are off the ground.
- The crane operator and occupants have been instructed in the recognized hazards of personnel platform lifts.
  - The crane is in proper working order.
  - Load and boom hoist drum brakes, swing brakes, and locking devices such as pawls and dogs must be engaged when the occupied personnel platform is in a stationary position.
- The crane must be equipped with a boom angle indicator that is visible to the crane operator.
- The crane must be equipped with boom hoist limiting device.
- If the luffing jib is used for hoisting personnel, the crane must be equipped with a luffing jib angle indicator that is visible to the crane operator.
- If the luffing jib is used for hoisting personnel, the crane must be equipped with a luffing hoist limiting device.
- The crane is equipped with a positive acting device which prevents contact between the load block or overhaul ball and the boom tip (anti-two-block device).
 

For friction cranes, this implies the addition of spring applied brakes activated by the anti-two-block device. The load line hoist drum must have a system or device on the power train, other than the load hoist brake, which regulates the lowering rate of speed of the hoist mechanism (controlled load lowering).

***Free fall of the hoist line is prohibited.***
- The Operator Manual is in the cab, readily accessible to the operator.

- The crane's load Capacity Chart is affixed inside the crane cab, readily accessible to the operator. The total weight of the loaded personnel platform and related rigging must not exceed 50 percent of the rated capacity for the radius and configuration of the crane.
- The crane is uniformly level within one percent of level grade and located on a firm footing. Some Capacity Charts require more stringent levelness criteria.  
Cranes with outriggers or stabilizers must have them all extended and locked. All outriggers or stabilizers must be extended equally in accordance with the Capacity Charts and operating procedures.
- Handling personnel from a platform suspended by wire rope from a luffing jib is acceptable, but only when it is not possible to accomplish the task using a less hazardous means. The crane user and operator shall take into account hazards that may be present when using a luffing jib.
- Direct attachment of a personnel platform to a luffing jib is prohibited.
- The platform meets the requirements as prescribed by applicable standards and regulations.
- Applicable personal protection equipment is provided (for example, personal fall-protection system).
- For wire rope suspended platforms, the crane is equipped with a hook latch that can be closed and locked, eliminating the throat opening.
- The platform is properly attached and secure.
- Personnel platforms must not be used in winds exceeding 20 mph (9 m/s) at the hoisted platform height or in electric storms, snow, ice, sleet, or other adverse weather conditions which could affect the safety of personnel.
- Hoisting personnel within 6 m (20 ft) of a power line that is up to 350 kV or within 15 m (50 ft) of a power line that is over 350 kV is PROHIBITED, except for work covered in OSHA 29CFR1926 subpart V.

For operation outside the United States, the requirements of the applicable national, state and local regulations and safety codes must be met. This may include, in addition to the above:

- Automatic brakes such that when the equipment operating controls are released, the motions are brought to rest.
- A holding device (such as a load hold check valve) must be provided in the hydraulic or pneumatic

systems to prevent uncontrolled movement of the hoisting equipment in the case of a system failure.

Manitowoc offers upgrade packages for friction controlled models to install anti-two-block, dead man control, and automatic hoist system control requirements to satisfy other codes and standards.

Manitowoc recommends that cranes be properly maintained, regularly inspected, and repaired as necessary. All safety signs must be in place and legible. We also urge Manitowoc crane owners to upgrade their cranes with rated capacity indicator/limiter systems for all lifting operations.

In 2016, **The International Crane Stakeholder Assembly** published a guidance document titled *Lifting of Persons with Mobile Cranes*. This document may assist crane owners and lifting personnel in the risk assessment of personnel handling.

If you have any questions about this subject or other product safety matters relating to the operation and use of a Manitowoc crane, please contact your Manitowoc dealer or the Product Safety and Reliability Department at the following address:

Manitowoc Cranes  
2401 So. 30th St.  
Manitowoc, WI 54220  
Phone: 920-684-6621

## PEDESTAL/BARGE MOUNTED CRANES



### WARNING

#### Overload Hazard!

A pedestal mounted crane will not tip to indicate to the operator that the crane's capacity has been exceeded. When the capacity of a pedestal mounted crane is exceeded, the hook rollers or other structural components may break, before the load lines fail, causing the crane to separate from the pedestal.

For this reason, great care must be taken to operate a pedestal mounted crane within its rated capacity.

Careful planning is required before a crane can be operated on a barge. The crane user shall verify that the barge is capable of limiting crane list and/or dynamics to the maximum allowable specified in the Capacity Charts. If the specified crane list and/or dynamic conditions are exceeded, the crane's capacity may be exceeded; the hook rollers or other structural components may break, causing the crane to separate from the pedestal.



**! WARNING**

The crane owner/user shall verify that the method used to fasten or restrain the crane to the foundation, the barge, the ship or the floating platform is strong enough, under all operating conditions, to prevent the crane from breaking off the foundation or moving on the barge.

Manitowoc does not permit use of a lattice boom truck crane on a barge, a ship, or a floating platform.

**Pedestal Mounted Crane**

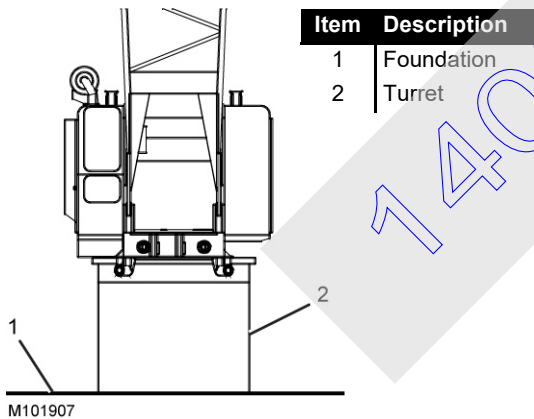
Also see ASME publication B30.8-2015, Floating Cranes and Derricks.

**Definition**

A pedestal mounted crane is a crane which is securely fastened to a foundation, barge, ship, or floating platform so the crane is restrained from tipping.

**Examples**

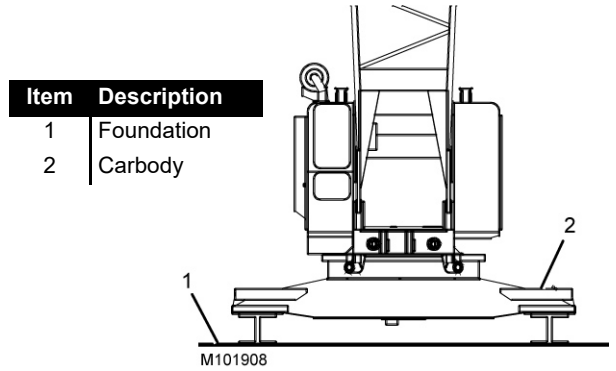
1. Crane rotating bed mounted on a turret (pedestal) which is securely fastened to the foundation (Figure 2-6).



**Figure 2-6. Turret-Mounted Crane**

2. Crane rotating bed mounted on a carbody (crawlers removed) which is securely fastened to the foundation (Figure 2-7).

**NOTE** If the carbody will be bolted to the foundation, contact your Manitowoc dealer for the recommended bolt pattern and for the type and quantity of bolts to be used.



**Figure 2-7. Carbody-Mounted Crane**

**Barge Mounted Crane**

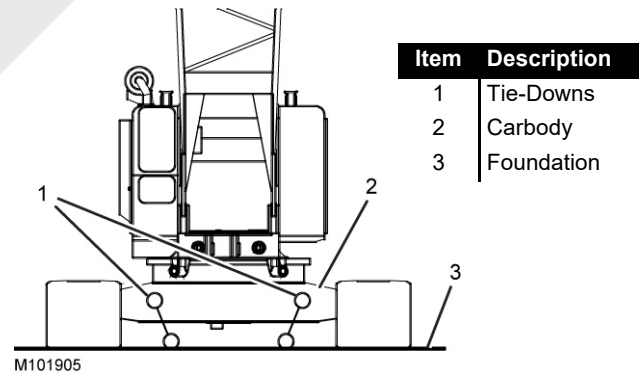
**Definition**

A barge mounted crane is a crane that is anchored or restrained in a work area of the barge, ship, or floating platform and is subjected to tipping forces.

**Examples**

**NOTE** The foundation is the deck of the barge, ship, or floating platform.

1. Crawler-mounted crane with the carbody anchored with tie-downs to the foundation (Figure 2-8).



**Figure 2-8. Crawler-Mounted Crane**

2. Crawler-mounted crane working on a timbered area of the barge, ship, or floating platform with the crawlers restrained by curbing and end stops (Figure 2-9). When not working, the crane carbody is anchored with tie-downs to the foundation. **Traveling with load is not permitted.**

**NOTE** Manitowoc does not permit traveling on a barge deck with load.

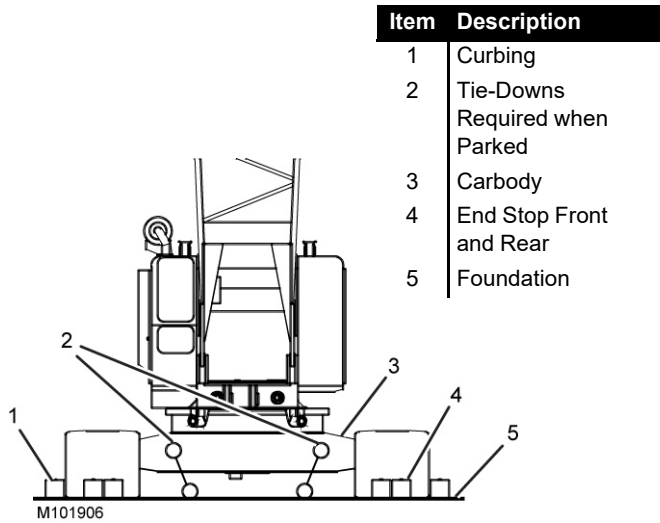


Figure 2-9. Crawler-Mounted Crane

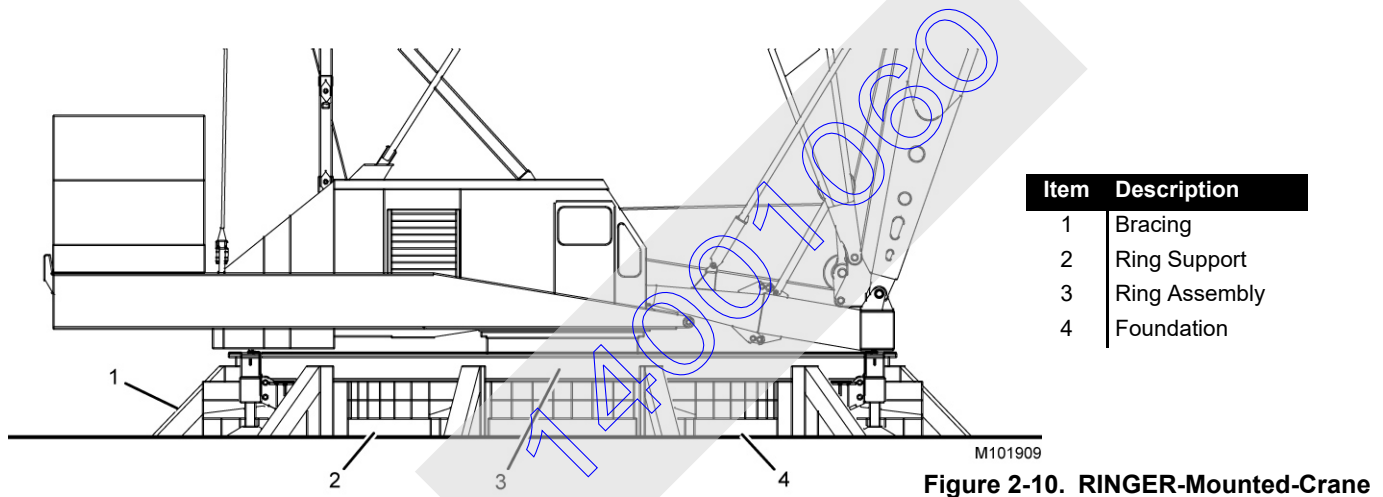
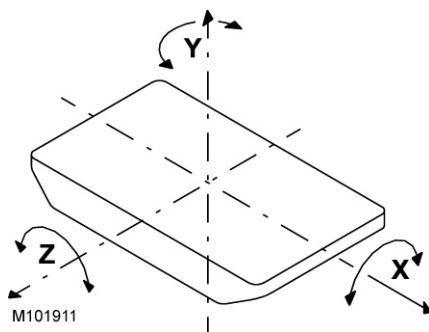


Figure 2-10. RINGER-Mounted-Crane



AXIS		TRANSITIONAL		ROTATIONAL	
SYMBOL	NAME	STATIC	DYNAMIC	STATIC	DYNAMIC
X	Longitudinal		Surge	Heel List	Roll
Y	Vertical		Heave		Yaw
Z	Lateral		Sway	Trim	Pitch

Figure 2-11. Barge Dynamics

3. RINGER® (crawler mounted, carbody mounted) supported on blocking, screw jacks, or steel pedestals which are braced and fastened to the foundation in such a manner as to prevent movement (Figure 2-10).

**NOTE** RINGERS must be equipped with hook rollers on the boom carrier and the counterweight carrier.

4. RINGER (platform mounted) which has the ring braced and fastened directly to the foundation in such a manner as to prevent movement.

### Capacity Charts for Barge Mounted Crane

Manitowoc provides two types of Capacity Charts for a crane mounted on a barge or other supporting structure under static conditions.

1. A Capacity Chart based on tipping when the crane is anchored only to prevent shifting.
2. A Capacity Chart based on structural competence when the crane is securely fastened for use as a pedestal mounted crane.

**NOTE** Unless otherwise specified in a machine list Capacity Chart, a 0 degree machine list Capacity Chart rating applies to machine list **not to exceed 1/2 degree**. All other machine list ratings – 1°, 2°, and 3° – must NOT be exceeded.

### Shock Loading Caused by Barge Dynamics

Shock loads to the crane can be experienced when the barge is subjected to up and down movement of wave action (referred to as DYNAMICS). [Figure 2-11](#) illustrates the dynamic conditions of the barge which influence crane capacity.

### CAUTION

#### Structural Damage Hazard!

If the crane's boom or structure is shock loaded during operation, or there is any indication of shock loading, all structural components of the crane must be inspected to detect cracks and other damage. Nondestructive test equipment, such as magnetic particle or ultrasonic procedures, is recommended for this inspection.

**NOTE** Manitowoc does not recommend crane operation under dynamic conditions.

### Operation on Barge

Machine list and/or dynamics will be experienced when a crane is operated on a barge, ship, or floating platform. Both of these conditions reduce the crane's capacity and each must be taken into account for safe operation on a barge, ship, or floating platform.



### WARNING

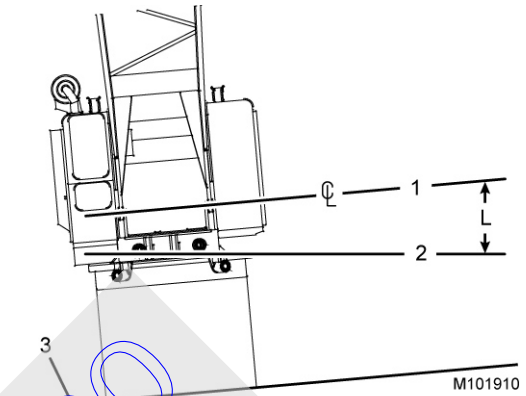
#### Tipping Crane Hazard!

Tie-downs which only prevent the crane from shifting as in barge, ship or floating platform mounting, may not provide adequate support when using a Capacity Chart for pedestal mounting. Before operating a crane on a barge, a ship or a floating platform, the crane user shall verify that correct the Capacity Chart is being used — pedestal mounted, barge mounted, 0°, 1°, 2° or 3° list or dynamic Capacity Chart.

Failing to use the correct Capacity Chart can result in an accident.

### Barge Mount Definitions

1. Machine List, as defined by Manitowoc, is the crane's out-of-level condition — from side-to-side — as measured by the angle between horizontal and a line drawn through the centerline of the crane's boom hinge pins ([Figure 2-12](#)). This out-of-level condition creates side load and affects the crane's lifting capacity.



Item	Description
1	Centerline through Boom Hinge Pins
2	Horizontal
3	Barge Deck
L	Degrees of Machine List (Maximum allowable is specified in Capacity Chart)

**Figure 2-12. Machine List**

2. Barge List (also referred to as heel or trim) causes swing out of the load and may produce side load. When Manitowoc provides a Capacity Chart showing capacities for a 2 degree machine list for example, we are referring to the maximum allowable lifting capacity for the crane when experiencing an out-of-level condition (side-to-side) of 2 degrees as measured by angle between horizontal and a line drawn through centerline of the crane's boom hinge pins.

Unless otherwise specified in the Capacity Chart, barge list (heel or trim) must not exceed the machine list degrees given in the Capacity Chart.

3. Barge List and Machine List are not the same. As the crane rotates on a barge, barge list (as defined above) will change. The worst machine list condition generally occurs when the crane swings over the corner of the barge, producing maximum side load.

### Inspection of Barge-Mounted Crane

To aid in preventing harmful and damaging failure as previously indicated, regular inspection for signs of overloading in the following load bearing components is

required. Correct each defect found before placing the crane into service.

- Boom
- Counterweight
- Backhitch
- Rotating Bed
- Wire Rope
- Pendants and Straps
- Hook and House Rollers

When equipped with hook rollers, it is recommended that each hook roller assembly be inspected daily for any sign of overloading, to include:

- Deformation of roller path
- Proper hook roller adjustment
- Deformation or cracks in hook roller hanger
- Bent hook roller shaft
- Damaged bearings

## Transporting Crane on Barge

If it is necessary to transport the crane on a barge, ship, or floating platform when dynamic conditions will be experienced, the boom must be lowered onto a cradle (or other support) and the crane's boom, rotating bed, and lowerworks must be secured against movement. If the crane is equipped with a mast, the mast must be securely tied down with guylines. Failing to take these steps can result in shock load or side load damage to the boom and mast.

## PILE DRIVING AND EXTRACTING

### Introduction

By operating within the following guidelines, pile driving is an approved application for Manitowoc brand mobile crawler cranes. Because pile driving and extracting presents many variables and unknowns, Manitowoc crane owners shall exercise discretion when considering the use of a crane for this application.

It is not our intention to recommend specific types or makes of pile driving and extracting equipment but rather to advise crane owners of our operational requirements to help avoid pile driving and extracting from having any detrimental effect on the crane and invalidating the new machine warranty. The following are the operating requirements that must be used during pile driving and extracting with a Manitowoc crawler crane. These notes are in addition to any guidelines published on the crane's capacity charts.

## Operation of Pile Driving and Extracting Equipment

1. The combined weight of the drive or extractor, piling, leads, attachments, etc., must not exceed the published load chart values. A qualified person shall determine if additional capacity reductions are necessary.
2. The pile driver or pile extractor must be kept clear of the boom top at all times.
3. The crane operator shall ensure that the crane is not subject to impact loading or vibration being induced into the boom and crane structure by meeting the rate of descent of the driver and piling.
4. Pile driving or extracting must be restricted to the boom. A qualified person shall determine an appropriate configuration.
5. Pile Extraction is only permitted when using extraction devices that do not transmit vibration or shock loading into the crane. All possible precautionary measures must be taken to prevent shock loads or vibration from being imposed on crane components, either directly through the hoist cable or indirectly from ground borne vibration. Do not exceed load capacity.
6. The crane operator and other personnel associated with the pile driving and pile extraction operation shall have read and understood all safety standards applicable to crane operations as well as being thoroughly trained in the safe operation of pile driving and extracting equipment.
7. The load lines must be kept vertical at all times during pile driving and pile extraction operations.

## Crane Equipment

1. Manitowoc recommends that hoist cable length be reduced to operate on the first layer for optimal spooling.
2. Crane must be assembled per applicable rigging drawing and operator manual.
3. All hoist hooks must be equipped with a positive locking latch.
4. Refer to the specific hook block or headache ball manufacturer website for additional guidelines on usage in pile driving applications.

## Crane Inspection

1. In addition to the crane's frequent and periodic inspections, dated daily records must be maintained showing inspections were performed on the crane during the time it was used for pile driving or extraction.
2. The "40 Hours of Operation or Weekly" boom related inspection intervals published in the crane's *Inspection*

*and Maintenance Checklist* must be increased to 8 hour or daily intervals for the duration of pile driving operations.

3. The hoist cable must be inspected daily to ensure no abrasion or wear is occurring.

In 2014, **FEM**, a member of **The International Crane Stakeholder Assembly** published a guidance document titled *Using Mobile Cranes for Pile Driving/Extraction*. Additionally, ASSE A 10.19 Safety Requirements for Pile Installation and Extraction Operations may assist crane owners and lifting personnel in the risk assessment related to pile driving/extraction.

## ELECTROCUTION HAZARD DEVICES

The use of insulated links, insulated boom cages/guards, or proximity warning devices does not assure that electrical contact will not occur. Therefore, Manitowoc does not endorse their use. When insulated links, insulated boom cages/guards, or proximity warning devices are installed on the crane as required by Regulations, Industry Codes, or company policies, the crane owner is responsible for ensuring that:

- a. The device manufacturer is contacted and provides instructions for storage, inspection, maintenance, and use of the devices.
- b. The device manufacturer provides all limitations and restrictions of the device.
- c. The documentation provided by the device manufacturer is maintained on the crane and available to the crane operator at all times.

Further, when insulated links, insulated boom cages/guards, or proximity warning devices are installed on the crane, a pre-operational meeting is to be held and a review of the instructions, limitations and restrictions related to the device(s) will be communicated to all personnel that are to work on or around the crane.

Even if the crane is equipped with these devices, failure to follow the rules, limitations and precautions outlined in this manual and provided by the device manufacturer at all times may result in serious injury or death.

**Do not depend on grounding.** Grounding of a crane affords little or no protection from electrical hazards. The effectiveness of grounding is limited by the size of the conductor (wire) used, the condition of the ground, the magnitude of the voltage/current present, and numerous other factors.

## MULTIPLE LOAD LINE OPERATION

Multiple load line operation is becoming common practice for applications like panel tilt-up, pile tilt-up, pile driving, rolling fabricated sections, etc. The multiple load lines may be on a

common shaft (each with different parts of line) or on multiple shafts (lower boom point and upper point, boom point and fixed jib point, etc).

Manitowoc authorizes multiple load line operation for those applications requiring it, provided the following steps are performed:

1. The qualified lift planner and crane operator shall read and become thoroughly familiar with the appropriate Capacity Charts and Wire Rope Specification Charts.
2. The lift planner and the crane operator shall make sure the total load does not exceed the rated capacity given in the Capacity Chart and Wire Rope Specification Chart for given boom point or jib point, whichever is less.

EXAMPLE: If one load line is lifting from the jib point, the proper jib chart applies.

3. The crane must be thoroughly inspected by a qualified person prior to setup.
4. The crane must be thoroughly inspected for load line interference caused by routing and reeving of multiple load lines. If interference is found, it must be eliminated.
5. For cranes produced before 2003, Rated Capacity Indicators/Limiters were not required by ASME B30.5 for non-personnel lifting.

To aid the operator in staying within the crane's Capacity Chart with the total applied load, Manitowoc recommends that its cranes be equipped with Rated Capacity Indicators/Limiters to monitor the load on each load line.

**Operator is still responsible for knowing load and radius whether or not the crane is equipped with load indicator(s).**

6. Manitowoc recommends that each load line be equipped with an anti two-block device.
7. Manitowoc's Capacity Charts are based on freely suspended loads. To prevent side load damage to the boom, jib, and sheaves:
  - The load lines must hang as close to vertical as possible to minimize side and forward loads.
  - The load must remain centered on the boom and jib point shafts unless special lift approval is granted by Manitowoc.
  - The load lines should be located over the load's center of gravity as it is supported on a trailer, a barge, or the ground.
8. To minimize the angle of the load transmitted into the boom and/or jib, the distance between the load points and the hook points must be a minimum of three times the horizontal distance between the hook point on the load being lifted.



9. The crane operator shall be familiar with the operational characteristic of the crane as it relates to multiple drum operation (simultaneous operation, same or opposite direction, or individual operation).
10. When using tandem drums, the maximum operating layers may be limited depending on whether the crane was initially designed for tandem drum operation or not.
11. Load shift when lifting with two hooks may be more unpredictable than typical one hook lifting.

## MULTIPLE CRANE LIFTS

Operate with extreme caution when using more than one crane to lift the same load. Any lift that requires more than one crane to lift the same load must be precisely planned and coordinated by a qualified person due to new and different hazards.

The following additional precautions must be taken if it is necessary for more than one crane to lift the load:

- a. Secure the services of a qualified person to analyze and plan the lift.
  - b. Verify proper controls are in place to prevent overload such as the necessity to reduce crane ratings, load position, boom position, ground support, and speed of movements. These controls must be in accordance with the qualified person's decision and all other requirements identified in the operator manual.
- c. Ensure the lift director coordinates and instructs all personnel involved in the lift plan, to include but limited to, proper rigging and positioning of the load and all movements to be made prior to beginning the lift.
  - d. Make sure all signals are coordinated through the lift director.
  - e. A qualified person must direct the lift.
  - f. Maintain communication between all parties throughout the entire lift. If possible, provide approved radio equipment for voice communication between all parties engaged in the lift.
  - g. Ensure the load lines are directly over the attach points to avoid side loading, forward loading, and transfer of loading from one crane to the other.

In 2016, **The International Crane Stakeholder Assembly** published a guidance document titled *Lifting A Load With Several Mobile Cranes (Multiple Crane or Tandem Lifting)*. This document may assist crane owners and lifting personnel in the risk assessment of multiple crane lifts.

# SECTION 3

## OPERATING CONTROLS AND PROCEDURES

### TABLE OF CONTENTS

Standard Hand Signals for Controlling Crane Operations . . . . .	3-2
Symbol Identification . . . . .	3-4
Cab Window Operation . . . . .	3-10
Opening Windows for Ventilation. . . . .	3-10
Past Production Cab . . . . .	3-10
Current Production Cab . . . . .	3-10
Exiting Cab in Emergency . . . . .	3-10
Past Production Cab Only . . . . .	3-10
Current Production Cab Only . . . . .	3-10
Operating Controls . . . . .	3-10
General . . . . .	3-10
Controls Identification and Function . . . . .	3-14
A – Engine Controls. . . . .	3-14
A1. Engine Ignition Switch . . . . .	3-14
A2. Engine Emergency Stop Switch . . . . .	3-14
A3. Engine Hand Throttle . . . . .	3-14
A4. Engine Foot Throttle . . . . .	3-14
A5. Engine Clutch Lever . . . . .	3-14
A6. Battery Disconnect Switch . . . . .	3-15
A7. DPF Switch . . . . .	3-15
B – Accessory Controls . . . . .	3-18
B1. Overhead Windshield Wiper Switch . . . . .	3-18
B2. Front Windshield Wiper-Washer Switch . . . . .	3-18
B3. Climate Control Panel . . . . .	3-18
B4. Crane Work Lights Switch . . . . .	3-18
B5. Panel Light Switch . . . . .	3-18
B6. Boom Pins Switch . . . . .	3-19
B8. Dome Light Switch . . . . .	3-19
B9. Overhead Fan Switch . . . . .	3-19
B10. Horn Switch . . . . .	3-19
B11. Cab Tilt Switch . . . . .	3-19
B12a. Cigarette Lighter Receptacle . . . . .	3-19
B12b. Power Supply Receptacle . . . . .	3-19
B13. Programmable Receptacle . . . . .	3-19
B14. Fire Extinguisher . . . . .	3-19
B15. Radio/CD Player (optional) . . . . .	3-19
B16. Overhead Sun Shade and Tinted Visor . . . . .	3-19
B17. Machinery Heaters . . . . .	3-19
C – Indicators. . . . .	3-21
C1. Fuel Level . . . . .	3-21
C2. Engine Coolant Temperature . . . . .	3-21
C3. Engine Oil Pressure . . . . .	3-21
C4. Battery Voltage . . . . .	3-21
C5. Drum Rotation Indicators . . . . .	3-21
C6. Rear View Mirrors . . . . .	3-21
C7. Boom Angle Indicator . . . . .	3-21
C8. Cab Beacon (optional) . . . . .	3-21
C9. Upperworks Level . . . . .	3-21
C10. Wind Speed Transmitter . . . . .	3-22
D – Special Controls . . . . .	3-22
D1. Rated Capacity Indicator/Limiter Display and Indicator Lights . . . . .	3-22

D2. Main Display . . . . .	3-22
D3. Display Touch Pad Controls . . . . .	3-22
D4. Limit Bypass Switch . . . . .	3-22
D5. Luffing Jib Limit Bypass Switch . . . . .	3-22
D6. Seat Switch . . . . .	3-22
E – Boom Hoist Controls . . . . .	3-26
E1. Drum 4 (Boom Hoist) Park Switch . . . . .	3-26
E2. Drum 4 (Boom Hoist) Handle . . . . .	3-26
F – Load Drum Controls . . . . .	3-27
F1. Drum 1 (Front Drum) Park Switch . . . . .	3-27
F2. Drum 2 (Rear Drum) Park Switch . . . . .	3-27
F3. Drum 3 (Auxiliary/Luffing Jib) Park Switch . . . . .	3-27
F4. Drum 1 (Front Drum) Handle . . . . .	3-27
F5. Drum 2 (Rear Drum) Handle . . . . .	3-27
F6. Drum 3/4 (Auxiliary/Luffing Jib) Handle . . . . .	3-27
F7. Drum 1 (Front Drum) Working Brake Pedal . . . . .	3-27
F8. Drum 2 (Rear Drum) Working Brake Pedal . . . . .	3-27
G – Swing Controls . . . . .	3-28
G1. Swing Park Switch . . . . .	3-28
G2. Swing Handle . . . . .	3-28
G3. Swing Holding Brake Switch . . . . .	3-28
H – Travel Controls . . . . .	3-29
H1. Travel Park Switch . . . . .	3-29
H2. Travel Speed Selector . . . . .	3-29
H3. Travel Cruise Selector . . . . .	3-29
H4. Left Crawler Handle or Pedal . . . . .	3-30
H5. Right Crawler Handle or Pedal . . . . .	3-30
Limit Devices . . . . .	3-30
1. Boom Maximum Up Limit . . . . .	3-30
2. Boom Down Limit . . . . .	3-30
3. Block-Up Limit . . . . .	3-30
4. Luffing Jib Up Limit . . . . .	3-31
5. Luffing Jib Down Limit . . . . .	3-31
6. Maximum Bail Limit . . . . .	3-32
7. Minimum Bail Limit . . . . .	3-32
Seat Controls . . . . .	3-32
Preparing Crane for Operation . . . . .	3-33
Operation . . . . .	3-33
Engine Startup . . . . .	3-33
Boom Hoist Operation . . . . .	3-36
Luffing Hoist Operation . . . . .	3-37
Swing Operation . . . . .	3-38
Load Drum Operation . . . . .	3-39
Liftcrane Operation — (With Free Fall Off) . . . . .	3-39
Liftcrane Operation — Free Fall . . . . .	3-39
Clamshell Operation . . . . .	3-41
Travel Operation . . . . .	3-42
Luffing Jib Setup Mode . . . . .	3-44
Stopping Engine/ Leaving Crane Unattended . . . . .	3-45
Remote Controls . . . . .	3-45
General . . . . .	3-45
Set-Up Remote Control . . . . .	3-45
1 – Power Switch . . . . .	3-46
2 – Stop Switch . . . . .	3-46
3 – Gantry Cylinders . . . . .	3-46
4 – Back Hitch Pins . . . . .	3-46
Manual Controlled Handles . . . . .	3-47



Crawler Pin Controls .....	3-47
Carbody Jack Controls .....	3-47
Displays .....	3-48
Display Controls .....	3-48
1 – Rated Capacity Indicator/Limiter Display .....	3-48
2 – Main Display .....	3-48
3 – Display Touch Pad Controls .....	3-48
4 – Display Select Buttons .....	3-48
5 – Select Buttons .....	3-48
6 – Enter/Exit Buttons .....	3-48
7 – Confirm Button .....	3-48
Display Brightness and Color Contrast .....	3-48
Factory Default Display Settings .....	3-48
Blank Display .....	3-48
Main GUI Display Format .....	3-49
Screen Prompts .....	3-49
Menu Screen .....	3-50
Information Screen .....	3-50
Boom to Luffing Jib Working Angle .....	3-50
Wind Speed Indicator .....	3-50
Mast Angle .....	3-50
Hydraulic Tank .....	3-51
Battery .....	3-51
Engine (all) .....	3-51
Crane Faults .....	3-51
Tier 4 Engine Fault .....	3-51
Diagnostic Screens .....	3-54
Diagnostic Screen Component Icons .....	3-54
Tier 4 Engine Diagnostic Information .....	3-55
Drum Diagnostic Screens .....	3-55
Swing Diagnostic Screen .....	3-56
Travel Diagnostic Screen .....	3-56
Accessory Diagnostic Screen .....	3-57
Function Mode Screens .....	3-57
Drum Functions .....	3-58
Swing Functions .....	3-58
Travel Functions .....	3-58
Remote Control Functions .....	3-58
Multiple Points or Load Pin Disable Functions .....	3-58
Swing or Track Speed Limits .....	3-58
Drum Functions .....	3-59
Swing Torque .....	3-59
Boom or Swing Motion Limiter Mode .....	3-60
Remote Control .....	3-60
Multiple Points or Load Pin Disable Functions .....	3-60
Fan Function .....	3-60
CAN Bus Diagnostic Screen .....	3-62
Packet Information .....	3-62
Digital Output Disable Fault .....	3-62
Engine Node Status .....	3-62
Crane Status .....	3-62
Boom Node Status .....	3-63
Camera Screen (Optional) .....	3-68
Pressure Test and Calibration Screen .....	3-68
Pressure Sender Test .....	3-68
Control Calibration .....	3-69
High Pressure Test .....	3-69

Charge Pressure Test .....	3-70
Wind Conditions .....	3-71
Preparation for Cold Weather .....	3-73
Crane Limitations .....	3-73
Wire Rope .....	3-73
Cold Weather Starting Aid .....	3-73
Coolant and Oil Pan Heaters .....	3-73
Cooling System .....	3-73
Batteries .....	3-73
Engine Oil .....	3-73
Fuel Oil .....	3-73
Gear Oil .....	3-73
Hydraulic Cranes .....	3-73
Hydraulic Oil .....	3-74
General .....	3-74
Cold Weather Heater Package .....	3-75
General .....	3-75
Heaters .....	3-75
Turning Heaters On .....	3-75
Turning Heaters Off .....	3-75
Circuit Breakers .....	3-75
Cold Weather Package — Past .....	3-76
Cold Weather Package — Current .....	3-77

14001060

# SECTION 3 OPERATING CONTROLS AND PROCEDURES

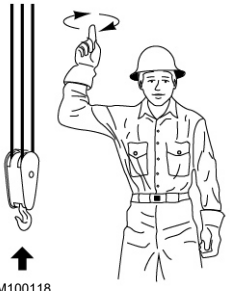
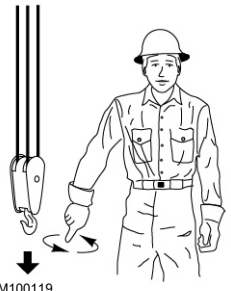

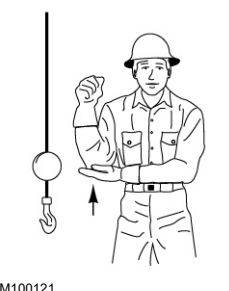
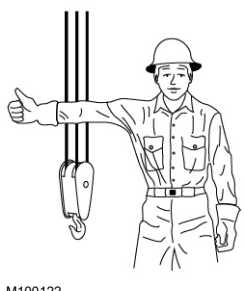
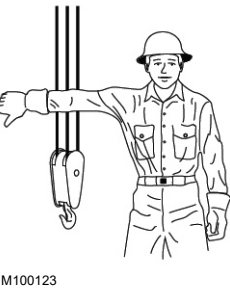

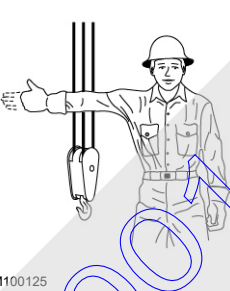
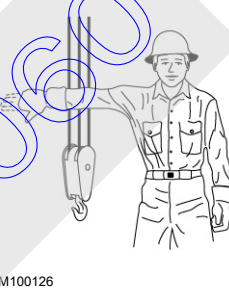
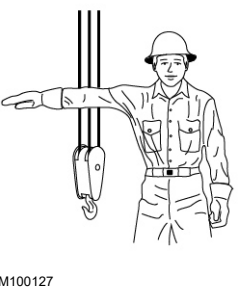
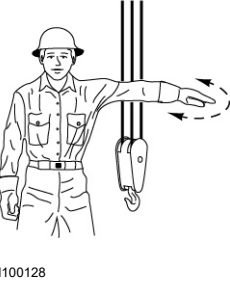
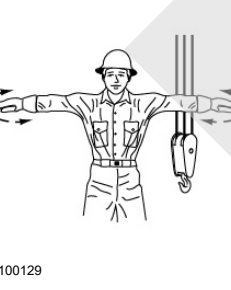
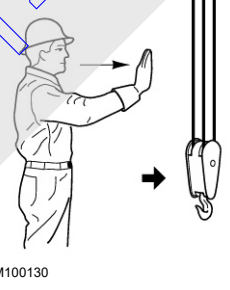
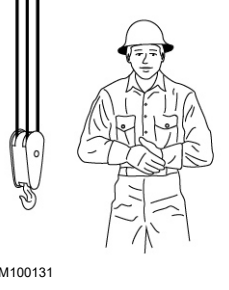
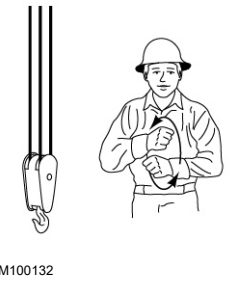
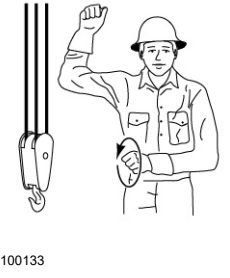
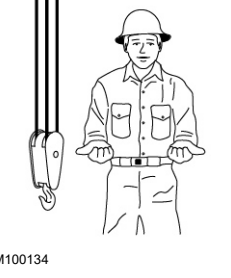
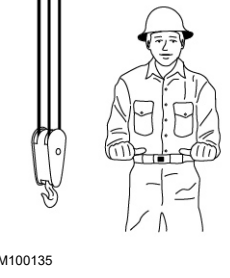
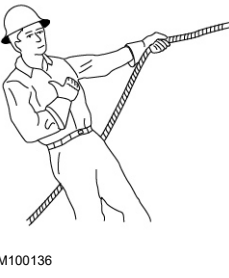
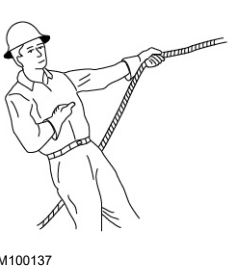
*THIS SECTION STARTS ON THE NEXT PAGE*

14001060

# STANDARD HAND SIGNALS FOR CONTROLLING CRANE OPERATIONS

The following standard hand signals comply with ASME B30.5-2014.

**Table 3-1 Standard Hand Signals For Controlling Crane Operations**

<b>1</b>	<b>2</b>	<b>3</b>	<b>4</b>	<b>5</b>
 <p>M100118</p>	 <p>M100119</p>	 <p>M100120</p>	 <p>M100121</p>	 <p>M100122</p>
<b>6</b>	<b>7</b>	<b>8</b>	<b>9</b>	<b>10</b>
 <p>M100123</p>	 <p>M100124</p>	 <p>M100125</p>	 <p>M100126</p>	 <p>M100127</p>
<b>11</b>	<b>12</b>	<b>13</b>	<b>14</b>	<b>15</b>
 <p>M100128</p>	 <p>M100129</p>	 <p>M100130</p>	 <p>M100131</p>	 <p>M100132</p>
<b>16</b>	<b>17</b>	<b>18</b>	<b>19</b>	<b>20</b>
 <p>M100133</p>	 <p>M100134</p>	 <p>M100135</p>	 <p>M100136</p>	 <p>M100137</p>

Reprinted from **ASME B30.5-2014**, by permission of the American Society of Mechanical Engineers. All Rights Reserved.

Item	Description
1	<b>HOIST</b> —With forearm vertical, forefinger pointing up, move hand in small horizontal circles.
2	<b>LOWER</b> —With arm extended downward, forefinger pointing down, move hand in small horizontal circles.
3	<b>USE MAIN HOIST</b> —Tap fist on head. Then use regular signals.
4	<b>USE WHIPLINE (Auxiliary Hoist)</b> —Tap elbow with one hand. Then use regular signals.
5	<b>RAISE BOOM</b> —Arm extended, fingers closed, thumb pointing upward.
6	<b>LOWER BOOM</b> —Arm extended, fingers closed, thumb pointing downward.
7	<b>MOVE SLOWLY</b> —Use one hand to give any motion signal and place other hand motionless in front of hand giving the motion signal (hoist slowly shown as an example).
8	<b>RAISE BOOM &amp; LOWER LOAD</b> —With arm extended, thumb pointing up, flex fingers in and out as long as load movement is desired.
9	<b>LOWER BOOM &amp; RAISE LOAD</b> —With arm extended, thumb pointing down, flex fingers in and out as long as load movement is desired.
10	<b>SWING</b> —Arm extended, point with finger in direction of swing of boom.
11	<b>STOP</b> —Arm extended, palm down, move arm back and forth horizontally.
12	<b>EMERGENCY STOP</b> —Both arms extended, palms down, move arms back and forth horizontally.
13	<b>TRAVEL</b> —Arm extended forward, hand open and slightly raised, make pushing motion in direction of travel.
14	<b>DOG EVERYTHING</b> —Clasp hands in front of body.
15	<b>TRAVEL (Both Tracks)</b> —Use both fists in front of body, making a circular motion about each other, indicating direction of travel forward or backward. (For Land Cranes Only).
16	<b>TRAVEL (One Track)</b> —Lock the track on side indicated by raised fist. Travel opposite track in direction indicated by circular motion of other fist, rotated vertically in front of body. (For Land Cranes Only).
17	<b>EXTEND BOOM (Telescoping Booms)</b> —Both fists in front of body with thumbs pointing outward.
18	<b>RETRACT BOOM (Telescoping Boom)</b> —Both fists in front of body with thumbs pointing toward each other.
19	<b>EXTEND BOOM (Telescoping Boom) — One Hand Signal.</b> One fist in front of chest with thumb tapping chest.
20	<b>RETRACT BOOM (Telescoping Boom) — One hand signal.</b> One fist in front of chest, thumb pointing outward and heel of fist tapping chest.

### SYMBOL IDENTIFICATION

The following symbols are used on the control consoles to identify the operating controls and their operation.









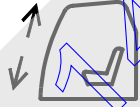

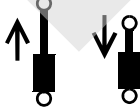

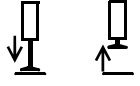
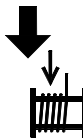
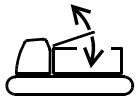

Air Conditioning		Data, Confirm	
Air Conditioning Temperature		Data, Select	
Alert, Safety		Decrease/Increase	
Blower (Fan)		Display Identifier (1 or 2)	
Cab Tilt		Drum	
Cylinders, Live Mast – Extend or Retract		Drum – Lower (Load, Boom, Luffing Jib, or Mast) (depends on drum use.)	
Cylinders, Jacking – Extend or Retract		Drum – Raise (Load, Boom, Luffing Jib, or Mast) (depends on drum use.)	
Cylinders – Live Mast		Drum Number	

FIGURE 3-1

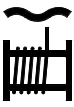















Drum - Free Fall		Engine Start	
Enable		Engine Stop	
Energize (turn on)		Engine Temperature	
Engine		Enter	
Engine, Battery Voltage		Exit	
Engine, Fuel		Heater/Defroster	
Engine Pressure		Horn	
Engine Run		Light, Panel	

FIGURE 3-1 continued




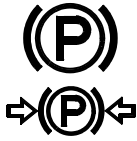





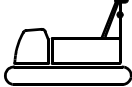

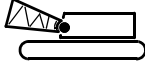






Light, Flood		Park On	
Lighter		Pins – Disengage	
Limit Bypass		Pins – Engage	
Limit Bypass, Luffing Jib		Pins – Back Hitch	
On/Start and Off/Stop		Pins – Boom Hinge	
Off/Stop		Remote Control	
On/Start		Scroll (up, down, and sideways)	
Park Off		Setup	

FIGURE 3-1 continued


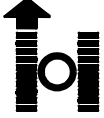

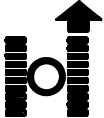

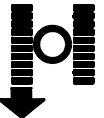

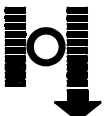
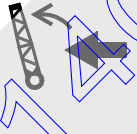
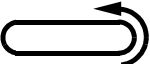
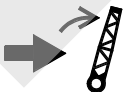

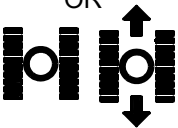



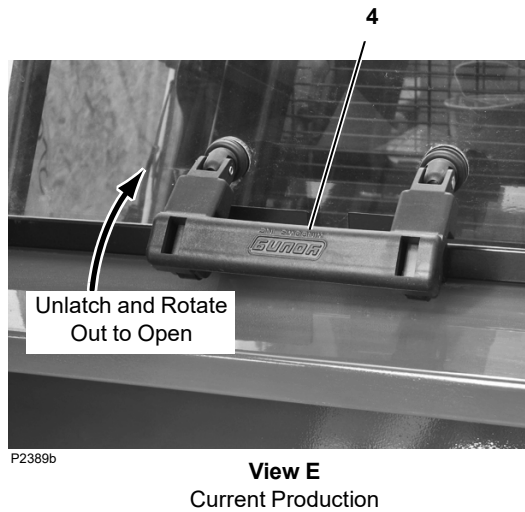
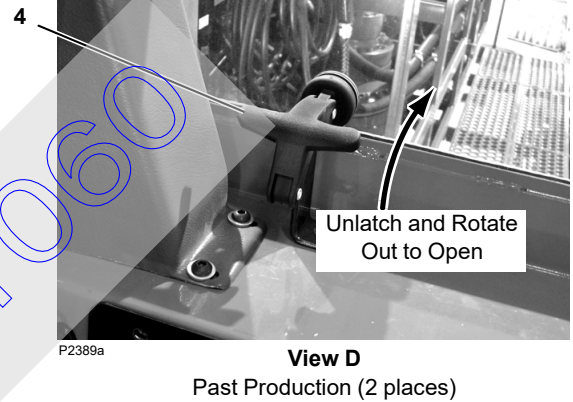
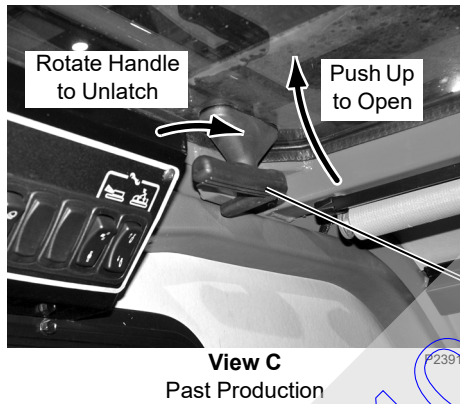
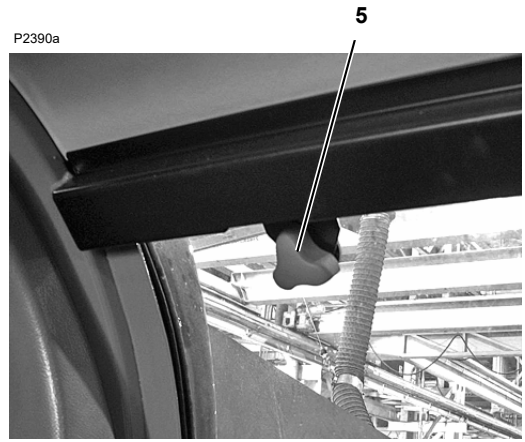
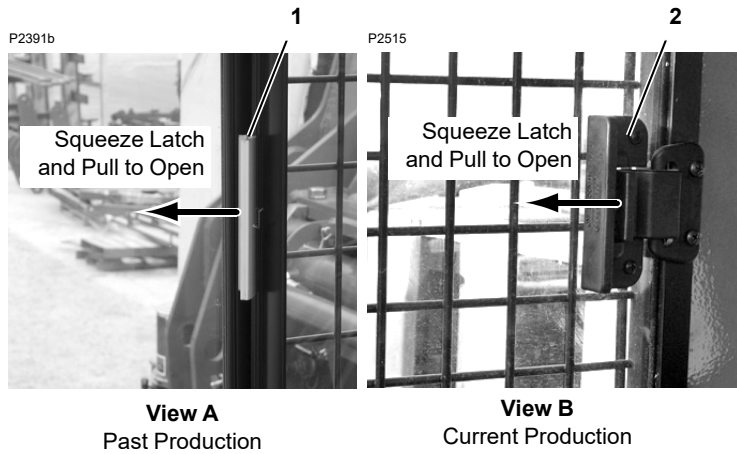
Speed, Fast		Travel Direction Forward – Left Crawler	
Speed, Slow		Travel Direction Forward – Right Crawler	
Stop (emergency)		Travel Direction Reverse – Left Crawler	
Swing		Travel Direction Reverse – Right Crawler	
Swing Left		Travel Speed	
Swing Right		Windshield Wiper – Overhead	
Travel	OR 	Windshield Wiper – Front with Washer	
Travel Cruise		DPF Inhibit On (Tier 4)	

FIGURE 3-1 continued

**THIS PAGE INTENTIONALLY LEFT BLANK**

14001060



Item	Description
1	Latch (right-side window)
2	Latch (right-side and roof window)
3	Latch (roof window)
4	Latch (rear window)
5	Knob

3

FIGURE 3-2

## CAB WINDOW OPERATION

See [Figure 3-2](#), in the following procedures.

### Opening Windows for Ventilation

#### *Past Production Cab*

The right-side and rear windows can be opened for ventilation as shown in Views A and D.

For non-European cabs only, the roof window can be opened for ventilation as shown in View C.

#### *Current Production Cab*

The right-side and rear windows can be opened for ventilation as shown in Views B and E.

For non-European cabs only, the roof window can be opened for ventilation in the same manner as the right-side window (View B).

**NOTE:** European code requires a roof window that cannot be opened.

### Exiting Cab in Emergency

If you cannot exit the cab through the sliding door, proceed as follows:

#### *Past Production Cab Only*

Remove knobs (5) at top of rear window, open latches (4) at bottom of rear window, push rear window out, and exit cab through window opening.

#### *Current Production Cab Only*

While seated in the cab seat, “kick out” the front window and exit the cab through the opening. The front window is attached to the cab frame with offset rubber molding that allows the window to be “kicked out”.

## OPERATING CONTROLS



### WARNING

**To prevent death or serious personal injury:**

- Read and thoroughly understand instructions in this section, in Section 2, and in Capacity Chart Manual.
- Contact your Manitowoc dealer for assistance if you do not clearly understand any operating procedure.

### General

The purpose of the following instructions is to familiarize qualified personnel with the location and function of the operating controls on this crane. This section also contains safety information and a description of operation for each crane function.

Depending on the options your crane is equipped with, some controls identified in this section will not apply.

**A — Engine Controls (see Page 3-14)**

- A1 Engine Ignition Switch
- A2 Engine Emergency Stop Switch
- A3 Engine Hand Throttle
- A4 Engine Foot Throttle
- A5 Engine Clutch Lever \*
- A6 Battery Disconnect Switch\*
- A7 Regen / Normal / Regen Inhibit Switch

**B — Accessory Controls (see Page 3-18)**

- B1 Overhead Windshield Wiper Switch
- B2 Front Windshield Wiper-Washer Switch
- B3 Climate Control Panel
- B4 Crane Work Lights Switch
- B5 Panel Light Switch
- B6 Boom Pins Switch
- B7 Mast Switch
- B8 Dome Light Switch
- B9 Overhead Fan Switch
- B10 Horn Switch
- B11 Cab Tilt Switch
- B12a Cigarette Lighter Receptacle (12 Volt)
- B12b Power Supply Receptacle (12 Volt)
- B13 Programming Receptacle
- B14 Fire Extinguisher
- B15 Radio/CD Player (optional)
- B16 Overhead Sun Shade and Tinted Visor

B17 Machinery Heaters\*

B18 Cup Holder

**C — Indicators (see Page 3-21)**

- C1 Fuel Level
- C2 Engine Coolant Temperature
- C3 Engine Oil Pressure
- C4 Battery Voltage
- C5 Drum Rotation Indicators
- C6 Rear View Mirror
- C7 Boom Angle Indicator \*
- C8 Cab Beacon
- C9 Crane Levels \*

**D — Special Controls (see Page 3-22)**

- D1 Rated Capacity Indicator/Limiter Display and Indicator Lights
- D2 Main Display
- D3 Display Touch Pad Controls
- D4 Limit Bypass Switch \*\*
- D5 Luffing Jib Limit Bypass Switch \*\*
- D6 Seat Switch

**E — Boom Hoist Controls (see Page 3-26)**

- E1 Drum 4 (Boom Hoist) Park Switch
- E2 Drum 4 (Boom Hoist) Handle

**F — Load Drum Controls (see Page 3-27)**

- F1 Drum 1 (Front Drum) Park Switch
- F2 Drum 2 (Rear Drum) Park Switch
- F3 Drum 3 (Auxiliary/Luffing Jib) Park Sw
- F4 Drum 1 (Front Drum) Handle
- F5 Drum 2 (Rear Drum) Handle
- F6 Drum 3 (Auxiliary/Luffing Jib) Handle
- F7 Drum 1 Working Brake Pedal
- F8 Drum 2 Working Brake Pedal

**G — Swing Controls (see Page 3-28)**

- G1 Swing Park Switch
- G2 Swing Handle
- G3 Swing Holding Brake Switch

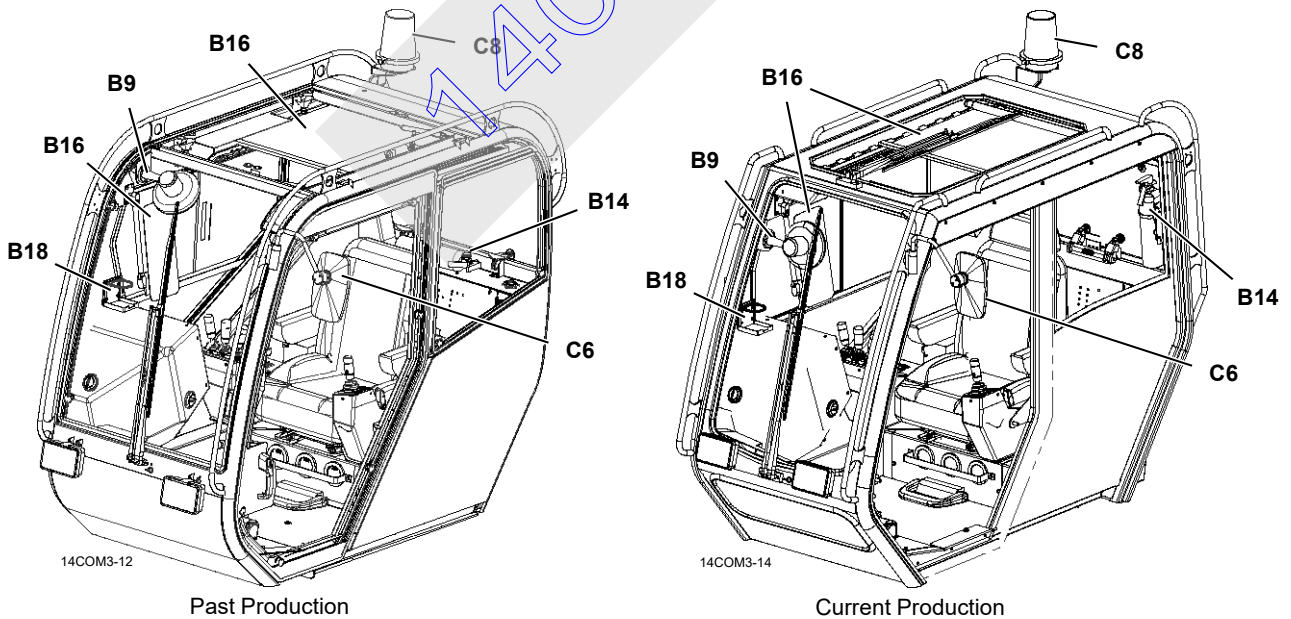


FIGURE 3-3

14COM3-4

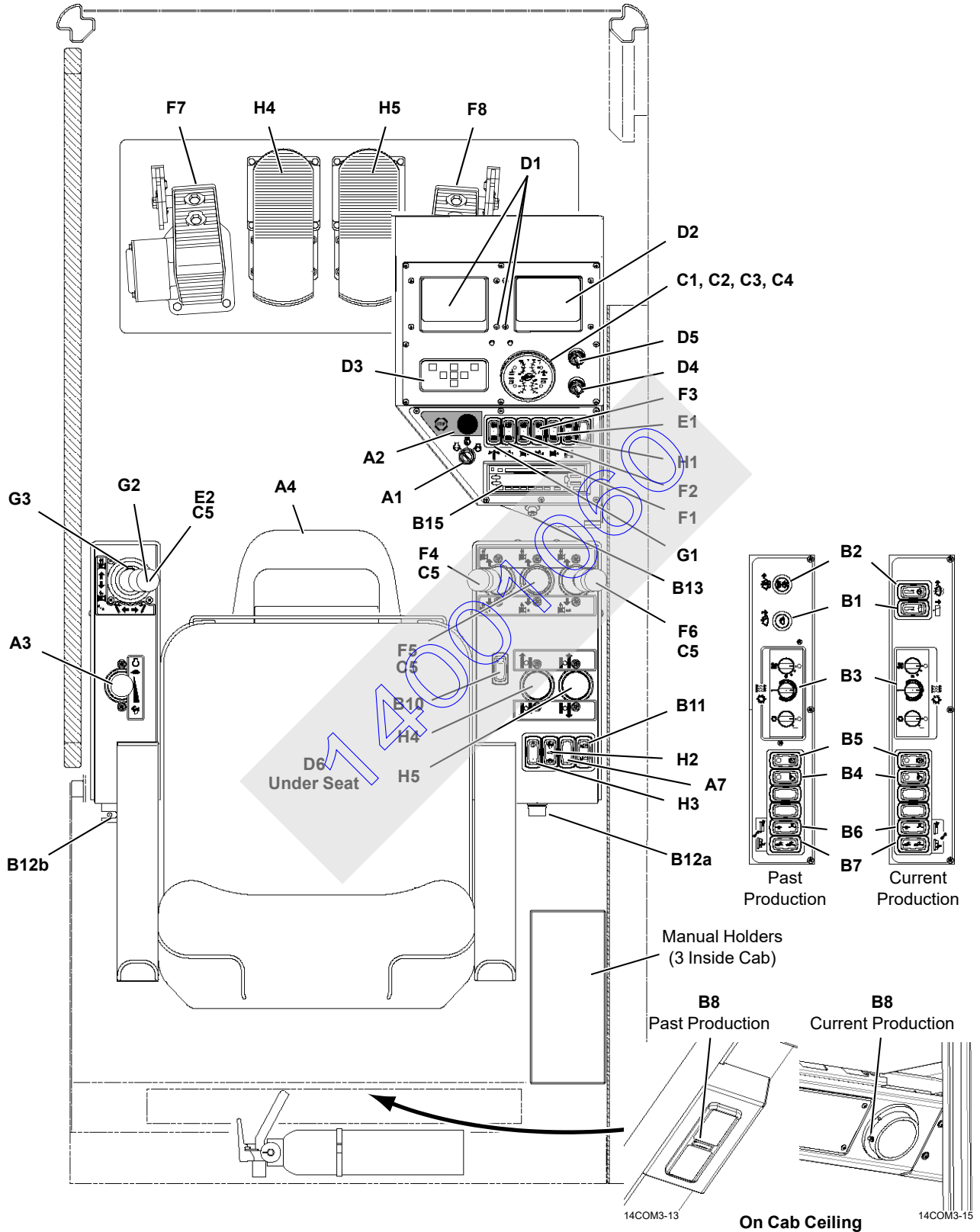


FIGURE 3-3 continued



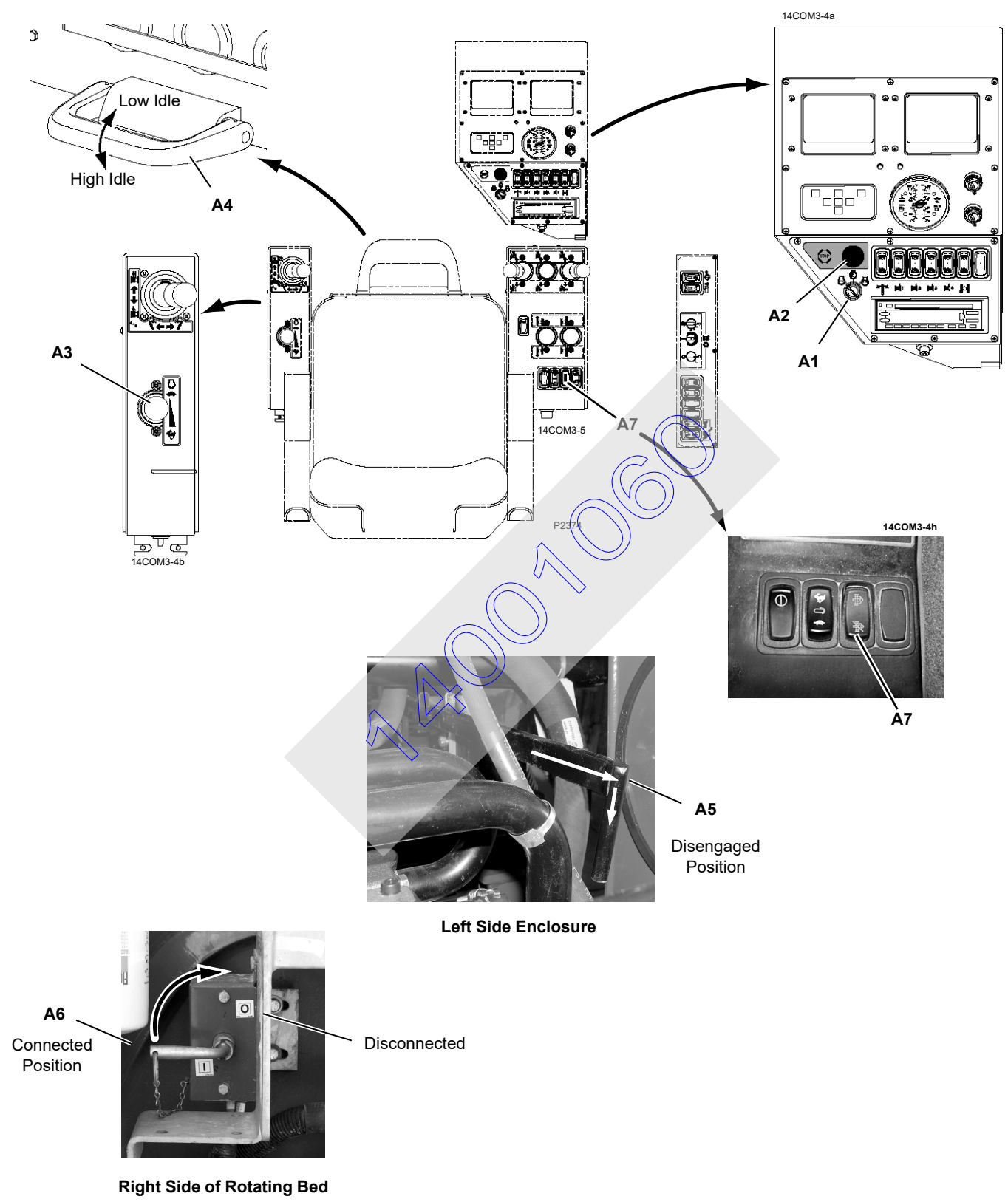


FIGURE 3-4

## CONTROLS IDENTIFICATION AND FUNCTION



### WARNING

#### Unauthorized Startup!

Always STOP engine and remove key before leaving crane unattended. This practice will prevent unauthorized personnel from operating crane.

## A – Engine Controls

See [Figure 3-4](#) for the engine controls.



### DANGER

#### Engine Explosion Hazard!

Do not spray any combustible starting aid (ether) into engine air intake.

This engine has air-intake heaters that will ignite ether resulting in a severe explosion and/or burns.

### A1. Engine Ignition Switch

Insert key.

Turn CLOCKWISE to RUN position to activate the crane's electric circuits.

Turn fully CLOCKWISE to START engine. **RELEASE to RUN position as soon as engine starts.**

Rotate COUNTERCLOCKWISE to STOP engine and turn off crane's electric system.

**NOTE:** Engine diagnostic faults appear on engine screen (see Main display in this section) when ignition switch is in run position. Engine faults must go away when engine is started. See engine manufacturer's operating instructions manual for engine diagnostic information.

The engine has an automatically controlled air-intake heater to aid in startup during cold weather.

### A2. Engine Emergency Stop Switch

Push knob DOWN to STOP engine only in an emergency — for example, if a crane function does not stop when control handle is released to off (center position) or any other uncontrolled motion of a crane function is observed.

**Beware** — When knob is pushed down, engine stops, brakes apply, and any **functions being operated come to an abrupt stop.**

**NOTE** The knob must be pulled up before the engine can be restarted.

If the emergency stop switch has been activated, test all disk brakes for proper operation before putting the crane back in service. See Section 2 of Service Manual for procedure.

Use engine ignition switch (A1) to stop engine for normal operating conditions.

### A3. Engine Hand Throttle

Pull handle BACK to INCREASE engine speed.

Push handle FORWARD to DECREASE engine speed.

**NOTE:** The selected engine speed is maintained when the handle is released.

Speed of the crane functions depends on engine speed and on how far the control handles are moved in either direction from off.

Engine speed must be fast enough to provide sufficient power for the work being done. **Engine can stall under load if engine speed is too slow.**

Engine speed cannot be increased while the following faults are on. Engine speed can be reduced, but cannot be increased again until the faults are off. See [Page 3-53](#) for fault identification.

- Fault 40, High Vacuum
- Fault 61, Dirty Return Filter

### A4. Engine Foot Throttle

PRESS foot throttle to INCREASE engine speed above the hand throttle setting.

RELEASE foot throttle to DECREASE engine speed to idle or to the hand throttle setting.

### A5. Engine Clutch Lever

Pull clutch lever UP and push IN to ENGAGE the clutch.

Pull clutch lever OUT and push DOWN to DISENGAGE the clutch.

## CAUTION

### Engine Damage!

To avoid possible engine fault codes and undesirable operation, make sure engine ignition switch has been off five minutes before disconnecting batteries.

Do not rely on this switch to protect crane's electronic systems when welding. Disconnect battery cables at batteries before welding.

**A6. Battery Disconnect Switch**

Turn handle COUNTERCLOCKWISE to CONNECT battery circuit.

Turn handle CLOCKWISE to DISCONNECT battery circuit for following reasons:

- When servicing crane's electrical control system
- If desired, to prevent batteries from discharging when the crane is stored for extended periods of time
- If desired, to prevent crane from being started by unauthorized personnel

**CAUTION****Engine Damage!**

To avoid possible engine fault codes and undesirable operation, make sure engine ignition switch has been off five minutes before disconnecting batteries.

Do not rely on this switch to protect crane's electronic systems when welding. Disconnect battery cables at batteries before welding.

Pull handle out when in the disconnect position to keep unauthorized personnel from connecting the battery and starting the crane.

**A7. DPF Switch**

**NOTE:** DPF = Diesel particulate filter (only on cranes with Tier 4 engine).

The DPF switch is a three position switch. Top position is momentary. Center and bottom position is maintained.

CENTER position is for NORMAL engine operation. Regeneration of the DPF will occur automatically.

Press TOP of rocker to START manual stationary regeneration. Release switch back to center position. Cummins ECM will control a DPF regeneration if necessary. It is normal for the DPF High Temperature lamp to illuminate.

Perform a stationary regeneration only if indicated by the DPF icon in the Tier 4 Engine Information Screen (see [Tier 4 Engine Diagnostic Information](#) for details).

**NOTE:** A guard over the top of the rocker prevents accidental manual regeneration of the DPF.

Press BOTTOM of rocker to INHIBIT active regeneration. The amber LED in the rocker will glow.

Use INHIBIT only for special circumstances where it is desirable to disable active regeneration. Prolonged engine operation with INHIBIT on will cause the DPF to fill with soot. Too much soot could cause the engine to stop. If that occurs it will be necessary to clean the DPF before the engine can be restarted.

See Engine Manufacturer's Manual for additional information regarding stationary regeneration and DPF inhibit operating instructions.

**THIS PAGE INTENTIONALLY LEFT BLANK**

14001060

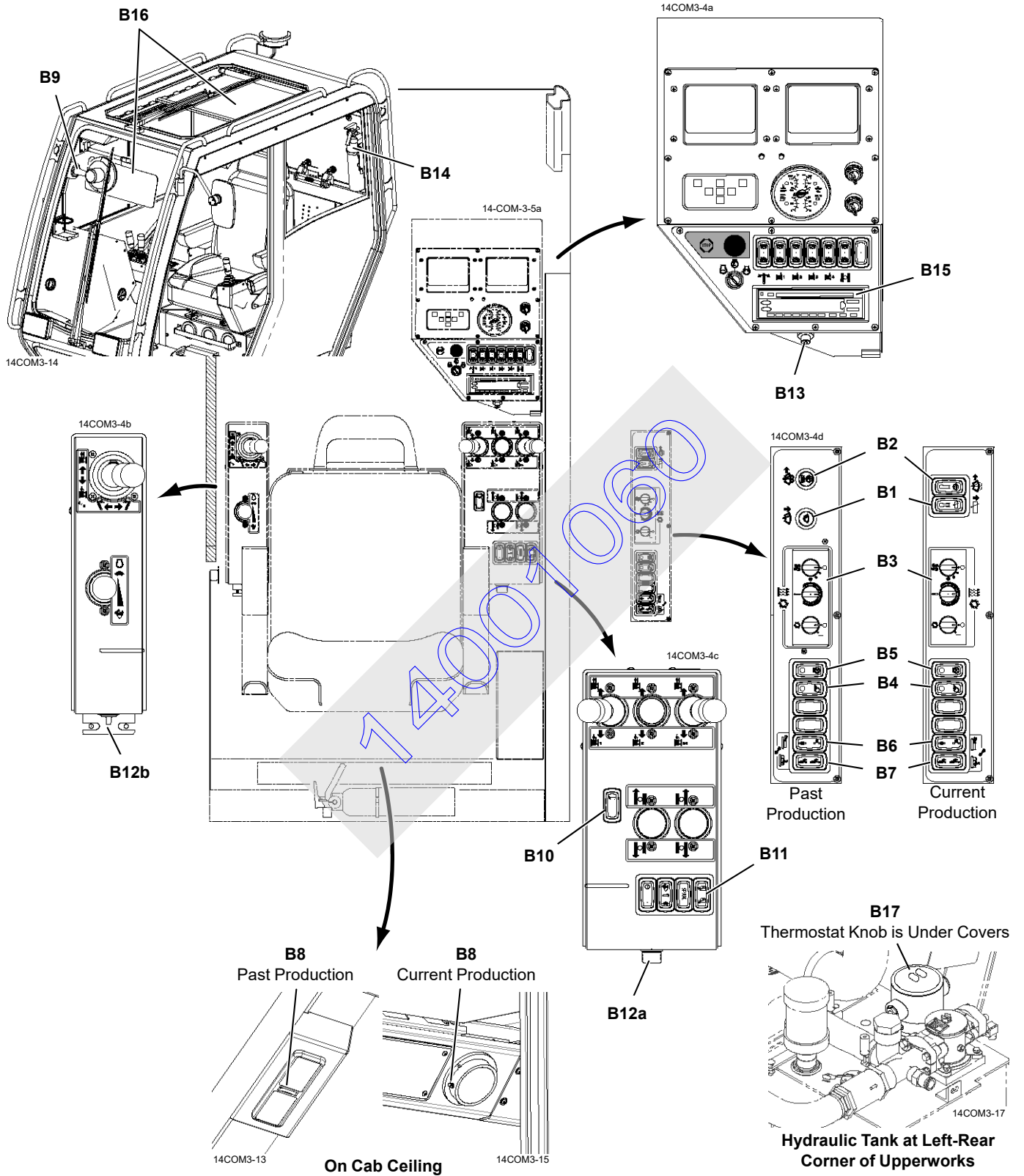


FIGURE 3-5

**B – Accessory Controls**

See [Figure 3-5](#) for the accessory controls.

**B1. Overhead Windshield Wiper Switch**

**B2. Front Windshield Wiper-Washer Switch**

PAST PRODUCTION:

- Counterclockwise — OFF
- Clockwise — INTERMITTENT depending how far knob is turned:
- Clockwise (1st detent) — LOW speed
- Clockwise (2nd detent) — HIGH speed
- PRESS front windshield wiper switch to SPRAY washer fluid onto front window

CURRENT PRODUCTION:

- Toggle fully down — OFF
- Toggle up — INTERMITTENT depending how far toggle is moved:
- Toggle fully up — HIGH speed
- PRESS top end of front windshield wiper switch to SPRAY washer fluid onto front window

**NOTE:** The windshield washer tank is mounted at rear of cab support. Fill the tank with a quality brand washing solution that **will not freeze during cold weather.**

**B3. Climate Control Panel**

Three controls provides cab temperature control.

**BLOWER CONTROL** — Rotate blower control clockwise to increase fan speed. A LED illuminates when control is ON. The selected fan speed is maintained until control is rotated fully counter-clockwise to OFF.

**TEMPERATURE CONTROL** — Turn temperature control counter-clockwise to lower temperature setting. Turn temperature control clockwise to raise temperature setting. The system maintains cab temperature as close as possible to selected temperature.

**CLIMATE CONTROL** — Rotate climate control clockwise to turn control ON. Rotate climate control counter-clockwise to turn control OFF. A LED illuminates when control is ON.

**NOTE:** The shut-off valves in the heater hoses at the engine must be open for heater operation.

The shut-off valves can be closed to block hot water flow through the heater core during warm weather.

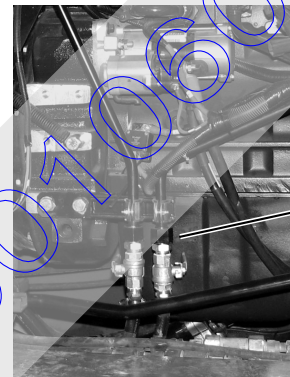
P2369



**Past Production**  
Heater shut-off valve shown OPEN.  
Turn handle 90° to CLOSE.

2 Places Rear of Engine

**FIGURE 3-6**



**Current Production**  
Heater shut-off valves shown OPEN.  
Turn handle 90° to CLOSE.

2 Places Front of Engine

**FIGURE 3-7**

**B4. Crane Work Lights Switch**

This switch controls work lights mounted on front of cab.

Press TOP of rocker to TURN ON work lights.

Press BOTTOM of rocker to TURN OFF work lights.

**B5. Panel Light Switch**

Press TOP of rocker to TURN ON panel lights.

Press BOTTOM of rocker to TURN OFF panel lights.



**B6. Boom Pins Switch****WARNING****Falling Load Hazard!**

To prevent boom or boom butt from falling off crane:

- Do not disengage boom hinge pins until boom butt is properly supported on stands at ground level. Boom/boom butt could fall off crane.
- Read Boom Rigging Guide in Section 4.

Enable Set Up mode.

Press and hold TOP of rocker to DISENGAGE boom hinge pins.

RELEASE rocker to ENGAGE boom hinge pins.

**B7. Mast Switch**

Enable Set Up mode.

Press and hold TOP of rocker to EXTEND mast arm cylinders.

Release toggle to CENTER to STOP cylinders. Valves on the cylinders lock them in position.

Press and hold BOTTOM of rocker to RETRACT mast arm cylinders.

Read Crane Assembly and Disassembly in Section 4 for live mast raising and lowering instructions.

**B8. Dome Light Switch**

Dome light switch is part of light fixture on ceiling of cab.

Press FRONT of rocker to TURN ON dome light.

Press REAR of rocker to TURN OFF dome light.

**B9. Overhead Fan Switch**

Fan has a three position switch: *off, low, high*. Adjust fan's position to direct air flow as desired.

**B10. Horn Switch**

A horn switch is provided on right side console. Use horn **when necessary to warn or signal personnel while crane is being operated or serviced.**

Press and hold FRONT of rocker to TURN ON horn.

RELEASE rocker to TURN OFF horn.

**B11. Cab Tilt Switch**

Press and hold FRONT of rocker to RAISE front of cab.

CENTER rocker to LOCK cab in position.

Press and hold BOTTOM of rocker to LOWER front of cab.

**WARNING****Moving Cab Hazard!**

Warn personnel to stand clear of operator's cab while tilting.

- Personnel can lose balance and fall
- Personnel can be crushed between operator's cab and machinery enclosure

**B12a. Cigarette Lighter Receptacle**

Push IN to TURN ON lighter.

The lighter will pop out automatically when the coil is hot.

This receptacle can be used to power other 12 volt components.

**B12b. Power Supply Receptacle**

Provided to power/charge a 12 volt cell phone or other component.

**B13. Programmable Receptacle**

Programmable receptacle is for connecting laptop computer for loading software or programming functions.

**B14. Fire Extinguisher**

A fire extinguisher is located behind the seat in operator's cab and on the crane rotating bed (optional).

**B15. Radio/CD Player (optional)**

See manufacturer's instructions.

**B16. Overhead Sun Shade and Tinted Visor**

An overhead sun shade is provided for top window. A tinted visor (optional) is provided for front window. Position sun shade and tinted visor as desired to shade sunlight.

**B17. Machinery Heaters**

Hydraulic tank has two thermostatically controlled heaters (120 or 240 volt) designed to keep oil temperature 30°F (17°C) warmer than ambient temperature.

To aid engine startup in cold weather, plug in heaters at shutdown; unplug heaters at startup.



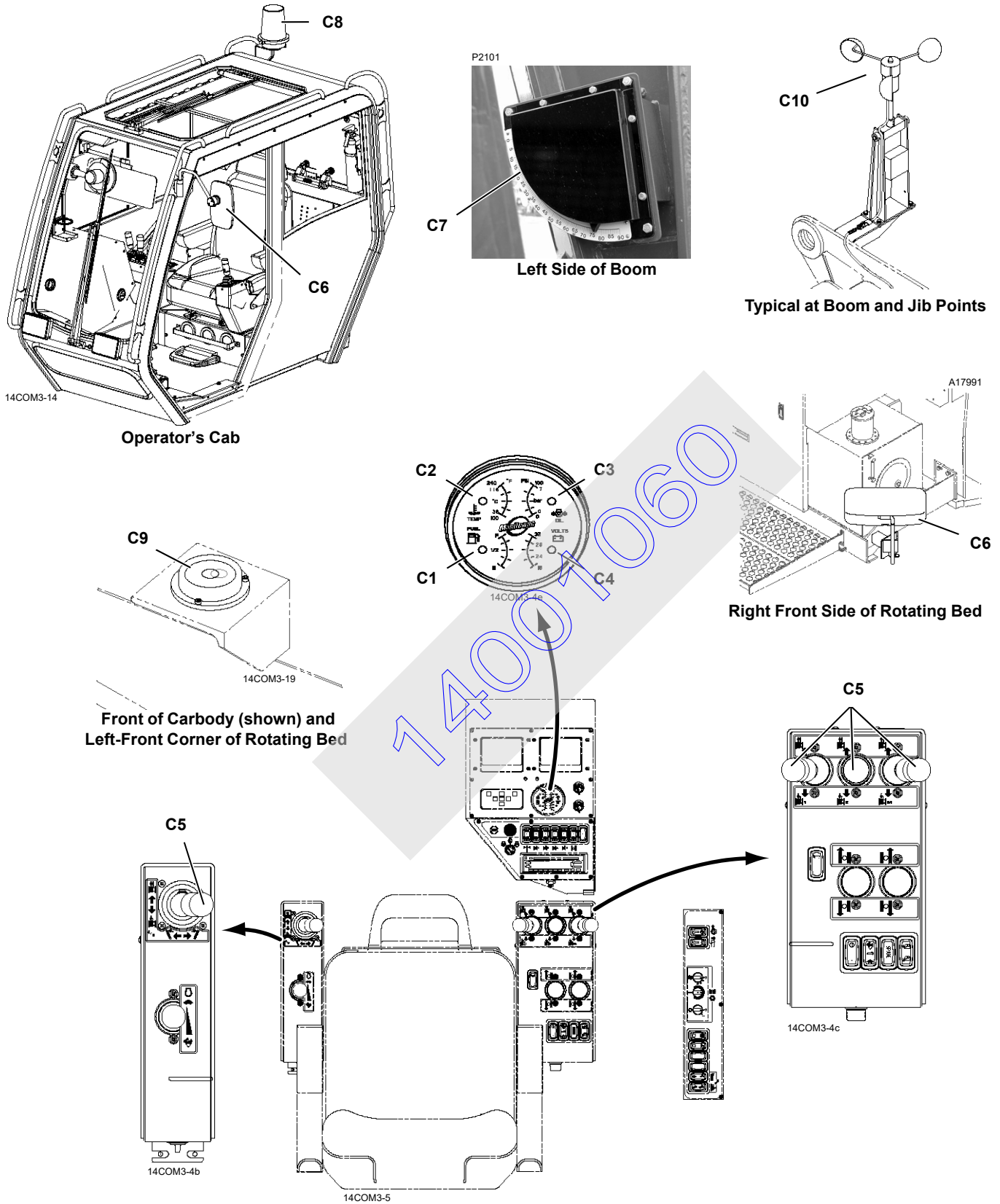


FIGURE 3-8

**C – Indicators**

See [Figure 3-8](#) for the indicators.

**C1. Fuel Level**

Fuel level indicator is located in circular gauge in front panel. Indicates amount of fuel remaining in fuel tank.

**C2. Engine Coolant Temperature**

See engine manual for operating specifications.

**C3. Engine Oil Pressure**

See engine manual for operating specifications.

**C4. Battery Voltage**

Indicates condition of battery charging system.

**C5. Drum Rotation Indicators**

Pin-type actuators located under all drum handle covers. They move UP and DOWN to signal the operator, by feel, that corresponding drum is turning. Indicator movement corresponds to drum speed.

**C6. Rear View Mirrors**

Adjustable rear view mirrors mounted on operator’s cab and at right front side of rotating bed allow operator to view rear of crane. Mirrors can be rotated inward for shipping.

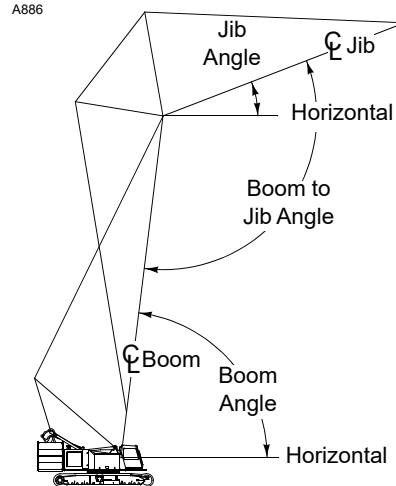
**C7. Boom Angle Indicator**

**! WARNING**  
**Overload Hazard!**

Use boom angle indicator only as a guide to position boom near angle corresponding to radius for given load. In all cases, radius shall govern capacity. Exceeding radius given in capacity chart can result in tipping or structural damage.

Shows the angle of boom in degrees above horizontal. The boom, luffing jib, and mast angles can be viewed on Rated Capacity Indicator/Limiter display or Main display.

See [Figure 3-9](#) for identification of various boom and luffing jib angles.



**FIGURE 3-9**

**C8. Cab Beacon (optional)**

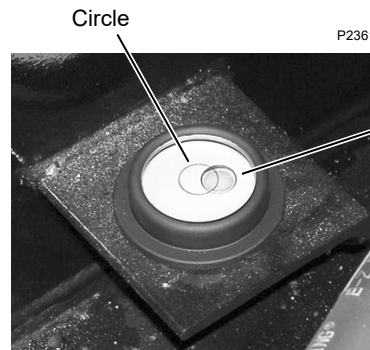
The beacon rotates with a flashing amber light and alarm whenever Rated Capacity Indicator/Limiter system is ON and the crane’s capacity is near an overload condition.

**C9. Upperworks Level**

**! WARNING**  
**Tipping Hazard!**

Unless otherwise specified on capacity chart, all crane operations must be performed with crane **level** to within one percent of grade in all directions – 1 ft in 100 ft (0,3 m in 30 m); otherwise, crane could tip.

Indicates crane levelness from front to rear and from side to side. The level is mounted on the left-front side of the rotating bed ([Figure 3-10](#)). The crane is level when the bubble is centered in the circle. The crane is one degree out of level when the bubble is touching the outside edge of the circle.



Bubble — Shown Approximately One-Half Degree Out of Level

**FIGURE 3-10**

**C10. Wind Speed Transmitter**

Wind speed at boom and jib points appears in wind speed screen (see Main display later in this section).

**D – Special Controls**

See [Figure 3-11](#) for the special controls.

**D1. Rated Capacity Indicator/Limiter Display and Indicator Lights**

Displays load lifting information and alerts operator to overload conditions. See separate Rated Capacity Indicator/Limiter Operation manual for detailed instructions.

**D2. Main Display**

Displays operating conditions, faults, and diagnostic information. See Main Display topic in this section for detailed instructions.

**D3. Display Touch Pad Controls**

Contains all the screen controls required to operate the Rated Capacity Indicator/Limiter display and Main display screens.

**D4. Limit Bypass Switch**



**WARNING**

When bypassing a limit, carefully follow instructions under Limit Devices topic in this section.

This switch bypasses the limits identified in [Table 3-2](#).

Insert key. Turn CLOCKWISE and HOLD to BYPASS reached operating limits. This position allows functions to be operated beyond the limits.

RELEASE to ENABLE operating limits. This position allows limits to stop functions in the normal manner. **Key must be in this position for all normal operation. Otherwise, structural damage can occur.**

Remove key to prevent unauthorized operation.

**D5. Luffing Jib Limit Bypass Switch**

**NOTE:** This switch is not provided on current production cranes.

This switch bypasses the limits identified in past production model 14000 [Table 3-2](#).

When the key is turned to the bypass position, the fault alarm is turned on (beep, beep, beep...) and setup mode operating limit icon (6, [Table 3-4](#)) is displayed in the information screen.

Insert Key. Turn CLOCKWISE to BYPASS corresponding limits. This position allows functions to be operated beyond the limits.

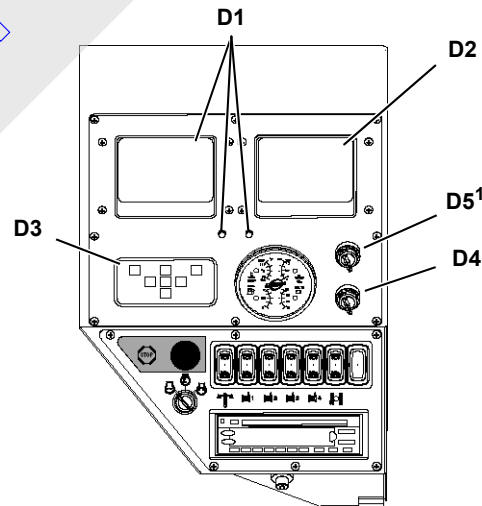
Turn COUNTERCLOCKWISE to ENABLE corresponding limits. This position allows limits to stop functions in the normal manner. **Key must be in this position for all normal operation. Otherwise, structural damage can occur.**

Remove key to prevent unauthorized operation.

**NOTE:** To bypass the limits for luffing jib setup on current production cranes without switch D5, proceed as follows:

- Select Luffing Jib Setup Mode (see [Page 3-44](#) for procedure)
- Rotate Limit Bypass Switch (D4) clockwise and hold
- Move the desired control handle (luffing hoist, boom hoist, or load drum) one at a time in the required direction
- The limits remain bypassed for 10 seconds after no control handle movement

14COM3-4a



<sup>1</sup> Not on current production

**FIGURE 3-11**

**D6. Seat Switch**

Prevents crane from being operated until operator is seated.

When operator is not seated, all control handles are inoperable, all parking brakes are applied, free fall is turned off, and travel cruise is turned off.

**Table 3-2 Bypassable Limit Identification Past Production Model 14000**

**This Table Applies to Cranes Equipped With Luffing Jib Limit Bypass Switch (D5)**

Limit	Past Production Console	
	Limit Bypass Switch (D4) (momentary)	Luffing Jib Limit Bypass Switch (D5) <sup>1</sup> (maintained)
Boom Maximum Up	No	No
Boom Down (optional)	Yes	No
Block-Up (each drum)	Yes	Yes
Bail, Max and Min (each drum)	Yes	No
Luffing Jib Maximum UP 1	Yes	Yes
Luffing Jib Maximum UP 2	Yes <sup>2</sup>	Yes <sup>2</sup>
Luffing Jib Maximum Down 1	Yes	No
Luffing Jib Maximum Down 2	No	No
Rated Capacity Limiter	Yes	Yes
Mast Too Far Forward	No	No

<sup>1</sup> Fault 6 alarm will remain on when this switch is in bypass position.

<sup>2</sup> Only when boom is below 50°

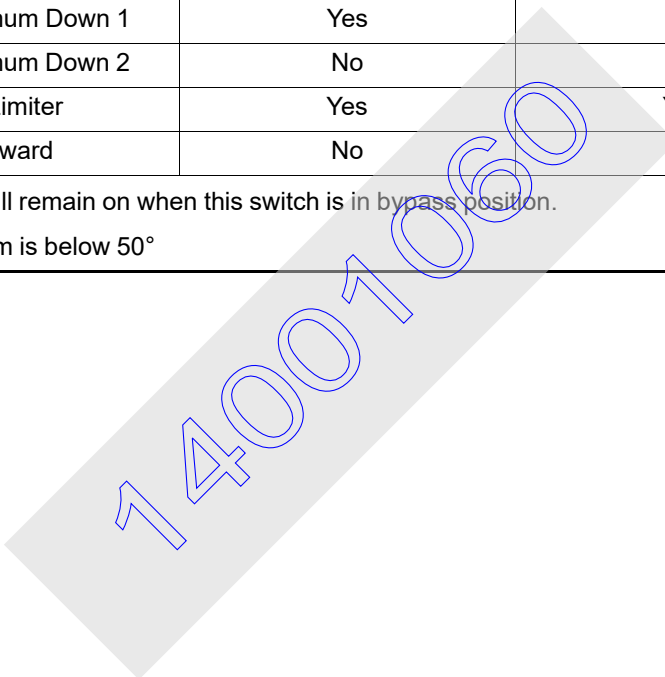


Table 3-3 Bypassable Limit Identification Current Production Model 14000

This Table Applies to Cranes Without Luffing Jib Limit Bypass Switch (D5)					
Limit	Limit Bypass Switch (D4) (momentary key switch)		Limit Bypass Switch (D4) (momentary key switch) Luffing Jib Setup Mode On <sup>1</sup>		External Override Switch <sup>2</sup>
	Non-CE	CE <sup>3</sup>	Non-CE	CE <sup>3</sup>	CE <sup>3</sup>
Boom Up	No	No	No	No	No
Block Up (each drum)	Yes	Yes <sup>6</sup>	Yes	Yes	No
Minimum Bail (each drum)	Yes	No	No	No	No
Luffing Jib Maximum Up 1	Yes	No	Yes	Yes	No
Luffing Jib Maximum Up 2	Yes	No	Yes <sup>4</sup>	Yes <sup>4</sup>	No
Luffing Jib Maximum Down 1	Yes	No	Yes	Yes	No
Luffing Jib Maximum Down 2	Yes <sup>5</sup>	No	Yes <sup>5</sup>	No	No
Mast Too Far Forward	No	No	No	No	No
Gantry Down	Yes	Yes	No	No	No
Boom Limiter <sup>8</sup>	Yes	Yes	No	No	No
Swing Limiter <sup>8</sup>	No	No	No	No	No
Rated Capacity Indicator/Limiter	Yes	Yes <sup>6</sup>	Yes	Yes <sup>6</sup>	Yes <sup>7</sup>

<sup>1</sup> Use only for rigging. See procedure described on [Page 3-44](#) for enabling [Luffing Jib Setup Mode](#)

<sup>2</sup> See Rated Capacity Indicator/Limiter Operation Manual

<sup>3</sup> CE = Cranes that comply with 2010 European requirements (see NOTE below)

<sup>4</sup> Only when boom is below 50°

<sup>5</sup> When this limit is contacted, operation will stop and you will not be able to continue lowering luffing jib. See Luffing Jib Max Down 2 on [Page 3-31](#) for detailed instructions

<sup>6</sup> Only if boom or luffing jib is below allowable angle given in Capacity Chart (while raising or lowering boom and luffing jib from or to ground level)

<sup>7</sup> When the external bypass is in override, the speed of the crane functions are limited to 15% of their maximum speed for movements that increase load

<sup>8</sup> Cranes equipped with boom or swing motion limiter (see [Page 3-60](#) for procedure)

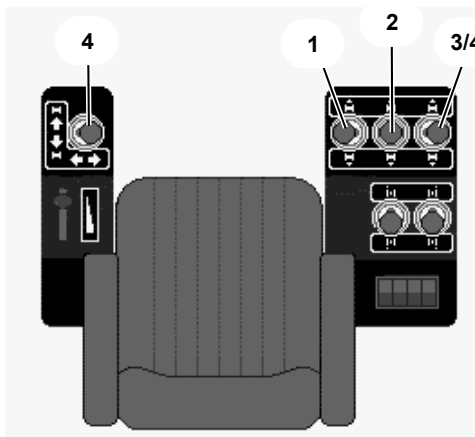
**NOTE:** Cranes meeting 2010 European requirements are equipped an RCI/RCL External Override Switch located outside the operator's cab (see Rated Capacity Indicator/Limiter Operation Manual).

14COM3-10

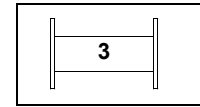
### DRUM AND HANDLE IDENTIFICATION

Left Console

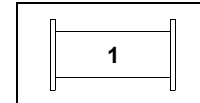
Right Console



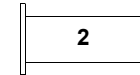
Drum No.	Description
1	Front Load Drum
2	Rear Load Drum
3	Auxiliary Load/Luffing Drum (in boom butt)
4	Boom Hoist



Boom Butt



Crane



Handle Options	HANDLE 4 Controls Drum	HANDLE 1 Controls Drum	HANDLE 2 Controls Drum	HANDLE 3/4 Controls Drum
Standard	4 - Boom Hoist	1 - Front Drum	2 - Rear Drum	3 - Auxiliary Load Drum
Luffing Jib	3 - Luffing Hoist	1 - Front Drum	2 - Rear Drum	4 - Boom Hoist

FIGURE 3-12

14001010

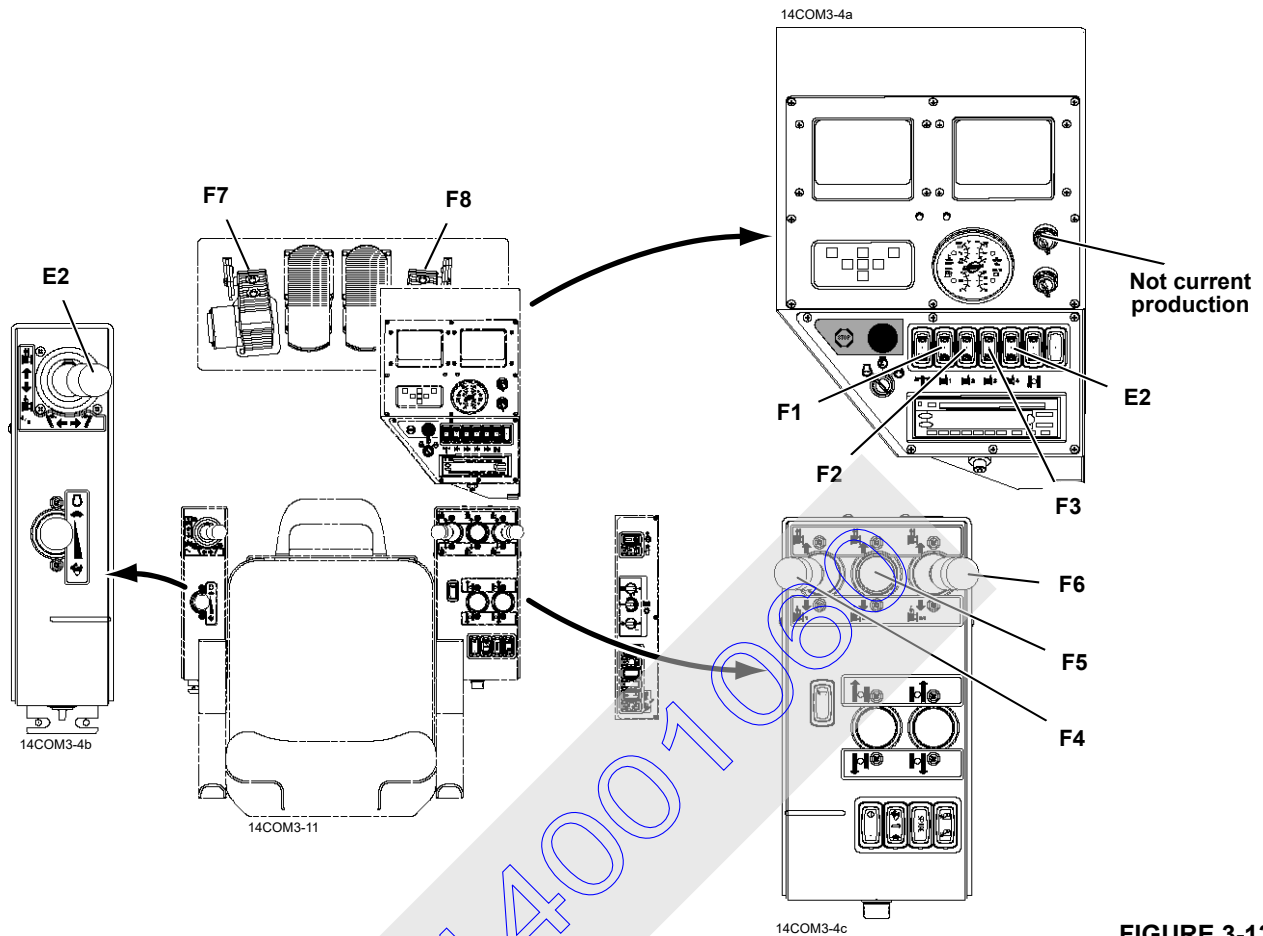


FIGURE 3-13

**E – Boom Hoist Controls**

See [Figure 3-13](#) for the drum and handle identification.

Boom hoist and swing systems are controlled by a dual-axis handle that allows both functions to be operated at the same time with one handle.

Boom hoist has a spring-applied, hydraulically-released disc brake on drum motor.

- Drum brake is released automatically when handle is moved in either direction from off
- Drum brake is applied automatically when handle is moved to off, engine is stopped (or power is lost for any reason), applicable operating limits are reached, applicable system faults occur, or selected park switch is turned on

**E1. Drum 4 (Boom Hoist) Park Switch**

Press TOP of rocker to TURN ON park switch. With park switch on, boom hoist handle is inoperable, drum brake is applied, and drum pawl is engaged.

Press BOTTOM of rocker to TURN OFF park switch. With park switch off, boom hoist handle is operable, drum brake is applied and released in conjunction with handle movement, and drum pawl is disengaged.

**E2. Drum 4 (Boom Hoist) Handle**

Pull handle BACK to RAISE boom. Drum brake releases and speed increases in relation to handle movement.

Release handle to CENTER to STOP boom. Drum brake spring applies.

Push handle FORWARD to LOWER boom. Drum brake releases and speed increases in relation to handle movement.

**NOTE:** When crane is configured with a luffing jib (optional), boom hoist handle 3/4 is the last load drum handle on right console. Luffing jib is then controlled with handle 4.



## F – Load Drum Controls

See [Figure 3-13](#) for the drum and handle identification.

Each load drum has a spring-applied, hydraulically-released disc brake on motor at one end of drum.

Additionally, if the front or rear drum has free fall, a spring-applied, hydraulically-released disc-type clutch/brake is provided on the right end of drum.

For normal operation (free fall off):

- Corresponding drum brake is released automatically when drum handle is moved in either direction from off
- Corresponding drum brake is applied automatically when drum handle is moved to off

For FREE-FALL operation:

- The disc brake (on left end of drum) is applied at all times
- The corresponding clutch/brake (on right end of drum) is spring applied when the drum handle is moved from off to hoist or lower the load with full power
- The corresponding clutch/brake is released when drum handle is moved to off. Use drum working brake to control lowering speed and to stop and hold load in position

**NOTE:** Drum brakes are applied automatically when engine is stopped (or power is lost for any reason), applicable operating limits are reached, applicable system faults occur, or drum park switch is on.

### F1. Drum 1 (Front Drum) Park Switch

### F2. Drum 2 (Rear Drum) Park Switch

### F3. Drum 3 (Auxiliary/Luffing Jib) Park Switch

Press TOP of rocker to TURN ON corresponding drum park switch. With drum park switch on, drum handle is inoperable, drum brake is applied, and (if equipped) drum pawl is engaged.

Press BOTTOM of rocker to TURN OFF drum park switch. With drum park off, drum handle is operable, drum brake is applied and released in conjunction with handle movement, and (if equipped) drum pawl is disengaged.

### F4. Drum 1 (Front Drum) Handle

### F5. Drum 2 (Rear Drum) Handle

### F6. Drum 3/4 (Auxiliary/Luffing Jib) Handle

See [Figure 3-12](#) for the drum and handle identification.

The following description is for standard operation (free fall off) If free fall is on, **corresponding drum working brake must be applied to stop load when drum handle is released to off.**

Pull handle BACK to HOIST load. Drum brake releases and speed increases in relation to handle movement.

Release handle to CENTER to STOP load. Drum brake spring applies.

Push handle FORWARD to LOWER load. Drum brake releases and speed increases in relation to handle movement.

### F7. Drum 1 (Front Drum) Working Brake Pedal

### F8. Drum 2 (Rear Drum) Working Brake Pedal

Each free fall equipped drum has a spring-applied, hydraulically-released working brake controlled by a brake pedal ([Figure 3-14](#)). When free falling a load, working brake must be used to slow down and stop the load.

The brake pedals have no function and are inoperable when operating in full power.

DEPRESS pedal to APPLY working brake in relation to pedal movement. Fully depress and latch pedal to fully apply brake.

DEPRESS heel of latch to unlatch pedal and then RELEASE pedal (ease up) to RELEASE the working brake gradually as pedal rises.

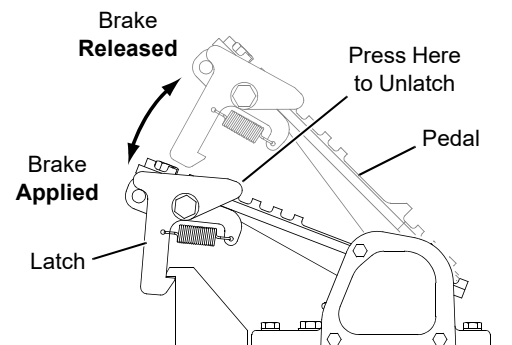


FIGURE 3-14

## G – Swing Controls

See [Figure 3-15](#) for the swing controls.

Swing drive has a spring-applied, hydraulically-released disc brake.

- Brake is released during normal operation
- Brake is applied automatically if power is lost, when swing holding brake switch is enabled, and when drum park switch is turned on

### G1. Swing Park Switch

Press TOP of rocker to TURN ON swing park switch. With park switch on, swing handle is inoperable and swing brake is applied.

Press BOTTOM of rocker to TURN OFF swing park switch. With park switch off, swing handle is operable and swing brake is released.

### G2. Swing Handle

- Dual-axis handle allows boom hoist and swing to be operated at the same time with one handle
- Swing/travel alarm will beep to warn personnel when rotating bed is swung

Move handle to LEFT to SWING LEFT. Swing speed increases in relation to handle movement.

Release handle to CENTER to STOP. Swing speed decreases to off and rotating bed slows to a stop. Move

handle in opposite swing direction to stop swing motion faster.

Move handle to RIGHT to SWING RIGHT. Swing speed increases in relation to handle movement.

### G3. Swing Holding Brake Switch

---

#### CAUTION

##### Swing Drive/Boom Damage!

Do not apply swing holding brake or turn on swing park switch while swinging; brake will bring rotating bed to an abrupt stop. This action could cause damage to boom from side loading or damage to swing drive from shock loading. Bring rotating bed to smooth stop with swing handle and then apply swing holding brake or turn on swing park switch.

---

Use swing holding brake switch (on side of handle) to hold the rotating bed in position for short periods of time during operating cycle. Swing handle will be inoperable while swing holding brake button is pressed.

PRESS button to APPLY swing holding brake.

RELEASE button to RELEASE swing holding brake.

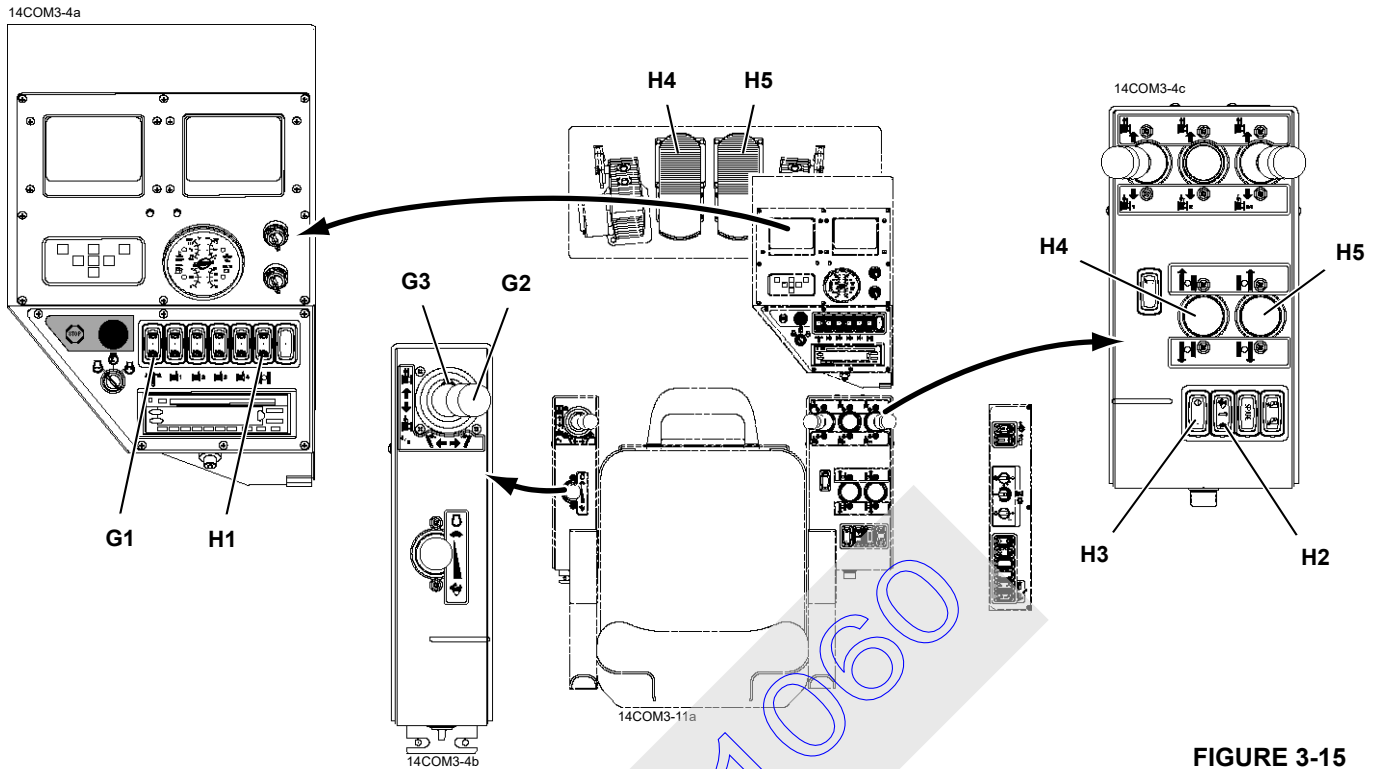


FIGURE 3-15

**H – Travel Controls**

See [Figure 3-15](#) for the travel controls.

Crawlers have spring-applied, hydraulically-released disc brakes.

- Both crawler brakes release when either crawler handle is moved in either direction from off
- Both crawler brakes apply when both crawler handles are moved to off
- Both crawler brakes apply to hold crane in position if power is lost for any reason

**H1. Travel Park Switch**

Press TOP of rocker to TURN ON travel park switch. With travel park switch on, travel handles are inoperable and brakes are applied.

Press BOTTOM of rocker to TURN OFF travel park switch. With travel park switch off, travel handles are operable and brakes are applied and released in conjunction with handle movement.

**H2. Travel Speed Selector**

Press TOP of rocker to operate travel motors in HIGH speed. High speed operation provides maximum available travel speed for traveling long distances.

Press BOTTOM end of rocker to operate travel motors in LOW speed. Low speed operation provides smooth starts and stops and more precise control of travel motors than high speed.

In low speed, travel motors operate at approximately 1/3 the speed of high speed.

**NOTE:** It is all right to change travel speed while traveling:

Travel motors will shift immediately from high to low when low speed is selected.

Travel motors will not shift from low to high when high speed is selected until:

- Engine speed is at high idle
- Hydraulic pressure is low enough to allow motors to shift from low to high speed

**H3. Travel Cruise Selector**

Travel cruise selector allows crawlers to be operated in either direction at a selected speed without the operator's hand on crawler handles.

Move both crawler handles in either direction from off to select desired speed and direction of travel. Press TOP of rocker to TURN ON travel cruise. Release handles to off. Crawlers continue to travel at selected speed and direction.

Slightly move either crawler handle in the opposite direction or press BOTTOM of rocker to TURN OFF travel cruise.

#### H4. Left Crawler Handle or Pedal

#### H5. Right Crawler Handle or Pedal

The following directions of travel are with **front of rotating bed and front of carbody facing same direction.**

- Operator's cab is at front of rotating bed
- Carbody and crawler control valve is at front of carbody. If front of rotating bed and front of carbody face in opposite directions, crane will travel in the direction opposite handle movement

Push handle FORWARD or depress front of pedal to travel FORWARD. Brakes release and speed increases in relation to handle or pedal movement.

Release handle to CENTER to STOP traveling. Brakes spring apply.

Pull handle BACK or depress rear of pedal to travel in REVERSE. Brakes release and speed increases in relation to handle or pedal movement.

Swing/travel alarm beeps to warn personnel when crane is traveled.

## LIMIT DEVICES

See [Table 3-2](#) to determine which limit bypass switch bypasses a given limit.

### 1. Boom Maximum Up Limit

Automatically stops boom when it is raised to either of the following maximum angles:

- 84° for boom with or without fixed jib (without luffing jib)
- 88.5° for boom with luffing jib

Boom can be lowered after the limit is contacted.



#### WARNING

##### Falling Boom/Jib Hazard!

Do not raise boom above specified maximum angle. Boom and jib could be pulled over backwards.

### 2. Boom Down Limit

Automatically stops boom when it is lowered to a preset minimum angle (usually 0°).

Boom can be raised after the limit is contacted.



#### WARNING

##### Falling Boom Hazard!

When lowering boom below down limit, do so slowly with extreme caution. Do not lower boom to point where less than three full wraps of wire rope are on boom hoist drum; wire rope could be pulled out of drums allowing boom to fall.

The appropriate limit bypass switch must be turned to the bypass position before the boom can be lowered below the limit.

### 3. Block-Up Limit



#### WARNING

##### Two-Blocking Hazard!

If it is necessary to hoist a load above block-up limit, do so slowly with extreme caution to prevent two-blocking.

Do not hoist load above minimum block clearance given in Range Diagram (see Capacity Chart Manual).

Do not use limit bypass switch to lower boom or luffing jib after block-up limit is contacted; two-blocking could occur, causing load to fall.

Automatically stops boom or luffing hoist from lowering and load drums from hoisting if the load contacts a block-up limit switch.

The load on corresponding drum can be lowered and boom or luffing jib can be raised, if they are not at the maximum up limit, after a block-up limit switch is contacted.

The appropriate limit bypass switch must be turned to the bypass position before a load can be hoisted above the limit.

#### 4. Luffing Jib Up Limit



#### WARNING

##### Falling Boom/Jib Hazard!

To prevent boom and luffing jib from being pulled over backwards:

- Proceed slowly when operating above JIB MAXIMUM UP 1 angle
- Do not raise luffing jib above JIB MAXIMUM UP 2 limit

Two luffing jib up limits stops are provided:

- **JIB MAXIMUM UP 1** (max working angle): automatically stops the luffing jib when the boom to jib angle is 168°

The appropriate limit bypass switch must be turned to the bypass position to allow the jib to be raised an additional 3° to JIB MAXIMUM UP 2 limit

- **JIB MAXIMUM UP 2** (max angle): automatically stops the luffing jib when the boom to jib angle is 171°

This limit **cannot** be bypassed for cranes meeting 2010 European requirements (CE). See [Table 3-3](#) for bypassable limit identification.

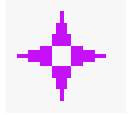
The luffing jib can be lowered after either limit is contacted.

**NOTE:** For current production cranes meeting 2010 European Requirements the luffing jib cannot be lowered after JIB MAXIMUM UP 2 limit is contacted until the limit switch is reset.

When the limit is contacted, operation will stop and the jib up prompt (shown to right) will appear on the main display.



Once the prompt appears, release the control handle to off and press the confirm button (shown to right) to reset the limit switch. The luffing jib can then be lowered.



#### 5. Luffing Jib Down Limit



#### WARNING

##### Falling Boom/Jib Hazard!

Do not lower luffing jib below maximum down limit 2. Structural damage will result, possibly causing boom and luffing jib to collapse.

Two luffing jib down limits stops are provided:

- **JIB DOWN 1:** turns on fault 50 alarm to alert operator that jib is near maximum down limit 2 (occurs when boom to jib angle is 60° regardless of jib type — layout or fold-under)
- **JIB MAXIMUM DOWN 2:** automatically stops the luffing jib when the boom to jib angle is:
  - 57° for layout luffing jib
  - 10° for fold-under luffing jib

This limit **cannot** be bypassed for cranes meeting 2010 European requirements (CE).

Non-CE machines can be bypassed if handle returns to neutral while bypass is held.

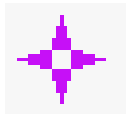
The luffing jib can be raised after the limit is contacted.

**NOTE:** For current production cranes meeting 2010 European Requirements the luffing jib cannot be raised after JIB MAXIMUM DOWN 2 limit is contacted until the limit switch is reset.

When the limit is contacted, operation will stop and the jib down prompt (shown to right) will appear on the main display.



Once the prompt appears, release the control handle to off and press the confirm button (shown to right) to reset the limit switch. The luffing jib can then be raised.



### 6. Maximum Bail Limit

Automatically stops corresponding drum from hoisting when there is a preset maximum number of wire rope layers on the drum.

Load can be lowered after the limit is contacted.

**! WARNING**  
**Falling Load Hazard!**

Do not exceed maximum allowable spooling capacity given in Wire Rope Specifications Chart in operator's cab. Wire Rope could jump off drum allowing load to fall.

The appropriate limit bypass switch must be turned to the bypass position before the load can be hoisted above the limit.

### 7. Minimum Bail Limit

Automatically stops corresponding drum from lowering when there are three wraps of wire rope remaining on the drum.

Load can be raised after the limit is contacted.

**! WARNING**  
**Falling Load Hazard!**

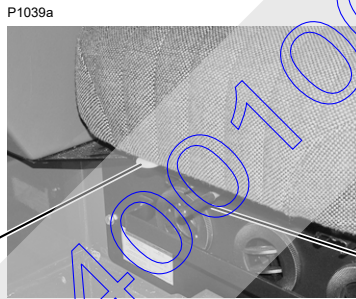
When lowering load below minimum bail limit, do so slowly with extreme caution. Do not lower load to point where less than three full wraps of wire rope are on drum; wire rope could be pulled out of drum allowing load to fall.

The appropriate limit bypass switch must be turned to the bypass position before the load can be lowered below the limit.

### SEAT CONTROLS

**SEAT FORE-AFT (seat only)**

- Push lever to left to unlock
- Use body weight to slide seat to desired position
- Release lever and make sure it is latched to lock seat in position



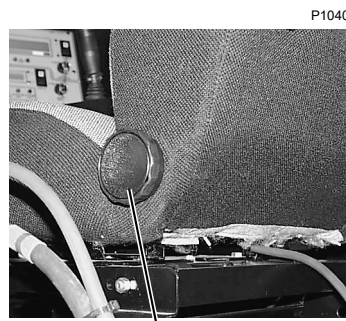
**SEAT FORE-AFT (seat and consoles)**

- Push lever to left to unlock
- Use body weight to slide seat and consoles to desired position
- Release lever and make sure it is latched to lock seat and consoles in position



**ARMREST**

- Open zipper at end of armrest
- Turn bolt clockwise to raise arm rest or counterclockwise to lower armrest
- Tighten jam nut and close zipper



**BACKREST**

- Turn knob to raise and lower backrest to desired position

**FIGURE 3-16**



## PREPARING CRANE FOR OPERATION



### WARNING

#### Read Capacity Charts!

Do not attempt to operate crane without first reading and understanding capacity charts.

Crane must be rigged and operated according to instructions given in capacity charts and rigging guides.

Unless otherwise specified in capacity charts, all crane operations must be performed with crane level to within one 1% of grade in all directions — 1 ft in 100 ft (0.3 m in 30 m); otherwise, crane could tip.

Do not operate crane, to include raising boom from ground level, if wind exceeds limits given in Capacity Charts. Contact your local weather station for wind velocity.

Failing to comply with Capacity Chart requirements can result in tipping or structural failure of boom or luffing jib.

#### Moving Load Hazard!

Operator shall select proper crane capacity chart before operating.

Unexpected drum motion or improper limit responses can result if wrong capacity chart is selected.

Limit bypass switches must be in enable position (on) and all limits with which crane is equipped must be operational before operating crane.

#### Avoid injuring personnel in operating area!

Sound horn to alert personnel that operation is about to begin.

#### Moving Machinery Hazard!

To avoid injuring personnel or damaging crane and property:

- Do not start engine if warning or out-of-order sign is present at start controls
- Check that all controls are off so crane and load do not move when engine is started
- Check that all personnel are clear of crane before starting engine. **Sound horn to alert personnel**

### CAUTION

#### Avoid Machinery Damage!

Before operating crane at start of each shift, perform preventive maintenance checks and lubrication requirements listed in Sections 5 and 6 of this manual.

Adjust operator's seat as shown in [Figure 3-16](#).

## OPERATION

### Engine Startup

Read and understand starting instructions in Engine Operation and Maintenance Manual provided with crane.

1. If used, unplug or turn off engine block heater, engine oil pan heater, hydraulic tank heaters and any other crane heaters.

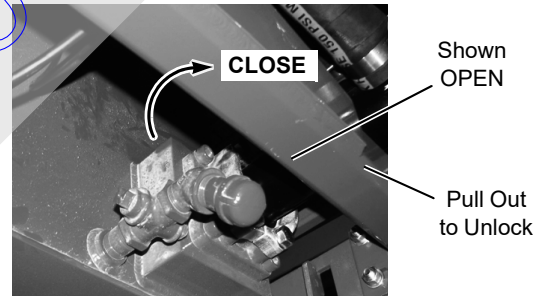
**NOTE:** Manitowoc recommends using heaters (engine, hydraulic tank, etc.) to aid start-up when ambient temperature will be 32°F (0°C) and below.

### CAUTION

#### Pump Damage!

Do not start engine until hydraulic tank shutoff valve is open; otherwise, pumps could cavitate and be damaged.

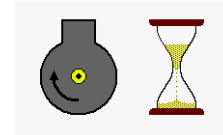
2. Open hydraulic tank shutoff valve at rear of hydraulic tank (see [Figure 3-17](#)).



Front of Hydraulic Tank

FIGURE 3-17

3. Turn ignition switch to RUN position. **WAIT TO START** icon will appear on digital display indicating that pre-heater is warming engine's air intake. Don't try to start engine until icon disappears from display (4-5 seconds).



**NOTE:** All indicator lights, operating limit buzzer, and system fault beeper should come on for 2 to 3 seconds when ignition switch is in RUN position; if not, replace defective parts.

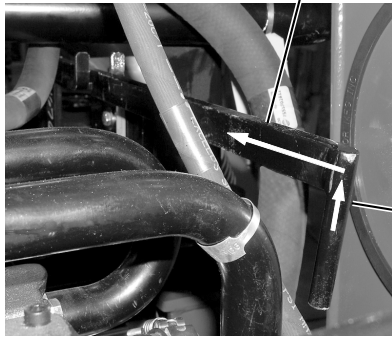
4. Turn ignition switch to START position when **WAIT TO START** icon disappears.

**NOTE:** If engine does not start, check to see if the engine emergency stop switch or the remote control stop switch is depressed. If so, pull it out.



- If necessary in cold weather, disengage engine clutch as shown in [Figure 3-18](#). This step will disconnect pumps from engine and aid in cold weather startup.

Engine Clutch Handle  
Shown in Disengaged Position  
(lift handle UP, pull OUT, and latch in bracket)



P2374  
Left Side Enclosure at Front of Hydraulic Tank

Lift Handle UP and Push IN to Engage

FIGURE 3-18

**CAUTION**

**Avoid Engine Clutch Damage!**

Observe following precautions for engine clutch:

- **Decrease engine speed to idle** before engaging or disengaging clutch
- Do not run engine longer than twenty minutes with clutch disengaged
- Disengage and engage clutch several times monthly with engine running

- Turn ignition switch to START.

**CAUTION**

**Starter Motor Damage!**

If engine does not start after 30 seconds of cranking, wait a few minutes so starter motor cools before trying again.

- Increase engine speed as necessary to keep engine running after it starts.

Reminder: Engine speed cannot be increased while the following faults are on. Engine speed can be reduced, but cannot be increased again until the faults are off. See [Page 3-53](#) for fault identification.

- Fault 40, High Vacuum
- Fault 61, Dirty Return Filter

- If engine clutch is disengaged, decrease engine speed to low idle and engage engine clutch within 20 minutes after starting engine.

**NOTE:** Engine clutch may be engaged when temperature of hydraulic oil is above 0°F (-18°C).

Hydraulic tank heaters are designed to keep the temperature of hydraulic oil in the tank at a minimum of 0°F (-18°C).

- Run engine at low idle until hydraulic oil temperature is at least 60°F (16°C).

**NOTE:** It is normal for engine and crane faults to appear when engine is started. Faults should go away as soon as engine oil pressure and hydraulic oil temperature rise to normal (if no other faults exist).

**CAUTION**

**Machinery Damage!**

Do not operate crane when engine and crane faults exist. If faults do not go away soon after engine is started or come on during operation, immediately proceed as follows:

- Determine fault on Main display, Information screen
- Land loads, if possible, and park all functions
- Move all control handles to off
- Stop engine
- Correct cause of fault

**Mast Assist Damage!**

Prevent damage to mast assist arms and cylinders during cold weather:

- Do not attempt to lower live mast with boom hoist until temperature of hydraulic oil is 60°F (16°C)
- Once oil is at specified temperature, fully extend and retract mast assist cylinders twice to fill cylinders with warm oil
- Cylinders and arms will bend under weight of mast if this precaution is not taken

**Machinery Damage!**

- Continuous operation with hydraulic oil temperature above 180°F (82°C) can result in damage to hydraulic components. Troubleshoot hydraulic system if oil temperature exceeds 180°F (82°C)

- After engine is started, cab seat with handles appears as shown in [Figure 3-19](#). Use display buttons to select the crane configuration, then press Confirm button to select configuration.

T Appears Here when Tandem Drum Mode is Turned ON

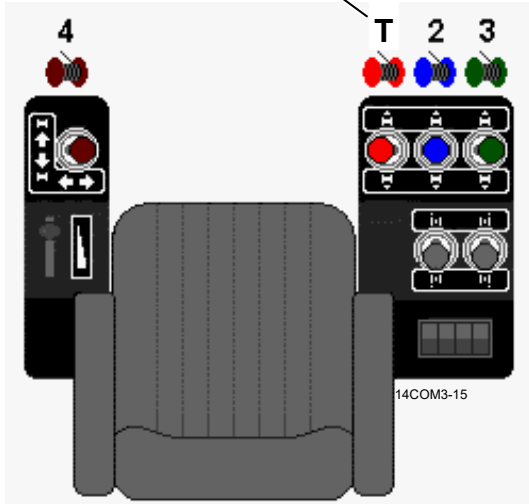
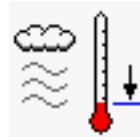


FIGURE 3-19

- When crane configuration is selected, the information screen appears with engine data box on right side and previously selected items on the left side as shown in [Figure 3-41](#).
- Select crane configuration and capacity charts on Rated Capacity Indicator/Limiter display, Configuration screen. Load drums and hoist drums are inoperable until this step is performed.

- If equipped, an optional air temperature sensor monitors ambient temperature in the left side enclosure ([Figure 3-20](#)).



When ambient air temperature of  $-22^{\circ}\text{F}$  ( $-30^{\circ}\text{C}$ ) is reached, fault message #45 appears on the fault screen.

The crane's software program will not allow booming down or hoisting up until ambient temperature is above  $-22^{\circ}\text{F}$  ( $-30^{\circ}\text{C}$ ).

If the electric cable is disconnected from the temperature sensor, a terminator receptacle must be connected to the cable to bypass the sensor; otherwise the fault message above will appear on the fault screen.

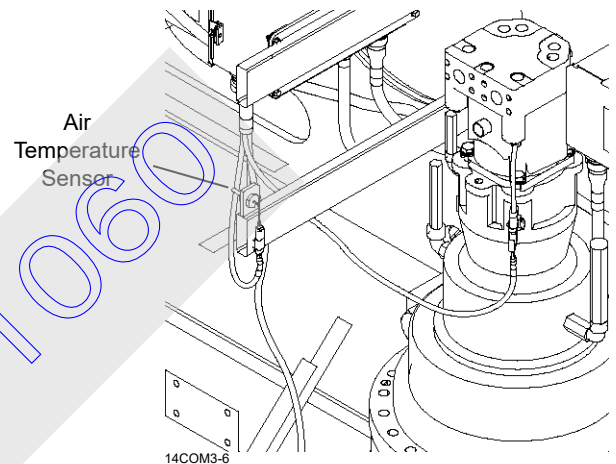


FIGURE 3-20

## Boom Hoist Operation

See [Figure 3-21](#) for the boom hoist operation.

In standard configuration boom hoist handle is on the left console. When crane is configured with a luffing jib, boom hoist handle is the last load drum handle 3/4 on right console.

### CAUTION

#### Avoid Rigging Damage!

Check that boom hoist wire rope is reeved through all sheaves and spooled properly onto drum before raising boom from ground.

- See Boom Rigging Drawing in Section 4 for wire rope and reeving specifications
- See Wire Rope Installation in Section 4 for instructions on attaching wire rope to boom

1. Select crane configuration and capacity charts on Rated Capacity Indicator/Limiter display, Configuration screen.
2. Turn off Drum 4 park switch. Drum 4 pawl disengages from drum when park switch is moved to off.

### CAUTION

#### Avoid Boom or Jib Damage!

Do not turn on drum park switch while raising or lowering boom; brake will bring boom to an abrupt stop. This action could cause shock load damage to boom and jib. Bring boom to a smooth stop with handle and then turn on drum park switch.

3. Increase engine speed to desired rpm with hand throttle. Depress foot throttle to momentarily increase engine speed when more power is required.
4. See [Figure 3-21](#). Push boom hoist handle FORWARD from off to LOWER boom or pull handle BACK from off to RAISE boom.



### WARNING

#### Avoid Two-Blocking Hazard!

Pay out load lines while lowering boom. Load may contact boom point or jib point sheaves if this step is not taken. Wire rope or other parts could break allowing load to fall.

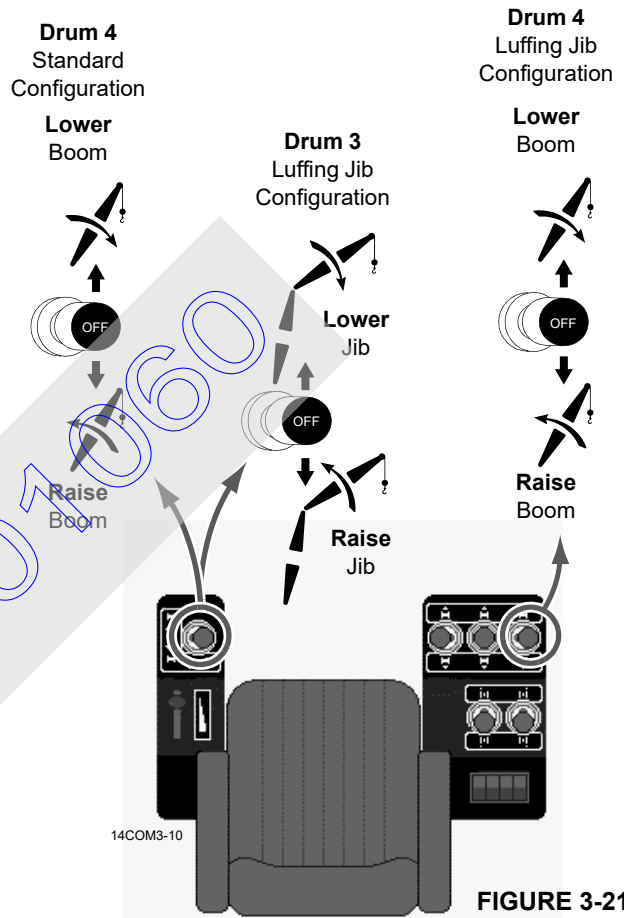


FIGURE 3-21

5. As boom nears desired angle, slowly move handle toward off to decrease speed. Then move handle to off to stop boom and hold it in position and brake will apply.

**NOTE:** Besides a boom up limit, a physical boom stop cushions boom raising between approximately 77.6° and maximum angle. Boom stop also provides a physical stop at 89.5°.

6. Turn on park switch if boom angle will not be changed. Drum 4 pawl engages into drum when park switch is moved to on.

**CAUTION****Avoid Rigging Damage!**

When lowering boom to ground:

- If equipped, disconnect fixed jib stop before jib point contacts ground
- If equipped, remove upper boom point before upper point contacts ground
- If equipped, disengage luffing jib stop at specified boom to luffing jib angle (see Luffing Jib Rigging Guide)

**Luffing Hoist Operation**

See [Figure 3-21](#) for the Luffing hoist operation.

When crane is configured with a luffing jib (Drum 3), multi-function handle on left console controls luffing jib drum.

**WARNING****Avoid Death or Serious Injury!**

Read and understand instructions in Luffing Jib Rigging Guide before attempting to raise or lower luffing jib from or to ground.

Use extreme care when operating luffing hoist and boom hoist at same time. Maximum or minimum operating radius will be reached quickly when operating both hoists at same time.

**CAUTION****Avoid Rigging Damage!**

Check that luffing hoist wire rope is reeved through all sheaves and spooled properly onto Drum 3 before raising boom and jib from ground.

- See Jib Rigging Drawing in Luffing Jib Operator Manual for wire rope and reeving specifications
- See Wire Rope Installation in Section 4 of this manual for instructions on attaching wire rope to luffing hoist drum

1. Select luffing jib configuration and capacity charts on Rated Capacity Indicator/Limiter display, Configuration screen.
2. Turn off Drum 3 park switch. Drum 3 pawl disengages from drum when park switch is moved from off.
3. Turn on travel park switch when operating drum 3.

**CAUTION****Avoid Boom or Luffing Jib Damage!**

Do not turn on Drum 3 park switch while raising or lower luffing jib; brake will bring luffing jib to an abrupt stop. This action could cause shock load damage to boom and jib. Bring luffing jib to smooth stop with control handle and then turn on Drum 3 park switch.

4. Increase engine speed to desired rpm with hand throttle. Depress foot throttle to momentarily increase engine speed when more power is required.
5. See [Figure 3-18](#). Push luffing hoist handle 4 on left console FORWARD from off to LOWER luffing jib or pull handle BACK from off to RAISE luffing jib.

**WARNING****Avoid Two-Blocking Hazard!**

Pay out load lines while lowering luffing jib. Load may contact luffing jib point sheaves if this step is not taken. Wire rope or other parts could break allowing load to fall.

6. As luffing jib nears desired angle, slowly move luffing hoist handle toward off to decrease speed. Then move handle to off to stop luffing jib and hold it in position and brake will apply.
7. Turn on Drum 3 park switch if luffing jib angle will not be changed. Drum 3 pawl engages into drum when park switch is moved to on.

**CAUTION****Avoid Luffing Jib Damage!**

When lowering boom and luffing jib to ground, disengage luffing jib stop at specified boom to luffing jib angle (see Luffing Jib Rigging Guide).

## Swing Operation

See [Figure 3-22](#) for the swing operation.



### WARNING

#### Tipping Hazard!

Prevent crane from tipping; adhere to any swing limitations given in capacity charts.



### DANGER!

#### Moving Crane Hazard!

Counterweights can strike personnel in area of swing path! Warn personnel to stay clear of swing path. Sound horn prior to swinging.

1. Turn off swing park switch.

### CAUTION

#### Avoid Boom/Swing Drive Damage!

Do not apply swing holding brake or turn on swing park switch while swinging; brake will bring rotating bed to an abrupt stop. This action could cause damage to boom and luffing jib from side loading or damage to swing drive from shock loading. Bring rotating bed to a smooth stop with swing handle and then apply swing holding brake or turn on swing park switch.

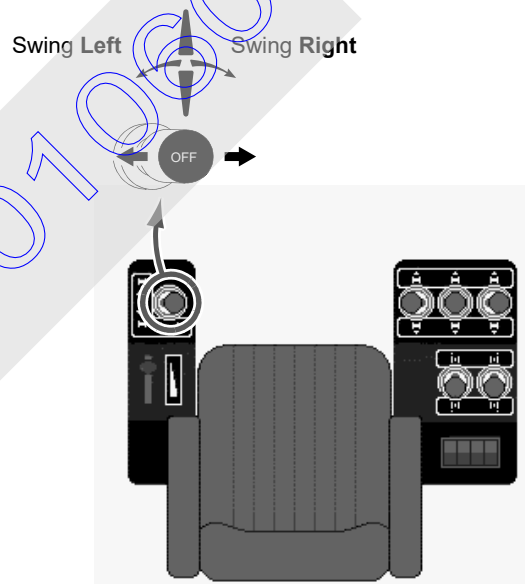
2. Increase engine speed to desired rpm with hand throttle. Press foot throttle to momentarily increase engine speed when more power is required.
3. See [Figure 3-22](#). Push swing handle to LEFT from off to SWING LEFT or pull handle to RIGHT from off to SWING RIGHT.
4. Start swing motion with a smooth acceleration. Continue handle motion to swing at desired speed.

**NOTE:** Adjust swing speed and torque, as required, in the Swing Function Mode screen.

If equipped with the optional swing limit assembly:

- Program the desired automatic swing stops in the Swing Function Mode screen
  - Adjust the mechanical swing stops (limit switches). See Section 6 of Service Manual for procedure
5. Stop swinging by releasing swing handle to off. Swing speed will decrease to off and rotating bed will coast to a stop. If a faster stop is desired, move swing handle past off to opposite swing direction.
  6. Once rotating bed stops, apply swing holding brake to hold rotating bed in position for short periods during operating cycle.

To hold rotating bed in position for long periods, turn on swing park switch.



14COM3-10

FIGURE 3-22

### Load Drum Operation

See [Figure 3-23](#) for the load drum operation.

**NOTE:** See [Figure 3-12](#) for the drum identification.



#### WARNING

##### Falling Load Hazard!

Prevent load on unused drums from falling. Turn on drum park switch for drums not in use.

#### Liftcrane Operation — (With Free Fall Off)

1. Select crane without free fall configuration and capacity charts on Rated Capacity Indicator/Limiter display, Configuration screen.

**NOTE:** On free fall equipped cranes, load drum working brake pedals have no function and are inoperable while operating drums in full power.

2. Turn off drum park switch (Drum 1, 2 or 3) for drum to be operated.
3. Turn on travel park switch when operating drum 3.

#### CAUTION

##### Avoid Boom or Luffing Jib Damage!

Do not turn on drum park switch while raising or lowering load; brake will bring load to an abrupt stop. This action could cause shock load damage to boom, luffing jib, and load line. Bring load to a smooth stop with drum handle and then turn on drum park switch.

4. Increase engine speed to desired rpm with hand throttle. Depress foot throttle to momentarily increase engine speed when more power is required.
5. Pull drum handle (Drum 1, 2, or 3) BACK from off to RAISE load or push handle FORWARD from off to LOWER load.

6. As load nears desired position, slowly move drum handle toward off to slow down load. Then release handle to off to stop load and hold it in position and drum brake will apply.
7. Turn on Drum 1, 2, or 3 park switch when selected load drum is not being used.

14COM3-10

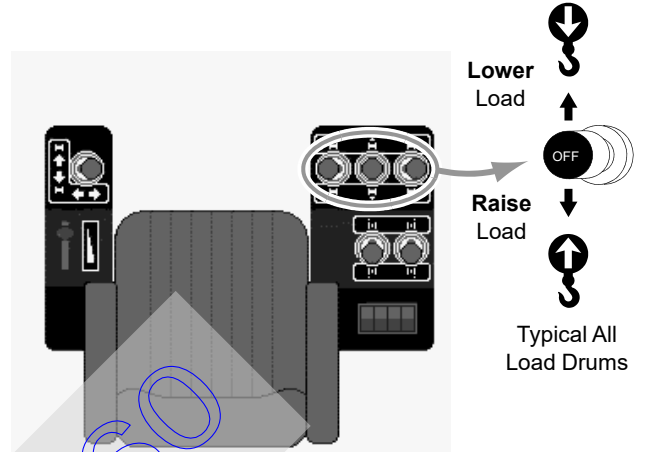


FIGURE 3-23

#### Liftcrane Operation — Free Fall



#### WARNING

##### Falling Load Hazard!

To prevent load from falling when free fall is selected for either drum, follow steps in sequence given below.

1. To turn free fall **on**:
  - a. Move Drum 1 or Drum 2 free fall selector handle **counter-clockwise** to **on** position as shown in [Figure 3-24](#). Free fall selector handles are located in right side enclosure.



14COM3-93

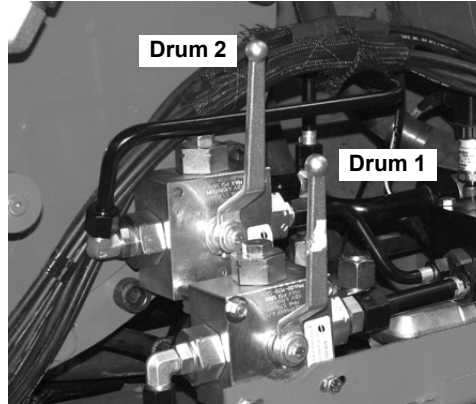
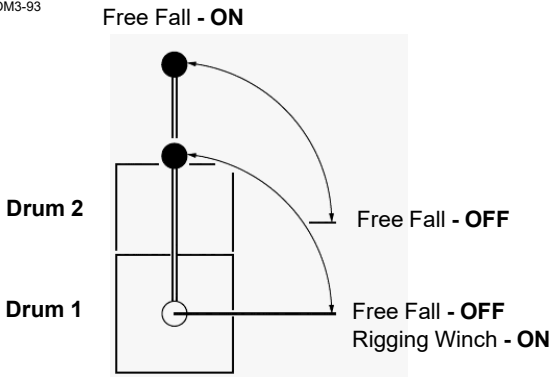


FIGURE 3-24

- b. Latch down free fall brake pedals on floor of operator's cab.
- c. Turn drum free fall **on** in Drum Functions Screen shown in [Figure 3-25](#).

- 2. Increase engine speed to desired rpm with hand throttle. Depress foot throttle to momentarily increase engine speed when more power is required.
- 3. See [Figure 3-24](#). Pull drum handle (Drum 1 or 2) BACK from off (release working brake) to RAISE load or push handle FORWARD from off to LOWER load.
- 4. As load nears desired position, slowly move drum handle toward off to slow down load. **Then fully apply drum working brake to stop load and release drum handle to off.**

**CAUTION**

**Avoid Boom or Luffing jib Damage!**

Do not turn on drum park while raising or lowering load; brake will bring load to an abrupt stop. This action could cause shock load damage to boom, luffing jib, and load line. Bring load to a smooth stop with drum handle and then turn on drum park.



**WARNING**

**Falling Load Hazard!**

When operating in free fall, load will lower uncontrolled if drum working brake is not applied when drum handle is released to off.

Be ready to apply drum working brake so lowering speed can be controlled and load can be stopped immediately when necessary.

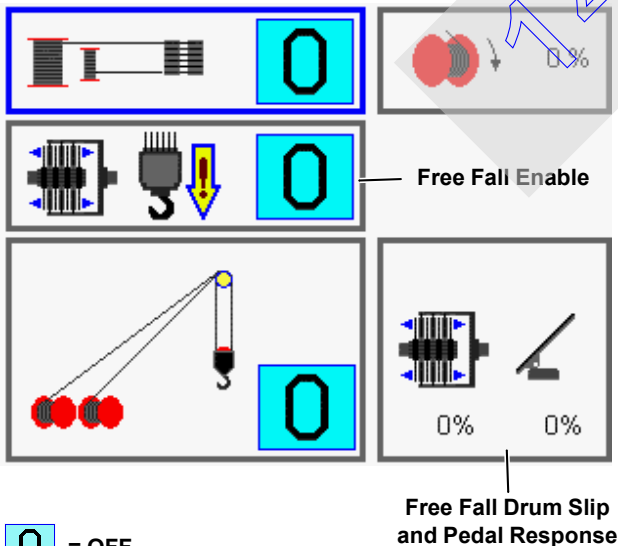


FIGURE 3-25

**NOTE:** The drum free-fall icon for either or both drums will flash.

- 5. Load can be lowered in one of two ways — with drum working brake or with hydraulic power:
  - a. To lower load with DRUM WORKING BRAKE, leave drum handle in off and release drum working brake to lower load at desired speed.
 

As load nears desired position, slowly apply drum working brake to slow down load. Then fully apply brake to stop load and hold it in position.

**NOTE:** Adjust drum slip and pedal response, as required, in the Drum Functions Screen ([Figure 3-25](#)). See Drum Functions on [Page 3-59](#).

- b. To lower load with HYDRAULIC POWER, push drum handle forward from off and release drum



working brake. Lowering speed is controlled by handle movement.

As load nears desired position, slowly move drum handle toward off to slow down load. **Then fully apply drum working brake to stop load and hold it in position.**

### CAUTION

#### Avoid Clutch/Motor Damage!

Do not move drum handle in either direction from off while free falling a load. Serious damage to drum clutch and motor could result. Stop load with drum working brake and then move drum handle in desired direction.

6. If load will be suspended for any length of time, latch working brake pedal in applied position and turn on drum park.
7. To turn free fall **off**:
  - a. Latch down free fall brake pedals on floor of operator's cab.
  - b. Turn drum free fall **off** in Drum Functions Screen for each drum, as shown in [Figure 3-25](#).
  - c. Move Drum 1 or Drum 2 free fall selector handle **clockwise** to **off** position as shown in [Figure 3-24](#).

#### Clamshell Operation

##### Preparing For Clam Operation:

1. Select desired Clamshell Capacity Chart on RCL display to turn on clamshell mode.
2. Turn off drum park for both drums.
3. Set engine speed at desired rpm.
4. Clam closing pressure is set automatically.

##### Clamshell Operation In Full-Power

Perform Preparing for Clam Operation steps. Then proceed as follows:

##### CLOSING BUCKET (Digging)

1. Lower bucket into digging area.
2. Pull back closing line handle to close bucket. The holding line will pay out automatically allowing the bucket to dig in as it closes.
3. Release closing line handle to off when bucket is closed fully.

**NOTE:** Watch the closing line when digging in a blind area. The bucket is closed when the closing line stops moving.

##### RAISING BUCKET

1. Pull holding line handle back to raise bucket at desired speed.
2. Swing to dumping area as bucket rises.
3. Release holding line handle to off when bucket is at desired height.

##### DUMPING BUCKET

1. Push closing line handle forward to dump bucket at desired speed.
2. Release closing line handle to off as soon as bucket is empty and fully open.

Use care not to slacken closing line while dumping. Any slack in closing line will have to be taken out while digging. This action will slow down clam cycle.

##### LOWERING BUCKET

1. Push holding line handle forward to lower bucket at desired speed.
2. Control lowering speed by slowly moving holding line handle toward off.

**NOTE:** Lowering speed is controlled by handle movement. It is not necessary to apply the working brakes to slow down the bucket in full-power clamshell operation.

3. Swing back to digging area as bucket lowers.
4. Stop swinging when bucket lands in digging area.
5. Bucket will stop lowering automatically when it contacts ground.
6. Release holding line handle to off.
7. Repeat clam cycle.

**NOTE:** Clamshell operation can also be performed with the load drums in the Free Fall configuration. Use the working brakes to control the bucket when the handles are in the off position. If the holding line is operated in free fall, the closing line must also be operated in free fall; otherwise, the closing line will not keep up with the holding line and the bucket will close while lowering.

## Travel Operation



### WARNING

#### Tipping Hazard!

Travel surface must be firm and uniformly supporting.

For **traveling with load**, grade must not exceed 1% in any direction.

For **traveling without load**, grade in direction of travel must not exceed 30%; grade from side to side must not exceed 2%, measured at boom hinge pins. For all travel on grades, see Maximum Allowable Travel Specifications Chart in Capacity Chart Manual.

Failing to comply with above specifications can result in tipping.

#### Moving Crane Hazard!

Know position of rotating bed with relation to front of carbody before traveling. An accident can result if crane travels opposite of intended direction.

#### Flying Object Hazard!

Excessive dirt build-up at tumbler and front roller ends of crawlers can result in excessive tension in tread connectors. Tread connectors can break if over tensioned, causing treads to fly apart unexpectedly with dangerous force.

### CAUTION

#### Crawler Damage!

Avoid damage to crawler components (treads, rollers, frames)!

Use care to prevent dirt from piling up at tumbler and front roller ends of crawlers when turning on soft surfaces:

- Bring crawlers to a complete stop before changing travel direction
- Turn a few degrees. Then slowly travel forward or reverse so dirt falls away from crawlers. Continue this procedure until desired turn has been made
- Avoid sharp turns ([Figure 3-27](#)) if possible
- Make gradual turns ([Figure 3-28](#)) or counter-rotate ([Figure 3-29](#)) whenever possible so both crawlers are always powered
- Clean crawlers often
- Keep crawler treads properly adjusted

### CAUTION

#### Boom Damage!

Avoid shock loading boom and rigging!

- Perform all travel functions — starting, turning, stopping — slowly and smoothly

#### 1. Before traveling:

- a. Plan travel route. It must be free of ground and overhead constructions.
- b. Check crawlers for proper adjustment.
- c. Warn personnel to stand clear of travel area. **Do not travel without a signal person.**

#### 2. Turn off travel park switch.

#### 3. Turn on drum 3 park switch when operating travel.

#### 4. Position boom at or above boom angle given on capacity chart when **traveling with load**.

#### 5. Travel with boom in-line with crawlers except when swinging is necessary while traveling. Travel with boom facing direction of travel.

#### 6. For **traveling with load**, carry load as close to ground as possible; stabilize load with taglines.

For **traveling without load**, carry load block and weight ball low enough that they cannot swing into boom or jib. If desired, tie off load block at front of rotating bed.

#### 7. Increase engine speed to desired rpm with hand throttle. Depress foot throttle to momentarily increase engine speed when more power is required.

#### 8. Select desired travel speed, low or high.

**NOTE:** The following directions of travel are with **front of rotating bed and front of carbody facing same direction**.

- Operator's cab is at front of rotating bed
- Carbody/crawler control valve is at front of carbody

If front of the rotating bed and front of carbody face in opposite directions, crane will travel in the direction opposite of handle movement.

- 9. To TRAVEL STRAIGHT (Figure 3-26), move both crawler handles same amount in desired direction from off.

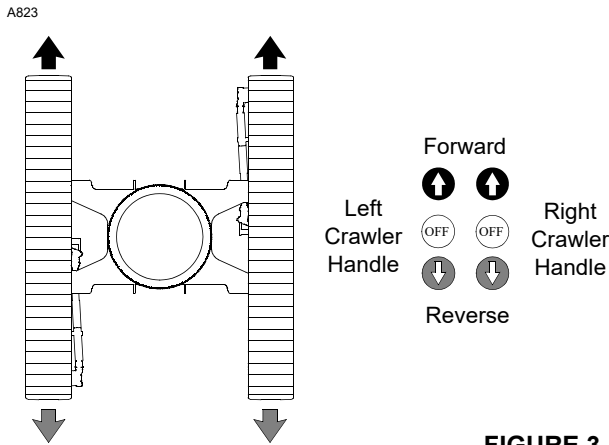


FIGURE 3-26

- 10. To make a SHARP LEFT TURN (Figure 3-27), move right crawler handle to front from off and leave left crawler handle in off; crane will pivot about left crawler.
- 11. To make a SHARP RIGHT TURN, reverse step 9.

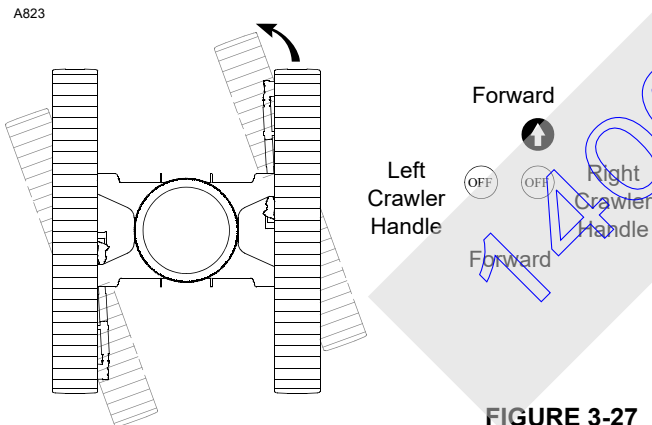


FIGURE 3-27

- 12. To make a GRADUAL LEFT TURN (Figure 3-28), move both crawler handles to front from off, but move right crawler handle farther to front than left crawler handle; right crawler will turn faster than left crawler.

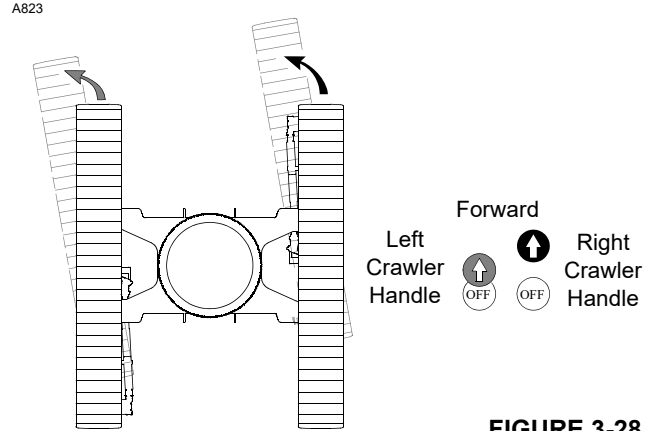


FIGURE 3-28

- 13. To make a GRADUAL RIGHT TURN, reverse step 11.
- 14. To COUNTER-ROTATE LEFT (Figure 3-29), move right crawler handle to front from off and move left handle to rear from off.

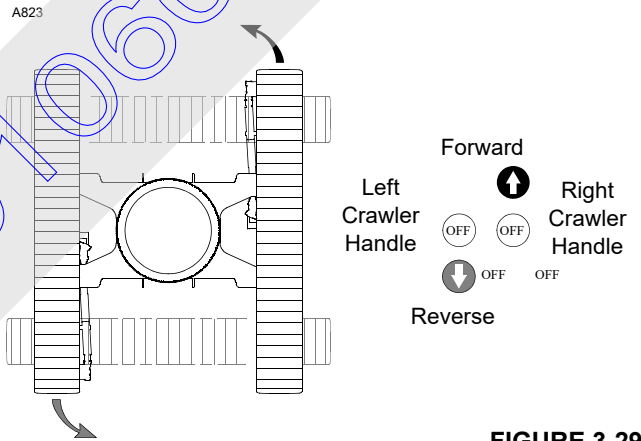


FIGURE 3-29

- 15. To COUNTER-ROTATE RIGHT, reverse step 13.
- 16. Slowly move both crawler handles to off to stop traveling and to hold crane in position.
- 17. Turn on travel park switch.

### Luffing Jib Setup Mode

For current production cranes not equipped with a Luffing Jib Limit Bypass switch, the Luffing Jib Setup Mode must be turned on before the limits identified in [Table 3-3, Page 3-24](#) can be bypassed.

1. Enter the function mode in the main display ([Figure 3-30](#)).

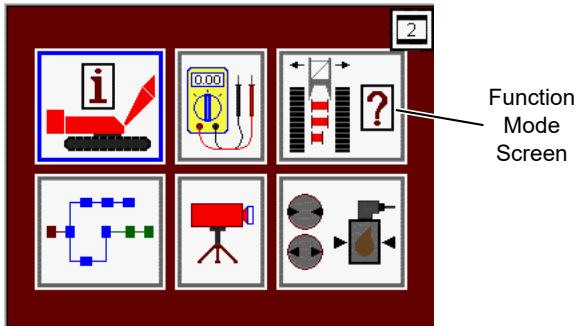


FIGURE 3-30

2. Scroll to and enter the setup mode screen ([Figure 3-31](#)).

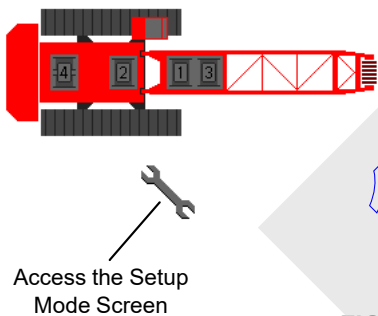


FIGURE 3-31

3. The screen shown in [Figure 3-32](#) will appear on display.

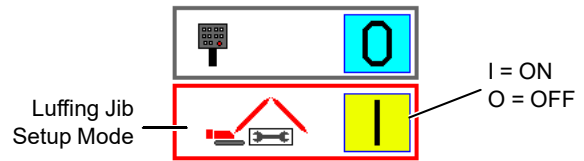


FIGURE 3-32

4. Turn the luffing jib setup mode on (or off when done with luffing jib setup).
5. Rotate limit bypass switch (D4) clockwise and release. The limits will remain bypassed for 10 seconds.
6. Move the desired control handle (luffing hoist, boom hoist, load drum) in the required direction. The limits will remain bypassed for as long as the handle is moved in either direction.
7. The limits will remain bypassed for 10 seconds after the control handle(s) is returned to off.

**NOTE:** When the luffing jib setup mode is on, the crane setup fault is turned on and the alarm in the cab sounds intermittently.

## STOPPING ENGINE/ LEAVING CRANE UNATTENDED



### WARNING

#### Moving Load/Tipping Crane Hazard!

Operator shall not leave operator's cab until crane, loads, and boom have been secured against movement.

Changing weather conditions including but not limited to: wind, ice or snow accumulation, precipitation, flooding, lightning, etc. should be considered when determining the location and configuration of a crane when it will be left unattended.

1. Travel crane onto a level surface; **do not leave crane unattended on a grade.**
2. Turn on travel park switch.
3. Swing rotating bed to desired position. Then turn on swing park switch.
4. Lower all loads to ground and fully apply drum working brakes (if equipped with brake pedals).
5. Turn on drum park switch for each load drum.
6. If possible, lower boom and luffing jib onto blocking at ground level.

If the boom and luffing jib cannot be lowered, as determined by a qualified designated person, they must be securely fastened from movement by wind or other outside forces (see Wind Conditions in Capacity Chart Manual).

**NOTE:** The designated person shall be familiar with the job site limitations, the crane configuration, and the expected weather conditions.

7. Check that all control handles are off.
8. Decrease engine speed to idle.  
Allow engine to idle for three to five minutes so it cools evenly.
9. Stop engine.
10. Remove all keys from cab to **prevent unauthorized operation.**
11. Lock operator's cab windows and door to **prevent unauthorized entry.**

## REMOTE CONTROLS



### WARNING

#### Read Instructions!

Avoid death or serious injury to personnel and damage to crane:

- Read Crane Assembly and Disassembly Instructions in Section 4 before operating remote controls.

The following instructions identify and describe operation of remote controls used for crane assembly and disassembly.

### General

The following instructions identify and describe operation of remote controls. Disregard any control not equipped on your crane.

This crane has two types of remote controls:

- Set-up remote control shown in [Figure 3-35](#). Store remote control in left side enclosure until needed.
- Manually controlled handles for crawler pins and jacking remote controls on front of carbody shown in [Figure 3-36](#).

### Set-Up Remote Control

See [Figure 3-35](#) for the following procedure.

Set-up remote control can be operated in any mode.

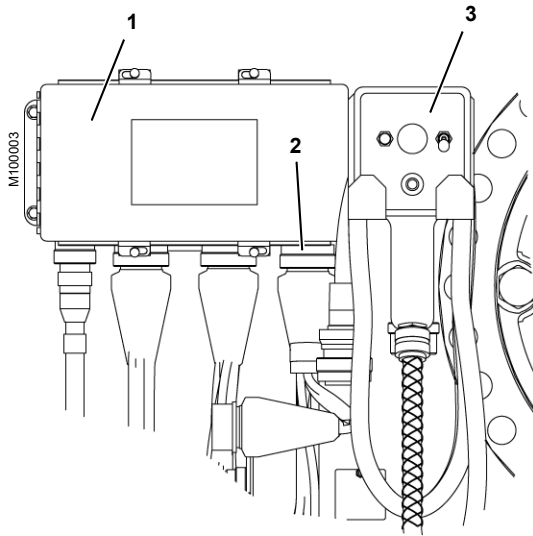
A slight delay is normal from the time a remote toggle switch is enabled to the time a corresponding function operates.

On current production cranes:

- The swing/travel alarm will sound continuously when a function is being operated by the remote control.
- Cranes meeting 2010 European requirements, the controls in the operator's cab and the carbody manual controls cannot be operated when the set-up remote control mode is on.

To operate set-up remote control, proceed as follows:

1. Remove remote control from left side enclosure, near node-3.
2. Disconnect W36 cable from W\*6 receptacle on node-3 ([Figure 3-33](#)).
3. Connect set-up remote cable to W\*6 receptacle on node-3 ([Figure 3-33](#)).



Item	Description
1	Node-3
2	W*6 Receptacle
3	Remote

FIGURE 3-33

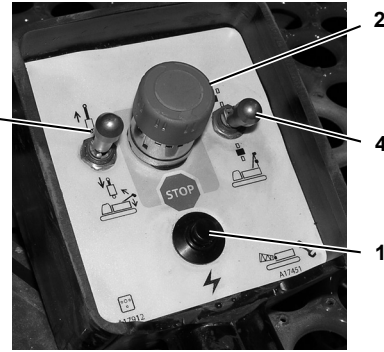
- In function mode screen, enter remote control data box (Figure 3-34).
- Scroll up or down to turn on (I) remote control.



14-COM-3-23

FIGURE 3-34

- Remote control ON prompt remains in display until it is turned off.
- Exit remote control data box to save setting.
- Hold down power button on remote control.
- Move selected switch up or down to operate function.



P2424

FIGURE 3-35

**1 – Power Switch**

DEPRESS button to TURN ON power to operate remote controls.

RELEASE button to TURN OFF power to remote controls.

**2 – Stop Switch**

DEPRESS knob to STOP the engine and all remote controlled functions in an emergency only — for example: if a function does not stop when the control is released to off or any other uncontrolled motion of a function is observed.

Always use ignition switch in cab to stop engine for normal operating conditions.

**Beware — when knob is pushed down, engine stops and any function being operated comes to an abrupt stop.**

**NOTE:** The knob must be pulled UP to RESTART the engine and operate remote controlled functions.

**3 – Gantry Cylinders**

Move toggle UP and hold to RAISE gantry (extend cylinders).

Release toggle to CENTER to STOP gantry. Valves on the cylinders lock the gantry in position.

Move toggle DOWN and hold to LOWER gantry (retract cylinders).

Read Crane Assembly and Disassembly Instructions in Section 4 for gantry/mast raising and lowering instructions.

**4 – Back Hitch Pins**

Move toggle UP and hold to DISENGAGE back hitch pins.

Release toggle to DOWN position to ENGAGE back hitch pins.

Read Crane Assembly and Disassembly Instructions in Section 4 for back hitch pins assembly/disassembly instructions.

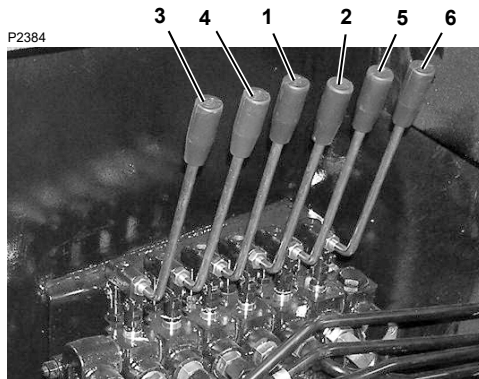


### Manual Controlled Handles

The speed at which jacks and pins operate depends on control handle movement and/or engine speed. To provide adequate speed, the engine must be operated at middle to high idle. All control handles are spring returned to **off**.

On current production cranes:

- The swing/travel alarm will sound continuously when a function is being operated with a carbody manual control.
- Cranes meeting 2010 European requirements, the controls in the operator's cab and the setup remote controls cannot be operated when a carbody manual control is being operated.



Right Front of Carbody

FIGURE 3-36

#### Crawler Pin Controls

- 1 – Right Crawler Pin Handle and
- 2 – Left Crawler Pin Handle

Push handle TOWARD carbody to ENGAGE crawler connecting pins. Crawler locking pins must be installed to lock connecting pins in engaged position (read Crane Assembly and Disassembly Instructions in Section 4).

Release handle to CENTER to stop pins.

Pull handle AWAY from carbody to DISENGAGE crawler connecting pins. Crawler locking pins must be removed before pins can be disengaged (read Crane Assembly/Disassembly and Disassembly Instructions in Section 4).

#### Carbody Jack Controls

- 3 – Right Front Jacking Handle,
- 4 – Right Rear Jacking Handle,
- 5 – Left Rear Jacking Handle, and
- 6 – Left Front Jacking Handle

Push handle TOWARD carbody to RAISE carbody (extend jack).

Release handle to CENTER to stop jack. Valves on the jack lock it in position.

Pull handle AWAY from carbody to LOWER carbody (retract jack).

### WARNING Moving Part Hazard!

Avoid serious injury:

- Keep feet clear of moving jacks
- Warn all personnel to stay clear of jacks while they are being extended
- If remote pins or outriggers are not visible from the control handles, use a signal person or spotter that can ensure personnel are clear

### CAUTION Machinery Damage!

Avoid damage to carbody jacks:

- Fully retract jacks before traveling

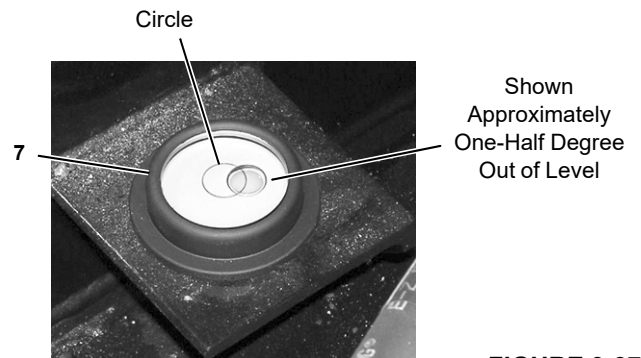
#### 7 – Carbody Level

Indicates crane levelness from front to rear and from side to side while jacking the carbody. The level is mounted on the front of the carbody (Figure 3-10). The crane is level when the bubble is centered in the circle. The crane is one degree out of level when the bubble is touching the outside edge of the circle.

### WARNING Tipping Hazard!

Prevent crane from tipping over.

- Keep crane level while jacking
- Do Not rely on jacking system to **keep** unit level. Check level often



P2361

FIGURE 3-37



## DISPLAYS

### Display Controls

See [Figure 3-38](#) for the following procedure.

Menu screens for Rated Capacity Indicator/Limiter and crane is displayed with select buttons. Use the following controls to operate the display screens.

#### 1 – Rated Capacity Indicator/Limiter Display

Rated Capacity Indicator/Limiter display is on the left side of front console. See stand alone Rated Capacity Indicator/Limiter Operation document for operation.

#### 2 – Main Display

The main display is on the right side of the front console (these screens are described in this section).

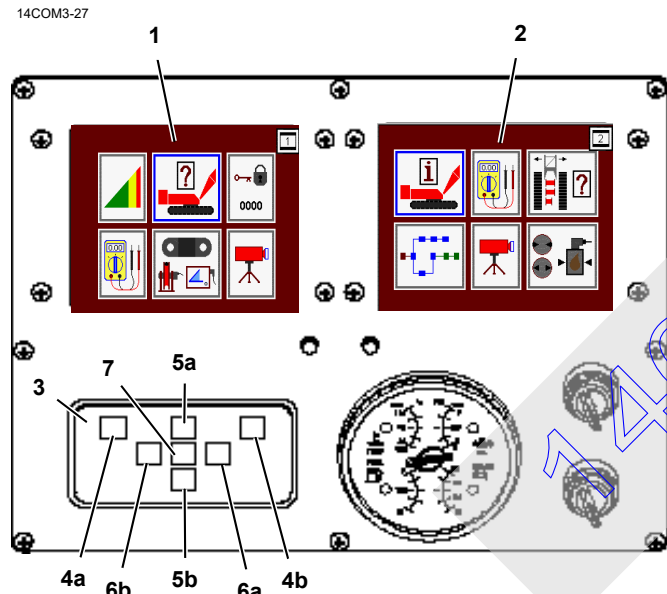


FIGURE 3-38

#### 3 – Display Touch Pad Controls

Contains all screen controls required to operate the Rated Capacity Indicator/Limiter display and Main display screens.

#### 4 – Display Select Buttons

- 4a. Press this button to select Rated Capacity Indicator/Limiter display 1.
- 4b. Press this button to select Main display 2.

#### 5 – Select Buttons

Use the green select touch pad buttons to select screen images, icons or data boxes, and values or icons within data boxes. Button (5a) scrolls up and button (5b) scrolls down.

#### 6 – Enter/Exit Buttons

Use the red touch pad buttons to enter (6a) or exit (6b) a screen or to change the screen's operating **level**. Use Enter button to enter a screen or go to the next level. Use Exit button to exit a screen or level.

#### 7 – Confirm Button

Use the purple Confirm touch pad button to start certain test routines from the screen and to confirm data when required.

### Display Brightness and Color Contrast

To adjust display contrast, proceed as follows:

1. Press desired display button (4a or 4b) and confirm button (7) at same time to select the desired display.
2. Release confirm button (first) and then release display button.
3. Press top select button (5a) to lighten display, or press bottom select button (5b) to darken display.
4. Press enter button (6a) to increase color intensity, or press exit button (6b) to decrease color intensity.
5. Press confirm button.

### Factory Default Display Settings

This procedure only applies to cranes with program number 14000 FCN 0.043 and newer.

1. Select the screen to adjust by holding the Confirm Button (7) and the desired Display Select Button (4a or 4b).
2. Release the Confirm button (7) first and then release the Display Select Button (4a or 4b).
3. Press select buttons (5a and 5b) at the same time to return to the factory default display settings.
4. Press Confirm button (7).
5. The selected Display (1 or 2) is reset to factory default settings.

### Blank Display

If a display goes blank on cranes with program number 14000 FCN 0.043 and newer, try the following procedure to restore a the display. **Do not return a display to Manitowoc until this procedure has been tried.**








1. Press desired display button (4a or 4b) and confirm button (7) at the same time.
2. Release the Confirm button (7) first and then release the Display Select Button (4a or 4b)
3. Press select buttons (5a and 5b) at the same time to return to the factory default display settings.
4. Press confirm button (7).




### Main GUI Display Format

The basic components for the Main GUI display format are the Information screen, Diagnostic screens, Function Mode screens, CAN Bus screen, Camera screens, and Pressure Test and Calibration screens. The appearance and function of each screen depends on the screen **level**. Some screen levels show icons and/or data boxes that can be selected to change parameters and/or to enter different screen levels.

### Screen Prompts

Screen prompts can appear on a selected screen if a fault condition exist or to prompt or confirm certain operator actions when required by the system. Prompt descriptions and icons are shown below.

- Rated Capacity Indicator/Limiter Display is item 1 and the Main Display is item 2. 
- Yellow alert symbol is displayed if a system fault occurs. See information screen topic in this section to access faults. 
- Yellow alert symbol is displayed if a Tier 4 engine fault occurs. See Tier 4 information screen topic in this section to access faults. 
- Purple confirm prompt appears when the operator shall start certain test routines from the screen and to confirm data when required. 
- Engine stopped symbol is displayed when engine is stopped. 
- Remote control symbol is displayed when remote control operation is selected. 
- RCL Bypass Prompt is displayed when the external override switch is turned on. Only for cranes meeting 2010 CE requirements. See the RCI/RCL Manual for instructions, 

- Jib Down Confirm Prompt is displayed when the luffing jib max down limit is contacted. Only for cranes meeting 2010 CE requirements. See [5. Luffing Jib Down Limit on page 3-31](#) for instructions, 
- Jib Up Confirm Prompt is displayed when luffing the jib max up limit is contacted. Only for cranes meeting 2010 CE requirements. See [4. Luffing Jib Up Limit on page 3-31](#) for instructions, 
- Data Logger Prompt is displayed for 60 seconds at startup if there is a problem with the data logger (most likely caused by the real time clock), 
- Free Fall Enabled Prompt is displayed when free fall is on for corresponding the drum.

The Manitowoc screen displays the following program items:

- Model/ Program Number (14000 FCN number shown)
- Con Number (009 000 000 008 shown)
- Screen Program Number (GUI 2.007 shown)



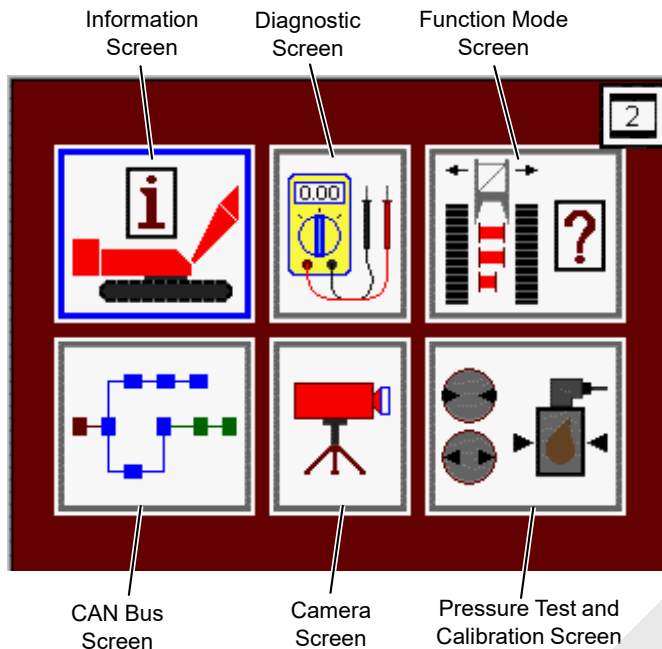
14COM3-28

FIGURE 3-39

### Menu Screen

See [Figure 3-40](#) for the following procedure.

The Menu screen is the **base** screen for the crane system. All other screens must be entered from this screen. Exiting from any screen will return to the Menu screen.



14COM3-27-2

FIGURE 3-40

The Menu screen shows six screen icons:

1. Information Screen icon
2. Diagnostic Screen icon
3. Function Mode Screen icon
4. CAN Bus Screen icon
5. Camera Screen icon
6. Pressure Test and Calibration Screen icon

The Menu screen operates on one **level** only.

- Use Select buttons to highlight icon that represents the screen to be entered. Press the Enter button to go to selected screen.
- To return to Menu screen, press Exit button until Menu screen appears.

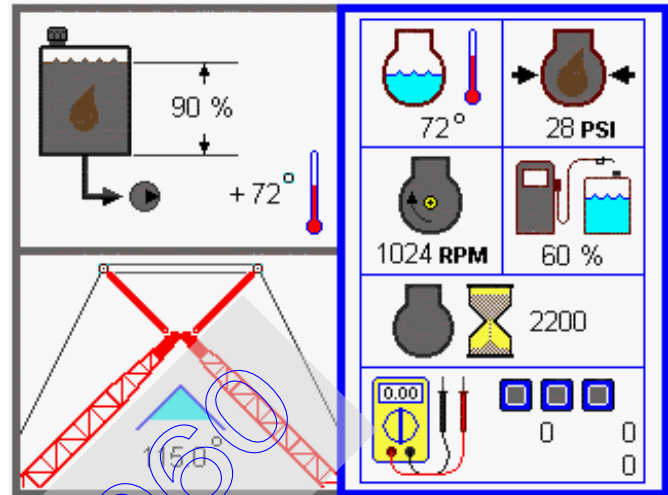
### Information Screen

See [Figure 3-41](#) for the following procedure.

Information screen shows all the general crane information required for viewing during normal operation. The screens contain three data boxes which may be individually tailored

to show the information items appropriate for the current crane application.

**When crane configuration is selected, the information screen appears with engine data box on right side and previously selected items on the left side as shown in [Figure 3-41](#).**



14COM3-30

FIGURE 3-41

The Information screen operates on three **levels**:

**Level 1** — Selected data box highlighted blue. Use Select buttons to highlight the data box to change.

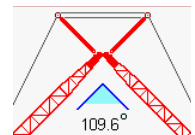
**Level 2** — Selected data box highlighted red. Use Select buttons to choose the information item to be shown in the highlighted data box.

**Level 3** — Selected data box highlighted green (if applicable). Use Select buttons to alter the information displayed in the highlighted data box.

The crane information items currently available (if equipped) for the two smaller data boxes on the left side of the screen are as follows:

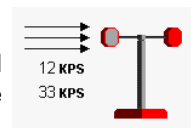
#### Boom to Luffing Jib Working Angle

Boom to luffing jib icon displays the boom to jib working angle between center line of boom and center line of luffing jib.



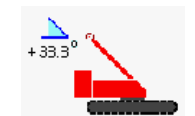
#### Wind Speed Indicator

Wind speed icon displays steady wind speed and maximum gust wind speed. The indicator is reset with Confirm button in **level 3**.



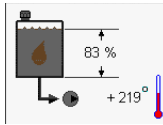
#### Mast Angle

Mast angle icon displays mast angle in degrees mast is positioned above transport position.



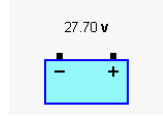
**Hydraulic Tank**

Hydraulic tank icon displays tank fluid level in percent and temperature in degrees.



**Battery**

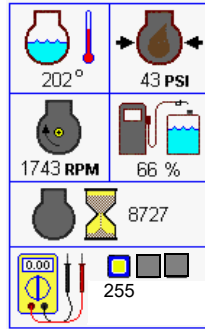
Battery icon displays active battery voltage.



**Engine (all)**

Engine data box displays the following engine items:

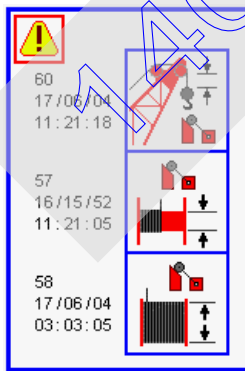
- Engine coolant temperature should be below 225°F (107°C)
- Engine oil pressure should be above 7.25 psi (0,5 bar)
- Engine speed in rpm, 1,050 rpm low idle 1,800 rpm high idle
- Fuel level in percent of fuel in main tank
- Engine hours displays the total number of hours engine has been run
- Diagnostic data with engine light and fault code. Amber warning light: service soon; red warning light: service immediately. See Engine Manufacturer’s Manual for detailed instructions.



**Crane Faults**

The fault data box displays the fault prompt with the fault number, date, and time of day listed in the order they occurred.

When one or more faults are enabled, an alarm turns on to warn the operator. The yellow alert symbol is displayed on active screen if a fault occurs. You shall go to Information screen to identify the fault. When the fault data box is



selected, the screen scrolls through the current faults one icon at a time. The fault history goes back in time to review past faults.

Press the Enter button to access **level 2** and use Select buttons to view past fault history. Press the Exit button to exit the fault screen. The alarm turns off when the cause of fault is corrected. Depending on crane configuration, not all listed faults are active or some of the fault listed may not be on your crane.

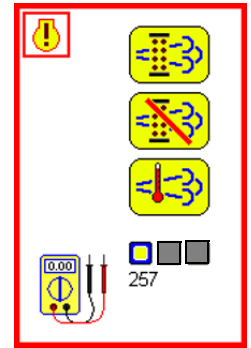
[Table 3-4](#) lists the Operating Limit faults that can appear in the fault screen. Operating limits faults **will** stop crane operation in the direction of the fault. **Corrective action must be take before continuing crane operation.**

[Table 3-5](#) lists the System Faults that can appear in the fault screen. System faults **will not** stop crane operation. **Correct all faults as soon as possible.**

**Tier 4 Engine Fault**

The Tier 4 engine fault screen displays the following icons:

- Engine fault prompt
- DPF regeneration in progress.
- DPF regeneration inhibited
- High exhaust temperature



Diagnostic data with engine light and fault code. Amber warning light: service soon; red warning light: service immediately. See Engine Manufacturer’s Manual for detailed instructions.


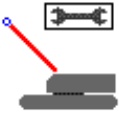

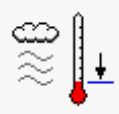
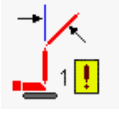

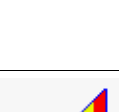


**WARNING**

**High Exhaust Temperatures!**

Active DPF Regeneration can occur at low engine idle as well as during crane operation. This may result in high exhaust temperature. Always keep personnel well away from the exhaust to prevent injury and possible death.

See [Page 3-55](#) for details on engine prompts.

Table 3-4 Operating Limits

Item	Description
	0-No Fault.
	6-Setup Mode — Indicates setup mode is on (Liftcrane Mast Capacities Chart selected in configuration screen of RCL or luffing jib limit bypass, if applicable, is on).
	34-Function Parked — Function inoperable because it is parked. Turn indicated park switch off or sit down in operator's seat.
	45-Air Temperature Low — Ambient temperature is below -22°F (-30°C). Crane engine allowed to start, but boom down and hoist up functions are locked out.
	49-Jib Maximum Up 1 Angle — This is a programmed limit which is activated at 168° by angle sensors in the boom and jib node controllers. Lower luffing jib to correct fault.
	50-Jib Maximum Down 1 Angle — This is a programmed limit which is activated by angle sensors in the boom and jib node controllers. This limit does not stop the luffing jib from lowering. It only turns on the alarm when the angle is reached. Raise luffing jib to correct fault.
	54-Rated Capacity Indicator/Limiter — Stops all drums. Land load or raise boom/jib.
	55-Boom Maximum Up — Limit switch stops boom in up direction. Move boom in lowering direction.
	57-Minimum Bail — Limit switch stops drum (x) from lowering or down direction. Move drum in hoisting or up direction.


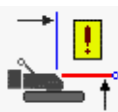
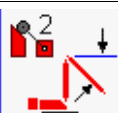
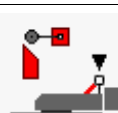
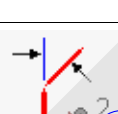


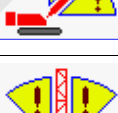


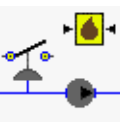
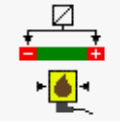
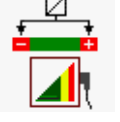
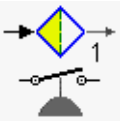
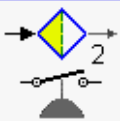
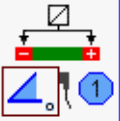
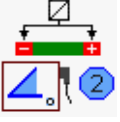

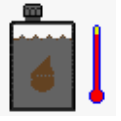
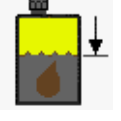
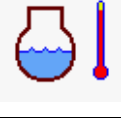




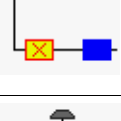

Item	Description
	60-Block Up Limit — Switch stops load drum and boom. Lower load or raise boom.
	66-Mast Too Far Forward — Live mast is below 172°. Raise live mast. Further lowering is not intended - <b>mast will fall</b> .
	67-Jib Maximum Down Limit — This limit stops the luffing jib from lowering when the switch is contacted. Raise luffing jib to correct fault.
	72-Gantry Down — When setup mode is on, live mast cannot be operated above 80° if gantry up switch is open. For any other mode, operation of drum 4 is not allowed if gantry down switch is open.
	73-Jib Maximum Up 2 Limit — This limit is activated by a limit switch when maximum up angle is reached. This limit stops the luffing hoist in the up direction when the boom to luffing jib angle is 171°. Lower luffing jib to correct fault.
	80-Invalid Configuration — Make sure selected Rated Capacity Indicator/Limiter configuration for load drums is correct.
	86-Boom Range Limiter — Up or down range limiter is tripped. Move boom in direction away from limit.
	87-Swing Range Limiter — Right or left range limiter is tripped. Swing rotating bed in direction away from limit.

Table 3-5 System Faults

Item	Description
	0-No Fault.
	10-Engine Alert Prompt — service Tier 3 engine immediately. See Engine Information Screen in this section to determine fault.
	30-Hydraulic Fan — Indicates a short in the fan pump wiring or the fan pressure sender is out of range. Fault 84 (Digital Output Disable) or Fault 41 (Transducer Voltage) will turn on at the same time.
	40-Hydraulic Vacuum Switch — Suction vacuum has increased above 5 inches Hg.
	41-Transducer Voltage — One or more hydraulic pressure sensors are out of range. Perform pressure sender test on <a href="#">Page 3-68</a> .
	42-Rated Capacity Indicator/Limiter Sensor Voltage— If a load sensing pin or load sensing sheave are not within allowable range — high or low, programmable controller will prevent crane operation.
	61-Filter 1 — Return Filter — Filter is dirty or plugged. Replace element or clean filter.
	62-Filter 2 — Suction Filter — Filter is dirty or plugged. Replace element or clean filter.
	63-Boom Angle Sensor — Boom angle sensor is out of normal range (0.15 to 4.85 Volts).
	64-Jib Angle Sensor — Luffing jib angle sensor is out of normal range (0.15 to 4.85 Volts).

Item	Description
	65-Hydraulic Fluid Temperature — Fluid temperature in hydraulic tank is below 70°F (21°C) or above 180°F (82°C).
	69-Hydraulic Fluid Level Low — Hydraulic oil at 60% full hot or cold. Fill tank.
	70-Engine Coolant Temperature — Engine coolant temperature above 225°F (107°C). Engine will automatically de-rates itself if this temperature is reached.
	71-Engine Oil Pressure Low — Oil pressure below 7.25 psi (0,5 bar).
	75-Fuel Level Low — Five percent fuel remaining in tank. Fill tank as soon as possible to prevent engine stoppage.
	78-Battery Voltage Low — Battery voltage below 18 volts. Determine cause of fault and correct.
	84-Digital Output Disable Fault — Digital output signal has a short circuit between computer node and output device. See CAN Bus screen information and Tables <a href="#">3-6</a> and <a href="#">3-9</a> to identify problem component.
	85-CAN bus Communication Error — One or more computer nodes are not communicating correctly. See CAN Bus screen to identify node(s).
	88-Remote Emergency Shutdown — Remote emergency stop shut down switch is pushed. Pull switch up to reset and allow engine to start.



### Diagnostic Screens

Diagnostic screens show a graphic of hydraulic circuit and status of all pumps, motors, valves, and switches that apply to crane function selected.

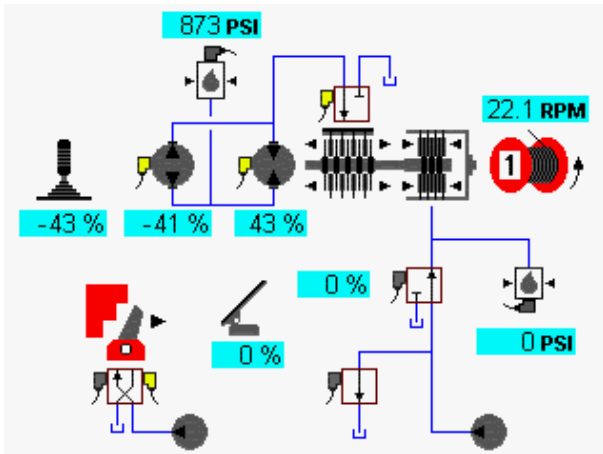


FIGURE 3-42

This view-only screen operates on two **levels**:

**Level 1**— Image of electrical tester shown (see Figure 3-40). Use Select buttons to highlight individual crane functions.

**Level 2** — Shows Diagnostic screen for highlighted crane functions.

The yellow alert symbol is displayed if a system fault occurs. You shall go back to Information screen to identify the fault.

#### Diagnostic Screen Component Icons

Each Diagnostic screen component icon is identified and described in the following paragraphs.

#### Control Handle

Displays system control handle command in percent from neutral with +raise and -lower for drums, +right and -left for swing, and +forward and -reverse for travel.



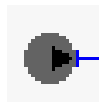
#### Variable Closed-Loop Pump

Pump command from neutral (0%) to +/-% of full displacement for drums, swing, and travel.



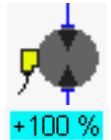
#### Gear Pump

Accessory pump or system charge pump.



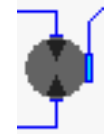
#### Variable Closed-Loop Motor

Displays motor command with 0% maximum displacement and 100% minimum displacement.



#### Closed Loop Variable Motor with Remote Pilot

Displays two-speed motor with remote pilot. This motor type is used for shifting motor speeds automatically when selected.



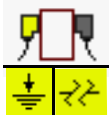
#### System Pressure Sender

Displays hydraulic pressure (psi/bar).



#### DIN Electrical Connector

DIN electrical connector changes to yellow when selected item is enabled. The yellow short to ground icon or open circuit icon indicates a circuit fault that must be serviced immediately.



**NOTE:** Variable outputs may show a yellow icon at all times.

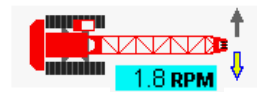
#### Drum Speed

Displays drum speed in revolutions per minute (rpm). Drum direction is also shown.



#### Swing Status

Displays status of swing. Swing right (shown) or swing left arrow is yellow when swing is enabled. Swing speed is shown in revolutions per minute (rpm).



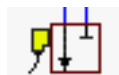
#### Track Symbol

Shows travel function. Travel (right shown) is yellow when function is operating.



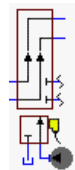
#### Valve Status

Displays status of a valve.



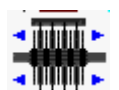
#### Pilot Valve

Displays status of an external piloted valve — a diversion valve would be an example of piloted valve.



#### Disc Brake

Displays disc brake status — applied or released (shown).





**Drum Pawl**

Displays pawl status — engaged or disengaged (shown).



**Mast Angle**

Displays mast angle in degrees mast is positioned above transport position.



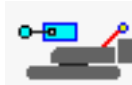
**Mast Raise Status**

Displays command state of mast raise cylinders.



**Gantry Down Limit Status**

Displays command state of gantry movement and gantry down limit switch— Open or closed (shown).



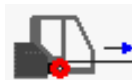
**Cab Tilt Status**

Displays command state of cab tilt cylinder — cab up or down (shown).



**Rigging Winch Status**

Displays command state of rigging winch — haul-in or pay-out (shown) line.



**Boom Hinge Pin Status**

Displays command state of boom hinge pin cylinders — extended (shown) or retracted.



**Cooling Fan Status**

Displays command state of cooling fan speed status as a percentage of maximum rpm.



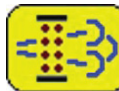
**Tier 4 Engine Diagnostic Information**

**Engine Prompt**

Yellow engine alert symbol is displayed if a Tier 4 engine fault occurs. Go to the Tier 4 Information Screen to determine the fault.

**DPF Icon**

Displays one of three conditions if regeneration inhibit switch is on (see [Page 3-15](#) and Engine Manufacturer’s Manual for additional information):



- ON when DPF is starting to fill. Turn off regeneration inhibit switch. No immediate action is required.
- FLASHING when DPF is nearly full. The operator may sense a reduction in power. Turn off regeneration inhibit switch. No immediate action is required.

- FLASHING and red engine light ON. The DPF is full. The operator will notice a significant reduction in engine power. Turn off regeneration inhibit switch and perform a stationary regeneration immediately (see Engine Manufacturer’s Manual for procedure).

**DPF Regeneration Inhibited Icon**



ON when active regeneration has been stopped by pressing the regeneration inhibit switch. Excessive use of regeneration inhibit will result in the need to service or replace the DPF.

**High Exhaust System Temperature (HEST) Icon**

ON when higher than normal exhaust temperatures exist due to DPF regeneration.

**Drum Diagnostic Screens**

Select drum icon in screen **level 1** as shown [Figure 3-43](#). Press Enter button to go to **level 2**.

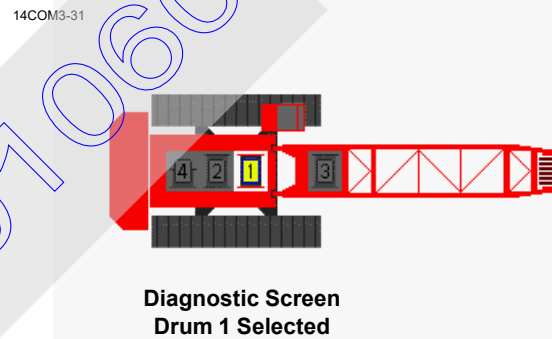


FIGURE 3-43

In drum example shown in [Figure 3-44](#), drum 1 function is shown lowering. Load drum 2 operation is similar.

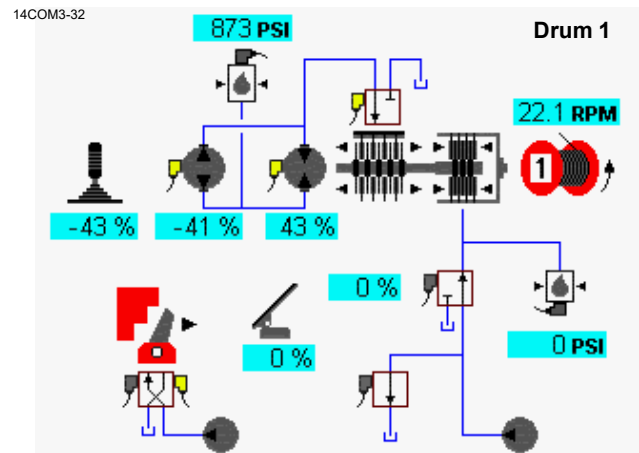


FIGURE 3-44

For load drum 3, left travel pump is dedicated to operate drum 3 motor through diverting valve when drum 3 is selected (Figure 3-45). Drum 3 is inoperable when traveling. Drum 3 can be configured as load drum or luffing jib.

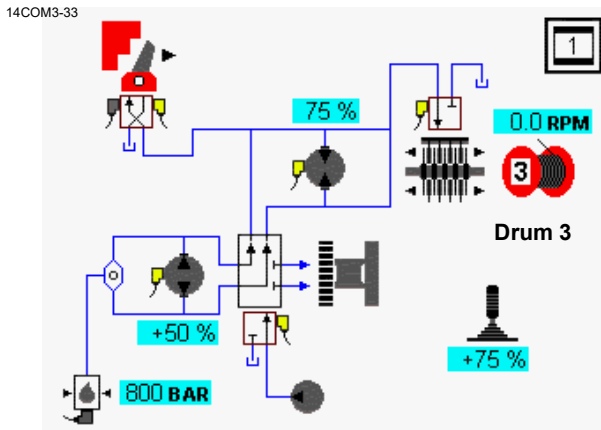
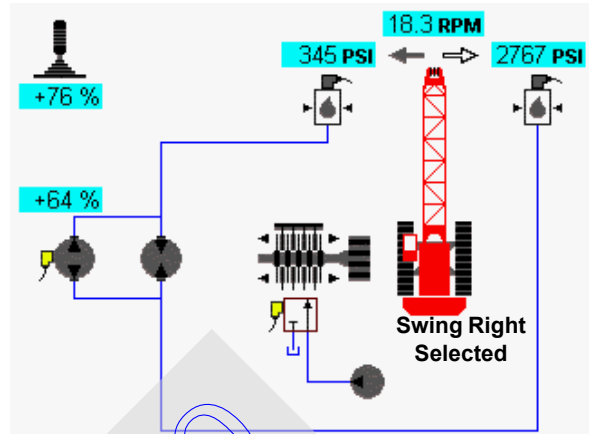


FIGURE 3-45

Swing system icons are displayed in Figure 3-48.

The example shows how swing function might appear when swinging right. Arrow symbols near each pressure sender indicate which sender monitors swing right and swing left pressures.



14COM3-36

FIGURE 3-48

In drum example shown in Figure 3-46, drum 4 function is shown not operating.

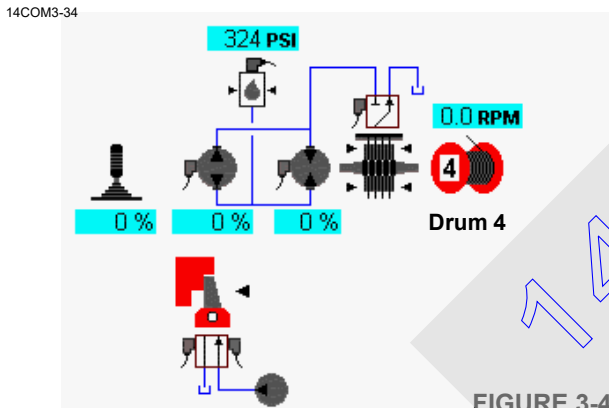
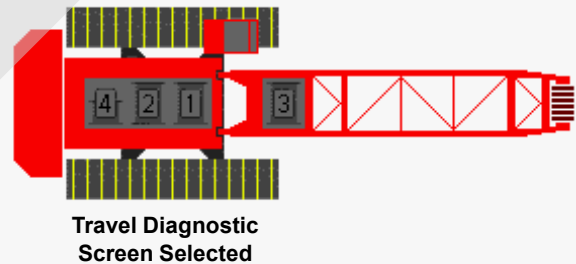


FIGURE 3-46

**Travel Diagnostic Screen**

Select travel icon in screen level 1 as shown in Figure 3-49. Press Enter button to go to level 2.

14COM3-37

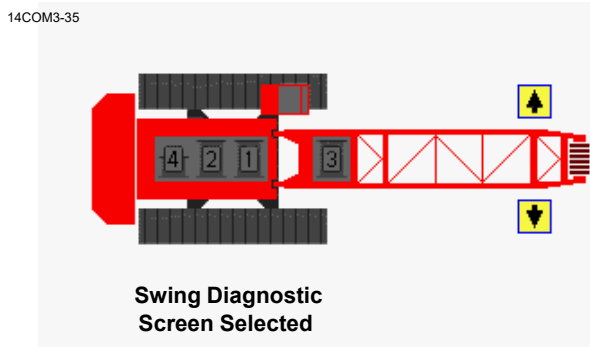


Travel Diagnostic Screen Selected

FIGURE 3-49

**Swing Diagnostic Screen**

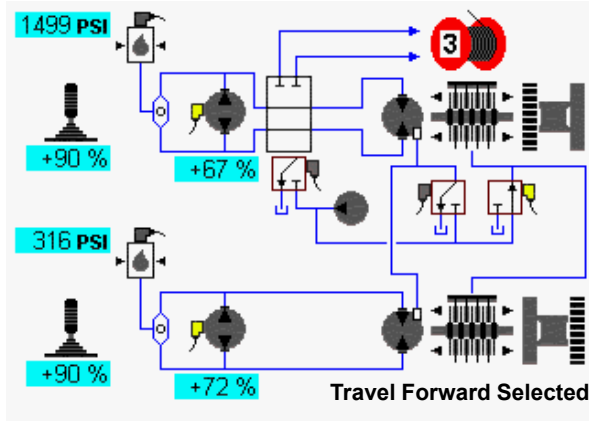
Select swing icon in screen level 1 as shown in Figure 3-47. Press Enter button to go to level 2.



Swing Diagnostic Screen Selected

FIGURE 3-47

In travel system example shown in Figure 3-50. Left travel pump is dedicated to operate drum 3 through diverting valve if drum 3 is selected. When left crane travel is enabled, drum 3 is disabled.

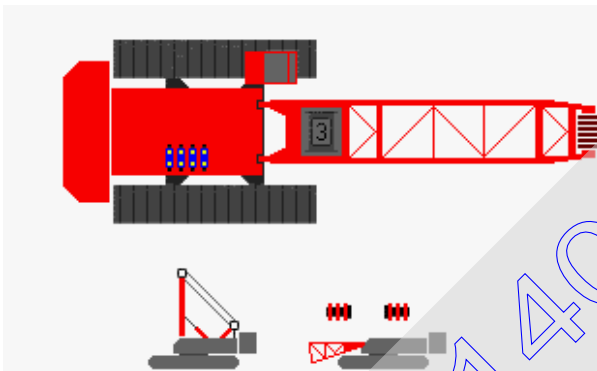


14COM3-38

FIGURE 3-50

**Accessory Diagnostic Screen**

Select mast cylinders and boom pin icons in screen *level 1* as shown in [Figure 3-51](#). Press Enter button to go to *level 2*.

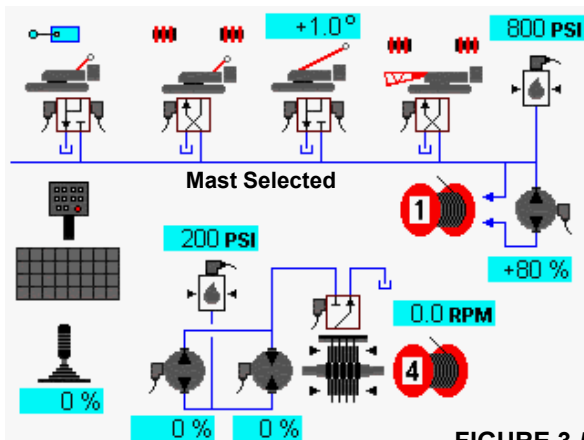


14COM3-39

FIGURE 3-51

In level 2, there are two diagnostic screens.

In diagnostic screen one, gantry cylinders up/down with up limit switch, back hitch pins, mast arm cylinders and boom hinge pins are shown ([Figure 3-52](#)).



14COM3-40

FIGURE 3-52

In diagnostic screen two, rigging winch, cab tilt and the cooling fan system are shown ([Figure 3-53](#)).

14COM3-39

FIGURE 3-53

**Function Mode Screens**

The Function Mode screens are used to enable/disable modes and to set operating parameters for the individual crane functions. This screen operates on four *levels*.

**Level 1**— Image of overall crane shown. Use Select buttons to highlight individual crane functions.

**Level 2** — Shows function mode screen for highlighted crane function. The selected mode or limit data box is highlighted blue. Use Select buttons to choose a mode or limit data box.

**Level 3** — The selected mode or limit data box highlighted red. Use Select buttons to enable/disable a mode or to set a limit.

**Level 4** — The selected mode or limit data box highlighted green. Use Select buttons to adjust the value, shown in data box.

To enable/disable modes or to set operating parameters for individual crane functions:

1. Press Enter or Exit buttons as required to go to *level 1*. Use Select buttons to highlight desired crane function.
2. Press Enter button to go to *level 2*. Use Select buttons to choose the mode or limit data box to access. Press Enter button to go to *level 3*.
3. Use Select buttons to enable/disable mode or to adjust operational parameter.
4. Press Enter button to go to *level 4* if required. Use Select buttons to adjust operational parameter.
5. Press Exit button as required to return to a previous *level* or to the Menu screen.

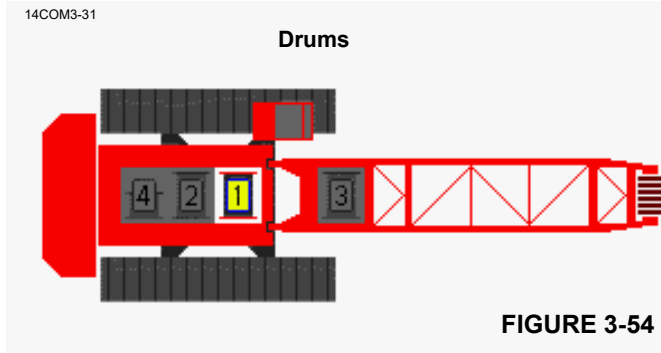
The yellow alert symbol is displayed if a system fault occurs. See Information screen to access faults.

**On** (I) and **off** (O) icons in some data boxes indicate and enable the electrical status of item.



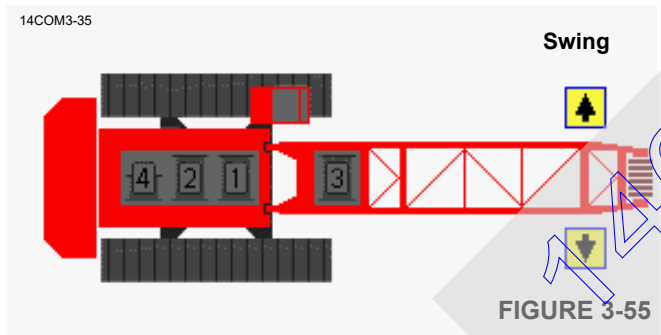
**Drum Functions**

Select drum functions 1 through 4 from screen shown below.



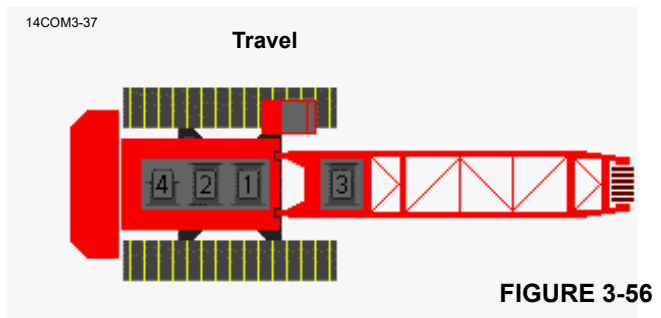
**Swing Functions**

Select swing functions from screen shown below.



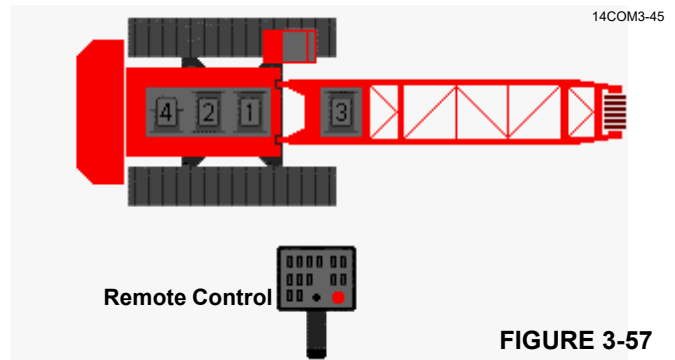
**Travel Functions**

Select travel functions from screen shown below.



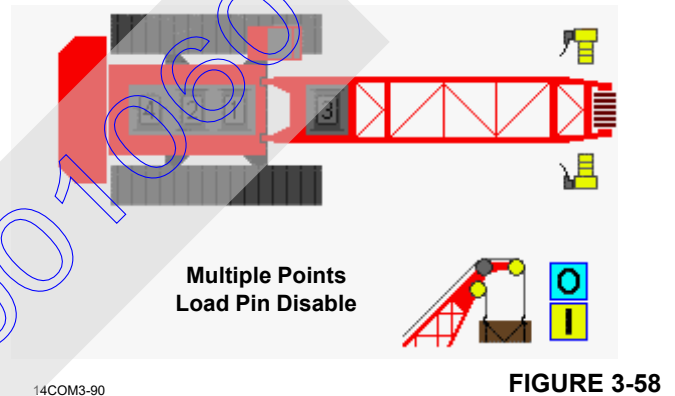
**Remote Control Functions**

Select remote control functions from screen below.



**Multiple Points or Load Pin Disable Functions**

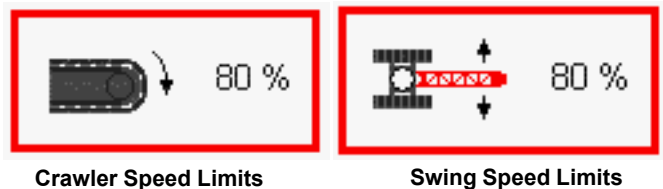
Select multiple points or load pin disable functions from screen below.



**Swing or Track Speed Limits**

See [Figure 3-59](#) in the following procedure.

Swing and crawler speeds can be selected. In **level 3**, the value shown in these data boxes can be adjusted with Select buttons to limit the function speed between 25% and 100% of maximum capability.



14COM3-46b

**FIGURE 3-59**

**Drum Functions**

See [Figure 3-60](#) in the following procedure.

In **level 3**, the **Drum Speed** value can be changed with Select buttons to limit function speed between 25% and 100% of maximum capability.

In **level 3** use Select buttons to turn on/off **Rigging Winch** option.

In **level 3** use Select buttons to turn on/off selected drum **Free Fall**.

In **level 3** use Select buttons to adjust **Drum Slip** for each drum to match the type of operation being performed.

- In most applications 100% slip should be selected so that load line pays out freely when a load is lowered with the brake pedal.
- For applications like pile driving, adjust slip so hammer follows the pile at the desired rate of speed.
- The corresponding brake pedal can be applied to stop the drum regardless of the slip adjustment. Likewise, the corresponding control handle can be pulled back or pushed forward to hoist or lower the load with full power.

In **level 3** use Select buttons to adjust **Pedal Response** between 0% and 100% to suit operator's needs. A high setting increases pedal movement required to control a small load and decreases pedal movement required to control a heavy load.

In **level 3** use Select buttons to turn the **Tandem Drum Mode** ON and OFF. The tandem drum mode allows two drums to be controlled at the same time with one control handle.

When the tandem drum mode is ON, the letter T appears above the innermost drum handle as shown in [Figure 3-19](#).

In the tandem drum mode, the crane's programmable controller operates both drums at the same speed so the load rises and lowers in a level position. If desired, Drum 2

handle can be used to tip the load to a desired attitude. The load will remain in that attitude until it is leveled with Drum 2 handle.

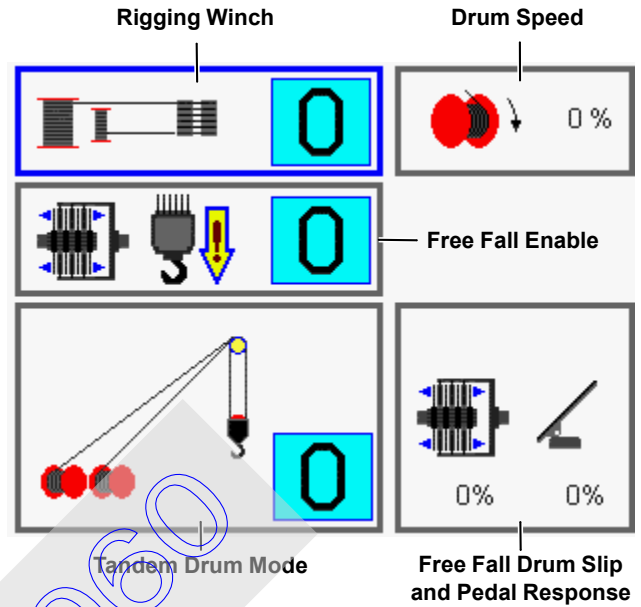


FIGURE 3-60

**Swing Torque**

See [Figure 3-61](#) in the following procedure.

In **level 3**, value shown in this data box can be adjusted with Select buttons to torque between 25% and 100% of maximum capability.



14COM3-47

FIGURE 3-61

**Boom or Swing Motion Limiter Mode**

See [Figure 3-62](#) in the following procedure.

**NOTE:** Motion limiter mode data boxes do not appear unless crane has this option.

In **level 3**, use Select buttons to enable or disable the motion limiter mode. When in **level 3** with motion limiter mode enabled, the controller monitors and stores the maximum right/left or up/down angles during operation. After exiting **level 3**, these angles are used to limit boom or swing motion.

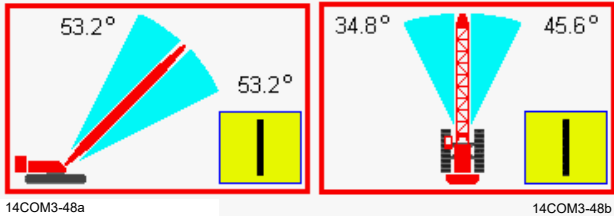
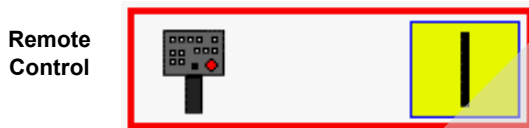


FIGURE 3-62

**Remote Control**

See [Figure 3-63](#) in following procedure.

In **level 3**, use Select buttons to enable or disable remote control.



14COM3-23

FIGURE 3-63

**Multiple Points or Load Pin Disable Functions**

See [Figure 3-64](#) in the following procedure.

Multiple points can be selected when two load points are used to lift a single load. Go to Rated Capacity Indicator/Limiter screen and enter pass code (0064) to unlock access to multiple points screen. In **level 3**, enter multiple points screen and select **On** (I).

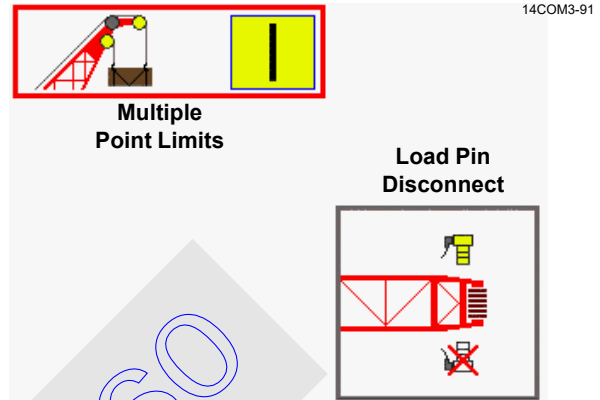


FIGURE 3-64

If a load pin disable fault (42) occurs, load sensing with one load sensor is an option. Go to Rated Capacity Indicator/Limiter screen and enter pass code (0064) to unlock access to load pin disable screen. In **level 3**, enter load pin disable screen and select sensor to be disabled. Top sensor icon is left side of boom and bottom sensor icon (with red X) is right side of boom.

**Fan Function**

See [Figure 3-65](#) in the following procedure.

The fan speed can be set above a minimum 50% of rated speed in increments of 5% (to 55%, 60%, 65%, etc.). **This minimum is pre-set by the manufacturer and should only be adjusted by the manufacturer.**

14CSM3-30

55%

FIGURE 3-65

14001060

**THIS PAGE INTENTIONALLY LEFT BLANK**



### CAN Bus Diagnostic Screen

See [Figure 3-66](#) for the following procedure.

The CAN bus diagnostic screen is for technicians. The screen displays CAN bus packet and node information, engine status, history status, and boom status. Any node that is yellow indicates that communication is lost to that node.

The CAN Bus screen operates on two **levels**:

**Level 1** — Packet number data box highlighted blue

**Level 2** — Packet number data box highlighted red

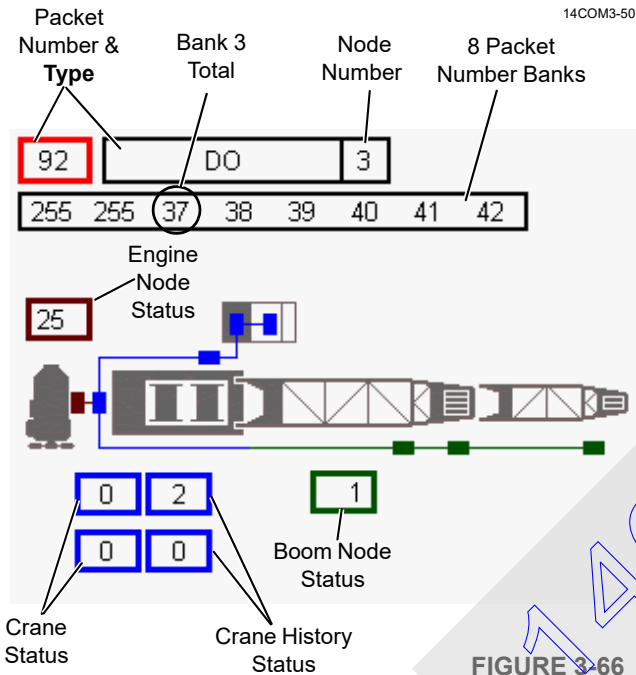


FIGURE 3-66

#### Packet Information

The top row of the screen contains CAN Bus packet number (92). Enter desired packet number in the first data box by using Select buttons.

Packet type (DO) is displayed on top middle data box.

Related node (3) is indicated in top last data box.

Packet contents are displayed in the eight banks under the row. Packet content and format depends on packet type. Many packets are not easily interpreted by other than factory technical personnel and their content is not discussed in this publication.

Each individual input/output is assigned a number (identifier) in the binary system (powers of two). The identifiers of all inputs/outputs that are ON (active) for each bank are added for a total of 0 – 255. The number displayed for each bank is the **sum** of all identifiers that are ON in that bank. Each possible ON/OFF combination per bank has a unique total.

To determine the status of an individual digital input or output, you need to know the CAN packet number (see [Table 3-7](#) and [Table 3-8](#)). For example: **Drum 1 Park Switch** has a packet number of **CAN92-3-4**.

The first part of the number – **CAN92** – indicates that the individual input or output is located in packet **92** of **CAN** communications.

The second part of the number – **3** – indicates the **bank** where the individual information is shown on the CAN screen.

The third part of the number – **4** – is the item **identifier**.

Determine the status of the individual input/output by checking the total in bank three (37). Find 37 in the numbered column of [Table 3-9](#) - Bank Identifier Numbers. In the corresponding row the identifier numbers that are ON in the bank are shaded (1, 4, 32 = 37). In the above example identifier **4** is shaded so **Drum 1 Park Switch** is ON.

#### Digital Output Disable Fault

See [Figure 3-66](#) for following procedure.

The control system is capable of detecting an open or short circuit in most of the system's digital outputs. When **Fault 84-Digital Output Disable** is shown in fault section of Information screen, use the following procedure:

1. Scroll through packet numbers 30, 31 and 33.
2. Banks 1, 2 and 3 of CAN screen should display number 255.
3. If a number less than 255 is displayed in banks 1, 2, and 3, use the Bank Identifier Numbers in [Table 3-9](#) to determine which bit(s) are **off**.
4. Use [Table 3-6](#) - Digital Output Disable, to determine what outputs are not working.
5. Investigate indicated outputs for short to ground, short to shield or other problem.

#### Engine Node Status

Engine displays node bus status that is for factory use only. Communication number should to be under 64.

#### Crane Status

The two crane status banks on left side display crane errors. Crane status banks should display zero. The number displayed in crane status top bank correspond to numbered communication errors listed below:

- Number 1 - Node-2 is not communicating
- Number 2 - Node-3 is not communicating
- Number 4 - Node-4 is not communicating
- Number 8 - Node-5 (optional) is not communicating

- Number 32 - Bin node is not communicating
- Number 64 - RIN (remote input node) node is not communicating
- Number 128 - Engine node is not communicating

**NOTE:** Bottom crane status bank is not used at this time.

**Status History**

Status history banks display errors since power was cycled.

**NOTE:** Bottom status history bank is not used at this time.

**Boom Node Status**

Boom node status displays boom top and jib communication. The box indicates what nodes may be available on the bus:

- Number 0 is no nodes present
- Number 1 is boom top node
- Number 2 is luffing jib node
- Number 3 is boom top node and luffing jib node

- 31-1-32
- 31-1-64
- 31-1-128
- 31-2-1
- 31-2-4
- 31-2-8
- 31-2-16
- 31-2-32
- 31-2-64
- 31-2-128
- 31-3-1
- 31-3-2
- 31-3-4
- 31-3-8
- 31-3-16
- 31-3-32
- 31-3-64
- 31-3-128

- Mast Cylinders Extend Switch
- Drum 1 (Front Drum) Free Fall Pulse
- Drum 2 (Rear Drum) Free Fall Pulse
- Free Fall and Rigging Winch Enable
- Travel Brake
- Travel Motor
- Swing Brake
- Drum 3 (Auxiliary/Luffing) Diverter
- Drum 3 (Auxiliary/Luffing) Pawl - In
- Boom Hinge Pins Disengage
- Drum 4 (Boom Hoist) Pawl - In
- Back Hitch Pins Disengage
- Cab Tilt Down Switch
- Cab Tilt Up Switch
- Drum 3 (Auxiliary/Luffing) Pawl - Out
- Drum 4 (Boom Hoist) Pawl - Out
- Drum 3 (Auxiliary/Luffing) Brake
- Drum 3 (Auxiliary/Luffing) Motor

**Table 3-6 Digital Output Disable**

CAN Packet Number	Item Description		
30-1-1	Rated Capacity Indicator/Limiter Beacon	33-1-1	Rigging Winch - Haul In
30-1-2	Handle 4 Rotation Indicator	33-1-2	Rigging Winch - Pay Out
30-1-4	Handle 2 Rotation Indicator	33-1-4	Drum 2 (Rear Drum) Motor
30-1-8	Cooler Fan Pump	33-1-8	Drum 2 (Rear Drum) Brake
30-1-32	Handle 3 Rotation Indicator	33-1-16	Rigging Winch Brake
30-1-64	Handle 1 Rotation Indicator	33-1-32	Right Side Swing/Travel Alarm
30-1-128	Seat Switch and Left Handle Center Switch	33-1-64	Swing Auto Lubrication
30-2-1	Right Console	33-1-128	Node 4 Sensor
30-2-8	Right Console and Handle Center Switch	33-2-1	Travel Auto Lubrication
30-2-16	Engine Temperature Gauge	33-2-2	Swing/Travel Alarm Left Side
30-2-128	Engine Oil Pressure Gauge	33-2-4	Drum 4 (Boom Hoist) Pump - Raise
30-3-8	Fuel Level Gauge	33-2-8	Drum 4 (Boom Hoist) Pump - Lower
30-3-4	Sensor Supply (Cab)	33-2-16	Drum 4 (Boom Hoist) Motor
30-3-32	Rated Capacity Indicator/Limiter Alarm	33-2-32	Drum 4 (Boom Hoist) Brake
30-3-64	Foot Throttle	33-2-64	Swing Pump - Right
30-3-128	System Fault Alarm	33-2-128	Swing Pump - Left
		33-3-1	Left Track Pump - Forward
31-1-1	Drum 1 (Front Drum) Motor Control	33-3-2	Left Track Pump - Reverse
31-1-2	Drum 1 (Front Drum) Brake Solenoid	33-3-4	Right Track Pump - Reverse
31-1-4	Gantry Cylinders Retract Switch	33-3-8	Right Track Pump - Forward
31-1-8	Gantry Cylinders Extend Switch	33-3-16	Drum 2 (Rear Drum) Pump - Lower
31-1-16	Mast Cylinders Retract Switch	33-3-32	Drum 2 (Rear Drum) Pump - Raise
		33-3-64	Drum 1 (Front Drum) Pump - Lower
		33-3-128	Drum 1 (Front Drum) Pump - Raise

Table 3-7 Digital Input Reference Chart

CAN Packet Number	Item Description (Node Number)	CAN Packet Number	Item Description (Node Number)
CAN36-1-1	Handle (H4) Direction Signal (N2)	CAN84-4-64	Maximum Jib Angle Limit (N20)
CAN36-1-2	Handle (H3) Direction Signal (N2)	CAN84-4-128	Block-Up Limit 3 - Fixed (N20)
CAN36-1-4	Swing Holding Brake Switch (N2)	CAN85-2-64	Block-Up Limit 3 (N21)
CAN36-1-8	Swing Handle Direction Signal (N2)	CAN85-2-128	Block-Up Limit 4 (N21)
CAN36-1-16	Air Conditioning - On (N2)	CAN92-3-4	Front Drum (Drum 1) Park Switch (N1)
CAN36-1-32	Cab Tilt - Down (N2)	CAN92-3-16	Rear Drum (Drum 2) Park Switch (N1)
CAN36-1-128	Seat Safety Switch (N2)	CAN92-3-64	Travel Park Switch (N1)
CAN36-2-1	Left Track Direction Signal (N2)	CAN92-3-128	Mast Cylinders Retract Switch (N1)
CAN36-2-2	Handle (H1) Direction Signal (N2)	CAN92-4-1	Display Enter Switch (N1)
CAN36-2-4	Handle (H2) Direction Signal (N2)	CAN92-4-2	Confirm Switch (N1)
CAN36-2-8	Right Track Direction Signal (N2)	CAN92-4-4	Limit Bypass Switch (N1)
CAN36-2-16	Cab Tilt - Up (N2)	CAN92-4-8	Display Scroll Up Switch (N1)
CAN36-2-32	Travel Cruise (N2)	CAN92-4-16	Jib Up Limit Bypass Switch (N1)
CAN36-2-64	Travel Speed (N2)	CAN92-4-32	Display Scroll Down Switch (N1)
CAN38-1-64	Remote Control - Back Hitch Pins (N3)	CAN92-5-4	DPF Regen Inhibit (N1)
CAN40-1-64	Gantry Maximum Angle Limit (N4)	CAN92-5-16	DPF Regen Initiate (N1)
CAN55-1-64	Left Swing Limit Switch (N5)	CAN92-5-32	Engine Run/Start (N1)
CAN55-1-128	Right Swing Limit Switch (N5)	CAN92-6-4	Display 1 (N1)
CAN84-2-64	Block-Up Limit 2 - Upper Point (N20)	CAN92-6-16	Display 2 (N1)
CAN84-2-128	Block-Up Limit 1- Lower Point (N20)	CAN92-6-64	Display Exit Switch (N1)
CAN84-4-32	Minimum Jib Angle Limit (N20)	CAN92-6-128	Load/Luffing (Drum 3) Park Switch (N1)

Table 3-8 Digital Output Reference Chart

CAN Packet Number	Item Description (Node Number)	CAN Packet Number	Item Description (Node Number)
CAN20-1-1	Rated Capacity Indicator/Limiter Beacon (N2)	CAN21-3-16	Drum 3 (Auxiliary/Luffing) Pawl - Out (N3)
CAN20-1-2	Handle 4 Rotation Indicator (N2)	CAN21-3-32	Drum 4 (Boom Hoist) Pawl - Out (N3)
CAN20-1-4	Handle 2 Rotation Indicator (N2)	CAN21-3-64	Drum 3 (Auxiliary/Luffing) Brake (N3)
CAN20-1-8	Cooler Fan Pump Control (N2)	CAN21-3-128	Drum 3 (Auxiliary/Luffing) Motor Control (N3)
CAN20-1-32	Handle 3 Rotation Indicator (N2)	CAN23-1-1	Rigging Winch - Haul In (N4)
CAN20-1-64	Handle 1 Rotation Indicator (N2)	CAN23-1-2	Rigging Winch - Pay Out (N4)
CAN20-1-128	Seat Switch (N2)	CAN23-1-4	Drum 2 (Rear Drum) Motor (N4)
CAN20-2-1	Right Console (N2) (N2)	CAN23-1-8	Drum 2 (Rear Drum) Brake (N4)
CAN20-2-16	Engine Coolant Temperature (N2)	CAN23-1-16	Rigging Winch Brake (N4)
CAN20-2-64	Engine Fuel Level (N2) (N2)	CAN23-1-32	Right Side Swing/Travel Alarm (N4)
CAN20-2-128	Engine Oil Pressure Gauge (N2)	CAN23-1-64	Swing Auto Lubrication (N4)
CAN20-3-32	Rated Capacity Indicator/Limiter Alarm (N2)	CAN23-1-128	Hydraulic Fluid Level (N4)
CAN20-3-64	Foot Throttle (N2)	CAN23-2-1	Travel Auto Lubrication (N4)
CAN20-3-128	System Fault Alarm (N2)	CAN23-2-2	Rated Capacity Indicator/Limiter Alarm (N4)
CAN21-1-1	Drum 1 (Front Drum) Motor Control (N3)	CAN23-2-4	Drum 4 (Boom Hoist) Pump - Raise (N4)
CAN21-1-2	Drum 1 (Front Drum) Brake Solenoid (N3)	CAN23-2-8	Drum 4 (Boom Hoist) Pump - Lower (N4)
CAN21-1-4	Gantry Cylinders Retract Switch (N3)	CAN23-2-16	Drum 4 (Boom Hoist) Motor (N4)
CAN21-1-8	Gantry Cylinders Extend Switch (N3)	CAN23-2-32	Drum 4 (Boom Hoist) Brake (N4)
CAN21-1-16	Mast Cylinders Retract Switch (N3)	CAN23-2-64	Swing Pump - Right (N4)
CAN21-1-32	Mast Cylinders Extend Switch (N3)	CAN23-2-128	Swing Pump - Left (N4)
CAN21-1-64	Drum 1 (Front Drum) Free Fall Pulse (N3)	CAN23-3-1	Left Track Pump - Forward (N4)
CAN21-1-128	Drum 2 (Rear Drum) Free Fall Pulse (N3)	CAN23-3-2	Left Track Pump - Reverse (N4)
CAN21-2-1	Free Fall and Rigging Winch Enable (N3)	CAN23-3-4	Right Track Pump - Reverse (N4)
CAN21-2-4	Travel Brake (N3)	CAN23-3-8	Right Track Pump - Forward (N4)
CAN21-2-8	Travel 2-Speed (N3)	CAN23-3-16	Drum 2 (Rear Drum) Pump - Lower (N4)
CAN21-2-16	Swing Brake (N3)	CAN23-3-32	Drum 2 (Rear Drum) Pump - Raise (N4)
CAN21-2-32	Drum 3 (Auxiliary/Luffing) Diverter (N3)	CAN23-3-64	Drum 1 (Front Drum) Pump - Lower (N4)
CAN21-2-64	Drum 3 (Auxiliary/Luffing) Pawl - In (N3)	CAN23-3-128	Drum 1 (Front Drum) Pump - Raise (N4)
CAN21-2-128	Boom Hinge Pins Disengage (N3)	CAN29-1-128	Air Temperature Sender /Terminal Plug (N5)
CAN21-3-1	Drum 4 (Boom Hoist) Pawl - In (N3)	CAN29-2-1	Swing Motor Encoder (N5)
CAN21-1-32	Mast Cylinders Extend Switch (N3)	CAN29-2-2	Swing Limit Switch (N5)
CAN21-1-64	Drum 1 (Front Drum) Free Fall Pulse (N3)	CAN92-1-4	RCL Warning L.E.D. (N1)
CAN21-1-128	Drum 2 (Rear Drum) Free Fall Pulse (N3)	CAN92-1-32	RCL Caution L.E.D. (N1)
CAN21-2-1	Free Fall and Rigging Winch Enable (N3)	CAN92-2-1	Jib Bypass/Swing Park Switch (N1)
CAN21-2-4	Travel Brake (N3)	CAN92-2-2	Overhead Panel (N1)
CAN21-3-2	Back Hitch Pins Disengage (N3)	CAN92-2-4	Drums 1, 2 and 3 Park Switches (N1)
CAN21-3-4	Cab Tilt Down Switch (N3)	CAN92-2-128	Drum 4/Travel Park Switches (N1)
CAN 21-3-8	Cab Tilt Up Switch (N3)	CAN92-6-32	Swing Park Switch (N1)

Table 3-9 Bank Identifier Numbers

	1	2	4	8	16	32	64	128
1								
2								
3								
4								
5								
6								
7								
8								
9								
10								
11								
12								
13								
14								
15								
16								
17								
18								
19								
20								
21								
22								
23								
24								
25								
26								
27								
28								
29								
30								
31								
32								
33								
34								
35								
36								
37								
38								
39								
40								
41								
42								
43								

	1	2	4	8	16	32	64	128
44								
45								
46								
47								
48								
49								
50								
51								
52								
53								
54								
55								
56								
57								
58								
59								
60								
61								
62								
63								
64								
65								
66								
67								
68								
69								
70								
71								
72								
73								
74								
75								
76								
77								
78								
79								
80								
81								
82								
83								
84								
85								
86								

	1	2	4	8	16	32	64	128
87								
88								
89								
90								
91								
92								
93								
94								
95								
96								
97								
98								
99								
100								
101								
102								
103								
104								
105								
106								
107								
108								
109								
110								
111								
112								
113								
114								
115								
116								
117								
118								
119								
120								
121								
122								
123								
124								
125								
126								
127								
128								
129								

Dark shaded boxes indicate ON; white boxes OFF

Table 3-9 Bank Identifier Numbers (continued)

	1	2	4	8	16	32	64	128
130								
131								
132								
133								
134								
135								
136								
137								
138								
139								
140								
141								
142								
143								
144								
145								
146								
147								
148								
149								
150								
151								
152								
153								
154								
155								
156								
157								
158								
159								
160								
161								
162								
163								
164								
165								
166								
167								
168								
169								
170								
171								
172								

	1	2	4	8	16	32	64	128
173								
174								
175								
176								
177								
178								
179								
180								
181								
182								
183								
184								
185								
186								
187								
188								
189								
190								
191								
192								
193								
194								
195								
196								
197								
198								
199								
200								
201								
202								
203								
204								
205								
206								
207								
208								
209								
210								
211								
212								
213								
214								
215								

	1	2	4	8	16	32	64	128
216								
217								
218								
219								
220								
221								
222								
223								
224								
225								
226								
227								
228								
229								
230								
231								
232								
233								
234								
235								
236								
237								
238								
239								
240								
241								
242								
243								
244								
245								
246								
247								
248								
249								
250								
251								
252								
253								
254								
255								

Dark shaded boxes indicate ON; white boxes OFF

### Camera Screen (Optional)

The camera screen (not shown) displays camera options and items for selecting and operating. Camera options include up to three different cameras to monitor drum spooling and area behind crane.

Use Select buttons to select camera screen on Menu screen. Press Enter button to access screen.

Use Select buttons to select desired camera view.

Press Exit button until Menu screen appears.

### Pressure Test and Calibration Screen

Pressure Test and Calibration Screen (see Figure 3-67) is used to initiate and monitor four hydraulic test and calibration procedures.

The screen shows pump commands and pressure levels for all primary crane functions. Use data box in upper left corner of screen to select and start a specific test or calibration procedure.

Pressure Test and Calibration screen operates on two levels.

**Level 1** — Test data box highlighted blue.

**Level 2** — Test data box highlighted red. Use Select buttons to choose test or calibration procedure.

All test and calibration procedures must be run at a particular engine speed. If a test is started at the wrong speed, the appropriate prompt shown below appears in data box and the procedure is aborted.

#### Engine Off

A yellow engine pressure 0 icon indicates that test must be run with engine off.



#### Engine Low Idle

A yellow engine pressure down arrow icon indicates that test must be run with engine at low idle.



#### Engine High Idle

A yellow engine pressure up arrow icon indicates that test must be run with engine at high idle.



The yellow open circuit icon indicates a circuit fault that must be serviced immediately.



The yellow short to ground icon indicates a circuit fault that must be serviced immediately.



### Pressure Sender Test

See Figure 3-67 for the following procedure.

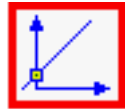
The pressure sender test calculates the zero-pressure output level for each pressure sender.

Perform this test when:

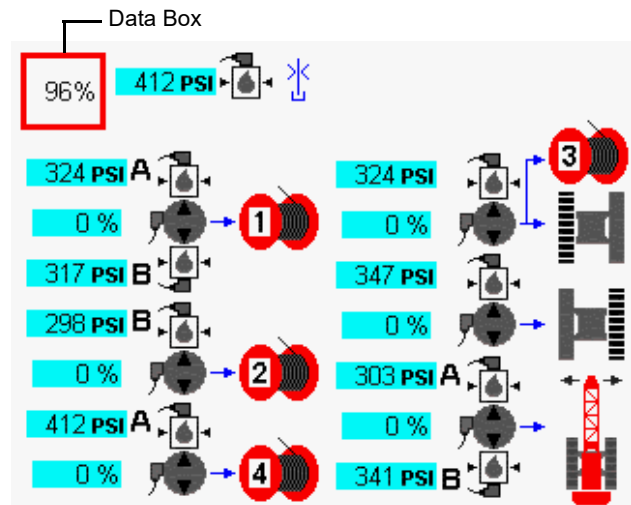
- A new pressure sender is installed
- A new controller node that monitors pressure senders is installed
- A new master node or master node software is installed
- Pressure readings are noticeably in error

Test pressure senders as follows:

1. Stop engine and turn ignition switch to **run** position. Push Enter button to go to Pressure Test and Calibration screen from Menu screen.
2. Press Enter button to go to **level 2**. Use Select buttons to show PRESSURE SENDER icon in data box.
3. Press Confirm button to start test.
4. Test starts and percent of completion is displayed in data box.
5. When test is complete, pressure sender icon reappears in data box.



Pressure senders must show a signal within a specified range during this test. Any sender signal out of this range is highlighted yellow. Troubleshoot failed senders to determine cause of fault.



14COM3-51

FIGURE 3-67



**Control Calibration**

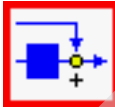
See [Figure 3-68](#) for the following procedure.

Control calibration calculates pump threshold command level for all drum and swing functions.

Perform this calibration when:

- A new pump or motor is installed in a drum or swing
- A new master node or software is installed
- Operation indicates threshold is in error
  - Excessive handle motion or time required to initiate motion
  - Inability to smooth start motion

Calibrate controls as follows:

1. Apply **all** park brakes with switches on control console.
2. Start and run engine at **high idle**.
3. Press Enter button to go to Pressure Test and Calibration screen from Menu screen.
4. Press Enter button to go to **level 2**. Use Select buttons to show CONTROL CALIBRATION icon in data box. 
5. Press Confirm button to start test.
6. Calibration starts and percent of completion is displayed in data box.
7. When calibration is complete, control calibration icon reappears in data box.

Pump threshold command levels must be within a specified range during this test. Any pump requiring a threshold command level outside this range is highlighted yellow. Troubleshoot failed circuit to determine cause of fault.

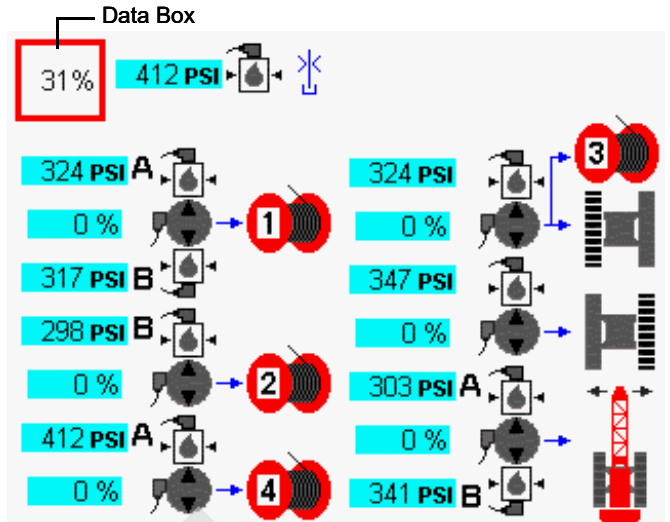


FIGURE 3-68

**High Pressure Test**

See [Figure 3-69](#) for the following procedure.

The high pressure test checks ability of all primary crane functions to reach and hold high pressure. This test generally is used only as a shop procedure on new cranes. It can also be used as a quick way to test hydraulic components in primary hydraulic circuits.

**CAUTION:** Only perform this high pressure test when absolutely necessary and by a qualified service technician.




**WARNING**  
**High Pressure Hazard!**

This test generates maximum pressure in the main hydraulic circuits. Defective brakes may allow unintended motion during test. Move crane to an area where such motion is not a hazard.

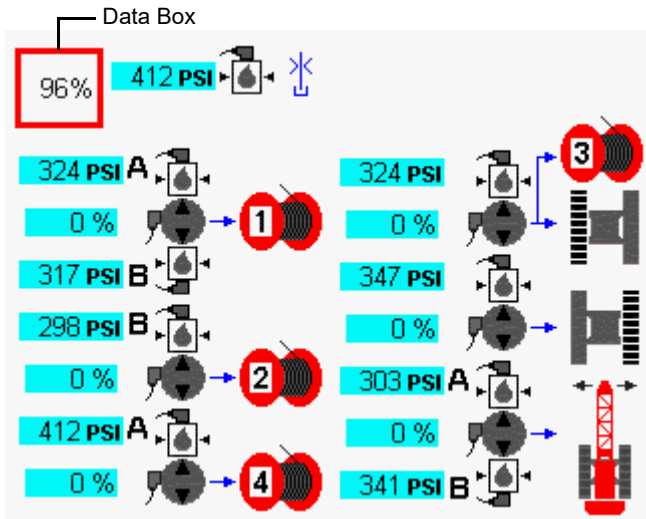
We recommend an observer to monitor functions the operator cannot see.

Be prepared to stop engine if unintended motion occurs.

Test high pressure as follows:

1. Apply **all** park brakes with switches on control console.
2. Start and run engine at **high idle**.
3. Press Enter button to go to Pressure Test and Calibration screen from Menu screen.
4. Press Enter button to go to **level 2**. Use Select buttons to show HIGH PRESSURE icon in data box. 
5. Press Confirm button to start test.

- Test starts and percent of completion is displayed in data box.



14COM3-53

FIGURE 3-69

Test charge pressure as follows:

- Apply **all** park brakes with switches on control console.
- Start and run engine at **low idle**.
- Press Enter button to go to Pressure Test and Calibration screen from Menu screen.
- Press Enter button to go to **level 2**. Use Select buttons to show LOW PRESSURE icon in data box.
- Press Confirm button to start test.
- Test starts and percent of completion is displayed in data box.
- When test is complete, charge pressure icon reappears in data box.

Charge pressure levels must be within a specified range during this test. Any pump that failed to maintain charge pressure within a specified range is highlighted yellow. Troubleshoot failed circuit to determine cause of fault.

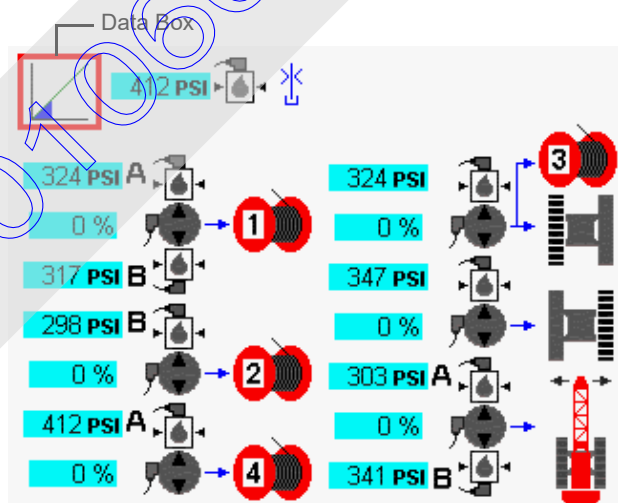
- When test is complete, high pressure icon reappears in data box.

Maximum pressure levels must be reached within a specific pump command range during this test. Any pump requiring a command in excess of this range or failed completely to generate maximum pressure is highlighted yellow. Troubleshoot failed circuit to determine cause of fault.

**Charge Pressure Test**

See [Figure 3-70](#) for the following procedure.

Charge pressure test checks the ability of all primary crane functions to build proper charge pressure. This test generally is used only as a shop procedure on new cranes. It can also be used as a quick way to test hydraulic components in primary hydraulic circuits.



14COM3-54

FIGURE 3-70

## WIND CONDITIONS

Wind adversely affects lifting capacity and stability as shown in [Figure 3-71](#). The result could be loss of control over load and crane, even if load is within the crane's capacity.



### WARNING

#### Tipping Crane Hazard!

Judgment and experience of qualified operators, job planners, and supervisors must be used to compensate for affect of wind on lifted load and boom by reducing ratings or operating speeds, or a combination of both.

Failing to observe this precaution can cause crane to tip or boom and/or jib to collapse. Death or serious injury to personnel can result.

---

Wind speed (to include wind gusts) must be monitored by job planners and supervisors.

The wind speed at boom or jib point can be greater than wind speed at ground level. Also be aware that the larger the sail area of the load, the greater the wind's affect on the load.

As a general rule, ratings and operating speeds must be reduced when:

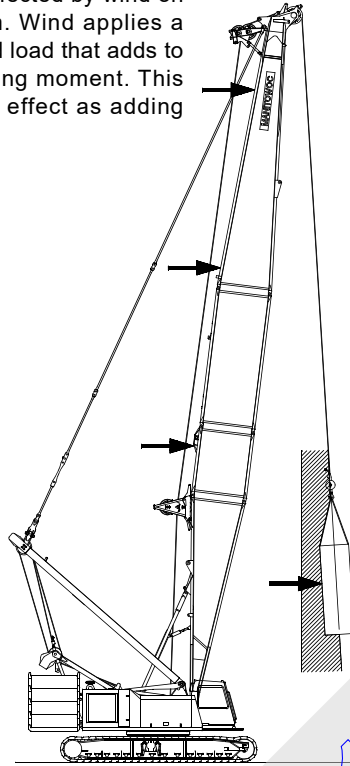
***Wind causes load to swing forward past allowable operating radius or sideways past either boom hinge pin.***

For wind conditions specific to this crane, see Wind Conditions Chart at end of this section or, if applicable, see wind conditions in Capacity Charts provided with crane and attachments.

14001060

A910

Forward stability is affected by wind on the rear of the boom. Wind applies a force to the boom and load that adds to the crane's overturning moment. This action has the same effect as adding load to the hook.



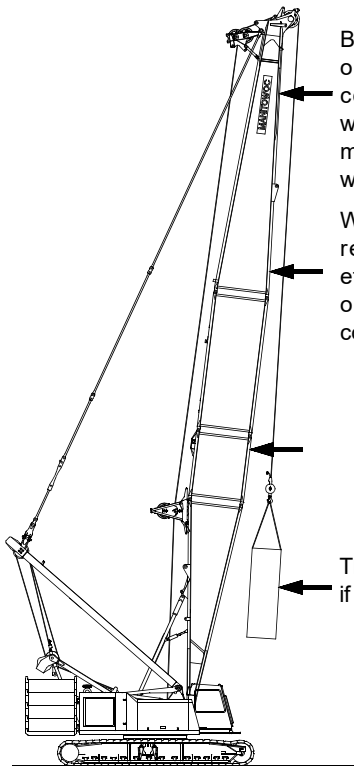
The wind's affect on the rear of the load increases load radius. This condition can result in an overload hazard, possibly causing the crane to tip or the boom to collapse.

To avoid this hazard, reduce operating speeds and load (see Wind Conditions Chart at end of this section or see wind conditions in Capacity Charts if applicable).

Backward stability is affected by wind on the front of the boom. This condition is especially dangerous when the boom is at or near the maximum angle when operating without load.

Wind forces on the front of the boom reduce the normal forward tipping effect of the boom. The crane can tip or the boom can collapse if this condition is not avoided.

The boom can buckle and collapse if the load contacts the boom.



Boom strength is affected the most when the wind acts on the side of the boom.

The wind's affect on the side of the load can cause the load to swing out past the boom hinge pin. This condition can result in excessive side load forces on the boom, possibly causing the crane to tip or the boom to collapse.

To avoid this hazard, reduce operating speeds and load (see Wind Conditions Chart at end of this section or see wind conditions in Capacity Charts if applicable).

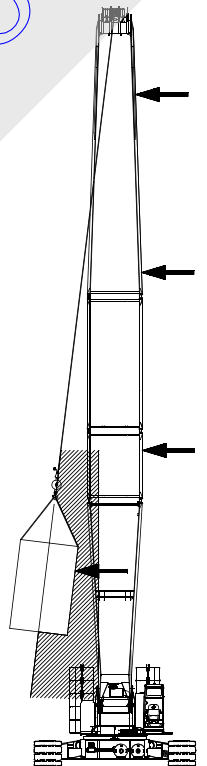


FIGURE 3-71

## PREPARATION FOR COLD WEATHER

### Crane Limitations

The static load carrying limitations of the steels used in Manitowoc cranes is not affected by cold weather. Manitowoc's capacity charts are acceptable for use in cold weather.

Dynamic loads (impact and shock) can affect the steels used in Manitowoc cranes when operating in cold weather. Dynamic loads are created by traveling, sudden application and release of load, and duty-cycle operations.

To prevent possible damage to crane and its attachment when operating during cold weather Manitowoc recommends:

- At -5 to -22°F (-21 to -30°C) — Avoid impact or shock loading of crane and attachment. Operations involving hydraulic cranes should be conducted with regard to potential failure of hydraulic components.
- At -23 to -40°F (-31 to -40°C) — De-rate crane by 40% for all lift operations. Halting all lifts should be considered. Duty-cycle operation is prohibited.
- Below -40°F (-40°C) — All operation (lift and duty-cycle) is prohibited except in extreme emergencies, and then only with approval from a competent engineer who has de-rated crane accordingly.

### Wire Rope

Wire rope manufacturers indicate that wire rope will not become brittle in temperatures down to -30°F (-34°C). Lubrication may be a problem during extreme cold weather as normal wire rope lubricants may harden and chip off, leaving rope without lubrication.

Consult your wire rope supplier for recommended cold-weather lubricants.

### Cold Weather Starting Aid

Engine startup at temperatures below 40°F (4°C) requires use of a cold weather starting aid.



#### **DANGER**

#### **Engine Explosion Hazard!**

Crane engine has an air intake pre-heater, do not spray any combustible starting aid (ether) into air intake.

Pre-heater will ignite ether causing a severe explosion and/or burns.

### Coolant and Oil Pan Heaters

A coolant and oil pan heater is installed on the engine. The heaters use an electric heating element to heat the coolant and oil inside the engine when crane is idle. Contact your Manitowoc dealer for availability and installation of cold weather heater package.

**Engine heaters must be unplugged when engine is running to prevent cooling system from overheating.**

### Cooling System

The cooling system must be kept full and be protected from freezing at the lowest expected ambient temperature. See engine manual for antifreeze recommendations.

A mixture of 40% antifreeze and 60% water provides freeze protection to -35°F (-37°C). A mixture of 60% antifreeze and 40% water provides freeze protection to approximately -60°F (-51°C). 100% antifreeze will freeze at -10°F (-23°C).

### Batteries

To provide maximum cranking power and to prevent the batteries from freezing, they must be kept fully charged (1.26 to 1.28 specific gravity) and warm when crane is idle during cold weather.

It is recommended that batteries be stored indoors or heated with a battery heater when crane is idle.

Be aware that:

- A battery with a 50% charge freezes at -16°F (-27°C). A battery with a 100% charge freezes at -70°F (-57°C).
- A battery with a 100% charge retains only 40% of its cranking power at -0°F (-18°C). At -20°F (-29°C), the same battery retains only 18% of its cranking power.

### Engine Oil

See engine manufacturer's manual for recommendations.

### Fuel Oil

See engine manufacturer's manual for recommendations.

### Gear Oil

#### **Hydraulic Cranes**

Use a gear oil which meets MIL-L-2105C specification or API-GL-5 classification. Change to one of the following viscosities when corresponding temperature range will be encountered:

- 75W-90 below -10°F (-23°C)
- 80W-90 above -10 to 100°F (-23 to 38°C)
- 85W-140 above 100°F (38°C)

## Hydraulic Oil

### General

Optional thermostatically controlled heaters (120 or 240 volt) can be installed in hydraulic tank to aid in cold-weather startup.

Heaters are designed to keep the oil temperature 30°F (17°C) warmer than ambient air temperature. Contact your Manitowoc dealer for availability and installation of cold weather heater package.

***Hydraulic tank heaters must be unplugged when engine is running to prevent hydraulic system from overheating.***

Change hydraulic system oil to ISO Grade 15 when the expected ambient temperature will remain at 32°F (0°C) or below.

Change hydraulic system oil to ISO Grade 46 when the expected ambient temperature will remain above 32°F (0°C).

14001060

## COLD WEATHER HEATER PACKAGE

### General

An optional cold weather heater package has a 240 volt AC single phase power requirement. Heaters preheat critical machinery and lubricant sumps during cold weather shutdown.

A 240 volt receptacle is mounted on front of rotating bed and the circuit breaker panel is mounted on left side of rotating bed, behind operator's cab (see [Figure 3-72](#) and [Figure 3-73](#)).

When operated in an arctic climate — outside temperature continuously below 0°F (-18°C) and -30°F (-34°C) — crane should be equipped with heaters identified in this section and lubricated with the lubricants listed in Section 5.

### CAUTION

#### Machinery Damage!

Operating in an arctic climate without heaters can damage machinery during cold weather start-up due to lack of lubrication.

Heater package described in this section may not provide adequate protection when operating below -30°F (-34°C). Contact your Manitowoc dealer for recommendations.

#### Hydraulic Pump Damage!

To prevent damage to pumps, warm hydraulic oil to 60°F (16°C) minimum before operating crane in an arctic climate.

### Heaters

Heaters operate on 240 volt AC single phase electrical power supplied by a external power supply. Heater package includes the following:

- Cab front console strip heater (240 volts, 125 watts)
- Hydraulic reservoir heaters — Past (240 volts, 500 watts each) or Hydraulic reservoir heater — Current (240 volts, 1000 watts)
- Engine oil sump heater (120 volts, 300 watt)
- Battery pad heaters — Past (120 volts, 75 watts each) or

Battery pad heaters — Current (240 volts, 75 watts each)

- Engine coolant recirculation heater (120 volts, 1000 watts)

### Turning Heaters On

1. The external power supply must be disconnected. Then proceed as follows:
  - a. Check that main circuit breaker and each heater circuit breaker is off (see [Figure 3-72](#) - Past Production or [Figure 3-73](#) - Current Production).
  - b. Check that external power supply source is off.
  - c. Connect external power supply cord to receptacle at left side of rotating bed, behind operator's cab.
  - d. Turn on external power supply.
  - e. Turn on main circuit breaker.
  - f. Turn on each heater circuit breaker.



### WARNING

#### Electrocution Hazard!

Severe electric shock can cause death or serious injury. Crane owner/user shall make provisions for turning off electrical power supply before connecting power supply cord to crane.

### Turning Heaters Off

1. Turn off main circuit breaker.
2. Turn off each heater circuit breaker.
3. Perform remaining steps only if power supply cord will be disconnected or electrical system is being serviced:
  - a. Turn off external power supply.
  - b. Unplug power supply cord from crane.

### CIRCUIT BREAKERS

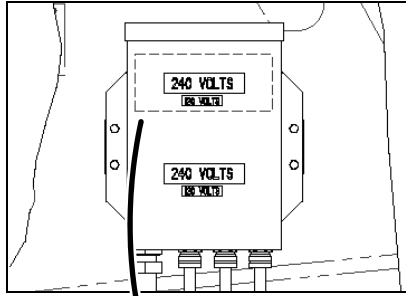
See Section 3 in the Service Manual for identification and location of circuit breakers used to protect crane's electric circuits.



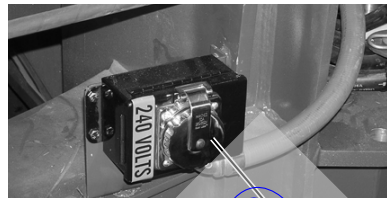
### Cold Weather Package — Past

Item	Description
1	Cold Weather Package 240 Volt Receptacle
2	Main Circuit Breaker
3	Cab Front Console Heater
4	Hydraulic Reservoir Heaters (2)
5	Engine Oil Heater, Battery Pad Heaters (2)
6	Engine Coolant Heater
7	Load Center Circuit Breakers Decal (symbols)

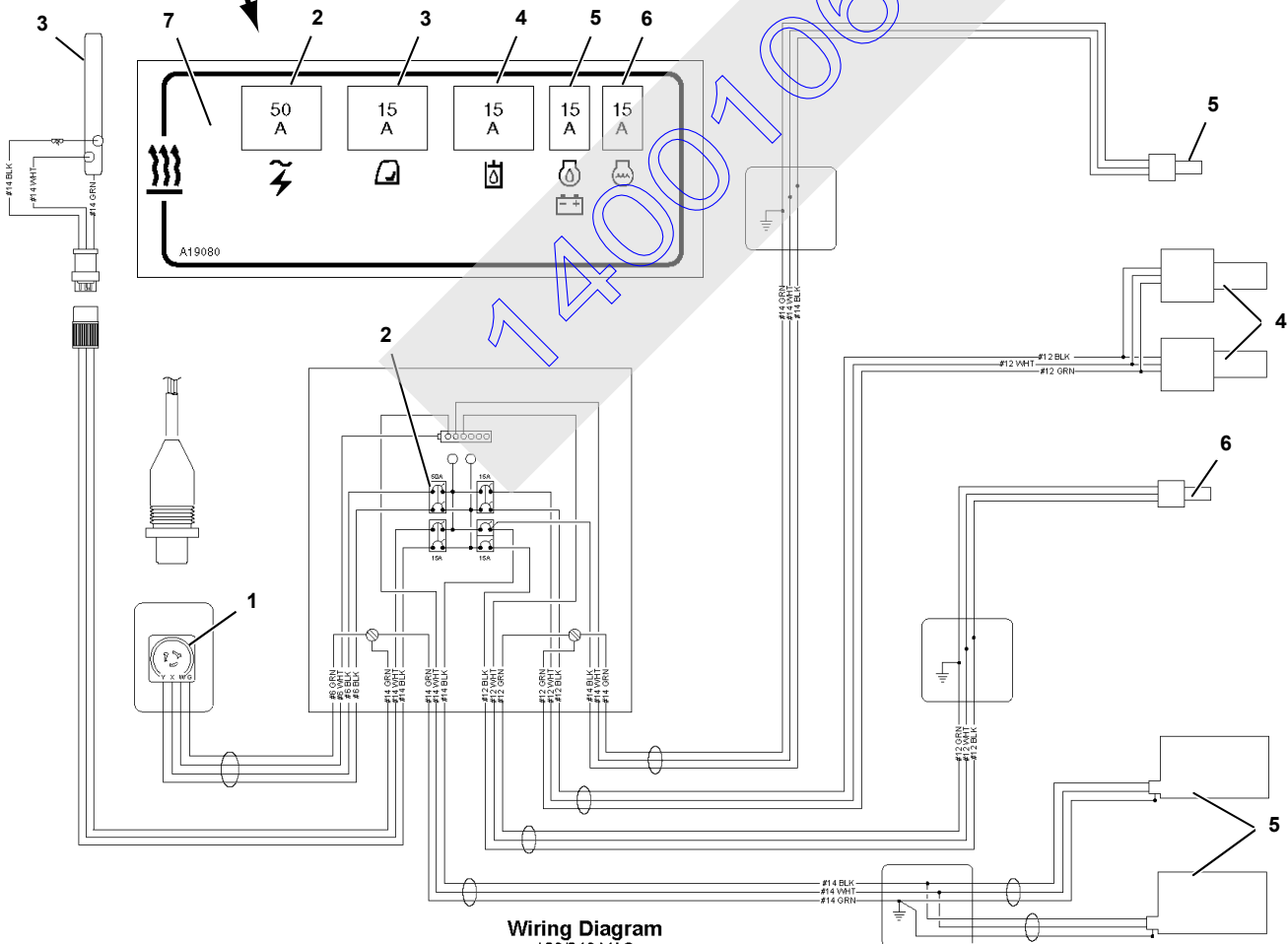
Left Side of Rotating Bed Behind Cab



Front of Rotating Bed



P2418

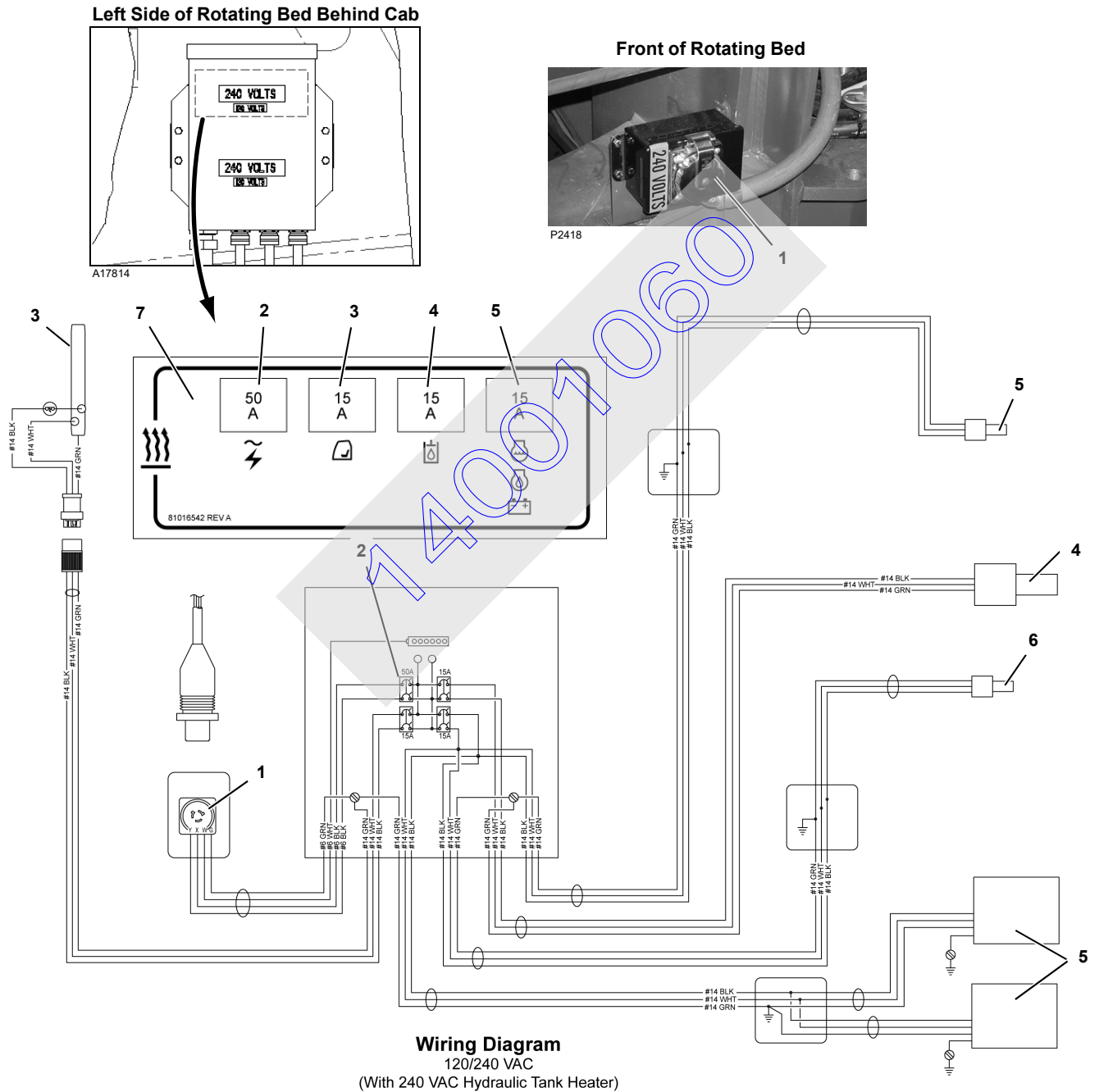


A17814

FIGURE 3-72

### Cold Weather Package — Current

Item	Description
1	Cold Weather Package 240 Volt Receptacle
2	Main Circuit Breaker
3	Cab Front Console Heater
4	Hydraulic Reservoir Heater
5	Engine Oil Heater, Battery Pad Heaters (2), Engine Coolant Heater
6	Not Used
7	Load Center Circuit Breakers Decal (symbols)



3

A17814

FIGURE 3-73

**THIS PAGE INTENTIONALLY LEFT BLANK**

14001060

# SECTION 4

## SET-UP AND INSTALLATION

### TABLE OF CONTENTS

Boom and Jib Assembly Drawings . . . . .	4-1
Liftcrane Mast Capacities . . . . .	4-1
Optional Attachments . . . . .	4-1
General Safety . . . . .	4-1
Crane Orientation . . . . .	4-1
Self-Erecting Equipment . . . . .	4-3
Assembly and Disassembly Notes . . . . .	4-3
Assembly and Disassembly Area . . . . .	4-3
Accessing Parts . . . . .	4-3
Crane Weights . . . . .	4-4
Handling Components . . . . .	4-4
Retaining Connecting Pins . . . . .	4-4
Cold Weather Mast Operation . . . . .	4-5
Shipping Crane Components . . . . .	4-5
Operating Controls . . . . .	4-6
Pre-Start Checks . . . . .	4-6
Engine . . . . .	4-6
Gear Boxes . . . . .	4-6
Hydraulic System . . . . .	4-6
Electric System . . . . .	4-6
Shipping Data . . . . .	4-7
Crane Assembly . . . . .	4-13
Remove Protective Covers from Cab Windows . . . . .	4-13
Remove Crane from Trailer . . . . .	4-15
Deploy Operator's Cab . . . . .	4-17
Raise Mast to Operating Position . . . . .	4-17
General . . . . .	4-17
Raising Procedure . . . . .	4-19
Install Assembly Block . . . . .	4-23
Install Crawlers . . . . .	4-25
Deploy Crawler Steps . . . . .	4-29
Install Platforms . . . . .	4-29
Assemble Boom and Jib . . . . .	4-29
Install Counterweight . . . . .	4-31
Assemble Crane Counterweight . . . . .	4-31
Install Carbody Counterweight . . . . .	4-31
Install Crane Counterweight . . . . .	4-33
Install Boom Butt . . . . .	4-37
Lifting Boom Butt . . . . .	4-37
Connect Boom Butt to Crane . . . . .	4-39
Raise Boom Butt Wire Rope Guide . . . . .	4-39
Remove Assembly Block . . . . .	4-41
Connect Boom Butt to Boom . . . . .	4-41
Pre-Raising Checks . . . . .	4-44
Crane Disassembly . . . . .	4-44
Lower Boom and Jib to Ground . . . . .	4-44
Disconnect Boom Butt from Boom . . . . .	4-47
Remove Boom Butt . . . . .	4-51
Remove Counterweight . . . . .	4-53
Remove Crane Counterweight . . . . .	4-53
Remove Carbody Counterweights . . . . .	4-57



Disassemble Crane Counterweight . . . . .	4-57
Disassemble Jib and Boom . . . . .	4-57
Remove Platforms . . . . .	4-57
Remove Crawlers . . . . .	4-59
Remove Assembly Block . . . . .	4-63
Lower Mast to Transport Position . . . . .	4-63
Install Protective Covers on Cab Windows . . . . .	4-65
Store Operator's Cab . . . . .	4-65
Install Crane on Trailer . . . . .	4-67
Boom Ladder . . . . .	4-68
General . . . . .	4-68
Removing Ladders from Storage . . . . .	4-68
Using Ladders . . . . .	4-69
Storing Ladders . . . . .	4-69
Boom and Jib Rigging . . . . .	4-69
Assist Crane Requirements . . . . .	4-69
Blocked Crawlers . . . . .	4-69
Handling Components . . . . .	4-70
Assembly Drawings . . . . .	4-70
Identifying Boom and Jib Components . . . . .	4-71
Boom Installation – #76 . . . . .	4-75
General . . . . .	4-75
Assemble Boom Sections . . . . .	4-75
Raise Auxiliary Drum Wire Rope Guide . . . . .	4-75
Install Upper Boom Point . . . . .	4-75
Connect Boom Straps . . . . .	4-75
Install Intermediate Suspension . . . . .	4-77
Replace Load Pins for Duty-Cycle Operation . . . . .	4-78
Raise Boom Top Wire Rope Guide . . . . .	4-78
Remove Lower Boom Point Sheaves . . . . .	4-78
Install Jib . . . . .	4-78
Install Pile Driver Adapter . . . . .	4-79
Install Clamshell Wire Rope Guide . . . . .	4-79
Connect Boom Butt to Boom . . . . .	4-79
Install Load Line . . . . .	4-79
Install Block-Up Limit Control and Connect Boom Wiring . . . . .	4-81
Boom Removal . . . . .	4-85
Lower Boom and Jib to Ground . . . . .	4-85
Store Load Lines . . . . .	4-85
Remove Block-Up Limit Control and Disconnect Boom Wiring . . . . .	4-85
Disconnect Boom Butt From Boom . . . . .	4-85
Disassemble Boom Sections . . . . .	4-85
Lower Boom Point Assembly . . . . .	4-89
General . . . . .	4-89
Removing and Installing Sheave Clusters . . . . .	4-89
Greasing Sheave Bearings . . . . .	4-89
Adjusting Bearing Side Play . . . . .	4-89
Jib Installation – #134 . . . . .	4-91
General . . . . .	4-91
Prepare Boom . . . . .	4-91
Install Butt . . . . .	4-91
Install Inserts . . . . .	4-91
Install Top . . . . .	4-91
Install Jib Pendants . . . . .	4-93
Install Backstay Pendants . . . . .	4-93
Install Jib Offset Links or Pendants . . . . .	4-93
Connect Jib Backstay Pendants . . . . .	4-93

Install Jib Stop .....	4-95
Install Load Line .....	4-95
Install Block-Up Limit Control and Connect Jib Wiring .....	4-95
Jib Removal – #134 .....	4-96
Lower Boom and Jib .....	4-96
Store Jib Stop .....	4-96
Lower Strut .....	4-96
Remove Backstay Pendants .....	4-96
Remove Jib Pendants .....	4-96
Remove Jib Sections .....	4-97
Pile Driver Adapter Installation .....	4-97
Installation .....	4-97
Operating Specifications With #76 Top .....	4-97
Wire Rope Installation .....	4-98
Wire Rope Storage .....	4-98
Removing Wire Rope from Shipping Reel .....	4-98
Seizing and Cutting Wire Rope .....	4-98
Anchoring Wire Rope to Drum .....	4-99
Winding Wire Rope onto Drum .....	4-101
Anchoring Wire Rope to Socket and Wedge .....	4-102
Anchoring Wire Rope to Button Socket .....	4-104
Breaking in Wire Rope .....	4-104
Pad Eye Usage for Wire Rope Reeving .....	4-104
General .....	4-104
Safety .....	4-104
Load Line Reeving .....	4-107
Wire Rope Specifications .....	4-107
Wire Rope Installation .....	4-107
Liftcrane .....	4-107
Reeving Diagrams .....	4-107
Dead-End Locations – Lower Boom Point .....	4-107
Guide Sheave Identification .....	4-107
Load Blocks .....	4-107
Load Block Tieback .....	4-119
General .....	4-119
Specifications .....	4-119
Shackle .....	4-119
Sling Length .....	4-119
Sling Capacity .....	4-119
Boom Hoist Reeving .....	4-119
Wire Rope Installation .....	4-119

14001060

**THIS PAGE INTENTIONALLY LEFT BLANK**

14001060



## SECTION 4

### SETUP AND INSTALLATION

#### BOOM AND JIB ASSEMBLY DRAWINGS

Boom and jib assembly drawings that apply to your crane are located at the end of this section.

#### LIFTCRANE MAST CAPACITIES

Lifting capacities for the live mast are located at the end of this section.

#### OPTIONAL ATTACHMENTS

If applicable, instructions for optional attachments that apply to your crane are located at the end of this section.

#### GENERAL SAFETY

To prevent accidents that can result in death or injury during crane assembly and disassembly, comply with following general safety information and with specific safety information contained in assembly and disassembly steps.



#### WARNING

##### Avoid Death or Serious injury!

Read and understand setup and installation instructions in this section before attempting to assemble or disassemble crane.



#### WARNING

##### Tipping/Overload Hazard!

Prevent crane from tipping over and live mast from collapsing:

- Assemble and disassemble crane on a firm uniformly supporting surface that is level to within 1% grade — 1 ft (0,3 m) in 100 ft (30,5 m)
- Do not exceed swing limits and mast lifting capacities given in [Table 4-2](#)
- Do not allow crane to go more than 3° out of level when operating carbody jacks



#### WARNING

##### Avoid Falling Off Crane and Boom!

It is necessary to climb onto crane and boom during assembly and disassembly steps.

Use sturdy owner furnished ladders or an approved personnel hoist to gain access to areas which cannot be reached from ladders or steps provided with crane.



#### WARNING

##### Moving Parts/Pinch Points!

Avoid death or crushing injury during crane assembly and disassembly:

- Assembly personnel — take every precaution to prevent injury when working near moving parts
- Maintain communication between operator and assemblers to avoid accidents
- Do not raise or lower gantry or live mast until all personnel are off crane
- Keep unauthorized personnel well clear of crane



#### WARNING

##### Falling Load Hazard!

Prevent lifting equipment from failing and load from dropping, crane owner/user shall verify following prior to each lift:

- All lifting equipment (shackles, hooks, slings, blocks) has been properly maintained and is safe for use
- All lifting equipment has a capacity equal to or greater than load to be lifted

#### CRANE ORIENTATION

The terms RIGHT, LEFT, FRONT, and REAR used in this section refer to the operator's right, left, front, and rear sides when seated in the operator's cab looking forward:

- The operator's cab is at the FRONT of the rotating bed.
- The crawler remote controls are on the FRONT of the carbody.
- When the upperworks and lowerworks are both facing forward, the left crawler motor is at the REAR and the right crawler motor is at the FRONT.

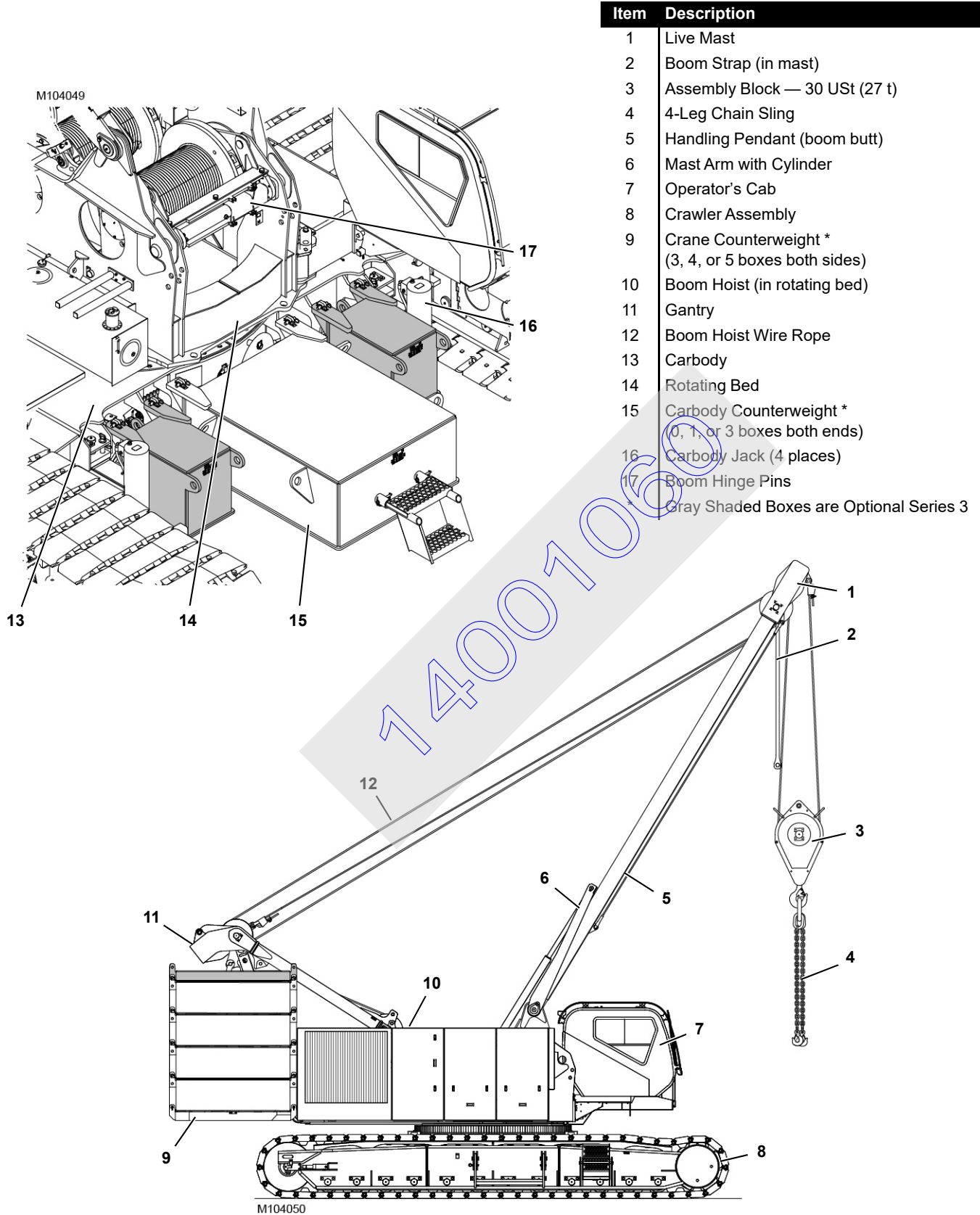


FIGURE 4-1

## SELF-ERECTING EQUIPMENT

The 14000 is equipped with the following self-erect components for assembly and disassembly (see [Figure 4-1](#)):

- Carbody jacks with pads for lifting the crane onto and off a trailer. The jacks are controlled by handles on front of the carbody.
- Hydraulically actuated pins for connecting and disconnecting the crawlers to and from the carbody. The pins are controlled by handles on front of the carbody.
- Hydraulic cylinders for raising and lowering the gantry. The cylinders are controlled by switches on a remote control.
- Hydraulically actuated pins for engaging and disengaging the gantry backhitch pins. The pins are controlled by switches on a remote control.
- Hydraulically actuated mast arms for raising the mast to the operating position and lowering it to the transport position. The arms are controlled by a switch on the overhead console in the operator's cab.
- Mast which can be used as a boom to handle the crane's crawlers and counterweights and to assemble and disassemble the boom and jib. The mast is controlled by the boom hoist control handle in the operator's cab.
- Hydraulically actuated pins for connecting the boom butt to the rotating bed. The pins are controlled by a switch on the overhead console in the operator's cab.
- Assembly block — 30 USt (27 t) — and 4-leg chain sling with hooks for handling components

## ASSEMBLY AND DISASSEMBLY NOTES

The crane, boom, and jib shall be assembled and disassembled by experienced personnel trained in erection and operation of construction cranes.

Before attempting to assemble, operate, or disassemble the crane, read and become thoroughly familiar with the instructions in this section and in the boom and jib assembly drawings at end of this section.

Contact your Manitowoc dealer for assistance if any procedure is not fully understood.

## ASSEMBLY AND DISASSEMBLY AREA

Select an assembly/disassembly area that has a firm, level, uniformly supporting surface. Make sure the area is large enough to accommodate the crane and the selected boom length, movement of trucks with trailers, and movement of an assist crane (if used).

Set the jack pads on a flat, firm foundation that will support the load placed on them. See [Table 4-1](#) for loadings.

Do not set the jack pads in holes, on rocky ground, or on extremely soft ground. **Jack pads could break.**

If necessary, use wood blocking or steel plates under the jack pads to properly distribute loading and to provide a smooth surface ([Figure 4-2](#)). The wood blocking or steel plates must be:

- Free of defects
- Strong enough to prevent being crushed or bent
- Of sufficient length and width to prevent settling under load

Contact your Manitowoc dealer for ground bearing information.

**Table 4-1**  
Load Data for Carbody Jacks

Maximum Load on each Jack — 72,000 (32 659 kg)
Jack Pad Diameter — 24 in (610 mm)
Jack Pad Weight — 50 lb (23 kg)



**FIGURE 4-2**

## ACCESSING PARTS

Some parts of the crane, boom, and jib cannot be reached from the ground. Take necessary precautions to prevent slipping and/or falling off the crane or boom during assembly, disassembly, maintenance, or other work. **Falling from any height could result in serious injury or death.**

Owner/user shall provide workers with approved ladders or aerial work platforms to access those areas of the crane, mast, boom, and jib that cannot be reached from the ground or from steps, ladders, catwalks, and platforms provided by Manitowoc.

Adhere to local, state, and federal regulations for handling personnel and for personnel fall protection.

**Do not use top of mast, boom inserts, and boom top as walkways.**

Catwalks and platforms are provided on the boom butt for accessing the boom butt wire rope guide.

Optional boom ladders are available from Manitowoc. If your crane has ladders, see the instructions on [Page 68](#).

**CRANE WEIGHTS**

See Crane Weights in Section 1 and Shipping Data on [Page 7](#) for overall weight of the crane and individual weights of components.

**HANDLING COMPONENTS**

The major components are equipped with lifting lugs which are identified in the assembly and disassembly steps.

When lifting lugs are not provided, use nylon lifting slings. If wire rope or chain slings are used, install protective covering (such as sections of rubber tire) between slings and component being lifted.

**CAUTION**

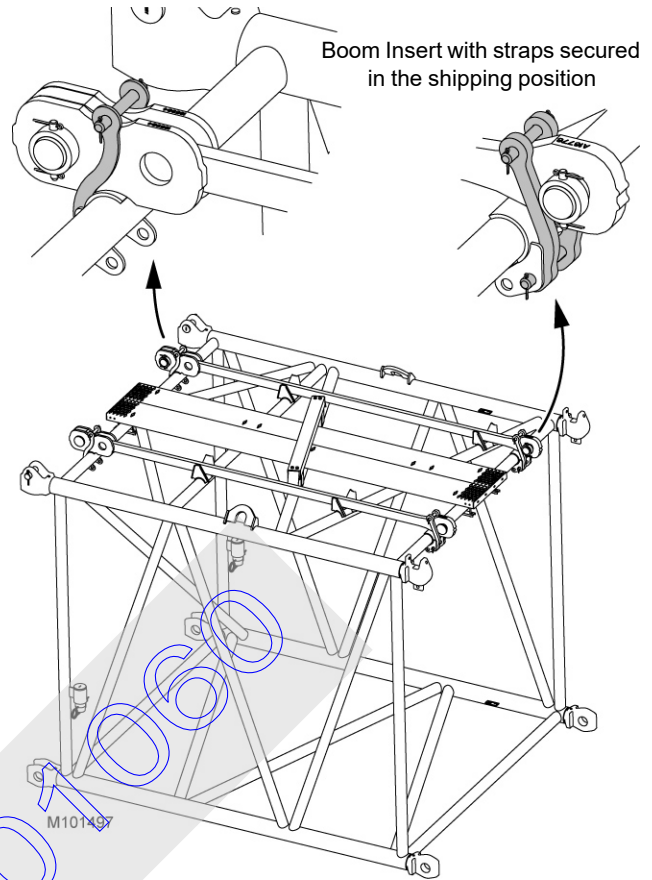
**Lacing Damage!**

Ensure straps for boom inserts and top remain pinned and secured in the shipping position during handling and transportation unloading.

**CAUTION**

**Personal Injury or Property Damage!**

Ensure the boom straps remain properly secured in the shipping position to the boom insert or boom top during transportation loading or unloading and assembly or disassembly of the boom. Straps could shift or fall resulting in personal injury or property damage if not properly secured.



Boom Insert with straps secured in the shipping position

*It is the owner/user's responsibility to ensure that all lifting slings, hooks, and shackles are in safe working order and capable of handling loads applied to them.*

**RETAINING CONNECTING PINS**

Connecting pins are retained in various ways:

- Snap pins
- Quick-release pins
- Cotter pins
- Keeper plates with cap screws and lock washers

Do not operate crane until all connecting pins are installed and properly retained.

### COLD WEATHER MAST OPERATION

The live mast, live mast cylinders, and mast arms can be damaged when attempting to lower the live mast (to rear) during cold weather.

Do not attempt to lower the live mast with the mast hoist during cold weather until the following steps have been performed:

- Hydraulic oil warmed to at least 60°F (16°C)
- Mast cylinders fully extended and retracted twice to fill cylinders with warm oil

### SHIPPING CRANE COMPONENTS

To ensure the crane's self-erecting system can load and unload the carbody and upperworks assembly, the trailer must meet the specifications given in [Figure 4-6](#).

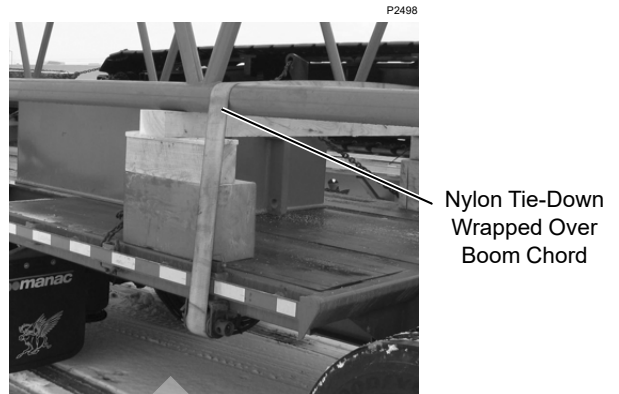
It is the owner/user's responsibility to ensure the following:

- All trailer loads comply with local, state, and federal transportation requirements.
- **All crane components are properly blocked and secured so they cannot shift or fall off trailers.**
- To avoid damage to components:

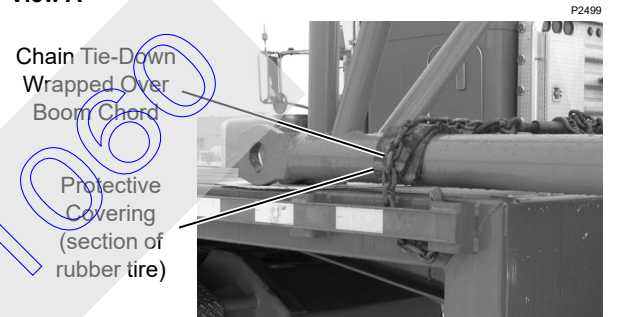
Use nylon tie-downs to secure components as shown in [Figure 4-3](#), View A.

If chain tie-downs are used, install protective covering (such as sections of rubber tire) between the chain and component being secured as shown in [Figure 4-3](#), View B.

When securing boom sections, wrap tie-downs over chords — never over lacings. Keep tie-downs as close to blocking as possible (View A) to prevent bending the chords.



View A



View B

FIGURE 4-3

14001088



## OPERATING CONTROLS

To assemble and disassemble the 14000 with the self-erecting system, the engine must be running and LIFTCRANE MAST CAPACITIES CHART must be selected in the configuration screen of the Rated Capacity Indicator/Limiter (Figure 4-4).

The setup mode icon (Figure 4-5) will appear in the fault area of the information screen and the fault alarm will beep on and off (beep-beep-beep...).

See Section 3 for remote control operating instructions.

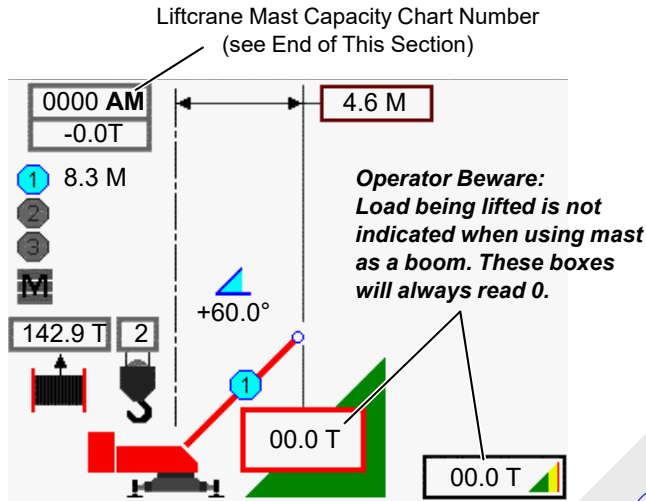


FIGURE 4-4

14COM4102

14COM4102a

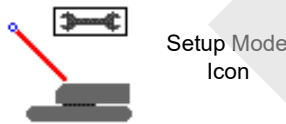


FIGURE 4-5

The crane's programmable controller automatically increases engine speed to approximately 1,300 RPM (if engine is running slower) when any accessory function is operated. If engine speed is set higher than 1,300, the existing speed is maintained. The accessory functions are:

- Carbody Jacks
- Crawler Pins
- Gantry Cylinders
- Mast Arm Cylinders
- Boom Hinge Pins
- Cab Tilt Cylinder

## PRE-START CHECKS

Make the following checks before starting the engine upon arrival at the assembly site. See Section 3 for starting instructions.

### Engine

1. Check for leaks.
2. Check fuel, oil, and coolant levels.
3. Repair or refill as required.

### Gear Boxes

1. Check for leaks.
2. Check gear box reservoir level.
3. Repair or refill as required.

### Hydraulic System

1. Check for leaks.
2. Check hydraulic reservoir level.
3. Repair or refill as required.
4. Make sure hydraulic shut-off valve is open.

### Electric System

Check that electric cable (2a, View B, Figure 4-8) is connected to terminating plug (1).

If equipped with a boom butt drum with bail limit, make sure terminating plug (1, View C, Figure 4-8) is connected to electric cable (2b).

The crane's controls may not operate properly and faulty readings may appear on the main display if this step is not performed.



## WARNING

### Burn and Inhalation Hazards!

Temperature of exhaust and exhaust components for Tier 4 engines can be higher than other engines.

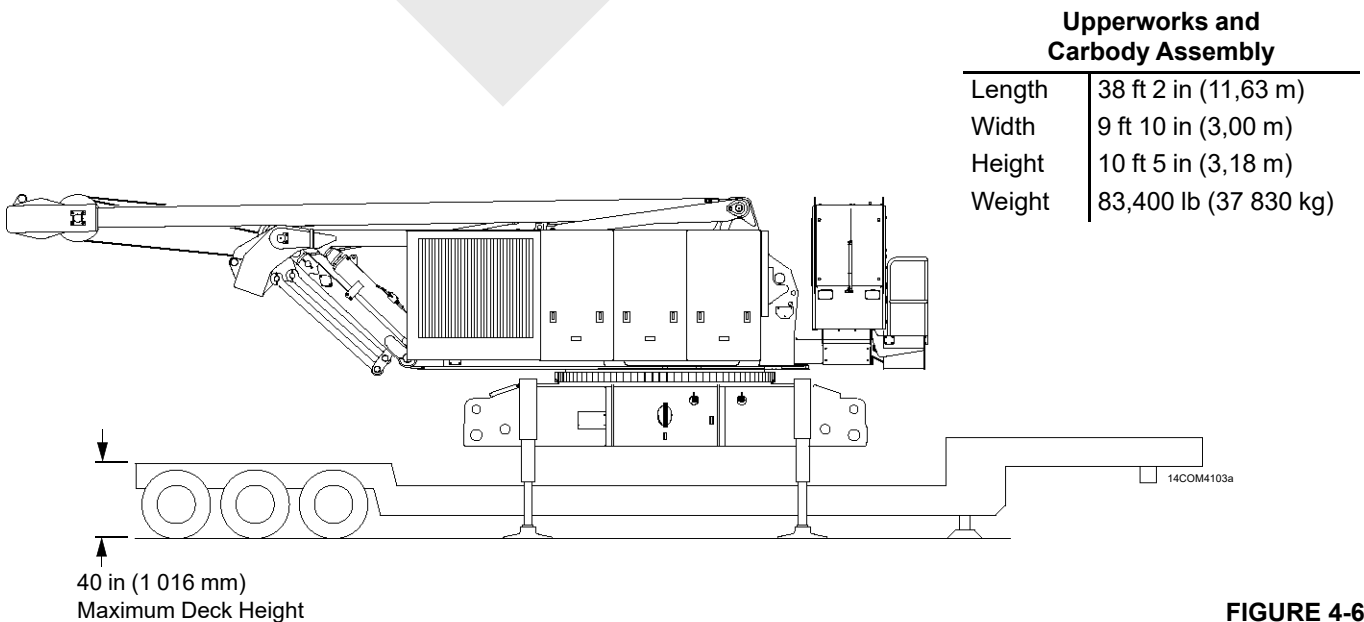
To prevent death or serious injury:

- Avoid physical contact with exhaust gases and exhaust system components
- Keep all flammable materials away from the exhaust system to prevent fire
- If necessary to service crane while engine is running, inhibit (turn off) DPF regeneration using switch in cab to prevent higher exhaust temperatures

**Table 4-2**  
Operating Limitations During Crane Assembly and Disassembly

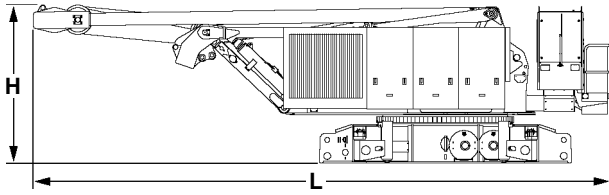
Crane Configuration	Operating Limitations
Crane on Jacks Gantry and Mast in Transport Position No Counterweight Installed	360° Swing Permitted
Crane on Jacks Gantry UP Mast at Maximum Angle of 172° No Counterweight Installed	360° Swing Permitted
Crane on Jacks Gantry UP Mast at Maximum Angle of 145° Chain Sling and Assembly Block Installed No Counterweight Installed	360° Swing Permitted
Crane on Jacks Gantry UP Installing Crawlers with Mast No Counterweight Installed	<ul style="list-style-type: none"> <li>• 15° Maximum Swing either Side of Center (see <a href="#">Figure 4-13</a>) while handling a crawler</li> <li>• 15 ft (4,6 m) Maximum Radius</li> <li>• Mast at 118° or higher before swinging after first crawler is installed</li> </ul>
Crane on Crawlers Gantry UP Handling Loads with Mast Counterweight Installed (Series 1, 2, 3)	<ul style="list-style-type: none"> <li>• See <b>Liftcrane Mast Capacities chart at end of this section for lifting capacities</b></li> </ul>
Crane on Crawlers Gantry DOWN Mast DOWN Counterweight Installed (Series 1, 2, 3)	360° Swing Permitted

**SHIPPING DATA**



**FIGURE 4-6**



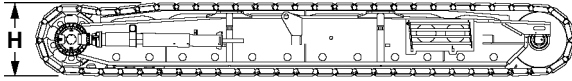


**Upperworks and Carbody Assembly**

Length	38 ft 4 in <sup>1</sup>	11,7 m
	38 ft 8 in <sup>2</sup>	11,8 m
Width	9 ft 10 in	3,0 m
Height	10 ft 5 in	3,2 m
Weight	83,400 lb	37 830 kg

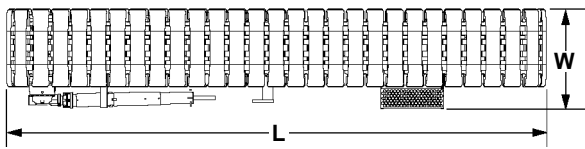
<sup>1</sup> with 20 in (508 mm) Wide Cab Catwalk

<sup>2</sup> with 24 in (610 mm) Wide Cab Catwalk



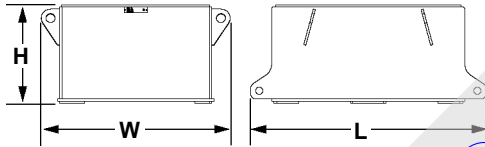
**Crawlers with Step**

Length	27 ft 3 in	8,3 m
Width	5 ft 1 in	1,6 m
Height	3 ft 8 in	1,1 m
Weight	38,915 lb	17 652 kg



**Center Counterweight Box**

Length	4 ft 3 in	1,3 m
Width	3 ft 5 in	1,0 m
Height	1 ft 10 in	0,6 m
Weight	5,909 lb	2 680 kg



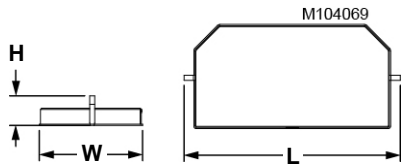
**Side Counterweight Box (Series 1, 2, 3)**

Length	7 ft 4 in	2,3 m
Width	3 ft 6 in	1,1 m
Height	2 ft 3 in	0,7 m
Weight	17,650 lb	8 006 kg



**Side Counterweight Box (Series 3)**

Length	7 ft 4 in	2,3 m
Width	3 ft 6 in	1,1 m
Height	1 ft 0 in	0,3 m
Weight	5,000 lb	2 268 kg



**Counterweight Tray**

Length	12 ft 2 in	3,7 m
Width	7 ft 9 in	2,4 m
Height	1 ft 1 in	0,3 m
Weight	21,240 lb	9 634 kg

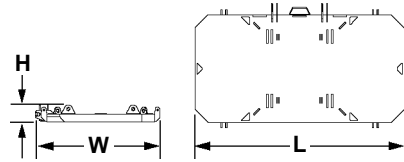
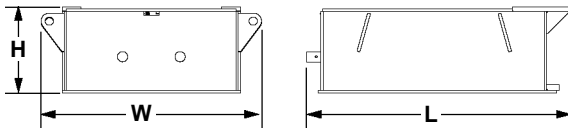
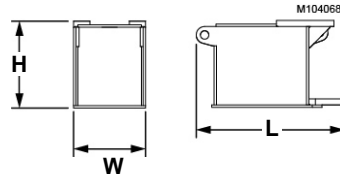


FIGURE 4-6 continued



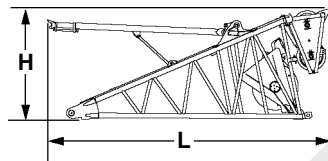
**Carbody Counterweight (Series 2, 3)**

Length	7 ft 4 in	2,2 m
Width	6 ft 1 in	1,9 m
Height	2 ft 5 in	0,7 m
Weight	26,500 lb	12 020 kg



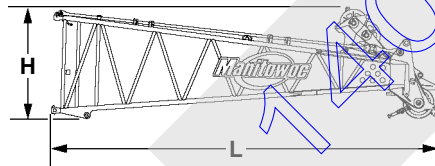
**Carbody Counterweight (Series 3)**

Length	7 ft 4 in	2,2 m
Width	6 ft 1 in	1,9 m
Height	2 ft 5 in	0,7 m
Weight	26,500 lb	12 020 kg



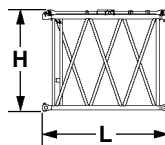
**No. 76 Boom Butt 18 ft (5,5 m) Wire Rope Guide & Straps**

Length	22 ft 2 in	6,8 m
Width	8 ft 0 in	2,4 m
Height	8 ft 8 in	2,6 m
Weight	6,240 lb	2 830 kg



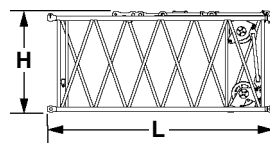
**No. 76 Boom Top 30 ft (9,0 m) Wire Rope Guide & Straps**

Length	31 ft 5 in	9,6 m
Width	8 ft 3 in	2,5 m
Height	9 ft 9 in	3,0 m
Weight	9,850 lb	4 468 kg



**No. 76 Main Boom Insert 10 ft (3,0 m) & Straps**

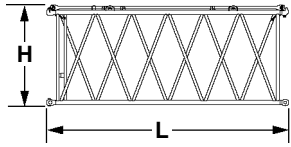
Length	10 ft 5 in	3,2 m
Width	8 ft 4 in	2,5 m
Height	8 ft 6 in	2,6 m
Weight	2,650 lb	1 202kg



**No. 76 Main Boom Insert 18 ft (5,5m) with Auxiliary Sheaves & Straps**

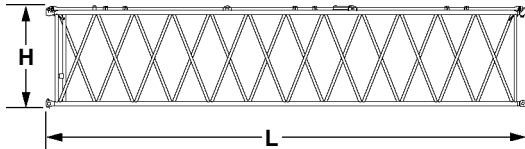
Length	18 ft 8 in	5,7 m
Width	8 ft 4 in	2,5 m
Height	8 ft 6 in	2,6 m
Weight	3,570 lb	1 619 kg

FIGURE 4-6 continued



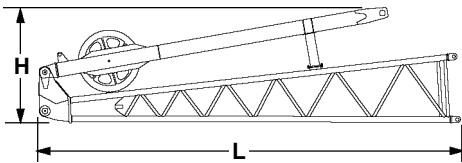
**No. 76 Main Boom Insert 20 ft (6,0 m) & Straps**

Length	20 ft 3 in	6,2 m
Width	8 ft 4 in	2,5 m
Height	8 ft 6 in	2,6 m
Weight	2,670 lb	1 211 kg



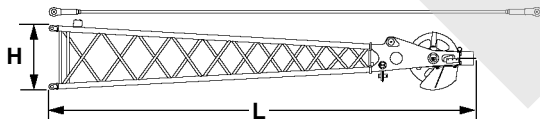
**No. 76 Main Boom Insert 40 ft (12,0 m) & Straps**

Length	39 ft 11 in	12,2 m
Width	8 ft 4 in	2,5 m
Height	8 ft 6 in	2,6 m
Weight	4,610 lb	2 091 kg



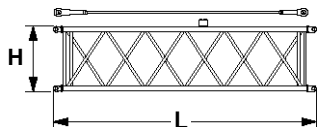
**No. 134 Jib Butt 15 ft (4,6 m) with Strut & Stop**

Length	15 ft 4 in	4,7 m
Width	2 ft 10 in	0,9 m
Height	4 ft 3 in	1,3 m
Weight	1,400 lb	635 kg



**No. 134 Jib Top 15 ft (4,6 m) with Pendants**

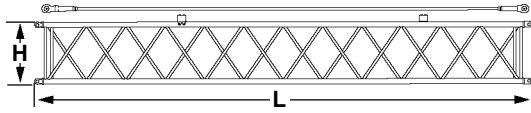
Length	16 ft 2 in	4,9 m
Width	2 ft 7 in	0,8 m
Height	2 ft 7 in	0,8 m
Weight	1,220 lb	553 kg



**No. 134 Jib Insert 10 ft (3,0 m) with Pendants**

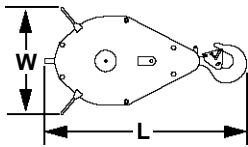
Length	10 ft 3 in	3,1 m
Width	2 ft 7 in	0,8 m
Height	2 ft 7 in	0,8 m
Weight	480 lb	218 kg

FIGURE 4-6 continued



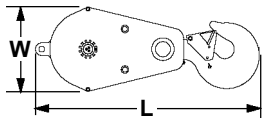
**No. 134 Jib Insert 20 ft (6,0 m) with Pendants**

Length	20 ft 3 in	6,2 m
Width	2 ft 7 in	0,8 m
Height	2 ft 7 in	0,8 m
Weight	750 lb	340 kg



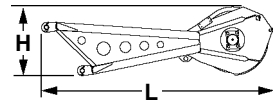
**Hook Block 30 t (27 mt) for 1 in (26 mm) Wire Rope**

Length	5 ft 11 in	1,8 m
Width	3 ft 2 in	1,0 m
Depth	0 ft 10 in	0,3 m
Weight	1,500 lb	680 kg



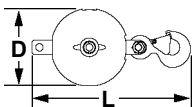
**Hook Block 220 t (200 mt) for 1 in (26 mm) Wire Rope**

Length	7 ft 6 in	2,3 m
Width	2 ft 9 in	0,8 m
Depth	2 ft 10 in	0,9 m
Weight	5,450 lb	2 034 kg



**Upper Boom Point Assembly**

Length	8 ft 10 in	2,7 m
Width	1 ft 10 in	0,6 m
Height	2 ft 8 in	0,8 m
Weight	1,098 lb	498 kg



**Hook and Weight Ball 15 t (13,6 mt)**

Capacity/Swivel	15 t	13,6 mt
Diameter	1 ft 10 in	0,6 m
Length	3 ft 9 in	1,2 m
Weight	1,310 lb	594 kg

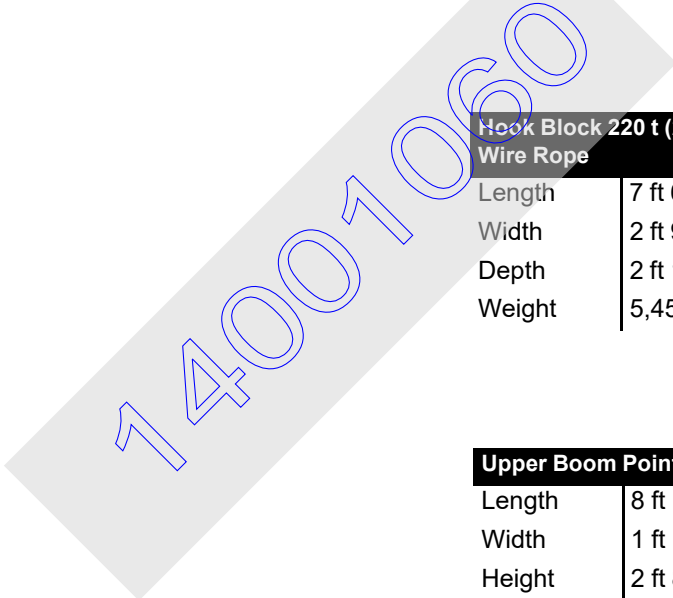


FIGURE 4-6 continued

**THIS PAGE INTENTIONALLY LEFT BLANK**

14001060

## CRANE ASSEMBLY

### Remove Protective Covers from Cab Windows

If equipped, remove and store optional protective covers from windows of operator's cab (see [Figure 4-7](#)).

14COM4195

Past Production Cab Shown. Current Production Cab Similar.

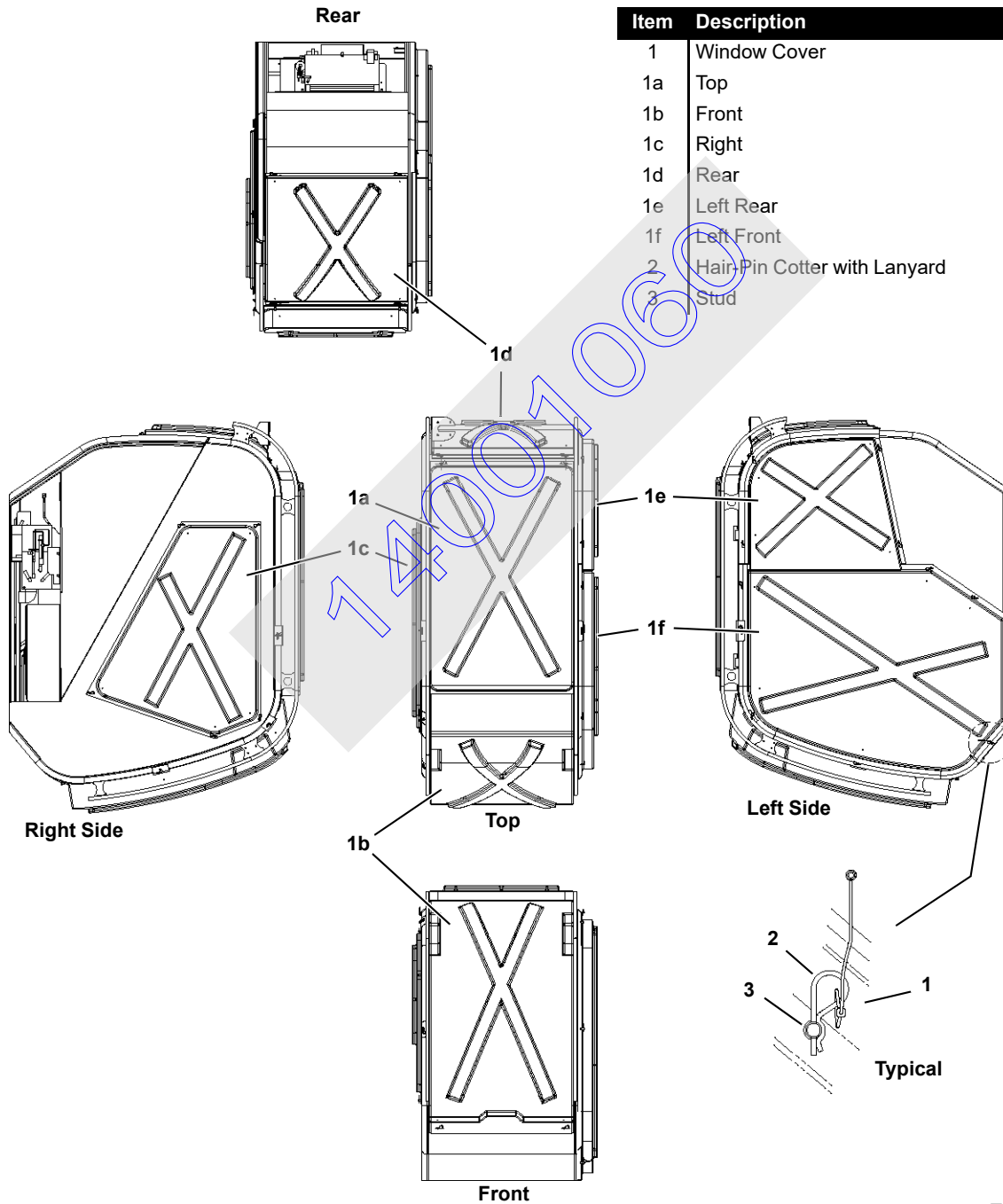
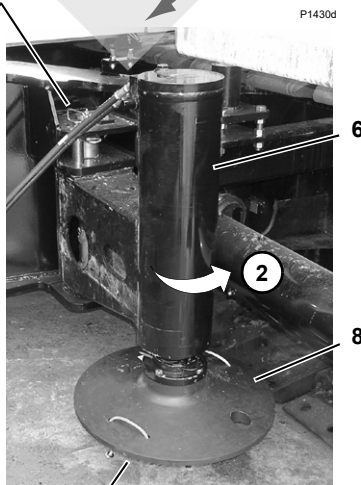
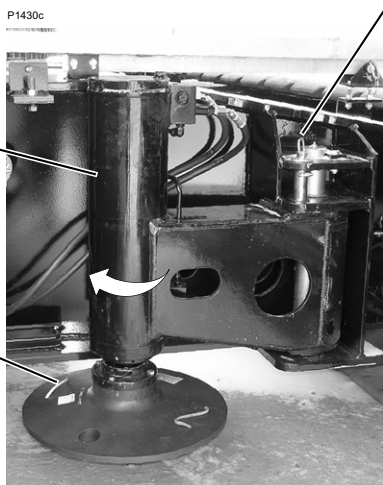
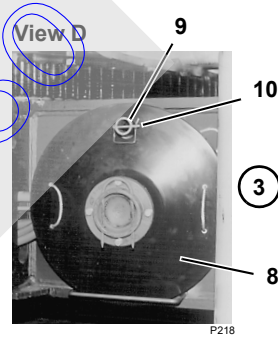
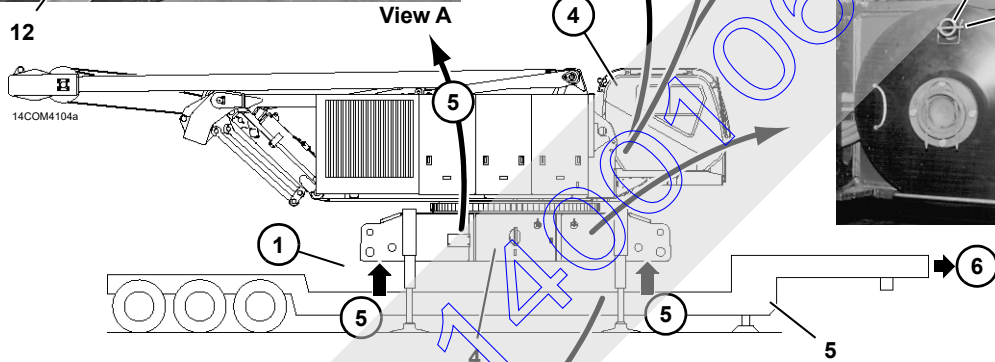
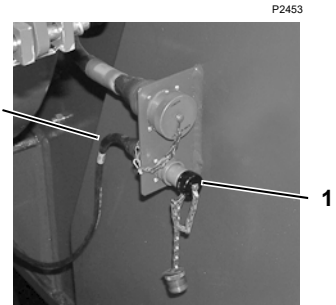
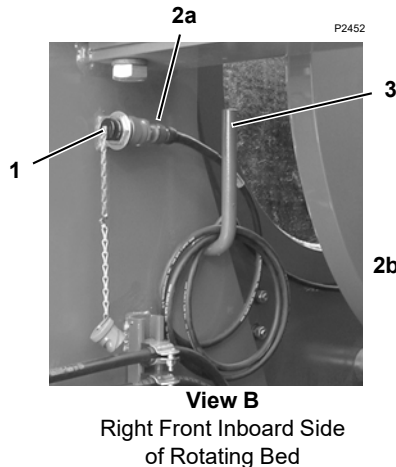
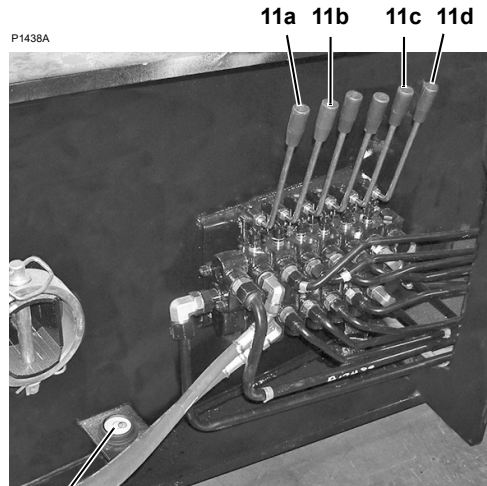


FIGURE 4-7

Circled Numbers Correspond to REMOVE CRANE FROM TRAILER Procedure



If necessary, block under jack pads to provide a firm, smooth foundation (see Figure 4-2).

Item	Description
1	Terminating Plug with Dust Cap
2a	Electric Cable WBC
2b	Electric Cable W33J1
3	Bracket
4	Carbody
5	Trailer
6	Carbody Jack (4 places)
7	Hitch Pin with Hair-Pin Cotter
8	Jack Pad with U-Shaped Pin
9	Storage Lug
10	Snap Pin
11a	Right Front Carbody Jack Control
11b	Right Rear Carbody Jack Control
11c	Left Rear Carbody Jack Control
11d	Left Front Carbody Jack Control
12	Level

FIGURE 4-8



## Remove Crane from Trailer

See [Figure 4-8](#) for the following procedure.



### WARNING

#### Moving Part Hazard!

Avoid serious crushing injury:

- Warn all personnel to stand clear of jacks

#### Tipping Hazard!

Avoid tipping crane over:

- Keep crane level while jacking

1. Untie carbody (4) from trailer (5).
2. Position each carbody jack (6) as follows:
  - a. Remove hitch pin (7, View E).
  - b. Swing jack out (View F).
  - c. Install hitch pin (7, View F).

3. Remove jack pads (8, View D) from storage and connect to jack rods with U-shaped pins (View F).
4. Perform pre-start checks and start engine.

**NOTE:** It is normal for faults (engine and hydraulic) to come on when the engine is started.

The faults should go off as engine oil pressure and hydraulic oil temperature rise to normal. If faults do not go off soon after start-up, determine fault, stop engine, and correct cause (see Main Display instructions in Section 3).

5. Using controls (11, View A) on front of carbody, extend carbody jacks fully to raise crane off trailer.

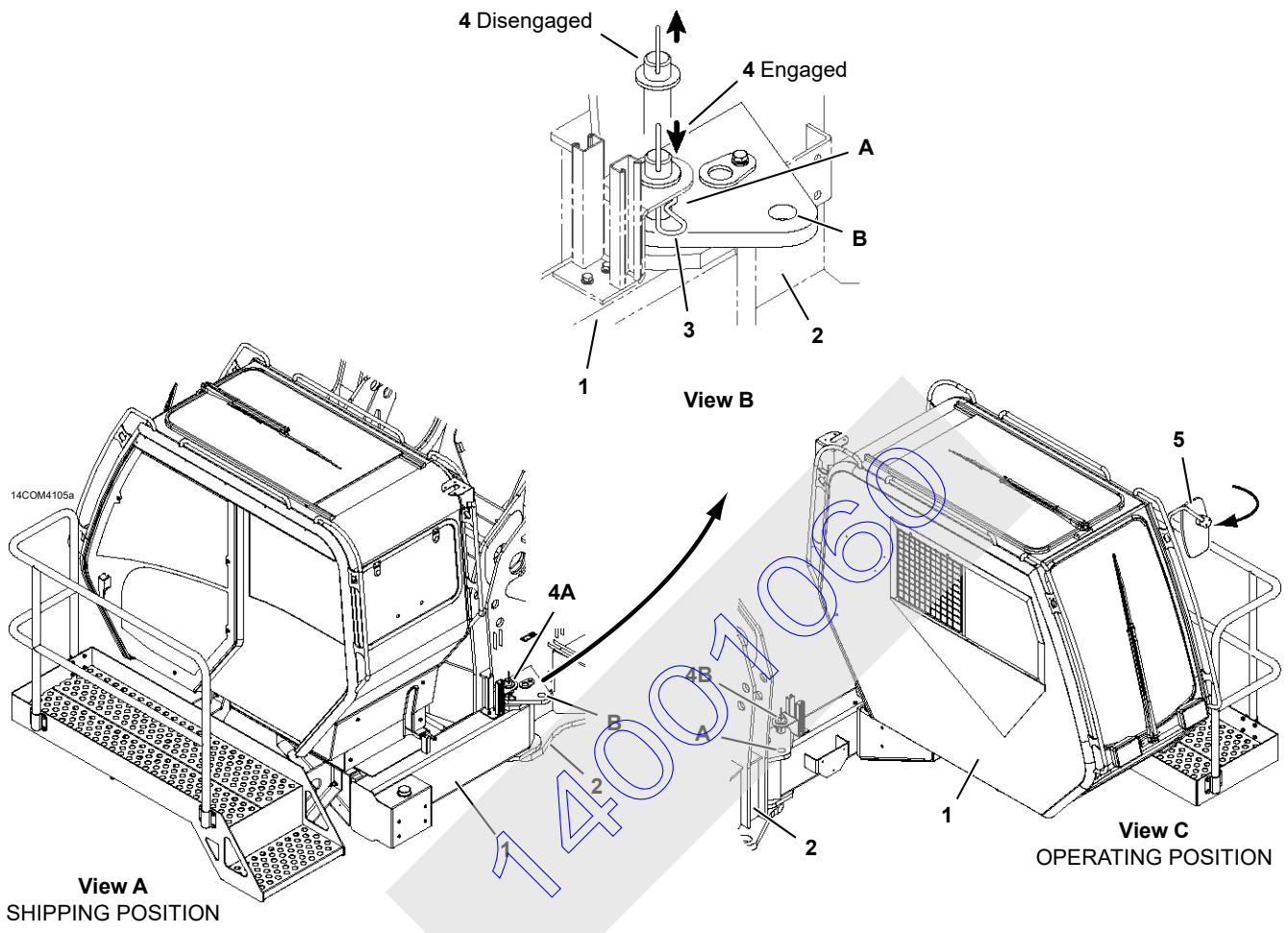
**NOTE:** Level (12) is provided near controls.

6. Slowly pull trailer out from under crane.
7. Retract jacks (keep crane level) until carbody is approximately 2 ft (0,6 m) above ground.

#### OPERATING NOTE

360° swing is permitted when crane is on jacks with gantry and mast in transport position.

140010600



Item	Description
1	Operator's Cab
2	Rotating Bed
3	Hair-Pin Cotter
4	Hitch Pin
5	Mirror
A	Shipping Hole
B	Operating Hole

Past Production Cab Shown. Current Production Cab Similar.

FIGURE 4-9

## Deploy Operator's Cab

See [Figure 4-9](#) for the following procedure.

Rotate operator's cab (1) to operating position as follows:

1. Remove hair-pin cotter (3, View B) from top retaining hole in hitch pin (4).
2. Raise hitch pin (4, View B) to disengaged position (bottom retaining hole visible) and reinstall hair-pin cotter (3).
3. Rotate cab (1) 90° to operating position (View C).
4. Remove hair-pin cotter (3, View B) and lower hitch pin (4) to engaged position.
5. Reinstall hair-pin cotter (3, View B).
6. Rotate mirror (5, View C) to operating position.

## Raise Mast to Operating Position

See [Figure 4-10](#) for the following procedure.

### General

The following controls are used to raise the gantry and mast. See Section 3 for identification and operation of these controls.

- MAST ARMS SWITCH in operator's cab to raise and lower the mast arms independently of the mast
- BOOM HOIST CONTROL to raise and lower the mast while using the mast as a boom

- SETUP REMOTE CONTROL to disengage and engage the backhitch pins and to extend and retract the gantry cylinders
- MAIN DISPLAY information screen to monitor the mast operating angle and to identify mast faults

See [Figure 4-10](#) for a list of mast faults.



### DANGER

#### Moving Part/Crush Hazard!

Avoid being crushed by moving parts:

- Do not stand on crane while mast and gantry are being raised

#### Falling Mast Hazard!

Prevent mast from falling over backwards or forward:

- Read and thoroughly understand mast raising instructions
- Select Lifterane Mast Capacities Chart in configuration screen of RCL display before raising mast and using it as a boom. Mast operating limits remain off until this step is performed.

### CAUTION

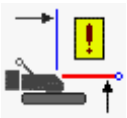
#### Mast Damage!

Prevent damage to mast:

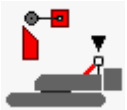
Make sure mast angle indicator is properly installed and calibrated prior to raising gantry and mast. See Service Manual for instructions.

**Mast Faults**

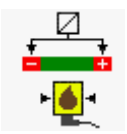
Icons for faults listed below appear in information screen of main display when corresponding limit is reached. See Section 3 for instructions.



**66-MAST TOO FAR FORWARD** — Live mast is below 172°. Raise live mast. Further lowering is not intended. Mast will fall.



**72-GANTRY DOWN** — Limit switch stops boom. Boom is inoperable at all mast angles. Raise gantry.



**41-TRANSDUCER VOLTAGE** — Boom/mast hoist inoperable in both directions. Check that accessory system, Drum 1, and Drum 4 transducers are within allowable range.

Circled Numbers Correspond to  
**RAISE MAST TO OPERATING POSITION**  
Procedure

Item	Description
1	Mast
2	Mast Arm (with hydraulic cylinder) (2)
3	Gantry
4	Backhitch (2)
5	Backhitch Pin (2)
6	Gantry Cylinder (2)
7	Handling Strap (8)
8	Pin with Cotter Pin (2)
9	Storage Link (2)
10	Stud with Cotter Pin (2)

Numbers in parentheses equal quantity

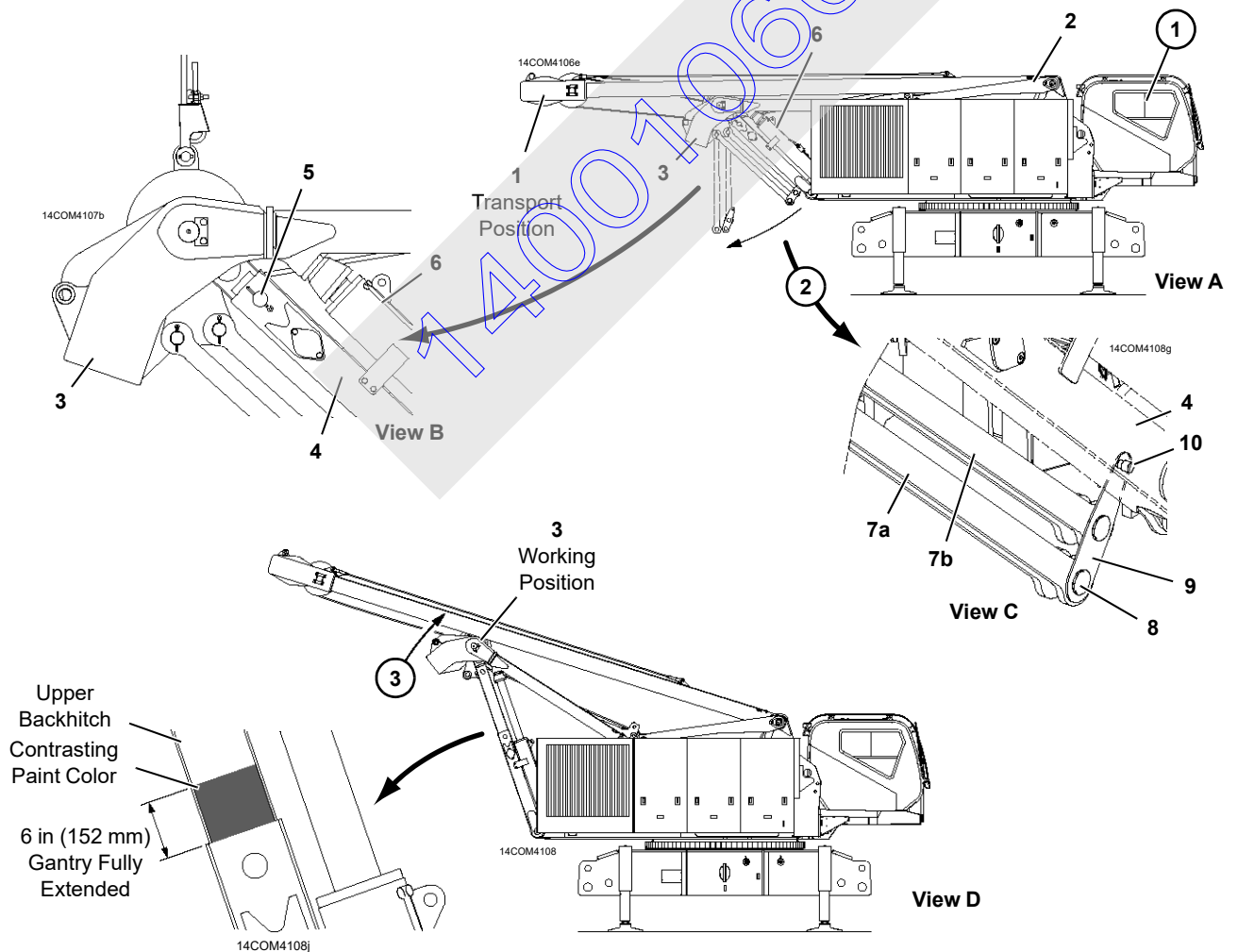


FIGURE 4-10

## Raising Procedure

See [Figure 4-10](#) for the following procedure.

1. Perform the following steps in operator's cab:
  - a. Select Liftcrane Mast Capacities Chart in configuration screen of RCL display.  
The mast and gantry controls will not operate properly and the mast operating limits will remain off until the proper capacity chart is selected.
  - b. During the raising procedure, monitor MAST ANGLE either in the information screen of the main display or in the RCL screen (when mast only chart is selected). Mast angles are measured from the transport position which is  $-0.6^{\circ}$ .
  - c. Turn on setup remote control in function mode screen of main display.
  - d. Turn off boom hoist (Drum 4) park switch.

---

### CAUTION Gantry Damage!

Prevent damage to handling straps or gantry:

Do not raise gantry until handling straps have been disconnected from gantry backhitch.

2. Disconnect counterweight handling straps from gantry backhitch (see View C):
  - a. Support handling straps (7a) so they cannot fall and remove pins (8).

- b. Lower handling straps (7a) to vertical and reinstall pins (8) in holes of handling straps (7a).
- c. Disconnect storage links (9) from studs (10) and lower handling straps (7b) to vertical.
- d. Reinstall cotter pins in studs (10).

**NOTE:** During step 3, the following will occur:

- Mast will rise with gantry
- Boom hoist wire rope will pay out automatically
- Mast arms will remain down

3. Raise gantry (3), as follows:

- a. Remove cotter pins from backhitch pins (5, View B).
- b. Disengage backhitch pins with remote control. Keep pins disengaged until gantry is fully raised.

**Visually check that both backhitch pins are fully disengaged.**

- c. Raise gantry to working position with remote control (View D). backhitch pin holes should be aligned.

The upper backhitches are painted a contrasting color (View B) to indicate when the gantry is fully extended.

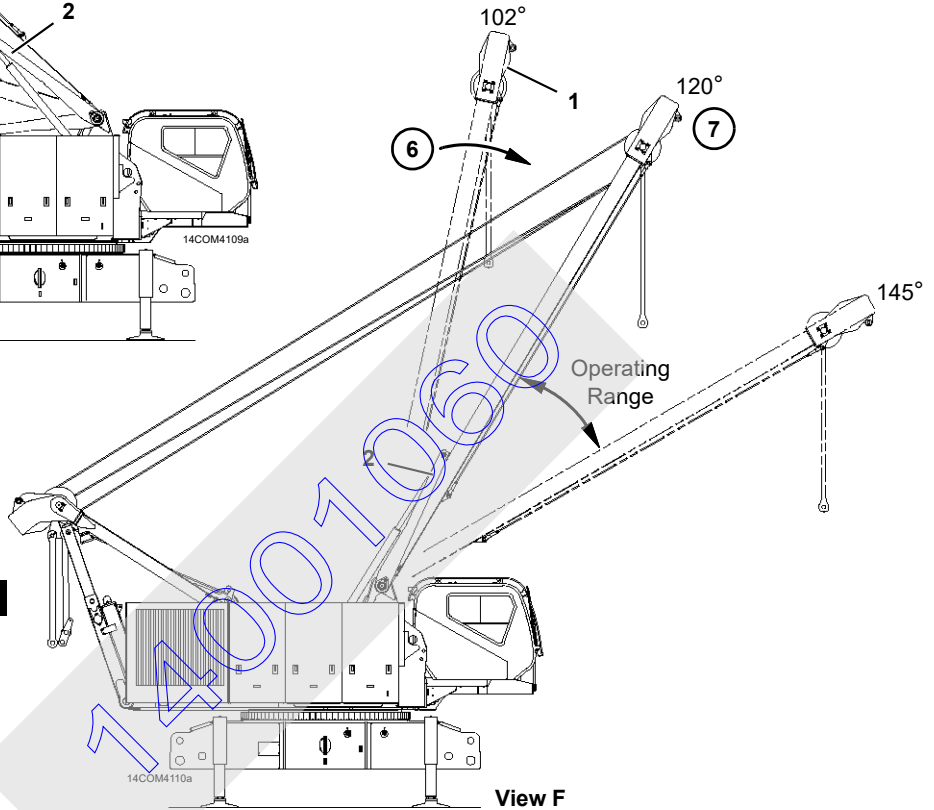
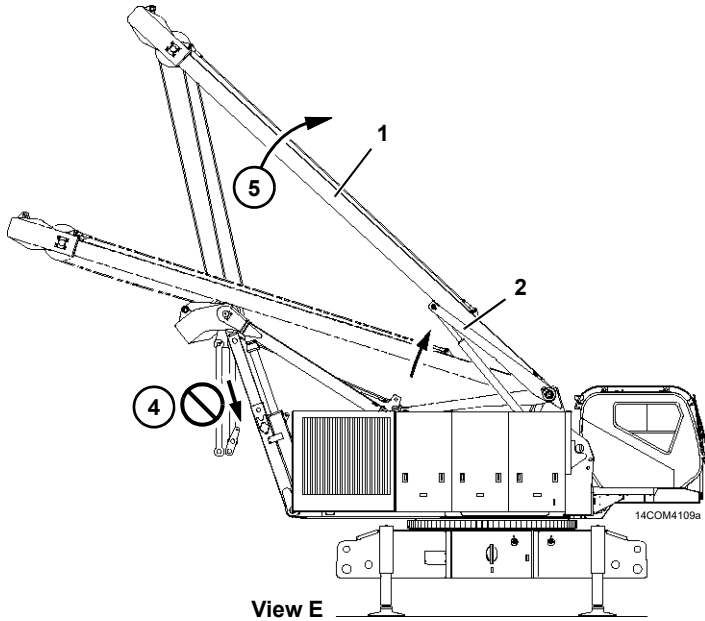
- d. Engage backhitch pins with remote control.

**Visually check that both backhitch pins are fully engaged.**

- e. Install cotter pins in backhitch pins.

Circled Numbers Correspond to  
**RAISE MAST TO OPERATING POSITION**  
Procedure

**NOTE:** Mast must be raised to approximately 102° when installing crawlers and carbody counterweight. Mast arm cylinders will retract automatically as mast is raised and then extend when the mast is lowered.



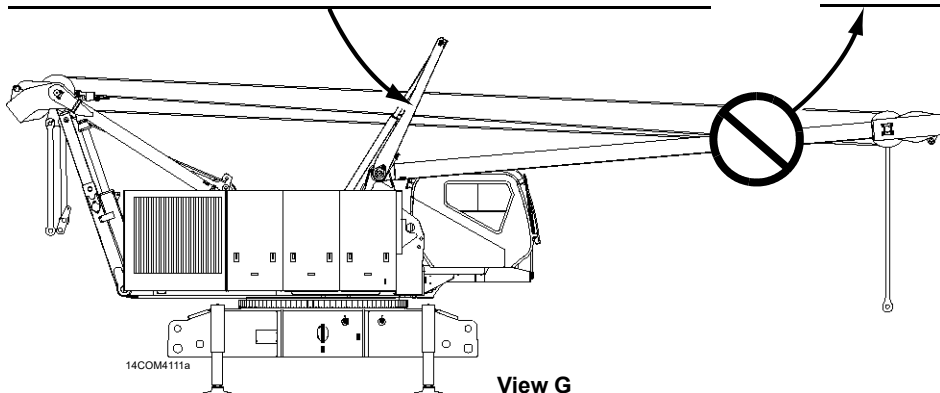
Item	Description
1	Mast
2	Mast Arm (with hydraulic cylinder)

**! DANGER**  
**Falling Mast Hazard!**

Do not lower mast arms until mast is connected to boom rigging. Mast will fall over backwards if raised to vertical when arms are down.

**! DANGER**  
**Falling Mast Hazard!**

Do not use limit bypass to lower mast below 172°. Mast will fall suddenly.



172° — Lower mast to this position only for installing assembly block

FIGURE 4-10 continued

4. Do not retract gantry cylinders at this time. They can remain extended until after the counterweights are installed.
5. BOOM DOWN with boom hoist control to raise mast (1, View E).  
  
The mast arms will rise automatically until they contact the mast. Then, the arms will continue to rise to raise the mast.
6. Continue to raise mast to operating range.
7. Mast arms (2) will stop automatically when cylinders are fully extended (at approximately 120°) (View F).

**NOTE:** Engine speed will decrease if the throttle is set at less than 1,300 RPM.



**DANGER**  
**Falling Mast Hazard!**

Prevent mast from falling:

- Do not lower mast arms until mast is connected to boom rigging. Mast will fall over backwards if raised to vertical when arms are down.

8. Proceed to use mast as a boom with boom hoist control for remainder of assembly procedure.

**NOTE:** The mast will stop lowering and MAST TOO FAR FORWARD fault will come on if the mast is lowered past 172° (View G).



**DANGER**  
**Falling Load Hazard!**

Prevent structural failure of components:

- Do not exceed lifting capacities given in Liftcrane Mast Capacities Chart at end of this section

**Falling Mast Hazard!**

Prevent mast from falling:

- Do not use limit bypass to lower mast below 172°. Mast will fall suddenly

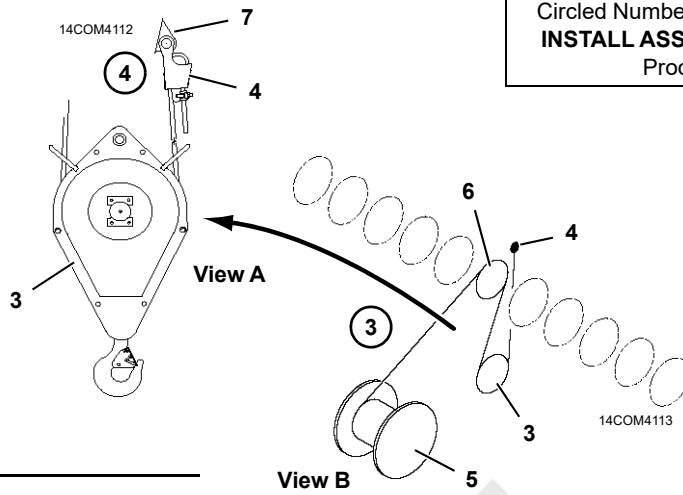
**Operating Note**

360° swing is permitted when crane is on jacks with gantry up and mast lowered to 172°.

14001060

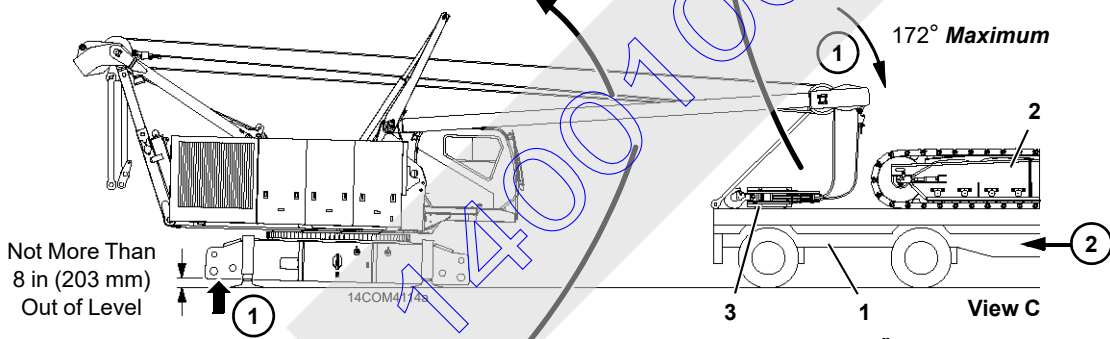


Circled Numbers Correspond to  
**INSTALL ASSEMBLY BLOCK**  
Procedure



**CAUTION**  
**Wire Rope Damage!**  
To prevent damage to wire rope and mast:

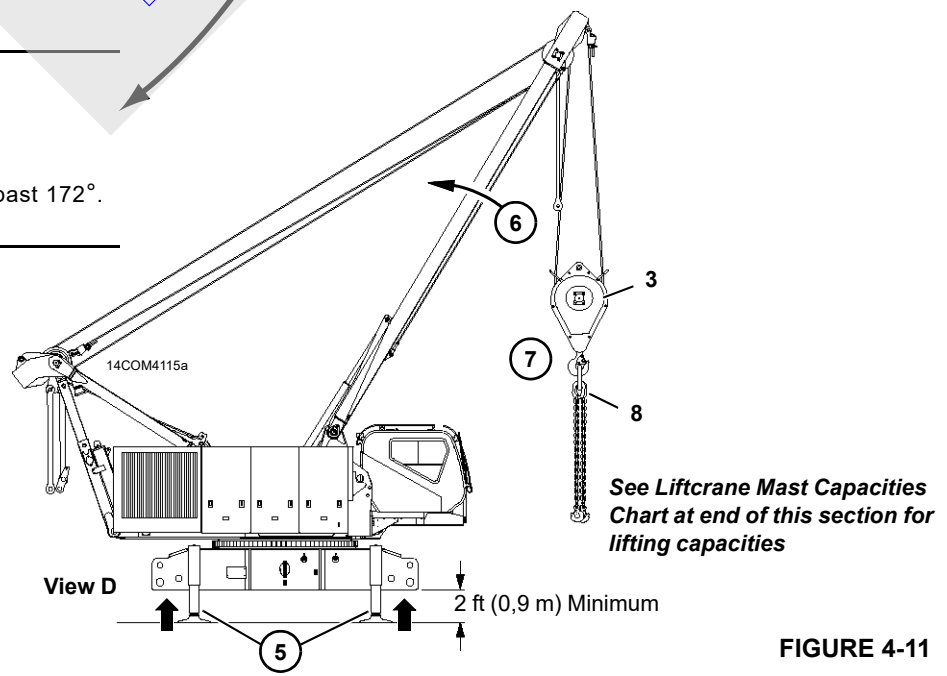
- Do not operate rear load drum until wire rope is clear of lacing in mast.



**! DANGER**  
**Falling Mast Hazard!**

Do not use limit bypass to lower mast past 172°. Mast will fall suddenly.

Item	Description
1	Trailer
2	Crawler
3	Assembly Block
4	Socket and Wedge
5	Rear Drum
6	Center Mast Sheave
7	Lug on Mast
8	4-Leg Chain Sling



See *Liftcrane Mast Capacities Chart* at end of this section for lifting capacities

FIGURE 4-11

## Install Assembly Block

See [Figure 4-11](#) for the following procedure.

**NOTE:** Manitowoc suggests that assembly block (3) be shipped on the same trailer (1) as a crawler (2). Assembly personnel can then stand on the deck of the trailer or the crawler when reeving the block.

1. Position crane and trailer (1) as follows to provide access to mast point sheaves:
  - a. Fully retract jacks (keep crane as level as possible while jacking).
  - b. Raise jacks on side of carbody opposite mast *not more than 8 in (203 mm)*. This step will tip mast down.
  - c. Lower mast to 172°.



### **DANGER** Falling Mast Hazard!

Prevent mast from falling:

- Do not use limit bypass to lower mast below 172°. Mast will fall suddenly

2. Position trailer (1) as shown in View A.

3. Reeve wire rope from rear drum (5, View B) through center sheave (6) in mast point and sheave in assembly block (3).
4. Anchor wire rope to socket and wedge (4, View A) (see Wire Rope Installation on [Page 107](#) for instructions) and connect socket and wedge to lug (7) on mast.
5. Extend jacks so crane is level and carbody is at least 2 ft (0,6 m) off ground (View D).
6. Raise mast to lift assembly block (3) off trailer (2) and position mast in operating range (View D).

### **CAUTION**

#### **Wire Rope Damage!**

Prevent damage to wire rope and mast:

- Do not operate rear load drum until wire rope is clear of lacing in mast (View A)(at approximately 145°)
7. Connect 4-leg chain sling (8, View D) to assembly block (3).

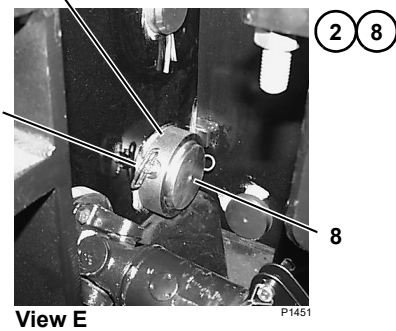
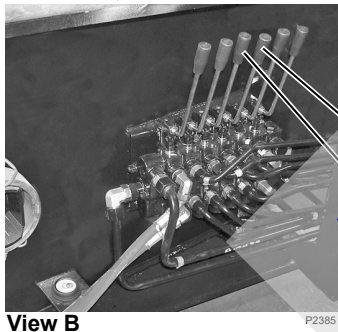
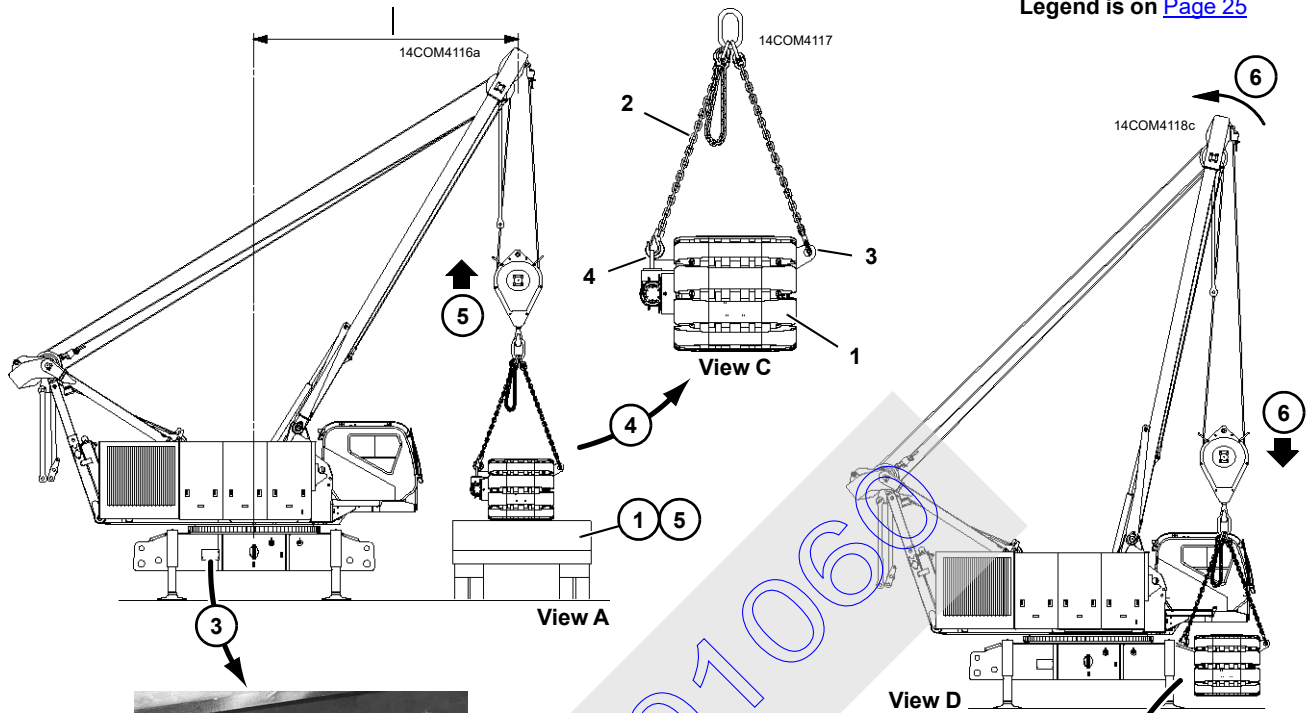
#### **Operating Note**

360° swing is permitted when crane is on jacks with gantry up, mast above 145°, and assembly block and chain sling installed.

See *Liftcrane Mast Capacities Chart* at end of this section for lifting capacities

Circled Numbers Correspond to **INSTALL CRAWLERS** Procedure

Legend is on [Page 25](#)



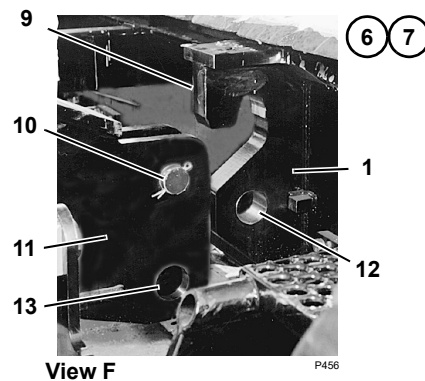
**View H**  
Carbody

\* Pin Holes

**View G**  
Crawler

\* Entire Outside Surface (both sides)

Areas marked \* must be coated with Never-Seez® or equivalent anti-seizing compound prior to assembly



**FIGURE 4-12**

## Install Crawlers



### DANGER

#### Falling Load Hazard!

Prevent structural failure of components while handling either crawler with mast:

- Make sure crane is level. Check level on front of carbody. Adjust jacks as required
- Do not swing 15° either side of center ([Figure 4-13](#))
- Do not exceed lifting capacities given in Liftcrane Mast Capacities Chart at end of this section

### CAUTION

#### Parts Damage!

Avoid hitting carbody jacks with crawlers.

Swing Diagram

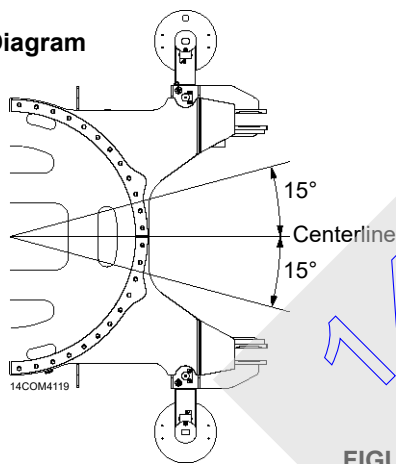


FIGURE 4-13

See [Figure 4-12](#) for the following procedure.

**NOTE:** Each time the crawlers are assembled to the carbody, thoroughly clean and apply Never-Seez<sup>®</sup> or equivalent anti-seizing compound to all machined surfaces on the carbody and the crawlers — surfaces marked Q in Views G and H.

If this step is not performed, excessive friction will occur in the closely machined mating surfaces between the crawlers and the carbody. The result will be loud noises coming from the lowerworks when turning (cutting) the crawlers or swinging the upperworks over the corner of the crawlers.

1. Position trailer with crawler (1) along desired side of crane (View A).

**NOTE:** The crawlers are interchangeable from one side to the other.

Position the crawler drive shafts at the proper ends of the carbody — left side to rear; right side to front.

Carbody remote controls (View B) are at front of carbody.

2. Remove hitch pins (6, View E) and collars (7) from crawler connecting pins (8).
3. Use center handles on carbody remote control (5a and 5b, View B) to retract crawler connecting pins (8, View E).
4. Attach three hooks from chain sling (2, View C) to lifting links (3) on outboard side of crawler and to lifting lug (4) on inboard side of crawler.
5. Slowly hoist crawler clear of trailer and remove trailer.
6. Slowly lower crawler, boom up, and swing to engage hooks (9, View F) on crawler with fixed pins (10) in carbody.
7. STOP lowering and booming when crawler hooks are engaged with fixed pins and connecting holes (12 and 13, View F) are aligned.
8. Engage crawler connecting pins (8, View E) and install collars (7) and hitch pins (6).

#### Legend for [Figure 4-12](#)

Item	Description	Item	Description
1	Crawler	7	Collar
2	Chain Sling (4 leg)	8	Crawler Connecting Pin
3	Lifting Link	9	Hook
4	Lifting Lug	10	Fixed Pin
5a	Left Crawler Pins Control	11	Carbody
5a	Right Crawler Pins Control	12	Crawler Connecting Hole
6	Hitch Pin with Hair Pin Cotter	13	Carbody Connecting Holes

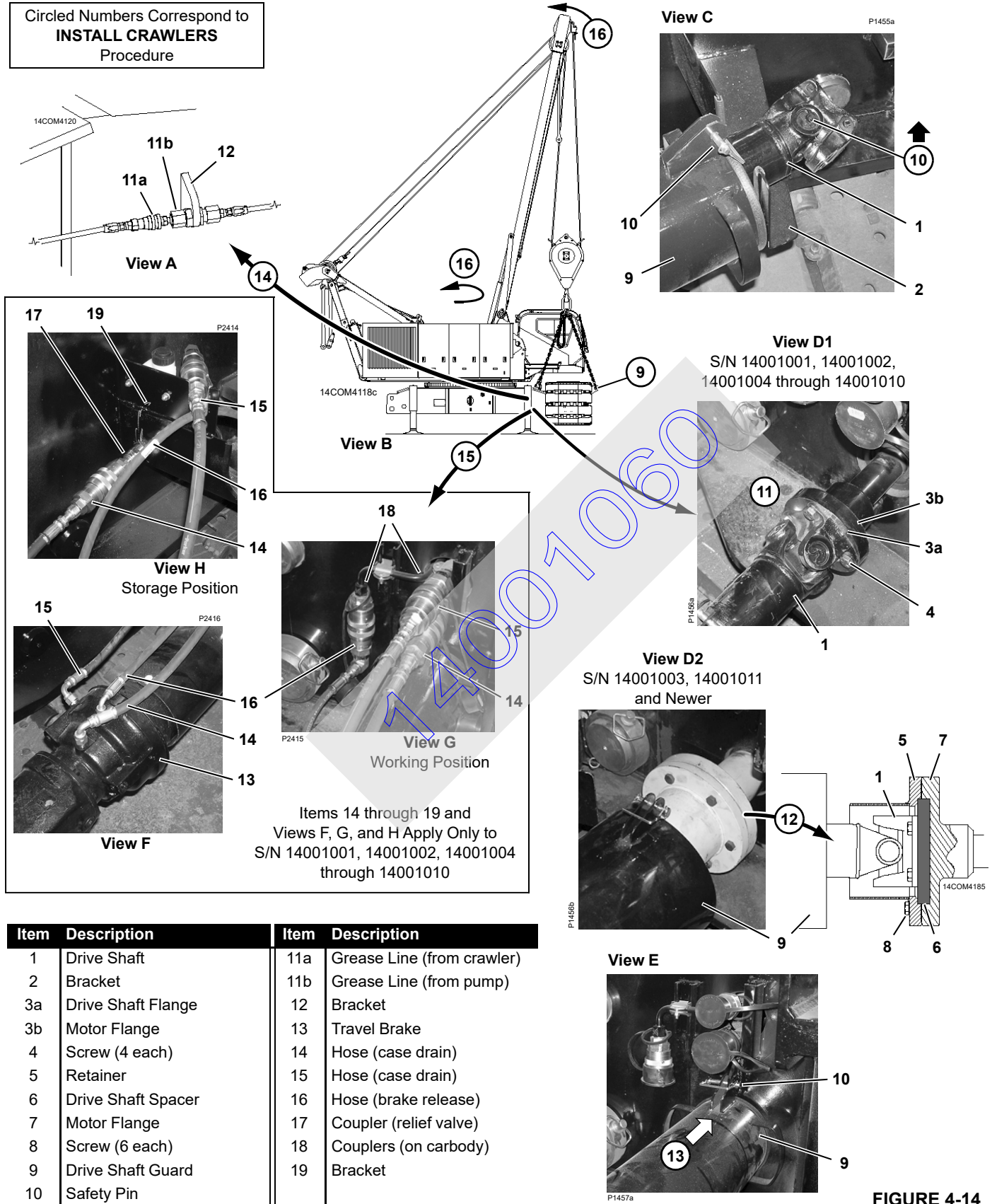


FIGURE 4-14



**DANGER****Rotating Drive Shaft Hazard**

Crawler drive shaft rotates at high speed. Prevent death or serious injury:

- Make sure drive shaft is securely attached at both ends
- Make sure guards are in place and securely attached at both ends during operation
- Do not attempt to service drive shaft until crane has been parked and engine stopped

See [Figure 4-14](#) for the following steps.

9. Unhook chain sling from crawler.
10. Lift crawler drive shaft (1, View C) off bracket (2).
11. For Serial Numbers (S/N) 14001001, 14001002, and 14001004 through 14001010 (see View D1):
  - a. Thoroughly clean ends of mating surfaces.
  - b. Extend drive shaft (1) and align holes in flanges (3a and 3b).
  - c. Insert screws (4) and torque to 74 ft-lb (100 Nm).
12. For S/N 14001003, 14001011 and newer (see View D2):
  - a. Thoroughly clean ends of mating surfaces.
  - b. Extend drive shaft (1) and align drive shaft spacer (6) with flange (7). The spacer (6) is screwed to the drive shaft.
  - c. Align holes in retainer (5) with holes in flange (7).
  - d. Insert screws (8) and torque to 67 ft-lb (91 Nm).
13. Slide guard (9, View E) over drive shaft and pin guard to carbody.
14. If equipped with automatic crawler lube system, connect grease line (11a, View A) to (11b) at bracket (12) on carbody.
15. For S/N 14001001, 14001002, and 14001004 through 14001010, connect travel brake hydraulic hoses in following order:
  - a. Disconnect hydraulic hoses (15 and 16, View H) from each other.
  - b. Disconnect hydraulic hose (14, View H) from coupler (17).
  - c. Connect hydraulic hoses (14, 15, and 16, View G) to couplers (18). Hoses can be connected one way only.

**DANGER****Tipping Hazard!**

Prevent crane from tipping:

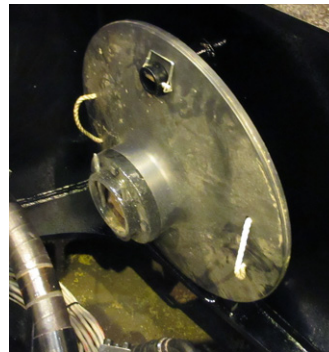
- Do not swing in step [16](#) until mast is raised to 118° or higher.
16. Raise mast to 118° or higher, swing 180°, and repeat steps [1–15](#) for other crawler.

**DANGER****Tipping Hazard!**

Prevent crane from tipping:

- Do not allow assembly block to swing past inside edges of carbody jacks while installing second crawler. Crane will tip.
17. Slowly rotate crawlers (travel forward and back) to center treads on the rollers.
  18. Lower carbody until crawlers are on ground. Then fully retract jacks.
  19. Remove jack pads (8, View E, [Figure 4-8](#)) and store (View D).

Store all but the right front jack pad on the ends of the carbody. Store the right front jack pad on the right inboard side of carbody as shown in [Figure 4-15](#).



Right Front Jack Pad Stored

**FIGURE 4-15**

20. Position each carbody jack as follows (see [Figure 4-8](#)):
  - a. Remove hitch pin (7, View F).
  - b. Swing jack in (View E) for Series 1 and 2 only.  
For Series 3, leave jacks out to allow for installation of the carbody side counterweights.
  - c. Install hitch pin (7).

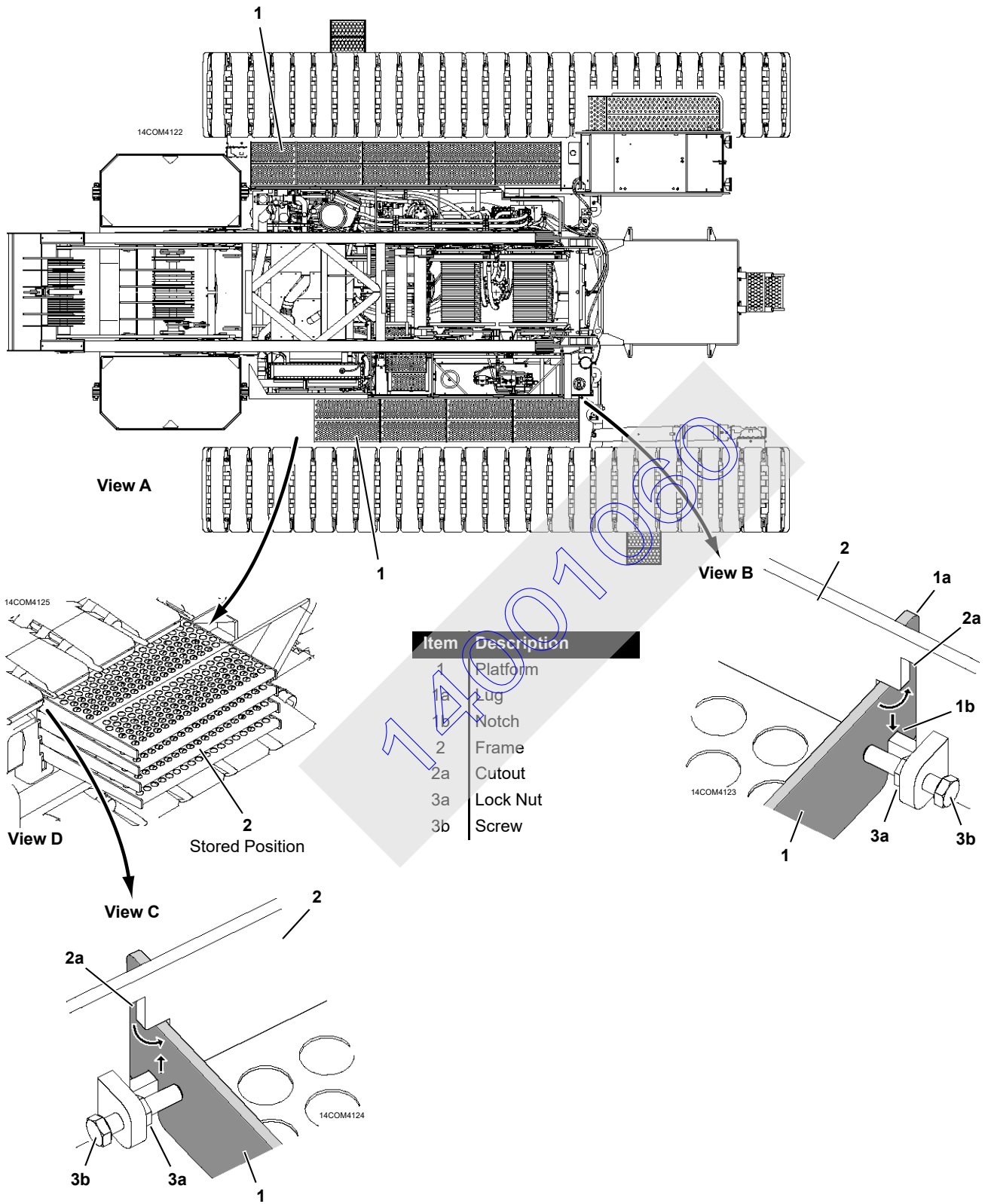


FIGURE 4-16



## Deploy Crawler Steps

Rotate each crawler step ([Figure 4-17](#)) up and out from stored position to working position.

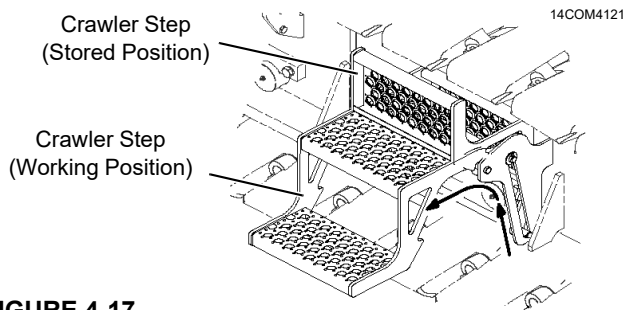


FIGURE 4-17

## Install Platforms

See [Figure 4-16](#) for the following procedure.

There are four removable platforms (1, View A) on the right side of the crane and five on the left side of the crane.

Eight of the platforms are the same length. The left rear platform is shorter than the rest.

The platforms are stored on the crawlers (View D).

1. Remove platforms as follows (View C):
  - a. Loosen lock nut (3a) and screw (3b).

- b. Slide top platform (1) toward screw.
- c. Lift platform up and rotate it out of cutouts (2a) in frame (2).  
Each platform weighs approximately 17 lb (8 kg).
- d. Repeat steps 1a through 1c for remaining platforms.

2. Starting at rear on either side of crane, install platforms as follows (View B):

- a. Lift platform (1) into position.  
Remember — the left rear platform is shorter than the rest.
- b. Hook platform lugs (1a) through cutouts (2a) in frame (2).
- c. Rotate platform (1) down so notches (1b) engage frame (2).
- d. Slide platform to rear as far as it will go.
- e. Install remaining platforms in same manner.
- f. Once all platforms are installed, hand tighten screws (3b) and securely tighten lock nuts (3a) to lock platforms in position.

## Assemble Boom and Jib

Assemble desired boom and jib combination. See Boom and Jib Rigging instructions starting on [Page 69](#).

	Item *						Total Counterweight *	
	1 21,234 lb (9 632 kg)	2 5,910 lb (2 681 kg)	3 17,650 lb each (8 006kg)	4 5,000 lb each (2 268 kg)	5 26,500 lb each (12 020 kg)	6 4,375 lb each (1 985 kg)	Upper	Carbody
<b>Series 1</b>	1	0	3 each side	0	0	0	127,000 (57,606 kg)	0
<b>Series 2</b>	1	1	4 each side	0	1 each end	0	168,000 lb (76,203 kg)	53,000 lb (24,040 kg)
<b>Series 3</b>	1	1	4 each side	1 each side	1 each end	2 each end	178,000 lb (76,203 kg)	70,500 (31 978)

\* Weights are nominal and include weight of miscellaneous parts

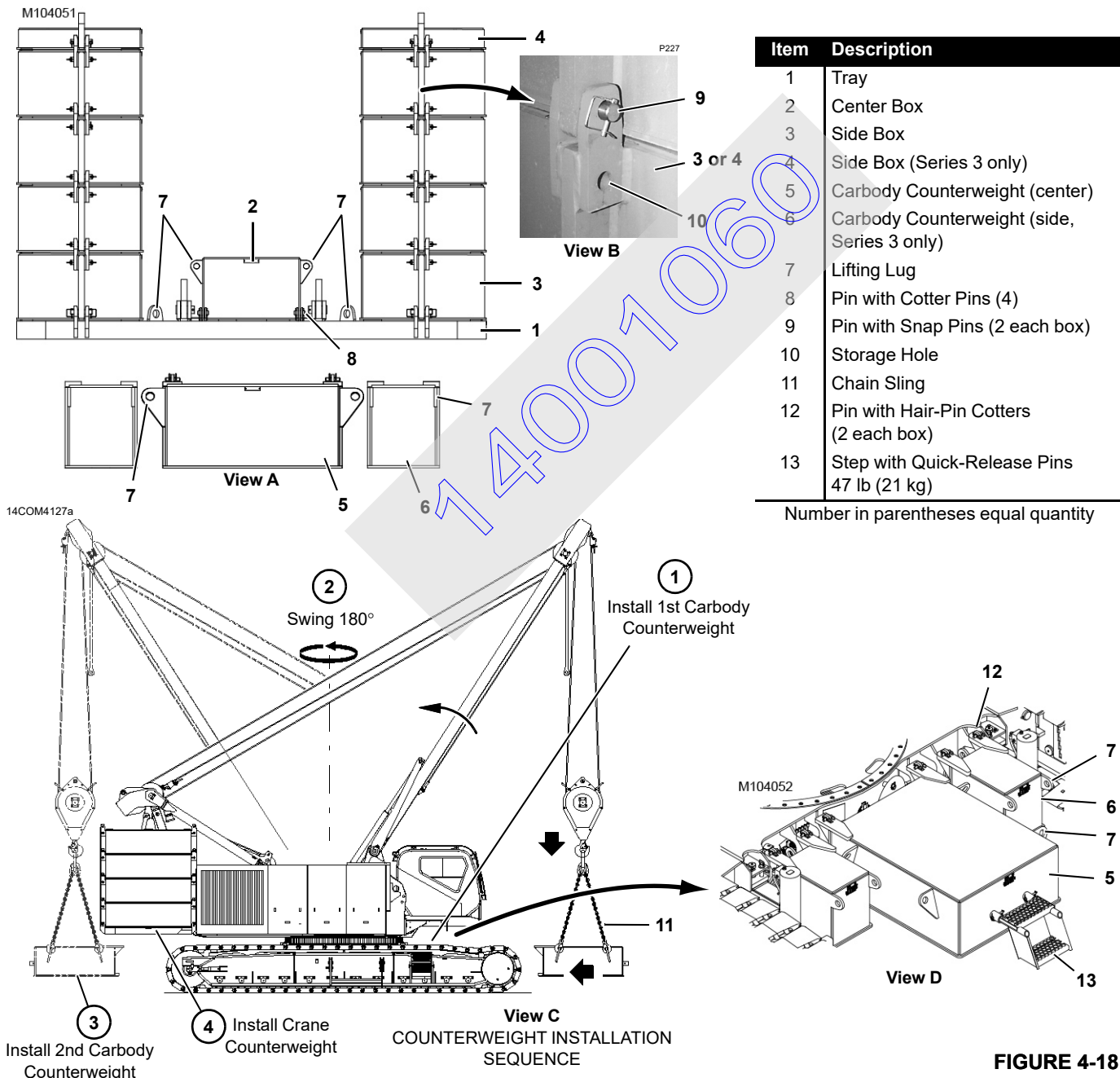


FIGURE 4-18

## Install Counterweight

See [Figure 4-18](#) for the following procedure.



### DANGER

#### Falling Load Hazard

Prevent structural failure of components:

- Do not exceed lifting capacities given in Liftcrane Mast Capacities chart at end of this section

#### Tipping Hazard

Prevent crane from tipping:

- Install carbody counterweight before installing crane counterweight



### WARNING

#### Falling Load Hazard

Prevent lifting lugs from breaking and counterweights from falling:

- Do not lift more than two side boxes at a time
- Do not lift tray with side boxes installed
- Do not lift tray with center box installed

The 14000 can be equipped with Series 1, Series 2, or Series 3 counterweight. The table in [Figure 4-18](#) specifies the counterweight configuration for each series.

The 14000 must be in the following configuration to assemble and install its own counterweight:

- Crane and counterweight on a firm uniformly supporting surface that is level to within 1% grade — 1 ft (0.3 m) in 100 ft (30.5 m)  
Installation will be easier if rear of crane is slightly higher than front of crane — travel rear of crawlers onto blocking approximately 1 in (25 mm) high
- Liftcrane Mast Capacities Chart selected in configuration screen of RCL display
- Mast arms fully raised
- Assembly block and 4-leg chain sling installed
- Mast operated between fully extended mast arms and 145° — 26 ft (7.9 m radius)
- Loads limited to those given in Liftcrane Mast Capacities chart at end of this section
- Rotating bed in-line with crawlers while installing crane counterweight (360° swing is permitted while lifting counterweight and installing carbody counterweights)

## Assemble Crane Counterweight

The 14000 mast can be used to assemble the crane counterweights:

1. Lift tray (1, View A) onto ground. Lift at four lifting lugs (7) with chain sling (11).
2. Lift center box (2, View A) into position and pin to tray (1). Lift at four lifting lugs (7) with chain sling (11).
3. Lift one or two side boxes (3) (angled corners facing out) into position and pin to tray (1) as shown in View B. Lift at connecting pins (9) with chain sling (11).
4. Lift additional side boxes (3) — as required for counterweight series — into position and pin to adjacent side box (View B).
5. For Series 3, repeat step 3 for side boxes (4).

## Install Carbody Counterweight

If equipped with Series 2 or Series 3 counterweight, install carbody counterweights (5 and 6), as follows, before installing crane counterweight.

**NOTE:** Series 2 requires one carbody counterweight (5) at both ends of carbody.

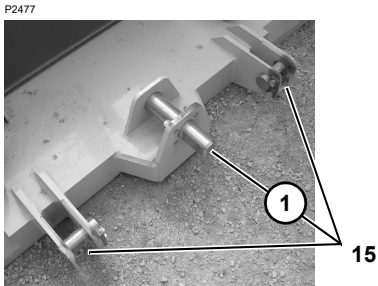
Series 3 requires three carbody counterweights (5 and 6) at both ends of carbody.

If equipped with Series 3, install both carbody side counterweights (6) first.

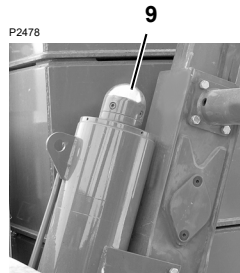
1. For Series 1, go to [Page 4-33](#).
  2. For Series 2 and 3, proceed as follows:
    - a. Hook onto carbody counterweight (6 or 5) with chain sling (11) and lift counterweight into position at desired end of carbody (View C) — lift at three or four lifting lugs (7, View D).
    - b. Boom, swing, and hoist as required to engage cutouts in carbody counterweight (6 or 5) with lugs on carbody (View D).
    - c. Lower carbody counterweight and disconnect chain sling (11).
    - d. Install pins (12, View D) to secure carbody counterweight.
    - e. Pin step (13, View D) to carbody counterweight (5).
- NOTE:** Do not install step at rear of crane until after crane counterweight is installed.
- f. Repeat steps for each carbody counterweight on desired end of carbody.

Circled Numbers Correspond to  
**INSTALL COUNTERWEIGHT**  
Procedure

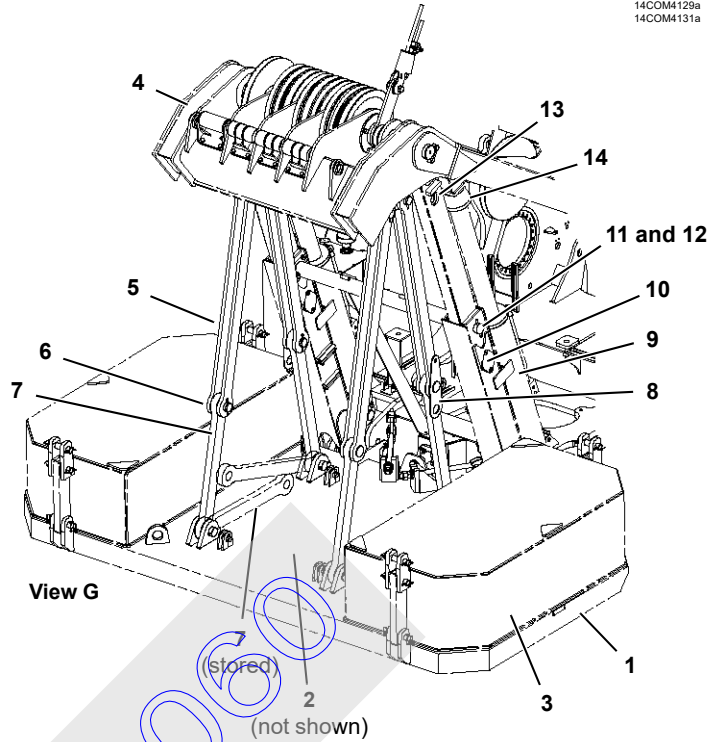
14COM4129a  
14COM4131a



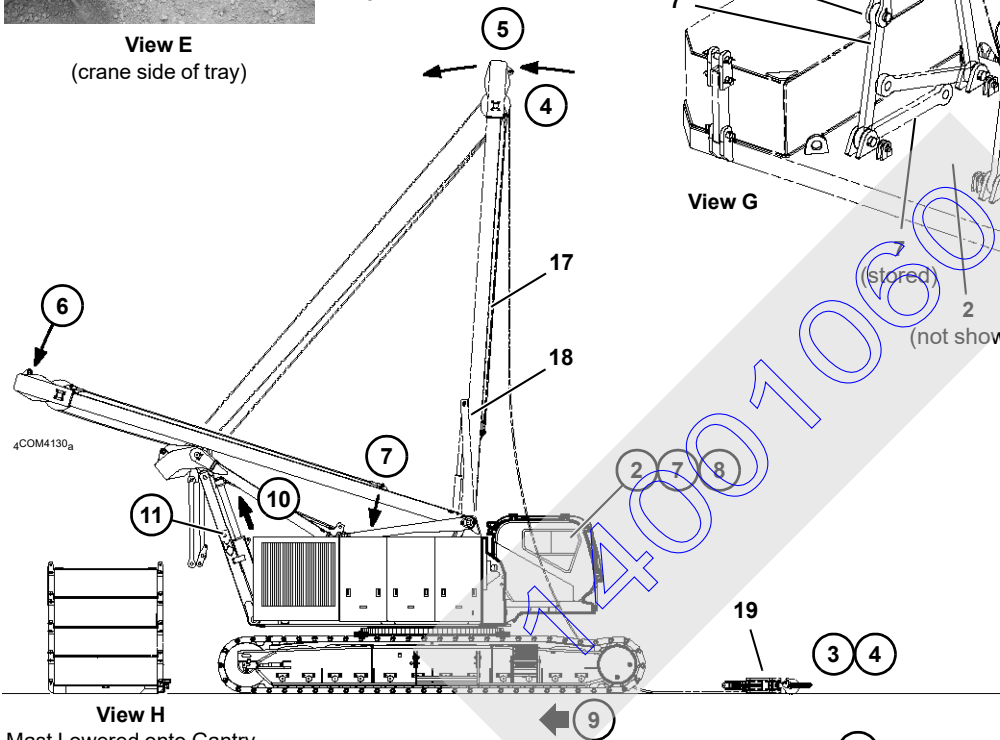
**View E**  
(crane side of tray)



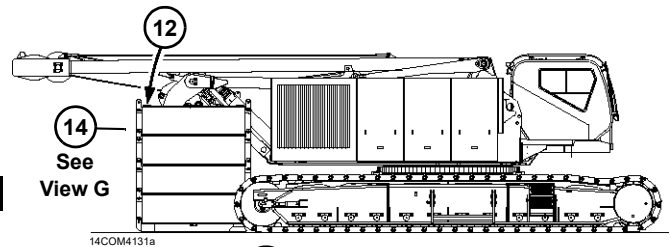
**View F**



**View G**



**View H**  
Mast Lowered onto Gantry



**View J**  
Counterweight On Ground

Item	Description	Item	Description
1	Tray	11	Backhitch Pin (2)
2	Center Box	12	Lower Holes
3	Side Box	13	Upper Holes
4	Gantry	14	Pocket (2)
5	Upper Handling Strap (8)	15	Alignment Pin (3)
6	Pin with Cotter Pin (4)	16	See Next Page
7	Lower Handling Strap (4)	17	Mast
8	Storage Link (2)	18	Mast Arm (2)
9	Gantry Cylinder (2)	19	Assembly Block
10	Backhitch (2)		

Numbers in parentheses equal quantity

**FIGURE 4-18 continued**

**NOTE:** Series 2 crane counterweight is shown for the remainder of this section.

### Install Crane Counterweight

1. Thoroughly clean and lubricate the round rod end of both gantry cylinders (9, View F, [Page 32](#))

Thoroughly clean and lubricate the following items with Never-Seez<sup>®</sup> or equivalent anti-seizing compound:

- Flats of alignment pins (15, View E, [Page 32](#))
- Alignment slots (16, View H, [Page 34](#))



## DANGER

### Moving Part/Crush Hazard!

Avoid being crushed by moving parts:

- Do not stand between counterweight and crane while counterweight is being installed.
- Do not stand on counterweight while it is being raised or lowered.
- Do not climb onto counterweight until gantry is fully raised and backhitch pins are engaged.
- Never go under counterweight until gantry is fully raised and backhitch pins are engaged.

### Falling Mast Hazard!

Prevent mast from falling:

- Do not raise mast to vertical until mast arms (18, View H) are fully raised. Mast will fall over backwards if raised to vertical when arms are down.

**NOTE:** The following controls are used to install the counterweights during the remaining steps. See Section 3 of this manual for identification and operation of these controls.

- MAST SWITCH in operator's cab
- BOOM HOIST CONTROL in operator's cab
- SETUP REMOTE CONTROL to disengage and engage the backhitch pins and to extend and retract the gantry cylinders

- MAIN DISPLAY information screen to monitor the mast operating angle and to identify mast faults.

2. Turn off boom hoist (Drum 4) park switch in operator's cab.
3. Lower assembly block (19, View H) onto ground.
4. Disconnect load line from mast (17) and from assembly block (19) and lay load line on ground in front of crane.
5. BOOM UP slowly with boom hoist control to lower mast over center to rear. Pay out load line as required.
6. Stop lowering mast when it contacts gantry.
7. Fully lower mast arms (18, View H) using switch in operator's cab.
8. Turn on setup remote control in function mode screen of main display.
9. Travel crane so it is in line and centered with crane counterweight (View H).
10. If retracted, extend gantry cylinders (9, View G) with remote control until rods are snug against gantry pockets (14).
11. Remove cotter pins and disengage backhitch pins (11) with remote control. Keep pins disengaged until gantry is lowered (step [12](#)).

**Visually check that both backhitch pins are fully disengaged.**

**NOTE:** The mast will lower and rise automatically with the gantry during the remaining steps.

12. Fully lower gantry (View J) with remote control.
13. Travel crane as required so upper straps (5, View G) are centered over tray.

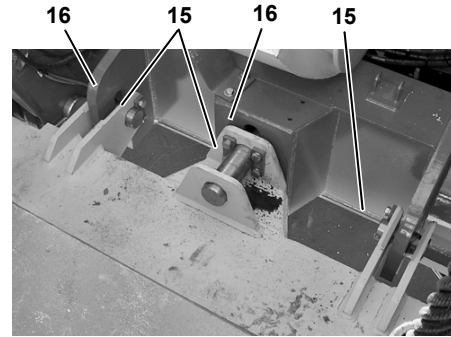
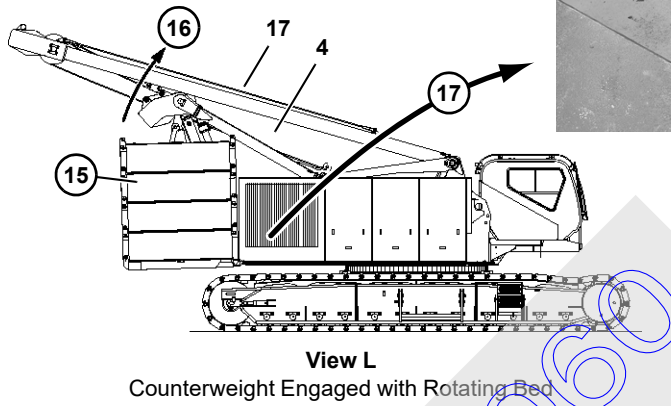
Installation will be easier if rear of crane is slightly higher than front of crane — travel rear of crawlers onto blocking approximately 1 in (25 mm) high.

14. Pin lower handling straps (7, View G) to upper handling straps (5). Keep storage links (8) pinned to inboard straps.



Circled Numbers Correspond to  
**INSTALL COUNTERWEIGHT**  
Procedure

Legend is on [Page 35](#)

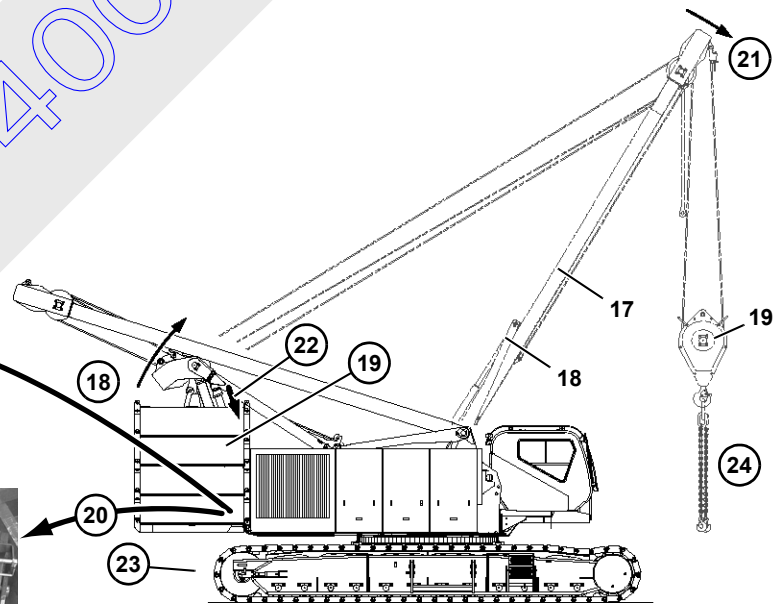


**CAUTION**  
These lugs are for gantry cylinder installation only.  
Do not pin gantry cylinders to these lugs for normal operation of crane.

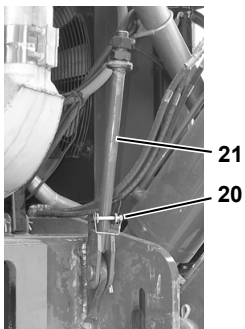


P2469

**View Q**



P2479



P2480

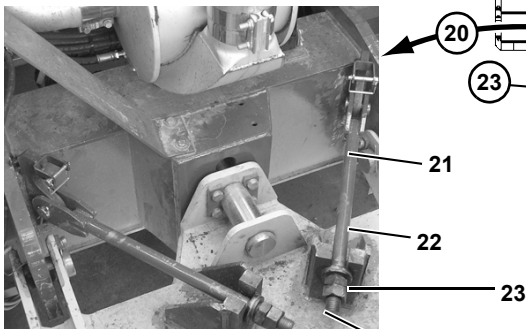


Figure 4-18 continued

- 15. Disengage backhitch pins (11, View R) with remote control. Keep pins disengaged until gantry is fully raised (step 18).
- 16. Raise gantry and counterweight (View L) with remote control. Counterweight may swing in slightly.
- 17. Continue to raise gantry with remote control until alignment pins (15, View K) engage slots (16) in rear of rotating bed.
- 18. Continue to raise gantry (View M) until backhitch lower holes (12, View R) are aligned.
- 19. Engage backhitch pins (11) with remote control.

**Visually check that both backhitch pins are fully engaged.**

Install cotter pins in backhitch pins.

- 20. Connect stabilizer rods:
  - a. Remove snap pins (20, View P) and lower stabilizer rods (21) to working position (View N).
  - b. Reinstall snap pins (20) in storage lugs.

- c. Engage stabilizer rods (21, View N) with brackets (22) and securely tighten flange nuts (23).
- d. Tighten lock nuts (24) against flange nuts (23).

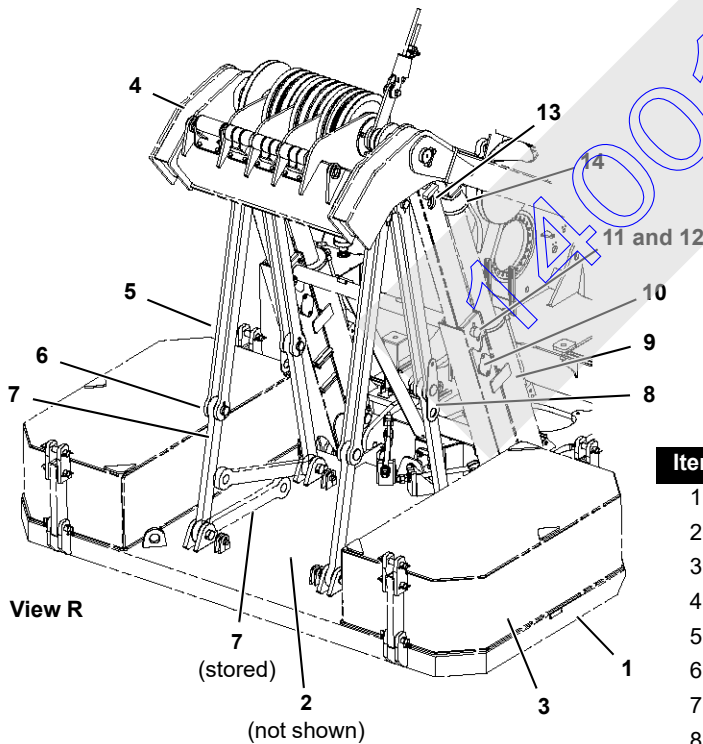
- 21. BOOM DOWN to position mast in operating range (View M).

The mast arms will rise automatically until they contact the mast. Then, the arms will continue to rise to raise the mast.

The mast arms will stop automatically when cylinders are fully extended (at approximately 120°).

**NOTE:** Engine speed will automatically decrease if the throttle is set at less than 1,300 RPM.

- 22. Fully retract gantry cylinders with remote control.
- 23. Pin step to carbody counterweight at rear of crane (see View D, Figure 4-18).
- 24. Reinstall assembly block and complete assembly of crane.

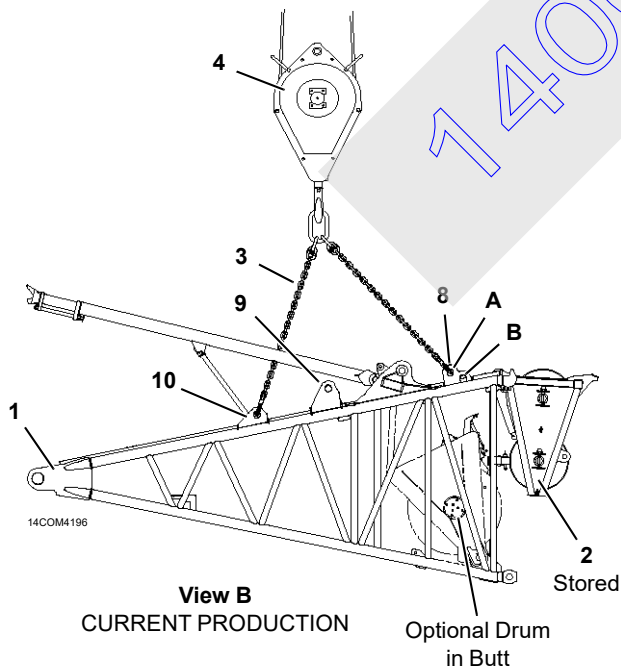
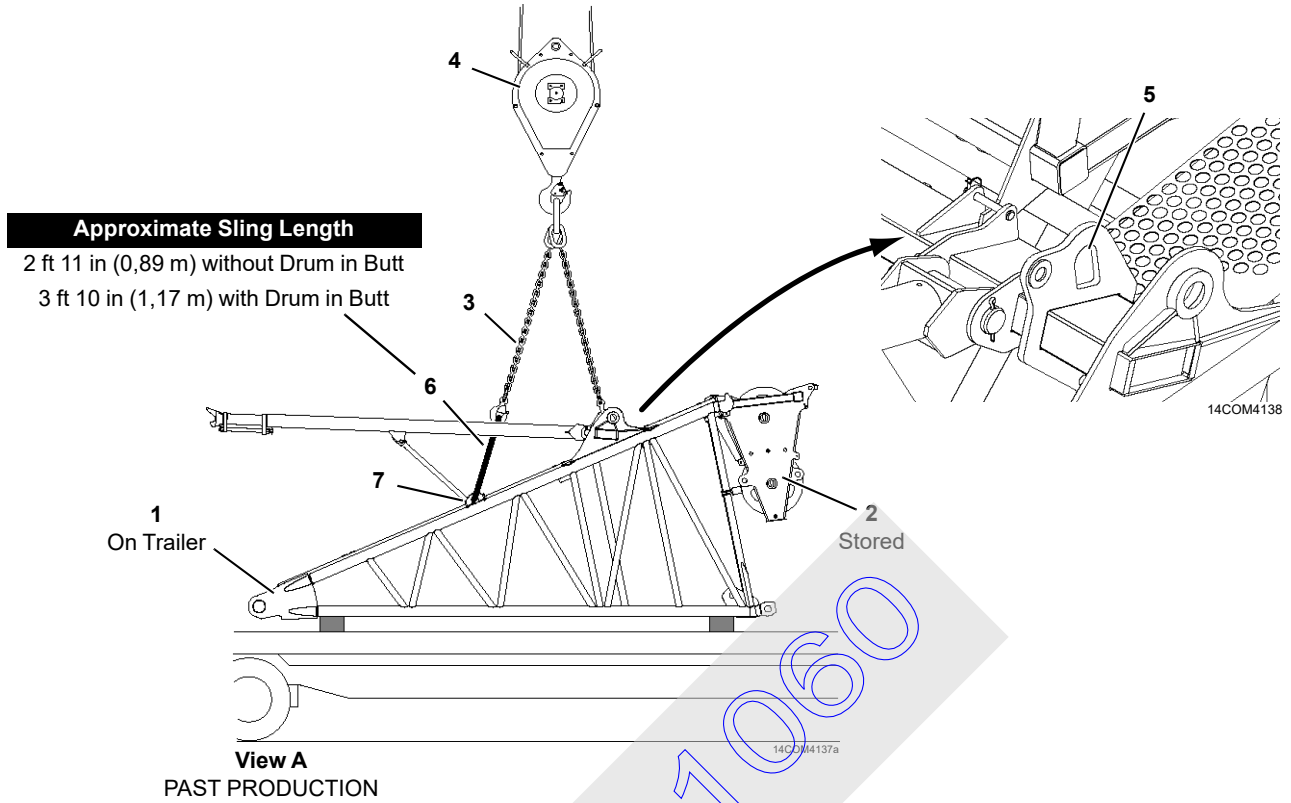


Item	Description	Item	Description
1	Tray	13	Upper Holes
2	Center Box	14	Pocket (2)
3	Side Box	15	Alignment Pin (3)
4	Gantry	16	Slot in Rotating Bed
5	Upper Handling Strap (8)	17	Mast
6	Pin with Cotter Pin (4)	18	Mast Arm (2)
7	Lower Handling Strap (4)	19	Assembly Block
8	Storage Link (2)	20	Snap Pin (2)
9	Gantry Cylinder (2)	21	Stabilizer Rod (2)
10	Backhitch (2)	22	Bracket (2)
11	Backhitch Pin (2)	23	Flange Nut (2)
12	Lower Holes	24	Lock Nut (2)

Numbers in parentheses equal quantity

Figure 4-18 continued





Item	Description
1	Boom Butt
2	Wire Rope Guide
3	Chain Sling (4-leg) <sup>1</sup>
4	Assembly Block
5	Lifting Lug (front) (2)
6	Owner-Furnished Slings (2)
7	Lifting Lug (rear) (2)
8	Lifting Lug (front) (2)
9	Lifting Lug (middle) (2)
10	Lifting Lug (rear) (2)

Numbers in parentheses equal quantity

<sup>1</sup> Same Chain Sling Used for Crawler Handling

FIGURE 4-19

## Install Boom Butt

### Lifting Boom Butt

See [Figure 4-19](#) for the following procedure.

Boom butt (1) is equipped with lifting lugs as shown in Views A and B.

1. To handle PAST PRODUCTION boom butt (1), proceed as follows:

See View A for the following procedure.

- a. Attach chain sling (3) to assembly block (4).
- b. Attach two legs of chain sling to front lifting lugs (5).
- c. Attach other two legs of chain sling and owner-furnished slings (6) to rear lifting lugs (7).

**NOTE:** When the boom butt is lifted with the owner-furnished sling lengths given in View A, the bottom

chords of the butt will be approximately parallel to the ground.

2. To handle CURRENT PRODUCTION boom butt (1), proceed as follows:

**NOTE:** When the boom butt is lifted with the current production lifting lugs, the centerline of the butt will be approximately parallel to ground.

See View B for the following procedure.

- a. Attach chain sling (3) to assembly block (4).
- b. For boom butt WITHOUT DRUM, attach two legs of chain sling to top holes (A) in front lifting lugs (8).  
Attach other two legs of chain sling to rear lifting lugs (10).
- c. For boom butt WITH DRUM, attach two legs of chain sling to bottom holes (B) in front lifting lugs (8).  
Attach other two legs of chain sling to middle lifting lugs (9).

14001060

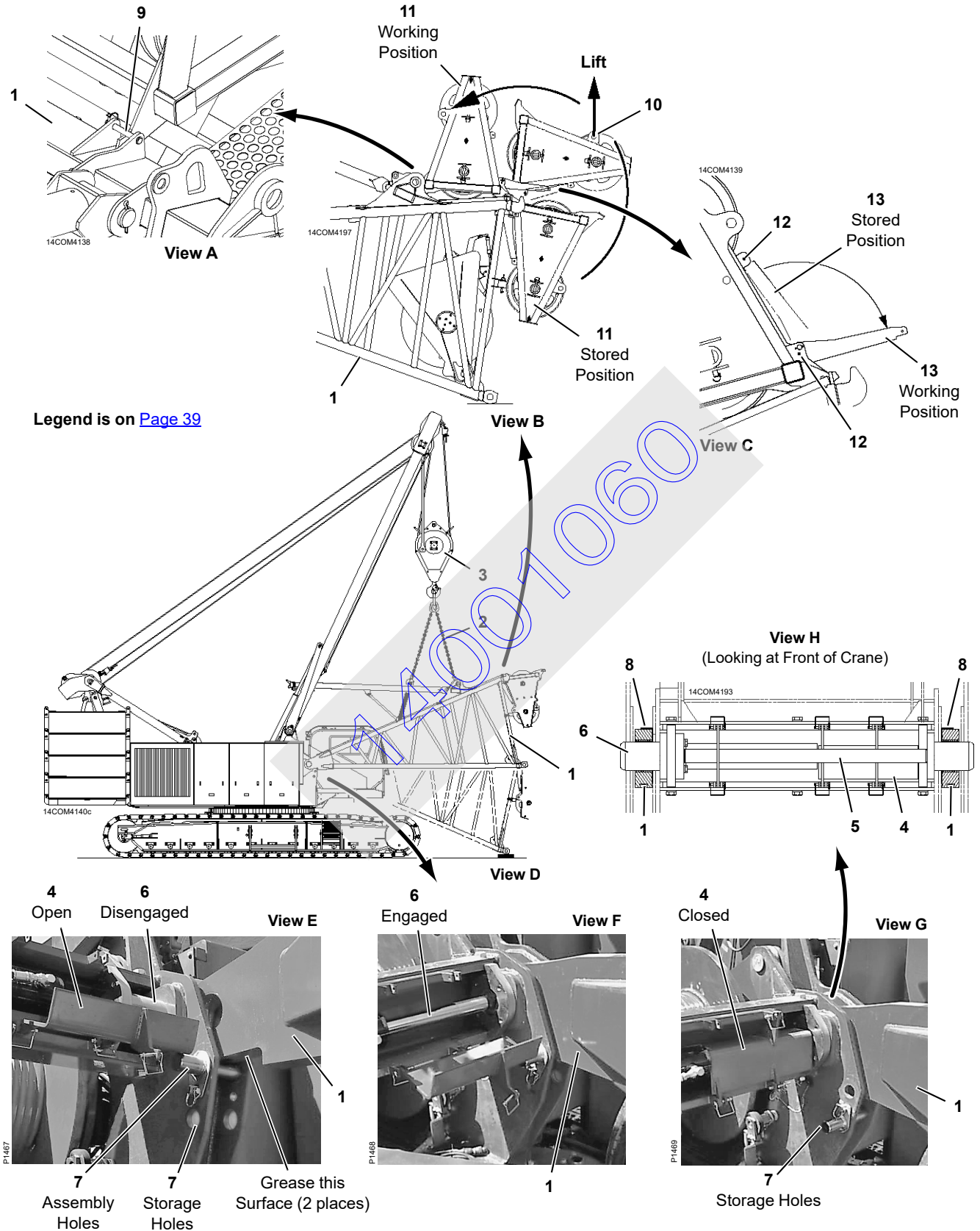


FIGURE 4-20

**Connect Boom Butt to Crane**

See [Figure 4-20](#) for the following procedure.

1. Lift boom butt (1) off trailer and into position at front of crane (View D). Use one of the lifting arrangements shown in [Figure 4-19](#). See Lifting Boom Butt topic.
2. Unpin locking cover (4, View E) and rotate it down.

**NOTE:** Current production cranes have a guard (5, View H) attached to cover (4).

3. Fully disengage boom hinge pins (6, View E) with switch in operator’s cab.
4. Move guide pins (7, View E) from storage holes to assembly holes.
5. Apply a light coat of grease to underside of both boom butt legs (View E).
6. Position butt so underside of boom hinge lugs are on guide pins (7, View E).
7. Slowly mast up — boom butt will slide in — until stops on underside of boom hinge lugs are snug against guide pins (View F).
8. Slowly lower boom butt with load line until holes in butt are aligned with holes in rotating bed.
9. Install a shim (8, View H) — tab toward top of butt and facing outward — on inboard side of both boom hinge lugs. **Shims must be installed to prevent butt from contacting outboard rotating bed lugs.**
10. Fully engage boom hinge pins (6, View F) with switch in operator’s cab.

11. Raise butt slightly and move guide pins (7) from assembly holes to storage holes (View G). **Do not lower boom butt to ground until guide pins are stored.**
12. Rotate locking cover (4) up and pin (View G).

**! WARNING**  
**Falling Boom Hazard!**

Prevent boom butt (or boom) from falling off crane:

- Pin locking cover UP after engaging hinge pins. Cover locks hinge pins in engaged position

13. Lower boom butt onto blocking at ground level and disconnect chain sling from butt.

**Raise Boom Butt Wire Rope Guide**

See [Figure 4-20](#) for the following procedure.

1. Remove pins (9, View A) from lugs on boom butt (1).
2. Attach two legs of chain sling (2) to lifting lugs (10, View B) on wire rope guide (11).
3. Lift wire rope guide to working position and install pins (9, View A).
4. Disconnect chain sling.
5. Remove pins (12, View C) from upper holes, lower platform (13) to working position, and reinstall pins (12) in lower holes.

**Legend for [Figure 4-20](#)**

Item	Description	Item	Description
1	Boom Butt	8	Shim – 0.134 in (3,4 mm) thick (2)
2	4-Leg Chain Sling	9	Pin with Snap Pin (2)
3	Assembly Block	10	Lifting Lug (2)
4	Locking Cover with Snap Pins	11	Wire Rope Guide
5	Guard (round bar)	12	Pin with Hair-Pin Cotter (2)
6	Boom Hinge Pin (2)	13	Platform
7	Guide Pin (2)		

Numbers in parentheses equal quantity

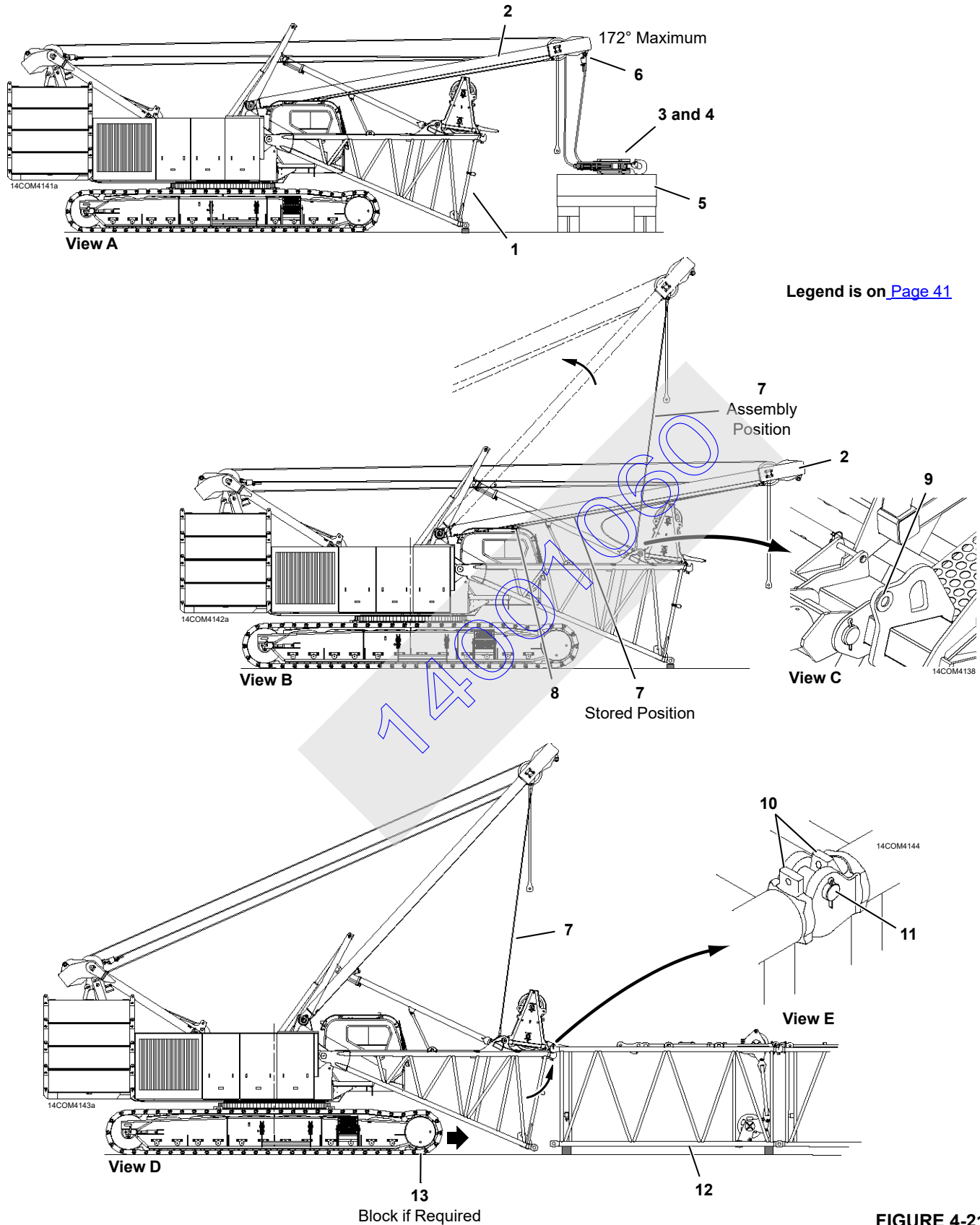


FIGURE 4-21

### Remove Assembly Block

See [Figure 4-21](#) for the following procedure.

1. Lower mast (2, View A) to 172° and lower assembly block (3) and chain sling (4) onto trailer (5) or onto ground.



#### **DANGER** Falling Mast Hazard!

Prevent mast from falling:

- Do not use limit bypass to lower mast below 172°. Mast will fall suddenly.

#### **CAUTION**

Avoid mast and wire rope damage:

- Do not lower mast onto boom butt wire rope guide. Lacings can be damaged
  - Wire rope will contact lacings in mast when mast is lowered. Take care not to damage wire rope or mast when removing wire rope
2. Disconnect wire rope from socket and wedge (6, View A) on mast lug. Store socket and wedge with assembly block.
  3. Remove wire rope from assembly block and mast point and spool wire rope onto rear drum.
  4. Remove trailer (if used) from assembly area.

### Connect Boom Butt to Boom

See [Figure 4-21](#) for the following procedure.

1. Disconnect pendants (7, View B) from storage lugs (8) on mast (2).
2. Pin pendants (7, View B) to lifting lugs (9, View C) on boom butt (1).
3. Raise mast until pendants are taut and supporting boom butt (1).
4. Position crane so boom butt (1, View D) is in line with boom.
5. Travel forward slowly, swing, and boom up and down as needed to align hooked connectors (10, View E) in boom butt with fixed pins (11) in insert (12).



#### **WARNING** Tipping Hazard!

Prevent crane from tipping:

- Block crawlers — if required per capacity chart — before attempting to raise boom
6. Check appropriate capacity chart to see if crawlers must be blocked to raise boom. If so, proceed as follows:
    - a. Mark ground at center of front crawler roller (13, View D) and tumbler located under boom butt.  
See Crawler Blocking Diagram in Capacity Chart Manual for blocking requirements.
    - b. Slowly travel in reverse several feet.
    - c. Place required blocking on ground at points marked in step [6a](#).
    - d. Repeat step [5](#) while traveling onto blocking.

Legend for [Figure 4-21](#)

Item	Description	Item	Description
1	Boom Butt	14	Pin with Safety Pin
2	Mast	15	Mast Strap
3	Assembly Block	16	Boom Straps (on first insert)
4	Chain Sling	17	Pin with Collar, Retaining Pin and Cotter Pins
5	Trailer	18	Strap Storage Link
6	Dead-End Socket and Wedge	19	Pin with Cotter Pin
7	Pendant	20	Electric Cable from Cable Reel
8	Storage Lug	21	Hydraulic Couplers
9	Lifting Lug	22	Hydraulic Hoses
10	Hooked Connector	W34API	Electric Cable from Drum 3
11	Fixed Pins	W33API	Electric Cable from Drum 3 Bail Limit
12	Insert	WBC	Electric Cable from Engine Node
13	Front Crawler Roller		



Legend is on [Page 41](#)

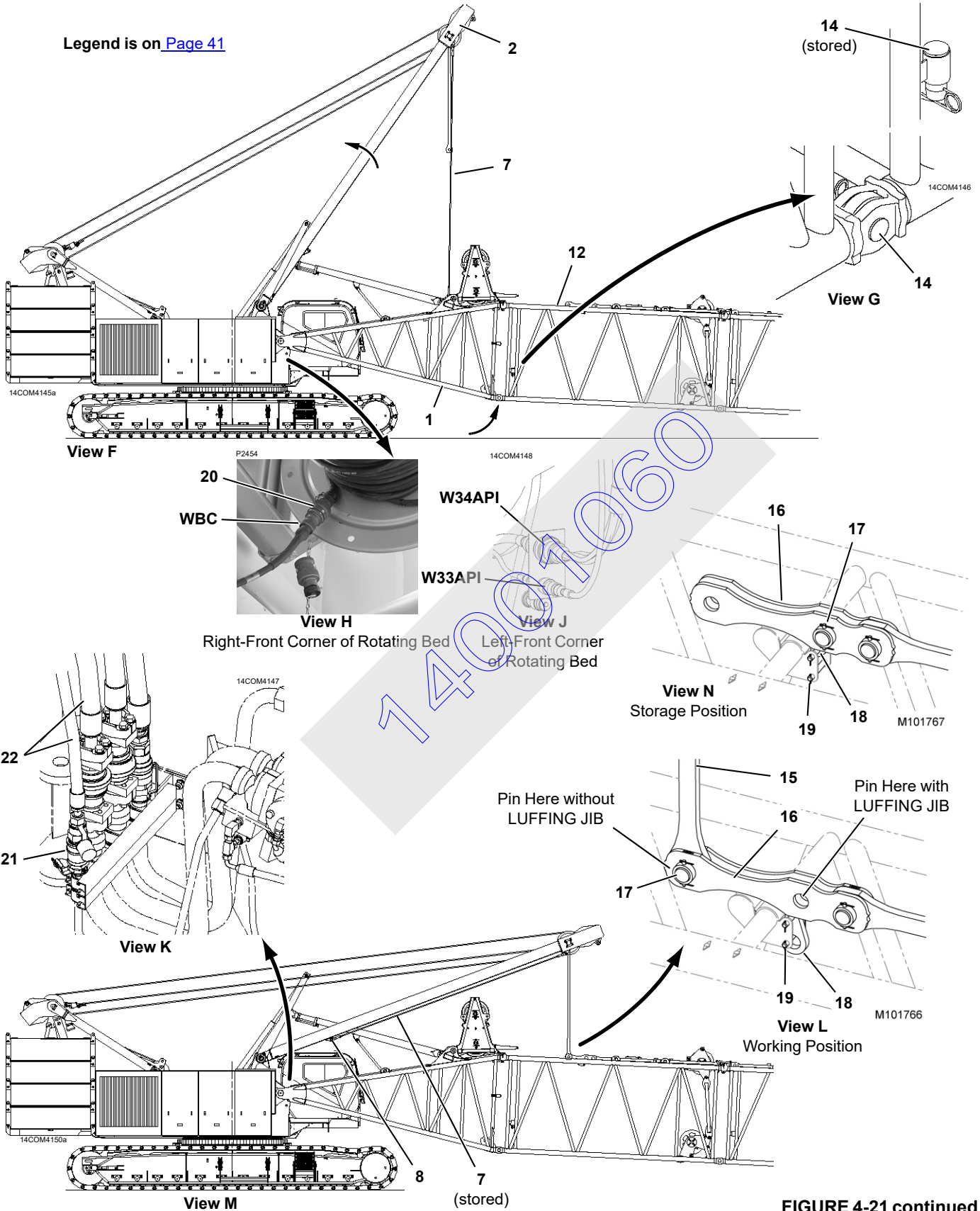


FIGURE 4-21 continued



**CAUTION****Boom Butt Damage!**

Avoid overload damage to boom butt:

- Do not allow bottom connectors in butt to bottom out against bottom connectors in insert while performing step 7.
- Do not continue to boom up after bottom connector pins are installed.

**WARNING****Moving Part Hazard!**

Prevent serious crushing injury:

- Do not stand inside boom while installing connector pins — **STAND OUTSIDE BOOM**
7. Slowly raise mast only enough to align bottom connector holes in butt with bottom connector holes in insert (12, View F).
  8. Remove pins (14, View G) from storage and pin boom butt to insert.
  9. Unpin pendants (7, View F) from lifting lugs on boom butt and pin pendants to storage lugs (8, View M) on mast (2).
  10. Connect mast straps to boom straps:
    - a. Remove pins (17, View N) from boom straps (16).
    - b. Remove pin (19, View N) from both storage brackets.
    - c. Rotate the strap storage links (18, View N) to the working position (View L).
    - d. Install pin (19, View L) to secure strap storage links (18) in working position.
    - e. Position mast so holes in mast straps (15, View L) are aligned with proper holes in boom straps (16).
    - f. Install pins (17, View L).

**NOTE:** When performing following steps, thoroughly clean ends of hydraulic hoses, couplers, cable plugs, and receptacles before connecting them.

11. Disconnect electric cable WBC (View B, [Figure 4-8](#)) from terminating plug on right-front corner of rotating bed. **Attach dust cap to terminating plug.**
12. Connect electric cable WBC (View H) to electric cable (20) from cable reel in boom butt.
13. If equipped with Drum 3 in boom butt, proceed as follows:
  - a. Remove dust caps from couplers (21, View K) at left-front corner of rotating bed.
  - b. Remove dust caps from couplers on four hydraulic hoses (22, View K) in boom butt.
  - c. Connect hydraulic hoses (22) to couplers (21).
  - d. Connect electric cable(s) W34API and W33API (View J) from Drum 3 to receptacles on front of rotating bed.
14. Install wind speed indicator assembly if removed for shipping. Use star washers to attach mounting bracket to boom top to provide a good ground (see Wind Speed Assembly drawing at the end of this section).  
Connect electrical cable WWCB at base of wind speed mounting bracket.

**DANGER****Falling Mast/Boom Hazard!**

Prevent mast and boom from falling:

- Fully lower mast arms before raising boom. **Mast can buckle and collapse if it contacts mast arms with a fully rigged boom**
15. Lower mast arms using switch in operator's cab.
  16. Select proper capacity chart on configuration screen of RCL display.
  17. Boom can now be raised. **Perform Pre-Raising Checks on [Page 4-44](#).**

## PRE-RAISING CHECKS

Make the following checks and correct any defects before raising attachment:

- Crane on firm, level surface with crawlers blocked if required per capacity chart.
- Boom hinge pins fully engaged and locking cover pinned in up position.
- Crawler connecting pins engaged and locking pins installed.
- Carbody jack pads stored.
- Carbody jacks fully retracted and pinned in stored position.
- Boom and jib inserts installed in proper sequence per assembly drawings.
- Pile driver adapter attached to boom top, if equipped.
- Links properly connected between all straps.
- All insert and pendant connector pins installed. Cotter pins installed and spread.
- Gantry fully raised.
- Mast arms fully lowered.
- Boom hoist wire rope spooled tightly onto the drum and engaged with proper sheaves. Wire rope securely anchored to socket and wedge at gantry.
- Load lines spooled tightly onto drums and engaged with proper sheaves. Load lines securely anchored to socket and wedge at boom and jib point or at load block and weight ball.
- All blocking, tools, and other items removed from boom and jib.
- Automatic boom stop properly installed and operational.
- Electric cable from crane control system connected to cable reel on boom butt.
- Electric cables in boom and jib connected to proper receptacles on junction boxes.
- Block-up limit control properly installed and operational.
- RCL properly installed and operational.
- Proper capacity chart selected on configuration screen of RCL display.
- Crane and attachment properly lubricated.
- Wind within allowable limits for operation given in capacity chart.

## CRANE DISASSEMBLY

### Lower Boom and Jib to Ground



#### WARNING

##### Tipping Hazard!

Prevent crane from tipping:

- Block crawlers if required per capacity chart before lowering boom

#### 1. Prepare crane and boom as follows:

- a. Position crane in disassembly area.
- b. If required per capacity chart, travel front crawler roller and tumbler at boom end of crane onto blocking.

See Crawler Blocking Diagram in Capacity Chart Manual for blocking requirements.

#### CAUTION

##### Avoid Damage!

Prevent damage to jib or boom point:

Lower boom as instructed in the following step

#### 2. Lower boom to ground as follows:

- **If equipped with a fixed jib**, disconnect jib stops before jib point contacts ground. See Jib Rigging instructions starting on [Page 96](#) for procedure.
- **If equipped with a luffing jib**, disengage jib stop strut pins before maximum boom to luffing jib angle is reached. See Luffing Jib Operator Manual for procedure.
- **If equipped with an upper boom point**, remove bottom connecting pins (14, View F, [Figure 4-34](#)) before upper point contacts ground.

#### 3. Install blocking at least 8 in (203 mm) high between ground and bottom connectors at end of boom top.

#### CAUTION

##### Avoid Damage!

Prevent damage to dead-end link in lower boom point:

- Guide dead-end link to rear as boom is lowered onto blocking

4. Continue to lower boom onto blocking until boom straps are resting in brackets on boom inserts OR, if equipped with intermediate suspension, proceed as follows:

See [Figure 4-35](#) for the following steps.

- a. Stop lowering boom once it is resting on blocking.
- b. Boom up or down as required so pins (10, View G) are loose.
- c. Remove pins (10).
- d. Boom down until lower strut (1a) is resting on pins (8, View D).

- e. Store pins (10, View D) in each end of bottom strut (1b).
  - f. Boom up or down as required so pins (9, View F) are loose.
  - g. Remove pins (9).
  - h. Boom down until upper strut (1a) is fully lowered to shipping position and install pins (9, View D).
  - i. Continue to boom down until straps (4, View E) and strap links (7) are resting on boom sections.
5. Disconnect load lines from load block and weight ball and spool load lines onto load drums.

14001060

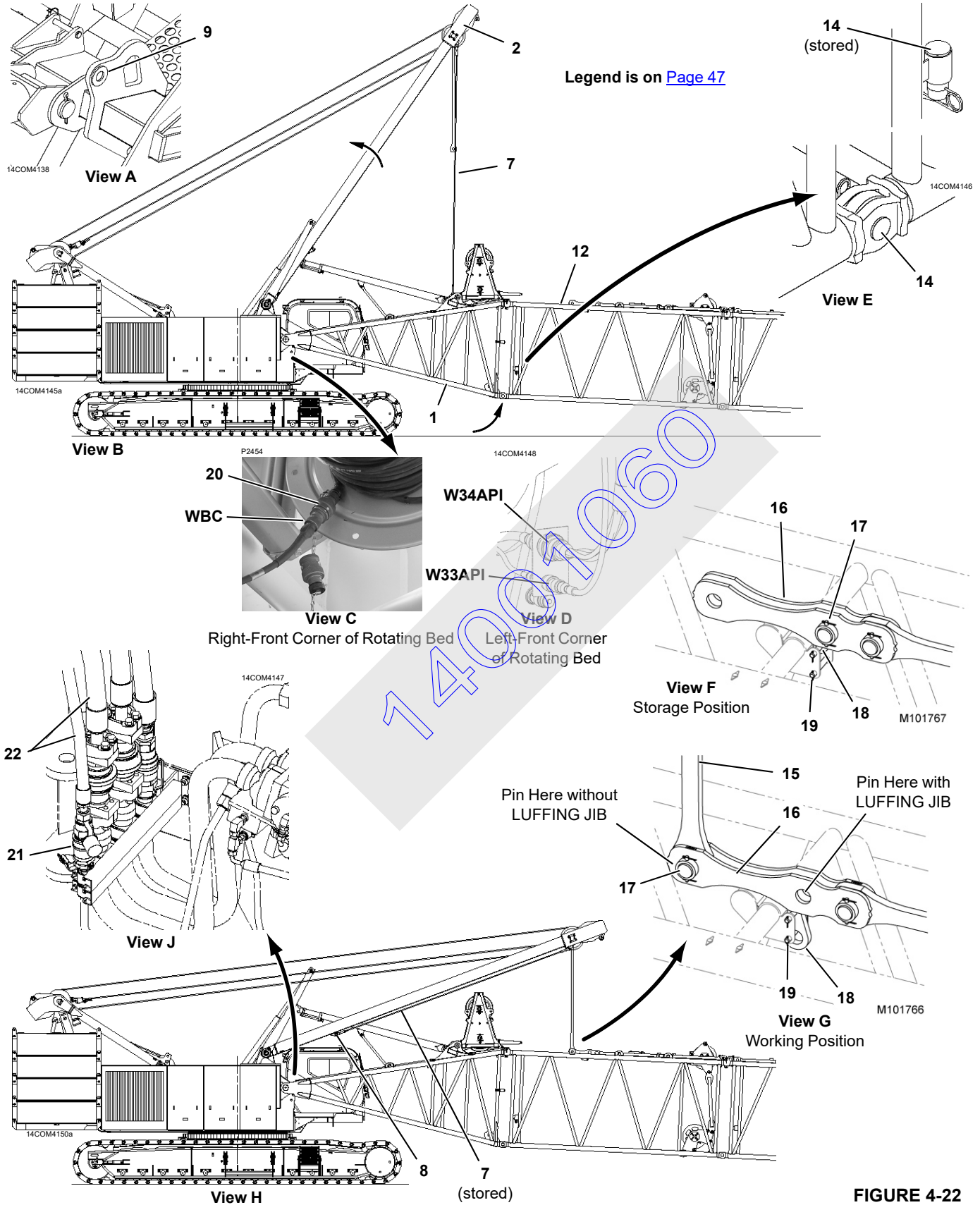


FIGURE 4-22

## Disconnect Boom Butt from Boom

1. Select Liftcrane Mast Capacities Chart in configuration screen of RCL display.

The mast and gantry controls will not operate properly and the mast operating limits will remain off until the proper capacity chart is selected.

Unless otherwise specified, see [Figure 4-22](#) for the following procedure.

2. Disconnect electric cables as follows:
  - a. Disconnect cable WBC (View C) from cable reel (20) on boom butt.  
Connect cable WBC to terminating plug (1, View B, [Figure 4-8](#)) on rotating bed.
  - b. If equipped, disconnect electric cables W33API and W34API (View D) from front of rotating bed. Coil cables on butt for storage.  
Connect terminating plug (1, View C, [Figure 4-8](#)) to cable (2b) on rotating bed.
  - c. Coil excess cable onto cable reel.
  - d. **Install dust caps on ends of all electric cables.**
3. Disconnect hydraulic hoses (22, View J) from boom butt at couplers (21) on front of rotating bed. **Install dust caps on ends of all hoses and couplers.**
4. Fully raise mast arms using switch in operator's cab.



### DANGER

#### Falling Mast/Boom Hazard!

Prevent mast from falling:

- Fully raise mast arms before raising mast. Mast will fall over backwards if raised to vertical when arms are down
5. Disconnect mast straps from boom straps:
    - a. Lower mast so pins (17, View G) are loose.
    - b. Remove pins (17, View G) from boom straps (16).
    - c. Raise mast so mast straps (15, View G) are clear of boom straps (16).
    - d. Remove pins (19, View G) from storage brackets.
    - e. Rotate strap storage links (18, View G) to storage position (View F) and install pins (17) through holes in boom straps (16) and strap storage links (18).
    - f. Install pins (19, View F) in storage brackets.
  6. Unpin pendants (7, View H) from storage lugs (8) on mast (2) and pin pendants to lifting lugs (9, View A) on boom butt (1).
  7. Slowly raise mast (View B) only enough to support boom butt so pins (14, View E) are loose.
  8. Remove pins (14, View E) from holes between inserts.
  9. Store pins (14, View E).

Legend for [Figure 4-22](#)

Item	Description	Item	Description
1	Boom Butt	14	Pin with Safety Pin
2	Mast	15	Mast Strap
3	Assembly Block	16	Boom Straps (on first insert)
4	Chain Sling (not shown)	17	Pin with Collar, Retaining Pin and Cotter Pins
5	Trailer	18	Strap Storage Link
6	Socket and Wedge	19	Pin with Cotter Pin
7	Pendant	20	Electric Cable from Cable Reel
8	Storage Lug	21	Hydraulic Couplers
9	Lifting Lug	22	Hydraulic Hoses
10	Hooked Connector	W34API	Electric Cable from Drum 3
11	Fixed Pin	W33API	Electric Cable from Drum 3 Bail Limit
12	Insert	WBC	Electric Cable from Engine Node
13	Front Crawler Roller		

**CAUTION**

**Wire Rope Damage!**

To prevent damage to wire rope and mast:

- Do not operate rear load drum until wire rope is clear of lacing in mast

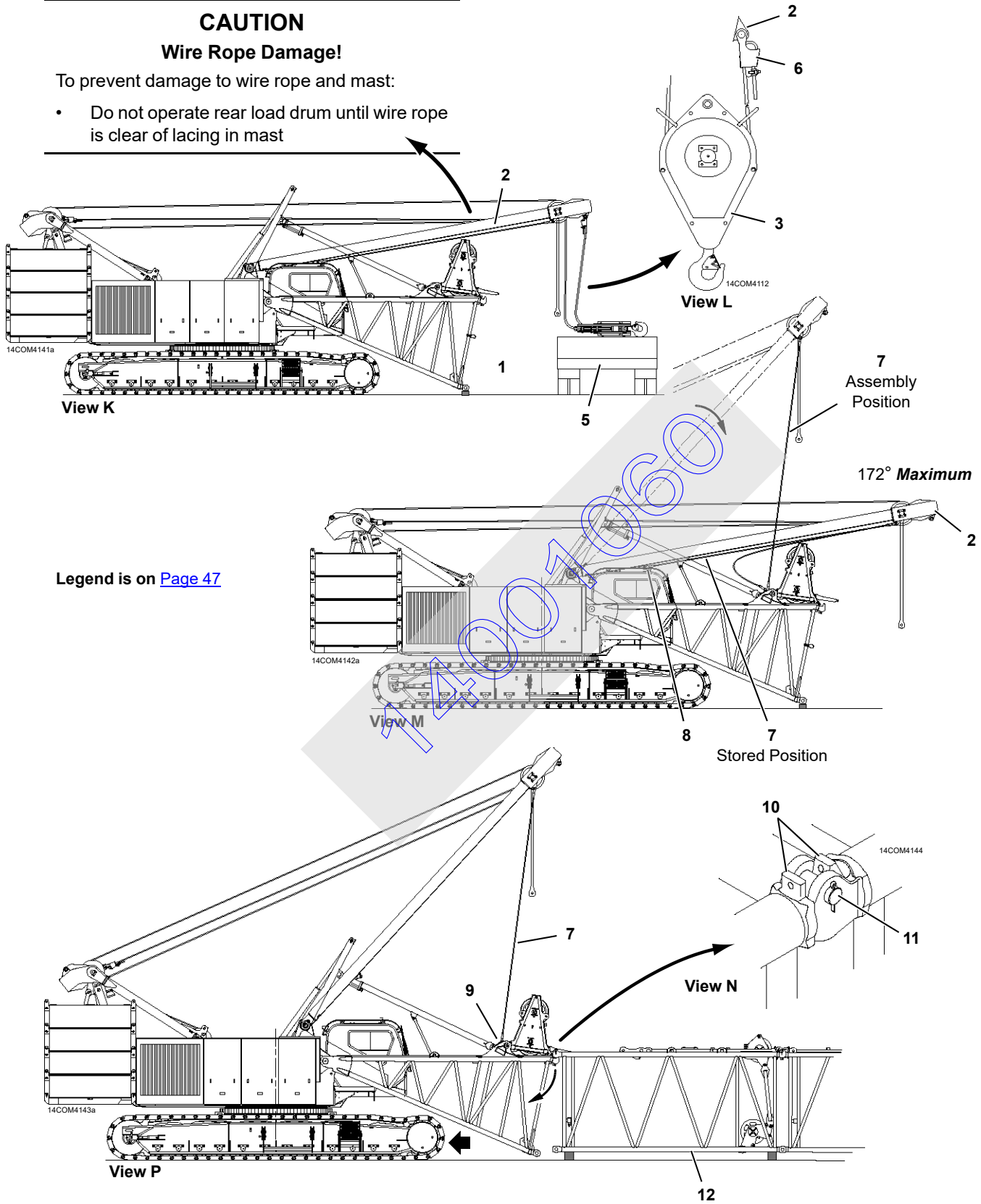


FIGURE 4-22 continued

10. Boom down until hooked connectors (10, View N) in boom butt disengage fixed pins (11) in insert (12).
11. Travel away from boom.
12. Lower boom butt onto blocking (View M).
13. Lower mast to approximately 172°.
15. Pin pendants (7, View M) to storage lugs (8) on mast (2).
16. Position trailer as shown in View K.
17. Reeve wire rope from rear drum through center sheave in mast point and sheave in assembly block (see View B, [Figure 4-11](#)).
18. Anchor wire rope to socket and wedge (6, View L) (see Wire Rope Installation on [Page 107](#) for instructions) and connect socket and wedge to lug on mast.
19. Raise mast to lift assembly block (3) off trailer and position mast in operating range.

**DANGER****Falling Mast Hazard!**

Prevent mast from falling:

- Do not use limit bypass to lower mast below 172°. Mast will fall suddenly

**CAUTION**

Avoid mast and wire rope damage:

- Do not lower mast onto boom butt wire rope guide. Lacings can be damaged

- 
14. Disconnect pendants (7, View M) from lifting lugs on boom butt.

**CAUTION****Wire Rope Damage!**

Prevent damage to wire rope and mast:

- Do not operate rear load drum until wire rope is clear of lacing in mast (View A) (at approximately 145°)

- 
20. Connect 4-leg chain sling to assembly block.

140010660



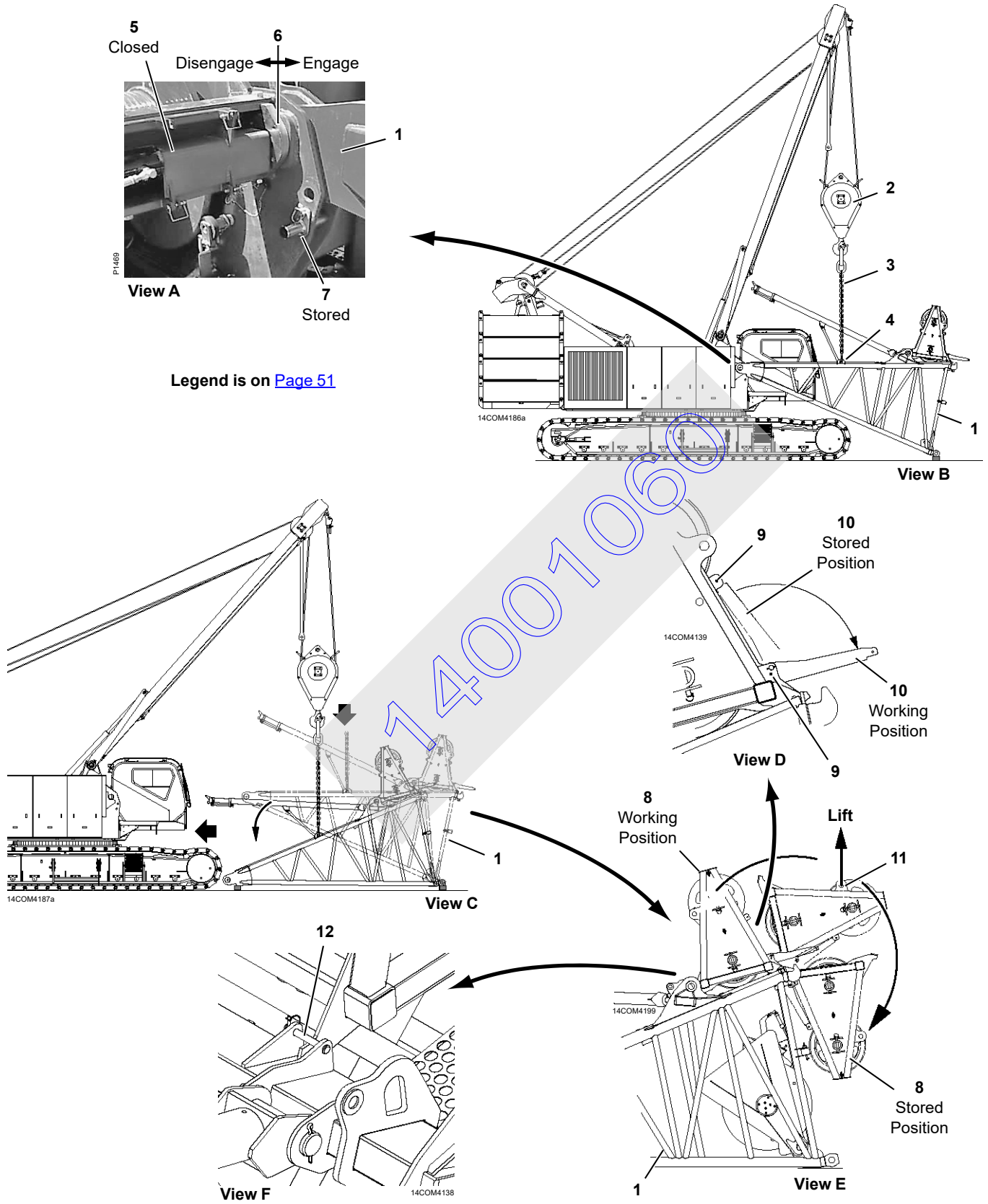
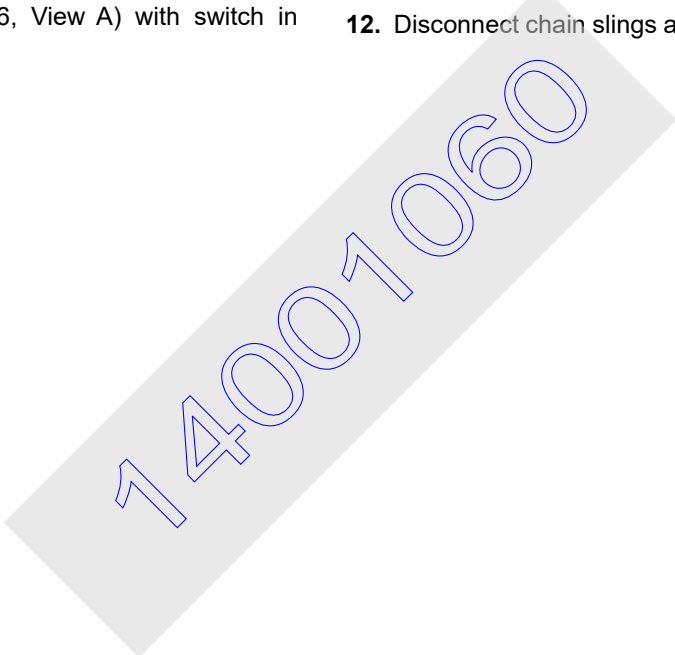


FIGURE 4-23

## Remove Boom Butt

See [Figure 4-23](#) for the following procedure.

1. Connect two legs of chain sling (3, View B) to lifting lugs (4) on boom butt (1).
2. Hoist just enough to support boom butt with chain sling.
3. Unpin locking cover (5, View A) and rotate it down.
4. Fully disengage boom hinge pins (6, View A) with switch in operator's cab.
5. Remove shim on inboard side of both boom hinge lugs and store shims with boom butt.
6. Slowly travel crane in reverse and lower boom butt onto blocking (View C).
7. Disconnect chain sling from boom butt.
8. Engage boom hinge pins (6, View A) with switch in operator's cab.
9. Rotate locking cover (5, View A) up and pin it closed.
10. Lower wire rope guide (8) to stored position:
  - a. Remove pins (9, View D) from lower holes, raise platform (10) to stored position, and reinstall pins (9) in upper holes.
  - b. Attach two legs of chain sling to lifting lugs (11, View E) on wire rope guide (8).
  - c. Remove pins (12, View F) from lugs on boom butt (1).
  - d. Lower wire rope guide to stored position at front of butt.
  - e. Reinstall pins (12, View F) in boom butt.
11. Lift boom butt onto trailer. See Lifting Boom Butt topic on [Page 37](#) for instructions.
12. Disconnect chain slings and secure boom butt to trailer.



Legend for [Figure 4-23](#)

Item	Description	Item	Description
1	Boom Butt	8	Wire Rope Guide
2	Assembly Block	9	Pin with Hair-Pin Cotter (2)
3	4-Leg Chain Sling	10	Platform
4	Lifting Lug (rear) (2)	11	Lifting Lug (2)
5	Locking Cover with Snap Pins	12	Pin with Snap Pin (2)
6	Boom Hinge Pin (2)		
7	Guide Pin (2)		

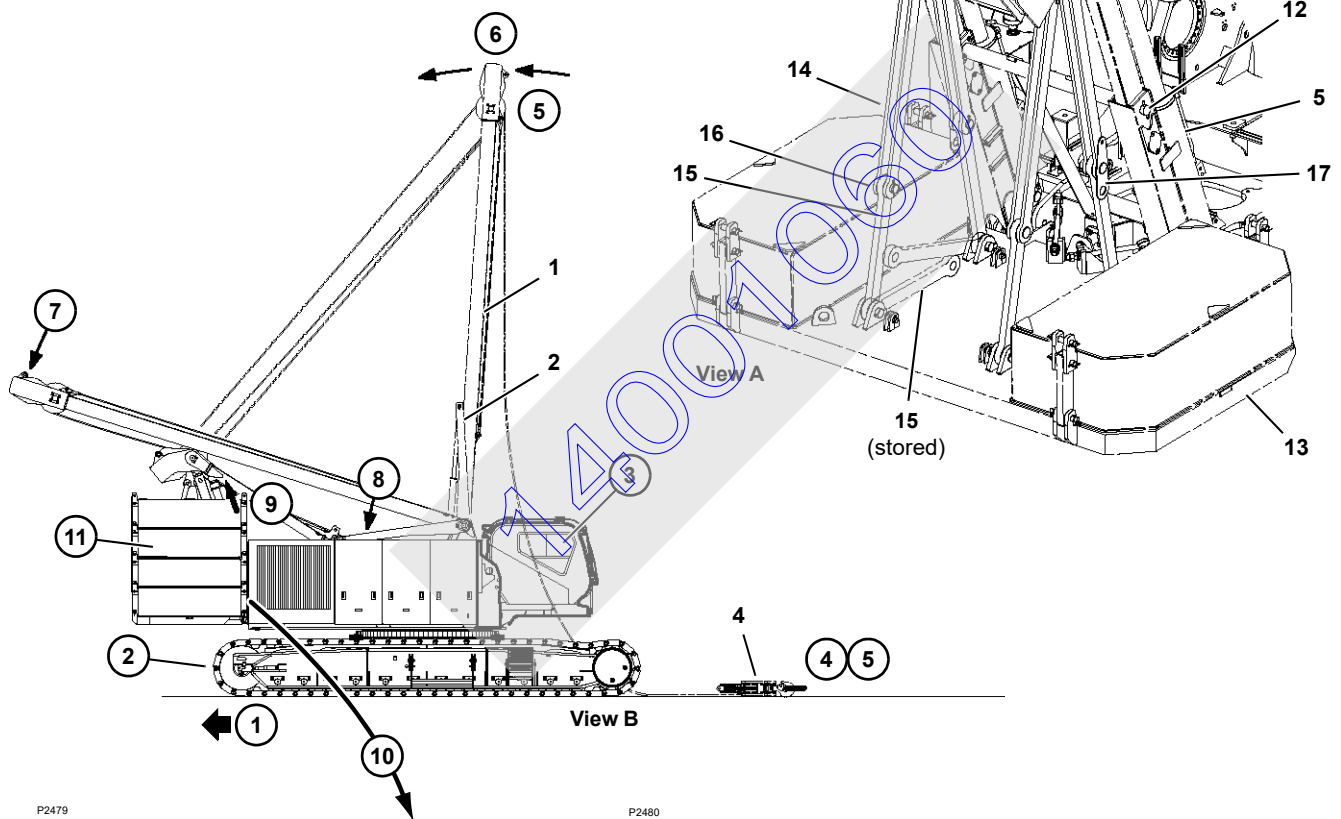
Numbers in parentheses equal quantity

14COM4129a  
14COM4130b

Item	Description	Item	Description
1	Mast	10	Stabilizer Rod (2)
2	Mast Arm (2)	11	Snap Pin (2)
3	Gantry	12	Backhitch Pin (2)
4	Assembly Block	13	Tray
5	Gantry Cylinder (2)	14	Upper Handling Strap (8)
6	Pocket (2)	15	Lower Handling Strap (4)
7	Lock Nut (2)	16	Pin with Cotter Pin (4)
8	Flange Nut (2)	17	Storage Link (2)
9	Bracket (2)		

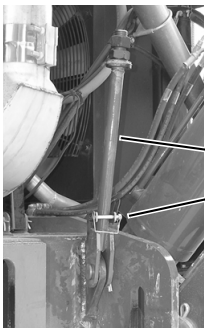
Numbers in parentheses equal quantity

Circled Numbers Correspond to REMOVE COUNTERWEIGHT Procedure

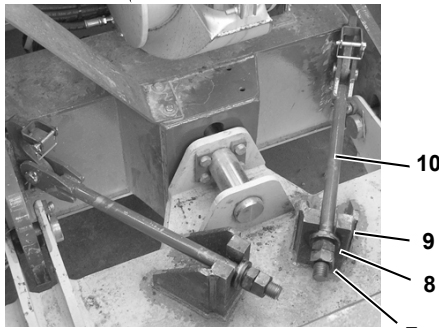


P2479

P2480



View D



View C

FIGURE 4-24

## Remove Counterweight

### Remove Crane Counterweight



#### **DANGER**

##### **Tipping Hazard!**

Prevent crane from tipping:

- Remove crane counterweight before removing carbody counterweight

##### **Moving Part/Crush Hazard!**

Avoid being crushed by moving parts:

- Do not stand on counterweight while it is being lowered
- Never go under counterweight while it is being lowered

##### **Falling Mast Hazard!**

Prevent mast from falling:

- Do not raise mast to vertical until mast arms are fully raised. Mast will fall over backwards if raised to vertical when arms are down

**NOTE:** If not already done, select Liftcrane Mast Capacities Chart in configuration screen of RCL display.

The mast and gantry controls will not operate properly and the mast operating limits will remain off until the proper capacity chart is selected.

See [Figure 4-24](#) for the following procedure.

1. Removal will be easier if rear of crane is slightly higher than front of crane — travel rear of crawlers onto blocking approximately 1 in (25 mm) high.
2. Remove step from carbody counterweight under crane counterweight.
3. Perform the following steps in the operator's cab:

- a. Turn off boom hoist (Drum 4) park switch.
- b. Turn on setup remote control in function mode screen of main display.
- c. If not already done, fully raise mast arms (2, View B) using switch in the operator's cab.

4. Lower assembly block (4, View B) onto the ground.
5. Disconnect load line from mast (1) and from assembly block (4) and lay load line on ground in front of crane.
6. BOOM UP slowly with boom hoist control to lower mast over center to rear. Pay out load line as required.
7. Stop lowering mast when it contacts gantry (View B).
8. Fully lower mast arms (2, View B) using switch in the operator's cab.
9. Fully extend gantry cylinders (5) with remote control until rods are snug against gantry pockets (6).



#### **WARNING**

##### **Falling Counterweight Hazard!**

Prevent counterweight from falling off crane:

- Do not attempt to lower counterweight until stabilizer rods are disconnected in step [10](#). Structural damage will occur, possibly causing tray to tip and counterweight boxes to fall off tray

10. Disconnect stabilizer rods:
  - a. Loosen lock nuts (7, View C) and flange nuts (8).
  - b. Pin stabilizer rods (10, View D) in shipping position with snap pins (11).
11. Remove cotter pins and disengage backhitch pins (12) with remote control. Keep pins disengaged until gantry is lowered (step [12](#)).

**Visually check that both backhitch pins are fully disengaged.**

14COM4129a  
14COM4130c  
14COM4131a

Item	Description	Item	Description
1	Mast	10	Stabilizer Rod (2)
2	Mast Arm (2)	11	Snap Pin (2)
3	Gantry	12	Backhitch Pin (2)
4	Assembly Block	13	Tray
5	Gantry Cylinder (2)	14	Upper Handling Strap (8)
6	Pocket (2)	15	Lower Handling Strap (4)
7	Lock Nut (2)	16	Pin with Cotter Pin (4)
8	Flange Nut (2)	17	Storage Link (2)
9	Bracket (2)		

Numbers in parentheses equal quantity

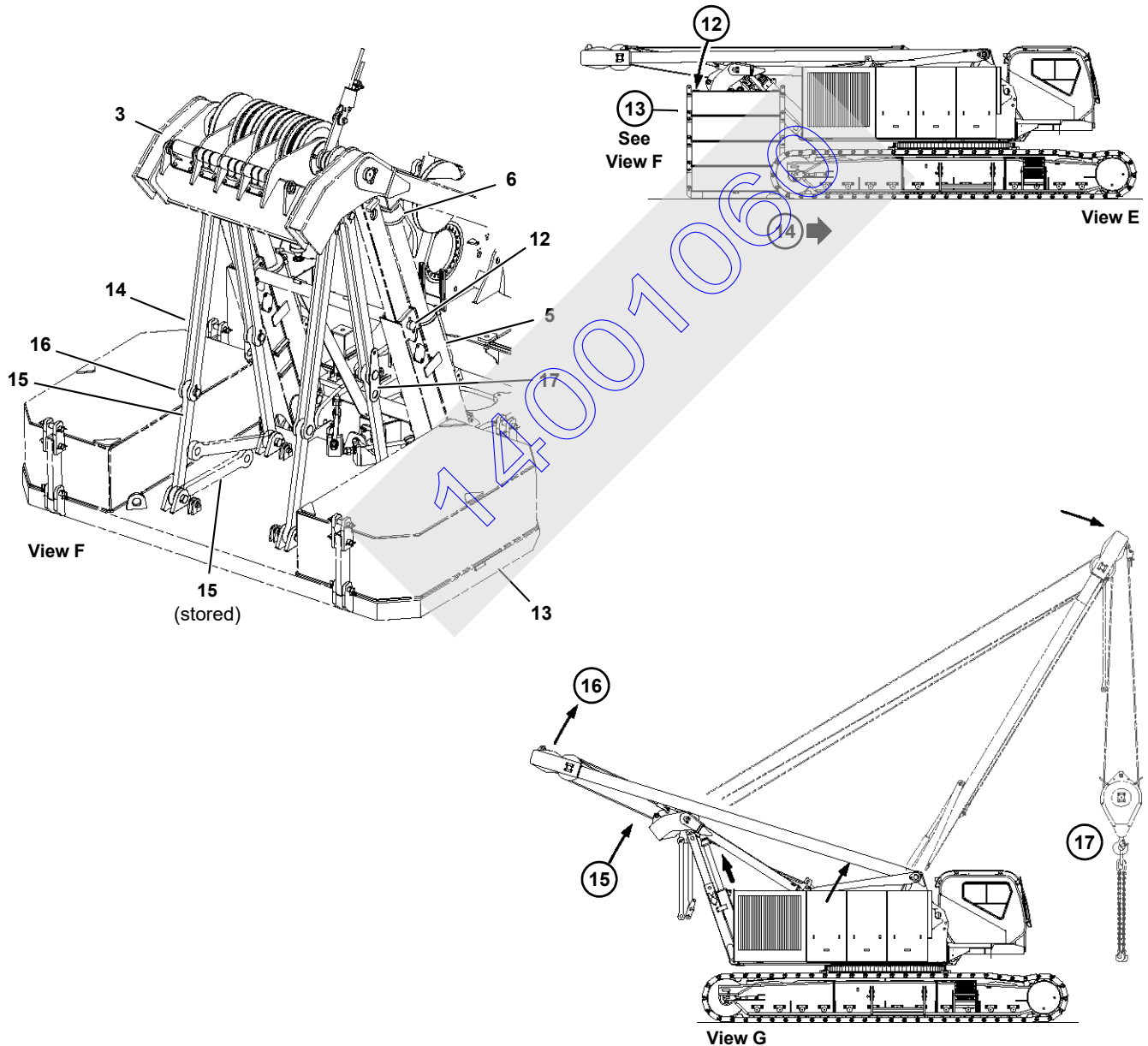


FIGURE 4-24 continued

**NOTE:** The mast will lower and rise automatically with the gantry during the remaining steps.

12. Lower gantry (View E) with remote control until counterweight tray (13) is on the ground and handling straps (14 and 15, View F) slacken.

13. Disconnect handling straps (View F):

a. Unpin handling straps (15) from handling straps (14) and lower handling straps (15) onto tray for storage.

b. Lower handling straps (14) to vertical.

Keep pins (16, View F) and storage links (17) pinned to handling straps (14).

14. Travel crane away from counterweights.

15. Raise gantry, as follows:

a. Disengage backhitch pins (12, View F) with remote control. Keep pins disengaged until gantry is fully raised.

**Visually check that both backhitch pins are fully disengaged.**

b. Raise gantry to working position with remote control (View G) — backhitch pin holes should be aligned.

c. Engage backhitch pins with remote control.

**Visually check that both backhitch pins are fully engaged.**

d. Install cotter pins in backhitch pins.

e. Do not retract gantry cylinders at this time. They can be extended for remaining procedures.

16. BOOM DOWN with boom hoist control to position mast in operating range.

The mast arms will rise automatically until they contact the mast. Then, the arms will continue to rise to raise the mast.

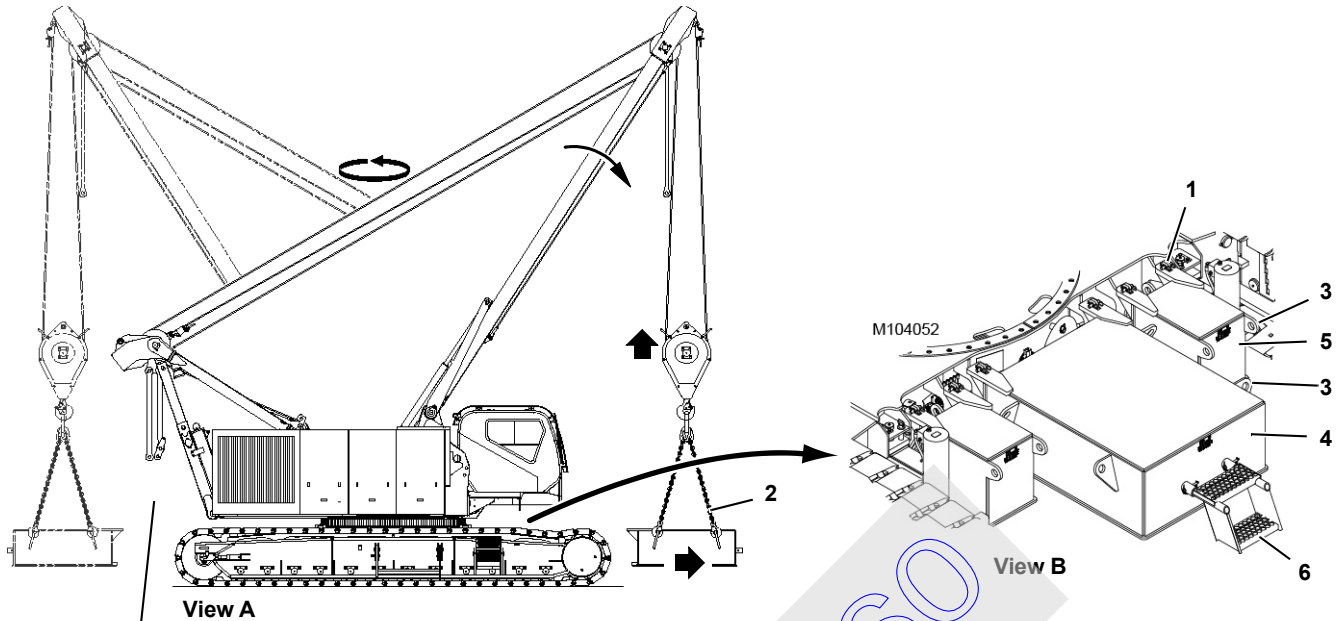
The mast arms will stop automatically when cylinders are fully extended (at approximately 120°).

**NOTE:** Engine speed will automatically decrease if the throttle is set at less than 1,300 RPM.

17. Reinstall assembly block and complete disassembly of crane.

14001000

14COM4190a



Remove crane counterweight before removing carbody counterweights.

Item	Description
1	Pin with Hair-Pin Cotter (2 each box)
2	Chain Sling
3	Lifting Lug
4	Carbody Counterweight (center)
5	Carbody Counterweight (side, Series 3 only)
6	Step with Quick-Release Pins 47 lb (21 kg)

FIGURE 4-25



**DANGER****Falling Load Hazard!**

Prevent structural failure of components:

- Do not exceed lifting capacities given in Liftcrane Mast Capacities Chart at the end of this section

The 14000 must be in the following configuration to assemble and remove the carbody counterweights and to disassemble the crane counterweight:

- Crane on a firm uniformly supporting surface that is level to within 1% grade — 1 ft (0,3 m) in 100 ft (30,5 m)
- Liftcrane Mast Capacities Chart selected in configuration screen of RCL display
- Mast arms fully raised
- Assembly block and 4-leg chain sling installed
- Mast operated between fully extended mast arms and 145° — 26 ft (7,9 m radius)
- Loads limited to those given in Liftcrane Mast Capacities Chart at the end of this section

**Remove Carbody Counterweights**

If equipped with Series 2 or Series 3 counterweight, **remove crane counterweight before removing carbody counterweights.**

Remove the carbody center counterweight first if equipped with Series 3 counterweight. Then remove the carbody side counterweights.

See [Figure 4-25](#) for the following procedure.

1. Remove and store step (6, View B). The step can be turned upside down and re-pinned to the counterweight for storage.
2. Remove pins (1, View B).
3. Attach hooks from chain sling (2, View A) to lifting lugs (3, View B) on carbody counterweight (4).

4. Boom, swing, and hoist as required to disengage carbody counterweight from lugs on carbody (View B).
5. Place carbody counterweight on the ground for storage or lift it onto a trailer for shipping.
6. Disconnect chain sling from carbody counterweight.
7. If carbody counterweight is being shipped, secure it to trailer.
8. Store pins (1, View B) in lugs on carbody.
9. For Series 3, repeat steps for each carbody side counterweight (5).
10. Swing 180° and repeat steps at other end of carbody.

**Disassemble Crane Counterweight****WARNING****Falling Load Hazard!**

Prevent lifting lugs from breaking and counterweights from falling:

- Do not lift more than two side boxes at a time
- Do not lift tray with side boxes installed
- Do not lift tray with center box installed

To disassemble the crane counterweight, reverse Assemble Counterweight steps on [Page 4-31](#).

**Disassemble Jib and Boom**

- To disassemble the jib, see Jib Removal procedure on [Page 4-96](#).
- To disassemble the boom, see Boom Removal procedure on [Page 4-85](#).

**Remove Platforms**

To store the platforms, reverse Install Platforms procedure on [Page 4-29](#).

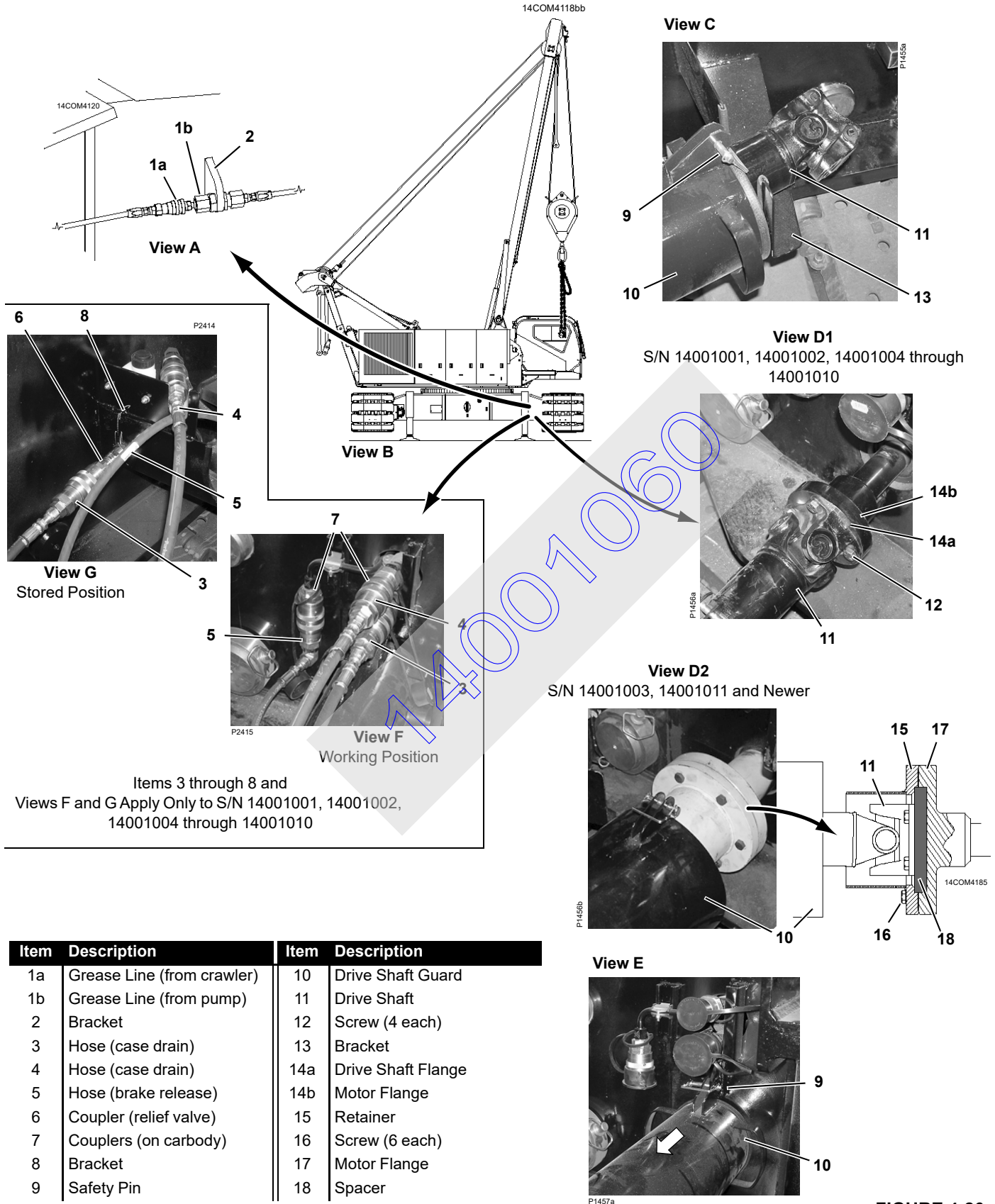


FIGURE 4-26

## Remove Crawlers

See [Figure 4-26](#) for the following procedure.

1. Rotate each crawler step in and down from working position to stored position.

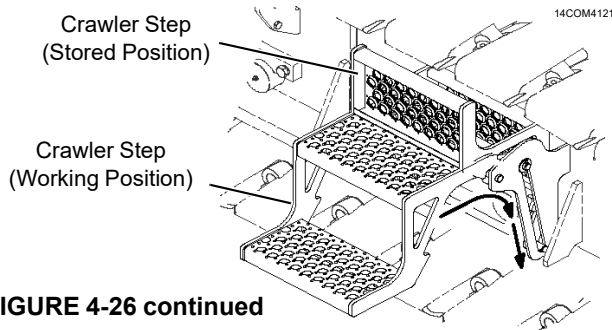


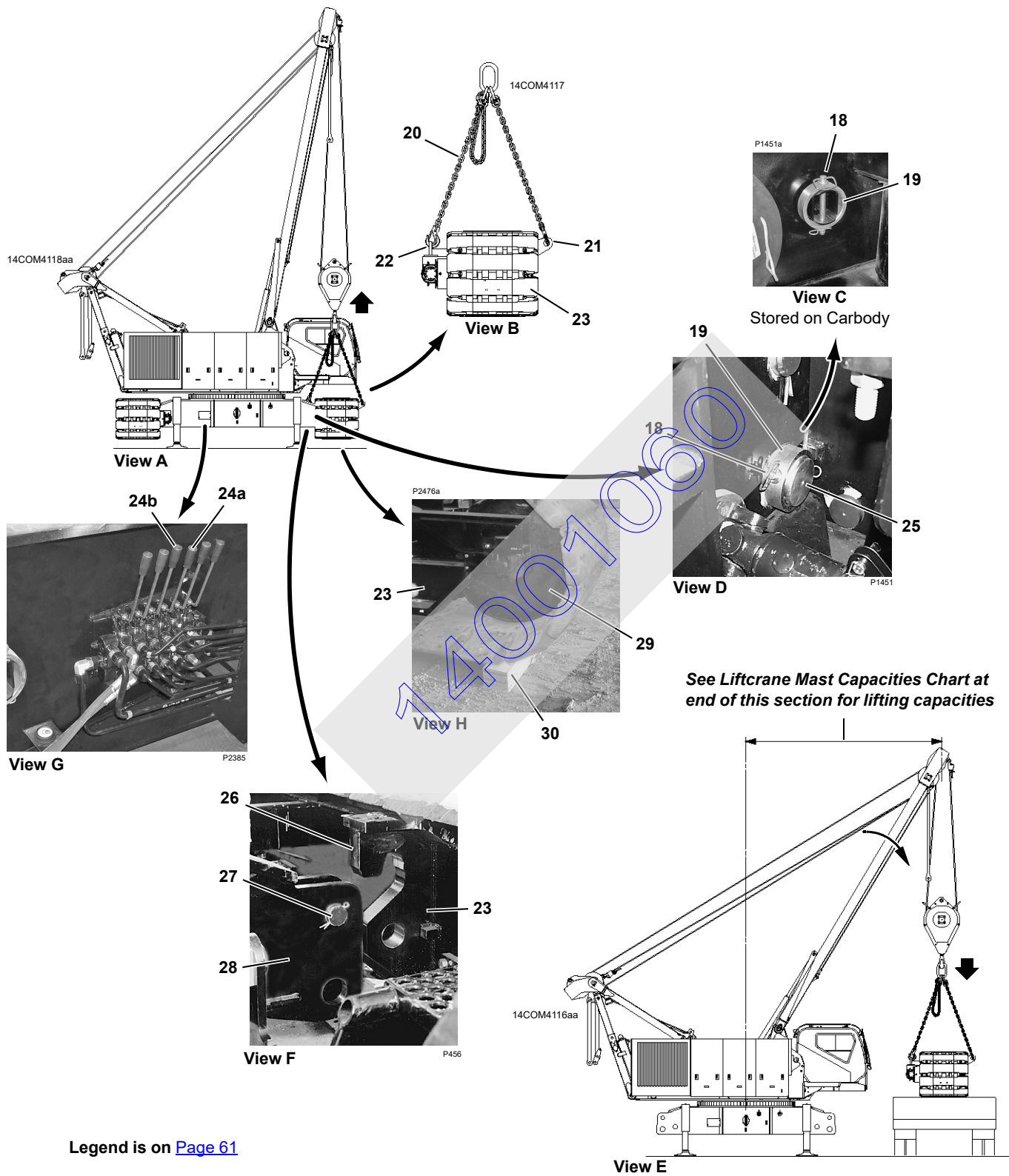
FIGURE 4-26 continued

2. If equipped with automatic crawler lube system, disconnect each grease line (1a, View A) from (1b) at bracket (2) on carbody.

### CAUTION Parts Damage

To avoid damage to travel brakes on S/N 14001001, 14001002, and 14001004 through 14001010, hydraulic hoses must be connected in stored position (View G) when shipping crawlers.

3. For S/N 14001001, 14001002, and 14001004 through 14001010, disconnect and store travel brake hydraulic hoses in following order at both crawlers:
  - a. Disconnect hydraulic hose (3, View F) from coupler (7) on carbody.
  - b. Connect hydraulic hose (3, View G) to coupler (6) on crawler.
  - c. Disconnect hydraulic hoses (4 and 5, View F) from couplers (7) on carbody.
  - d. Connect hydraulic hoses (4 and 5, View G) to each other and lay in slot of bracket (8).
4. For S/N 14001001, 14001002, and 14001004 through 14001010, perform following steps at both crawlers:
  - a. Remove pin (9, View E) and slide guard (10) away from carbody to expose drive shaft (11, View D1).
  - b. Remove screws (12, View D1).
  - c. Lift drive shaft (11, View C) onto bracket (13).
  - d. Apply a coat of light oil or rust inhibitor to mating surfaces of drive shaft flanges.
  - e. Install screws (12, View D1) in motor flange (14b) holes.
  - f. Install pin (9, View C) in guard (10) holes.
5. For S/N 14001003, 14001011 and newer, perform the following steps at both crawlers:
  - a. Remove pin (9, View E) and slide guard (10) away from carbody to expose retainer (15, View D2).
  - a. Remove screws (16, View D2).
  - b. Slide retainer (15, View D2) onto drive shaft (11).
  - c. Lift drive shaft (11, View C) onto bracket (13).
  - d. Apply a coat of light oil or rust inhibitor to mating surfaces of retainer (15), spacer (18), and motor flange (17).
  - e. Install screws (16, View D2) in motor flange (17) holes.
  - f. Install pin (9, View C) in guard (10) holes.
6. Position each carbody jack as follows (see [Figure 4-8](#)):
  - a. Remove hitch pin (7, View E).
  - b. Swing jack out (View F).
  - c. Install hitch pin (7).
  - d. Remove jack pads (8, View D) and attach to jacks (8, View F).
7. Using controls on front of carbody (View A, [Figure 4-8](#)), extend all four jacks until crawler treads are just clear of the ground. **Keep crane level while jacking.**



Legend is on [Page 61](#)

FIGURE 4-26 continued



**DANGER**

**Falling Load Hazard!**

Prevent structural failure of components while handling either crawler with mast:

- Make sure crane is level. Check level on front of carbody. Adjust jacks as required
- Do not swing 15° either side of center (Figure 4-27)
- Do not exceed lifting capacities given in Liftcrane Mast Capacities Chart at end of this section

Swing Diagram

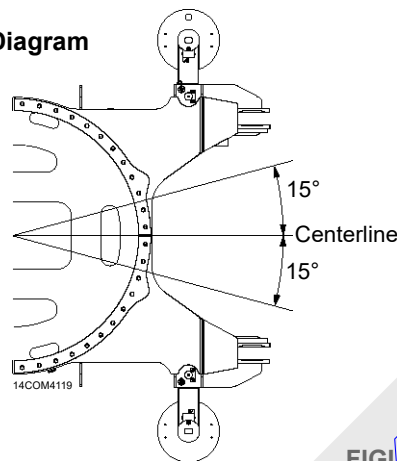


FIGURE 4-27

8. Remove hitch pin (18, View D) and collar (19) from all four connecting pins.
9. Store collars and hitch pins as shown in View C.
10. Attach three hooks from chain sling (20, View B) to lifting links (21) on outboard side of desired crawler (23) and to lifting lug (22) on inboard side of crawler.
11. Using crawler pins control (View G), retract crawler connecting pins (25, View D) for crawler being removed.

**NOTE:** The connection between the crawler frame and carbody can bind during operation. This binding will

make it extremely hard to lift the crawler away from the carbody. To break the binding, perform step 12.

12. Break binding in connection between crawler and carbody:
  - a. Install blocking (30, View H) snugly between the ground and both ends of crawler — under roller (30) at one end and under tumbler at other end.
  - b. While one person operates carbody jacks, have two assistants watch connections between crawler frame and carbody (one each end).
  - c. Lower crawler onto blocking by slowly retracting both carbody jacks next to crawler being removed.
  - d. STOP when assistants signal that both connections have been broken between crawler frame and carbody.

**Retract jacks only enough to break binding. Do not allow crawler to disengage carbody.**

  - e. Extend jacks to level carbody, and remove blocking from under crawler.
13. Slowly hoist, mast up, and swing as required to disengage crawler hooks (26, View F) from fixed pins (27) in carbody (28).
14. Place crawler on ground for storage or place it on trailer (View E) for shipping.
15. Disconnect chain sling from crawler.
16. Securely attach crawler to trailer.



**DANGER**

**Tipping Hazard!**

Prevent crane from tipping:

- Do not swing in step 17 until mast is raised to 118° or higher
17. Raise mast to 118° or higher, swing 180°, and repeat steps 10 – 16 for other crawler.

Legend for [FIGURE 4-26 continued](#)

Item	Description	Item	Description	Item	Description
18	Hitch Pin with Hair Pin Cotter	23	Crawler	27	Fixed Pin
19	Collar	24a	Left Crawler Pins Control	28	Carbody
20	Chain Sling (4 leg)	24b	Right Crawler Pins Control	29	Roller or Tumbler
21	Lifting Link	25	Crawler Connecting Pin	30	Blocking
22	Lifting Lug	26	Hook		



Circled Numbers Correspond to  
**LOWER MAST**  
Procedure

Item	Description
1	Mast Arm(2)
2	Mast
3	Gantry
4	Gantry Cylinder (2)
5	Pocket (2)
6	Backhitch Pin (2)
7	Backhitch
8	Handling Strap (8)
9	Storage Link (2)
10	Stud with Cotter Pin (2)
11	Pin with Cotter Pin (2)

Numbers in parentheses equal quantity

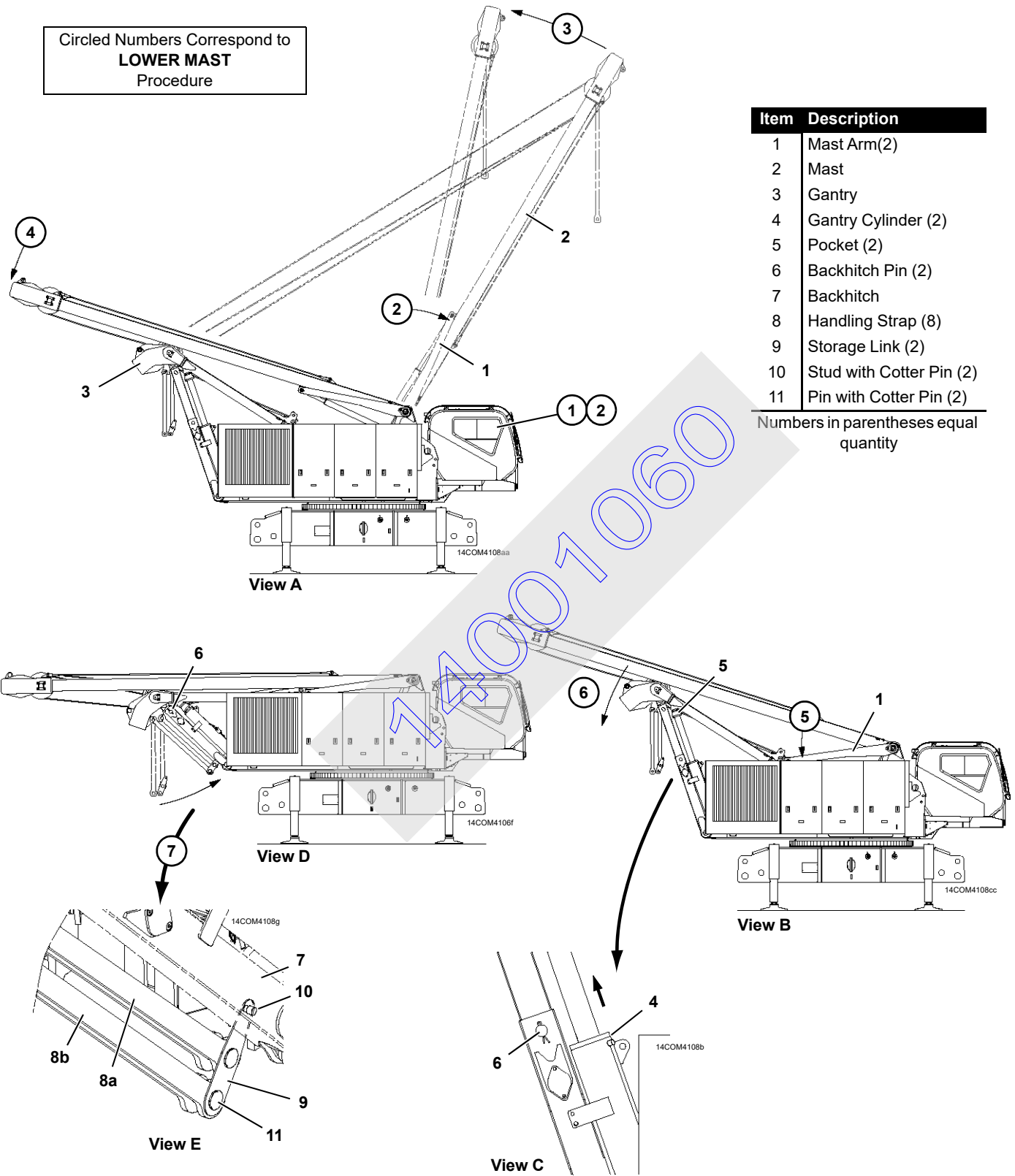


FIGURE 4-28

## Remove Assembly Block

See Remove Assembly Block steps on [Page 4-41](#).

## Lower Mast to Transport Position

See [Figure 4-28](#) for the following procedure.

1. If not already done, perform the following steps in operator's cab:
  - a. Select Liftcrane Mast Capacities Chart in configuration screen of RCL display.  
The mast and gantry controls will not operate properly and the mast operating limits will remain off until the proper capacity chart is selected.
  - b. Turn on setup remote control in function mode screen of main display.
  - c. Turn off boom hoist (Drum 4) park switch.
2. If not already done, fully raise mast arms (1, View A) using switch in operator's cab.



### DANGER

#### Falling Mast Hazard!

Prevent mast from falling:

- Do not raise mast to vertical until mast arms are fully raised. Mast will fall over backwards if raised to vertical when arms are down
3. BOOM UP (with boom hoist control in cab) to raise mast (2) over center to rear.
  4. Stop raising mast when it contacts gantry (View A).

5. Fully lower mast arms (1, View B) using switch in operator's cab.

**NOTE:** During step 6, the following will occur:

- Mast will lower with gantry
- Boom hoist wire rope will haul in automatically
- Mast arms will remain down

6. Lower gantry, as follows:

- a. Fully extend gantry cylinders (4, View C) with remote control until cylinder rods are snug against pockets (5, View B) in gantry.

- b. Remove cotter pins from backhitch pins (6, View C).

- a. Disengage backhitch pins with remote control. Keep pins disengaged until gantry is fully lowered.

**Visually check that both backhitch pins are fully disengaged.**

- b. Lower gantry to transport position (View D) with remote control — backhitch pin holes should be aligned.

- c. Engage backhitch pins with remote control.

**Visually check that both backhitch pins are fully engaged.**

- d. Install cotter pins in backhitch pins.

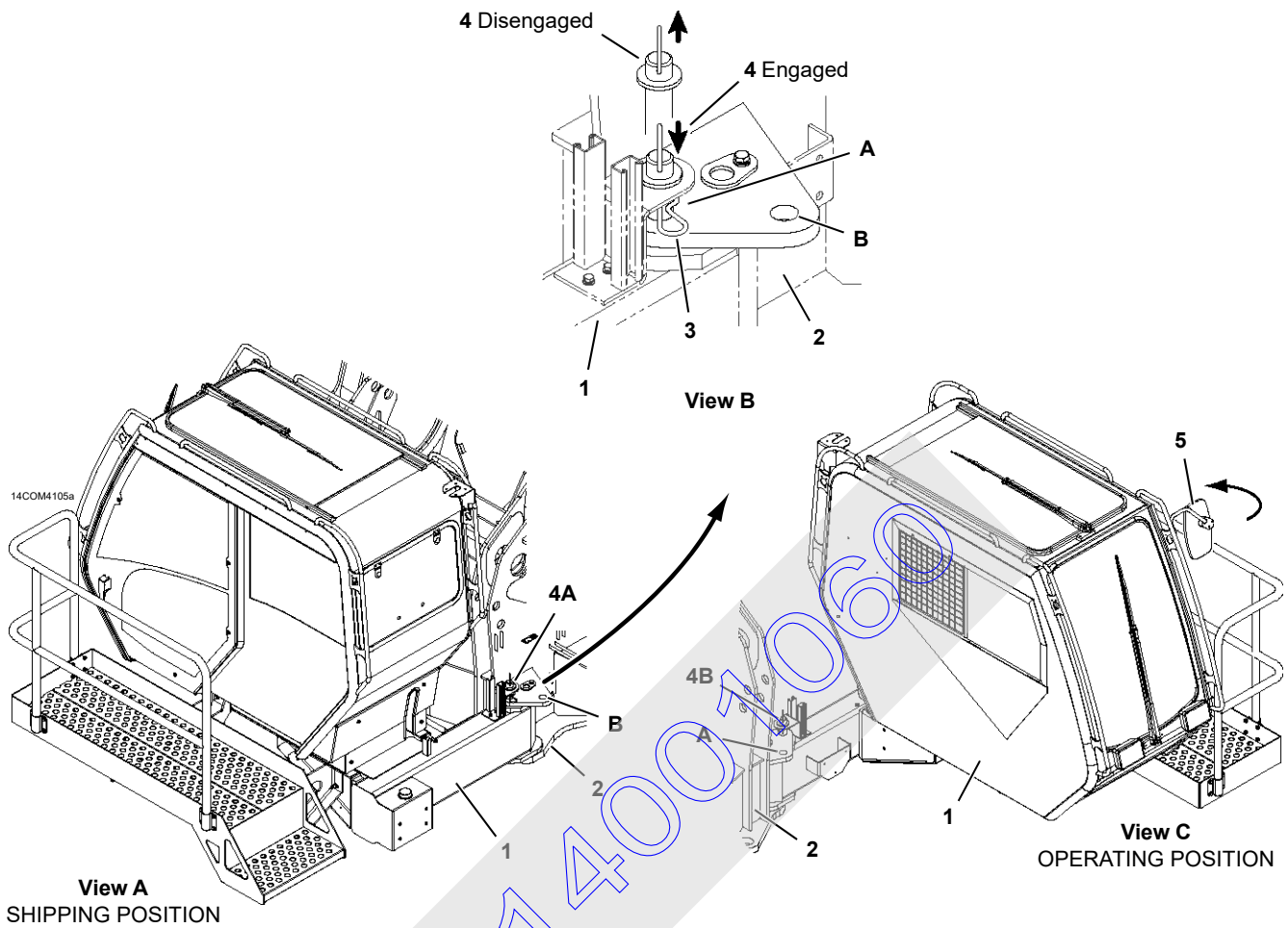
7. Store handling straps (View E):

- a. Rotate handling straps (8a) to storage position and fasten storage links (9) to studs (10) with cotter pins.

- b. Remove pins (11) handling straps (8b).

- c. Rotate handling straps (8b) to storage position and pin them to storage links (9) with pins (11).





Item	Description
1	Operator's Cab
2	Rotating Bed
3	Hair-Pin Cotter
4	Hitch Pin
5	Mirror
A	Shipping Hole
B	Operating Hole

Past Production Cab Shown. Current Production Cab Similar.

FIGURE 4-29

## Install Protective Covers on Cab Windows

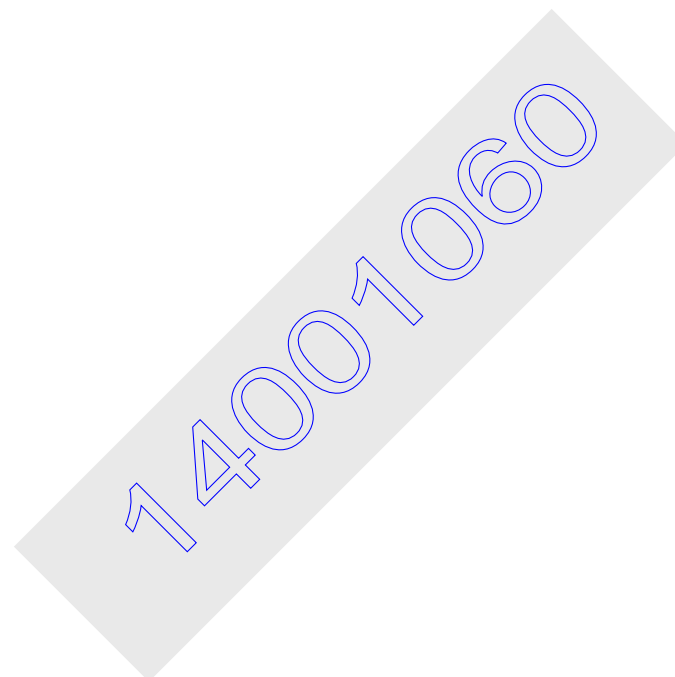
If equipped, install optional protective covers on windows of operator's cab (see [Figure 4-7](#)).

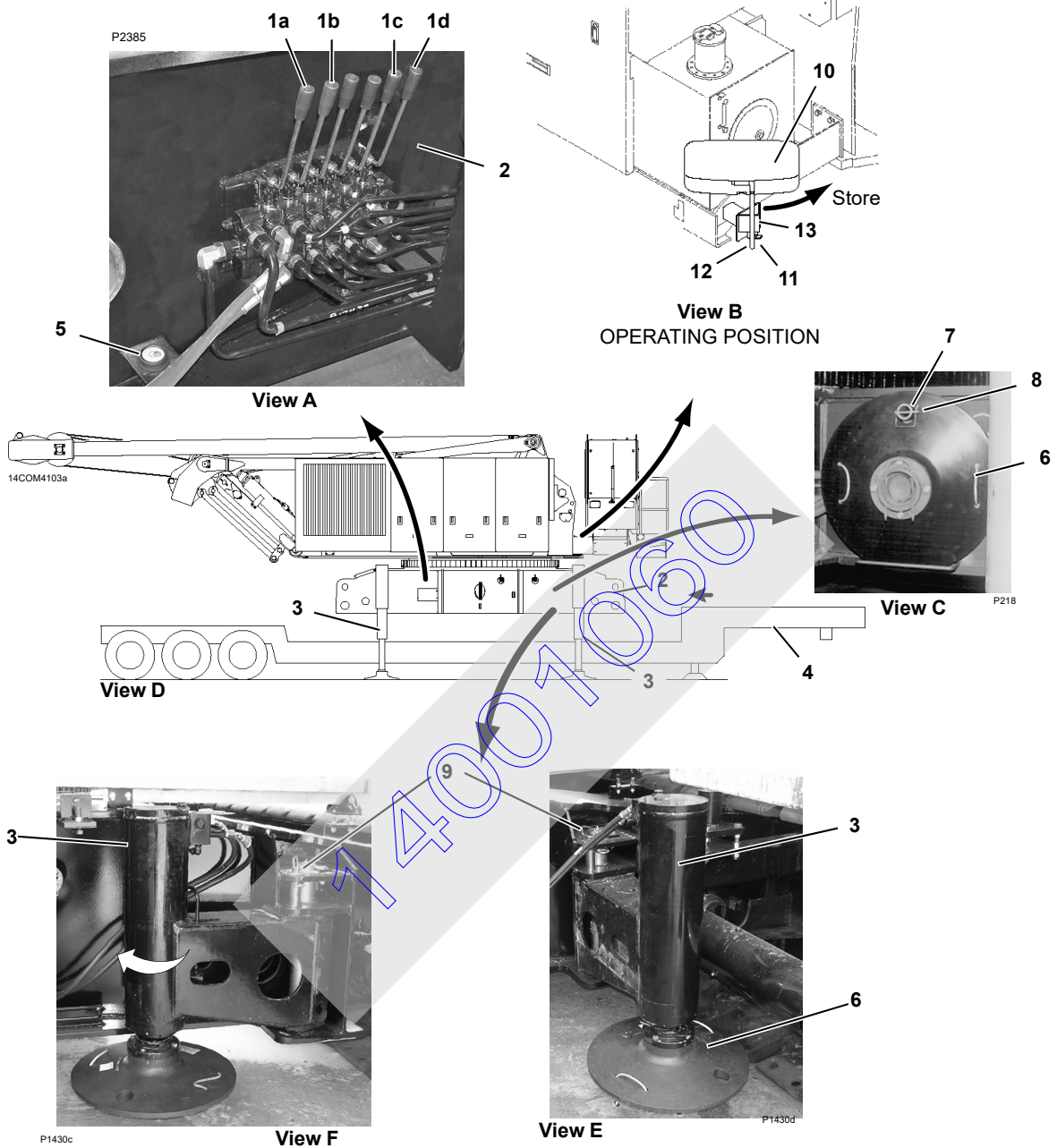
## Store Operator's Cab

See [Figure 4-29](#) for the following procedure.

Rotate operator's cab (1) to shipping position as follows:

1. Rotate mirror (5, View C) inward against cab for shipping.
2. Remove hair-pin cotter (3, View B) from top retaining hole in hitch pin (4).
3. Raise hitch pin (4, View B) to disengaged position (bottom retaining hole visible) and reinstall hair-pin cotter (3).
4. Rotate cab (1) 90° to shipping position (View A).
5. Remove hair-pin cotter (3, View B) and lower hitch pin (4) to engaged position.
6. Reinstall hair-pin cotter (3, View B).





Item	Description	Item	Description
1a	Right Front Carbody Jack Control	6	Jack Pad
1b	Right Rear Carbody Jack Control	7	Storage Lug
1c	Left Rear Carbody Jack Control	8	Snap Pin
1d	Left Front Carbody Jack Control	9	Hitch Pin with Hair-Pin Cotter
2	Carbody	10	Mirror
3	Jack	11	Thumb Screw
4	Trailer	12	Support
5	Level	13	Bracket

FIGURE 4-30

## Install Crane on Trailer

See [Figure 4-30](#) for the following procedure.



### WARNING

#### Moving Part Hazard!

Avoid serious crushing injury:

- Warn all personnel to stand clear of jacks

#### Tipping Hazard!

Avoid tipping crane over:

- Keep crane level while jacking

1. Using controls (1, View A) on front of carbody (2), extend jacks (3, View D) until carbody is high enough for trailer (4) to be traveled under crane.

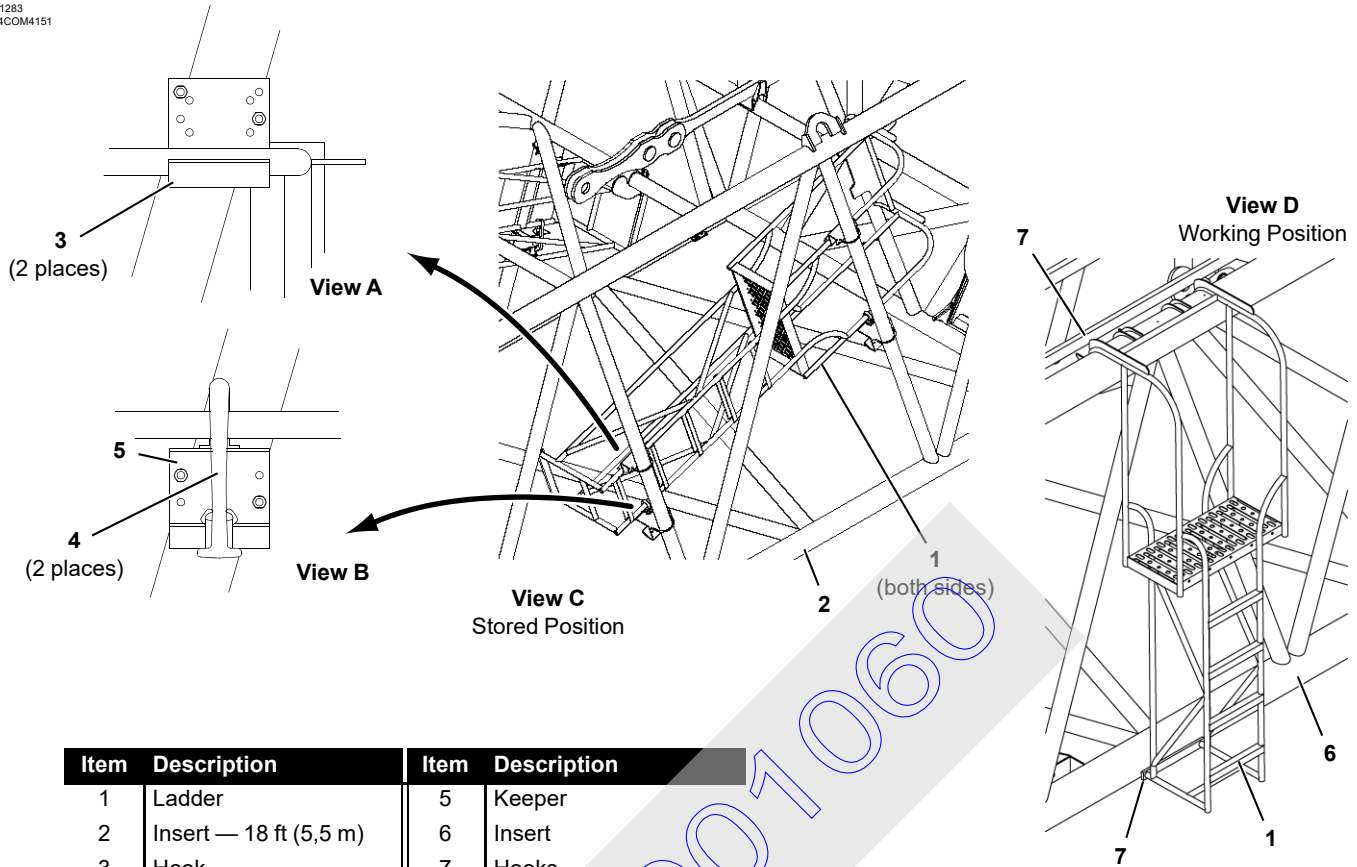
**Keep crane level while jacking.** Level (5, View A) is located near controls.

2. Position trailer under crane.

3. Retract jacks (3) to lower crane onto trailer.
4. Remove jack pads (6, View E) from jacks and store jack pads (View C).
5. Store each jack (3) as follows:
  - a. Fully retract jack.
  - b. Remove hitch pin (9, View E).
  - c. Swing jack in (View F).
  - d. Install hitch pin (9, View F).
6. Securely fasten carbody (2) to trailer (4).
7. Store mirror (10, View B) on right front corner of rotating bed:
  - a. Loosen thumb screw (11).
  - b. Lift mirror support (12) out of outer notch in bracket (13).
  - c. Rotate mirror inward and lower mirror support (12) into inner notch in bracket (13).
  - d. Tighten thumb screw (11).

14001060

A1283  
14COM4151



Item	Description	Item	Description
1	Ladder	5	Keeper
2	Insert — 18 ft (5,5 m)	6	Insert
3	Hook	7	Hooks
4	Rubber Latch	8	Pad

FIGURE 4-31

## BOOM LADDER

See [Figure 4-31](#) for the following procedure.

### WARNING

#### To Prevent Serious Injury or Death:

- Limit load on ladder to 300 lb (136 kg)
- Avoid improper use. This ladder is intended for use only on Manitowoc #76 boom inserts. Any other use is prohibited
- Use ladder for boom assembly/disassembly and maintenance only when boom is horizontal
- Make sure ladder is properly secured to insert
- When climbing ladder, hands shall be free of any objects. Objects which cannot be carried in pockets or tool belts must be lifted into place onto ladder platform prior to climbing ladder
- Stand only on platform. Do not stand on cross braces

## General

Optional ladders are stored inside insert (2) as shown in View C.

The ladders are designed for use in assembly/disassembly and maintenance of #76 boom sections and components. Each ladder weighs approximately 18 lb (8 kg).

## Removing Ladders from Storage

It is recommended that two people remove the ladder from the insert: one person inside insert to unlatch and lift ladder and another person outside of insert to help guide ladder out of insert. Use the following procedure:

1. Lower boom onto blocking at ground level. *Boom sections must be horizontal.*
2. Unhook rubber latches (4, View B).
3. Lift ladder (1, View C) up and out of hooks (3, View A).
4. Guide ladder through lacings to outside of insert.

## Using Ladders

Lift ladder (1, View D) to desired outside location on insert (6).

Ladder must be securely hooked over backside of upper chord and lower pads (8) must rest firmly against lower chord.

Ladder must hang vertically against insert when in use.

## Storing Ladders

It is recommended that two people store the ladder in the insert: one person outside of insert to help guide ladder into insert and another person inside insert to lift ladder and latch it in position. Use the following procedure:



### WARNING

#### Falling Load Hazard!

Ladders must be properly stored to prevent them from falling out of butt when boom is raised.

1. Hang ladder rails over hooks (3, View A) inside insert.
2. Pull rubber latches (4, View B) tightly over lower rail and latch to keepers (5).
3. Make sure ladder cannot move once latched in place.

## BOOM AND JIB RIGGING

### Assist Crane Requirements

Either the 14000 live mast or an assist crane can be used to handle, assemble, and disassemble the boom and jib components. See Crane Weights in Section 1 for weights of boom and jib components.



### DANGER

#### Falling Load Hazard!

Prevent structural failure of components:

- Do not exceed lifting capacities given in Liftcrane Mast Capacities Chart at the end of this section

The 14000 must be in the following configuration to assemble its own boom and jib:

- Gantry fully raised and backhitch pins engaged
- Mast arms fully raised
- Assembly block installed
- Liftcrane Mast Capacities Chart selected in configuration screen of RCL display
- Mast operated between fully extended mast arms and 145° — 26 ft (7,9 m radius)
- Loads limited to those given in Liftcrane Mast Capacities Chart at end of this section

### Blocked Crawlers

To prevent crane from tipping, some boom and jib lengths must be raised and lowered over blocked crawlers. See capacity charts for blocked crawler requirements and Crawler Blocking Diagram in Capacity Chart Manual for instructions.



### DANGER

#### Tipping Hazard!

Do not attempt to raise or lower boom and jib from or to the ground until crawlers are blocked, if required. Otherwise, crane will tip.

## Handling Components

Handle boom and jib sections with care to avoid damaging lacings and chords. All boom sections have lifting lugs as shown in [Figure 4-33](#).



### WARNING

#### Falling Load Hazard!

Lifting lugs on each insert are designed only for lifting that insert. Do not attempt to lift two or more inserts with lifting lugs on one insert. Lifting lugs may break allowing inserts to fall.

---

When lifting lugs are not used (as in the case of jibs):

- Lift against chords only, never against lacings

- Use nylon lifting slings. If wire rope or chain slings are used, install protective covering (such as sections of rubber tire) between slings and chords

***Boom handling with mast pendants pinned to lifting lugs on boom butt must be limited to boom length given in Boom Assembly Drawing.***



### WARNING

#### Falling Boom Hazard!

Do not attempt to handle more boom with mast than specified on Boom Assembly Drawing. Structural failure of components can occur, possibly allowing boom to fall.

---

## Assembly Drawings

Boom and jib components (top, inserts, butt, straps) must be assembled in proper sequence according to applicable Boom and Jib Assembly Drawings at the end of this section.

14001060



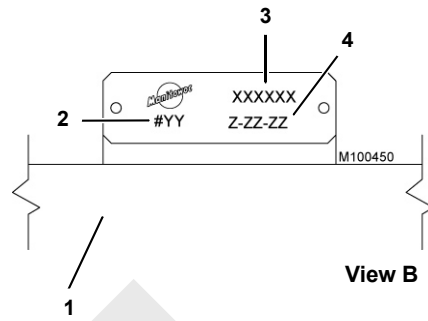
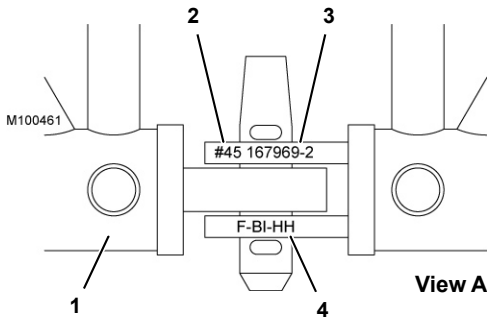
### Identifying Boom and Jib Components

Boom and jib sections are marked for proper identification as shown in Views A and B, [Figure 4-32](#).

Boom and jib pendants are marked for proper identification as shown in View C, [Figure 4-32](#).

Boom straps and links are marked for proper identification as shown in View D, [Figure 4-32](#).

**NOTE:** The markings shown in [Figure 4-32](#) can vary depending on when your crane was produced and the original equipment manufacturer.



Item	Description
1	Boom or Jib Chord
2	Boom or Jib Number
3	Manitowoc Part Number
4	Manitowoc Manufacturing Code
5	Pendant
5a	Aluminum Tag (if equipped)
6	Manitowoc Purchase Order Number
7	Manufacturer's Number
8	Wire Rope Type
9	Diameter
10	Length
11	Set Number
12	Strap or Link

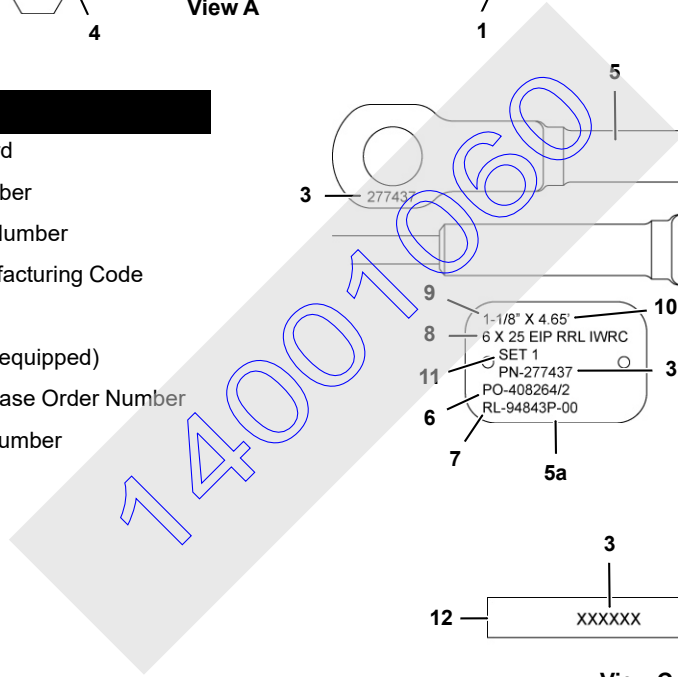
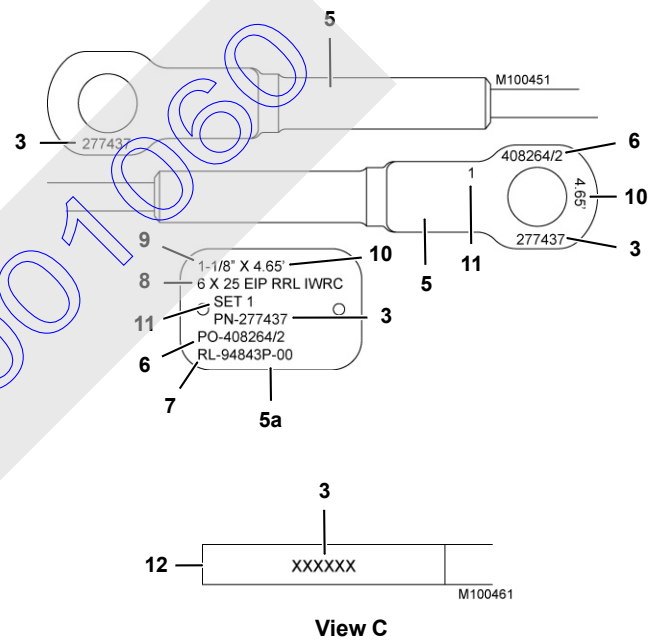


FIGURE 4-32

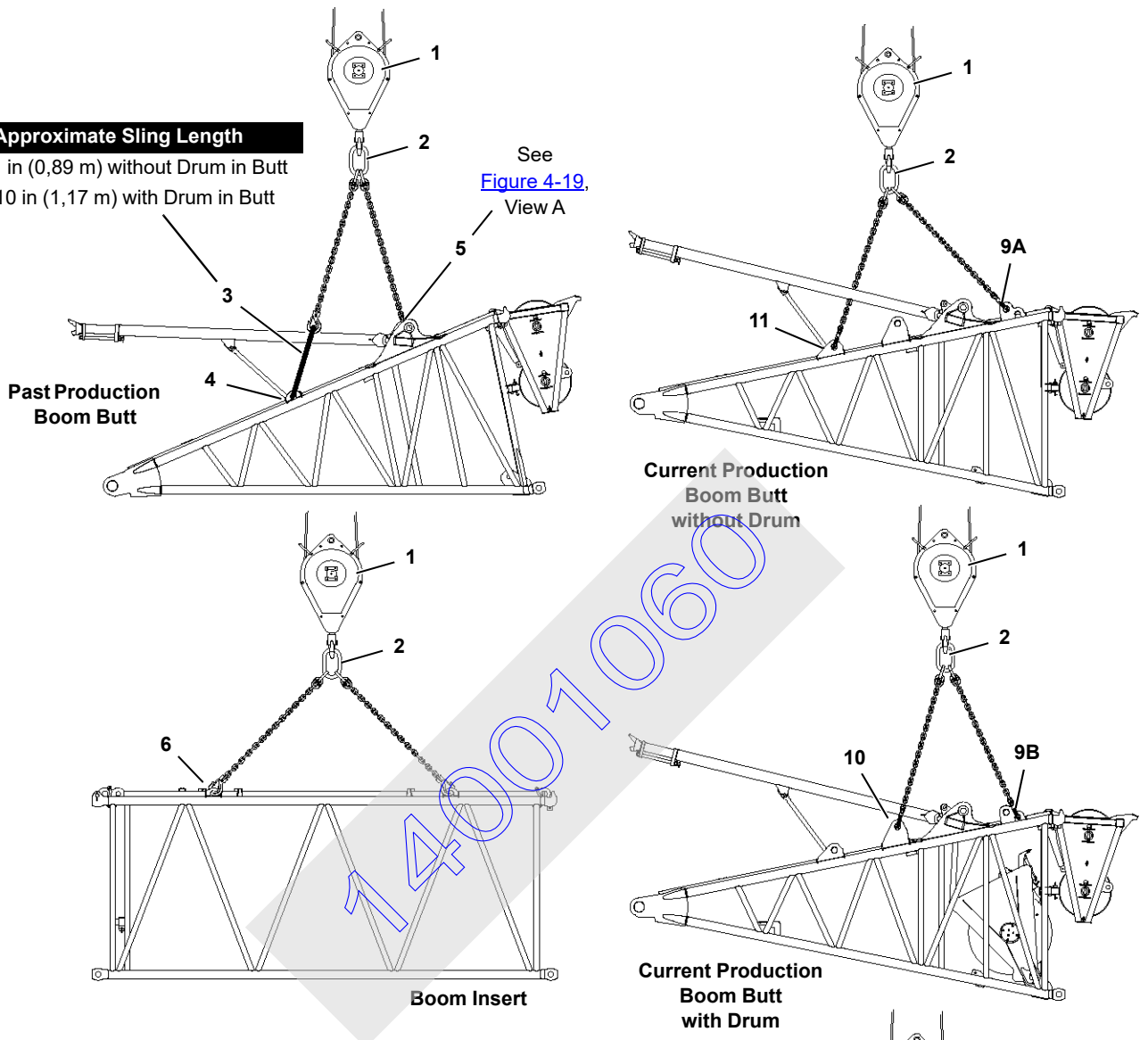
**THIS PAGE INTENTIONALLY LEFT BLANK**

14001060

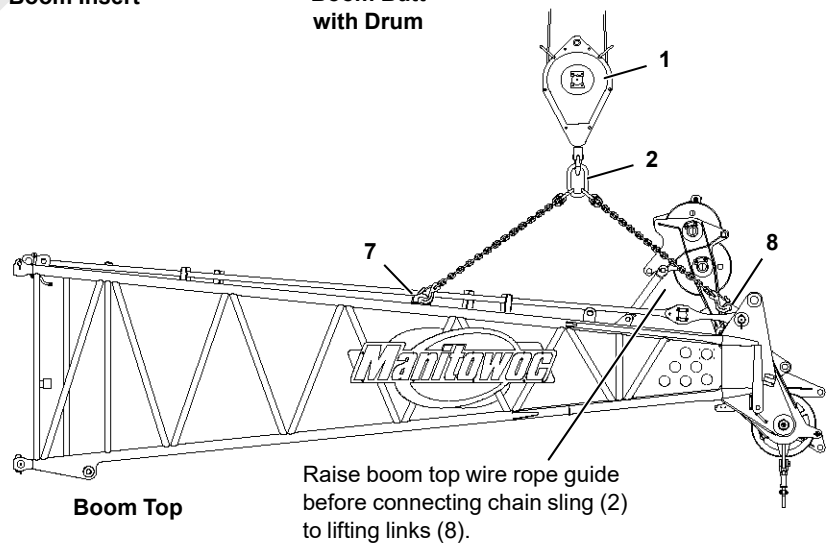
14COM4192

**Approximate Sling Length**  
 2 ft 11 in (0,89 m) without Drum in Butt  
 3 ft 10 in (1,17 m) with Drum in Butt

See [Figure 4-19, View A](#)



Item	Description
1	Assembly Block
2	Chain Sling (4-leg)
3	Lifting Sling (user furnished)
4	Lifting Lug on Chord (2)
5	Lifting Lug on Cross Beam (2)
6	Lifting Lug on Chord (1 or 2)
7	Lifting Lug on Chord (2)
8	Lifting Link (2)
9	Front Lug on Chord (2)
10	Middle Lug on Chord (2)
11	Rear Lug on Chord (2)
A	Top Hole
B	Bottom Hole



**FIGURE 4-33**

**4**

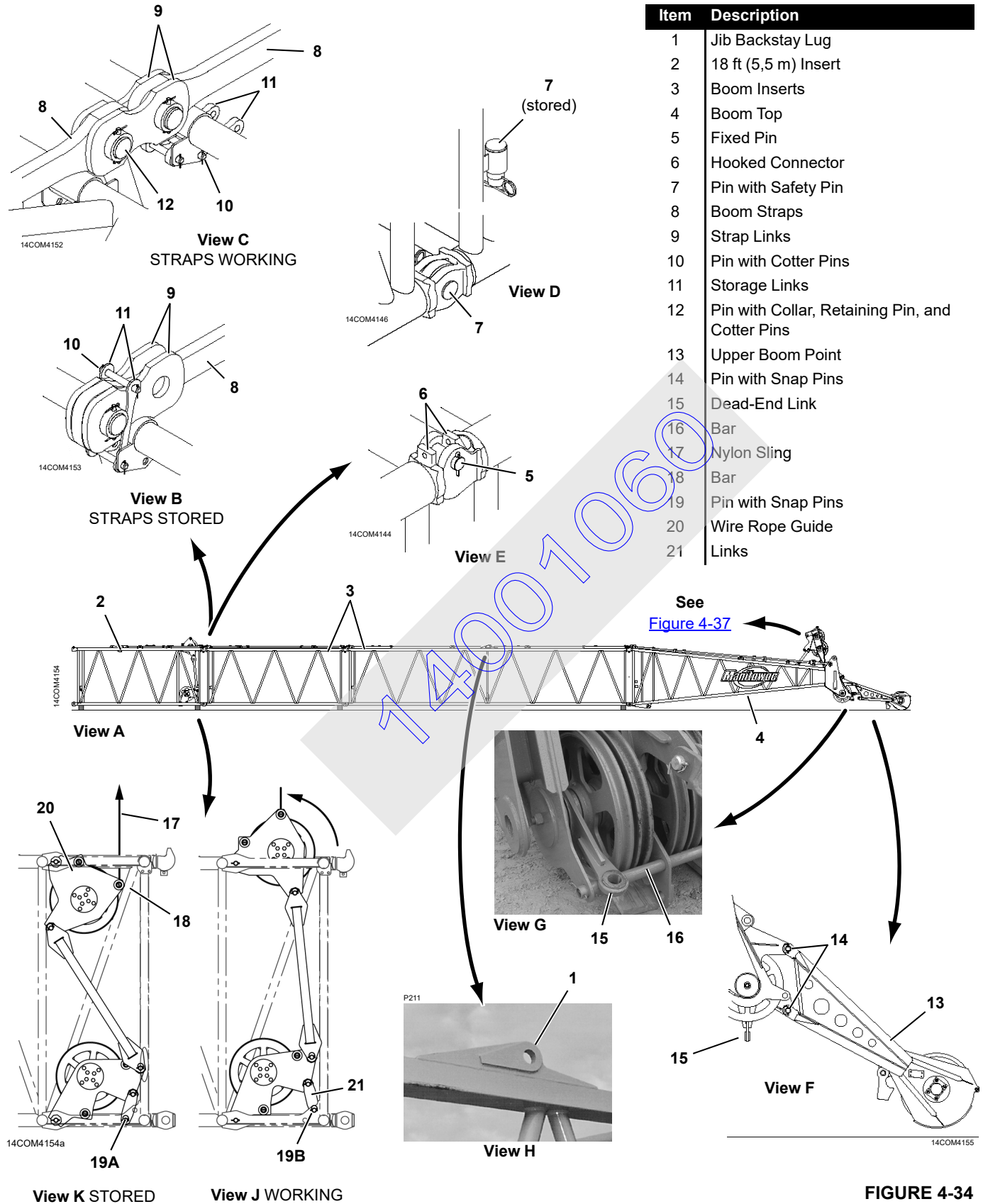


FIGURE 4-34

## Boom Installation – #76

See [Figure 4-34](#) for the following procedure.

### General

1. Before you start assembling boom, determine if a fixed jib will be installed. If so, install insert with backstay lugs (1, View H) next to boom top.
2. A minimum boom length of 105 ft (30,0 m) is required for fixed jib attachment (see Liftcrane Jib Capacity Chart for boom and jib length limitations).
3. Read all notes on Boom Assembly Drawing at end of this section.



### DANGER

#### Collapsing Boom Hazard!

To prevent death or serious injury, do not stand on, inside, or under boom sections during assembly. Always stand outside boom sections when installing connecting pins.

### Assemble Boom Sections

The boom sections have FACT™ connectors:

- Fixed pins in end of one section hook into top connectors at end of adjacent section (View E).
  - Bottom connectors are joined by removable pins (View D).
1. Assemble boom inserts in proper sequence as follows, starting at butt end of boom:

**NOTE:** See Boom Assembly Drawing at the end of this section to determine if intermediate suspension is required for your boom length. If required, be sure to install intermediate suspension strut at end of specified insert — see Boom Make-Up in Boom Assembly Drawing.

Also see Install Intermediate Suspension topic on [Page 77](#).

- a. Place 18 ft (5,5 m) insert (2, View A) on blocking at least 8 in (203 mm) high.
  - b. Lift next insert into position and engage fixed pins (5, View E) with hooked connectors (6).
  - c. Lower insert until bottom connector holes are aligned and install pins (7, View D). Pins are stored in pockets on adjacent insert.
  - d. Block under bottom chords at top end of insert.
2. Repeat steps [1b-1d](#) until all inserts are installed.
  3. Raise boom top wire rope guide. See procedure on [Page 4-78](#).

**NOTE:** Raise boom top wire rope guide before attaching lifting slings to boom top (see [Figure 4-33](#)).

4. Position dead-end link (15, View G) on top of bar (16) **to prevent damage to link when top is installed.**
5. Install boom top in same manner inserts were installed.

### Raise Auxiliary Drum Wire Rope Guide

See [Figure 4-34](#) for the following procedure.

Perform this procedure only if wire rope guide will be used.

1. Attach a nylon sling (17, View K) to bar (18) in upper wire rope guide.
2. Hoist just enough with crane so pin (19, View K) is loose.
3. Remove pin (19) from holes (A).
4. Slowly hoist to rotate wire rope guide (20) to working position (View J).
5. Pin links (21, View B) to holes (B)

### Install Upper Boom Point

See [Figure 4-34](#) for the following procedure.

1. Using nylon lifting slings, lift upper boom point (13, View F) into position at lower boom point.
2. Remove top pins (14) from holes in upper boom point.
3. Align top holes and install pins (14).
4. Rest upper boom point on ground.
5. Remove slings.
6. Install bottom pins (14) after boom and lower boom point are raised.

**NOTE:** Upper boom point must be removed for jib installation.

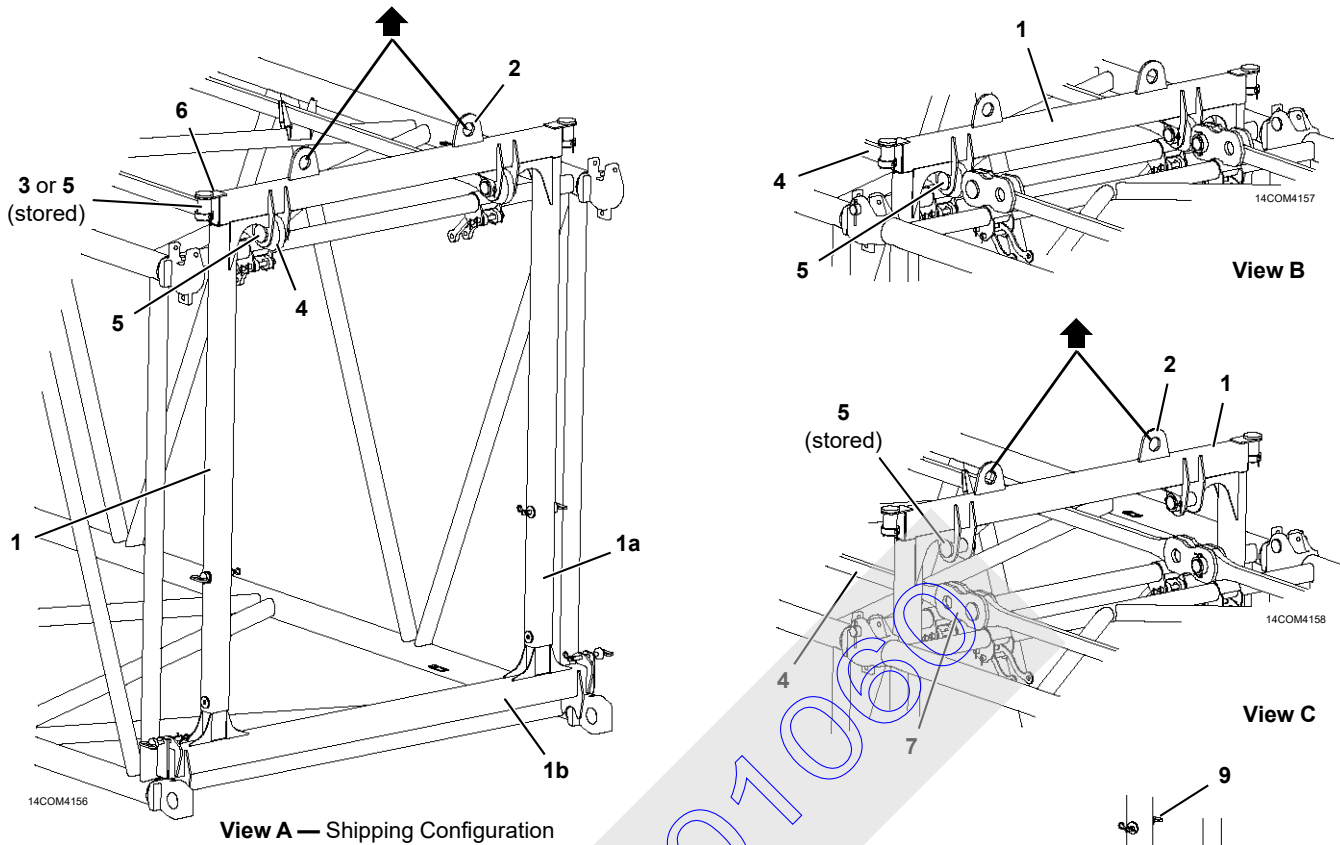
### Connect Boom Straps

See [Figure 4-34](#) for the following procedure.

The boom straps and links are shipped on the boom sections as shown in View B.

1. Connect straps (8, View B) at top end of each insert, as follows:
  - a. Remove pins (10, View B) and rotate links (11) to working position (View C).
  - b. Pin links (11, View C) in working position.
  - c. Remove pin (12, View C) from end of each strap (8).
  - d. Rotate links (9, View B) rearward and pin to adjacent strap (8) with pin (12, View C).

**NOTE:** If intermediate suspension is required see Install Intermediate Suspension topic on [Page 77](#).



View A — Shipping Configuration

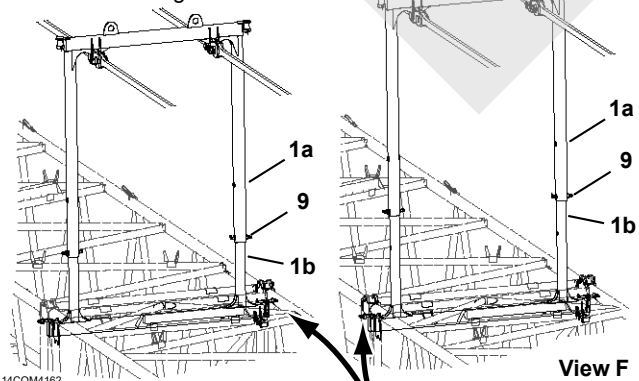
View B

View C

Legend is on [Page 77](#)

**Position A**  
223.1 - 262.5 ft (68 - 80 m)  
Boom Length

**Position B**  
272.3 - 292.0 ft (83 - 89 m)  
Boom Length

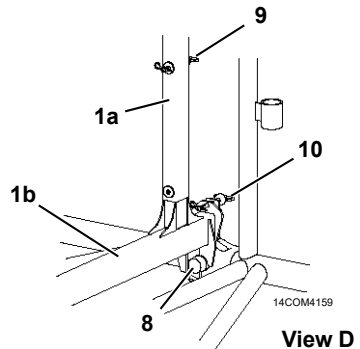


**Position A** = Pins (9) in lower holes of upper strut (1a) and lower holes of lower strut (1b)

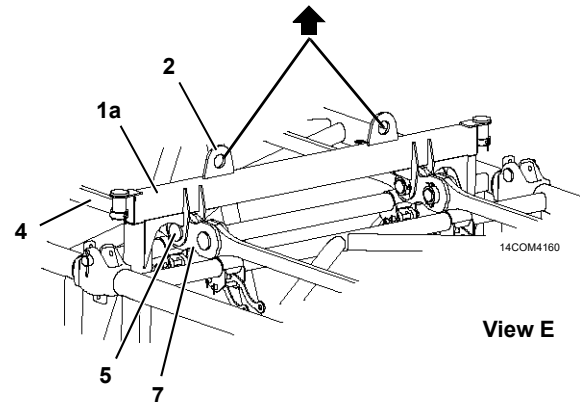
**Position B** = Pins (9) in lower holes of upper strut (1a) and upper holes of lower strut (1b)

View F

View G



View D



View E

FIGURE 4-35

**Install Intermediate Suspension**

See [Figure 4-35](#) for the following procedure.

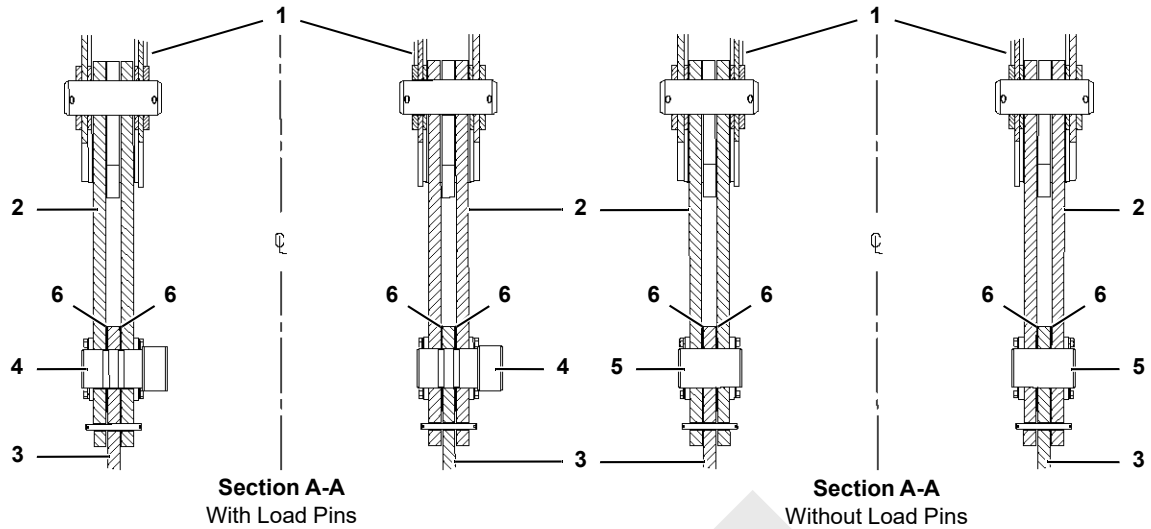
1. See View A for this step:
  - a. Connect lifting slings from assist crane to lifting lugs (2) on strut assembly (1).
  - b. Lift strut assembly (1) into position at end of proper insert.
  - c. Remove standard strap pins (3) from ends of straps (4).
  - d. Remove intermediate suspension strap pins (5) from storage lugs (6).
  - e. Pin strut assembly (1) to straps (4) with strap pins (5).
  - f. Store standard strap pins (3) in storage lugs (6).
2. Disconnect lifting slings and proceed to install remaining boom sections. Strut assembly (1, View B) will remain between boom sections.
3. See View C for this step:
  - a. Support strut assembly (1) with lifting slings attached to lifting lugs (2).
  - b. Remove intermediate strap pins (5) from ends of straps (4).
4. See View D for this step:
  - a. Lower strut assembly until it rests on bottom pins (8, View D) between boom sections.
  - b. Remove pins (9 and 10) from shipping position.
5. See View E for this step:
  - a. Raise upper strut (1a) as necessary to align strut with holes in straps (4) and strap links (7).
  - b. Reinstall strap pins (5).
  - c. Disconnect assist crane.
6. See View F for this step:
  - a. Slowly boom up to raise upper strut (1a).
  - b. Stop when upper strut is at proper position and install pins (9).
7. See View G for this step:
  - a. Continue to slowly boom up to raise strut assembly (1) to working position.
  - b. Stop when holes in lower strut (1b) are aligned with lugs on bottom of connectors (11).
  - c. Install pins (10).

14001060

**Legend for [Figure 4-35](#)**

Item	Description	Item	Description
1	Strut Assembly	6	Storage Lug
1a	Upper Strut	7	Strap Links
1b	Lower Strut	8	Bottom Pins (between inserts)
2	Lifting Lug	9	Hitch Pin with Hair-Pin Cotter
3	Standard Strap Pin with Collar, Retaining Pin, and Cotter Pins	10	Hitch Pin with Hair-Pin Cotter
4	Strap	11	Connector
5	Intermediate Suspension Strap Pin with Collar, Retaining Pin, and Cotter Pins		





Item	Description
1	Boom Top
2	Links
3	Strap
4	Load Pin
5	Pin
6	Shim (4 each)
7	Keeper Plate with Cap Screws and Lock Washer

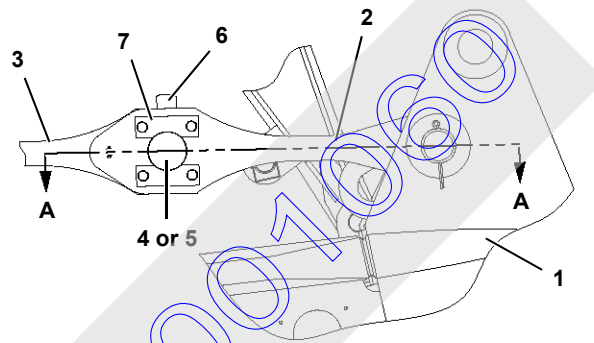


FIGURE 4-36

**Replace Load Pins for Duty-Cycle Operation**

If desired for duty-cycle operation only, load pins (4, [Figure 4-36](#)) in boom top (1) can be replaced with standard pins (5).

**NOTE:** If standard pins are used, the load pins in RCLI/RLI must be turned OFF in the operator’s cab to prevent error codes from being displayed (see Folio 2128, Manitowoc Model 14000 Rated Capacity Limiter (RCL) / Rated Capacity Indicator (RCI) Manual, for instructions).

**The load pins must be reinstalled for liftcrane operation. Whenever load pins are reinstalled, the pins must be recalibrated as instructed in Folio 2128, Manitowoc Model 14000 Rated Capacity Limiter (RCL) / Rated Capacity Indicator (RCI) Manual.**

To prevent side play of links (2) one shim (6) must be installed on each side of straps (3).

**Raise Boom Top Wire Rope Guide**

See [Figure 4-37](#) for the following procedure.

1. Attach lifting slings to wire rope guide (1 View A).
2. Hoist until slings are just tight and remove pins (2).
3. Raise wire rope guide to working position (View B).
4. Remove pins (3, View B) securing struts (4) in stored position.
5. Pin struts (4, View B) to boom top and store pins (3) in wire rope guide frame.

**Remove Lower Boom Point Sheaves**

Depending on boom length (and luffing jib length if installed) it may be necessary to remove lower boom point sheaves. See Liftcrane Capacity Chart or Luffing Jib Raising Procedure to determine boom and jib raising limitations. See Lower Boom Point Assembly topic on [Page 89](#) for sheave removal instructions.

**Install Jib**

If required, install jib. See Jib Installation topic on [Page 91](#) for instructions.

**Install Pile Driver Adapter**

If required, attach pile driver adapter. See Pile Driver Adapter topic on [Page 97](#).

**Install Clamshell Wire Rope Guide**

If required for clamshell operation, prepare the lower boom point as shown in [Figure 4-40](#).

**Connect Boom Butt to Boom**

Install boom butt, remove assembly block, connect boom butt to boom, and connect mast straps to boom straps. See Crane Assembly instructions starting on [Page 12](#).

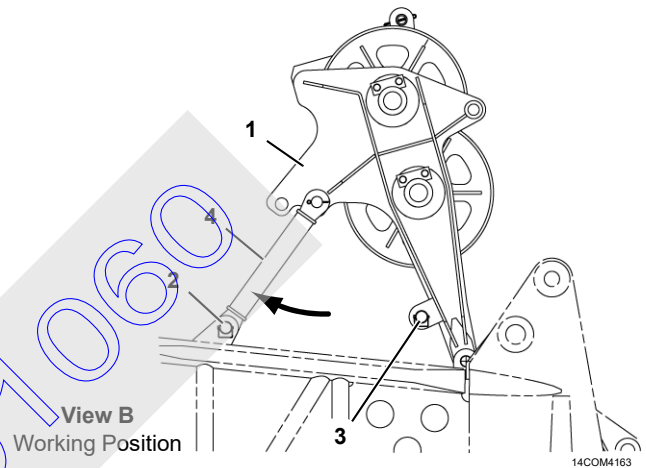
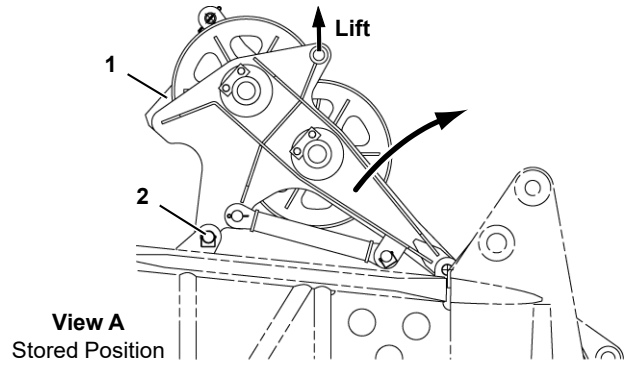
Make sure you perform the following steps. See Crane Assembly instructions starting on [Page 12](#).

1. Lower mast arms.
2. Select proper capacity chart on RCL display, Configuration screen.

**Install Load Line**

See Load Line Reeving instructions on [Page 107](#) for proper routing and reeving of load lines.

Remove bar (16, [Figure 4-34](#), View G) and lower dead-end link (15) to working position. Reinstall bar after load line is installed in lower boom point.



Item	Description
1	Wire Rope Guide
2	Pin with Snap Pins
3	Pin with Snap Pins
4	Strut

FIGURE 4-37

Item	Description	Item	Description
1	Wire Rope Guide	10	Upper Boom Point
2	Load Cell (RCL) or Pin	11	Weight
3	Wind Speed Transmitter	12	Lift Block
4	Lower Boom Point	13	Weight Ball
5	Block-Up Limit Switch	14	Shackle
6	Chain	15	Pin
7	Weight	16	Boom Node
8	Lift Block	17	Lug (weight storage)
9	Load Block		

Location of Components at Boom Top Shown  
Location of Components at Jib Top is Similar

See Load Block Reeving Diagrams for  
Suggested Location of Weight with  
Multiple Part Reeving

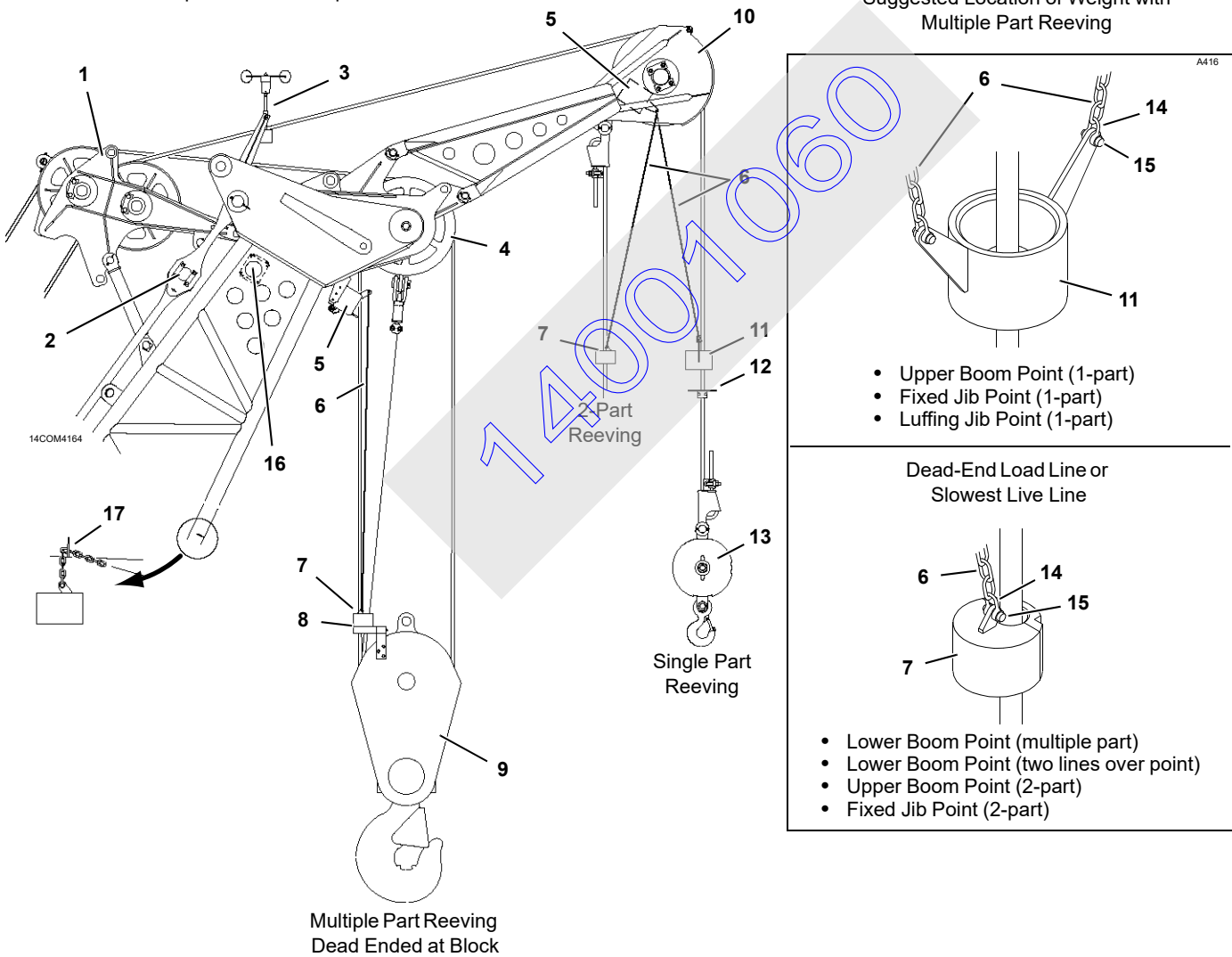


FIGURE 4-38

### Install Block-Up Limit Control and Connect Boom Wiring

Install block-up limit components as shown in [Figure 4-38](#) and in Boom Wiring and Limits Electrical Drawing at end of this section.

Connect plugs from electric cables to corresponding receptacles (see [Figure 4-39](#)).

- To prevent dirt and moisture from entering electric components, connect dust caps (1) to all unused plugs, terminating plugs, and receptacles
- Connect terminating plugs (SP) to unused plugs. Failing to perform this step will cause a fault alert and corresponding function will not operate properly
- Install wind speed indicator assembly if removed for shipping. Use star washers to attach mounting bracket to boom top to provide a good ground (see Wind Speed Assembly drawing at end of this section)
- Connect electrical cable at base of wind speed mounting bracket

14001060

Legend is on [Page 83](#)

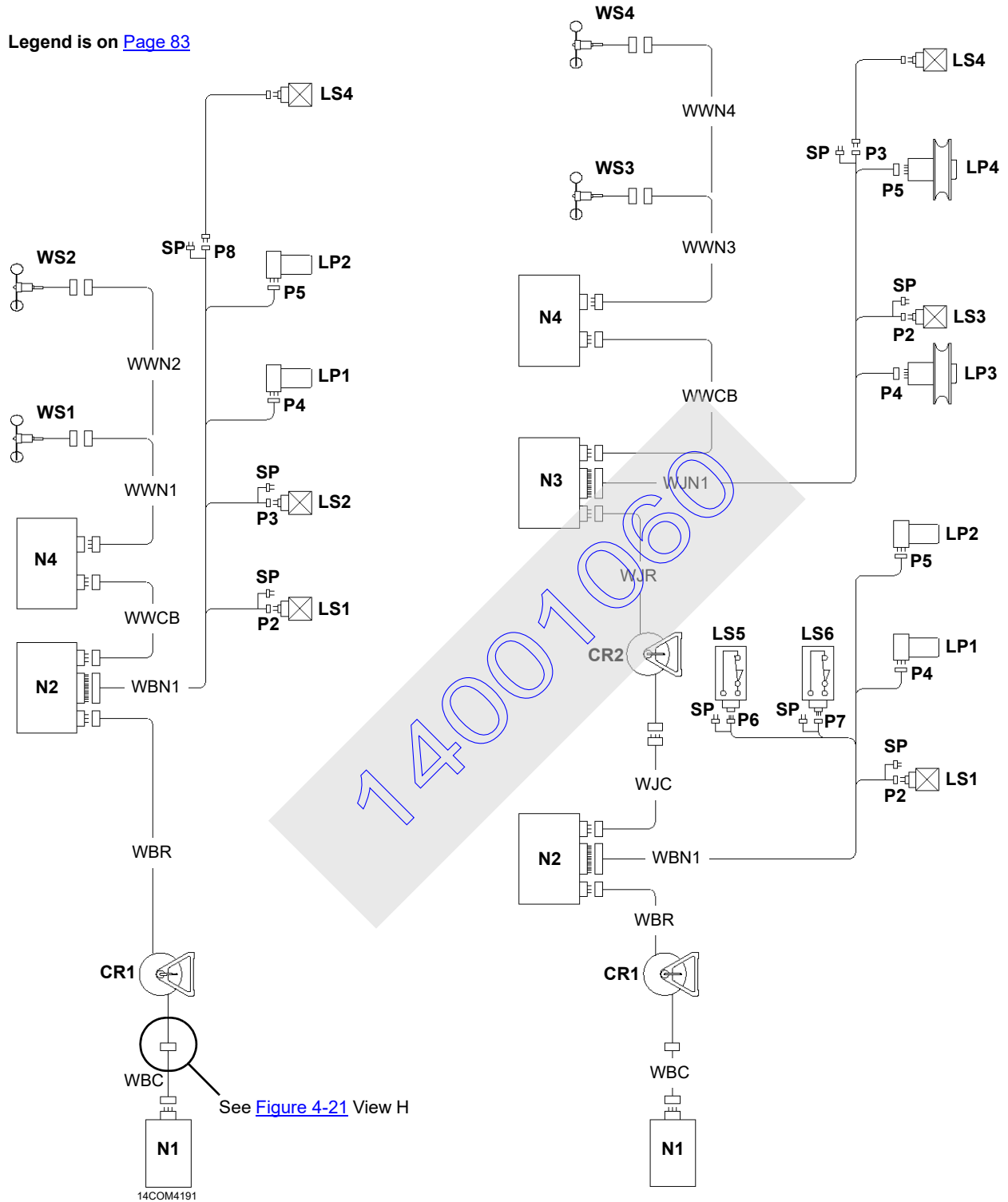
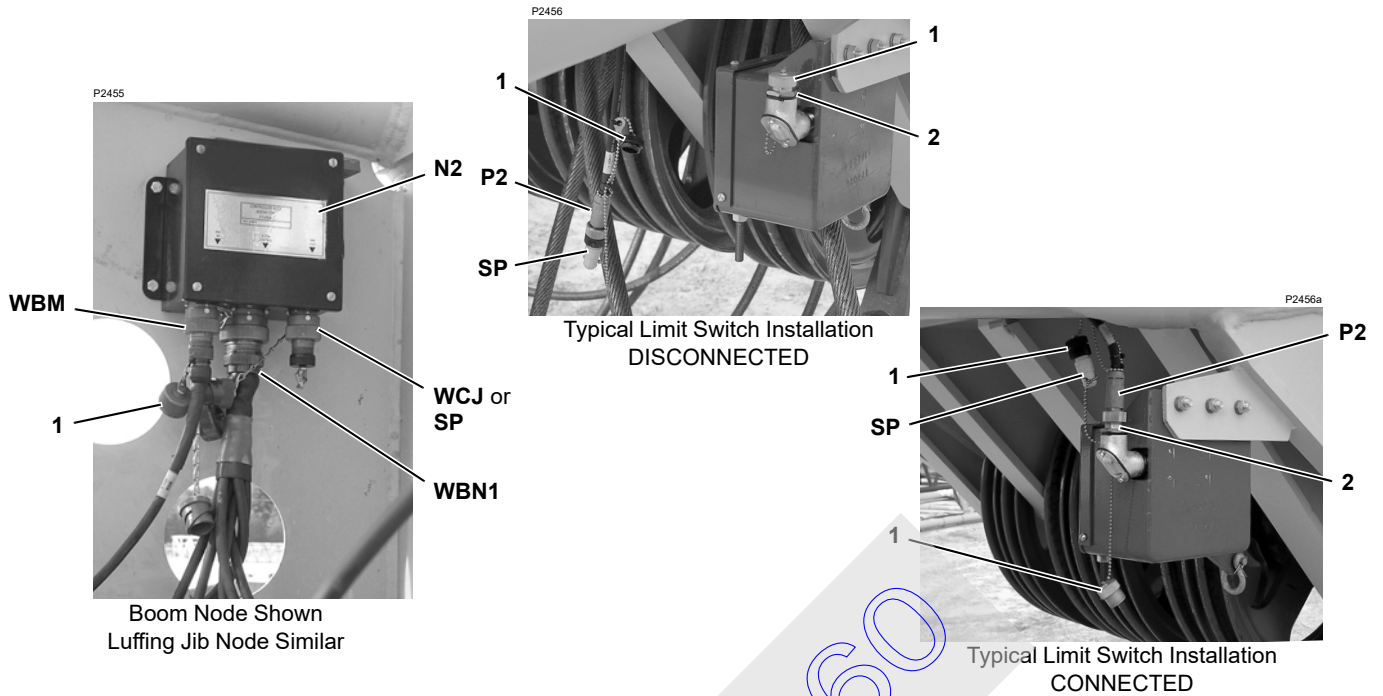


FIGURE 4-39



Item	Description	Item	Description
<b>CABLE ENDS</b>			
1	Dust Cap	LS3	Block-Up, Luffing Jib Point
2	Receptacle	LS4	Block-Up, Fixed Jib Point
<b>CABLES</b>			
WBC	From Engine Node	LS5	Max Up, Luffing Jib
WBR	From Boom Butt Cable Reel	LS6	Max Down, Luffing Jib
WBN1	To Boom Top	<b>LOAD PINS</b>	
WCJ	To Luffing Jib Butt Cable Reel	LP1	Boom Point, Left Side
WJR	From Luffing Jib Top Node	LP2	Boom Point, Right Side
WJN1	To Luffing Jib Top	LP3	Luffing Jib Point (sheave)
WWCB	To Wind Speed Node	LP4	Fixed Jib Point (sheave)
WWN1, 2, 3, or 4	To Wind Speed Indicator	<b>PLUGS</b>	
<b>CABLE REELS</b>			
CR1	Boom Butt	P2	Block-Up Limit Switch, Lower Boom Point OR Block-Up Limit Switch, Lower Luffing Jib Point
CR2	Luffing Jib Butt	P3	Block-Up Limit Switch, Upper Boom Point OR Block-Up Limit Switch, Fixed Jib Point
<b>NODES</b>			
N1	Engine	P4	Load Sensing Pin, Boom Left Side OR Load Sensing Sheave, Luffing Jib Point
N2	Boom	P5	Load Sensing Pin, Boom Right Side OR Load Sensing Sheave, Fixed Jib Point
N3	Jib	P6	Max Up Switch, Luffing Jib
N4	Wind Speed	P7	Max Down Switch, Luffing Jib
<b>LIMIT SWITCHES</b>			
LS1	Block-Up, Lower Boom Point	P8	Block-Up Limit Switch, Fixed Jib Point
LS2	Block-Up, Upper Boom Point	SP	Terminating Plug
<b>WIND SPEED TRANSMITTERS</b>			
WS1	Boom Top	WS1	Boom Top
WS2	Fixed Jib Top	WS2	Fixed Jib Top
WS3	Luffing Jib Top	WS3	Luffing Jib Top
WS4	Fixed Jib Top	WS4	Fixed Jib Top

FIGURE 4-39 continued

**THIS PAGE INTENTIONALLY LEFT BLANK**

14001060



## Boom Removal

### Lower Boom and Jib to Ground

See Crane Disassembly instructions starting on [Page 44](#).

### Store Load Lines

Disconnect load lines from load block and from hook-and-weight balls.

Spool load lines onto load drums for storage.

### Remove Block-Up Limit Control and Disconnect Boom Wiring

Remove and store block-up limit components ([Figure 4-38](#)) and disconnect electric cables:

- Disconnect electric cable from crane with boom butt controller
- Disconnect required electric cables in boom and jib. Connect terminating plugs where necessary ([Figure 4-39](#))
- Remove and store all wind speed indicator assemblies so they are not damaged during shipping

### Disconnect Boom Butt From Boom

Disconnect boom butt from boom, remove boom butt, and install assembly block. See Crane Disassembly instructions starting on [Page 44](#).

### Disassemble Boom Sections



## DANGER

### Collapsing Boom Hazard!

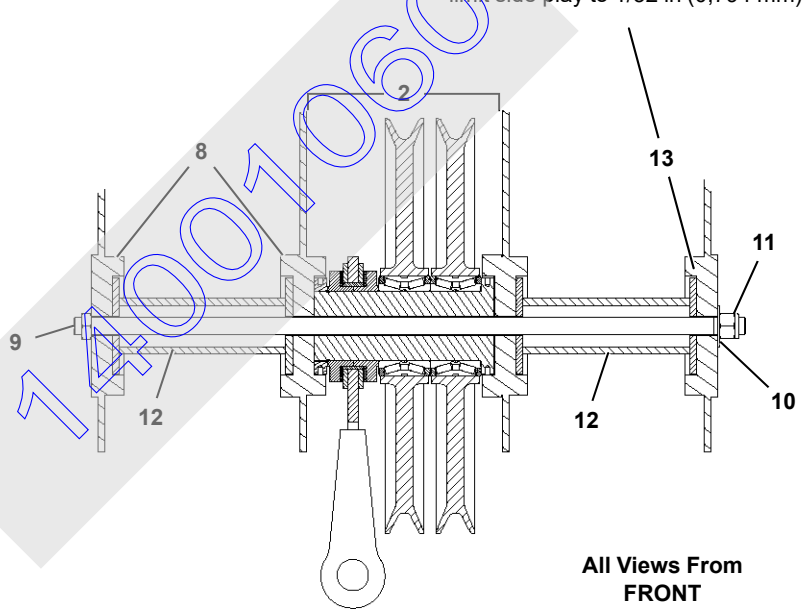
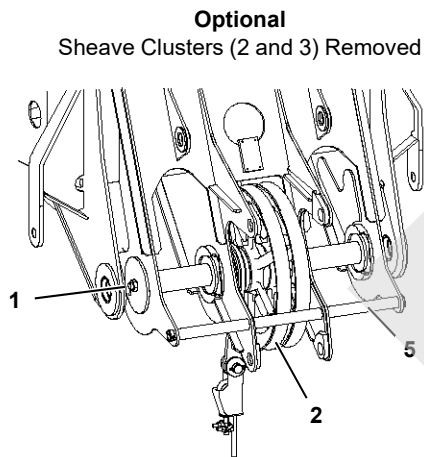
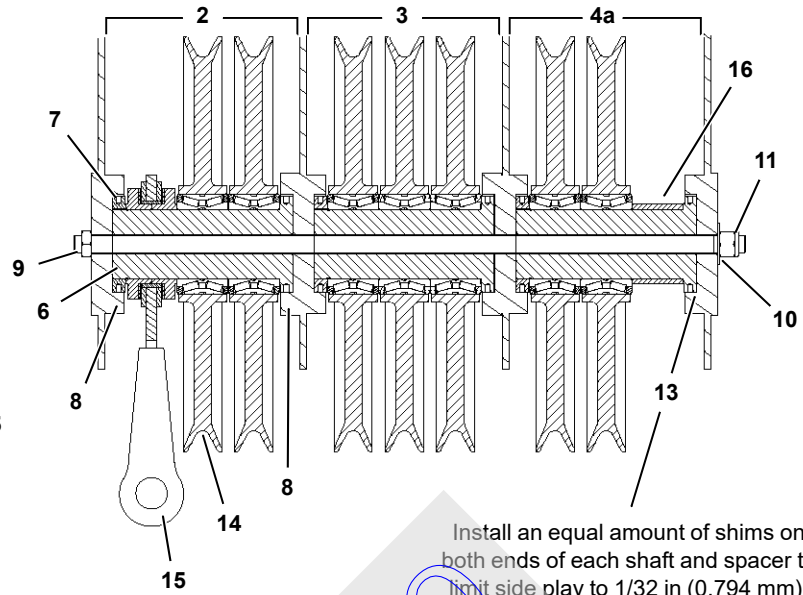
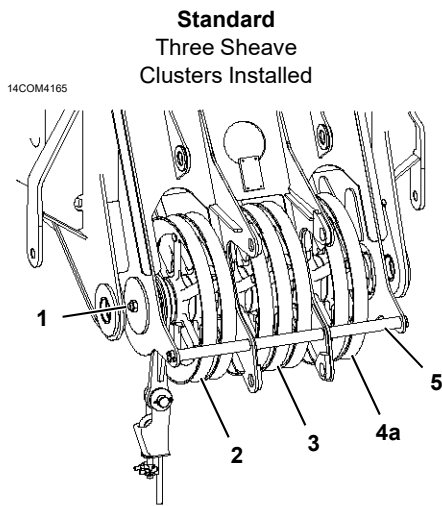
To prevent death or serious injury, do not stand on, inside, or under boom sections during boom disassembly. Always stand outside boom sections when removing connecting pins.

Disassembly of boom sections is the reverse of assembly.

1. If equipped with intermediate suspension, proceed as follows:

See [Figure 4-35](#) for steps [1a](#) through [1l](#).

- a. Connect slings from assist crane to lifting lugs (2, View E) on upper strut (1a).
  - b. Lift upper strut (1a) as necessary to loosen strap pins (5).
  - c. Remove strap pins (5).
  - d. Raise strut assembly (1) high enough to allow strap links (7) to be rotated into stored position (View C).
  - e. Lower strut assembly (1) to align strut with holes in straps (4) and reinstall pins (5, View B).
  - f. Remove boom sections up to intermediate strut assembly (1, View A).
  - g. Connect lifting slings from assist crane to lifting lugs (2) on strut assembly (1).
  - h. Remove pins (3) from storage lugs (6, View A) in ends of strut assembly (1).
  - i. Hoist with assist crane as required so strap pins (5) are loose.
  - j. Remove strap pins (5) and store them in storage lugs (6, View A) in ends of strut assembly (1).
  - k. Lift strut assembly away from boom.
  - l. Install pins (3) in ends of straps (4).
2. Store boom top wire rope guide as shown in View A, [Figure 4-37](#).
  3. If used, store auxiliary drum wire rope guide (20) as shown in View K, [Figure 4-34](#).
  4. Store boom straps and links as shown in View B, [Figure 4-34](#).
  5. Remove wind speed indicator from boom/jib top to prevent damage during shipping (see Wind Speed Assembly drawing at end of this section).
    - a. Disconnect electrical cable from the wind speed indicator at base of mounting bracket.
    - b. Remove nuts, star washers, and bolts from base of wind speed mounting bracket.
    - c. Store wind speed assembly in a safe place on crane.



Item	Description	Item	Description
1	Lower Boom Point	10	Flat Washer (2 each)
2	Sheave Cluster with Dead-End Link	11	Elastic Stop Nut
3	Sheave Cluster with 3 Sheaves	12	Spacer
4a	Sheave Cluster with 2 Sheaves	13a	Shims 22 gage (0,029 mm)
4b	Sheave Cluster with 2 Sheaves	13b	Shims 16 gage (0,059 mm)
5	Rope Guard	14	Sheave
6	Shaft	15	Dead-End Link
7	Spanner Nut	16	Spacer
8	Saddle	17	Rope Guard (clamshell)
9	Bolt		

FIGURE 4-40

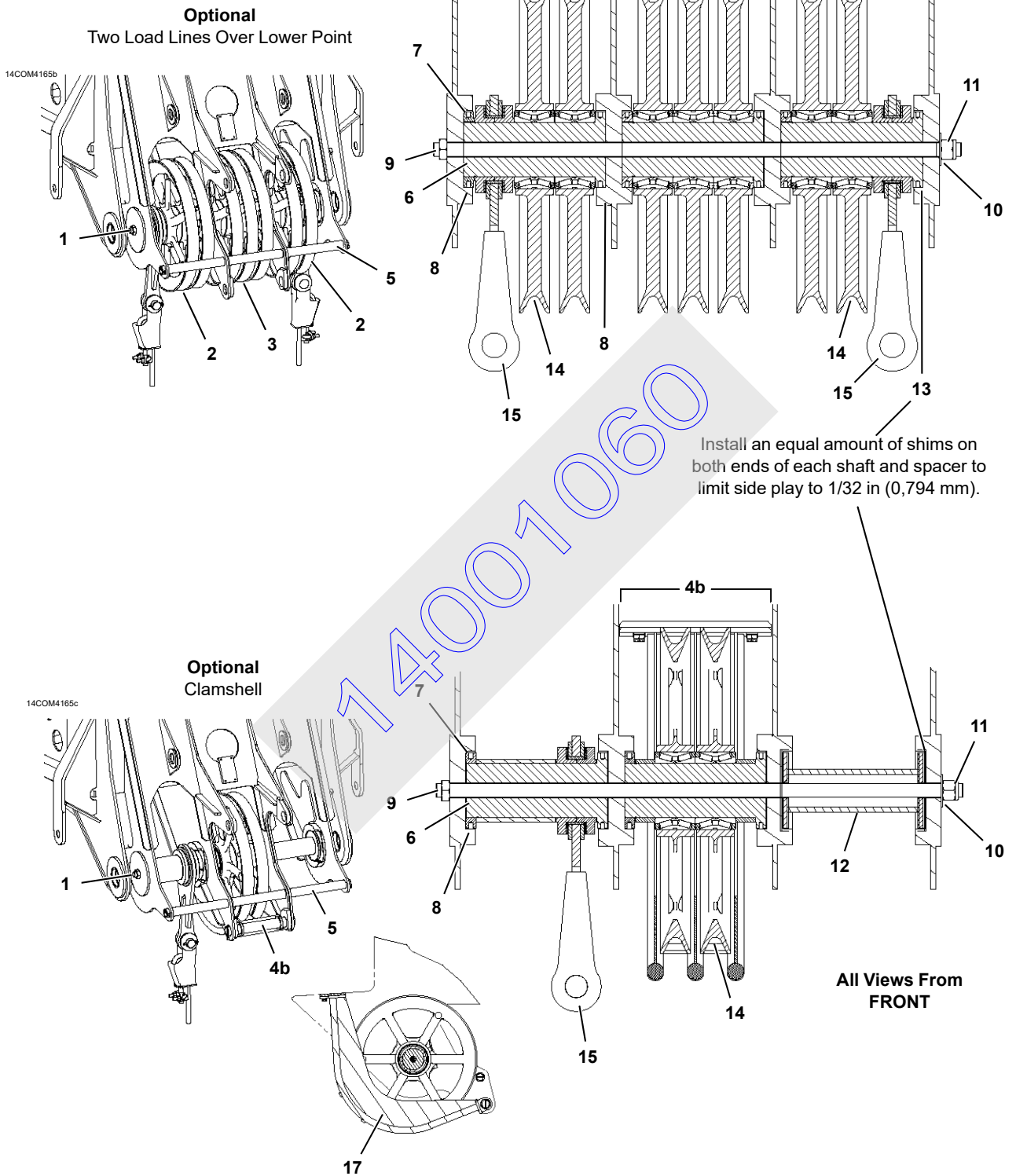


FIGURE4-40continued

**THIS PAGE INTENTIONALLY LEFT BLANK**

14001060

## Lower Boom Point Assembly

See [Figure 4-40](#) for the following procedures.

### General

Standard lower boom point (1) is equipped with seven sheaves in three clusters (2, 3, and 4).

Each sheave cluster is retained on a separate shaft (6) with a spanner nut (7). The sheave clusters are supported by saddles (8) in the boom top and retained with bolt (9) and elastic stop nut (11).

Sheave clusters (3 and 4) must be removed before the crane can be operated with some boom lengths or some boom and luffing jib lengths. See Capacity Chart or Luffing Jib Raising Procedure Chart to determine which boom lengths require removal of the sheave clusters.

Sheave cluster (3) weighs 460 lb (209 kg). It is the heaviest load.



### WARNING

#### Tipping Crane Hazard!

Do not attempt to raise boom until sheave clusters (3 and 4) have been removed for boom lengths specified in Capacity Chart or Luffing Jib Raising Procedure Chart. Crane will tip if this step is not performed.

**NOTE:** For luffing jib operation with the lower boom point removed, bolt (9, [Figure 4-40](#)) and all spacers (12) must also be removed.

### Removing and Installing Sheave Clusters

If the following occur, perform the following steps:

- When it is necessary to move the dead-end link, or
- Prior to lengthening the boom to a length that requires sheave clusters (3 and 4) be removed

1. Lower boom so that sheaves touch ground or blocking.

**NOTE:** Centerline of saddles (8) are tilted 15° upwards when boom is horizontal to ground.

2. Remove rope guard (5).
3. Remove elastic stop nut (11), washer (10) and bolt (9).

4. If sheave clusters (3 and 4) are being removed, proceed as follows:

- a. Pull sheave clusters out of lower boom point.
- b. Store sheave clusters (3 and 4). Sheave cluster (2) must be installed in middle of lower boom point.
- c. Install a spacer (12) on both sides of lower boom point.
- d. Install an equal thickness of shims (13) on both ends of both spacers (12) to limit side play to 1/32 in (0,794 mm).

5. Install required number of sheave clusters in saddles in lower boom point.

If only one cluster is used, install sheave cluster (2) in middle of lower boom point.

If all three sheave clusters are used, install sheave cluster with dead-end link in proper position as shown in Load Line Reeving instructions on [Page 107](#).

6. Install an equal thickness of shims (13) on both ends of each sheave cluster (2, 3, and 4) to limit side play to 1/32 in (0,794 mm).
7. Install bolt (9) with flat washers (10) and securely tighten elastic stop nut (11).
8. Install rope guard (5).

### Greasing Sheave Bearings

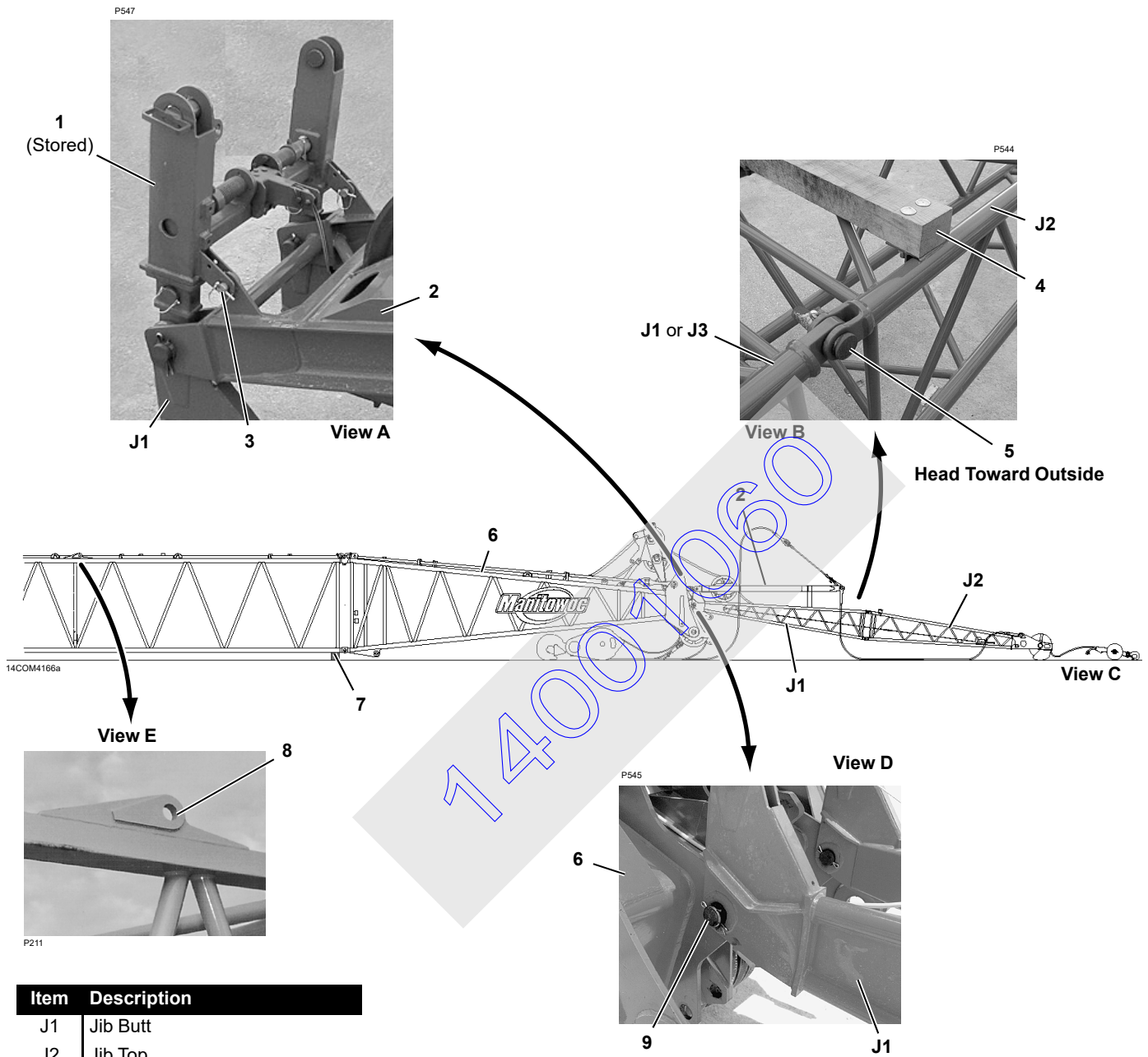
Carefully hand pack each sheave bearing with MOBILUX EP #2 grease when a sheave assembly is overhauled.

Be sure to also fill cavities between bearing and seals with grease.

### Adjusting Bearing Side Play

Perform the following steps when assembling a sheave cluster:

1. Assemble required number of sheaves (14), dead-end link (15), and spacer (16) on shaft (8).
2. Clean threads of shaft (6) and spanner nut (7) with solvent.
3. Apply LOCTITE #243 or equivalent thread locking adhesive to threads of shaft.
4. Install spanner nut (7) and tighten to approximately 75 ft-lb (102 Nm) to remove all bearing side play.



**Item Description**

- J1 Jib Butt
- J2 Jib Top
- J3 Jib Insert
- 1 Jib Stop
- 2 Strut
- 3 Pin with Snap Pins
- 4 Wire Rope Timber Guards
- 5 Pin with Cotter Pin
- 6 Boom Top
- 7 Blocking
- 8 Backstay Lug
- 9 Pin with Cotter Pins

FIGURE 4-41

## Jib Installation – #134

### General

See Jib Assembly Drawing at the end of this section for jib makeup.

The jib assembly may be shipped from Manitowoc as shown in [Figure 4-42](#).

Jib offsets (5°, 15°, 25°) are set by changing the lengths of the jib backstay straps, links, and pendants (View A, [Figure 4-43](#)).

See [Figure 4-41](#) for the following procedures.

### Prepare Boom

1. Lower boom onto blocking (7, View C).
2. Remove load line from upper boom point, if equipped.
3. Remove and store upper boom point.
4. Make sure insert with jib backstay lugs (8, View E) is installed next to boom top (6).

### Install Butt

1. Lift jib butt (J1, View D) into position and align holes in jib butt with holes in boom top.
2. Install pins (9, View D).

### Install Inserts



### WARNING!

#### Collapsing Jib Hazard!

To prevent death or serious injury, do not stand on, inside, or under jib during assembly. Always stand outside of jib when installing connecting pins.

1. Pin desired length of jib inserts (J3) to jib butt (J1):
  - Wire rope timber guards (4, View B) must face up
  - Shortest inserts must be closest to butt
  - Pin (5) heads must be toward outside of jib (View B)
2. Block inserts as assembly progresses.

### Install Top

Pin jib top (J2) to last insert (J3) or to jib butt (J1), depending on jib length:

- Pendant lugs on jib top must face up
  - Pin (5) heads must be toward outside of jib (View B)
- If not already done, install wire rope timber guard (4, View B)

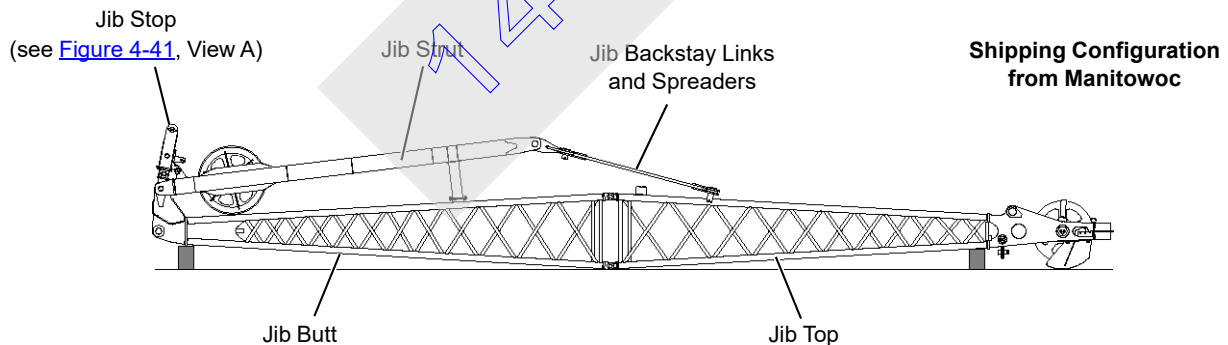
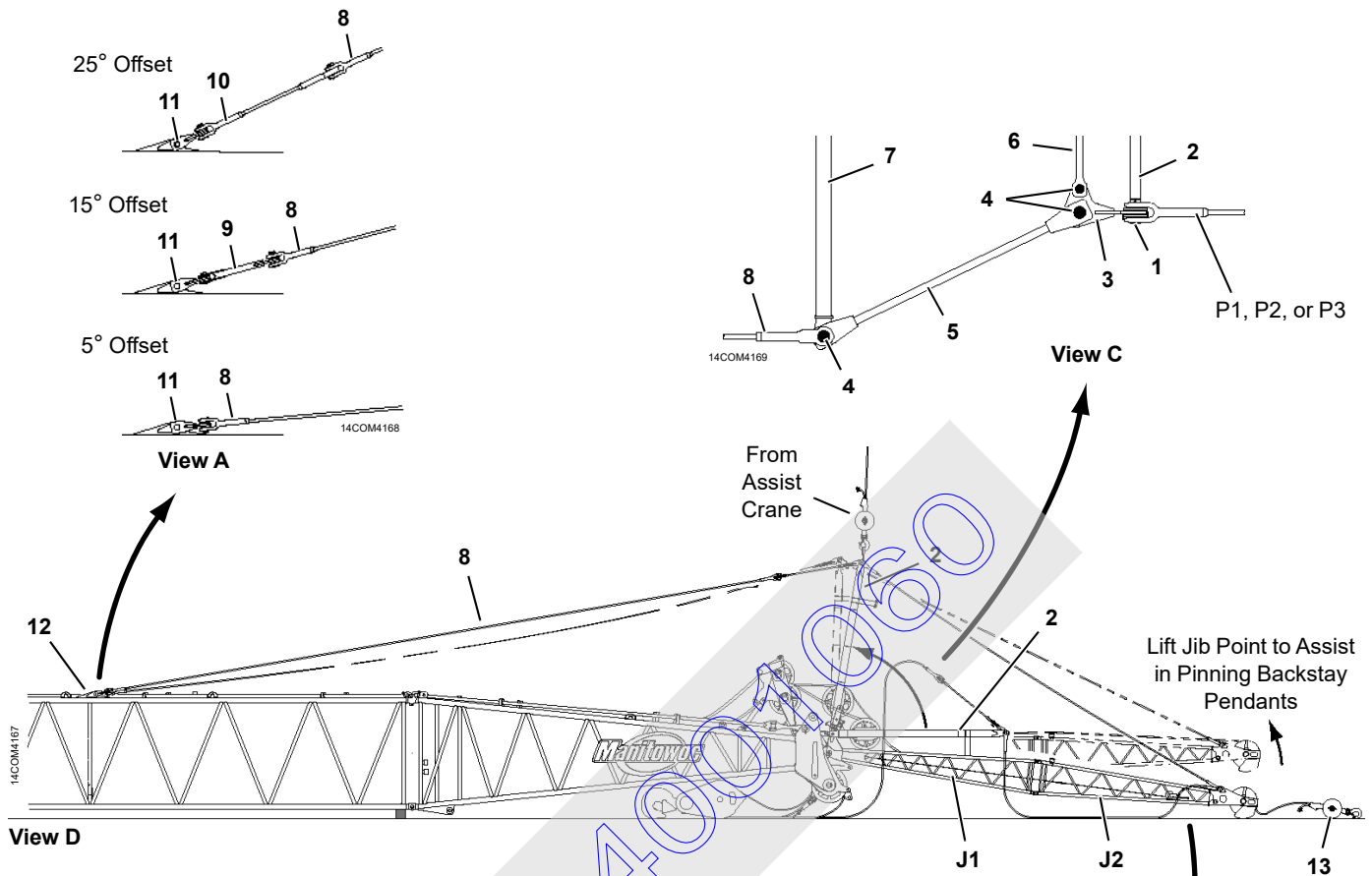


FIGURE 4-42





Item	Description
J1	Jib Butt
J2	Jib Top
P1	Basic Jib Pendant — 30 ft 9 in (9,37 m)
P2	Jib Pendant — 19 ft 0 in (5,79 m)
P3	Jib Pendant — 9 ft 6 in (2,89 m)
1	Pin with Cotter Pin
2	Jib Strut
3	Strut Link
4	Pin with Cotter Pin
5	Backstay Link
6	Upper Spreader
7	Lower Spreader
8	Backstay Pendant with Pin — 44 ft 7 in (13,6 m)
9	15° Offset Link with Pin — 28 in (711 mm)
10	25° Offset Pendant with Pin — 4 ft 8 in (1,4 m)
11	Backstay Link with Pin
12	Backstay Lug
13	Weight Ball

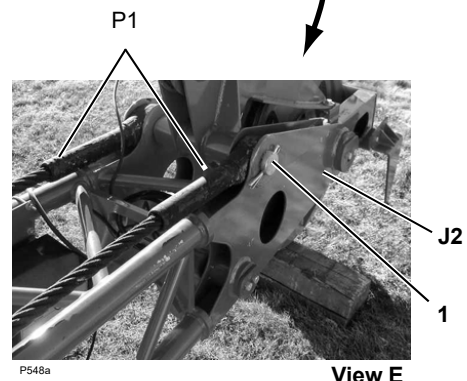


FIGURE 4-43

See [Figure 4-43](#) for the following procedures.

### Install Jib Pendants

**NOTE:** With the exception of the basic pendants, the jib pendants must be installed in the same sequence as the inserts.

The jib pendants (and backstay pendants) are furnished in matched sets of two and must be installed in matched sets — pendant on one side of insert must match pendant on other side of insert.

1. Pin basic jib pendants (P1) to lugs on jib top (J2, View E).
2. Lay pendants on the ground.
3. Assemble remaining jib pendants in proper sequence according to Jib Assembly Drawing. Shortest pendants must be closest to butt.
4. Pin pendants (P1, P2, or P3) to strut links (3) and to jib strut (2, View C).

### Install Backstay Pendants

See View C for the following procedure.

1. Install backstay links (5).
2. Pin backstay pendants (8) to backstay links (5) and lower spreader (7).

3. Install upper spreader (6) between strut links (3).
4. Lay backstay pendants (8) on ground alongside boom.

### Install Jib Offset Links or Pendants

See View A for the following procedure.

1. Pin backstay links (11) to backstay lugs (12).
2. Depending on jib offset, pin links (9) or pendants (10) to backstay links (11).

### Connect Jib Backstay Pendants

1. Using appropriate slings, attach hook from assist crane to front side of sheave in jib strut (2).
2. Slowly lift jib strut over center with assist crane. **Use extreme caution not to side load strut while lifting.**
3. If required, raise jib point with an outside assist (another crane or fork-lift truck) to gain enough slack to allow pinning backstay pendants.
4. Pin backstay pendants (8):
  - For **5° offset**, to backstay links (11)
  - For **15° offset**, to offset links (9)
  - For **25° offset**, to offset pendants (10)

140010680

Item	Description
1	Jib Stop Assembly
2	Jib Strut
3	Pin with Snap Pin
4	Boom Top
5	Pin with Cotter Pin
6	Offset Pin with Snap Pins
7	Inner Tube
8	Link
9	Control Cable Extension
10	Sheave
11	Control Cable (from jib stop)
12	Shackle
13	Control Cable (from winch)
14	Winch
15	Pawl Lever
16	Safety Pin
17	Jib Stop Pin

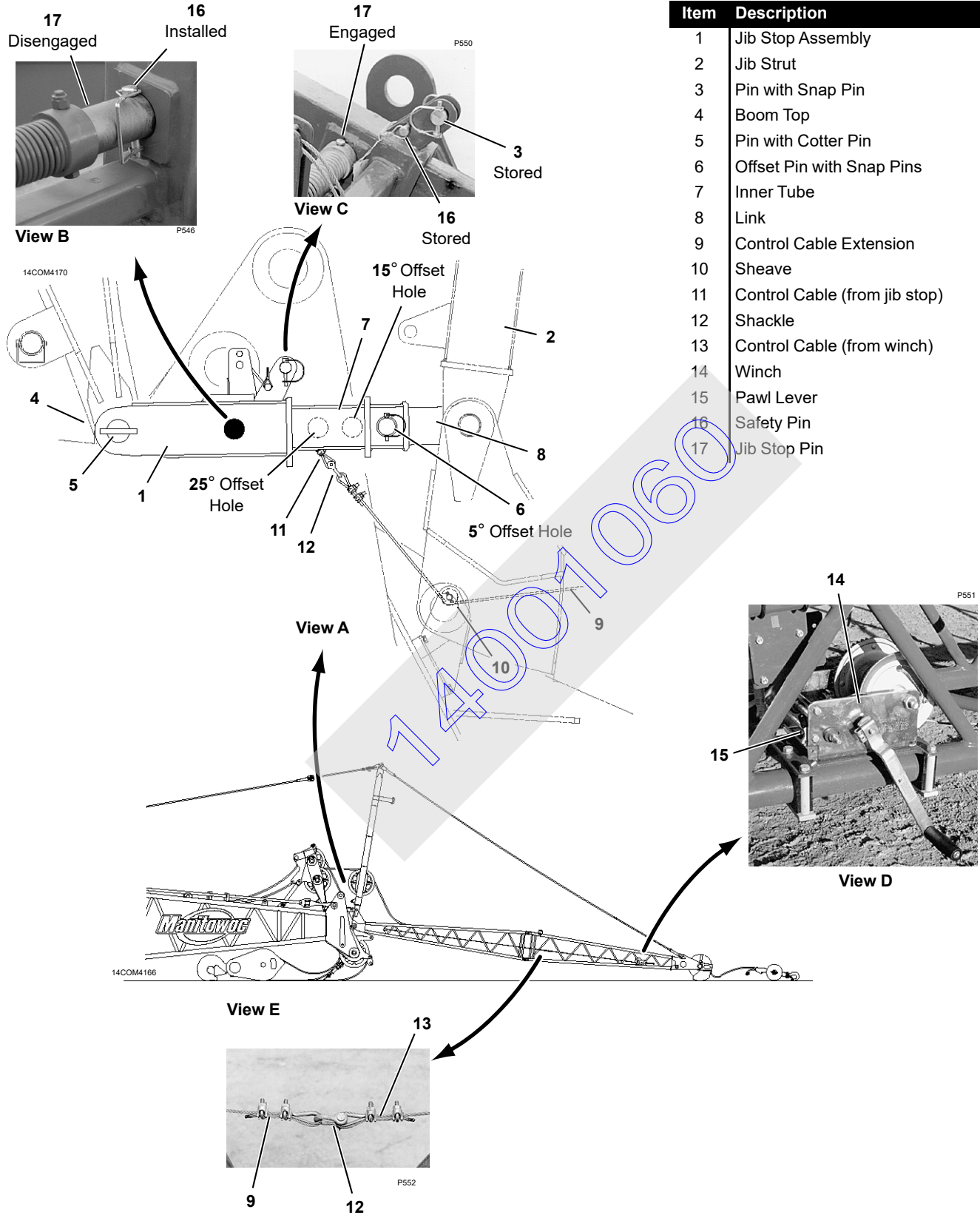


FIGURE 4-44

**Install Jib Stop**

**! WARNING**  
**Crushing Injury!**

Jib stop pins are spring engaged. Do not remove safety pins until jib stop assembly is pinned in working position and control cables are attached and tensioned.

1. Remove pins (3, View A, [Figure 4-41](#)), and lower jib stop assembly (1) to working position on boom top (4).

See [Figure 4-44](#) for the remaining steps.

2. Pin jib stop (1, View A) to lugs on boom top (4).
3. Store pins (3, View C).
4. Adjust jib stop length as follows (View A):
  - a. Remove offset pins (6).
  - b. Adjust position of inner tubes (7) so holes in tubes are aligned with proper offset holes in links (8).
  - c. Reinstall offset pins (6).
5. Connect jib stop control cable as follows:
  - a. Route cable extension (9, stored in jib butt) through sheave (10) in boom top (View A).
  - b. Connect end of cable extension (9) to jib stop control cable (11) with shackle (12, View A).
  - c. Connect other end of cable extension (9) to winch control cable (13) with shackle (12, View F).
6. Use winch (14) on jib top to take load off safety pins (16, View B) (loosen pins) and remove safety pins.
7. Pay out control cable to engage jib stop pins (17, View C). Then pay out an additional 2 ft (0,6 m) of control cable.
8. Store safety pins (16, View C).
9. Boom up until jib point just clears ground.

**! WARNING**  
**Falling Jib Hazard!**

Visually observe that jib stop pins fully engage holes in jib stop frame as boom and jib are raised from ground. Jib can be pulled over backwards if jib stop pins do not engage.

**Install Load Line**

See Load Line Reeving instructions on [Page 107](#) for proper routing and reeving of load lines.

Remove the rope guards ([Figure 4-45](#)) to pull the load line through the jib point and strut without removing the socket and wedge.

**Install Block-Up Limit Control and Connect Jib Wiring**

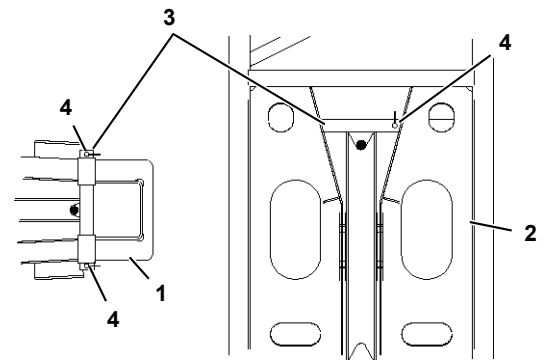
Install block-up limit components as shown in [Figure 4-38](#) and in Boom Wiring and Limits Electrical Drawing at end of this section.

Connect plugs from electric cables to corresponding receptacles (see [Figure 4-39](#)).

- To prevent dirt and moisture from entering electric components, connect dust caps (1) to all unused plugs, terminating plugs, and receptacles
- Connect terminating plugs (SP) to unused plugs. Failing to perform this step will cause a fault alert and corresponding function will not operate properly
- Install wind speed indicator assembly if removed for shipping. Use star washers to attach mounting bracket to jib top to provide a good ground (see Wind Speed Assembly drawing at end of this section)

Connect electrical cable at base of wind speed mounting bracket.

14COM4171



Item	Description
1	Jib Top
2	Jib Strut
3	Rope Guard
4	Safety Pin

**FIGURE 4-45**

## Jib Removal – #134



### DANGER

#### Collapsing Jib Hazard!

To prevent death or serious injury, do not stand on, inside, or under jib during disassembly. Always stand on outside of jib when removing connecting pins.

Support jib properly before removing pins. Block sections at connection points.



### WARNING

#### Crushing Injury!

Jib stop pins are spring engaged. Do not disconnect control cables until safety pins are installed.

### CAUTION

#### Jib Stop Damage!

Avoid jib stop damage. Do not allow jib point to contact ground until jib stop pins are disengaged.

### Lower Boom and Jib

1. Lower boom until jib point is approximately 12 in (305 mm) from contacting ground.

See [Figure 4-44](#) for the following steps.

2. Disengage jib stop pins (17, View B) by hauling in cable on winch (14, View E). Turn handle until cable is tight and engage pawl (15). **Visually check that pins are disengaged.**
3. Remove safety pins (16, View C) from storage and install them in jib stop pins (17, View B).
4. Lower boom onto blocking.
5. Remove weight ball or load block and wire rope from jib point.
6. Remove block-up limit parts from jib point and store.
7. Disconnect both ends of electric cable in jib and coil onto brackets on jib butt. Be sure to install terminating plug ([Figure 4-39](#)).
8. Remove and store all wind speed indicator assemblies so it is not damaged during shipping.

### Store Jib Stop

See [Figure 4-44](#) for the following procedure.

1. Store control cable:
  - a. Disconnect cable extension (9, View A and F) from shackles (12). Store shackles with cable extension.

- b. Disconnect cable extension (9, View A) from sheave (10) in boom top.
  - c. Secure cable extension in jib butt for storage.
  - d. Coil excess control cable (13, View F) onto winch.
2. Readjust length of jib stop by pinning it in 5° offset position (View A).
  3. Remove storage pins (3, View C) from storage.
  4. Raise jib stop assembly and pin to strut with storage pins (3, View A, [Figure 4-41](#)).

### Lower Strut

See [Figure 4-43](#) for the following procedure.



### WARNING!

#### Pendant Under Tension!

Do not disconnect pendants until pendants are slack.

1. Using appropriate slings, attach hook from assist crane to front side of sheave in jib strut (2, View D). Avoid lifting jib butt/boom top during this step.
2. If required, raise jib point with another crane or a fork-lift truck to gain enough slack to allow unpinning backstay pendants.
3. Disconnect backstay pendants (8, View A) from links (9 or 11) or from pendants (10).
4. Lay backstay pendants on the ground alongside boom.
5. Lower jib point to the ground.
6. Lower jib strut onto jib butt.
7. Disconnect crane from jib strut.
8. Remove and store links (9 or 11, View A) or pendants (10).

### Remove Backstay Pendants

See View C, [Figure 4-43](#) for the following procedure.

1. Disconnect and remove backstay pendants (8, View C) and spreader (7) from strut links (3).
2. Coil and store backstay pendants for future use.

### Remove Jib Pendants

See View C and E, [Figure 4-43](#) for the following procedure.

1. Disconnect pendants (P1, P2, P3) from jib strut (2) and from jib top (J2).
2. Disassemble and remove all jib pendants from jib.
3. Coil and store jib pendants for future use.

4. Store backstay spreader (6) and links (3).

**Remove Jib Sections**

Reverse installation steps to remove jib sections.

**Pile Driver Adapter Installation**

**Installation**

If required, install the optional pile driver adapter to the boom point as shown in [Figure 4-46](#).

**CAUTION**

Pile driver adapter must be used only with freely suspended loads.

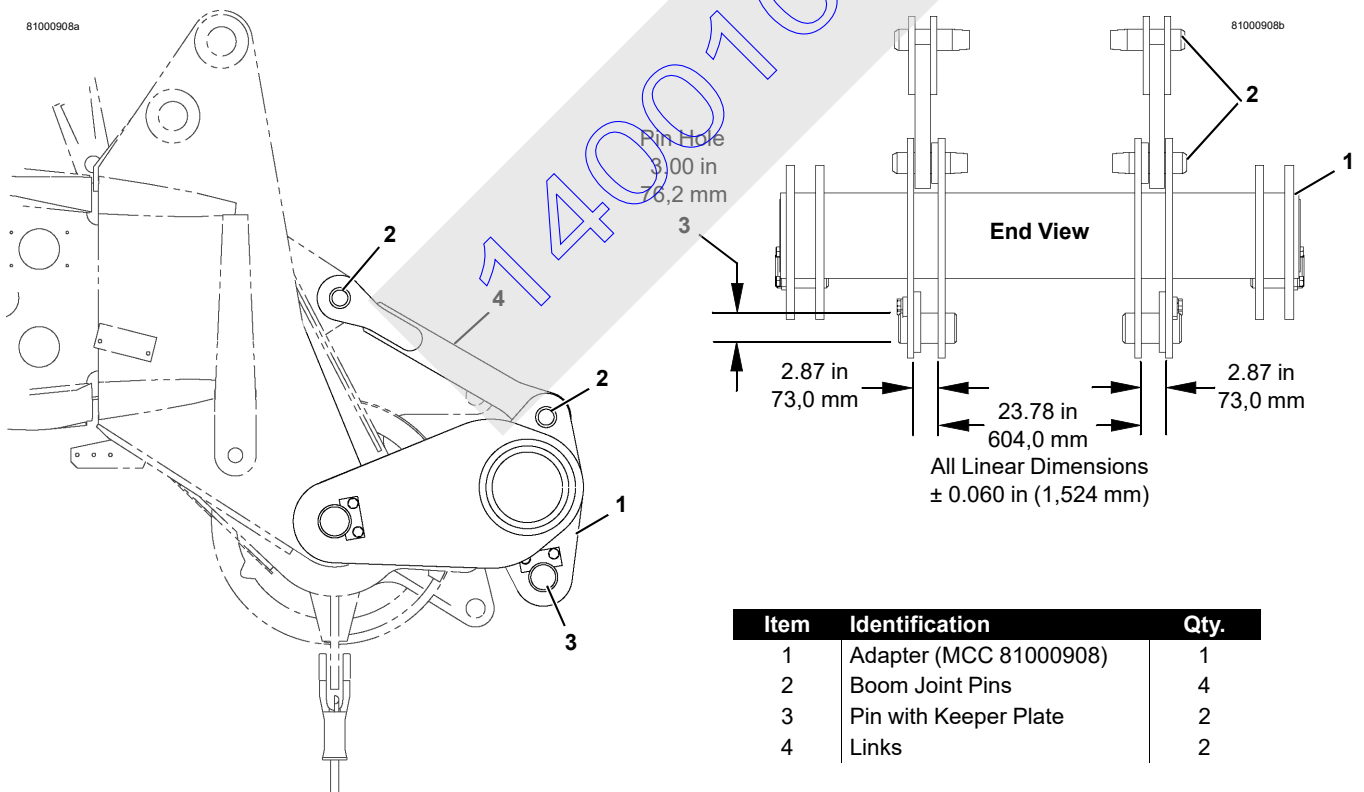
Any side load or torque generated by owner supplied attachments will reduce design loads given in this section. In such cases, contact your Manitowoc dealer for specifications which meet your particular application.

Values given in this publication apply to pile driver adapter only. In all cases, pile drive adapter loads cannot exceed those listed for main boom capacity.

**Operating Specifications With #76 Top**

See [Figure 4-46](#) for installation.

- Maximum Boom Length = 134.5 ft (42,7 m)
- Maximum Load Per Side = Design Load divided by 2
- Design Loads = 60,000 lb (2 7215,5 kg) at 65° Boom Angle and 48,000 lb (21772 kg) at 55° Boom Angle



**FIGURE 4-46**



## WIRE ROPE INSTALLATION

**NOTE:** Wire rope manufacturer’s recommendations take precedence over information in this section.

### Wire Rope Storage

Store wire rope in coils or on reels off the ground or floor in a clean and dry indoor location. If outdoor storage is necessary, the wire rope must be covered with a protective wrapper. Keep the wire rope away from acids, fumes, and other corrosives. Keep the wire rope away from heat that can dry out the lubricant. If the storage period will be long, lubricate the wire rope and perform periodic inspection given in the Service Manual at least monthly.

### Removing Wire Rope from Shipping Reel

#### CAUTION!

#### Wire Rope Damage!

Shipping reel must rotate when wire rope is unwound. Attempting to remove wire rope from a stationary reel can result in a “kinked” wire rope, and wire rope will be ruined.

1. Mount wire rope shipping reel on a shaft supported at both ends by jacks or blocks as shown in [Figure 4-47](#).

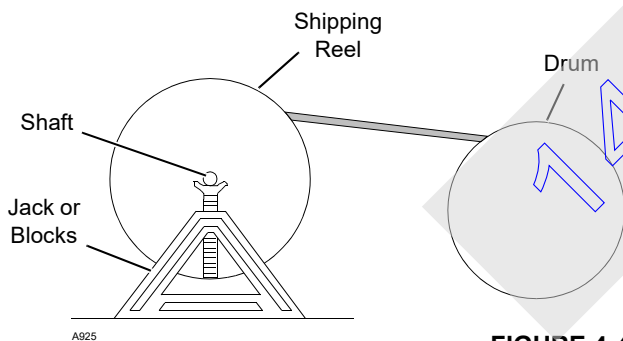


FIGURE 4-47

2. Provide a brake at shipping reel (see [Figure 4-48](#)) so wire rope can be wound tightly onto drum.

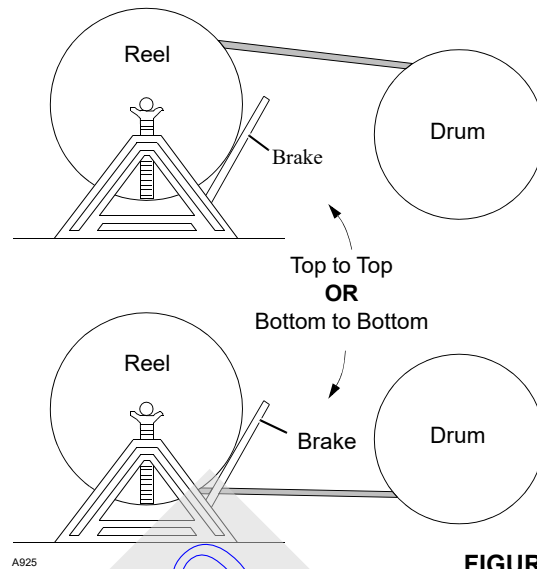


FIGURE 4-48

3. **Avoid a reverse bend when winding wire rope onto drum:** wind from top of reel to top of drum or from bottom of reel to bottom of drum as shown in [Figure 4-48](#).
4. Avoid dragging wire rope in dirt or around objects that can scrape, nick, cut, or crush wire rope.

### Seizing and Cutting Wire Rope

Apply tight seizings of annealed wire to the ends of all wire rope. If not done, the rope wires and strands may slacken. This action will result in overloading of some strands and underloading of others. Bird caging and breakage of the wire rope can occur.

Before cutting wire rope, apply seizings on both sides of the point where the cut will be made. Then cut the wire rope with a torch, rope cutter, or abrasive cut-off wheel.

See [Figure 4-49](#) for:

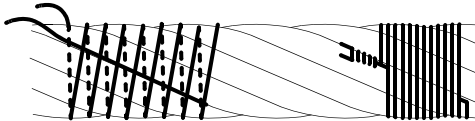
- Number of seizings to be applied to the ends of wire rope and to both sides of the point where a cut will be made
- Proper application method: each seizing should be one rope diameter long



A925

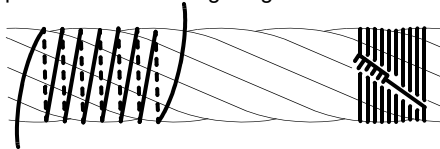
Wire Rope Type	Seizings Required
Preformed	1
Nonpreformed	3

Place free end of seizing wire in valley between two strands. Then wind seizing wire over free end as shown. Finally, twist and pull two ends of seizing wire together until seizing is tight.



View A Rope Diameter 1 in (26 mm) and Larger

Wind seizing wire around wire rope as shown. Then twist two ends of seizing wire together at center of seizing. Alternately twist and pull ends until seizing is tight.



View B Rope Diameter Smaller than 1 in (26 mm)

FIGURE 4-49

### Anchoring Wire Rope to Drum

See [Figure 4-50](#) for the following procedure.

Use the correct wedge part number for the size of wire rope being used; see parts drawing for the boom hoist drums or for the load drum shaft to obtain the correct part number.

1. Assemble wire rope and wedge to drum socket.
2. Tighten wedge by rapping back of wedge with a brass drift pin and hammer.

### **! WARNING!** Falling Load Hazard!

Wire rope can be pulled out of drum if the following steps are not taken:

- Install straight wedge so corrugated side is against wire rope
- Install wedge so end of wire rope extends past end of wedge, but not out of drum socket
- Make sure seizing is not under wedge. Remove seizing if it interferes with assembly

A925

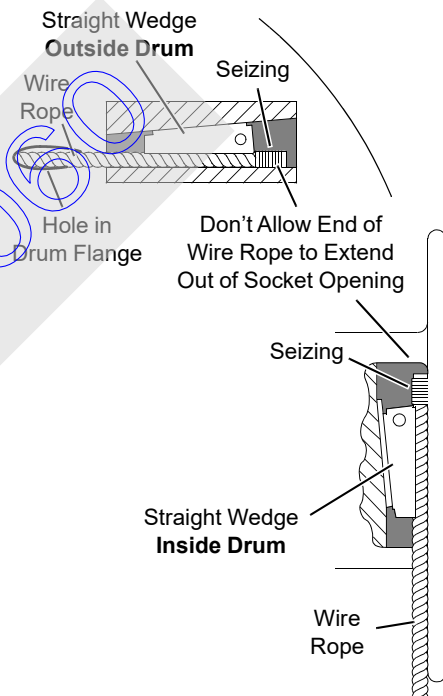


FIGURE 4-50

**THIS PAGE INTENTIONALLY LEFT BLANK**

14001060

## Winding Wire Rope onto Drum

See Drum and Lagging Chart in Capacity Chart Manual for correct size of drum laggings, if used.

See Wire Rope Specifications Chart in Capacity Chart Manual for correct type, size, and amount of wire rope to be installed on load drums.

See Boom Assembly Drawing at end of this section for correct type, size, and amount of wire rope to be installed on boom hoist drum.

1. Carefully inspect drums and all rope guides, rollers, and sheaves for defects that can cause wire rope to wear or be cut. If defects cannot be fixed, replace faulty parts.
2. Apply tension to wire rope as it is wound slowly onto drum.

First wrap must be tight against drum flange for approximately three-fourths of drum diameter (see [Figure 4-51](#)).

3. Tap adjacent wraps against each other with a soft metal or wooden mallet.

Use extreme care not to put twists or turns in wire rope; allow rope to assume its natural lay.

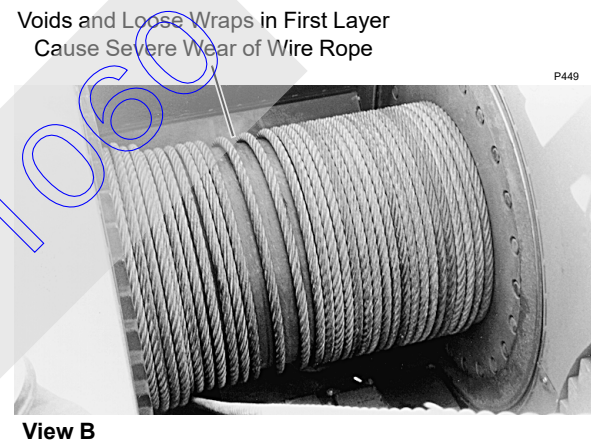
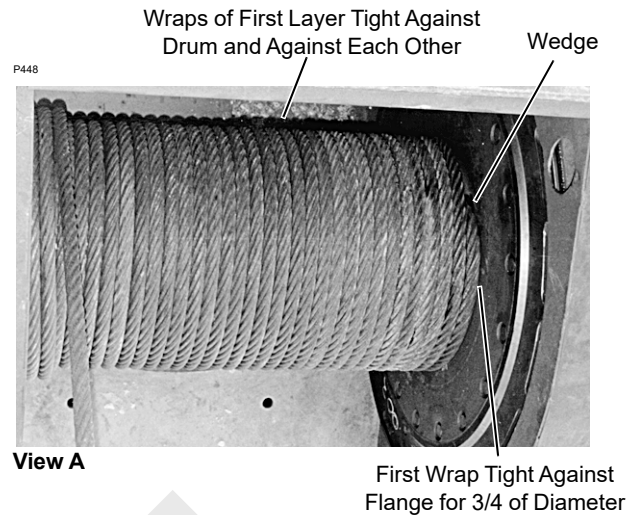


FIGURE 4-51

### CAUTION!

#### Wire Rope Damage!

Voids or spaced wraps in first layer (see View B, [Figure 4-51](#)) will permit movement and a wedging action with subsequent layers. Wedging action will cause crushing and abrasion of wire rope.

Never allow wire rope to “cross wind” on drums.

## Anchoring Wire Rope to Socket and Wedge

 **WARNING**  
**Falling Load Hazard!**

- Inspect all parts prior to use. Do not use parts that are cracked or otherwise defective.
- Remove minor nicks, burrs, or rough edges from socket, wedge, or pin by lightly grinding. Do not reduce original dimensions by more than 10%.
- Do not reinstall shipping material (bolt, plastic strap, or wire) in hole of wedge or socket after assembling. Discard these materials because they can prevent wedge from tightening in socket.
- Only use a wedge and socket which are correct size for wire rope being used. Do not mix and match parts from one assembly with parts from another assembly.
- Terminator™ socket and wedge has “go” and “no-go” holes to check for proper rope size.
- Attach wire rope clip to dead end of wire rope after assembling wire rope to wedge and socket.

See [Figure 4-52](#) for the following procedure.

1. Assemble wire rope and wedge to socket so live end of wire rope is in a straight line with socket pin hole. Refer to correct and incorrect assemblies in [Figure 4-51](#).
2. Allow dead end of wire rope to extend past end of socket amount shown.
3. Allow wire rope to assume its natural lay.
4. Pull against wedge and live end of wire rope enough to tighten wedge in socket.

Use a brass hammer to seat wedge and wire rope as deep into socket as possible.

5. Attach a wire rope clip to dead end of wire rope using one of the right methods shown. Rope clip will aid in preventing wire rope from being pulled out of socket.

**NOTE:** Use Right Method A only if wire rope clip is small enough to be securely tightened to dead end. Right Method C is only for a terminator socket and wedge.

6. After socket is pinned in place, hoist load slowly so wedge seats tight. *Do not shock load socket and wedge.*

 **WARNING**  
**Falling Load Hazard!**

Wire rope can break if the following precaution is not observed:

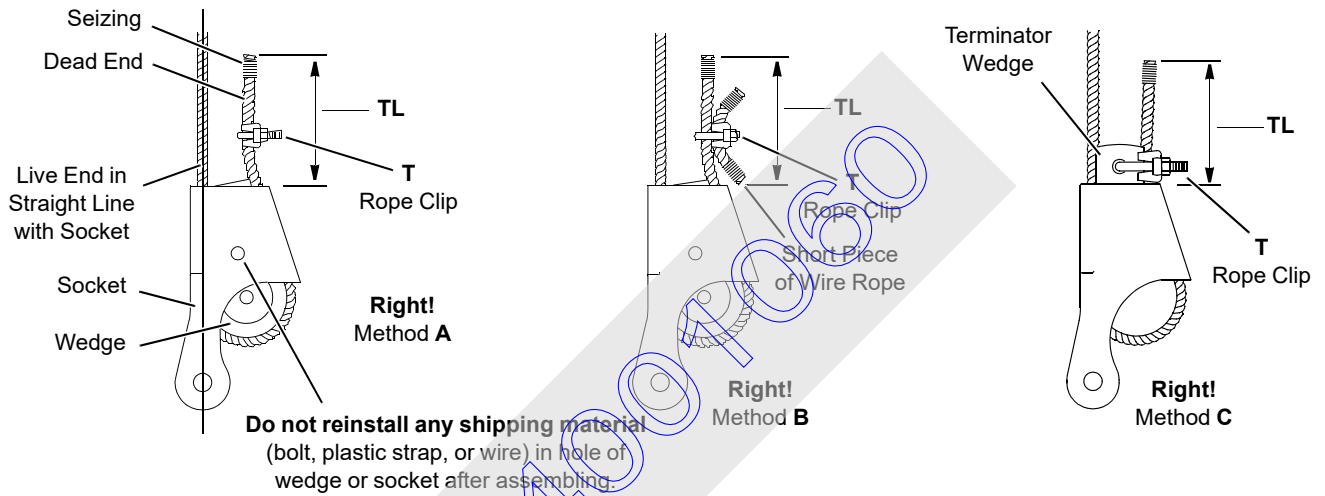
- Do not attach dead end of wire rope to live end of wire rope with wire rope clip. Wire rope clip will transfer load from live side of wire rope to dead end, seriously weakening attachment.

<b>TL (Tail Length)</b>
<b>Standard 6 to 8 Strand Wire Rope</b>
Minimum of 6 rope diameters, but not less than 6 in (152 mm)
<b>Rotation Resistant Wire Rope</b>
Minimum of 20 rope diameters, but not less than 6 in (152 mm)

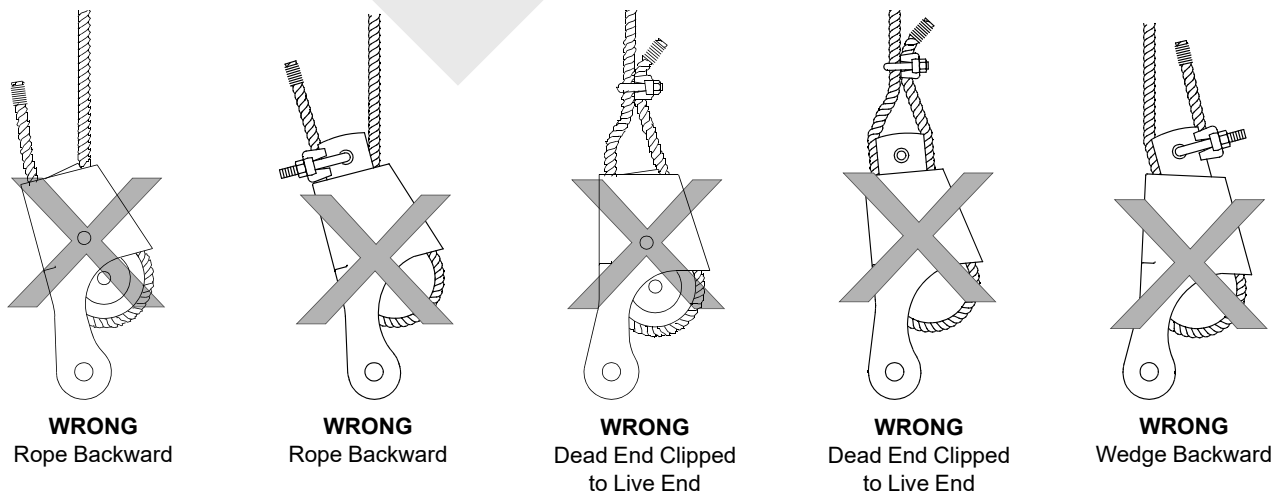
**T (Rope Clip Nut Torque)**

inch (mm)	Wire Rope/Clip Size			
	7/8 (22,23)	1 (25,4)	1-1/8 (28,58)	1-1/4 (31,75)
<b>Torque</b>				
* ft/lbs (kN/m)	225 (0,30)	225 (0,30)	225 (0,30)	360 (0,49)

\* Tightening torque values shown are based on threads being clean, dry and free of lubrication



**ALL ARE DANGEROUS AND PROHIBITED!**



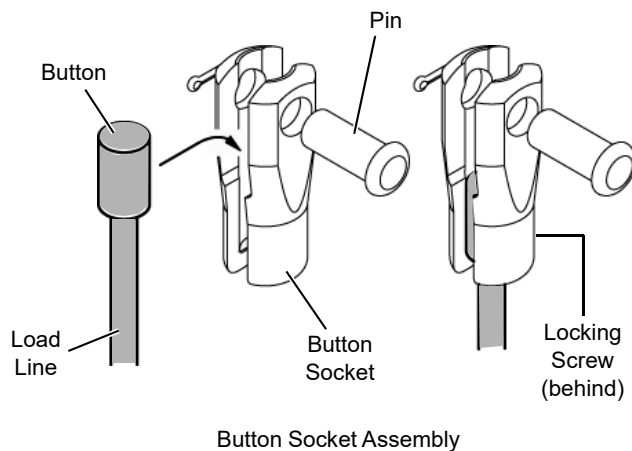
**FIGURE 4-52**

A925

## Anchoring Wire Rope to Button Socket

See [Figure 4-53](#) for the following procedure.

1. Remove pin from socket.
2. Install button end of load line in socket.
3. Pin socket to anchor point.
4. Securely tighten locking screw.



**FIGURE 4-53**

## Breaking in Wire Rope

After installing a new wire rope, break it in by operating it several times under a light load at reduced speed. This practice allows the wire rope to form its natural lay and the strands to seat properly.

**NOTE:** Wire rope will stretch during the break-in period, reducing the wire rope's diameter as the strands compact around the core.

The dead wraps of wire rope on the drum can become slack during operation, even if the utmost care is used during installation of the wire rope. This slackening is caused by the normal stretch that occurs in a new wire rope under tension

and periodically throughout the wire rope's life from release of the load.

When slackness is noted, tightly wind the dead wraps of wire rope onto the drum. If left uncorrected, a wedging action with subsequent layers will occur, and the resultant abrasion may cause broken wires in the dead wraps.

## Pad Eye Usage for Wire Rope Reeving

See [Figure 4-54](#) for the following procedure.

### General

Some rotation-resistant wire rope supplied by Manitowoc is equipped with a Number 1.5 pad eye welded to the leading end of the wire rope.

A rigging line can be attached to the pad eye to make it easier to reeve the load block.

### Safety

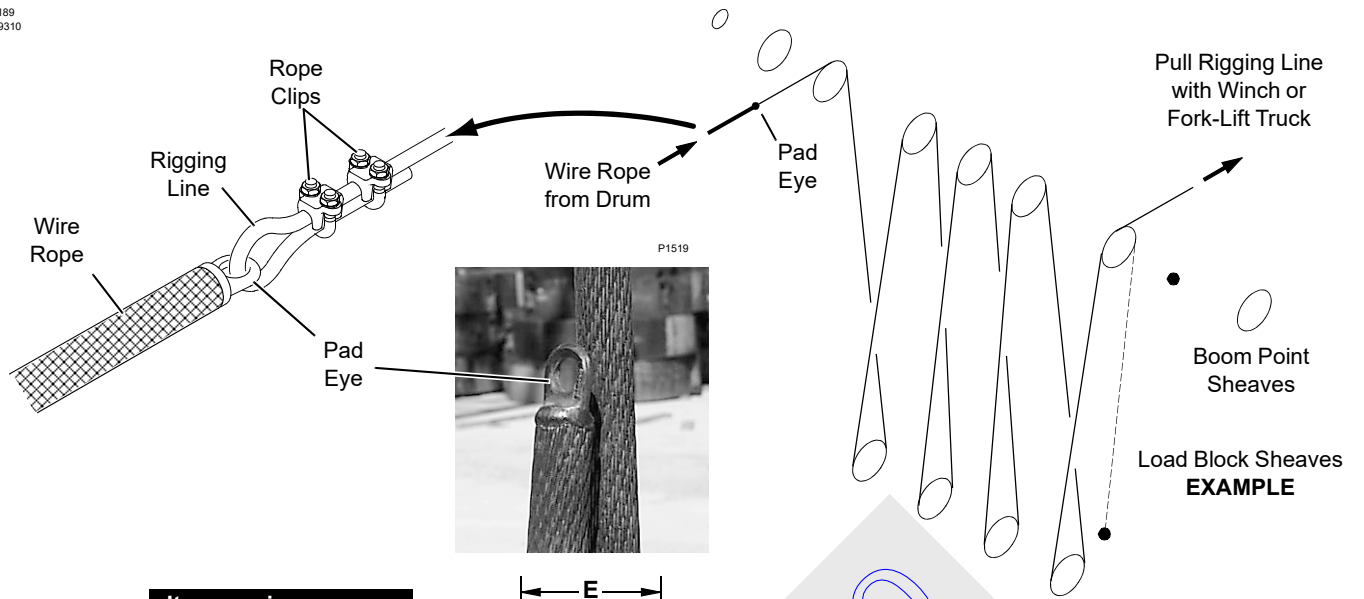
1. For Number 1.5 pad eye, do not exceed 1,000 lb (4,45 kN) single line pull.
2. Make sure rigging line and attaching hardware (clips and rope connectors) are rated for at least 1,000 lb (4,45 kN) line pull.
3. Inspect pad eye prior to each use. **Replace it if:**
  - Any original dimension has changed ([Figure 4-54](#))
  - Cracks or breaks exist in metal or weld

**! WARNING**  
**Flying Part Hazard!**

Pad eye on end of wire rope has been provided **for reeving purposes only**. Any other use is neither intended nor approved.

Pad eye can break and fly apart with considerable force if it is overloaded, not used properly, or not maintained properly.

A1189  
A09310



Item	in	mm
A	0.63	16,00
B	0.25	6,35
C	1.00	25,40
D	0.44	11,18
E	1.13	28,70
F	0.16	4,06
G	1.31	33,27

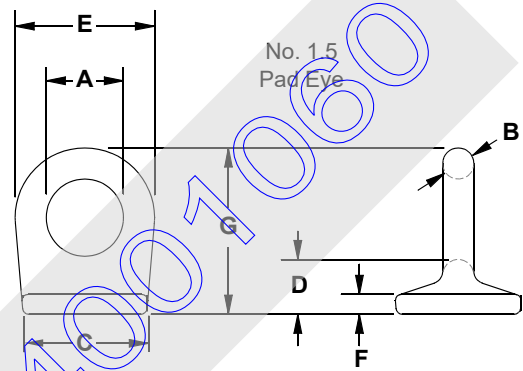
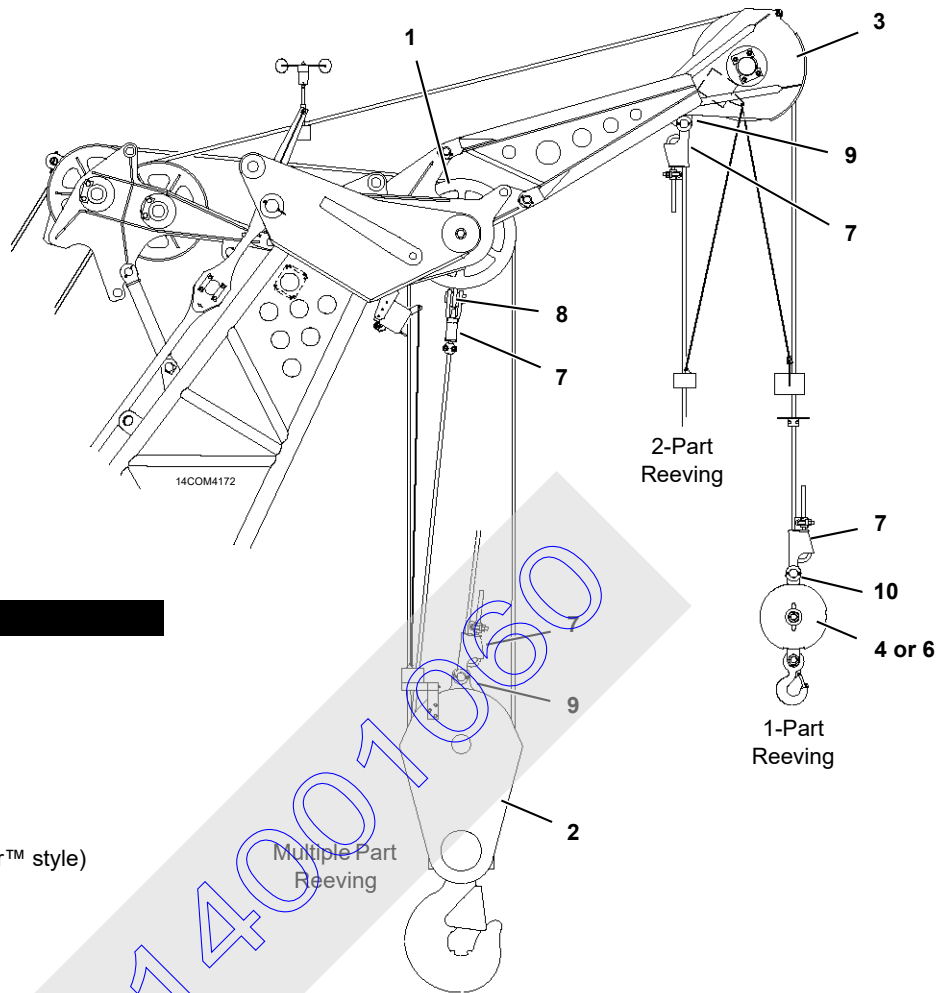


FIGURE 4-54





Item	Description
1	Lower Boom Point
2	Load Block (multiple sheave)
3	Upper Boom Point
4	Weight Ball
5	Jib Point
6	Load Block (single sheave)
7	Socket and Wedge (Terminator™ style)
8	Dead-End Link
9	Dead-End Lug
10	Swivel
11	Dead-End Adapter Link
12	Button Socket

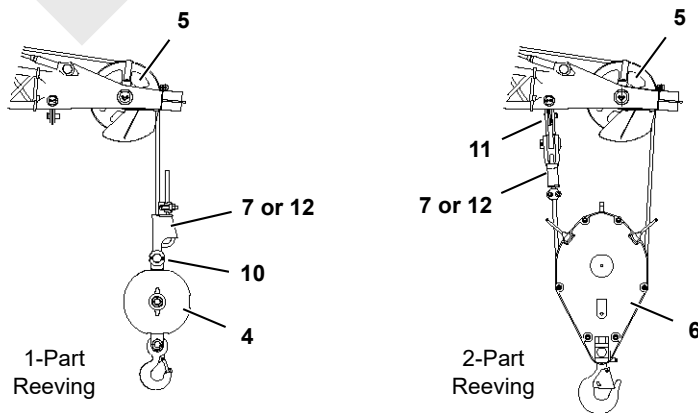


FIGURE 4-55

## LOAD LINE REEVING

### Wire Rope Specifications

See Wire Rope Specifications Chart in Capacity Chart Manual for the following information:

- Parts of line required for various loads
- Wire rope lengths and notes about hoisting distance for various parts of line
- Maximum spooling capacity of load drums

### CAUTION

#### Wire Rope Damage!

Avoid wire rope damage from improper fleet angle or contact with adjacent parts. Do not hoist load block or hook and weight ball any closer to boom or jib points than specified in reeving diagrams ([Figure 4-57](#)).

### Wire Rope Installation

See Wire Rope Installation on [Page 98](#) for the following instructions:

- Anchoring wire rope to drums
- Installing wire rope on drums
- Anchoring wire rope to socket and wedge

## Liftcrane

### Reeving Diagrams

See [Figure 4-57](#) for suggested reeving diagrams.

See [Figure 4-55](#) for component identification and dead-end locations in boom and jib.

### Dead-End Locations – Lower Boom Point

Depending on reeving requirements, it may be necessary to switch the middle and right sheave clusters (as viewed from rear) to properly position the dead-end link. See Lower Boom Point Assembly on [Page 89](#) for instructions.

### Guide Sheave Identification

See [Figure 4-56](#) for identification of wire rope guide sheaves in the boom and jib strut.

The guide sheaves *must* be positioned at the specified dimensions to ensure proper fleet angles.

### WARNING

#### Falling Load Hazard!

Avoid damage to wire rope or wire rope guides. Route wire rope from load drums through proper sheaves in wire rope guides as shown in [Figure 4-55](#) and [Figure 4-56](#). Failing to route wire rope as shown can cause wire rope to break and load to fall.

### Load Blocks

Refer to the Boom and Jib Assembly Drawings at the end of this section for load blocks and weight balls available from Manitowoc.

### WARNING

#### Falling Load Hazard!

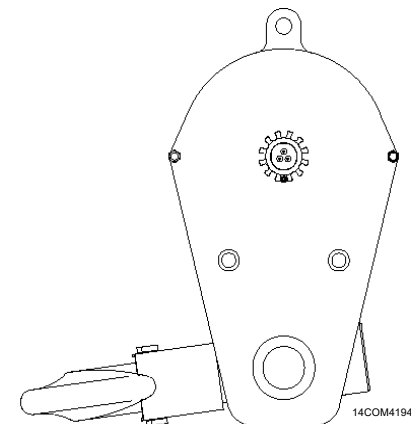
Load block capacity must be equal to or greater than weight of load to be handled. Load block can fail if overloaded, allowing load to fall.

### WARNING

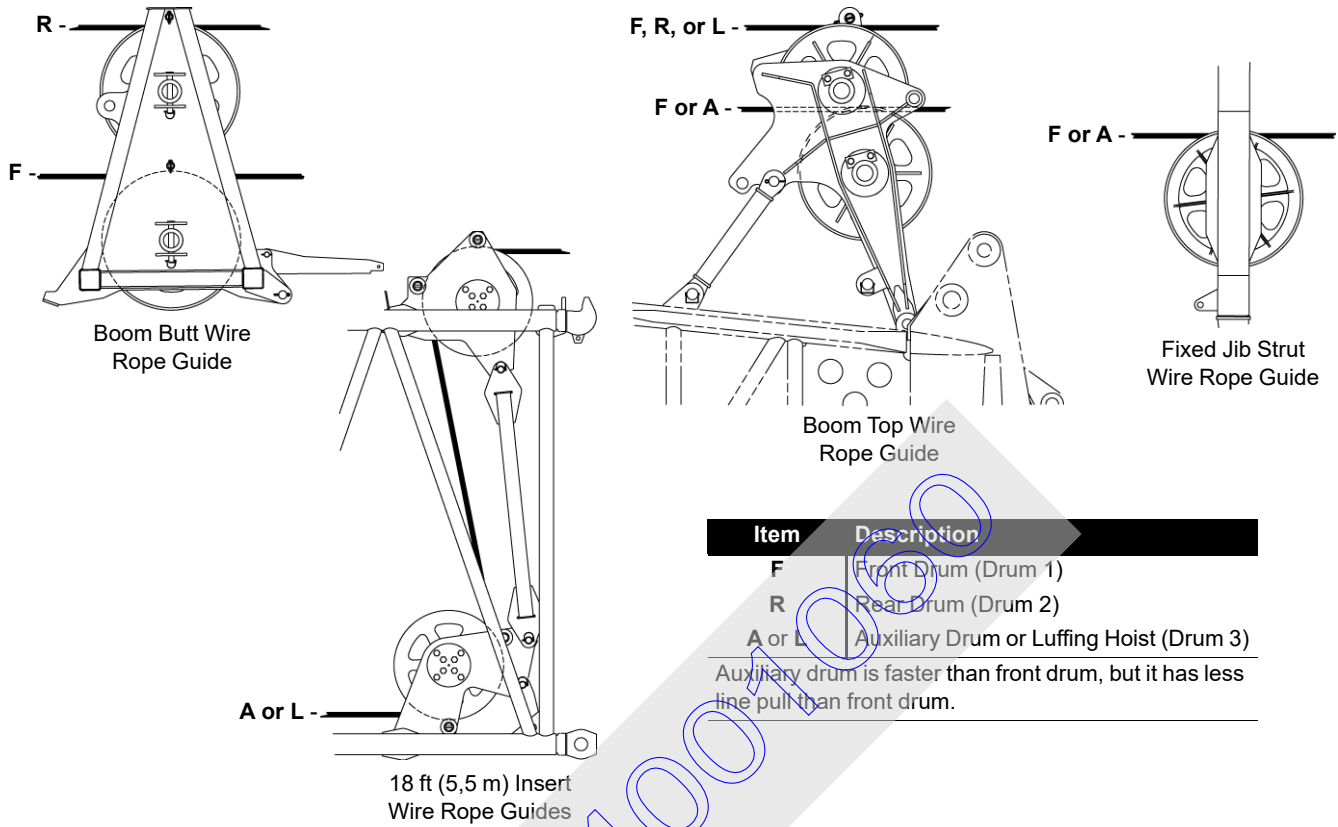
#### Avoid Death or Serious Injury!

Exercise care when block is standing in vertical position, as the potential for tipping exists. Potential causes of tipping are unstable work area, boom movement and the reeving process.

If work area is unstable, lay block flat on side plate, as shown below.



All Views from Right Side of Crane

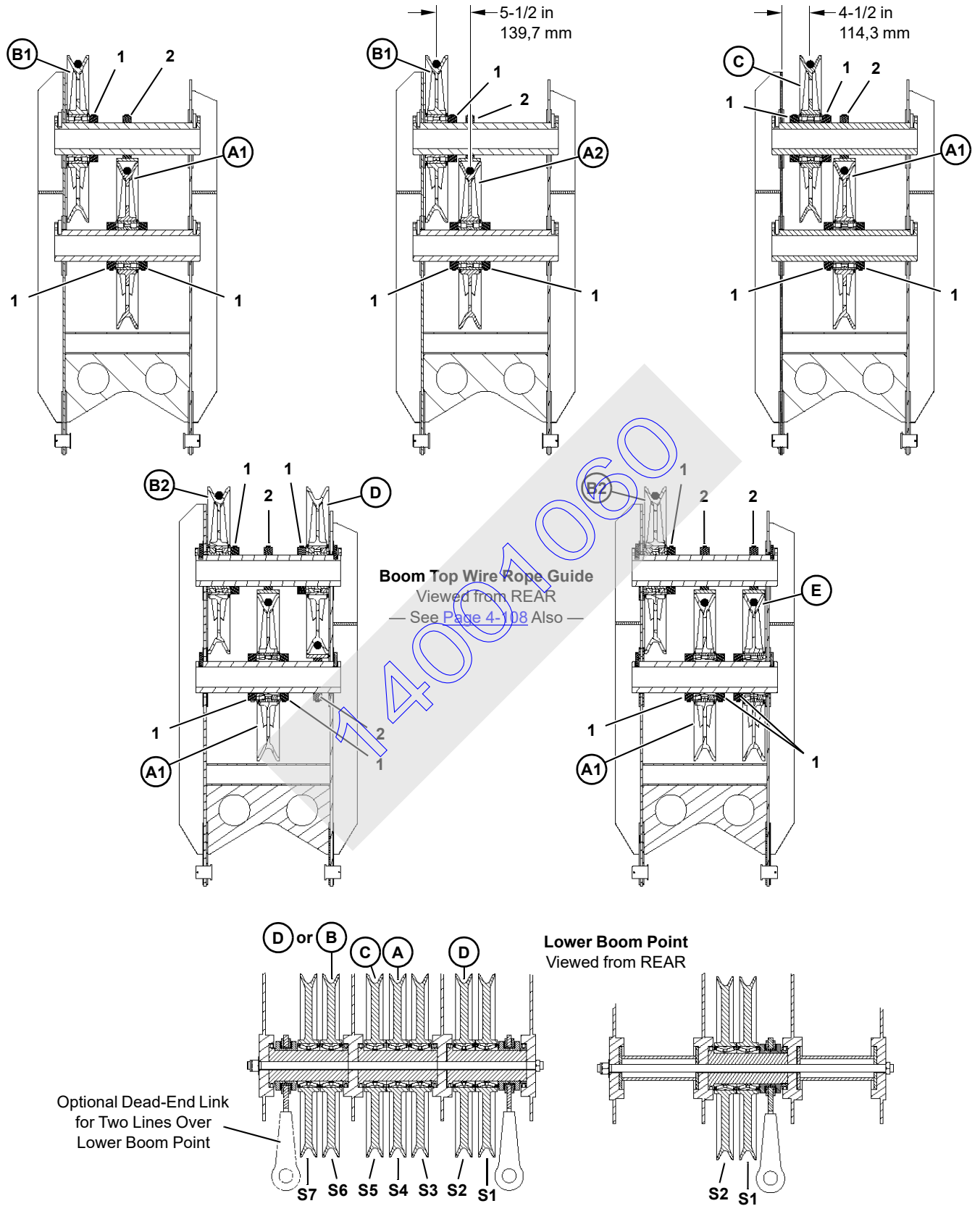


Boom Top Wire Rope Guide Sheave Positions

Sheave	Position	Rope Routing
(A1)	Centered on shaft with two clamp assemblies (1) Requires one clamp assembly (2)	Rope from F or A drum to upper boom point, fixed jib point, luffing jib point, or lower boom point S4
(A2)	At dimension given with two clamp assemblies (1)	Rope from F or A drum to upper boom point, fixed jib point, luffing jib point, or lower boom point S5
(B1)	Flush against left side of frame with one clamp assembly (1)	Rope from F or R drum to lower boom point sheave S6 or to luffing jib point
(B2)	Flush against left side of frame with one clamp assembly (1)	Rope from F or R drum to lower boom point sheave S6
(C)	At dimension given with two clamp assemblies (1)	Rope from F or R drum to lower boom point sheave S5
(D)	Flush against right side of frame with one clamp assembly (1). Requires one clamp assembly (2)	Rope from L drum to luffing jib main strut or rope from F or R drum to lower boom point sheave S2
(E)	Flush against right side of frame with one clamp assembly (1). Requires one clamp assembly (2)	Rope from L drum for auxiliary line

14COM4173  
14COM4174  
14COM4175  
14COM4176

FIGURE 4-56



14COM4177  
14COM4179

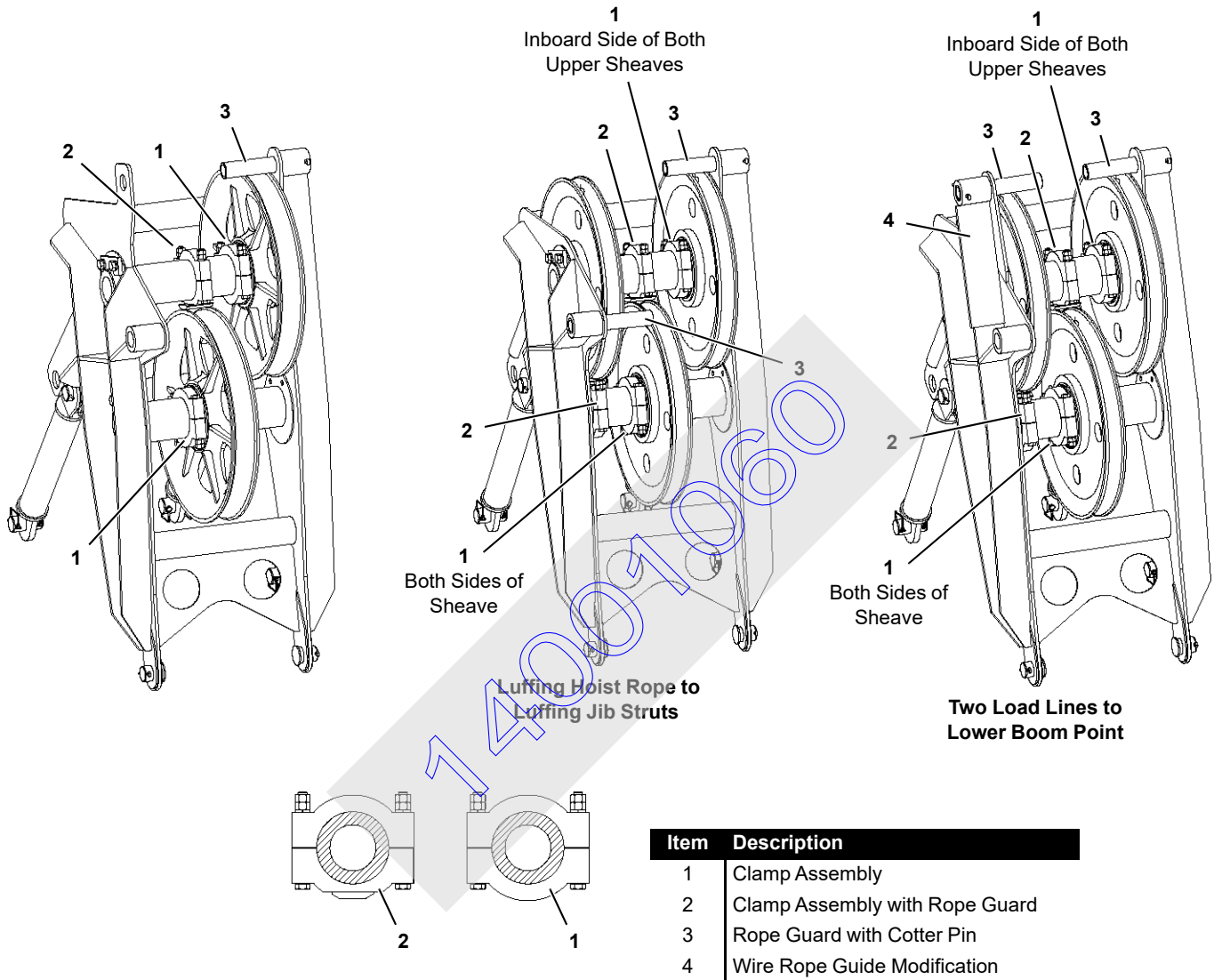
FIGURE 4-56 continued

**THIS PAGE INTENTIONALLY LEFT BLANK**

14001060

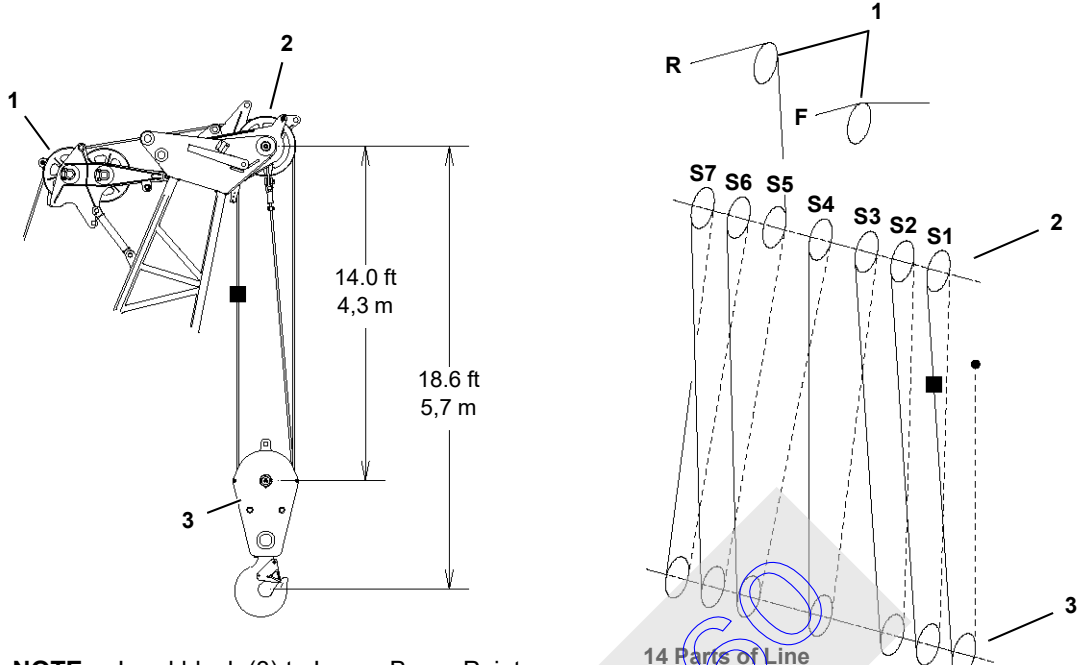
14COM4178a

**Boom Top Wire Rope Guide  
Rope Guard Installation**

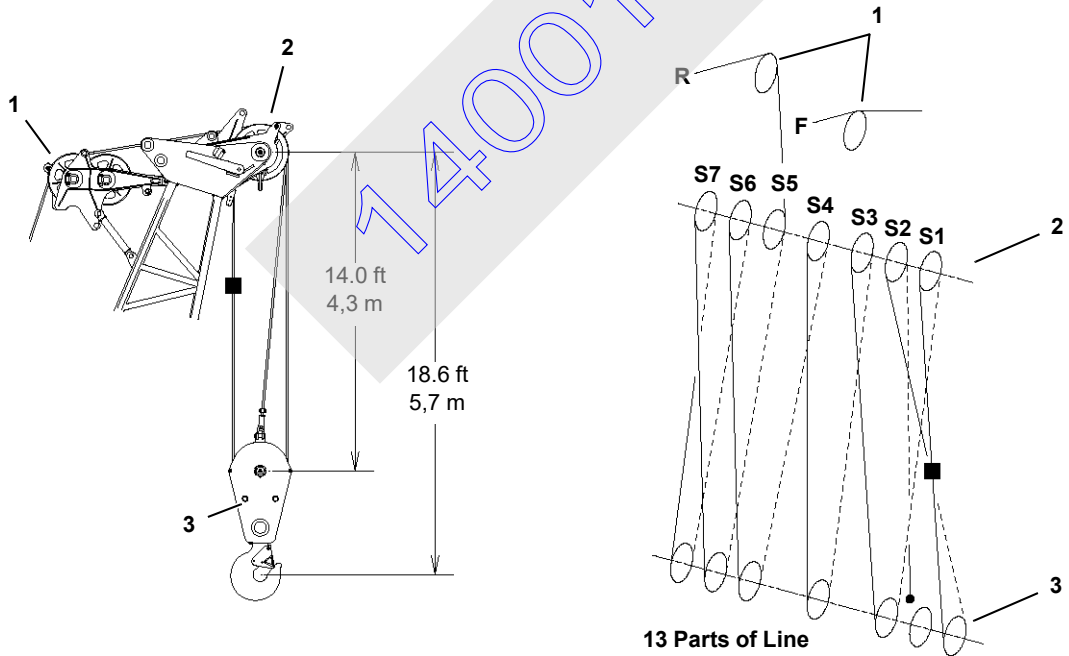


**FIGURE 4-56 continued**

6064-1\_2



**NOTE:** Load block (3) to Lower Boom Point (2) minimum distance is controlled by 2-1/2° fleet angle



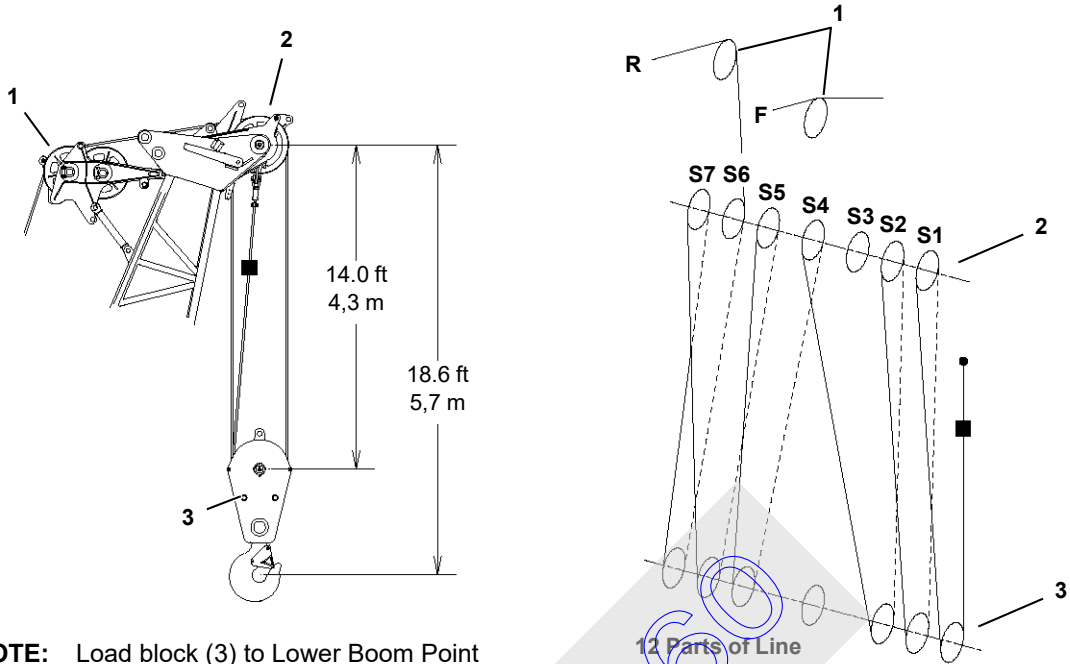
Item	Description	Item	Description
1	Boom Top Wire Rope Guide	F	Front Drum (Drum 1)
2	Upper Boom Point (see <a href="#">Figure 4-56</a> )	R	Rear Drum (Drum 2)
3	Load Block — 220 USt (199,6 t)		

- Dead-End Socket And Wedge
- Block-Up Limit Weight

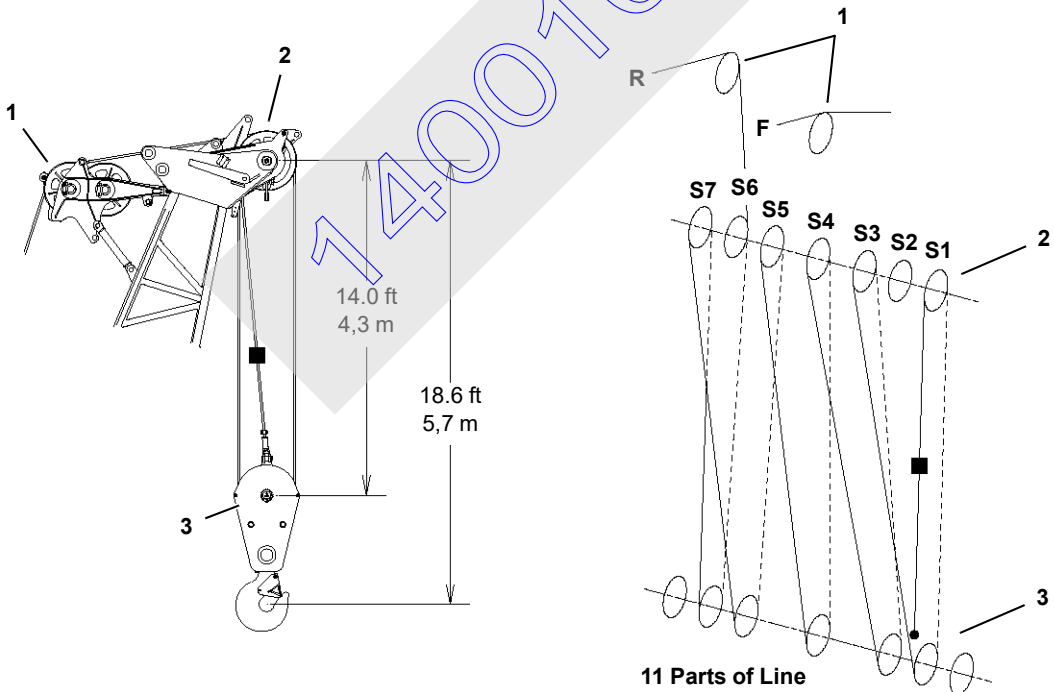
FIGURE 4-57



6064-3\_4



**NOTE:** Load block (3) to Lower Boom Point (2) minimum distance is controlled by 2-1/2° fleet angle

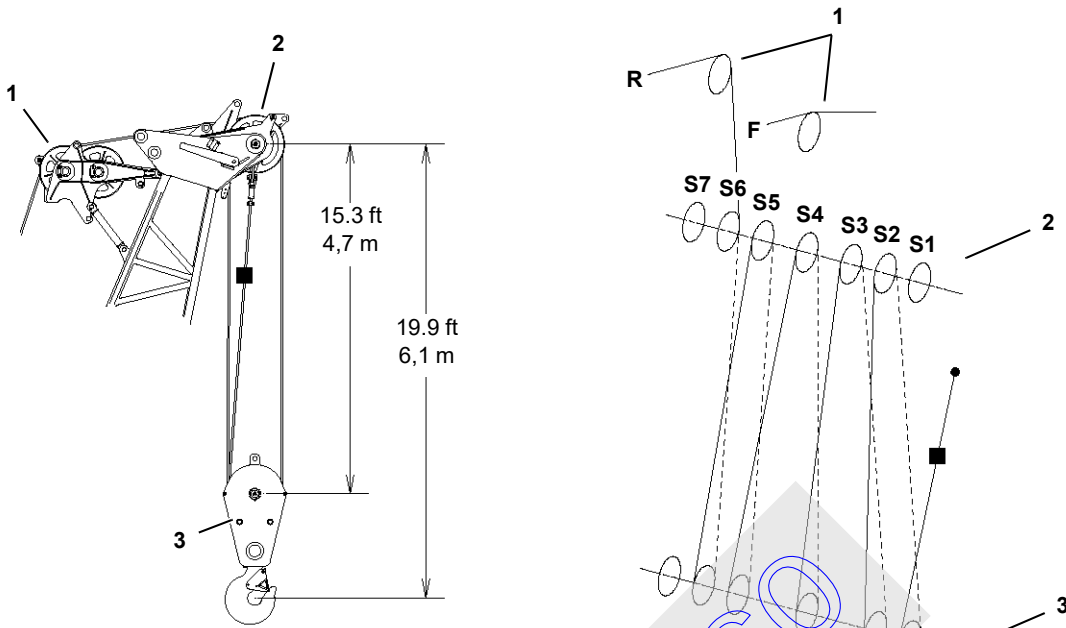


Item	Description	Item	Description
1	Boom Top Wire Rope Guide	F	Front Drum (Drum 1)
2	Upper Boom Point (see <a href="#">Figure 4-56</a> )	R	Rear Drum (Drum 2)
3	Load Block — 220 USt (199,6 t)		

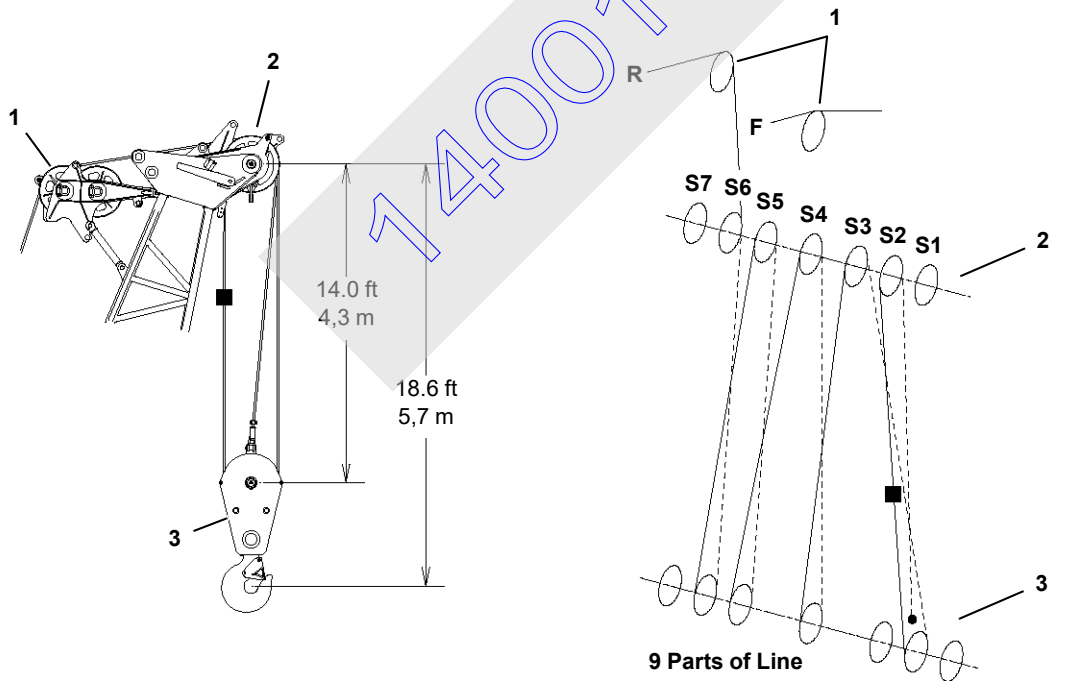
- Dead-End Socket And Wedge
- Block-Up Limit Weight

FIGURE 4-57 continued

6064-5\_6



**NOTE:** Load block (3) to Lower Boom Point (2) minimum distance is controlled by 2-1/2° fleet angle

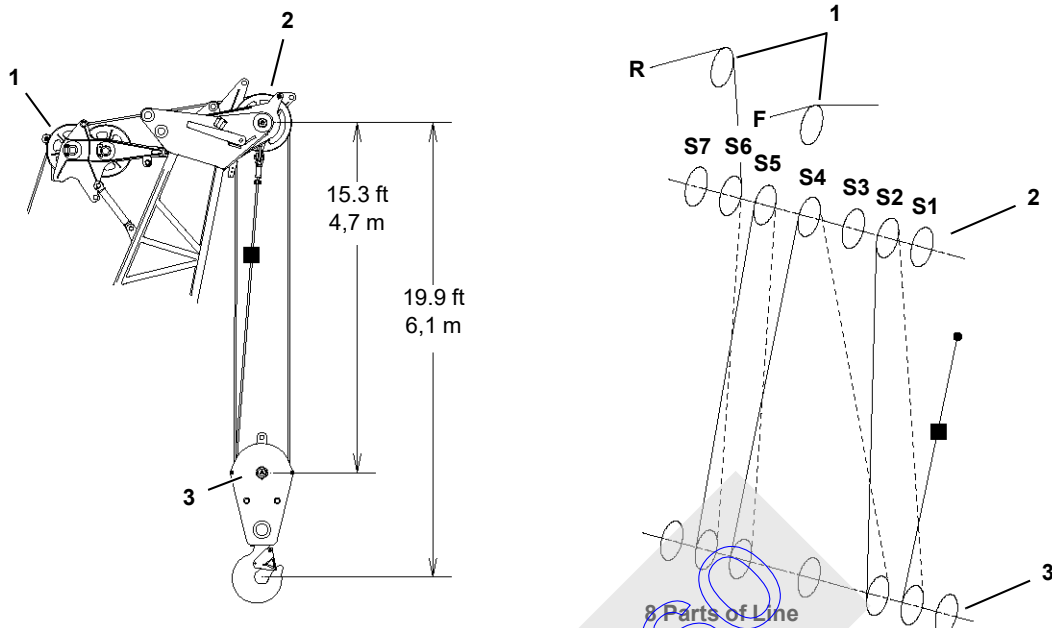


Item	Description	Item	Description
1	Boom Top Wire Rope Guide	F	Front Drum (Drum 1)
2	Upper Boom Point (see <a href="#">Figure 4-56</a> )	R	Rear Drum (Drum 2)
3	Load Block — 220 USt (199,6 t)		

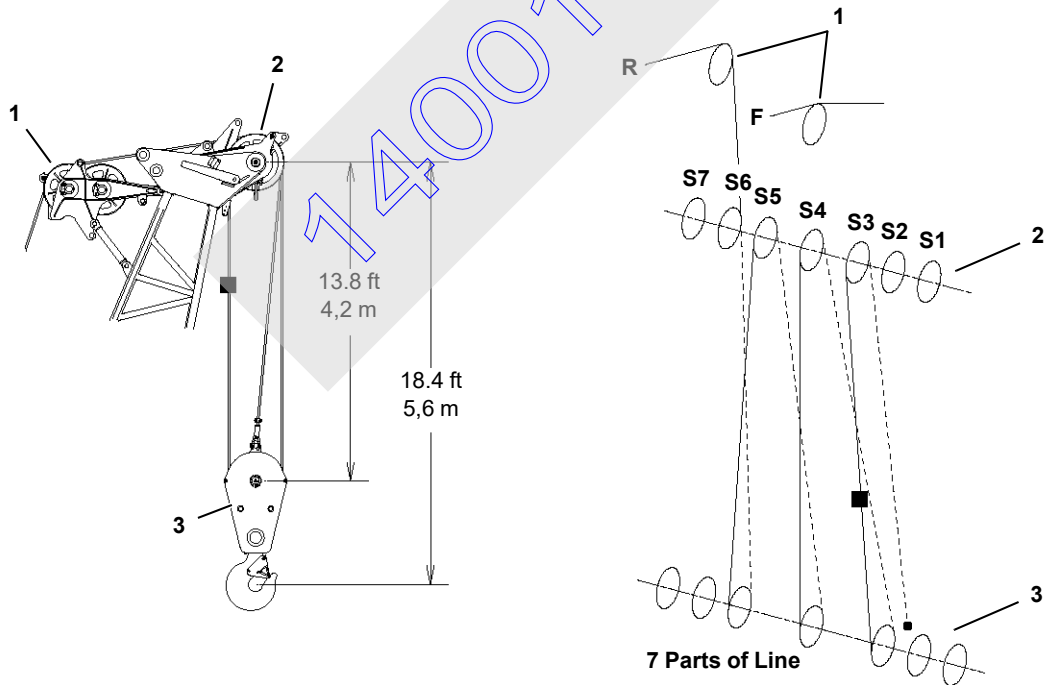
- Dead-End Socket And Wedge
- Block-Up Limit Weight

FIGURE 4-57 continued

6064-7\_8



**NOTE:** Load block (3) to Lower Boom Point (2) minimum distance is controlled by 2-1/2° fleet angle

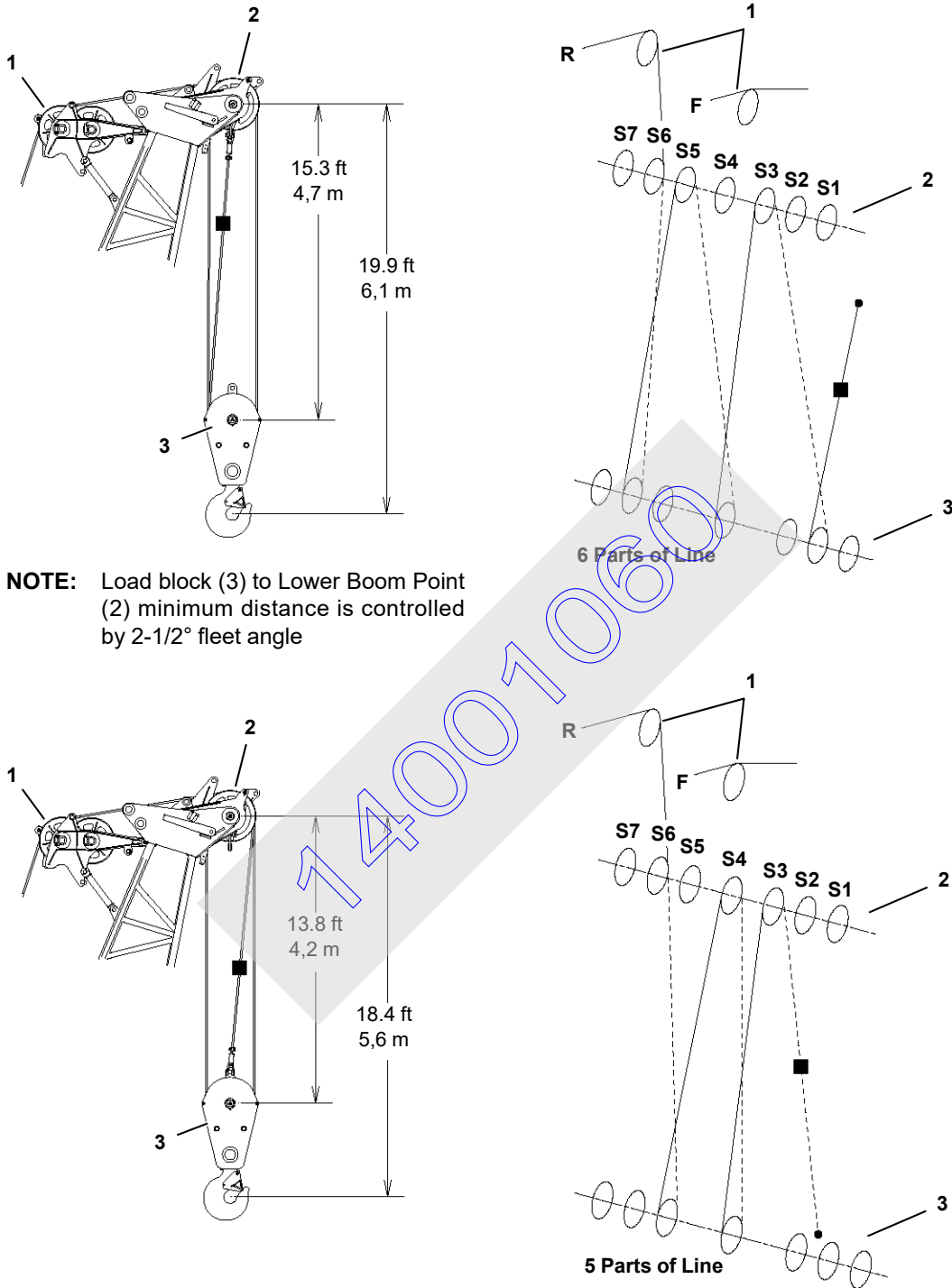


Item	Description	Item	Description
1	Boom Top Wire Rope Guide	F	Front Drum (Drum 1)
2	Upper Boom Point (see <a href="#">Figure 4-56</a> )	R	Rear Drum (Drum 2)
3	Load Block — 220 USt (199,6 t)		

- Dead-End Socket And Wedge
- Block-Up Limit Weight

FIGURE 4-57 continued

6064-9\_10



**NOTE:** Load block (3) to Lower Boom Point (2) minimum distance is controlled by 2-1/2° fleet angle

Item	Description	Item	Description
1	Boom Top Wire Rope Guide	F	Front Drum (Drum 1)
2	Upper Boom Point (see <a href="#">Figure 4-56</a> )	R	Rear Drum (Drum 2)
3	Load Block — 220 USt (199,6 t)		

- Dead-End Socket And Wedge
- Block-Up Limit Weight

FIGURE 4-57 continued

6064-11\_13

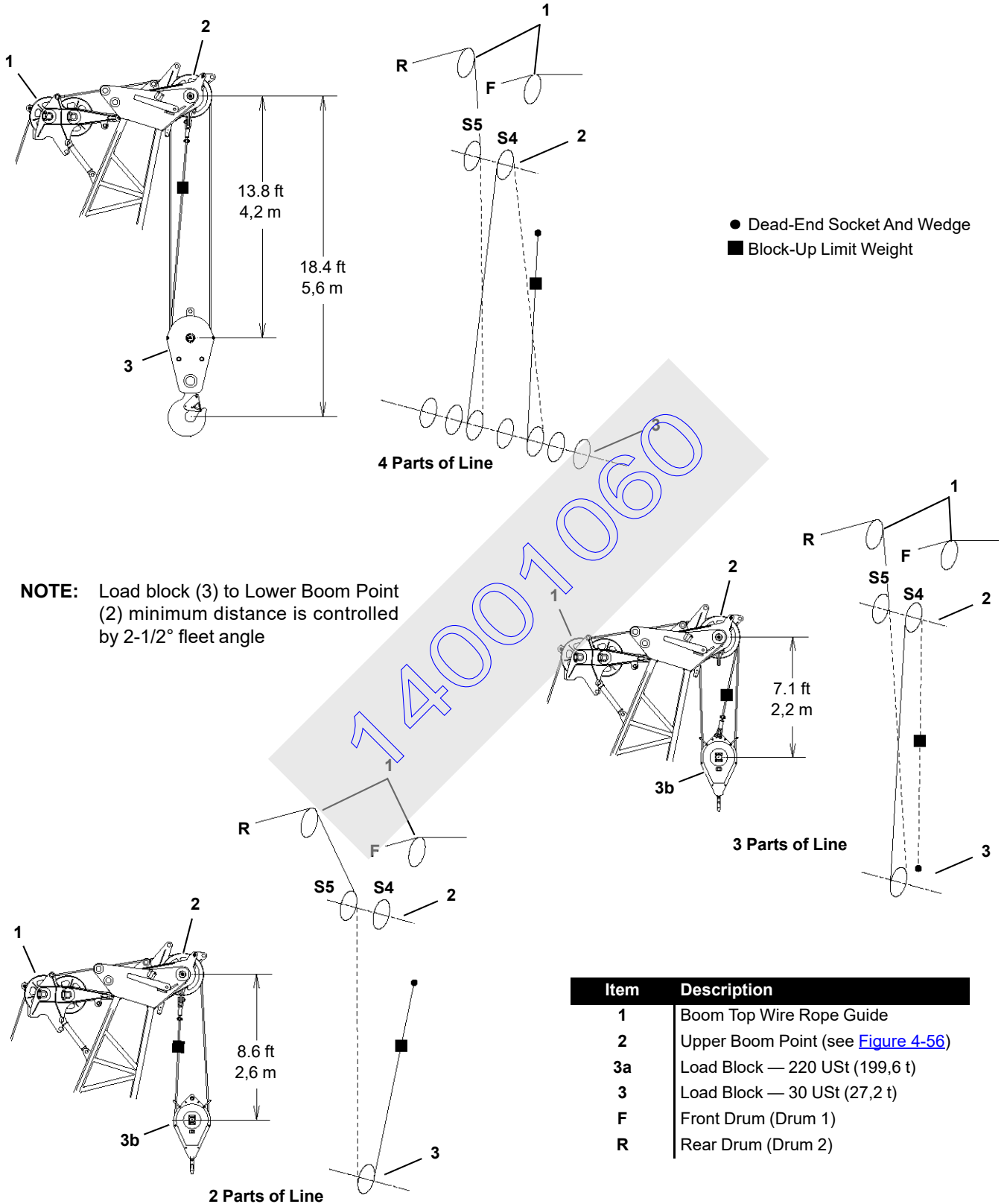


FIGURE 4-57 continued

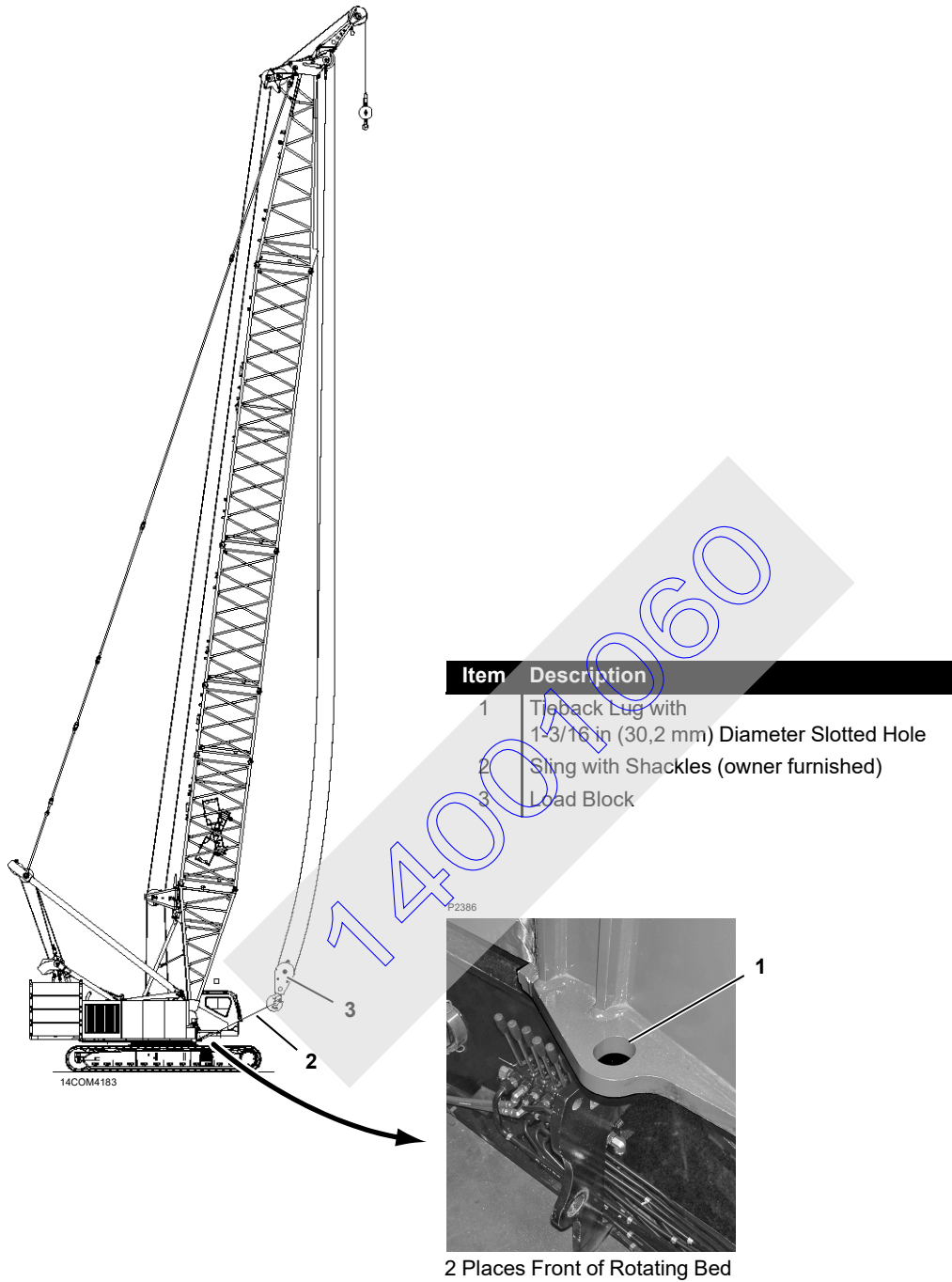


FIGURE 4-58

## LOAD BLOCK TIEBACK

### General

Two lugs are provided on the front of the rotating bed (View A, [Figure 4-58](#)) for tying back the load block when not in use.

### Specifications

#### Shackle

See [Figure 4-58](#) for tieback hole diameter. Size the shackle accordingly.

#### Sling Length

The sling should be long enough to connect it to shackles in the tieback holes and to the hook of the freely suspended load block. This will prevent personnel from having to swing the block in, toward crane, to make the connection.

#### Sling Capacity

The slings must be capable of supporting the weight of the load block and half the weight of the wire rope suspended from the boom point. When sizing slings, take into account the dynamic affects of traveling and swinging the crane. **It is the crane user's responsibility to calculate this load.**

### CAUTION

Avoid damage to boom:

- Haul in load line only until tieback sling(s) is taut. Purpose of tieback is only to prevent load block from swinging when not in use.
- Do not tighten load line to point that load line rubs against lacings in boom sections or load block can bounce into lacings.

Operator, be aware that as you boom down load lines and tieback sling will tighten even more. Pay out load line while booming down so that you don't pull load block into boom. Damage to lacings or chords could result.

## BOOM HOIST REEVING

The boom hoist wire rope must be reeved between the gantry and mast sheaves as shown in [Figure 4-59](#).

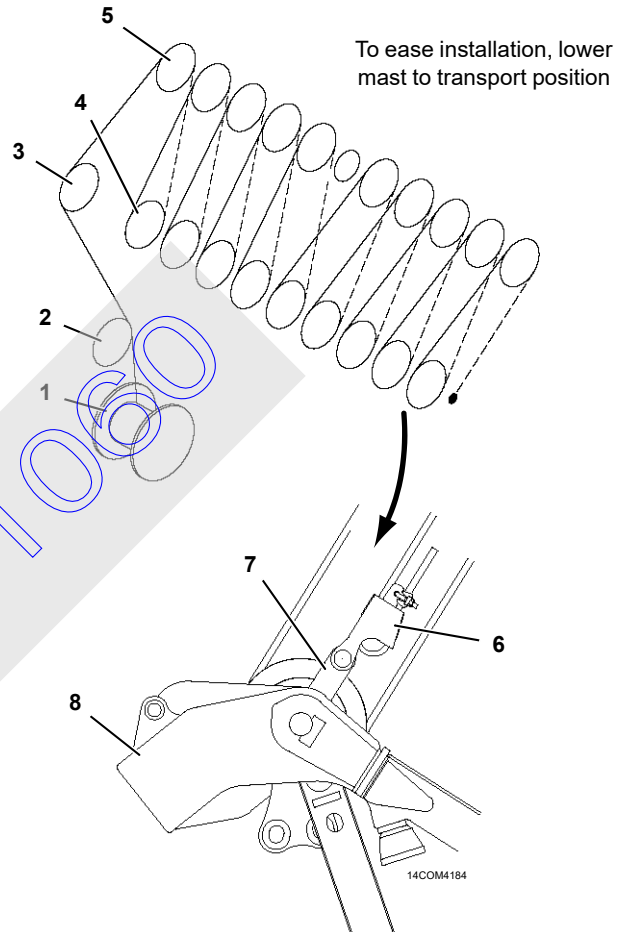
Manitowoc provides a 7/8 in (22 mm) terminator socket and wedge for anchoring the wire rope to the dead-end link in the gantry.

The wire rope tail length must be at least 6 in (152,4 mm).

## Wire Rope Installation

See Wire Rope Installation and Maintenance starting on [Page 98](#) for instructions on how to:

- Anchor wire rope to drum
- Install wire rope on drum
- Anchor wire rope to socket and wedge



Item	Description
1	Boom Hoist (Drum 4)
2	Fleeting Sheave (at gantry hinge pin)
3	Fleeting Sheave (in gantry)
4	Gantry Sheaves
5	Mast Sheaves
6	Socket and Wedge
7	Dead-End Link
8	Gantry

FIGURE 4-59



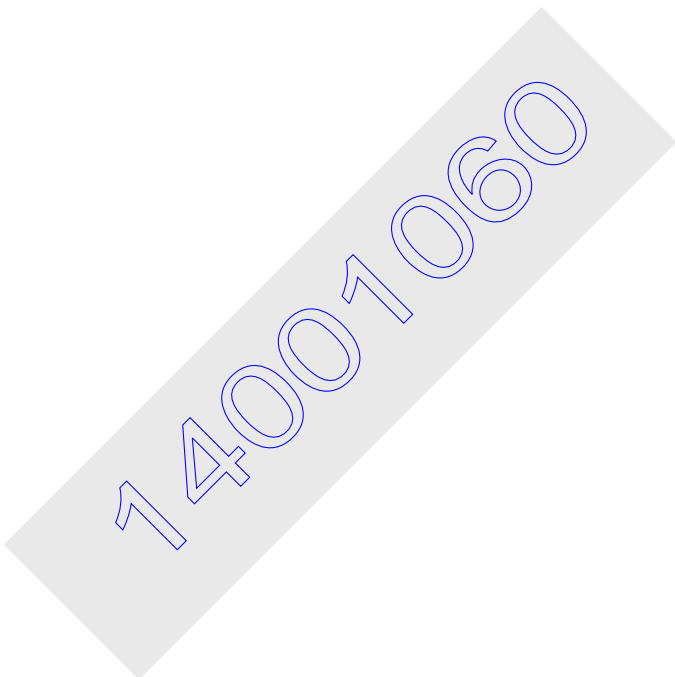
**THIS PAGE INTENTIONALLY LEFT BLANK**

14001060

# SECTION 5 LUBRICATION

## TABLE OF CONTENTS

Lubrication .....	5-1
Lube and Coolant Product Guide .....	5-1



**THIS PAGE INTENTIONALLY LEFT BLANK**

14001060

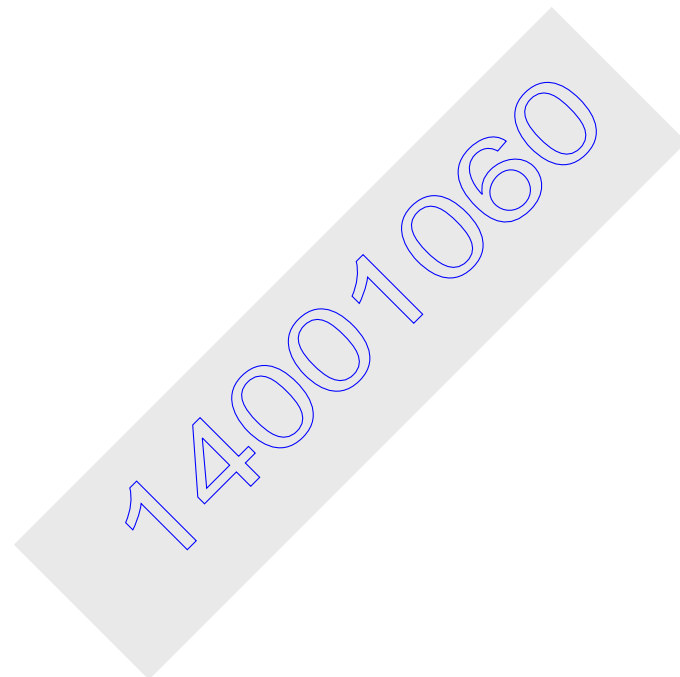
## SECTION 5 LUBRICATION

### LUBRICATION

See F2129 at the end of this section.

### LUBE AND COOLANT PRODUCT GUIDE

See the publication at the end of this section.



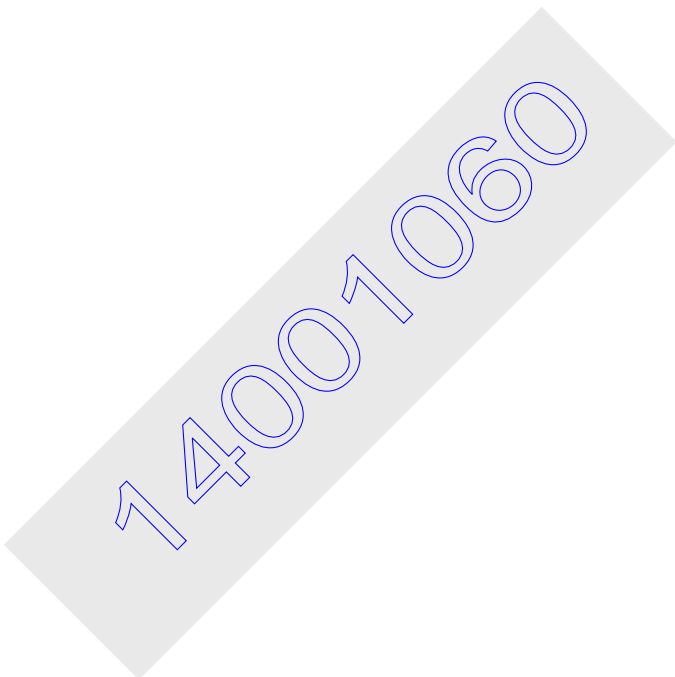
**THIS PAGE INTENTIONALLY LEFT BLANK**

14001060

# SECTION 6 MAINTENANCE CHECKLIST

## TABLE OF CONTENTS

Inspection and Maintenance Checklist .....	6-1
Fiberglass Maintenance .....	6-1



**THIS PAGE INTENTIONALLY LEFT BLANK**

14001060



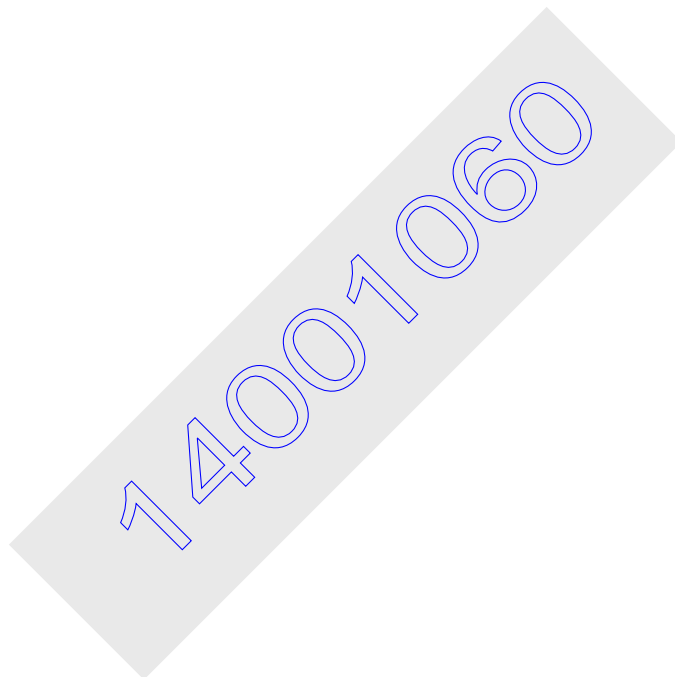
## SECTION 6 MAINTENANCE CHECKLIST

### INSPECTION AND MAINTENANCE CHECKLIST

See F2097 at the end of this section.

### FIBERGLASS MAINTENANCE

See Bulletin W04-009 at the end of this section.



*THIS PAGE INTENTIONALLY LEFT BLANK*

14001060

# ALPHABETICAL INDEX

Assembling, Disassembling, or Operating Crane Near Electric Power and Transmission Lines . . . .	2-15
Accessing Parts . . . . .	4-3
Accidents . . . . .	2-16
Assembly and Disassembly Area . . . . .	4-3
Assembly and Disassembly Notes . . . . .	4-3
Boom and Jib Assembly Drawings . . . . .	4-1
Boom and Jib Rigging . . . . .	4-69
Boom Disassembly Safety . . . . .	2-20
Boom Hoist Reeving . . . . .	4-119
Boom Ladder . . . . .	4-68
Cab Window Operation . . . . .	3-10
Change of Ownership Registration . . . . .	1-1
Circuit Breakers . . . . .	3-75
Cold Weather Heater Package . . . . .	3-75
Cold Weather Mast Operation . . . . .	4-5
Continuous Innovation . . . . .	2-1
Controls Identification and Function . . . . .	3-14
Crane Access Points . . . . .	2-4
Crane Assembly . . . . .	4-13
Crane Data . . . . .	1-1
Crane Disassembly . . . . .	4-44
Crane Orientation . . . . .	1-1
Crane Orientation . . . . .	4-1
Crane Weights . . . . .	1-1
Crane Weights . . . . .	4-4
Crane/Attachment Identification . . . . .	1-1
Displays . . . . .	3-48
Electrocution Hazard Devices . . . . .	2-27
English and Metric Conversions . . . . .	1-6
Environmental Protection . . . . .	2-18
Fiberglass Maintenance . . . . .	6-1
Fire Extinguishers . . . . .	2-16
General Safety . . . . .	4-1
Getting On or Off Crane . . . . .	2-4
Handling Components . . . . .	4-4
Identification and Location of Components . . . . .	1-2
Inspection and Maintenance Checklist . . . . .	6-1
Introduction . . . . .	1-1
Liftcrane Mast Capacities . . . . .	4-1
Limit Devices . . . . .	3-30
Load Block Tieback . . . . .	4-119
Load Line Reeving . . . . .	4-107
Lube and Coolant Product Guide . . . . .	5-1
Lubrication . . . . .	5-1
Lubrication . . . . .	5-1
Maintenance Checklist . . . . .	6-1
Manitowoc Dealer . . . . .	1-1
Multiple Crane Lifts . . . . .	2-28
Multiple Load Line Operation . . . . .	2-27
Nameplates and Decals . . . . .	2-1
Operating Controls And Procedures . . . . .	3-1
Operating Controls . . . . .	3-10
Operating Controls . . . . .	4-6



Operation . . . . .	3-33
Operational Aids . . . . .	2-13
Operator Manual/Capacity Chart Storage . . . . .	2-6
Optional Attachments . . . . .	4-1
Outline Dimensions . . . . .	1-4
Pedestal/Barge Mounted Cranes . . . . .	2-22
Personal Fall-Protection . . . . .	2-6
Personnel Handling Policy . . . . .	2-21
Pile Driving and Extracting . . . . .	2-26
Preparation for Cold Weather . . . . .	3-73
Preparing Crane for Operation . . . . .	3-33
Pre-Raising Checks . . . . .	4-44
Pre-Start Checks . . . . .	4-6
Reference to Past and Current Production in this manual . . . . .	1-1
Refueling . . . . .	2-16
Remote Controls . . . . .	3-45
Retaining Connecting Pins . . . . .	4-4
Safe Maintenance . . . . .	2-17
Safe Operating Practices . . . . .	2-8
Safety and Information Signs . . . . .	2-3
Safety Devices . . . . .	2-13
Safety Information . . . . .	2-1
Safety Messages . . . . .	2-1
Seat Controls . . . . .	3-32
Self-Erecting Equipment . . . . .	4-3
Setup And Installation . . . . .	4-1
Shipping Crane Components . . . . .	4-5
Shipping Data . . . . .	4-7
Signals . . . . .	2-12
Special Application/Service . . . . .	2-21
Standard Hand Signals for Controlling Crane Operations . . . . .	3-2
Stopping Engine/ Leaving Crane Unattended . . . . .	3-45
Swing Radius Barrier . . . . .	2-7
Symbol Identification . . . . .	3-4
Wind Conditions . . . . .	3-71
Wire Rope Installation . . . . .	4-98

14001060

14001060