

Operator's Manual



Crane Serial Number

The crane serial number is on the Crane Rating Manual in the lower right interior of the operator's cab. The crane serial number should always be furnished when ordering parts for the crane, or when corresponding with the Link-Belt Distributor or the Factory regarding the crane. The serial number is the only method of ensuring that the correct parts will be furnished.

In the event the serial number cannot be found on the Crane Rating Manual, a number is stamped on top of the bumper on the right side of the carrier and on the two position swing lock weldment. This number can then be used to help to identify the crane.

Operator's Manual



WARNING

CONSTRUCTION EQUIPMENT CAN BE DANGEROUS IF IMPROPERLY OPERATED OR MAINTAINED. THIS CRANE SHOULD BE OPERATED AND MAINTAINED ONLY BY TRAINED AND EXPERIENCED PEOPLE WHO HAVE READ, UNDERSTOOD, AND COMPLY WITH THE OPERATOR'S & MAINTENANCE MANUAL.

The productive life of construction equipment depends largely on the care and consideration given to it. This especially holds true for hydraulic cranes. This Operator's & Maintenance Manual was compiled to explain the procedures and adjustments necessary for proper operation of this crane.

A study of this Operator's Manual will acquaint the operator and service personnel with the construction of this crane. It will enable them to identify and remedy most problems that may occur. Any questions pertaining to the care and upkeep of this crane which are not covered in this Operator's Manual should be directed to your Link-Belt Distributor.

The Operator's Manual is stored in the pocket on the rear of the operator's seat. The Operator's Manual should remain in the cab and accessible at all times. **If the Operator's Manual becomes lost, damaged, or unreadable, it must be replaced before operating the crane.**

In addition to this Operator's & Maintenance Manual, a Parts Manual, Crane Rating Manual, and Safety Manual are supplied with the crane. Read and understand all safety guidelines before operating the crane. Additional copies of all manuals are available through your Link-Belt Distributor.

CALIFORNIA

Proposition 65 Warning

Diesel engine exhaust and some of its constituents, and certain vehicle components contain or emit chemicals known to the State of California to cause cancer, birth defects, and other reproductive harm.

Operator's Manual

Throughout this Operator's Manual, reference is made to the left, right, front, and rear pertaining to direction and locations. These reference directions are relative to the operator, sitting in the operator's seat with the upper directly over the front of the carrier (engine to the rear), unless otherwise stated.

Danger, warning, and caution captions as well as special notes are used throughout this Operator's Manual and on the crane to emphasize important and critical instructions. Labels, plates, decals, etc. should be periodically inspected and cleaned as necessary to maintain good legibility for safe viewing. **If any instruction, caution, warning, or danger labels, plates, or decals become lost, damaged, or unreadable, they must be replaced.** Information contained on such labels, plates, and decals is important and failure to follow the information they contain could result in an accident. Replacement labels, decals, and plates can be ordered through your Link-Belt Distributor. For the purpose of this Operator's Manual, and the labels which are placed on the crane, danger, warning, and caution captions and notes are defined as follows:



DANGER

An operating procedure, practice, etc. which, if not correctly followed, may result in severe personal injury, dismemberment, or loss of life.



WARNING

An operating procedure, practice, etc. which, if not correctly followed, may result in personal injury.

CAUTION

An operating procedure, practice, etc. which, if not correctly followed, may result in damage to or destruction of equipment or property.

NOTE

Note: An operating procedure step, condition, etc. which is essential in order for the process to be completed properly.

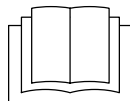

This symbol may appear in this Operator's Manual and/or on a label on the crane to alert personnel that additional instructions are included in the crane Operator's Manual.

Operator's Manual

General Index

A detailed Table Of Contents for each Section of this Operator's Manual is included at the beginning of each Section. The following is a description of each Section:

Section 1 – Operating Instructions Pages 1–1 Thru 1–170

Section 1 includes the necessary information for safe, productive crane operation. It includes the nomenclature and operation of all control switches, levers, pedals, and instrumentation of the crane.

Section 2 – Lubrication And Preventive Maintenance Pages 2–1 Thru 2–34

Section 2 includes the necessary information for proper lubrication and preventive maintenance for daily operations. It includes the check/change intervals and procedures for maximizing the service life of the crane under normal working conditions. It also includes lubrication types and specifications approved for use in the crane.

Section 3 – Periodic Adjustments Pages 3–1 Thru 3–20

Section 3 includes the adjustments which must be made periodically to keep the crane in proper, safe working order. It includes the procedures and necessary information for adjusting the brakes, mechanical linkages, and hydraulic pressures on the crane.

Section 4 – Attachments Pages 4–1 Thru 4–24

Section 4 includes the use and operation of the crane attachments. It includes the necessary information for installation, erection, storage, and removal of the auxiliary lifting sheave and lattice fly.

Section 5 – General Information Pages 5–1 Thru 5–26

Section 5 includes general information on the Crane Rating Manual and serial number as well as wire rope specifications, inspection, replacement, connections, and reeving. General specifications for the crane are also included.

Section 6 – Fundamental Terms Pages 6–1 Thru 6–4

Section 6 includes a list of terms which are used to refer to crane functions, assembly, operation, and maintenance. These terms are defined as to how they are used in this Operator's Manual.

Operator's Manual

Table Of Contents

| | |
|---|-------------|
| Crane Nomenclature | 1-1 |
| On Delivery | 1-1 |
| Operating Safety | 1-1 |
| General Safety Rules | 1-2 |
| Operator Awareness | 1-2 |
| Electrical Dangers | 1-8 |
| Radio Frequency Or Electro Magnetic Interference (RFI Or EMI) | 1-11 |
| Protective Equipment | 1-11 |
| Signal Persons And Bystanders | 1-11 |
| Crane Inspections And Adjustments | 1-12 |
| Wire Rope | 1-14 |
| Crane And Area Clearance | 1-15 |
| Weights, Lengths, And Radii | 1-15 |
| Traveling | 1-20 |
| Leaving The Station | 1-21 |
| Personnel Handling Guidelines | 1-22 |
| Introduction | 1-22 |
| Authorization | 1-22 |
| Equipment | 1-23 |
| Maintenance, Lubrication, And Adjustments | 1-23 |
| Inspection And Rigging | 1-24 |
| Crane Test Procedures | 1-25 |
| Operation And Safety | 1-26 |
| Additional Requirements For Offshore Cranes | 1-27 |
| Operator's Cab | 1-29 |
| Fire Extinguisher | 1-30 |
| Top Hatch | 1-30 |
| Top Hatch Wiper And Washer | 1-30 |
| Top Hatch Window | 1-30 |
| Top Hatch Sunscreen | 1-30 |
| Upper Operator's Cab Fuse Panel | 1-30 |

Operator's Manual

| | |
|--|------|
| Windshield Washer Reservoir | 1-30 |
| Bubble Level | 1-30 |
| Upper Electrical Control Panel | 1-31 |
| Manual Boom Override Connector | 1-31 |
| RCL Bypass Keyswitch | 1-31 |
| Upper Fuse Box | 1-32 |
| Right Side Control Console | 1-33 |
| Seat Console Control Switches | 1-35 |
| Crane Control Display | 1-37 |
| Engine Data And Aftertreatment Control Screen | 1-40 |
| Crane Control Display Brightness Adjustment | 1-42 |
| Engine Diesel Particulate Filter (DPF) | 1-43 |
| Engine DPF Regeneration Indicators | 1-43 |
| High Exhaust System Temperature Indicator Light | 1-44 |
| Engine DPF Regeneration Inhibit Switch | 1-44 |
| DPF (Parked) Manual Regeneration | 1-46 |
| Cab Heater Operation | 1-48 |
| Diesel Fired Warm-water Cab Heater | 1-48 |
| To Start The Diesel Fired Warm-water Cab Heater | 1-48 |
| To Stop The Diesel Fired Warm-water Cab Heater | 1-48 |
| Engine Dependant Warm-water Cab Heater (If Equipped) | 1-49 |
| To Start The Cab Heater | 1-49 |
| To Stop The Cab Heater | 1-49 |
| Cab Heater Shutoff (If Equipped) | 1-49 |
| Air Conditioning (If Equipped) | 1-49 |
| Steering Column And Wheel | 1-51 |
| Transmission Controls | 1-53 |
| Shifting The Transmission | 1-53 |
| Foot Operated Controls | 1-54 |
| Combination Steering | 1-55 |
| Conventional Steer Mode | 1-55 |
| Rear Wheel Steer Mode | 1-55 |

Operator's Manual

| | |
|--|-------------|
| 4-Wheel Steer Mode | 1-55 |
| Crab Steer Mode | 1-55 |
| Changing Steering Modes | 1-55 |
| Hydraulic Pump Disconnect (If Equipped) | 1-56 |
| To Engage The Main Pump | 1-56 |
| To Disengage The Main Pump | 1-56 |
| Operator's Seat | 1-57 |
| Radio Operation | 1-58 |
| System Menu | 1-61 |
| Battery Alarm Operation | 1-61 |
| Auxiliary Input | 1-61 |
| Preset Stations | 1-61 |
| Weather Band Operation | 1-62 |
| MP3/WMA Operation | 1-63 |
| Media Requirements | 1-63 |
| ID3 Support | 1-63 |
| Installing a USB Device | 1-63 |
| MP3/WMA Directory Search | 1-63 |
| iPod Operation | 1-63 |
| Accessing iPod Mode | 1-63 |
| Turning The iPod ON/OFF | 1-64 |
| iPod Search Mode | 1-64 |
| Bluetooth® Operation | 1-64 |
| Bluetooth Menu Options | 1-64 |
| Pairing A Bluetooth Device | 1-65 |
| Answering A Call | 1-65 |
| BT Audio (A2DP) | 1-65 |
| Care And Maintenance | 1-66 |
| Ignition | 1-66 |
| Interference | 1-66 |
| Radio Troubleshooting | 1-67 |
| Winch And Right Swing View Cameras | 1-68 |

Operator's Manual

| | |
|--|-------------|
| Camera Monitor | 1-69 |
| Split Screen Function | 1-71 |
| NORMAL/MIRROR Function | 1-74 |
| UP/DOWN Function | 1-75 |
| SCAN Function | 1-76 |
| RESET | 1-77 |
| Care and Maintenance | 1-77 |
| Power Panel | 1-79 |
| Circuit Breakers | 1-79 |
| Fuse Blocks | 1-79 |
| Mega Fuses | 1-79 |
| Hour Meter | 1-79 |
| Battery Disconnect Switches | 1-79 |
| Outrigger Operation | 1-80 |
| To Extend Outrigger Beams | 1-80 |
| To Extend Outrigger Jacks – Raise The Crane | 1-82 |
| To Retract Outrigger Jacks – Lower The Crane | 1-82 |
| To Retract Outrigger Beams | 1-82 |
| Crane System Controls | 1-83 |
| Engine Throttle | 1-83 |
| Throttle Lock System | 1-83 |
| Swing System | 1-85 |
| Swing Brake Pedal | 1-85 |
| Swing Control Lever | 1-85 |
| Travel Swing Lock | 1-85 |
| Swing Park Brake | 1-86 |
| 360° Swing Lock | 1-87 |
| Wire Rope Winch System | 1-88 |
| Warm-Up Procedure | 1-88 |
| Front Winch Control Lever (If Equipped) | 1-89 |
| Rear Winch Control Lever | 1-89 |
| Winch Operation | 1-89 |

Operator's Manual

| | |
|--|-------------|
| Winch Control Switch(es) | 1-89 |
| High Speed Hoist Or Lower | 1-89 |
| Winch Disable | 1-89 |
| Drum Rotation Indicators | 1-90 |
| First Layer/Third Wrap Indicator (If Equipped) | 1-90 |
| Boom Hoist System | 1-91 |
| Boom Telescope System | 1-91 |
| Boom Extend Modes | 1-92 |
| Boom Telescope Mode Selection | 1-92 |
| Boom Telescope Control Pedal | 1-93 |
| To Extend The Boom Sections | 1-93 |
| To Retract The Boom Sections | 1-93 |
| Boom Operating And Error Messages | 1-93 |
| Emergency Telescope Operation | 1-94 |
| To Manually Retract A Boom Section | 1-95 |
| To Manually Extend A Boom Section | 1-96 |
| Fine Metering System (If Equipped) | 1-97 |
| Crane Monitoring System | 1-98 |
| Wind Speed Indicator | 1-98 |
| Operating In Wind And Lightning | 1-99 |
| Boom Angle Indicator | 1-100 |
| Anti-Two Block Warning System | 1-100 |
| Lockout Clip | 1-101 |
| Rated Capacity Limiter | 1-102 |
| System Description | 1-102 |
| Display Unit | 1-102 |
| System Operation | 1-106 |
| System Bypass | 1-106 |
| System Inoperative Or Malfunctioning | 1-106 |
| System Navigation | 1-107 |
| Configuration Selection | 1-108 |
| To Select Rigging And Travel Modes | 1-118 |

Operator's Manual

| | |
|---|--------------|
| Cancel Audible Alarm And Reset Function Limiters | 1-118 |
| Operator Settable Alarms | 1-119 |
| Setting Angle, Length, Height, Radius, And Swing Operator Settable Alarms | 1-121 |
| Operator Defined Area Alarm | 1-129 |
| Outrigger Position Screen (If Equipped) | 1-131 |
| Boom Telescope Animation Display | 1-133 |
| Boom Operating Messages | 1-135 |
| Normal Operation Messages | 1-135 |
| Active System Faults | 1-137 |
| Active System Faults Messages | 1-138 |
| Boom Telescope Diagnostics | 1-141 |
| Boom Telescope Diagnostics Screen | 1-142 |
| Sensor Data | 1-143 |
| Highlight Data Menu | 1-144 |
| About Menu | 1-145 |
| Function Time Monitoring | 1-146 |
| Telematics | 1-147 |
| Transmitting Data | 1-147 |
| Entering And Exiting The Upper Operator's Cab | 1-150 |
| Upper Guard Rails | 1-151 |
| Break-In Period | 1-153 |
| Before Starting Operations | 1-153 |
| Boom Distortion Due To Thermal Effects Of The Sun | 1-154 |
| Engine Starting Procedure | 1-154 |
| Engine Shutdown Procedure | 1-155 |
| Cold Engine Starting | 1-155 |
| Electric Engine Block Preheater | 1-156 |
| Jump Starting The Crane | 1-157 |
| Crane Operation | 1-158 |
| During Operation | 1-158 |
| Hand Signals | 1-160 |
| Pick And Carry Operation | 1-160 |

Operator's Manual

| | |
|---|--------------|
| Traveling The Crane | 1-161 |
| Job Site Travel | 1-161 |
| Highway Travel | 1-162 |
| Counterweight Removal And Installation (If Equipped) | 1-163 |
| Counterweight Removal | 1-163 |
| Counterweight Installation | 1-165 |
| Lifting The Crane | 1-166 |
| Towing The Crane | 1-167 |
| Transporting The Crane | 1-168 |
| Suspension Height Adjustment | 1-169 |
| Crane Storage | 1-170 |
| Short Term Storage | 1-170 |
| Long Term Storage | 1-170 |

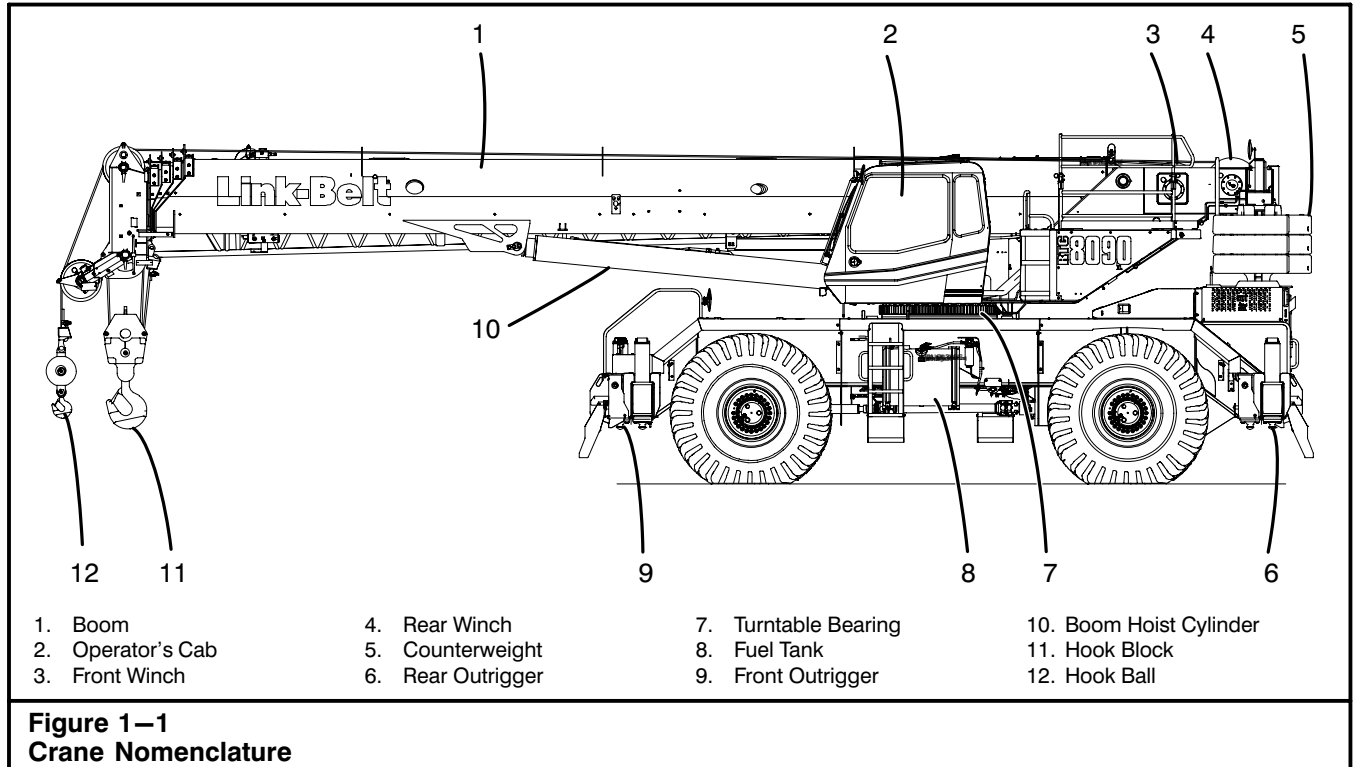

On Delivery

When a new crane is delivered, follow the instructions outlined in the latest version of Technical Bulletin General Series #213.

Operating Safety

Remember SAFETY every day. Someone's LIFE may depend on it, **MAYBE YOUR OWN**.

Safe operations of a hydraulic crane requires a well trained, qualified operator. Crane operation is more involved than it may appear, and operation by a careless or unqualified person can result in a serious accident.

When a hydraulic crane is maintained and used properly it can be a safe, highly productive piece of equipment, but if not used properly, it can be dangerous.

Think Safety – You, the operator, are in charge of an important piece of equipment. It is very important that you know what it can do. It is also important that you know what it should not do. No set of instructions can anticipate all of the situations you will encounter. The rules given here cover the general usage, and some of the more common specific cases. If conditions arise not covered by these rules, contact your Link-Belt Distributor. A phone call could save someone's life.



WARNING

Do not lift, suspend, swing or lower loads or attachments over anyone. Do not allow anyone to ride on any part of load or attachment.

SAFETY INSTRUCTIONS

Construction equipment can be dangerous if improperly operated or maintained. This crane should be operated and maintained only by trained and experienced people who have read, understood, and complied with the Operator's Manual.

Before leaving operator's position, lower load to the ground.

Do not use swing brake for swing lock.

When facing over rear some functions will be reversed relative to operator.

Raise the crane on outriggers, or block the wheels, and shutdown the engine before working on the crane. Replace all guards or panels before operating the crane.

Do not deface or remove this label from the crane.

Figure 1-2
Read and understand all points covered in this Operator's Manual before operating the crane.

Operator's Manual

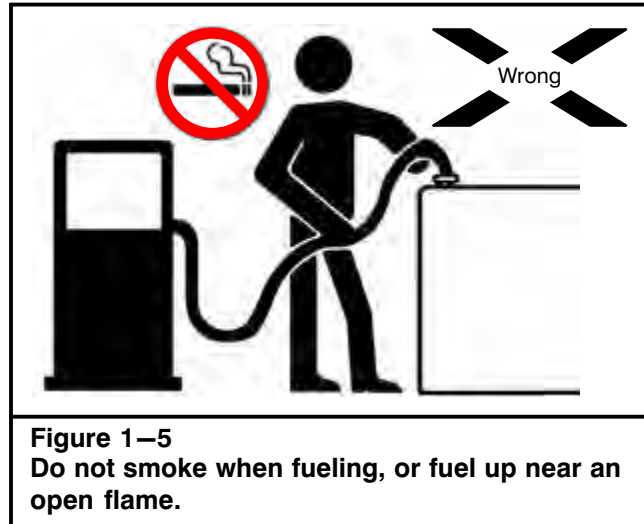
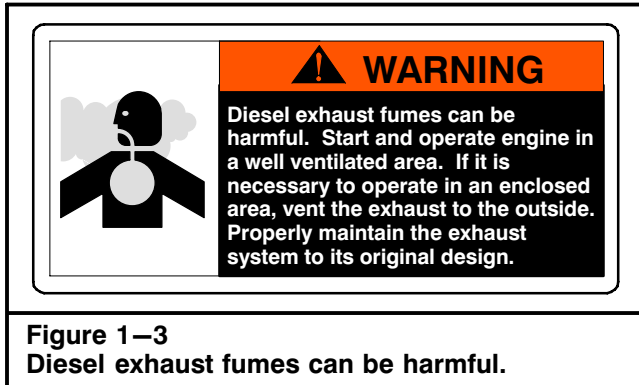

General Safety Rules

The following is a list of safety rules which should be followed during all crane operations.

Operator Awareness

1. Read this Operator's Manual and heed it. The manual contains important information.
2. An operator must not eat, read, or otherwise divert his attention while operating a crane. Remember—operating is a full-time job.
3. Start and operate the engine in a well ventilated area. Diesel exhaust fumes can be harmful. If it is necessary to operate in an enclosed area, vent the exhaust to the outside. Properly maintain the exhaust system to its original design.
4. Don't smoke when fueling, or fuel up near an open flame. Keep the nozzle in contact with the filler neck to prevent static electric sparks. Shutdown the engine when fueling.
5. Keep fingers, feet, and clothing away from sheaves, drums, and wire ropes unless the crane is shutdown and everyone knows what you are doing. Do not place a hand on wire ropes when climbing on the crane. A sudden movement could pull you into the drums or sheaves.
6. Keep your shoes clean. Before entering the operator's cab, wipe clean any mud, gravel, snow, ice, moisture, or grease from your shoes. Slippery shoes could cause momentary loss of control of crucial foot operated controls.
7. Keep all walking surfaces (steps, ladders, platforms, etc.) and non-skid materials on the crane clean. Non-skid materials are placed on the crane to assist operators and service personnel with safe access/egress to/from the crane and to/from adjustment and inspection areas. Do not allow non-skid materials to become contaminated with mud, snow, ice, oil, paint, wax, etc. Any contamination can cause the non-skid materials to become slick, reducing their effectiveness for safety while walking on the crane. If any non-skid materials become ineffective due to wear, age, or destroyed in any way, they must be replaced.
8. To prevent movement of individual boom sections, shutdown the engine and ensure that the operator has properly vacated the operator's cab before putting hands or tools inside the boom. Unexpected movement of the boom sections could sever fingers, hands, arms, etc.
9. The operator, supervisor, or person in charge of the load must observe the following rules:
 - a. Loads must be well secured before lifting. Ensure that the rigging cannot slip off or pull away from the load, or get out of position on the load. Use a three-point sling if necessary to keep the load from rolling or turning over.
 - b. Chains and slings must be of adequate size, in good condition, and not twisted around each other.

Operator's Manual

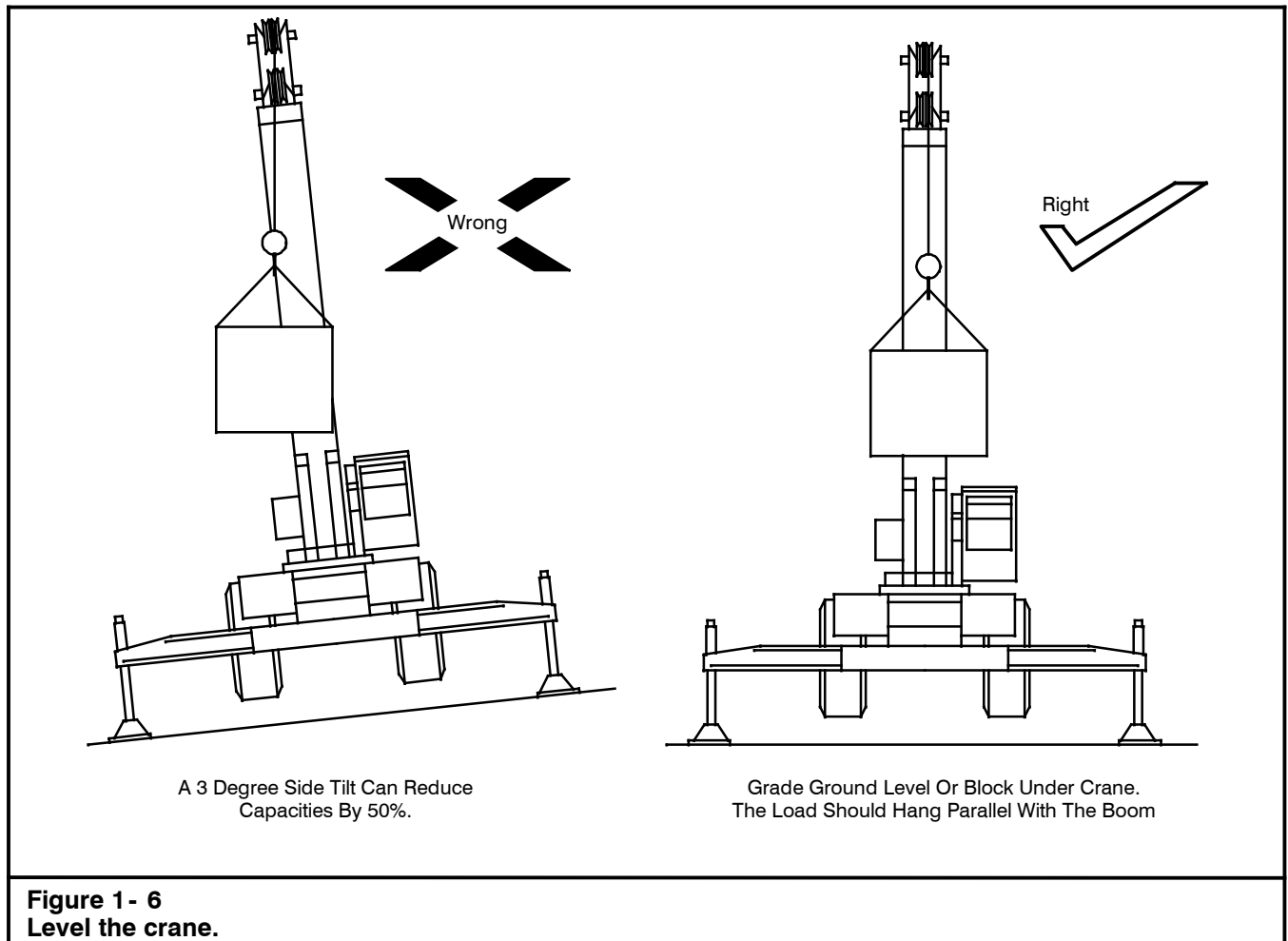

- c. The load must not catch on an obstruction when lifting or swinging. Ensure the load, winch wire rope(s), or any other parts of the crane do not snag or strike any obstruction.
- d. Do not allow the load to rotate out of control. Personal injury to ground personnel, load damage, crane damage, or damage to anti-two block system may occur.
- e. When hoisting with single part line, especially in long falls applications, the design of wire rope and hook ball is crucial to minimize the potential for uncontrolled wire rope and/or load rotation. Rotation-resistant category 1 wire rope is recommended for single part of line applications. See Wire Rope Capacity Chart in the Crane Rating Manual for the specific types of rotation-resistant category 1 wire rope recommended for the crane.
- f. Avoid sudden starts and stops. Lift carefully, swing gently, brake smoothly, lower and set loads carefully. Jerking the load, swinging and engaging swing brake roughly, and lowering the load rapidly and slamming on brakes, will put shock loadings and possible side loadings on the boom. Unnecessary abuse labels the operator as a beginner. Be a professional.
- g. Do not wrap the winch wire rope around the load. Do not use discarded, worn, or damaged wire ropes for slings. They may fail and drop the load.
- h. The crane must be level on a firm supporting surface before making a lift. Use the bubble level or level indicator display to level the crane. Check its accuracy frequently with a carpenter's level. Remember, a three degree side tilt can reduce capacities by 50% or more.
- i. If working at night, ensure adequate lighting is provided so the operator and all other workers can see all movements of the crane, attachment, and load.

Operator's Manual

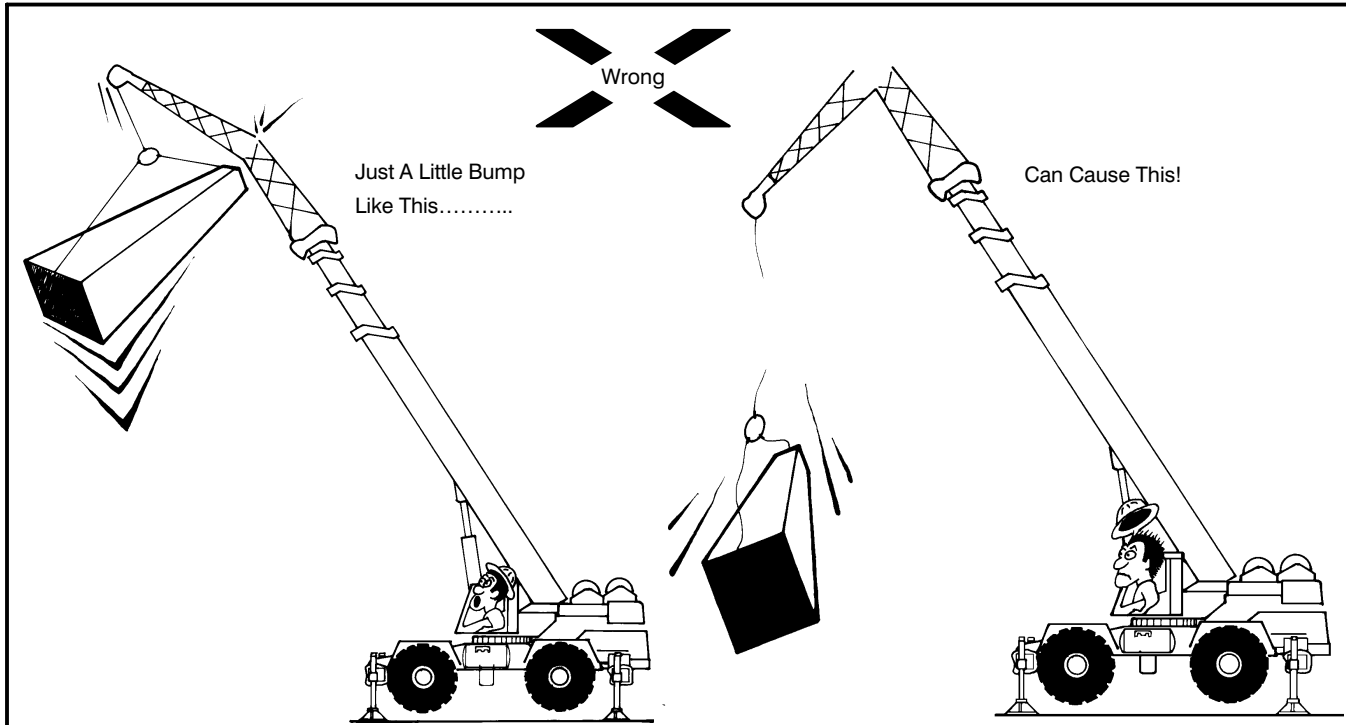

Figure 1-7
Do not let the load hit the boom or fly.

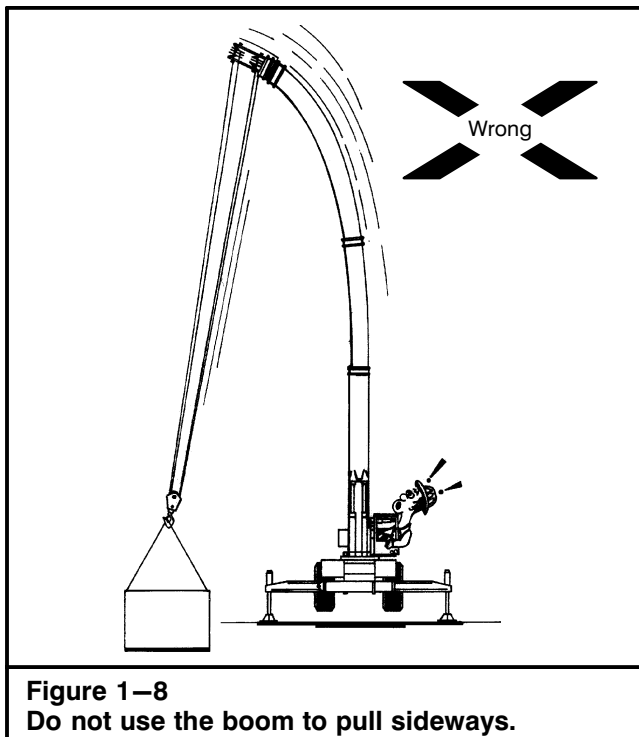

Figure 1-8
Do not use the boom to pull sideways.

10. Operate the crane from the operator's seat only. Operating the crane from any other position, such as reaching in a window, constitutes a safety hazard.

11. Don't let the load or bucket hit the boom or fly. Don't let the boom or attachment rest on, or hit, a building or any other object. A dent or other damage could result, which will weaken the boom or attachment. If there is major damage, the attachment could collapse. If a lattice or diagonal bracing member on the fly is broken, cracked, or bent, contact your Link-Belt Distributor for repair procedures. If the boom or fly is struck, or damaged by anything, STOP. The loading on a boom or attachments increases as they are lowered, therefore their suspension systems could collapse during lowering. Use another crane to lower a damaged boom or attachment.
12. Watch the load or a signal person at all times. A suspended load must have your undivided attention.
13. Don't pull sideways on the boom or fly, not even a little. Lift straight up on every load. Moving trucks, rail cars, barges, or anything else pulling sideways on the winch wire rope could buckle the boom or fly. It could also damage the swing mechanism. Pulling sideways on a boom or fly can overturn the crane.
14. Heat from the sun only on one side of the boom may cause a temperature differential between the sides of the boom. The thermal effects may cause boom distortion (the boom to "deflect" to one side) creating a side load on the boom and/or fly. Side loading is dangerous and shall be avoided.

Operator's Manual

15. Do not “two block” (pull the hook block, hook ball, and/or the load into the head machinery) as this can cause winch wire rope and sheave breakage resulting in an accident.
16. After slack winch wire rope operation, ensure the winch wire rope is properly seated in sheaves and on drums before continuing to operate. Use a stick or mallet to set the winch wire rope, not your hands.
17. Do not lower the load beyond the point where less than three full wraps of winch wire rope are left on the drum. This condition could occur when lowering a load beyond ground level. If all the winch wire rope runs off the drum, the load will jerk which could break the winch wire rope.
18. Ensure there is a safety latch on the hook, and that it works properly. Without a latch, it is possible for slings or chains to come off the hook, allowing the load to fall.
19. Don't alter any part of the crane. Additions to or changes in any part of the equipment can create loadings for which the crane was not designed. Such changes may seriously affect the usable capacities and make all capacities in the Crane Rating Manual invalid. Alterations can dangerously overload or weaken critical parts and may cause disastrous failure.
20. Do not exceed the rated capacities of the crane under any circumstances. While a crane has more stability when lifting over a corner (as compared to straight over the side) the crane capacity is not increased. Anytime the load exceeds the rated capacities listed in the Crane Rating Manual, the crane is overloaded. Overloads can damage the crane and such damage could cause failure and accidents.
21. When operating on outriggers, all beams must be equally extended; all fully retracted, all intermediate extended or all fully extended. Jacks must be extended so all tires are clear of the ground, and the crane must be level. Ensure that pontoons are set on firm surface, adequate to support the blocking, pontoon, crane and load without settling, slipping or collapsing. Blocking or matting under pontoons must form a smooth level surface under the entire pontoon. Do not block under outrigger beams inside the pontoons as this reduces stability. Blocking must be under pontoons only. Remember—there are tremendous loadings on pontoons and blocking – the weight of the entire crane plus any load.

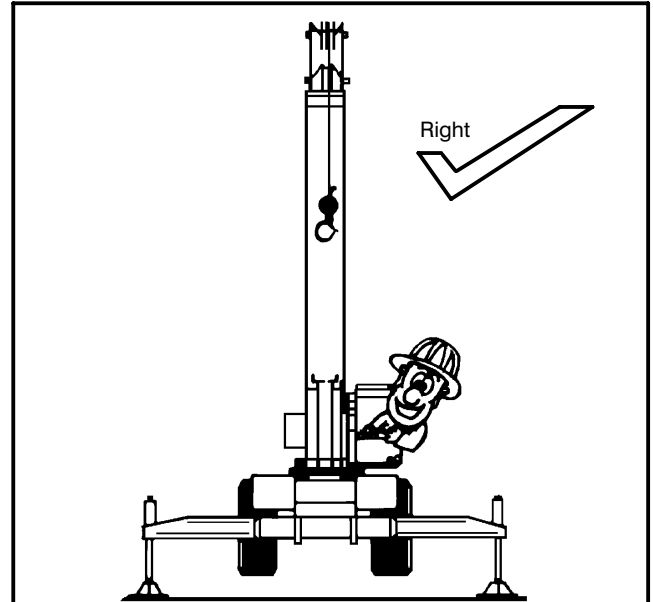
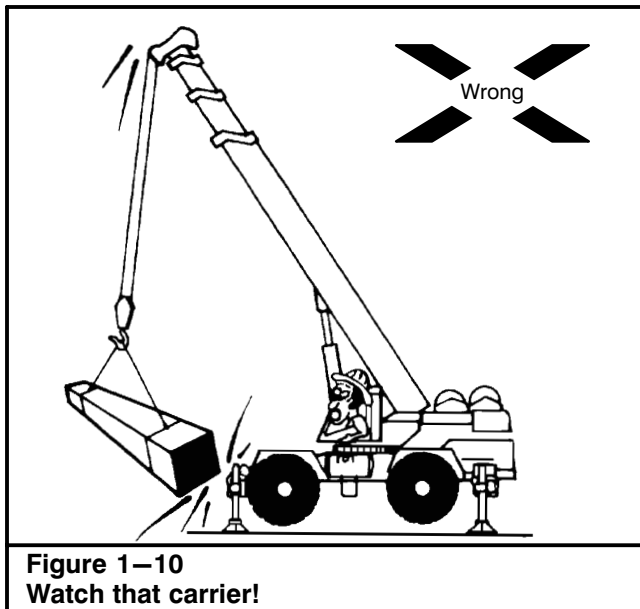

Figure 1—9
Crane level, all beams extended equally (all fully extended, intermediate extended, or fully retracted) and tires clear of the ground.

When blocking or matting under pontoons, ensure that each pontoon is supported fully – no unsupported pontoon area is permissible. Ensure pontoons are on a smooth surface. Rough surface, rocks, etc., under pontoons will cause unequal loadings, and can puncture them, causing them to collapse.

Capacities are based on all outriggers being equally extended: all fully retracted, all intermediate extended or all fully extended. Working on outriggers that are not equally extended will reduce capacities and crane stability considerably and could cause an accident. Do not make any lifts while on outriggers without the outrigger beams equally extended.

Operator's Manual



22. When operating with the boom at a high angle, use care not to let the load hit the carrier.
23. Cold weather operation requires some special attention by the operator to allow for changes in everyday routines:
 - a. Clean the crane, especially the boom, of accumulated amounts of ice or snow. Operating the crane with an ice covered boom is dangerous. The added weight of the ice or snow can drastically reduce the capacity of the crane. Also, falling ice may pose danger for ground personnel.
 - b. Clean all snow and ice from steps, ladders, platforms, etc. to eliminate slippery walking surfaces.
 - c. If cold weather starting aids are provided on the crane, use them. The use of aerosol starting sprays can be dangerous if the manufacturer's directions are not closely followed.

- d. Pay close attention to the gauges in the operator's cab when starting the engine. Normal "warm up" times will be longer. Ensure pressures and temperatures are within normal ranges before beginning operations.
 - e. Always handle flammable materials according to the manufacturer's instructions. Propane, diesel, or other fuel for auxiliary heaters can be dangerous if not properly handled. Do not store such fuels on the crane.
 - f. Use caution when lifting any load during freezing weather, as it may be frozen to the ground or the supporting surface. The added tension, to break the load free, could cause an unexpected overload situation. Also, when the load does finally break loose it could create an erratic motion causing damage or injury.
 - g. At the end of the work shift, park the crane where it will not freeze to the ground. Major damage to the drive mechanism could occur while trying to free the crane from a frozen surface.
24. Before attempting to move the carrier, ensure there is enough oil pressure to operate the brakes. Always check the brake operation before traveling the crane.
 25. Brake firmly in one application. Avoid fanning the brakes. This could exhaust oil pressure so fast that the pump may not supply enough oil.
 26. Do not coast downhill with the transmission in neutral. It makes control of the crane more difficult and dangerous.
 27. Shift the transmission to neutral before operating the crane. Crane operation can cause movement which can damage the transmission or drive line. When parking, shift to neutral and engage the park brake. Block wheels if not on a level surface.

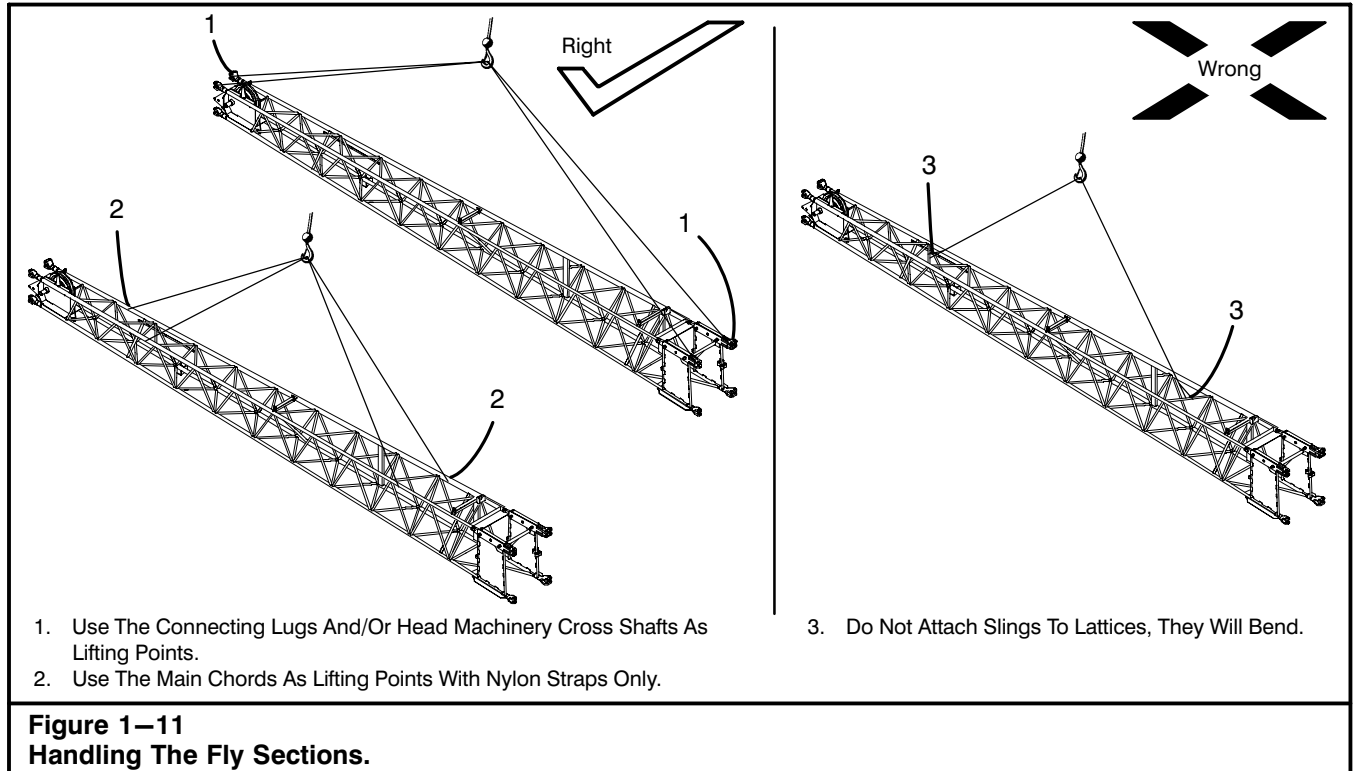

28. Use care handling the fly when loading, transporting, and unloading. Damage that occurs during these operations can go undetected and could result in failure of the attachment, once subjected to loading. Do not attach slings to the lattices, when lifting the fly, as they will bend. It is recommended that the connecting lugs and/or head machinery cross shaft be used as the lifting points. However, it is permissible to attach nylon straps around main chords to handle the fly.
29. Block under and between the fly sections when loading them on a transport vehicle. When securing the fly to a transport vehicle, it is best to use synthetic webs or slings. If using wire rope slings, pad the fly to protect it from damage. Do not overtighten the tie downs or the fly may be damaged. Do not use chain tie downs, as they may dent and damage the fly section.

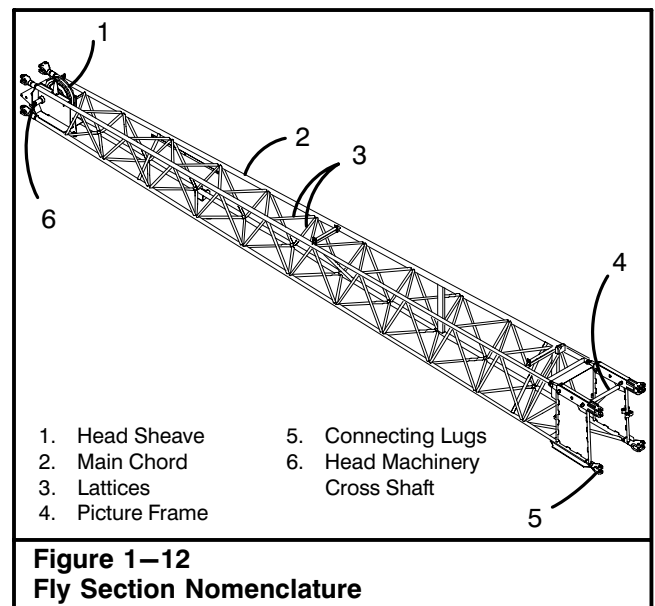

30. Thoroughly inspect all the elements of the fly section before installing it on the crane. Check each main chord, picture frame, diagonal, lattice, and connecting lug for bends, dents, and cracked or corroded welds. Picture frames must be square. Do not use any fly section that is even slightly damaged. Contact your Link-Belt Distributor for the proper repair procedures.

Operator's Manual

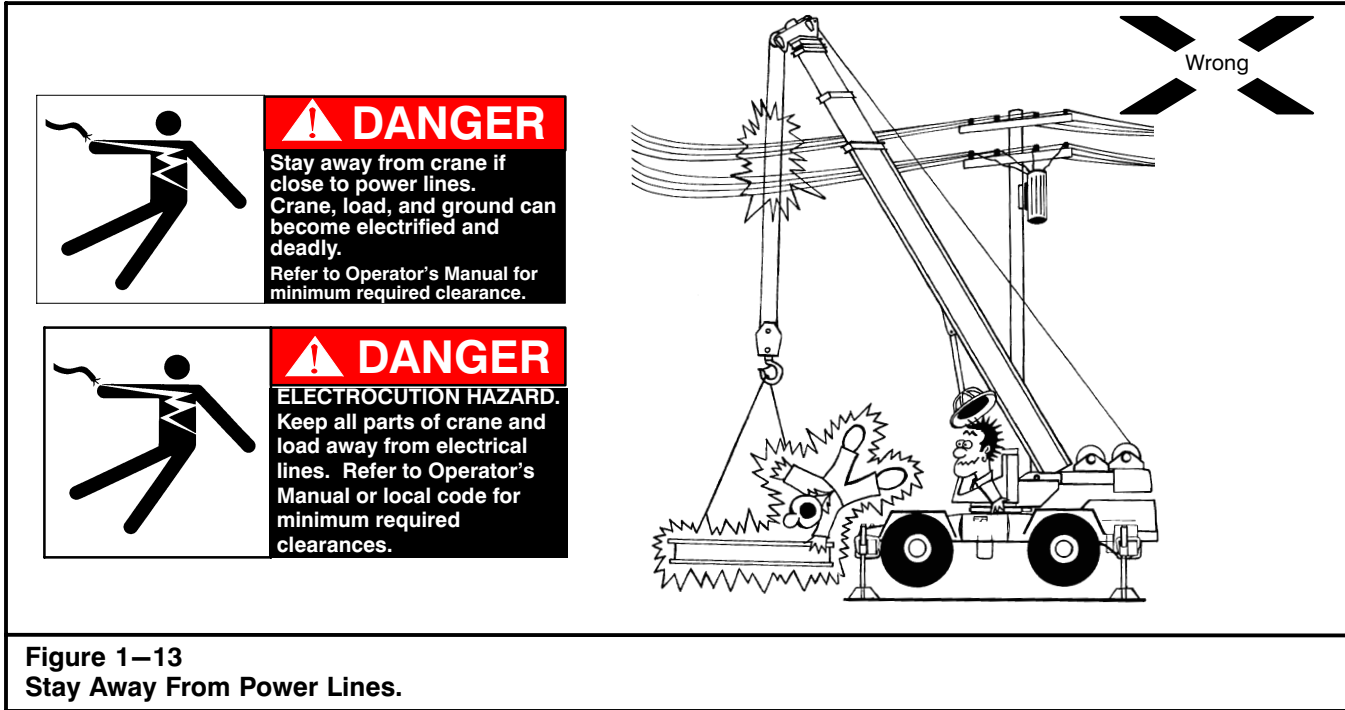

Figure 1–13
Stay Away From Power Lines.

| Minimum Clearance When Operating Near High Voltage Power Lines Or During Crane Assembly/Disassembly | |
|--|---|
| Normal Voltage, kV (Phase to Phase) | Minimum Required Clearance, ft (m) See Note 1 |
| To 200 | 15 (4.57) |
| Over 200 To 350 | 20 (6.10) |
| Over 350 To 500 | 25 (7.62) |
| Over 500 To 750 | 35 (10.67) |
| Over 750 To 1000 | 45 (13.72) |
| Over 1000 | As established by the power line owner/operator or registered professional engineer who is a qualified person with respect to electrical power transmission and distribution. |
| Minimum Clearance When Traveling With No Load | |
| To 345 | 15 (4.57) |
| Over 345 To 750 | 16 (4.87) |
| Over 750 To 1000 | 20 (6.10) |
| Over 1000 | As established by the power line owner/operator or registered professional engineer who is a qualified person with respect to electrical power transmission and distribution. |
| Note 1: Maintain 50 ft (15.2m) minimum clearance from power lines if voltage is unknown. If unknown but yet known to be less than 350 kV, maintain 20 ft (6.1m) minimum clearance. | |
| Note 2: Environmental conditions such as wind, fog, smoke, or precipitation may require increased clearances. | |
| High Voltage Power Line Clearance Chart | |

Electrical Dangers

1. All Electrical Power Lines Are Dangerous. Contact with them, whether insulated or not, can cause death or injury. When operating near power lines, the best rule is to have the power company turn off the power and ground the lines. However, in some cases, the operator may be unable to have the power turned off. Follow these rules whether the power is turned off or not. Follow all requirements per OSHA regulations 1926.1407 through 1926.1411 as applicable while assembling, disassembling, operating, or traveling the crane in the vicinity of any power lines.
 - a. Be alert. You are working around conditions which can cause death.
 - b. Keep all parts of the crane – winch wire rope(s), hook block, hook ball, and load – at least the distance from the power line as specified in the “High Voltage Power Line Clearance Chart”, or such distance as required by any other state or local requirements.
 - c. Assume that every line is “Hot”.
 - d. Do not perform any crane assembly/disassembly under any energized power line.
 - e. Overhead lines can move when the wind blows against them. Allow for this when determining safe operating distances.

Operator's Manual

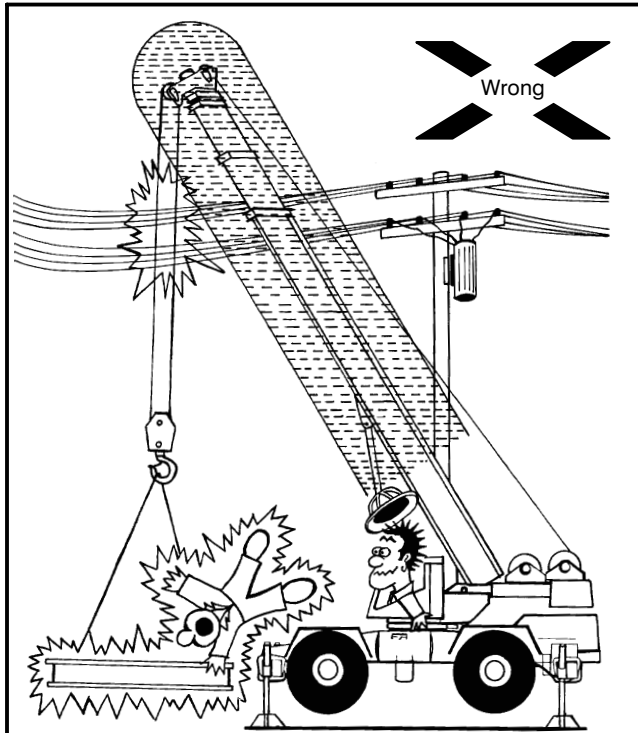

Shaded area shows "sensitivity zone" with full boom length sensor used. Contact can be made outside this zone by the winch wire rope(s), cab, etc. In such cases the warning will not sound until contact is made, and the crane is electrified and deadly.

Figure 1-14
Crane equipped with proximity warning device on the entire boom.

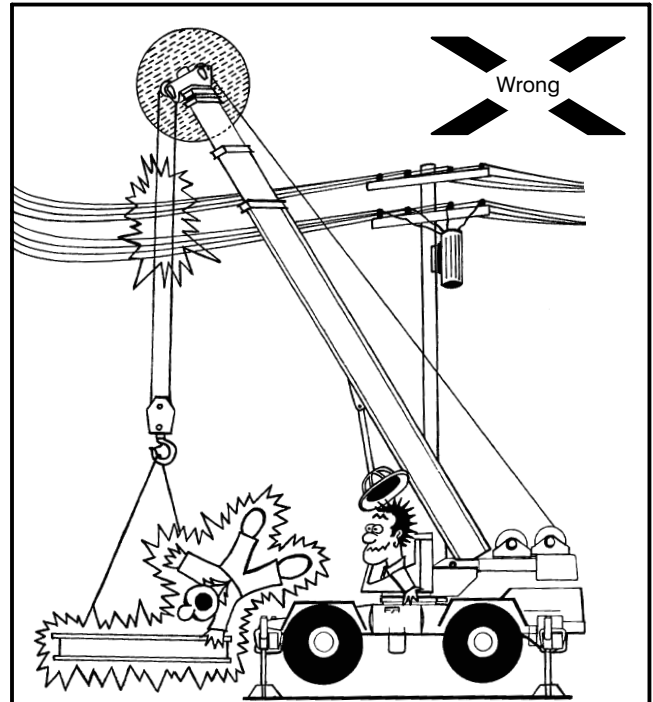

Shaded area shows "sensitivity zone" with the probe near the boom peak. Contact can be made outside this zone by the winch wire rope(s), cab, etc. In such cases the warning will not sound until contact is made, and the crane is electrified and deadly.

Figure 1-15
Crane equipped with proximity warning device on boom tip.

- f. Appoint a reliable person equipped with a loud signal (whistle or horn) to warn the operator when any part of the crane is working around the power line. This person should have no other duties while the crane is working around the power line.
- g. Warn all personnel of the potential danger. Don't allow unnecessary persons in the area. Don't allow anyone to lean against or touch the crane. Don't allow workers or load handlers to hold load, load lines, or rigging gear unless absolutely necessary. In these cases, use dry hemp or plastic ropes as tether lines. Make certain everyone stays a minimum distance away from the load as specified in the "High Voltage Power Line Clearance Chart", or such distance as required by any other state or local requirements.
- h. The use of boom point guards, proximity devices, insulated hooks or swing limit stops do not assure safety. Even if codes or regulations require the use of such devices, you must follow rules listed here. If you do not follow them, the result could be serious injury or death.
- i. Grounding the crane can increase the danger. Poor grounding such as a pipe driven into the ground, will give little or no protection. In addition, a grounded crane may strike an arc so heavy that a live line may be burned down. This could cause the crane and the area around it to be electrified.
- j. When operating near radio or T.V. transmitting stations, high voltage can be induced in metal parts of the crane, or in the load. This can occur even if the crane is some distance from the transmitter or antenna. Painful, dangerous shocks could occur. Contact trained electronic personnel before operating the crane to determine how to avoid electrical hazards.

Operator's Manual

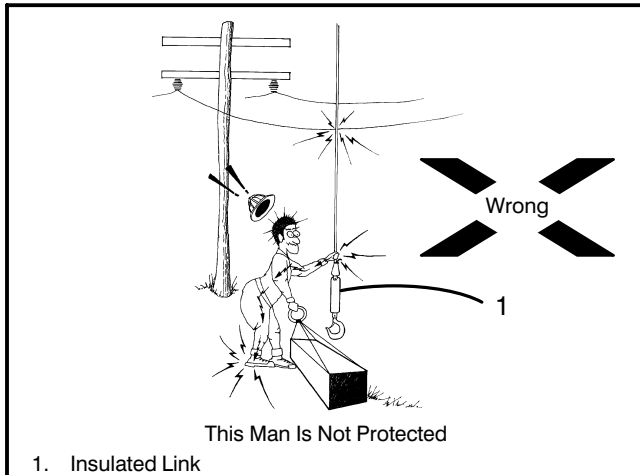

Figure 1-16
Crane equipped with insulated link.

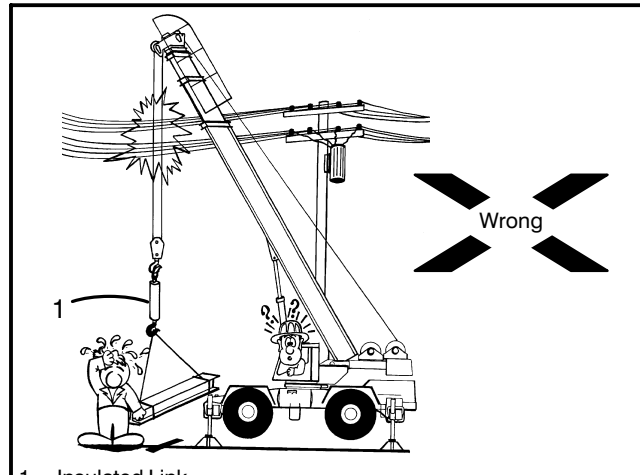

Figure 1-17
Crane equipped with insulated link and boom point guard.

2. What do you do if a power line is touched by a crane or load?

- a. Remain calm – think – a mistake can kill someone.
- b. Warn all personnel to keep clear.
- c. If crane will still operate, try to move it away from contact. You, the operator are reasonably safe in the cab unless the crane is on fire or an arc is cutting through the cab.
- d. Move away from contact in the reverse direction to that which caused the contact. Example: If you swing left to the wire, swing to the right to break contact. Remember – once an arc has been struck, it will stretch out much farther than you think before it breaks. Keep moving until the arc has been broken.
- e. When the arc breaks, continue moving until you are at least the minimum distance away as specified in the “High Voltage Power Line Clearance Chart”, or such distance as required by any other state or local requirements. Stop the crane. Thoroughly inspect crane and repair any damage before further use. Contact a Link-Belt Distributor and request a “Crane Inspection After Contacting Power Line” form which lists necessary inspection items.
- f. If you cannot disengage from the electrical line, and the crane is not on fire or no arc is cutting through the cab, stay in your seat until power line can be turned off.
- g. If you must leave the crane, don't step off. Leap from the crane as far as you can, landing with feet together, then hop away from the crane with feet together, or shuffle feet to keep them close together. This could help prevent personal injury.

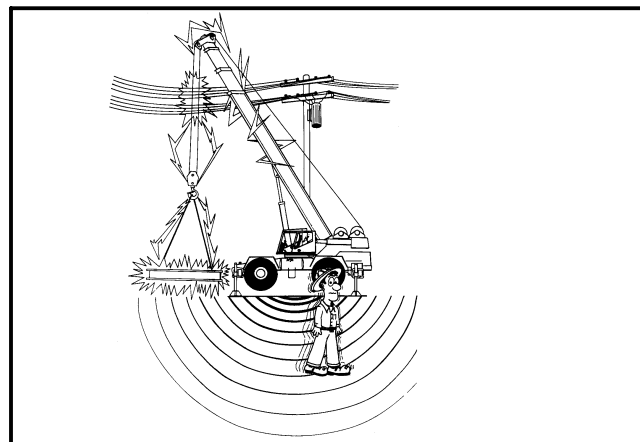

Figure 1-18
If you must leave the crane, do not step off. Leap as far as you can with feet together and hop or shuffle away from the crane.

3. When using a magnet:

- a. Lifting magnet generators produce voltage in excess of 200 volts and present an electrical shock hazard. Only trained personnel should work on the magnet, controller, or wiring. Don't open the controller door with the generator running.
- b. Do not let workmen touch magnet or load.
- c. Do not let workmen get between magnet and a metal object.
- d. If necessary to position a load, use a dry, wooden stick.
- e. Open magnet disconnect switch at magnet control panel before connecting or disconnecting leads.

Operator's Manual

Radio Frequency Or Electro Magnetic Interference (RFI Or EMI)

Certain areas may contain high Radio Frequency Or Electro Magnetic Interference (RFI or EMI). In these areas the boom can act like an antenna and produce an electrical current that may cause electrical shocks and/or the crane to malfunction. If operating in an area where these conditions may exist, test the crane or have the area tested for the magnitude of this interference before operating the crane. Operation may not be possible or boom length may be limited. Comply with all local, state, and federal laws when operating in high RFI/EMI areas.

Protective Equipment

1. Always replace protective guards and panels before operating the crane.
2. Always wear hard hats, safety glasses, steel toe shoes, hearing protection, and any other safety equipment required by local job conditions, OSHA, or any other requirements of applicable codes.
3. Always wear safety glasses when drilling, grinding or hammering. Flying chips could injure the eyes.
4. Always wear a mask to prevent breathing any dust, smoke, fumes, etc. while cleaning, drilling, welding, grinding, sanding, etc. on any part of the crane. Breathing dust, smoke, fumes, etc. can be very hazardous.
5. When operating a crane equipped with any form of load indicating mechanism, overload warning system, or any automatic safety device, remember that such devices cannot replace the skill and judgment of a good operator. For instance, such devices cannot tell when a crane is setting on a supporting surface that will give away, that too few parts of line are being used to lift a load, cannot correct for the effects of wind, warn that the device may be improperly adjusted, correct for side pulls on the boom, or for many conditions which could occur and create hazards. It requires all the skill, experience, judgment, and safety consciousness that a good operator can develop to attain safe operation. Many safety devices can assist the operator in performing their duties, but they should not rely on them to keep them out of trouble.

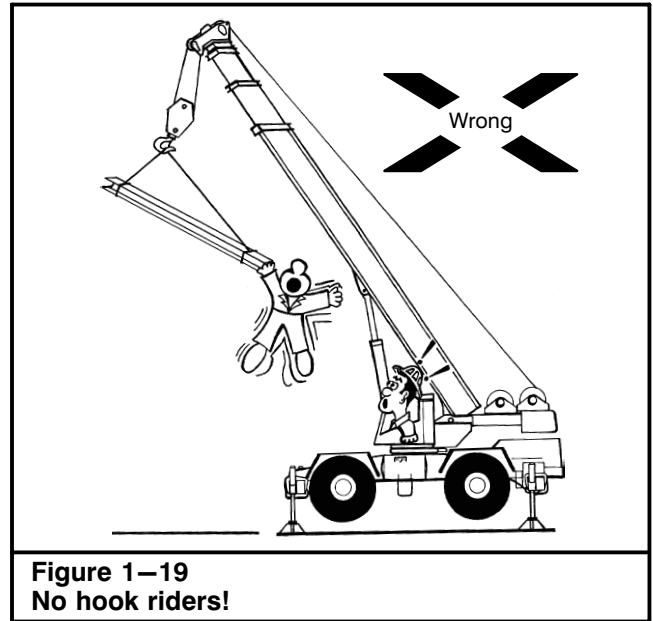

6. The crane is equipped with a fire extinguisher in the operator's cab. Ensure all personnel know that one is available and where it is located. It must be kept in the crane at all times (except when needed). Instruct all operating and maintenance personnel in proper use of the extinguisher. Check periodically to ensure it is fully charged and in working order. Replace immediately if required.
7. Do not tamper with safety devices. Keep them in good repair and properly adjusted. They were put on the crane for your protection.

Signal Persons And Bystanders

1. Don't allow crane boom or loads to pass over people, or endanger their safety. Remove all loose objects from load. All unnecessary personnel should leave the immediate area when crane is operating.
2. Do not allow anyone to ride on the hook block, hook ball, or any part of the load or attachment for construction work or recreational activities. (This applies to recreational activities such as "bungee jumping" or "bungee cord jumping".) Cranes are intended to lift objects, not people. They are not elevators.
3. Do not carry passengers! There is only one seat and it is for the operator. Do not allow personnel to ride on the carrier deck during operation or while traveling the crane. A fall from the crane can cause death or serious injury.

Operator's Manual

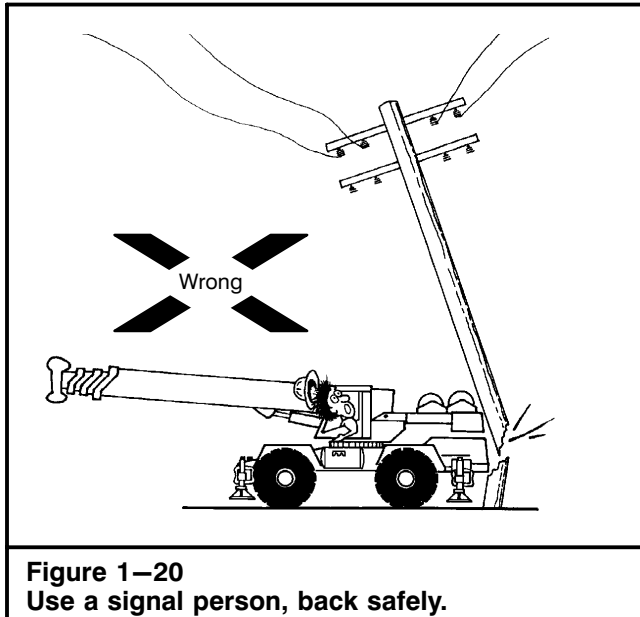

4. Always look before you back up and post a signal person to guide you. Ensure the back up alarm is working properly. Use the horn as a signal. Use a code such as one beep – stop, two beeps – forward, and three beeps – backward. Ensure everyone on the job site knows the code.
5. Do not make a lift which is not in plain sight without a signal person. This can lead to an accident or crane damage.

Crane Inspections And Adjustments

1. Inspect the crane daily. Do not operate a damaged or poorly maintained crane. Pay particular attention to the clutches, brakes, attachments, and wire ropes. If a component is worn or damaged, replace it before operating.
2. Labels, decals, plates, etc. should be periodically inspected and cleaned as necessary to maintain good legibility for safe viewing. If any instruction, caution, warning, or danger labels, decals, or plates become lost, damaged, or unreadable, they must be replaced.
3. When performing repetitive lift applications, especially at or near maximum strength limited capacities, an inspection of the major structural areas of the crane, for cracks or other damage, should be conducted on a regular basis. (A non-destructive test such as magnetic particle or dye penetrant may even be considered.) Along with inspection for cracks and damage, frequently check the critically loaded fasteners, such as the turntable bearing mounting capscrews, to ensure they have not been stretched. Not only does frequent inspection promote safety, but it is also much easier and less expensive to perform a repair when a crack is

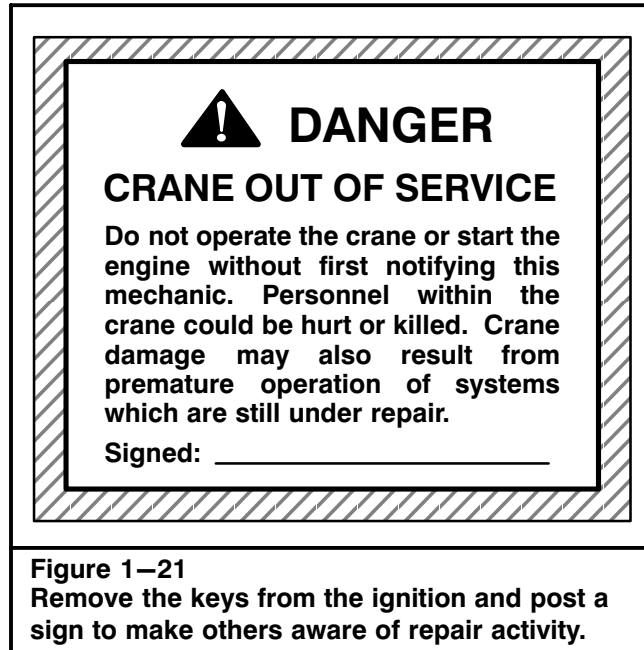

- small, before it has a chance to traverse through a structural member. Any sign of cracks or damage must be repaired before continuing operations. Contact your Link-Belt Distributor for repairs.
4. When performing maintenance on the crane, do the following:
 - a. Fully retract the boom. Lower the boom to the limit of the boom hoist cylinders.
 - b. Shutdown the engine, disengage the main pump, (if equipped) and work all control levers back and forth to relieve pressure and relax the attachment.
 - c. If the above instructions cannot be followed, block securely under the attachment so it cannot move.
 - d. Bleed any precharge off the hydraulic reservoir before opening it or disconnecting a line.
 - e. Hydraulic oil becomes hot during operation. In some cases it becomes hot enough to cause severe burns. Be careful not to let hydraulic oil come in contact with skin.
 - f. Post warning signs in cab so no one will try to start the engine. Do not adjust, maintain, or repair a crane while it is in operation without visual and/or verbal contact to ensure the safety of service personnel.
5. When making repairs, which require welding, use proper welding procedures. Also the following precautions must be taken:
 - a. All paint and acoustical material in the area should be removed to prevent burning them. The smoke and fumes from the burning paint and/or acoustical material can be very hazardous.

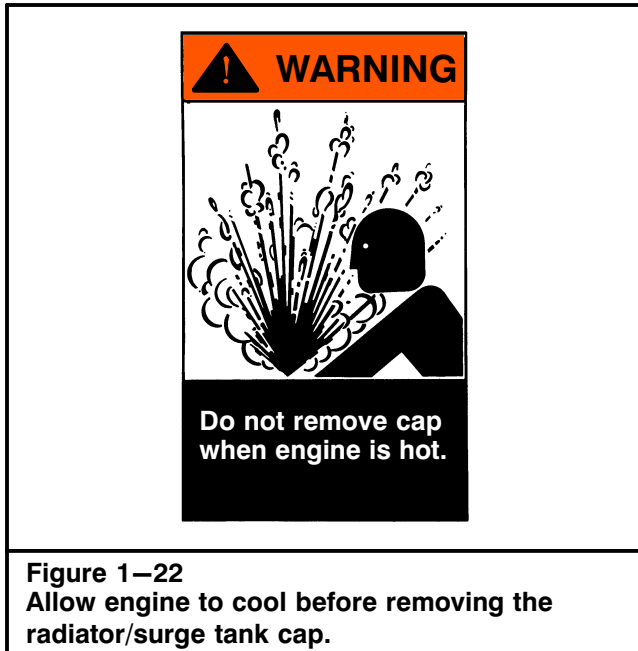

- b. Turn the battery disconnect switches to the "OFF" position to protect any electronic equipment on the crane which may be effected by electric arc welding. Contact a Link-Belt Distributor for proper procedures.
 - c. The welding ground cable should be attached to the portion of the crane being welded. If welding on the upper, ground on the upper. If welding on the carrier ground on the carrier. Failure to take this precaution may result in electrical arcs in the turntable bearing.
 - d. The welding ground cable should always be connected as close as possible to the area being welded. This minimizes the distance that electricity must travel.
 - e. Disconnect computers and other electronic equipment (such as rated capacity limiters and engine computers) to prevent damage. Contact your Link-Belt Distributor for proper procedures.
 - f. If crane is equipped with a 12V to 24V converter in the power panel, remove the fuses before welding.
 - g. Remove all flammables from the proximity of the welding area.
6. Keep the crane clean, in good repair, and in proper adjustment. Oil or grease on the decks may cause falls. Improper adjustments can lead to crane damage, load dropping, or other malfunctions.

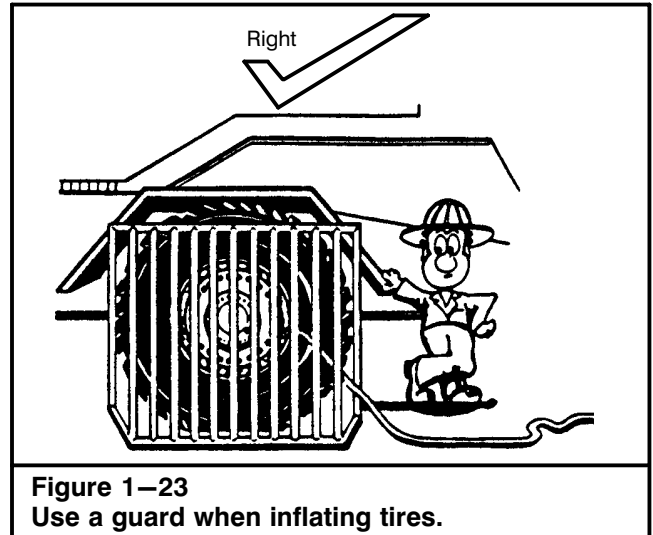

7. Keep all walking surfaces (steps, ladders, platforms, etc.) and non-skid materials on the crane clean. Non-skid materials are placed on the crane to assist operators and service personnel with safe access/egress to/from the crane and to/from adjustment and inspection areas. Do not allow non-skid materials to become contaminated with mud, snow, ice, oil, paint, wax, etc. Any contamination can cause the non-skid materials to become slick, reducing their effectiveness for safety while walking on the crane. If any non-skid materials become ineffective due to wear, age, or destroyed in any way, they must be replaced.
8. Use proper fall protection such as a fall arrest system as required by any applicable codes when working at elevated heights. Falls can lead to severe personal injuries and/or death.
9. Use extreme caution when removing radiator/surge tank caps, hydraulic pressure caps, etc. They can fly off and hit you, or you could be burned by hot oil, water, or steam.
10. Check tires daily for correct pressure. Do not stand in front of a tire when inflating it. The lock ring can fly off and injure you. Use a clip on inflator, and stand aside. Use a guard in front of the tire.
11. Test the automatic winch brake by raising the load a few inches (*centimeters*) and holding. It should hold without slipping. It takes more braking power to hold a load in the air when the drum is full of wire rope than when it is a few inches (*centimeters*) above the ground with only a few wraps on the drum.

Operator's Manual

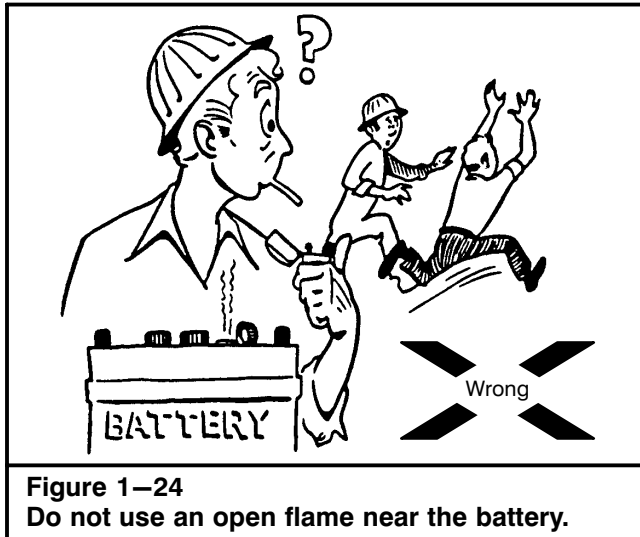

Figure 1-24
Do not use an open flame near the battery.

12. Always reduce pressure in hydraulic system to zero before working on any part of the system.
13. Use extreme care when working with circuits with accumulators. Check that hydraulic pressure is relieved before opening the circuit for repairs.
14. When setting pressures, never exceed the manufacturer's ratings. Always follow instructions exactly. Over pressurization can cause hydraulic component damage or failure of mechanical parts on the crane. Either of the above can lead to an accident.



WARNING

Battery posts, terminals, and related accessories contain lead and lead compounds. Wash hands after handling.

15. When checking battery fluid level, use a flashlight, not an open flame. If the battery explodes, you can get acid in your eyes, which could cause blindness. Don't check battery charge by shorting across posts. The resulting spark could cause the battery to explode. Check with a tester or hydrometer. Don't smoke near batteries.
16. When using jumper cables to start an engine, connect the negative post to negative post, and positive post to positive post. Always connect the two positive posts first. Then make one negative post connection. Make the final negative connection a safe distance from the battery. It can be made on almost any bare metal spot on the crane. Any spark could cause the battery to explode. Refer to "Jump Starting the Crane" in this Section of this Operator's Manual for the proper procedure.

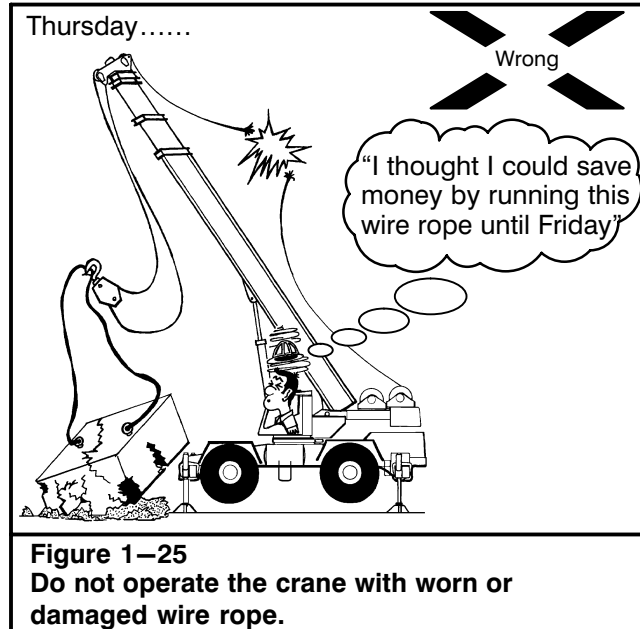

Figure 1-25
Do not operate the crane with worn or damaged wire rope.

Wire Rope

1. Inspect all wire rope thoroughly. OSHA (Occupational Safety And Health Act) regulations state "a thorough inspection of all wire ropes shall be made once a month and a full written, dated, and signed report of the wire rope condition be kept on file where readily available." A visual inspection must also be performed daily. Replace any worn or damaged wire rope. Pay particular attention to winch wire ropes. Check end connections (pins, sockets, wedges, etc.) for wear or damage.
2. Use at least the number or parts of winch wire rope specified on the Wire Rope Capacity chart in the Crane Rating Manual to handle the load. Local codes may require more parts of line than is shown. Check code requirements and use them where applicable.
3. Non-rotating, rotation resistant, or spin resistant wire ropes are recommended for single part of line applications. This is of utmost importance for long fall hoist line applications. Only if certain criteria are met may a swivel hook ball be used with rotation resistant rope. Refer to "Hook Ball Usage With Rotation Resistant Wire Rope" in Section 5 of this Operator's Manual.
4. A swivel hook ball may be used with rotation resistant wire rope only if certain criteria are met. Refer to "Hook Ball Usage With Rotation Resistant Wire Rope" in Section 5 of this Operator's Manual.
5. Do not handle wire rope with bare hands. Always use gloves to prevent possible injury from frayed or damaged spots in the wire rope.

6. Inspect head machinery and hook block often as damaged or deteriorating sheaves can cause undue wear of the wire rope.
7. When reeving wire rope on the crane, do not stand, walk, or climb on the boom or attachment. Use a ladder or similar device to reach necessary areas.

Crane And Area Clearance

1. Know your job site conditions. Familiarize yourself with work site obstructions and other potential hazards in the area which might lead to mishaps. If possible, make any necessary arrangements to eliminate any potential hazards.
2. Erect barricades around the immediate work area to prevent unauthorized personnel from wandering onto the job site.
3. Ensure your work area is clear. Ensure you have proper clearance for the crane, boom, and load. Don't swing, travel, lift, or lower loads, raise or lower jacks, without first making sure no one is in the way. If your vision is obscured, locate a signal person so you can see them, and they can see all areas you can't. Follow their signals. Ensure you and the signal person understand each other's signals. See Hand Signals Chart in this Section of this Operator's Manual. Use the horn to signal or warn. Ensure everyone on the job site understands signals before starting operations.
4. When working inside a building, check overhead clearance to avoid a collision. Check load limits on floors or ramps so as not to crash through.
5. Don't operate close to an overhang or deep ditch. Avoid falling rocks, slides, etc. Don't park crane where a bank can fall on it, or it can fall in an excavation. Don't park where rain can wash out footing.
6. Watch the tailswing of the upper revolving frame and counterweight. Even though the original set-up may have been clear, situations change.
7. Do not store material under or near electrical power sources. Make material handlers aware of the dangers involved with storing material under power lines or in the vicinity of any other hazards.

Weights, Lengths, And Radii

1. Know your load. Don't try to guess or estimate the load. Use a scale or a load indicating system to determine exact weight. Remember the weight you are lifting includes the weight of any lifting slings or gear, the hook block, hook ball, and any other weight on the hook. If lifting off the boom with the fly installed, the weight of the fly and rigging must also be considered as part of the load. The total load weight must never exceed the rated capacity of the crane, as listed in the Crane Rating Manual, for the position, boom length, load radius, and condition of operation being used.

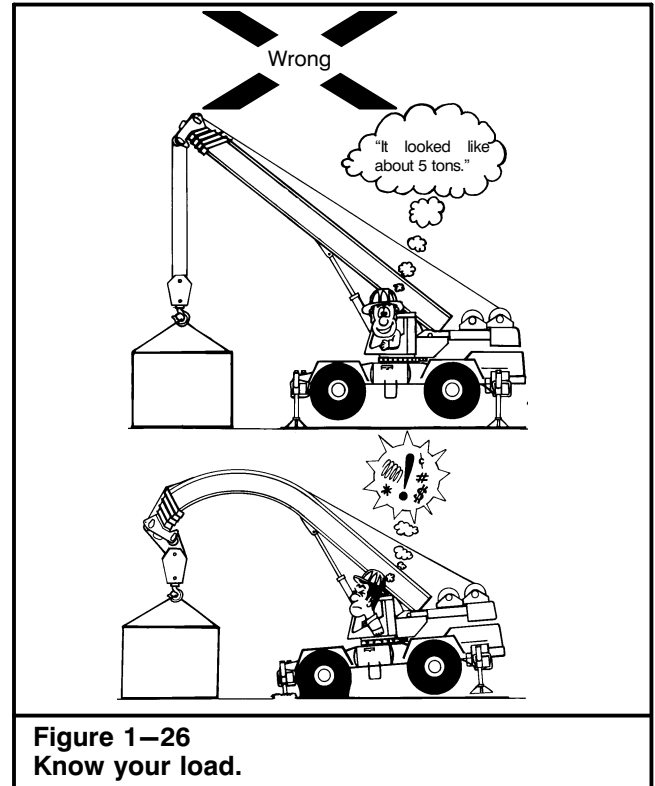

Figure 1-26
Know your load.

Remember – capacity chart ratings in the Crane Rating Manual are based on ideal conditions:

- a. Standing on firm, level surface.
- b. Calm wind.
- c. No side loads or out swing of load.
- d. Good visibility.
- e. Crane in top condition and equipped as when leaving the factory.

When such conditions cannot be attained, loads being handled must be reduced to compensate. The amount loads are reduced depends upon how good or how poor actual operating conditions are. It is a matter of judgment and experience. Some factors which may require reduction of capacities are:

- a. Soft or unpredictable supporting surfaces.
- b. Wind.
- c. Hazardous surroundings.
- d. Inexperienced personnel.
- e. Poor visibility.
- f. Fragile loads.
- g. Crane in poor condition.
- h. Condition and inflation of tires.

Operator's Manual

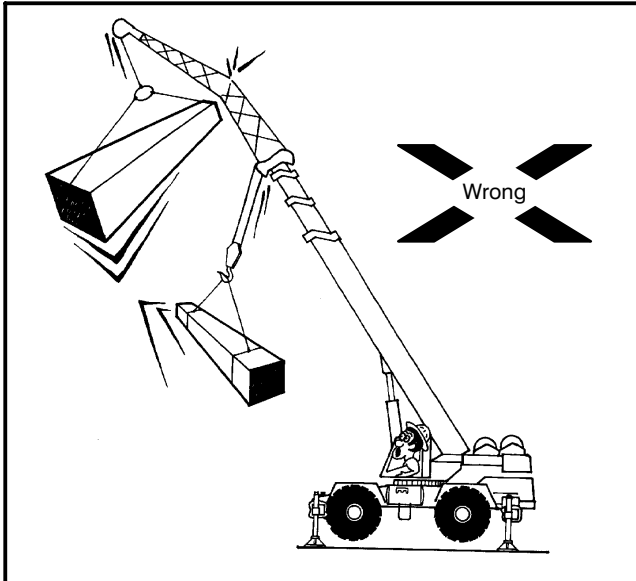

Figure 1–27
Do not lift two loads at the same time.

When in doubt, do not take a chance. Reduce ratings more than you think you need. Avoid working a crane in high winds. If you must work in a wind, reduce capacities as shown in “Wind Speed Restrictions” in the Crane Rating Manual. Wind blowing against the load and the boom produces a side load on the boom and reduces its capacity.

When lifting loads in a wind which have large surface areas, such as building panels, the movement of the load may pose a danger to workmen or building structures. Out swing of a load will increase the load radius, and may overload the crane. This could lead to boom failure or the crane tipping.

2. When operating off the main boom with the fly erected, deductions must be made for its weight. The weight of the fly must be subtracted to obtain a “NET” capacity. Failure to do so could result in an overloading condition and cause boom failure. Refer to the Crane Rating Manual for amounts to be deducted.
3. When operating off the main boom with the auxiliary lifting sheave installed, the weight of the auxiliary lifting sheave must be deducted. Refer to the Crane Rating Manual for amount to be deducted.

SAFETY INSTRUCTIONS

Operation under conditions which exceed listed capacities may result in overturning.

Swinging, extending, or lowering boom to radii where no capacities are listed may result in overturning even without a load.

Figure 1–28
Safety Instruction Label

4. Do not lift two loads at the same time, even if the total load weight is within crane capacity. Loads on the boom and fly at the same time, stress the boom and drastically reduce its ability to handle loads. Your full attention cannot be given to both loads, creating a dangerous situation.
5. Lifts where two or more cranes work together can be hazardous and should be avoided. Such lifts should be made only under the direction of a qualified engineer. If a multiple crane lift is unavoidable, observe the following rules:
 - a. The cranes must be level and setting on firm surfaces.
 - b. The cranes should be the same size and capacity, use the same boom length and be reeved similarly.
 - c. Cranes must be positioned so that each boom point is directly over its load attaching point. The winch lines must be vertical during all phases of the lift.
 - d. The rigging must be placed so each crane lifts a share of the load well within the crane's capacity.
 - e. Ensure that during handling more load is not transferred to any crane than it can handle.
 - f. Don't attempt to travel when making multiple crane lifts.
 - g. Coordinate plans with the other operator before beginning to lift.
 - h. Use only one signal person.
 - i. Use of an operable load and angle indicating system is desirable.

Operator's Manual

6. Some capacities on hydraulic cranes are based on strength of materials. In these cases, overloads will cause something on the crane to break, before it will tip. Do not use signs of tipping as a warning of overload.
7. Don't tie a crane down. Tying a crane down encourages overloading. Crane damage or injury could result.
8. Do not shock load and/or overload the crane at anytime. Shock loading or overloading the crane will reduce the fatigue life of crane components and could result in component failure.
9. When performing repetitive lift applications, especially at or near maximum strength limited capacities, be aware that these applications may reduce component life. These applications include repeated lifting (or lifting and swinging) of near 100% strength limited capacities and repeated lifting maximum moment loads. These applications may fatigue the major structural portions of the crane. Although the crane may not break during these applications, they can reduce the fatigue life and shorten the service life of the crane. To improve the service life, while performing repetitive lift applications, consider reducing the capacities to 70% of maximum strength limited capacities to reduce fatigue cracking. Frequently perform a thorough inspection of all the structural areas of the crane. Any sign of cracks or damage must be repaired before continuing operations. Contact your Link-Belt Distributor for repairs.
10. Always refer to the Crane Rating Manual after changing the arrangement of the attachments for the correct lifting capacities.
11. The boom must be extended in the correct manner before making a lift. The capacities listed in the Crane Rating Manual for this crane are based on the boom sections being extended in accordance with each specific boom mode as described in the Crane Rating Manual.

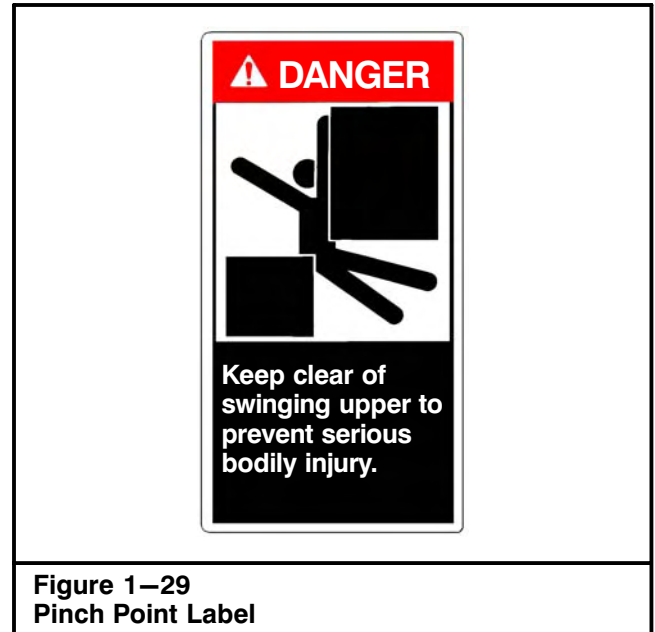

Figure 1–29
Pinch Point Label

Operator's Manual

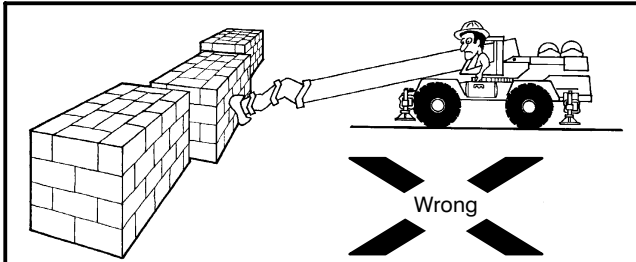

Figure 1-30
Do not push with the boom.

12. Do not use the boom to push or pull. It is not designed for this purpose. Such action can damage the boom and lead to an accident.
13. Know the load radius. Don't guess at it. Determine the load radius by using the boom angle indicator, the boom length indicator, and the Crane Rating Manual, or measure it with a steel tape. Remember – Radius is the horizontal distance from the center-line of rotation of the upper to the center of gravity of the load, when the load is hanging free.
14. Do not operate a hydraulic crane at radii or boom lengths where the capacity charts in the Crane Rating Manual shows no capacity. Don't use a fly not designed for your crane. Either of the above can tip the crane over or cause attachment failure. In some cases, the crane can tip over with no load on the hook, forward or backward! Also, if the boom is fully extended at a low angle, the crane may tip until the boom touches the ground. In any of these cases, injury or crane damage could result.
15. When a load is lifted with any crane, the load may swing out, or sideways. The load radius will increase. Due to the design of hydraulic crane booms, (cantilever boom, supported by cylinders and overlapping sections) this increase is much more pronounced. The increase or out swing of the load can overload the boom, and lead to boom failure or tipping. Also, movement of the load can cause it to hit something. Ensure the load being lifted will remain within capacity as it is lifted and the boom deflects.

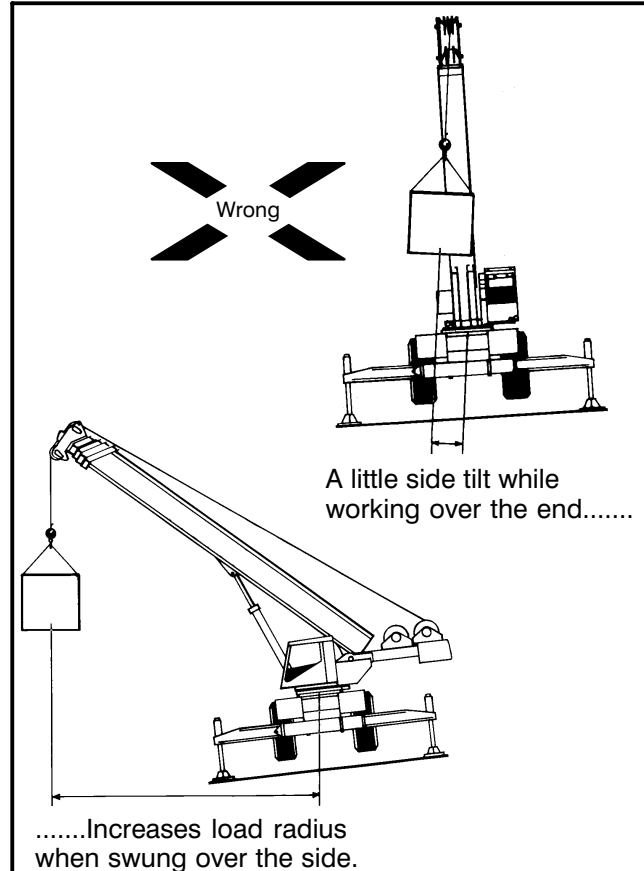
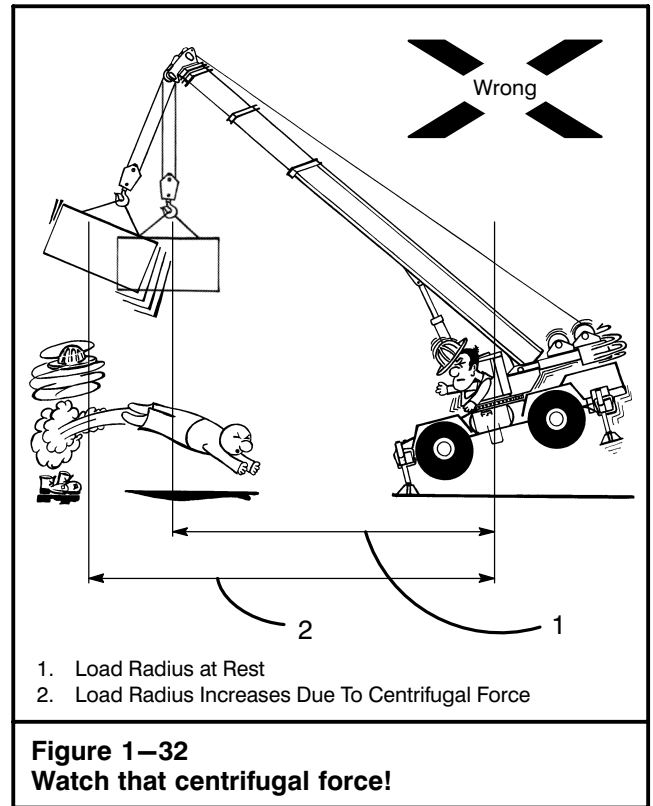

Figure 1-31
Watch that side tilt!

16. When extending or lowering a boom with a load, the load radius increases. As the load radius increases, capacity decreases. If capacity is exceeded, the boom may bend or the crane may tip over. Sometimes at low angles, a hydraulic crane boom can be extended with a load, but cannot be retracted. This is because more power is available in the boom cylinders to extend than to retract. If an operator extends the boom under load, he may not be able to retract the boom and may get into a dangerous situation.
17. Know the boom length. Don't guess. Use of an incorrect boom length can cause an accident.
18. When lowering or retracting the boom, the load will lower. To compensate for this, the operator must hoist up on the winch wire rope. Otherwise, movement of the load may cause an accident. When extending the boom, the load will raise. The operator must hoist down the winch wire rope to keep the load in place. Extending the boom without winching down, can lead to "two blocking". This is when the hook block, hook ball, and/or the load contacts the head machinery. Two blocking can lead to sheave or wire rope damage.

19. The winch wire rope must be vertical when starting to lift. If not, the load will swing in, out, or sideways when lifted from the ground. The crane will lean toward the load when lifting heavy loads. This is caused by elasticity of the crane and the boom. This lean will increase operating radius so the load will swing outward when it clears the ground. This out swing is dangerous to anything in the path of the load, and because of the increase in load radius may overload the crane. To overcome this out swing, boom up as the load is lifted so winch wire ropes remain vertical. When setting the load on the ground, lower boom after the load touches down to avoid hook block and/or hook ball swing when it is unhooked from load.
20. Pinch points, which result from relative motion between mechanical parts, can cause injury. Keep clear of the rotating upper or moving parts.
21. Lifting heavy loads can cause the crane to tilt or lean toward the load. When swinging a load from over the end to over the side, the tilt of the crane will increase. Since tilt acts to increase load radius, it must be compensated for when swinging the load. Swing slowly. Change boom angle (raise the boom) while swinging, to maintain a constant radius, and prevent in swing or out swing of load. If not, a dangerous condition could result.
22. Watch out for centrifugal force when swinging a load. Swing gently. Centrifugal force tends to increase load radius. This increase in radius could overload the crane and cause crane damage or tipping. When stopping the swing, over swing of the load can side load the boom.
23. Keep the winch wire ropes as short as possible to prevent excessive swinging. Always use the shortest boom length which will do the job. Remember – the shorter the boom, the better the capacity.
24. Due to inertia (weight), a load will momentarily tend to stay in position when the crane starts to move. For this reason do not back the crane away from a suspended load when handling near capacity loads. The inertia effect will tend to increase load radius and decrease stability. Use hand lines as required to control the load.



25. Don't increase the counterweight. Don't add anything to the crane that will act as additional counterweight. Remember that anything which has weight, if carried behind the crane's center of gravity, acts as counterweight. Adding counterweight affects backward stability of the crane, particularly when working over the side. It also encourages overloading of the crane.
26. Working areas for cranes are defined per the Working Areas chart in the Crane Rating Manual. Permissible loads, per the Crane Rating Manual, will vary from lifting quadrant to lifting quadrant. The operator must ensure capacity ratings are not exceeded regardless of which quadrant he is operating in, or when swinging from one quadrant to another.
27. When working on tires, the tires must be inflated to pressures shown on the Tire Inflation Label on the carrier and/or the Tire Inflation Chart in the Crane Rating Manual.

Operator's Manual

Traveling

1. Traveling with a suspended load should be avoided if possible. It is especially hazardous when terrain is rough or irregular, on a side slope, or in a hilly area. When traveling with a load, observe the following rules:
 - a. Use a hand line to control the load and reduce load swing.
 - b. Travel by the smoothest, most level route. If a smooth, level route is not available, don't travel with a suspended load. Grade the route to provide a smooth, level path. If it is not possible to grade the route, move the load by stepping. Level the crane on outriggers, lift the load and set it down ahead of the crane. Travel the unloaded crane beyond the load, level the crane on outriggers, lift the load, swing and set it down farther along the route. Continue this procedure until the load is at its destination.
 - c. Carry loads as close to the ground as possible.
 - d. Do not allow side swing of the load.
 - e. Don't attempt to carry loads which exceed the crane's rating. Refer to On Tires and Pick And Carry capacities shown in the Crane Rating Manual.
 - f. Don't travel with a load on soft ground. If the crane sinks into ground, stability can be affected to the point of tipping the crane.
 - g. Keep all personnel clear of crane and load. Be prepared to set load down quickly at any time.
 - h. Fully extend outrigger beams. Extend or retract jacks until pontoons just clear the ground.
 - i. Check clearance for the extra width of the crane with the outriggers extended. Outrigger beams or pontoons must not hang on any obstruction.
 - j. Inflate tires as shown on the Tire Inflation Label or in the Crane Rating Manual when making lifts on tires.
 - k. See "Pick And Carry Operation" in this Section of this Operator's Manual for more details.
2. When traveling on the highway, road the crane safely. Watch for narrow bridges and low clearances. Check load limits, height, width, and length restrictions in the area you are traveling. Ensure the crane complies with all regulations.
3. When roading the crane, note the following:
 - a. Operate with lights on. Use proper warning signs, flags, and other devices. Use an escort service if required.
 - b. Engage travel swing lock. Release the 360° swing lock.
 - c. Tie down or otherwise restrain the hook block and/or hook ball.
 - d. Check for maximum allowable travel speed and any other travel limitations. Don't exceed these maximums. Crane damage or an accident could result.
 - e. Inflate tires as shown on the Tire Inflation Label when traveling on highway.
 - f. When traveling, outriggers must be fully retracted.
 - g. Remove all pontoons from the outrigger jacks and store them properly.
4. If the crane must be towed, refer to "Towing The Crane" in this Section of this Operator's Manual for specific instructions.

Operator's Manual

Leaving The Station

1. Do not get on or off a crane in motion. When climbing on the crane, remain in three point contact with the crane at all times (two hands and one foot or two feet and one hand). If a ladder is provided, use it.
2. Whenever an operator leaves the control station for any reason, the following must be done:
 - a. Lower the load to the ground.
 - b. Tie down the hook block and/or hook ball. Do not leave them where the wind could swing them to cause damage to the attachment and/or nearby objects.
 - c. Engage swing lock. Engage the park brake. Shutdown the engine and remove the keys.
 - d. Do not depend on a brake to suspend a load unless the operator is at the controls, alert and ready to handle the load. Brake slippage, vandalism, or mechanical malfunctions could cause the load to drop.
3. Do not leave crane unattended with engine running.
4. When changing work shifts, notify the next operator of any changes or problems with the crane.
5. Hydraulic cylinders, left extended under load, often-times have a tendency to drift in (retract) due to internal fluid passage in the cylinders and/or control valves. Do not shutdown the crane and leave it unattended for extended periods of time, i.e. overnight, with the boom positioned over anything or the crane itself that the boom could damage if it should lower. For instance the boom hoist cylinder may drift allowing the boom to lower and damage the engine hood. Position the boom over the front to avoid the engine hood on the rear of the crane.



Operator's Manual

Personnel Handling Guidelines

Introduction

The following information is intended to provide Link-Belt's recommended minimum requirements that must be followed when handling personnel with a personnel basket or work platform (hereafter referred to as a work platform) suspended by wire rope from the boom of Link-Belt cranes. These requirements are based upon several sources and are put forth in recognition of current industry practices. However, safety, when handling personnel, remains the full responsibility of job site management and is dependent upon the responsible action of every person on the job involved in the related work.

This information is intended to supplement and not to supersede or replace any more restrictive federal, state, or local regulations, safety codes, or insurance requirements. It is intended to serve users of personnel work platforms in achieving the following objectives.

1. Reduce risk of personal injuries to users and the public.
2. Inform users of their respective responsibilities.
3. Provide standards of equipment requirements.
4. Provide standards for tests and inspections.
5. Provide standards of operation to promote safety.

Link-Belt cranes are designed and intended for handling material. They are not normally equipped with secondary systems or other devices required by personnel lift or elevator standards and are not intended for handling personnel for construction or amusement purposes. Use of cranes for these purposes is hazardous and is not recommended by Link-Belt. However, Link-Belt understands that circumstances may occur (in construction work) when lifting or lowering personnel on a materials handling crane load line is the only or the least hazardous method available to position personnel. In fact, Occupational Safety and Health Administration (OSHA) Part 29, CFR 1926.1431 states "The use of equipment to hoist employees is prohibited except where the employer demonstrates that the erection, use, and dismantling of conventional means of reaching the work area, such as personnel hoist, ladder, stairway, aerial lift, elevating work platform, or scaffold, would be more hazardous, or is not possible because of the project's structural design or worksite conditions."

Much corollary and supplementary information is contained within the following resource documents pertaining to both cranes and personnel work platforms. Job site management must ensure all requirements listed in these resource documents are followed for all personnel handling operations.

- American National Standards Institute Reference – ANSI Standards A10.28, A92.2, A92.3, and American Society of Mechanical Engineers – ASME, ANSI/ASME B30.5, and B30.23.
- Power Crane and Shovel Association (PCSA) Bureau of the Association of Equipment Manufacturers (AEM) Reference – PCSA Standard No. 4.
- American Petroleum Institute (A.P.I.) Specification 2C.
- OSHA Part 29, CFR 1926.1431 Cranes and Derricks.

Authorization

Authorized use of a work platform may be permitted only after the following on-site procedures have been performed:

1. A competent person on the job site (job site manager) specifically responsible for the overall work function to be performed has determined that there is no practical alternative means to perform the needed work and has authorized a personnel lifting operation.
2. For each instance of such lifting, a competent person responsible for the task has attested to the need for the operation by issuing a written statement describing the operation and its time frame and itemizing that each of the on-site authorization requirements has been met. The written statement, after being approved by a qualified person, shall be retained at the job site. (Refer to *Personnel Handling Pre-Lift Check List For Link-Belt Cranes* in this Section for a sample check list.)
3. Review of crane inspection records has been conducted to ensure the crane being used meets applicable provisions in ANSI/ASME B30.5 and B30.23.
4. Review of the work platform inspection records and specifications has been conducted to ensure it meets applicable design standards (refer to ANSI A10.28).
5. Review of the personnel lifting operation practices specified in these instructions have been conducted with job site managers and crane operator(s), foreman, designated signal person, personnel to be lifted, safety supervisor, and any other person(s) who has jurisdiction over the operation to ensure that they are aware of the hazards of the operation and they are aware of provisions of these instructions that must be adhered to before and during the personnel lifting operation.

Operator's Manual

Equipment

1. The crane system shall be equipped with the following:
 - a. A fully functional working operational aid such as a Rated Capacity Limiter (RCL) system – A system consisting of devices that sense crane loading, boom length (extendable booms only), boom angle, and also automatically provide an audible/visual signal when the loading conditions approach, reach, and/or exceed the rated capacity values. When the Actual Load exceeds the Rated Capacity, the system supplies a signal to a function cutout system. The operational aid shall be equipped with these additional devices:
 1. Anti-two block device to prevent damage to the hoist wire rope, other crane components, or attachments, and subsequent endangerment of personnel.
 - It is required that the anti-two block device warn both audibly and visually as well as have the capability to cutout the controls/functions that may cause a two block condition.
 2. Boom angle indicator.
 - Cranes with extendable booms must utilize a boom angle indicator having “high and low” set points and audible/visual alarm(s) capable of activating function cutouts.
 - b. Boom hoist and load line shall have power lowering and raising and shall have an automatic brake which is applied when the applicable control is in neutral, or when the anti-two block device is actuated.
 - c. If the crane is equipped with a “free-fall” hoist, steps shall be taken to ensure its use is not possible during the use of the work platform. (Note: A.P.I. applications do not permit the crane to be equipped with free-fall.)

- d. Each crane shall have a mechanical swing park brake or swing lock capable of being set at any swing position, and shall have a variable swing brake or swing controls capable of stopping the upper swing motion smoothly. The swing brake must be properly maintained at all times to ensure its holding capability.

Note: All operational aids and equipment must be maintained in operable condition. Alternative measures are not permitted.

2. The work platform shall be designed by a qualified engineer competent in structural design. Its maintenance, and its attachment to the crane load line, is the responsibility of the job site management. Their arrangement shall comply with the following as a minimum:
 - a. The work platform harness must be of sufficient length to prevent any portion of the work platform or the harness from coming in contact with the boom at any working boom angle.
 - b. Audible and visual alert systems shall be provided to the personnel in the work platform to signal for assistance in the event of an emergency.
 - c. Hooks on hook block assemblies, hook ball assemblies, or other assemblies, shall be of a type that can be closed and locked, (with a working safety latch) eliminating the hook throat opening, and shall be full load-bearing, and contain a manual trigger release.
3. No unauthorized alterations or modifications are allowed to be made to the basic crane.

Maintenance, Lubrication, And Adjustments

1. The crane operator must have a complete understanding of the crane's maintenance, lubrication, and adjustment instructions as outlined in the Operator's Manual.
2. The crane shall be maintained, lubricated, and adjusted, by a designated person, as specified in the Operator's Manual.
3. The crane and work platform decals must be understood and maintained.
4. All decal precautions and instructions shall be strictly observed.

Operator's Manual

Inspection And Rigging

1. The lift crane and work platform shall be inspected immediately prior to commencement of operation. (Refer to the Crane Operator's Manual and ANSI B30.5, Section 5, Section 5–2.1.2 and 5.2.4, and ANSI/ASME B30.23 for the required inspection procedures for the crane. Refer to ANSI A10.28 for inspection procedures required for the work platform.)
2. The inspection shall be performed once daily when the crane is being used in work platform service or each time the crane is converted from material lifting to personnel handling operation. In the event the operator is replaced, a new inspection is required. Written documentation of all inspections must be kept on the job site during personnel handling operations.
3. Inspect the crane and work platform for any loose, damaged, or missing components.
4. Any structural or functional defect which adversely affects the safe operation of the lift crane shall be corrected before any operation utilizing a work platform begins or continues.
5. The hoist drum shall have at least three full wraps of wire rope remaining on the drum at all times when using a work platform.
6. Minimum load hoist and boom hoist wire rope design factors for the combined weight of the lift attachments, work platform personnel, and tools shall be 10:1 for "Non-Rotating" and "Rotation Resistant" wire ropes. All other wire rope types require a 7:1 design factor. (Note: A.P.I. applications require 10:1 design factor for all wire rope construction.)
7. The work platform shall be suspended from a wire rope that is reeved from an allowed lifting sheave. Refer to "Lifting Sheaves For Personnel Handling With Suspended Work Platforms" chart to determine the allowed sheave(s).
8. Inspect the wire ropes, sheaves, hoist drum brakes, and other mechanical and rigging equipment vital to the safe operation of the crane.
9. Ensure that all wire rope sockets and dead end lugs are properly installed and are in good working condition.
10. Ensure that all wire rope guards are in good working order and that they are properly installed and adjusted to prevent wire rope from jumping off sheaves.
11. Inspect all structural members of all boom sections, fly sections, luffing jib sections, and live mast, as equipped.
12. In addition to other regular inspections, visual inspection of the crane and work platform shall be conducted immediately after testing and prior to lifting personnel. The following inspections shall be conducted on extendable booms prior to lifting personnel:
 - a. Full power style booms:
 1. Inspection of all extension wire ropes at the access points in the boom where the end connections are visible – Refer to the Operator's Manual for inspection and adjustment procedures.
 - b. Pinning and latching style booms:
 1. Inspection of the latching mechanism, sensors, and hydraulic/electrical circuit at the access points.
 2. Inspection of all pins and pinning locations in the individual boom sections and at the fully retracted position.
 3. Verification of the accuracy of the boom length indicator. Refer to the Operator's Manual for the procedures.
13. The following inspections shall be conducted on fixed length style booms prior to lifting personnel:
 - a. Inspection of all pendants, pendant links, pendant spreader bars, links, etc.
 - b. Inspection of all mechanical linkages, shafts, drums, etc.
14. A written record of all the above inspections must be maintained on the job site.

Operator's Manual

Crane Test Procedures

The test procedures listed below shall be conducted at the following intervals:

- Daily,
- At each job site before hoisting employees,
- After any repairs or modifications to the equipment,
- When an operator is replaced, and
- When, in the judgement of responsible job site management, or controlling entity, there has been a significant change in the conditions of the personnel lifting operation.

Note: No personnel are allowed to ride the work platform during any of the tests recommended in this Section.

1. The work platform and rigging shall be proof tested to 125 percent of the work platform's rated capacity. (The proof test may be done concurrently with the trial lift by completing the following test procedures.) Do not exceed the rated lifting capacity of the applicable lift crane as listed on the crane capacity charts. (Refer to ANSI A10.28 for suspended work platform testing and inspection.)
 - a. This test load shall be tested for stability.
 - The operator and signal person shall conduct this test.
 - This test shall include movement of the work platform through its entire intended range of motion, simulating the specific operation to be undertaken.
 - A successful stability test must not produce instability of the crane or cause permanent deformation of any component.
 - b. This test load shall be raised and lowered at maximum power controlled line speed (NOT FREE-FALL). The acceleration must be smooth and the deceleration capability of the control/braking system shall be confirmed by bringing the work platform to a smooth stop. The work platform shall be held in a suspended position for a minimum of five minutes with the test load evenly distributed on the work platform. (This experience is intended to sharpen the skill of the operator in handling the work platform and to give the operator an opportunity to evaluate the crane's performance.) The work platform shall then be inspected for any evident sign of damage or defect.
2. All limiting and warning devices shall be tested by activation of each appropriate control function.
3. With pinning and latching style extendable booms, a visual inspection shall be conducted to verify that the boom extend pins are properly set in the extended boom sections.
4. At the beginning of each lift, the work platform must be hoisted a few inches (*mm*) with the personnel and materials/tools on board and inspected by a competent person to ensure;
 - The work platform is secure and properly balanced,
 - All wire ropes are free of deficiencies such as kinking, crushing, corrosion, etc.,
 - Any multiple part lines are not twisted,
 - The primary attachment is centered over the work platform, and
 - If any load rope is slack, it must be inspected to ensure that all ropes are properly seated on the drum and in the sheaves.
5. Any condition found during any of these tests/inspections that fails to meet requirements or may create a safety hazard, must be corrected before hoisting personnel.

Operator's Manual

| | | | | |
|---|--|--|---------------------------------|------------------------------|
| Telescopic Booms | Main Boom Head Sheaves | Auxiliary Head Sheaves | Fixed Fly Sheave | |
| | Allowed | Allowed | Allowed | |
| | Offset Fly Sheave | Offset Fly With Extension(s) Sheave | A–Frame Jib Sheave | |
| | Allowed | Allowed | Not Recommended | |
| Conventional Lattice Tubular or Angle Booms | Main Boom Head Sheaves | Tip Extension Sheaves | Jib Head Sheave | |
| | Allowed | Allowed | Allowed | |
| Luffing Attachments | Luffing Boom Auxiliary Head Sheaves | Midfall Sheaves | Luffing Jib Head Sheaves | Fixed Jib Head Sheave |
| | Not Recommended | Allowed | Allowed | Not Recommended |
| Lifting Sheaves For Personnel Handling With Suspended Work Platforms | | | | |

Operation And Safety

1. The Operator's Manual for the crane shall be read and fully understood by operating personnel. The Crane Operator's Manual shall be available to them at all times.
2. Safety when handling personnel remains the full responsibility of job site management and is dependent upon the responsible action of every person on the job involved in the related work.
3. Mobile lift cranes shall be erected to obtain maximum crane stability. The crane must be level and on firm ground. It is recommended that the outriggers be fully extended and the tires must be clear of the ground before beginning any operation.
4. The operator shall not leave the operator's station when the work platform is occupied. The operator shall remain alert in a position of readiness at the work station with the engine running and the master clutch engaged, if crane is so equipped.
5. Unauthorized personnel shall not be in the operator's cab on the lift crane, or near the lift crane while a work platform is suspended from the load line.
6. Any operation in which a work platform is to be suspended from the load line shall be carefully planned by the operator, supervisory personnel, designated signal person, and personnel to be lifted prior to commencement of such operation. They are to be advised:
 - a. That the crane does not have safety devices normally used on personnel handling equipment.
 - b. That the safety of the operation depends on the skill and judgment of the crane operator and others present.
 - c. Of procedures to enter and leave the work platform and other safety procedures.
7. After positioning of the work platform:
 - a. All brakes and locks on the lift crane shall be set before personnel perform any work.
 - b. With pinning and latching style extendable booms, a visual inspection shall be conducted to verify that the boom extend pins are properly set in the extended boom sections.
8. Telescope operation is not recommended with any extendable boom with personnel in a suspended work platform.
9. A work platform attached to load line of lift cranes shall not be used for working on any energized electric power line, or any energized device or facility used for electric power generation or transmission. Minimum working clearance shall be at least twice that recommended for material handling operations in ANSI B30.5b section 503.4.5 and ANSI B30.23.
10. The combined weight of the work platform, any attachment device, personnel, tools, and other equipment shall not exceed 50% of the lifting capacity of the applicable lift crane as listed on the crane capacity chart. (Note: A.P.I. applications require 25% of lifting capacity as the limit.)
11. Use caution when utilizing pendant supported lattice jibs on tubular or angle booms as the jib can drift backwards into the jib backstops under certain conditions. This is most likely with short jib lengths with minimum jib offset and maximum boom angle. Pay special attention to detect the possibility of jib drift during the work platform test lift. An additional test lift is recommended with an empty work platform when operating under these conditions.
12. The following actions and operations are strictly prohibited when working with personnel suspended in a work platform:

Operator's Manual

- a. Cranes shall not travel while personnel are in the work platform.
 - b. No lifts shall be made on another of the crane's load lines with personnel suspended in a work platform.
 - c. No external load is allowed to be lifted by attaching it to the work platform.
 - d. Work platform lifts shall be a single crane operation. A work platform shall not be lifted using two cranes.
 - e. Hoisting of personnel shall be discontinued upon indication of any dangerous weather conditions, wind, or other impending danger.
 - f. The emergency manual mode operation of pinning and latching style extendable booms shall not be utilized.
 - g. Free-fall (if equipped) shall not be used.
13. Movement of the work platform with personnel shall be done in a slow, controlled, cautious manner with no sudden movements of the crane or work platform. Do not use high speed functions, if equipped.
 14. Do not use multi-function crane operation. If load hoist, boom hoist, and swing functions must be used to position the work platform, perform each function individually.
 15. Clear, unobstructed visibility between personnel on the work platform and the crane operator shall be maintained at all times except where a designated signal person has been assigned and positioned such that he is visible to both. Such designated signal person shall have no other duties to perform when personnel are in the work platform.
 16. Voice communication between work platform personnel, the crane operator, and designated signal person, if assigned, shall be maintained.
 17. If other cranes or equipment may interfere with the lifting of personnel, signals or other means of communication between all crane or equipment operators shall be maintained to avoid interference with individual operations.
 18. If the work platform is not landed, it shall be tied to a structure before personnel mount or dismount the work platform.
 19. Personnel in the work platform shall wear personal fall arrest systems. Anchors used for attachment of personal fall arrest equipment shall be independent of any anchors being used to support or suspend work platforms. Personnel shall keep all parts of body, tools, and equipment inside work platform during raising, lowering, and positioning.
 20. Personnel shall always stand firmly on the floor of the work platform and shall not sit or climb on the edge of the work platform or use planks, ladders,

or other devices for attaining a work position. (This does not apply to offshore personnel transfer baskets. Personnel must ride on the exterior of this type of personnel handling device to assure greater safety of the operation.)

21. When welding is done by personnel in the work platform, the electrode holders shall be protected from contact with metal components of the work platform. If electrically connected electrode holders contact work platform, work platform could be dropped due to burning/melting of wire ropes suspending the work platform.
22. A pre-lift meeting must be conducted with the crane operator, signal person, employee(s) to be hoisted, person responsible for the task to be performed, and anyone else that is directly involved with the lift (as applicable) to review all the requirements and procedures that must be followed to complete the lift.
23. Follow all procedures for determining the rated capacity and perform all testing as outlined in the Crane Operator's Manual, the Crane Rating Manual, and this Safety Manual.

Additional Requirements For Offshore Cranes

1. Link-Belt offshore cranes are designed to handle materials. However, due to the special conditions commonly existing offshore, the use of cranes to transfer personnel between vessels or from a vessel to a work platform is an established practice. The safety of the personnel, if a materials handling crane is used in transferring personnel, depends upon the skill and judgment of the crane operator and alertness of the personnel being transferred. Sea and weather conditions may create additional hazards beyond the skill of persons involved.

This operation is approved by the American Petroleum Institute (A.P.I.). By adopting procedures for this operation, the institute has determined that the transfer of personnel may be performed safely under certain offshore conditions. Therefore, whenever an offshore crane is used to transfer personnel, all persons involved in the operation must know and implement the A.P.I. procedures and verify that sea and weather conditions are within safe limits for the transfer.

In addition to all previous requirements in these Instructions, A.P.I. 2C requires the following:

- Boom and load hoists used shall be approved by the hoist manufacturer for personnel handling and shall be so indicated on their name plate.
- Refer to A.P.I. 2C Section 6 for further details and procedures.

Operator's Manual

Personnel Handling Pre-Lift Check List for Link-Belt Cranes



| | |
|----|--|
| 1 | <p>I am the designated person responsible for verifying that all safety requirements are met for this personnel handling operation;</p> <p>Name: _____ Title: _____</p> <p>Signature: _____ Date: ____/____/____ Initials</p> |
| 2 | I have verified that there are no conventional means to handle personnel for this operation. |
| 3 | I have a written statement authorizing personnel handling from a competent person on the job who accepts full responsibility, or I accept full responsibility for the operation. |
| 4 | The Crane Operator acknowledges that he has read and fully understands the Crane Operator's Manual and Crane Rating Manual. All personnel involved have been informed and understand the tasks required to complete the personnel lifting operation. |
| 5 | The crane has been maintained, lubricated, and adjusted by a designated person, as specified in the Crane Operator's Manual. |
| 6 | <p>The lift crane is equipped, and all devices operate properly as follows:</p> <ul style="list-style-type: none"> • Anti-two block device with hydraulic cutouts • Power load raising and lowering with automatic brakes and function cutouts – Free-Fall (if equipped) shall not be used • Boom angle indicator with high and low set points and function cutouts • Boom length indicator (telescopic booms only) and function cutouts • Load Indicating System or Rated Capacity Limiter System • A variable swing brake or swing controls capable of stopping upper swing motion smoothly • A mechanical swing park brake or swing lock to hold the upper in position while personnel are working from the work platform • Hook block or hook ball being used can be closed and locked with a safety latch |
| 7 | A working audible and visual alert system is provided to the personnel in the work platform. |
| 8 | A mechanical and structural crane inspection has been completed by a designated person. |
| 9 | The wire rope used to lift the work platform is reeved from an allowed lifting sheave |
| 10 | Crane travel is not allowed with personnel in the work platform. |
| 11 | Telescoping the boom is not recommended with personnel in the work platform. |
| 12 | When handling personnel with pinning and latching style booms, it is recommended boom be kept in a pinned position. Inspections must be made to ensure boom extend pins are set. |
| 13 | All wire rope sockets and dead end lugs are properly installed and are in good working condition. All Wire rope guards are properly installed and adjusted to hold all ropes on the appropriate sheaves. |
| 14 | Voice communications between the Crane Operator and the personnel in the work platform are present and operational. |
| 15 | Fall arrest systems are present and in use by personnel in the work platform. |
| 16 | Weather and wind conditions are acceptable to safely perform the lift. |
| 17 | A Proof-Test/Trial Lift was completed with 125% of the work platform's rated capacity. |
| 18 | The total load being lifted will not exceed 50% of the standard lift crane capacity charts. |
| 19 | Cranes with outriggers have them equally extended with tires clear of the ground. |
| 20 | A Pre-Lift meeting was held with all appropriate personnel to review all aspects of the lift. |

Note: This checklist is to be used as a supplement to (not a substitute for) the information and procedures supplied for personnel handling operations.

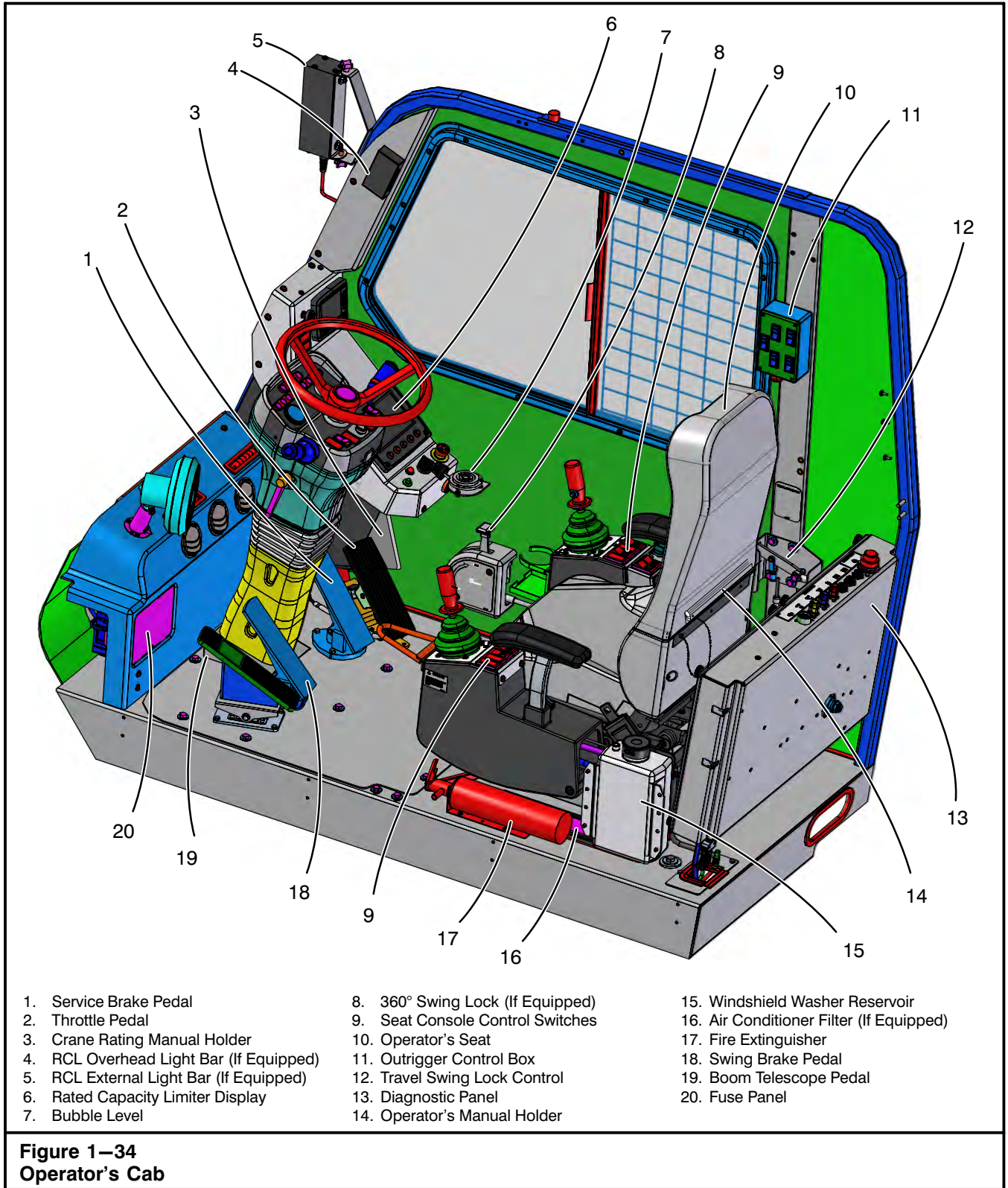

Operator's Cab

Several panels which contain the controls, switches, and gauges to operate and monitor crane operations

are mounted throughout the operator's cab.. Refer to Figure 1–34. The following is a description of each gauge, switch, or control in each panel, along with an explanation of their function and/or operation.

Operator's Manual

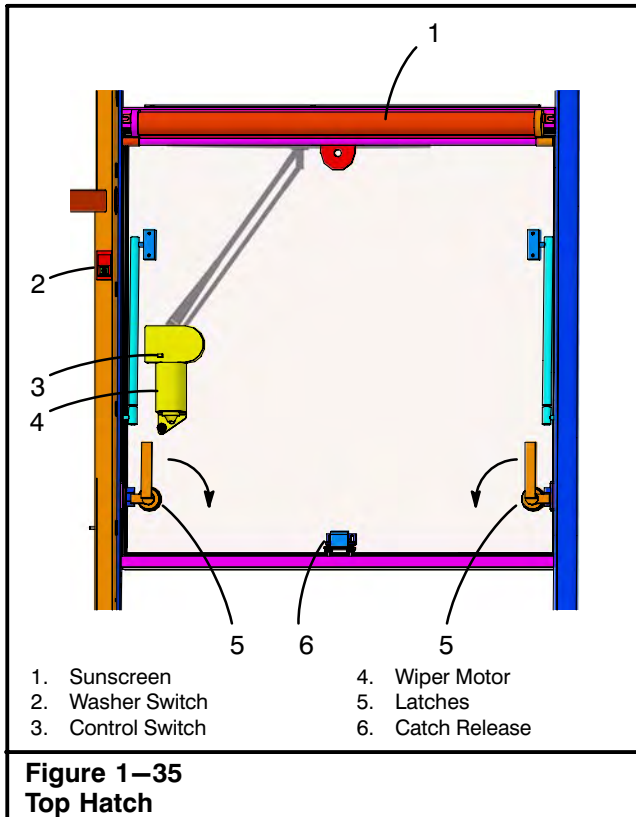

Fire Extinguisher

A fire extinguisher is mounted in the operator's cab below the left console. Raise the left console to gain access to the extinguisher. It is an A B C type fire extinguisher, meaning it is capable of extinguishing most types of fires. The operator should be familiar with its location, the clamp mechanism used to secure it in place, and foremost the operation of the device. Specific instructions, regarding operation, are given on the label attached on the fire extinguisher. A charge indicator on the fire extinguisher monitors the pressure within the tank. Check the indicator daily to ensure the fire extinguisher is adequately charged and ready for use.

Top Hatch

Top Hatch Wiper And Washer

The top hatch wiper is mounted in the top right corner of the cab roof. Refer to Figure 1–35. The switch for the top hatch wiper is mounted on the wiper motor. Move the switch to the "ON" or "OFF" position as desired. To wash the window, push the washer switch to spray washer fluid on the top hatch window.

Top Hatch Window

The top hatch window can be opened to improve cab ventilation. To open the top hatch window, rotate the latches, press the catch release, and push up on the hatch window.

Top Hatch Sunscreen

The top hatch is equipped with a roller sunscreen to assist operator vision when looking up through the top hatch.

Upper Operator's Cab Fuse Panel

The fuse panel is in the lower left front corner of the upper operator's cab. Refer to Figure 1–34. A label which designates the electrical circuit protected by each fuse is on the fuse panel cover. Refer to Figure 1–38. Each fuse has a letter designation which corresponds to the upper electrical system as shown on the fuse identification label.

Windshield Washer Reservoir

Check the windshield washer reservoir daily. The reservoir for washer fluid is mounted in the lower left rear of the cab. Refer to Figure 1–34. Visual inspection can determine if the washer fluid is adequate. Do not operate the washer when the reservoir is empty. Use specially formulated windshield washer fluid rather than water because specialty washer fluids contain additives that dissolve road grime.

Bubble Level

The bubble level is provided to assist the operator in leveling the crane on outriggers. It is mounted on the right cab wall. Refer to Figure 1–34.

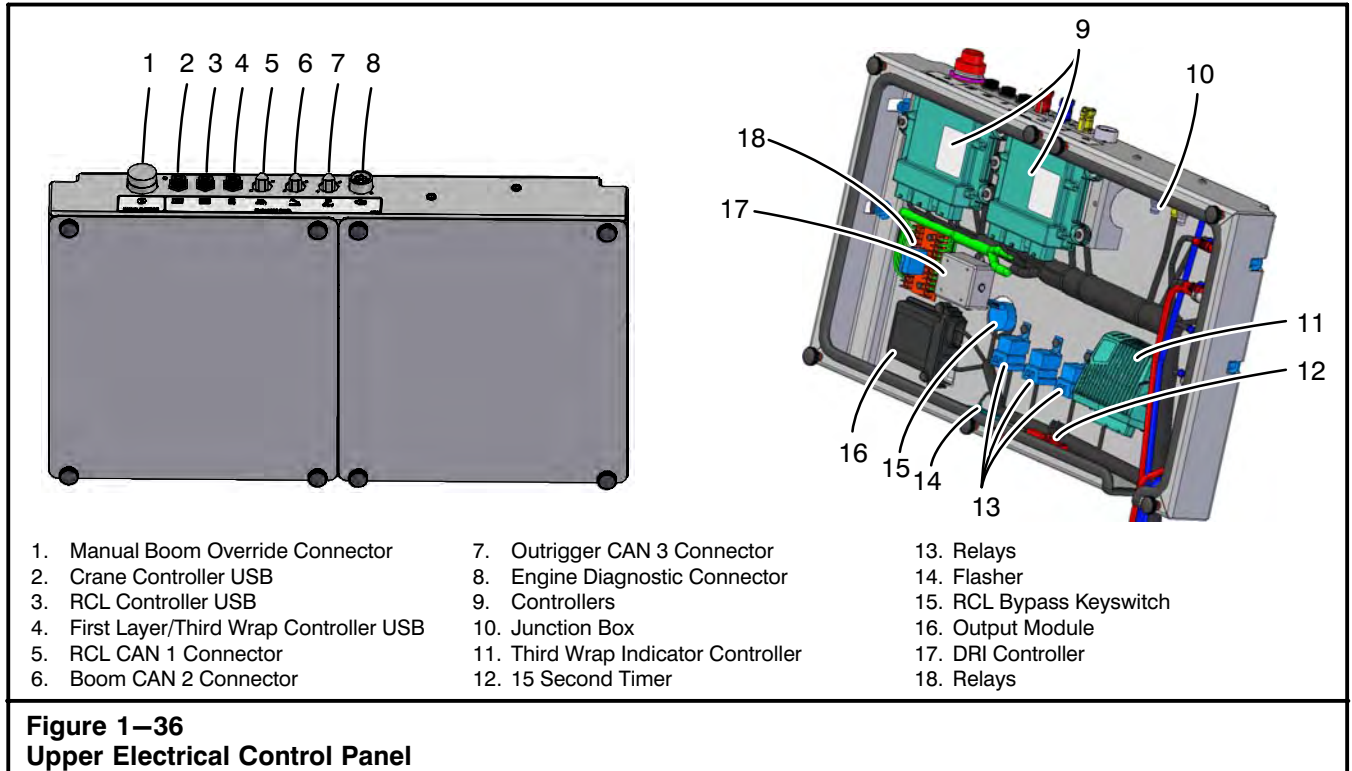

Upper Electrical Control Panel

The Upper Electrical Control Panel is behind the operator's seat. Refer to Figure 1-34. The central location allows easy access for technicians to retrieve fault codes and conduct systematic troubleshooting of various upper control systems. A label which identifies each connector is on the panel.

Manual Boom Override Connector

The Manual Boom Override Connector is used to plug the emergency telescope control box to telescope the boom manually in case of emergency. Refer to "Emergency Telescope Operation" in this Operator's Manual.

RCL Bypass Keyswitch

The RCL Bypass Keyswitch is in the upper electrical control panel and can be accessed from the rear of the cab. Refer to Figure 1-36 and Figure 1-37. The RCL bypass keyswitch is used to bypass the Rated Capacity Limiter computer in emergency situations. Refer to "Crane Monitoring System" in this Section of this Operator's Manual.

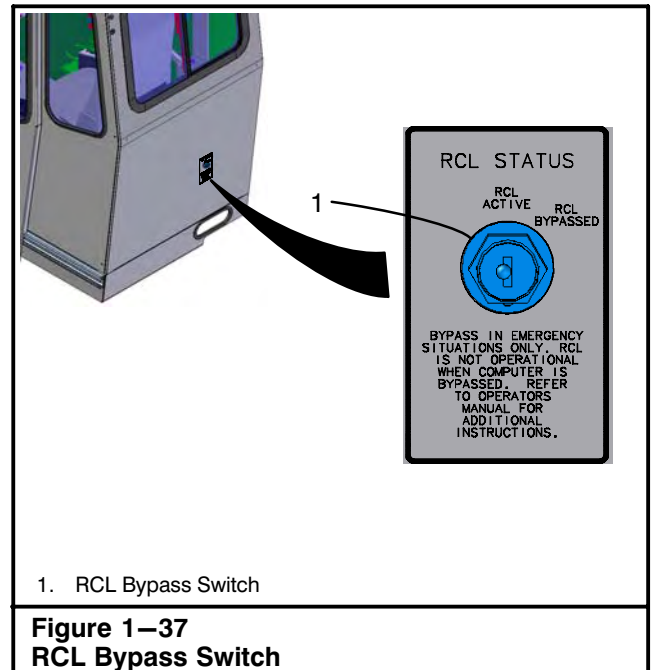

Operator's Manual

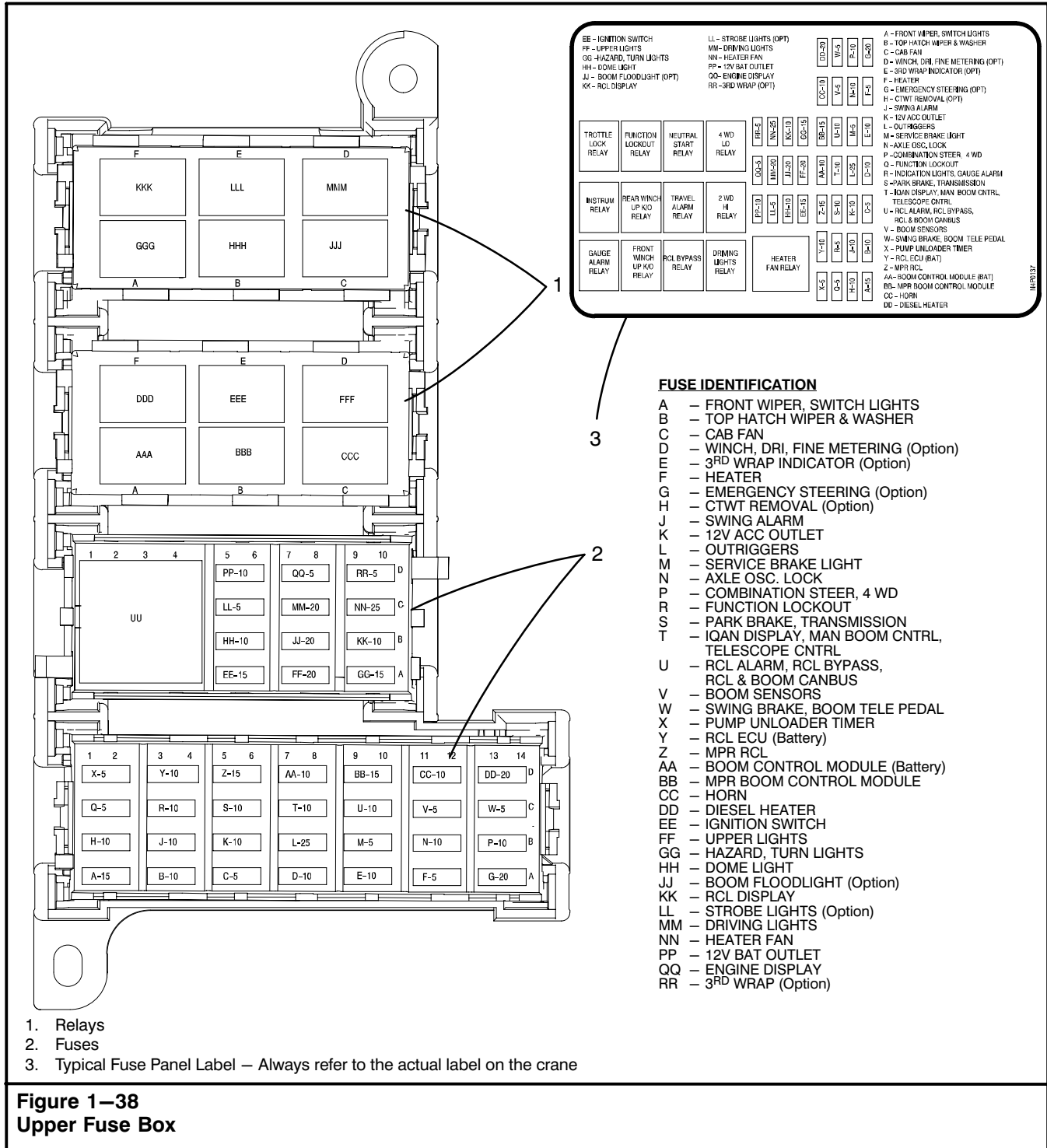

Upper Fuse Box

The upper fuse box is mounted behind the fuse panel in the cab. Refer to Figure 1–34 and Figure 1–38. Re-

move the fuse panel to gain access to the fuses. A label which designates the upper electrical circuit protected by each fuse is on the back of the fuse panel. Use the fuse puller provided to replace a fuse.

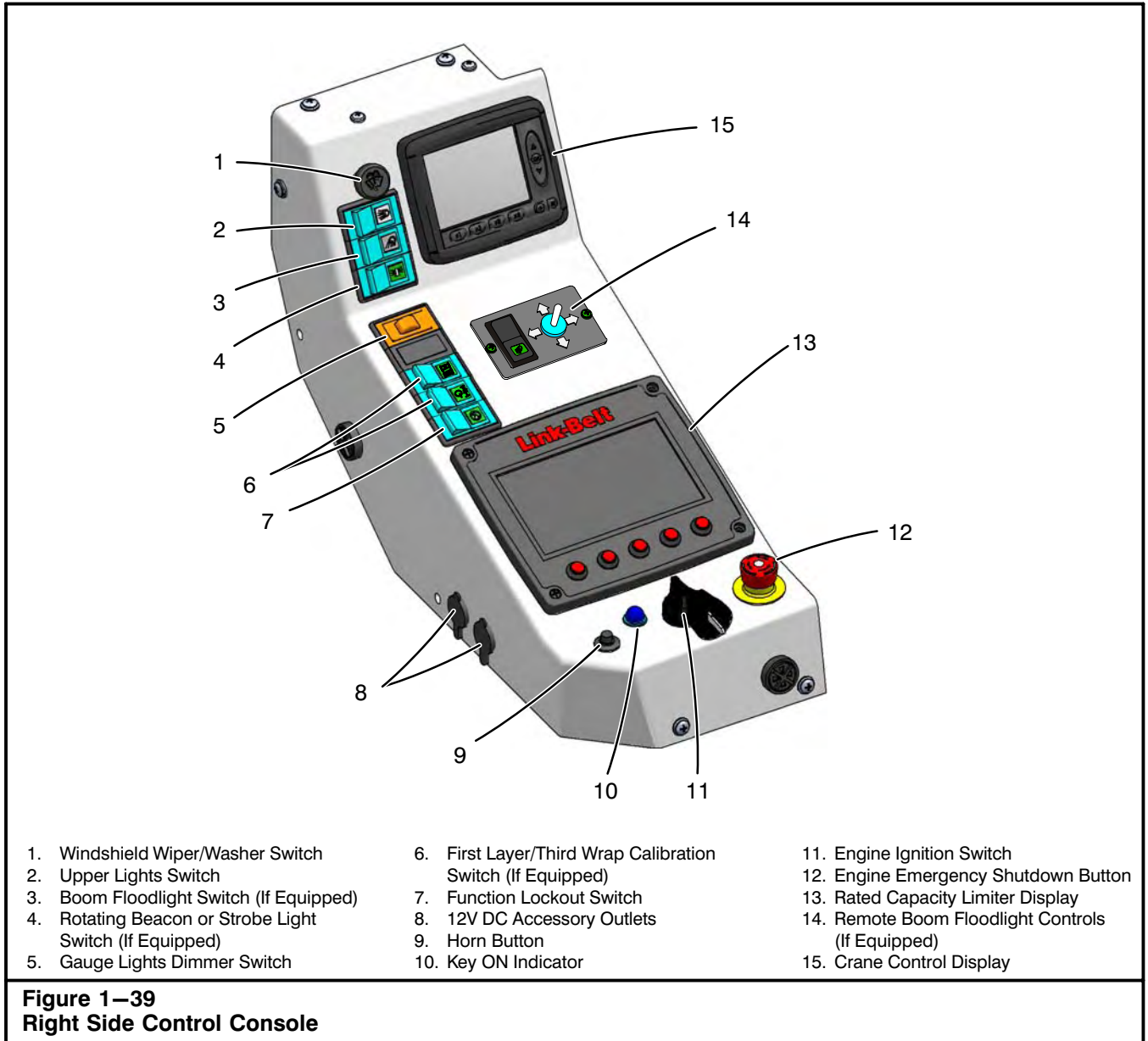

Right Side Control Console

A control panel is in the right front corner of the operator's cab that contains the following controls, gauges, and indicators. Refer to Figure 1–39.

1. Windshield Wiper/Washer Switch



Rotate the wiper/washer knob clockwise to activate the windshield wiper. Rotate the knob to the first detent for low speed wiper or to the second detent for high speed wiper. Rotate the knob counterclockwise to turn the wiper off. Pushing the knob sprays washer fluid on the windshield to clean the window.

2. Upper Lights Switch



This switch operates upper floodlights. Push the right side of the switch to turn floodlights on, left side to turn them off.

3. Boom Floodlight Switch (If Equipped)



This switch operates the boom floodlight. Push the right side of the switch to turn floodlight on, left side to turn it off.

Operator's Manual

4. Rotating Beacon or Strobe Light Switch (If Equipped)



This switch controls the operator's cab rotating beacon or strobe light. Push the right side of the switch to turn it on, left side to turn it off.

5. Gauge Lights Dimmer Switch

This switch is used to control the dash lights. Rotate the switch right to dim the dash lights or rotate left to brighten dash lights.

6. First Layer/Third Wrap Calibration Switches (If Equipped)



These switches are used to calibrate the first layer/third wrap warning system. When the winch wire rope is down to the first layer on the drum(s), an audible alarm will sound intermittently, and "First Layer" will appear in the warning message area on the RCL

Display to alert the operator that the wire rope is down to the first layer on the winch drum(s). When the wire rope is down to the third wrap on the winch drum(s), an audible alarm will sound continuously, and "Third Wrap" will appear in warning message area on the RCL Display. If enabled and activated, the winch function will also cutout with the third wrap alarm. Refer to First Layer/Third Wrap Calibration in Section 3 of this Operator's Manual for calibration procedures.

7. Function Lockout Switch



This switch is used to disable hydraulic functions which are operated by the control levers and boom telescope foot pedal.

Press the right side of the switch to disable hydraulic functions and to prevent inadvertent operation of these controls. To allow normal operation of the control levers and boom telescope foot pedal, press the left side of the switch. The right side of the switch will illuminate to indicate the switch is in the ON position.

8. 12V DC Accessory Outlet

Use this outlet for electrical accessories.

9. Horn Button



Press this button to sound the horn. Before starting the engine, it is recommended to sound the horn twice in succession and wait 10–15 seconds while making a visual check to verify that there are no persons under or in close proximity to the crane. There also is a horn button on the right control lever.

10. Key On Indicator

This indicator will illuminate to alert the operator that the ignition key is in the ON position.

11. Engine Ignition Switch

The engine ignition switch is the conventional, key operated, automotive type. It controls engine off/on/start, accessories, and energizes the instrument panel in the operator's cab.

12. Engine Emergency Shutdown Button



The engine emergency shutdown button is used to shutdown the engine in emergency situations. Press the button to shutdown the engine. Reset the button by turning it counterclockwise.

13. Rated Capacity Limiter (RCL) Display

This displays the boom length, boom angle, load weight, etc. Refer to "Crane Monitoring System" in this Section of this Operator's Manual for complete operating instructions.

14. Remote Boom Floodlight Controls (If Equipped)



Use the rocker switch to operate the boom floodlight. Push the top part of the switch to turn floodlight on, bottom part to turn it off. Use the directional control to move the floodlight up, down, left, or right.

15. Crane Control Display

The Crane Control Display will display various carrier engine data such as rpm's, coolant temperature, fuel level, etc. Refer to "Crane Control Display" in this Section of this Operator's Manual for operating instructions.

CAUTION

Do not connect an accessory to any part of the crane other than the accessory outlets or cigarette lighter. Major damage to the crane's electrical system may result. If it is necessary to do so, contact your Link-Belt Distributor.

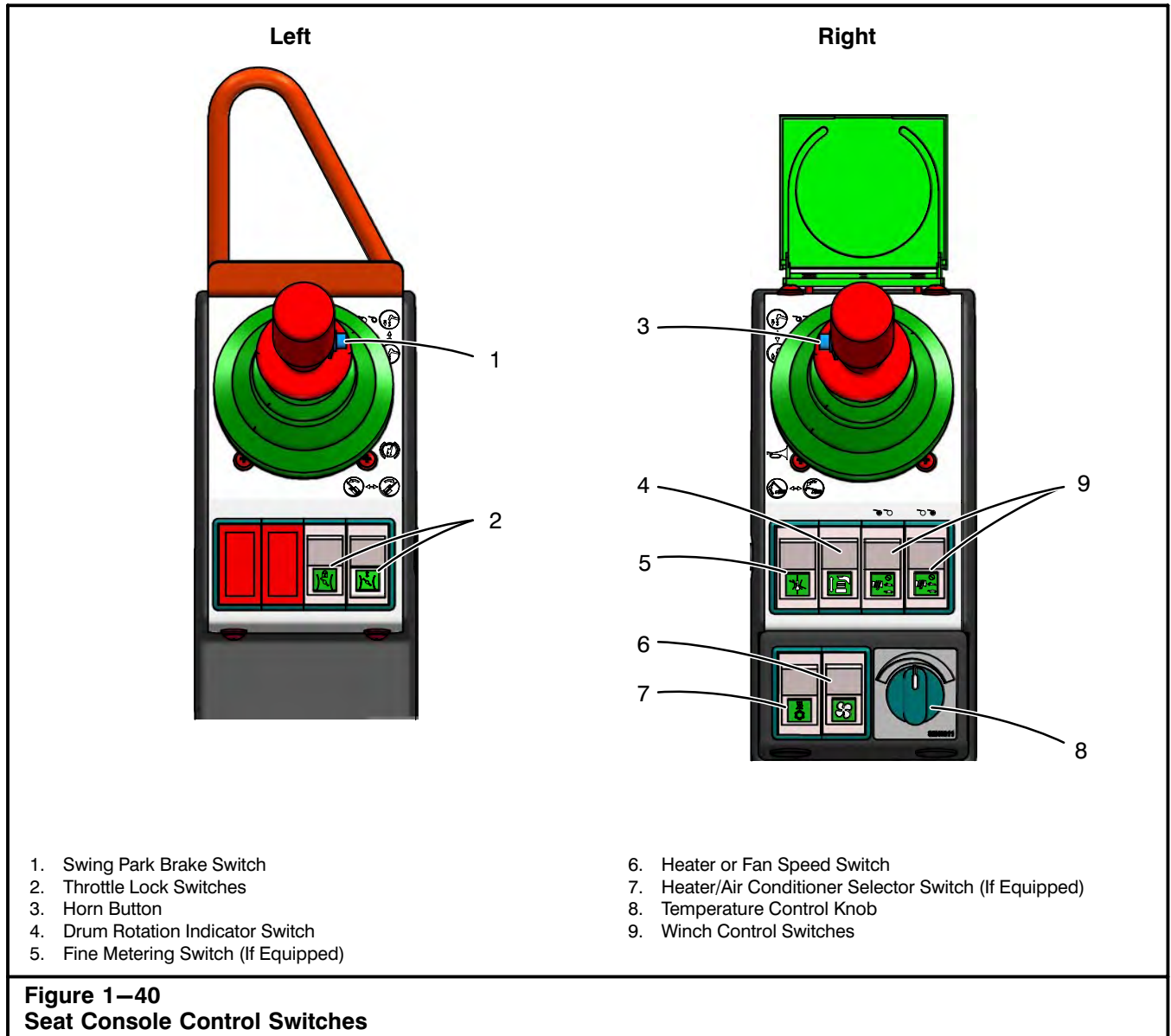

Seat Console Control Switches

Control switches are on the left and right consoles of the operator's seat. Refer to Figure 1-34 and Figure 1-40.

1. Swing Park Brake Switch



This switch is used to operate the swing park brake to hold the upper in any position over the carrier. The Swing Park Brake Indicator Light on the crane control display will illuminate to indicate the swing park brake is applied. Refer to "Swing System" in this Section of this Operator's Manual for complete operating procedures.

2. Throttle Lock Switches



These switches are used to hold the engine at a constant speed. This provides the operator with more flexibility for certain job requirements. Refer to "Throttle Lock System" in this Section of this Operator's Manual.



3. Horn Button



Press this button to sound the horn.

Operator's Manual

4. Drum Rotation Indicator Switch



This switch is used to activate the drum rotation indicator system. To activate the system, press the bottom part of the switch. Press the top part of the switch to deactivate the system. The bottom part of the switch will illuminate to indicate switch is in the ON position. Refer to “Drum Rotation Indicators” in this Section of this Operator's Manual for complete operating procedures.

5. Fine Metering Switch (If Equipped)



This switch is used to activate the fine metering system. Refer to “Fine Metering System” in this Section of this Operator's Manual.

6. Heater or Fan Speed Switch



This switch controls the cab heater if cab is not equipped with air conditioning. Press the top part of the switch to turn the unit on, bottom part to turn it off. If cab is equipped with air conditioning, this switch controls the fan speed.

7. Heater/Air Conditioner Selector Switch (If Equipped)



If cab is equipped with air conditioning and heater, this switch selects which system to operate. Press the top part of the switch to turn the heater on, bottom part to turn the air conditioning on.

8. Temperature Control Knob

Turn the temperature control knob to adjust the temperature in the cab.

9. Winch Control Switches



These switches are used to control engaging/disengaging the high speed hoist and disabling the front and/or rear winch. Refer to “Wire Rope Winch System” in this Section of this Operator's Manual for complete operating procedures.

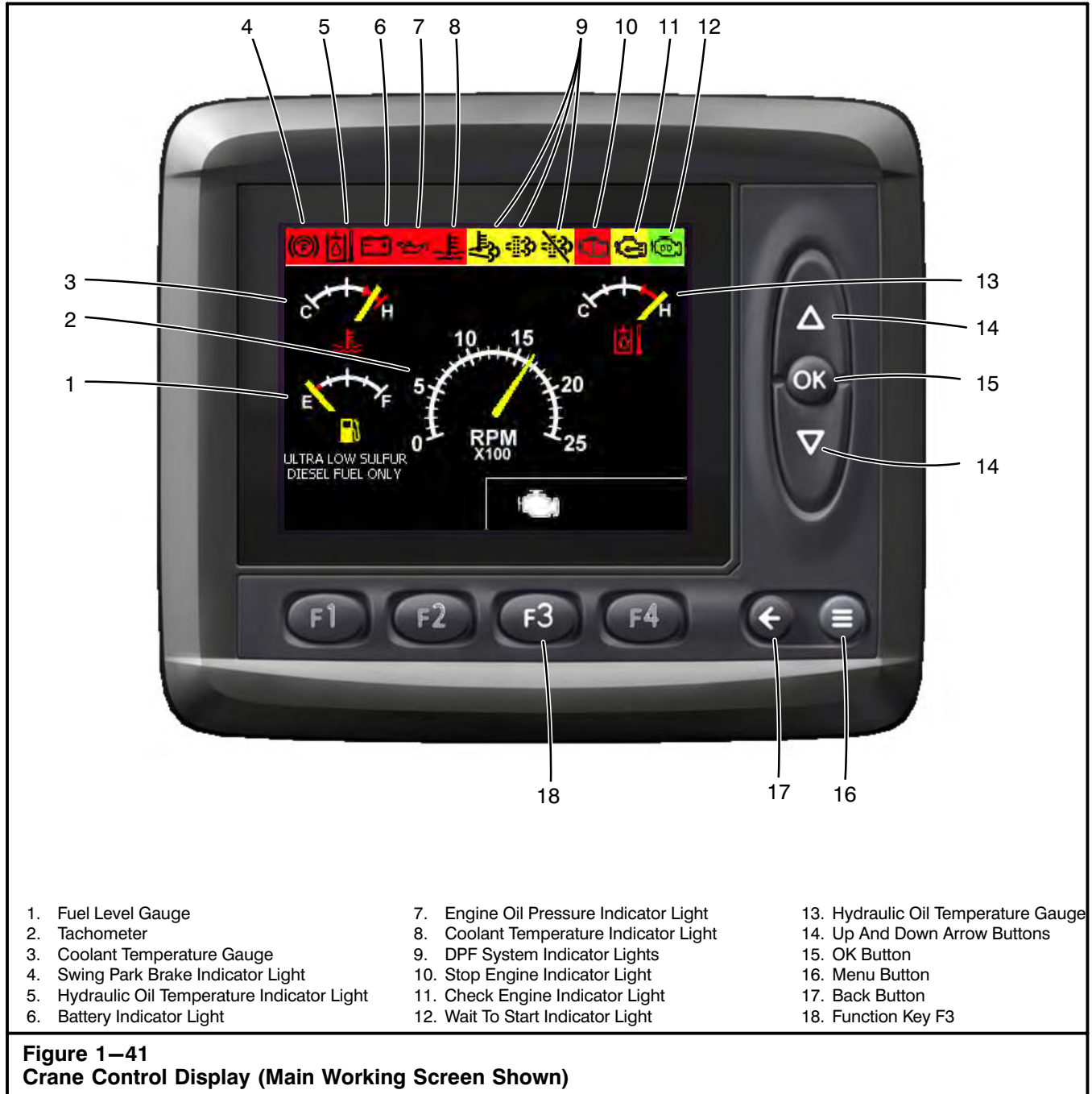

- | | | |
|--|--|-------------------------------------|
| 1. Fuel Level Gauge | 7. Engine Oil Pressure Indicator Light | 13. Hydraulic Oil Temperature Gauge |
| 2. Tachometer | 8. Coolant Temperature Indicator Light | 14. Up And Down Arrow Buttons |
| 3. Coolant Temperature Gauge | 9. DPF System Indicator Lights | 15. OK Button |
| 4. Swing Park Brake Indicator Light | 10. Stop Engine Indicator Light | 16. Menu Button |
| 5. Hydraulic Oil Temperature Indicator Light | 11. Check Engine Indicator Light | 17. Back Button |
| 6. Battery Indicator Light | 12. Wait To Start Indicator Light | 18. Function Key F3 |

Figure 1-41
Crane Control Display (Main Working Screen Shown)

Crane Control Display

The Crane Control Module And Display contains the following controls, gauges, and indicators and is on the Crane Control Console. Refer to Figure 1-39 and Figure 1-41.

1. Fuel Level Gauge



This gauge registers the level of fuel in the fuel tank. The fuel tank capacity is 110 gal (416L). Refer to the engine manufacturer's manual for the correct grade of diesel fuel. When the fuel level

reaches an eighth of a tank, the indicator light within the gauge will change from white to yellow.

2. Tachometer



The tachometer registers engine speed in revolutions per minute (rpm). Refer to the engine manufacturer's manual for suggested operating speeds.

Operator's Manual

3. Coolant Temperature Gauge



This gauge registers the engine cooling system temperature. For proper cooling system operating temperature range, refer to the engine manufacturer's manual. If the cooling system overheats, reduce engine speed until the temperature returns to normal operating range. If engine temperature does not return to normal temperature, refer to engine manufacturer's manual. When the coolant temperature exceeds normal operating range an indicator light will illuminate, an alarm buzzer will sound, and the stop engine indicator light will illuminate. Also the indicator light within the gauge will change from white to red.

4. Swing Park Brake Indicator Light



This light will illuminate anytime the swing park brake is applied and the ignition is on.

5. Hydraulic Oil Temperature Indicator Light



This red indicator light will illuminate along with an alarm buzzer to alert the operator that the hydraulic oil exceeds the maximum operating temperature. If the system overheats, shutdown the crane immediately and correct the problem.

6. Battery Indicator Light



This red indicator light will illuminate along with an alarm buzzer to alert the operator that the charge or the voltage in the battery is not within normal operating range.

7. Engine Oil Pressure Indicator Light



This red indicator light will illuminate along with an alarm buzzer to alert the operator that the engine oil pressure is not within normal operating range. For proper oil pressure operating range, refer to the engine manufacturer's manual. If there is no engine oil pressure after 10–15 seconds of running time, shutdown the engine immediately and repair the problem to avoid engine damage.

8. Coolant Temperature Indicator Light



This red indicator light will illuminate along with an alarm buzzer to alert the operator that the engine cooling system temperature exceeds the maximum operating temperature. For proper cooling system operating temperature range, refer to the engine manufacturer's manual. If the cooling system overheats, reduce engine speed until the temperature returns to normal operating range. If engine temperature does not return to normal temperature, refer to engine manufacturer's manual. When the coolant temperature exceeds normal operating range, the stop engine indicator light will also illuminate.

9. DPF System Indicator Lights



These indicator lights will illuminate during various DPF operations. Refer to "Diesel Particulate Filter (DPF)" in this Section of this Operator's Manual.

10. Stop Engine Indicator Light



This red indicator light will illuminate along with an alarm buzzer and an error message pop-up screen to alert the operator of major engine problems. When this light illuminates stop operations immediately and shutdown the engine. Refer to the engine manufacturer's manual and determine the problem before any further operation of the engine.

11. Check Engine Indicator Light



This yellow indicator light will illuminate along with an error message pop-up screen to make the operator aware of minor engine problems. When this light illuminates engine operation may continue. However, refer to the engine manufacturer's manual and determine the problem as soon as possible to avoid prolonged operation of the malfunctioning engine which could develop into a major problem.

Operator's Manual

12. Wait To Start Indicator Light



This green indicator light will illuminate in cold weather when the ignition switch is in the "ON" position to alert the operator not to crank the engine. During cold weather conditions the light illuminates and an engine air intake heater will activate to heat the air before entering the engine air intake. When the air intake is warm enough the indicator light will go out and then the engine can be started. This aids in engine start-up in cold weather conditions and reduces white smoke after starting. For additional information refer to "Cold Engine Starting" in this Section of this Operator's Manual.

13. Hydraulic Oil Temperature Gauge



This gauge registers the hydraulic oil temperature in the main return line. Normal operating ranges vary with the oils used in different climates. Refer to Section 2 of this Operator's Manual for proper oil viscosities and operating temperature ranges. If the hydraulic oil exceeds the maximum operating temperature, the hydraulic oil temperature indicator light will illuminate and an alarm buzzer will sound. Also the indicator light within the gauge will change from white to red. If the system overheats, shutdown the crane immediately and correct the problem.

14. Up And Down Arrow Buttons



These are navigation buttons that are used to scroll through selections on a menu page.

15. OK Button



Pushing this button equals "enter". Saves the value or confirms the selection.

16. Menu Button



Push this button to bring up a menu page.

17. Back Button



Push this button to return to the previous display page.

18. Function Key F3



This Function Key will bring up the engine data and aftertreatment control screen. Refer to "Engine Data And Aftertreatment Control Screen" in this Section of this Operator's Manual.

Operator's Manual



1. Fuel Consumption
2. Engine RPM
3. Engine Oil Temperature
4. Coolant Temperature
5. Battery Voltage Output
6. Engine Load
7. Function Key F2 – DPF Regeneration Inhibit Switch
8. Function Key F1 – DPF (Parked) Manual Regeneration Switch

Figure 1–42
Engine Data And Aftertreatment Control Screen

Engine Data And Aftertreatment Control Screen

The engine data and aftertreatment control screen can be displayed by pressing the function key F3 (☰) from the main working screen. The display will now show the Engine Data And Aftertreatment Control screen. Press the back button (←) to return to the previous screen. The following describes the data displayed on the engine data and aftertreatment control screen.

1. Fuel Consumption



This displays the actual fuel consumption in gallons per hour (gal/hr).

2. Engine RPM



This displays the actual engine speed in revolutions per minute (rpm). Refer to the engine manufacturer's manual for suggested operating speeds.

3. Engine Oil Temperature



This displays the actual engine oil temperature in degrees Fahrenheit (°F). For proper oil temperature operating range, refer to the engine manufacturer's manual.

Operator's Manual

4. Coolant Temperature



This displays the actual engine cooling system temperature in degrees Fahrenheit (°F). For proper cooling system operating temperature range, refer to the engine manufacturer's manual.

5. Battery Voltage Output



This displays the actual voltage output from the battery in volts (V).

6. Engine Load



This displays the actual engine load as a percentage (%).

7. Function Key F2 – DPF Regeneration Inhibit Switch



The DPF Regeneration Inhibit switch declines an Active and a (parked) Manual Regeneration until turned off. Refer to “Diesel Particulate Filter (DPF)” in this Section of this Operator's Manual.

8. Function Key F1 – DPF (Parked) Manual Regeneration Switch



This switch initiates a (parked) Manual Regeneration. This switch will be active only when the DPF Regeneration Indicator Light illuminates. Refer to “Diesel Particulate Filter (DPF)” in this Section of this Operator's Manual.

Operator's Manual

Crane Control Display Brightness Adjustment



1. From the main working screen, press the menu button.



4. Press the Function Key F2 to select Backlight.



2. Press the Function Key F3 to bring up the Preferences screen.



5. Press the Up/Down Arrow buttons to adjust the display brightness.
6. Press the Function Key F1 to return to the main working screen.



3. Press the Function Key F1 to bring up the Display screen.

Engine Diesel Particulate Filter (DPF)

The diesel particulate filter (DPF) is designed to remove diesel particulate matter or soot from the exhaust gas of the engine. The filter must be periodically regenerated to remove the soot from the filter. During normal operation, the accumulated soot in the DPF will be purged by an automatic regeneration cycle. In some cases an automatic regeneration may not occur and the regeneration cycle must be initiated manually.

Refer to engine manufacturer's manual for additional information on the regeneration process and procedures.

Engine DPF Regeneration Indicators



1. The DPF regeneration indicator light will illuminate to alert the operator that an active regeneration of the diesel particulate filter is required but cannot occur. When this light illuminates, ensure the regeneration inhibit switch is off (regeneration inhibit indicator light is off), increase engine load/speed to allow the engine to run until regeneration is complete, or use the engine DPF regeneration switch to initiate a (parked) manual regeneration cycle as soon as safely possible. Press the Function Key F2 OK button to return to previous screen.



2. The DPF regeneration light begins to flash alerting the operator that the soot loading in the DPF is nearly full. When this light illuminates, ensure the regeneration inhibit switch is off (regeneration inhibit indicator light is off), increase engine load/speed to allow the engine to run until regeneration is complete, or use the engine DPF regeneration switch to initiate a (parked) manual regeneration cycle as soon as safely possible.



3. The DPF regeneration light continues to flash and the check engine light will illuminate to alert the operator that the soot loading in the DPF is full. This condition alerts the operator that the soot loading in the DPF has reached a critical level where a (parked) manual regeneration must be performed immediately and that engine power will be reduced. Press the Function Key F2 OK button and initiate a (parked) manual regeneration. Refer to "DPF (Parked) Manual Regeneration" in this Operator's Manual.



4. The stop engine light will illuminate to alert the operator that the soot loading in the DPF has reached a critical level and continued operation could result in damage to the DPF. Stop the engine as soon as possible and call for service or risk damage to the DPF.

Operator's Manual

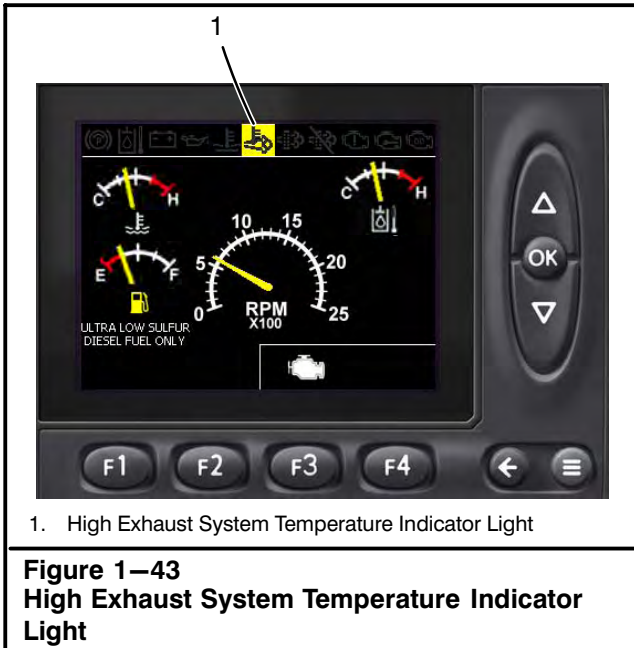

High Exhaust System Temperature Indicator Light

This indicator light will illuminate to alert the operator that the outlet temperature in the engine exhaust system is above normal. This condition can occur under normal operation or during an automatic or manual DPF regeneration cycle. No action is required.



DANGER

The temperature of the engine exhaust gas and the exhaust system components can reach up to 1,200°F (650°C) during DPF regeneration. An unexpected failure of the engine or regeneration system may increase exhaust gas temperature at the particulate exhaust filter to as high as 1,650°F (900°C). This may result in fire, burn, or explosion hazards, which may result in serious personal injury or death. Do not expose flammable material or explosive atmospheres to exhaust gas or to exhaust system components during DPF regeneration.

Engine DPF Regeneration Inhibit Switch

The engine DPF regeneration inhibit switch disables any automatic or manual regeneration of the engine diesel particulate filter. It may be used to prevent any regeneration when the crane is operating in a hazardous environment and there is a concern about high temperatures from the DPF system.



1. To access the DPF Regeneration Inhibit Switch, press the Function Key F3 from the main working screen.



2. The screen will change to the engine data and aftertreatment control screen. From this screen, press the Function Key F2 DPF Regeneration Inhibit Switch to toggle the inhibit function on and off.

Operator's Manual



3. If additional information is required, press the Function Key F4 Help to access a help pop-up menu.



4. If help pop-up menu was accessed, press Function Key F2 OK to exit help pop-up and return to previous screen.



5. If regeneration inhibit is not desired at this time, press Function Key F3 To to exit the Regeneration Inhibit Confirmation pop-up menu and return to previous screen.



6. Press the Function Key F2 Yes to confirm and activate the Regeneration Inhibit. The Regeneration Inhibit indicator light will illuminate to alert the operator that the DPF system is inhibited.
7. Press the back button to return to the main working screen. An indicator light will illuminate to alert the operator that the DPF system is inhibited.

Operator's Manual

DPF (Parked) Manual Regeneration

The DPF manual regeneration switch is used to start a manual regeneration only when the DPF regeneration light is illuminated.

Note: The crane must remain stationary for approximately 45 minutes to complete an engine DPF (parked) manual regeneration.

1. Park the crane in a safe location and apply the swing park brake.
2. Engine must be at minimum operating temperature of 140°F (60°C).



3. To access the DPF Manual Regeneration Switch, press the Function Key F3 to enter the engine data and aftertreatment control screen.



4. The screen will change to the engine data and aftertreatment control screen. From this screen, press the Function Key F1 Manual Regeneration switch to access the Manual Regeneration Confirmation pop-up menu.

Note: Do not press the engine throttle pedal during a DPF manual regeneration cycle. Pressing the engine throttle pedal will deactivate the regeneration cycle and the engine will return to idle. The engine DPF manual regeneration cycle must be restarted.



5. If additional information is required, press the Function Key F4 Help to access a help pop-up menu.



6. If help pop-up menu was accessed, press Function Key F2 OK to exit help pop-up and return to previous screen.

Operator's Manual



7. If a manual regeneration is not desired at this time, press Function Key F3 No to exit the Manual Regeneration Confirmation pop-up menu and return to previous screen.



8. Press the Function Key F2 Yes to confirm and initiate a manual regeneration cycle.

The engine ECM will perform a system check for approximately 30 seconds before starting the engine DPF manual regeneration cycle; also, the engine speed will increase to 1,000–1,400 rpm. When the cycle begins, the engine DPF regeneration indicator light goes out. When engine DPF regeneration is complete, the upper engine will return to idle and the exhaust temperature indicator light goes out.



DANGER

The temperature of the engine exhaust gas and exhaust system components can reach up to 1,200° F (650° C) during DPF regeneration. An unexpected failure of the engine or regeneration system may increase exhaust gas temperature at the particulate exhaust filter to as high as 1,650° F (900° C). This may result in fire, burn, or explosion hazards, which may result in serious personal injury or death. Do not expose flammable material or explosive atmospheres to exhaust gas or to exhaust system components during DPF regeneration.

Operator's Manual

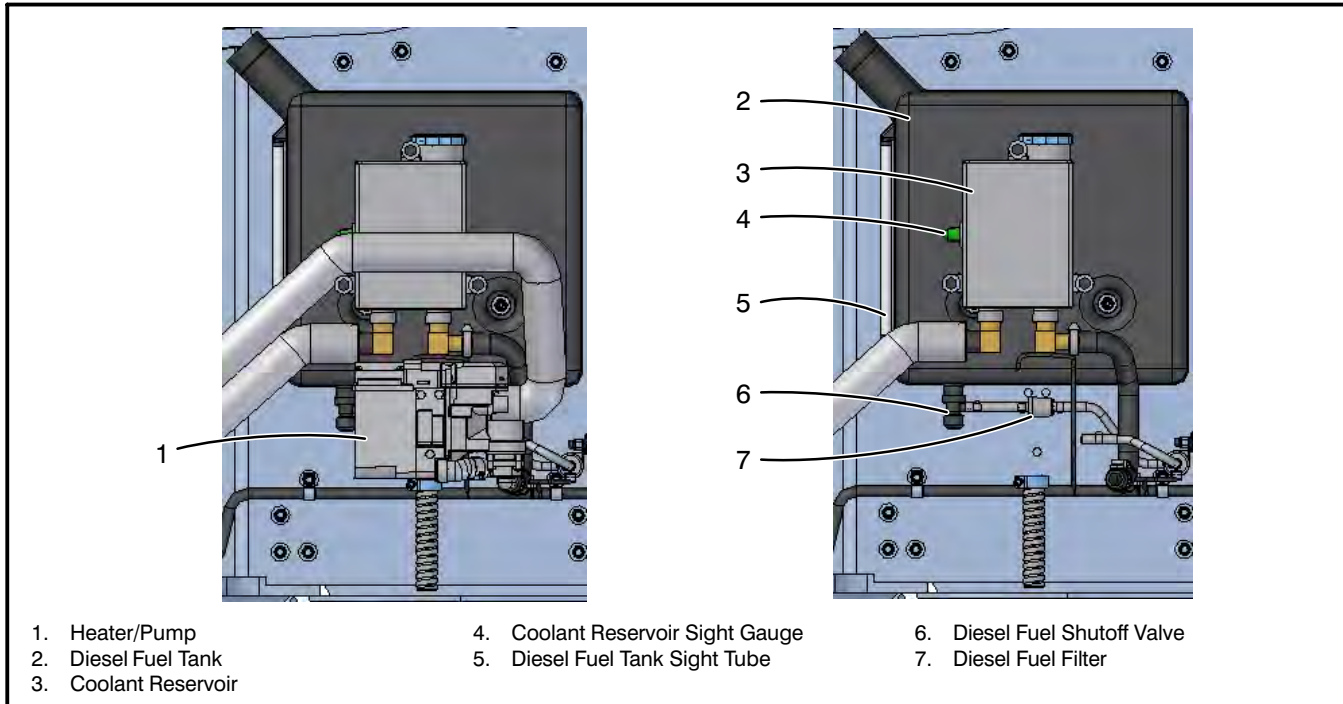

Figure 1-44
Diesel Fired Warm-water Cab Heater

Cab Heater Operation



This crane may be equipped with a diesel fired warm-water cab heater or an optional engine dependant warm-water cab heater. Refer to the following instructions to operate the cab heater that is used on the crane.

Diesel Fired Warm-water Cab Heater

This cab heater uses antifreeze circulating through the unit to provide heat. antifreeze is stored in a reservoir mounted on the left side of the upper revolving frame. This antifreeze is heated by a diesel fired heater/pump and circulated through the heat exchanger in the cab. The diesel fuel tank, for the system, is mounted on the left side of the upper revolving frame. Refer to Figure 1-44. Diesel fuel should be #1, #2, or arctic. The fuel system is equipped with an inline filter and should be changed every 2,000 hours of operation or annually, whichever occurs first. The antifreeze used should be the same type used in the crane's engine. Refer to engine manufacturer's manual for proper anti-freeze selection.

Note: Operate the heater at least once a month for 10 minutes.

Note: To improve heater performance when operating the crane in prolonged ambient temperatures below -7°C (20°F), kerosene is the recommended fuel.

| | |
|---|---|
|  |  WARNING |
| | <p>Diesel exhaust fumes can be harmful. Start and operate diesel cab heater in a well ventilated area. If it is necessary to operate in an enclosed area, vent the exhaust to the outside.</p> |

To Start The Diesel Fired Warm-water Cab Heater

1. Before activating the heater, ensure that the diesel fuel tank and the coolant reservoir are full.
2. With the engine running, press the heater switch or if crane is equipped with air conditioning, press the top part of the heater/air conditioner selector switch to turn the heater on. Refer to Figure 1-40.
3. Turn the temperature control knob to the desired setting.
4. If cab is equipped with air conditioning, use the fan speed switch to control the air flow into the cab. If cab is not equipped with air conditioning, use the heater/fan speed switch to control the air flow into the cab.

To Stop The Diesel Fired Warm-water Cab Heater

1. Press the heater switch to the off position.
2. During warm weather conditions or if the heater is not going to be used for an extended period of time, rotate the temperature control knob to the coolest setting.

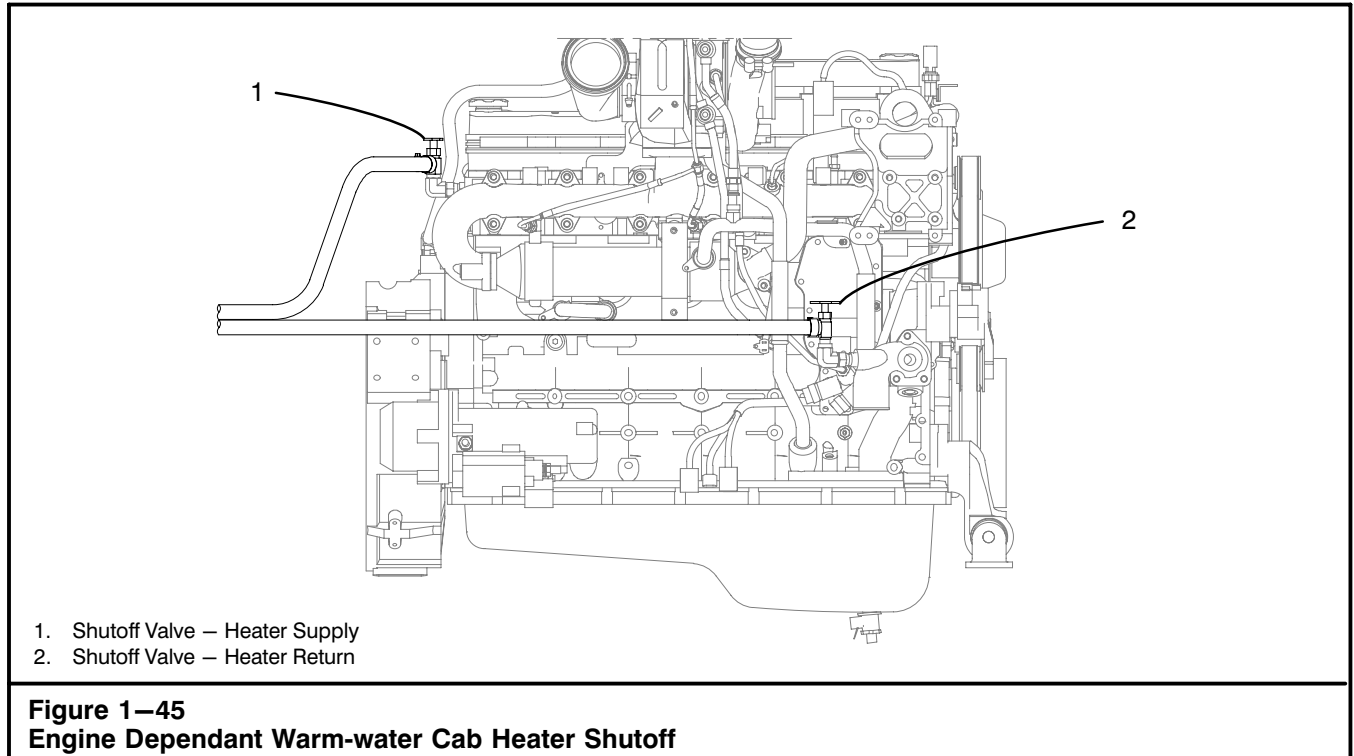

Engine Dependant Warm-water Cab Heater (If Equipped)

This cab heater uses engine coolant circulating through the unit to provide heat. Normally the engine coolant circulates through the heater in the cab regardless of whether the heater switch is turned on or not. During warm weather conditions, the operator may wish to shutoff the flow of hot engine coolant to the heater to reduce the temperature in the cab. Shutoff valves are on the engine to perform this function. Refer to Figure 1–45.

To Start The Cab Heater

1. With the engine running, press the heater switch or if crane is equipped with air conditioning, press the top part of the heater/air conditioner selector switch to turn the heater on. Refer to Figure 1–40.
2. Turn the temperature control knob to the desired setting.
3. If cab is equipped with air conditioning, use the fan speed switch to control the air flow into the cab. If cab is not equipped with air conditioning, use the heater/fan speed switch to control the air flow into the cab.

To Stop The Cab Heater

1. Press the heater switch to the off position.
2. During warm weather conditions or if the heater is not going to be used for an extended period of time, rotate the temperature control knob to the coolest setting.

Cab Heater Shutoff (If Equipped)



Shutdown the engine and allow it to cool before operating the heater shutoff valves. The valves may be hot and could cause serious burns.

1. Shutdown the engine and rotate the handles on the shutoff valves clockwise to stop the flow of engine coolant to the heater; Counterclockwise to restore it. Refer to Figure 1–45.

Air Conditioning (If Equipped)

The operator's cab may be equipped with an air conditioning unit. Use the following instructions to operate the unit. Refer to Figure 1–40.

1. Start the engine and allow all operating temperatures and pressures to reach their normal range.
2. Press the bottom part of the heater/air conditioner selector switch to activate the air conditioning unit.
3. Press the fan speed switch to control the amount of air blown into the cab.
4. Turn the temperature control knob to the desired setting.
5. To turn the unit off, press the heater/air conditioner selector switch to the off position.

Operator's Manual

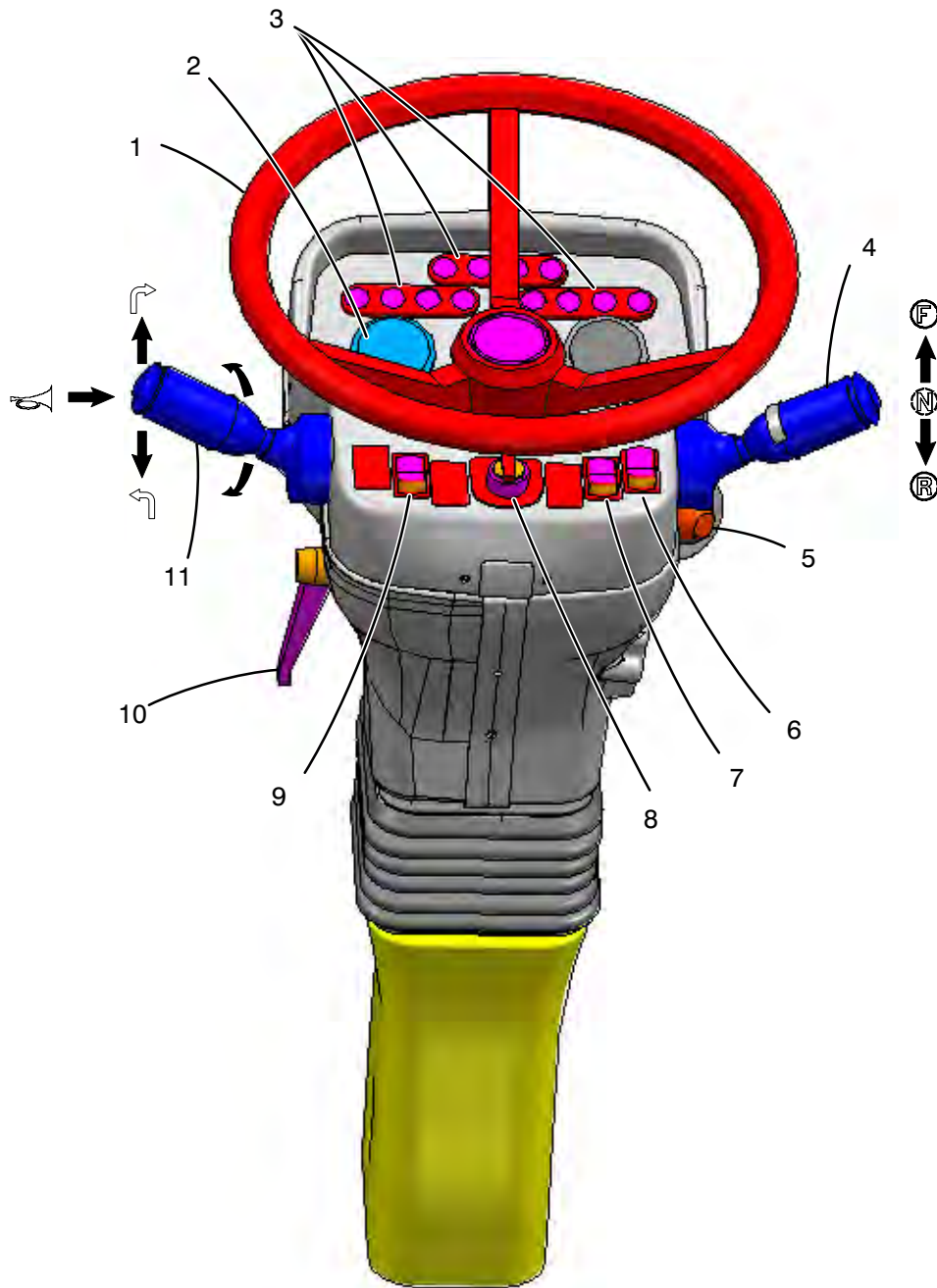

- | | | |
|---------------------------------------|--------------------------------|---|
| 1. Steering Wheel | 5. Emergency Hazard Switch | 9. Travel Park Brake Switch |
| 2. Transmission Oil Temperature Gauge | 6. Transmission Gear Switch | 10. Tilt/Telescoping Column Lever |
| 3. Indicator Light Bars | 7. 4-Wheel Drive/Range Switch | 11. Turn Signal/Horn/Driving Lights Lever |
| 4. Transmission Shift Lever | 8. Combination Steering Switch | |

Figure 1-46
Steering Column And Wheel

Steering Column And Wheel

The following is a description of the controls on the steering column along with an explanation of their function and/or operation. Refer to Figure 1–46.

1. Steering Wheel

Turn the steering wheel clockwise for right turns and counterclockwise for left turns.

Note: Relative direction of the steering wheel is based on the position of the upper over the carrier.

2. Transmission Oil Temperature Gauge



This gauge registers the oil temperature in the transmission torque converter. Normal operating temperature range is 180–210°F (82–98°C). When the oil temperature exceeds normal operating range an indicator light within the gauge will illuminate and an alarm buzzer will sound. If the oil overheats, discontinue operation, shift the transmission to neutral, and run the engine at 1,000–1,200 rpm (do not stop the engine if the cooling system is known to be in working order). Transmission oil temperature should soon lower. Always change the oil and filter after the transmission oil has overheated. Refer to Section 2 of this Operator's Manual for the correct oil change procedure.

3. Indicator Light Bars

Three indicator light bars are on the steering column and contain the following indicator lights:



Left Turn Signal – This light will blink to indicate that the left turn signal is on or the hazard lights are flashing.



Engine Oil Pressure – This indicator light will illuminate when the engine oil pressure is not within normal operating range. If there is no engine oil pressure after 10–15 seconds of running time, shutdown the engine immediately and repair the problem to avoid engine damage.



Rear Wheel Offset – This indicator light will illuminate to alert the operator that the rear wheels are out of line with the carrier. Refer to “Combination Steering” in this Section of this Operator's Manual for complete operating procedures.



Emergency Steer – On cranes equipped with emergency steer, this light alerts the operator that power steering pump pressure is low. When the emergency steering indicator light illuminates, there is enough oil in storage to negotiate approximately eight 90° turns. Park the crane and shutdown the engine if this indicator light illuminates. Discontinue further operations until the problem is resolved.



Travel Park Brake Engaged – This light will illuminate anytime the park brake is engaged and the ignition is on.



Service Brake Warning – This light will illuminate to warn the operator of an imminent brake failure. When this light illuminates, approximately twelve brake applications can be obtained prior to complete brake system failure. When this light illuminates discontinue operations immediately, park the crane, and correct the problem before placing the crane back into service.



Right Turn Signal – This light will blink to indicate that the right turn signal is on or the hazard lights are flashing.

4. Transmission Shift Lever

The transmission shift lever is used to select the forward or reverse gear in the transmission. To put the transmission in forward or reverse gear, the lever is pushed up then pushed forward to engage the forward gears, or pulled backward to engage the reverse gears.

5. Emergency Hazard Switch

This switch controls the emergency hazard flashers. Push the switch to turn flashers on, push the switch again to turn them off.

6. Transmission Gear Switch

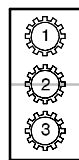

This switch is used to shift the transmission. Press the top part of the switch for first gear, middle position for second gear, and bottom part of the switch for third gear.

Operator's Manual

7. 4-Wheel Drive/Range Switch

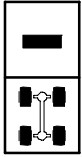

This switch is used to select either the 2-Wheel drive mode or 4-Wheel drive mode for the carrier power train by engaging or disengaging the front drive axle. This switch also simultaneously selects either high or low range speeds for the transmission. When the switch is in the "4-WHEEL DRIVE" mode the transmission is in the low speed range. When the switch is in the "2-WHEEL DRIVE" mode the transmission is in the high speed range. Bring the crane to a complete stop and shift the transmission to neutral before changing the position of the 4-Wheel Drive Switch. The top part of the switch will illuminate to alert the operator that 4-wheel drive mode has been engaged.

8. Combination Steering Switch

The crane is equipped with four different modes of steering in order to provide maximum maneuverability on the job site. Refer to "Combination Steering" in this Section of this Operator's Manual for complete operating procedures.

9. Travel Park Brake Switch



This switch controls engaging and releasing the park brake.



WARNING

Do not use the park brake to stop the crane in motion (as a service brake) except in cases of extreme emergency. Application cannot be controlled.

To Engage Park Brake

- Bring the crane to a complete stop by applying the carrier service brake.
- Shift the transmission to neutral.
- Move park brake switch to "ON" position.
- Park brake indicator light should illuminate.

To Release Park Brake

- Apply the carrier service brake.
- Move park brake switch to the "OFF" position.
- The park brake indicator light should go out.

10. Tilt/Telescoping Column Lever

This lever controls the tilt (angle) and telescoping function of the steering column.



To change steering column height and angle:

- Bring the crane to a complete stop.
- Shift the transmission to neutral and engage the park brake.
- Rotate the tilt/telescoping column lever.
- Position the steering wheel at the desired height and angle and rotate lever to lock it in place.
- Check all steering wheel functions before continuing operation.

11. Turn Signal/Horn/Driving Lights Lever

Turn Signal – Pull the lever down for left turn signal, push up on lever for right turn signal.

Horn – Push the end of the lever to sound the horn.

Driving Lights – Rotate the lever to the first detent  to illuminate the parking lights, the second detent  for headlights. Rotate the lever to the off  position to turn all lights off.

Transmission Controls

The transmission controls are on the steering column. Refer to Figure 1—46. The transmission shift lever controls all functions of the powershift transmission. The transmission contains three forward and three reverse high range speeds in 2-wheel drive mode and three forward and three reverse low range speeds in 4-wheel drive mode. See “Traveling The Crane” in this Section of this Operator's Manual for necessary preparations before traveling the crane.

Shifting The Transmission

1. Engage the park brake and place shift lever in neutral position. Start the engine. (Engine will start only when transmission is in neutral.) Allow the transmission oil temperature to reach normal operating range.
2. Engage travel swing lock and release the swing park brake and the 360° swing lock, if equipped.

CAUTION

Do not leave the swing park brake or 360° swing lock engaged during pick and carry operations or when traveling or transporting the crane. Use the travel swing lock. Failure to release the swing park brake and 360° swing lock during these operations may result in damage to the swing gear.

3. Forward Travel
 - a. With crane at a complete stop, apply the carrier service brakes, shift the transmission to neutral, and release the park brake.
 - b. Move transmission shift lever to the “F” position.

Note: Relative direction of the crane is based on the position of the upper over the carrier.

- c. Slowly release the service brake while using the throttle pedal to increase the engine speed allowing the crane to accelerate.
- d. At full engine speed, press the transmission gear switch to shift to the next gear. Repeat to shift through the desired gears.

4. Reverse Travel
 - a. With crane at a complete stop, apply the carrier service brakes, shift the transmission to neutral, and release the park brake.
 - b. Move transmission shift lever to the “R” position.

Note: Relative direction of the crane is based on the position of the upper over the carrier.

The travel/back-up alarm will sound anytime the transmission is shifted into reverse. It will also sound anytime the transmission is shifted out of neutral and the upper is not positioned directly over the front of the carrier.

- c. Slowly release the service brake while using the throttle pedal to increase the engine speed allowing the crane to accelerate.
- d. At full engine speed, press the transmission gear switch to shift to the next gear. Repeat to shift through the desired gears.

Operator's Manual

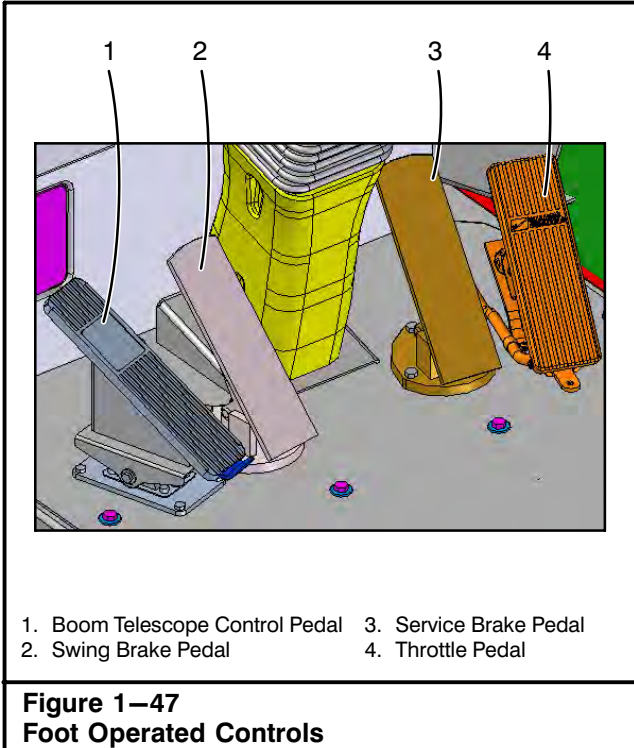

Foot Operated Controls

The following is a description of the foot controls in the operator's cab along with an explanation of their function and/or operation. Refer to Figure 1-47.

1. Boom Telescope Control Pedal

Depress the toe of the pedal to extend the boom. Depress the heel to retract the boom. Refer to "Boom Telescope System" in this Section of this Operator's Manual for complete operating instructions.

2. Swing Brake Pedal

The swing brake pedal is used to stop rotation of the upper over the carrier. Refer to "Swing System" in this Section of this Operator's Manual for complete operating instructions.

3. Service Brake Pedal

The carrier service brakes are controlled by the brake pedal. Press the pedal down to apply the service brakes. Release the pedal to release the service brakes.

The distance the service brake pedal is moved determines the braking force. Depress the pedal fully only in cases of emergency as this makes control of the crane difficult.

4. Throttle Pedal

Engine speed is controlled by the throttle pedal. Press the throttle pedal down to increase engine speed. Release the throttle pedal to decrease engine speed.

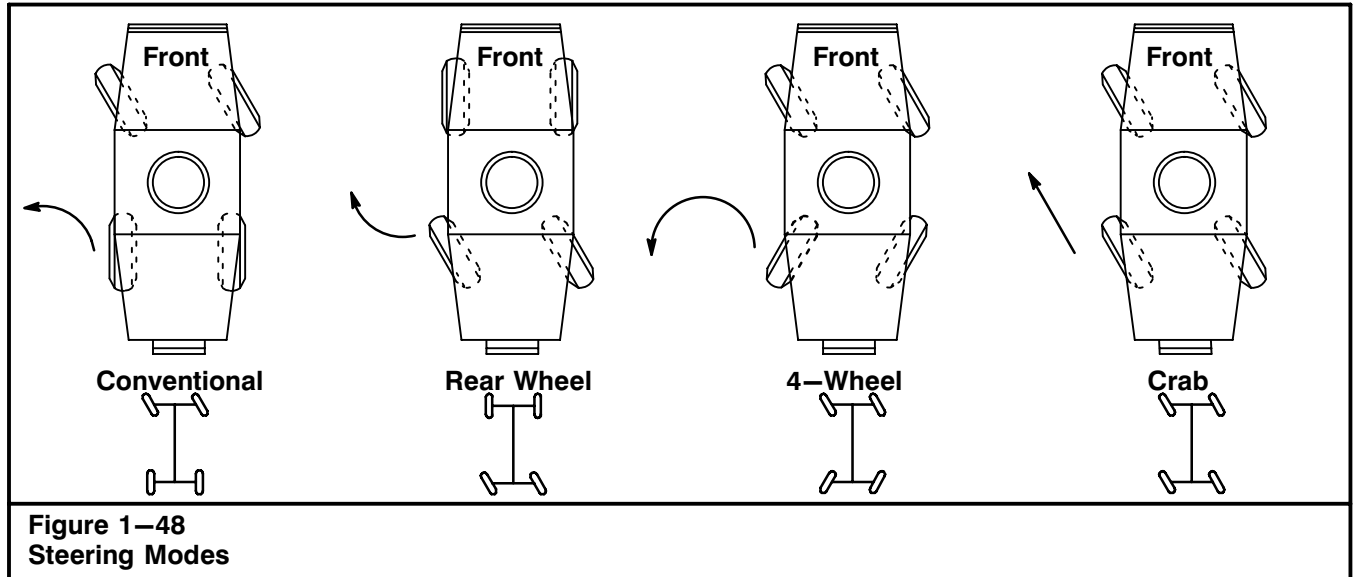

Figure 1-48
Steering Modes

Combination Steering

The crane is equipped with four different modes of steering in order to provide maximum maneuverability on the job site: conventional, rear wheel, 4-wheel, and crab steer. Each steer mode provides slightly different maneuverability to meet job site requirements. Refer to Figure 1-48 for illustration of the different steer modes.

Conventional Steer Mode

This steer mode is similar to that of an automobile. In this steer mode, the front wheels may be turned in either direction and the rear wheels remain stationary. Use this steer mode for all extended or high speed travel.



WARNING

Do not use rear wheel, 4-wheel, or crab steer mode for extended or high speed travel as steering behavior may be unfamiliar and a loss of crane control could occur.

Rear Wheel Steer Mode

This steer mode is similar to that of a fork truck. In this steer mode, the rear wheels may be turned in either direction and the front wheels remain stationary. Use this steer mode for job site travel only; not for extended or highway travel.

4-Wheel Steer Mode

This steer mode allows steering with all four wheels. The front wheels turn in one direction and the rear

wheels turn in the opposite direction. This results in a greatly reduced turning radius that allows extra maneuverability in certain job site conditions. Use this steer mode for job site travel only; not for extended or highway travel.

Crab Steer Mode

This steer mode allows steering with all four wheels. The front and rear wheels turn simultaneously in the same direction which moves the crane in the diagonal path of travel. This gives the operator another method of maneuvering the crane where job site conditions require it. Use this steer mode for job site travel only; not for extended or highway travel.

Changing Steering Modes

The rear wheel offset light, on the steering column in the indicator light bars (Figure 1-46), is designed to assist the operator in changing steering modes by determining when the rear wheels are straight. This light will come on anytime the rear wheels are not in-line with the carrier. Use the following procedure when changing steering modes:

1. Bring the crane to a complete stop.
2. Turn the steering wheel until the rear wheel offset light goes off.
3. Move the steer switch to the conventional steering mode.
4. Check all wheels for proper alignment by traveling the crane a short distance, straight ahead, to ensure it tracks straight.
5. Bring the crane to a complete stop and move the steer mode switch to the desired position.

Operator's Manual

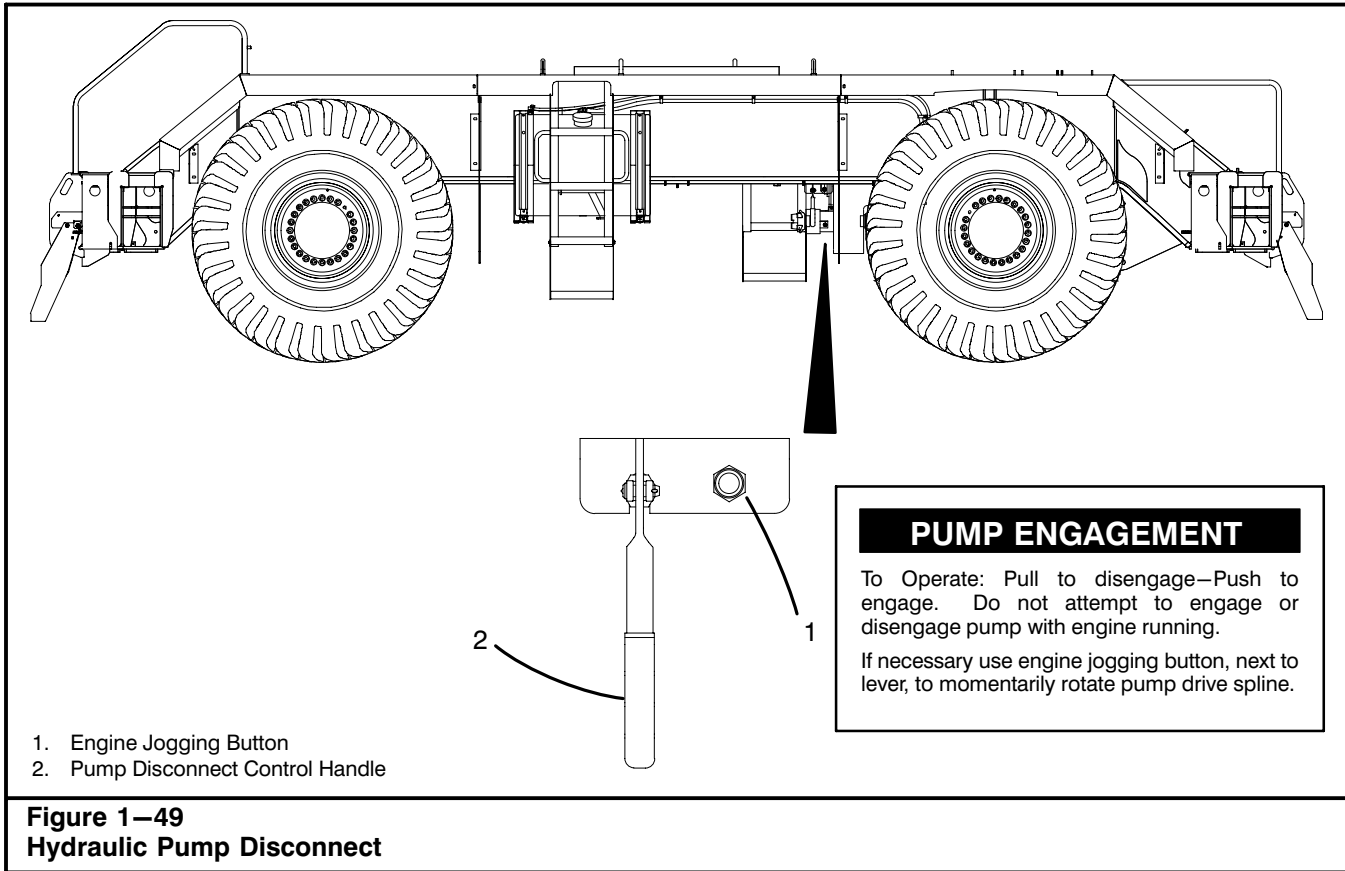

Hydraulic Pump Disconnect (If Equipped)

The hydraulic pump disconnect (if equipped) is used to engage and disengage the main hydraulic pump. Disengaging the main pump aids in engine start-up by reducing cranking resistance. It also allows for disengaging the pump for highway travel. Refer to Figure 1—49.

The crane is equipped with an engine jogging button, beside the disconnect control handle, to aid in engaging the hydraulic pump.

Note: In extremely cold weather, it is recommended that the pump be allowed to cycle without a load for 3–5 minutes at low engine speed. Throttle engine to half throttle and cycle the boom telescope for another 3–5 minutes. This will help prevent cold oil from damaging the main pump.

To Engage The Main Pump

1. Warm up the engine using the normal start-up and warm-up procedure.
2. Park the crane and engage the park brake.

3. Shift the transmission to neutral and shutdown the engine.

CAUTION

Do not attempt to engage or disengage the pump with the engine running. Damage could occur to the pump and/or pump drive.

4. Push the pump disconnect control handle to the limit of its travel. If control handle cannot be pushed to the limit, push and release the engine jogging button and push the handle to the limit again.

To Disengage The Main Pump

1. Park the crane and engage the park brake.
2. Shift the transmission to neutral and shutdown the engine.

CAUTION

Do not attempt to engage or disengage the pump with the engine running. Damage could occur to the pump and/or pump drive.

3. Pull the handle out, to the limit of its travel.

Operator's Seat

This 6-way adjustable seat is controlled by manual controls. Refer to Figure 1–50.



WARNING

Do not make seat or console adjustments while operating the crane or while crane is in motion. Discontinue operations and properly park crane before making adjustments.

1. Seat And Console Release Lever

Move the seat and console release lever to the left and hold. Position the seat as desired and release the lever to lock the seat in place.

2. Seat Release Lever

Move the seat release lever to the left and hold. Position the seat as desired and release the lever to lock the seat in place.

3. Seat Height Adjustment Lever

Move the height adjustment lever to the left and hold. Position the seat as desired and release the lever to lock the seat in place.

4. Arm Rest Height Adjustment Knob

Loosen the knob on the inside of the arm rest. Position the arm rest as desired and tighten knob to lock the arm rest in place.

5. Seat Back Adjustment Lever

Raise the lever and adjust the seat back to the desired position. Release the lever to lock the seat back in place.

6. Seat Belt

A seat belt is provided and must be worn during all operations. To fasten the seat belt pull the belt out of the retractor and insert the tongue into the buckle until you hear a snap and feel the latch engage. Ensure the belt is not twisted and is fitting snugly around the hips, not around the waist.

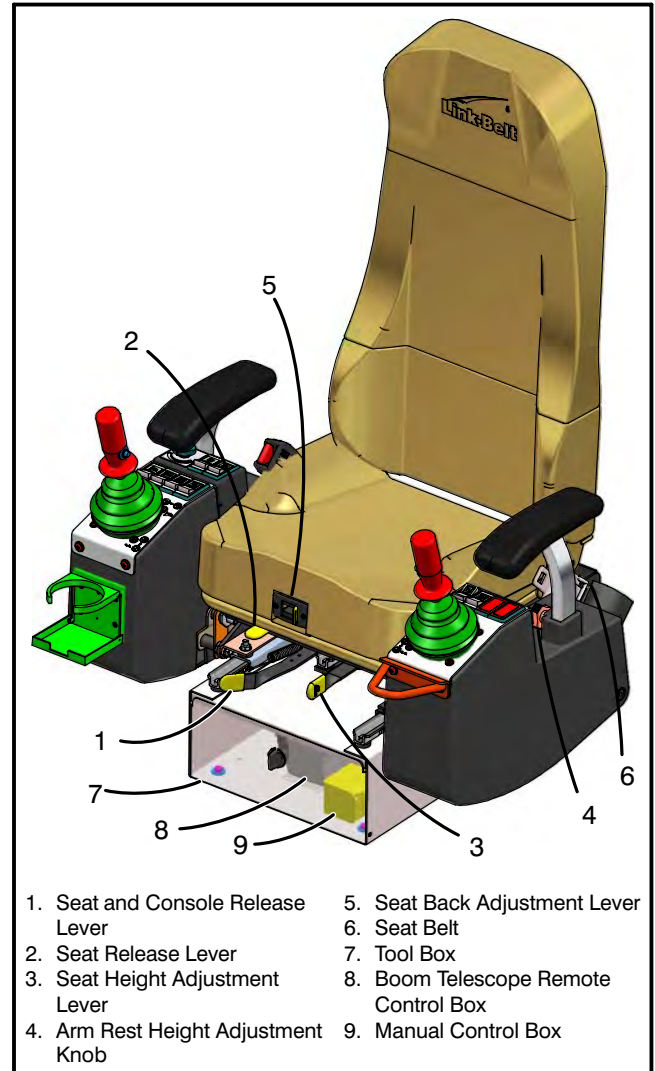

- | | |
|------------------------------------|--------------------------------------|
| 1. Seat and Console Release Lever | 5. Seat Back Adjustment Lever |
| 2. Seat Release Lever | 6. Seat Belt |
| 3. Seat Height Adjustment Lever | 7. Tool Box |
| 4. Arm Rest Height Adjustment Knob | 8. Boom Telescope Remote Control Box |
| | 9. Manual Control Box Knob |

Figure 1–50
Operator's Seat



WARNING

Always wear the seat belt while operating the crane. The seat belt must be snug and low across the hips.

7. Tool Box

A tool box is provided under the operator's seat to store tools and other crane accessories.

Operator's Manual

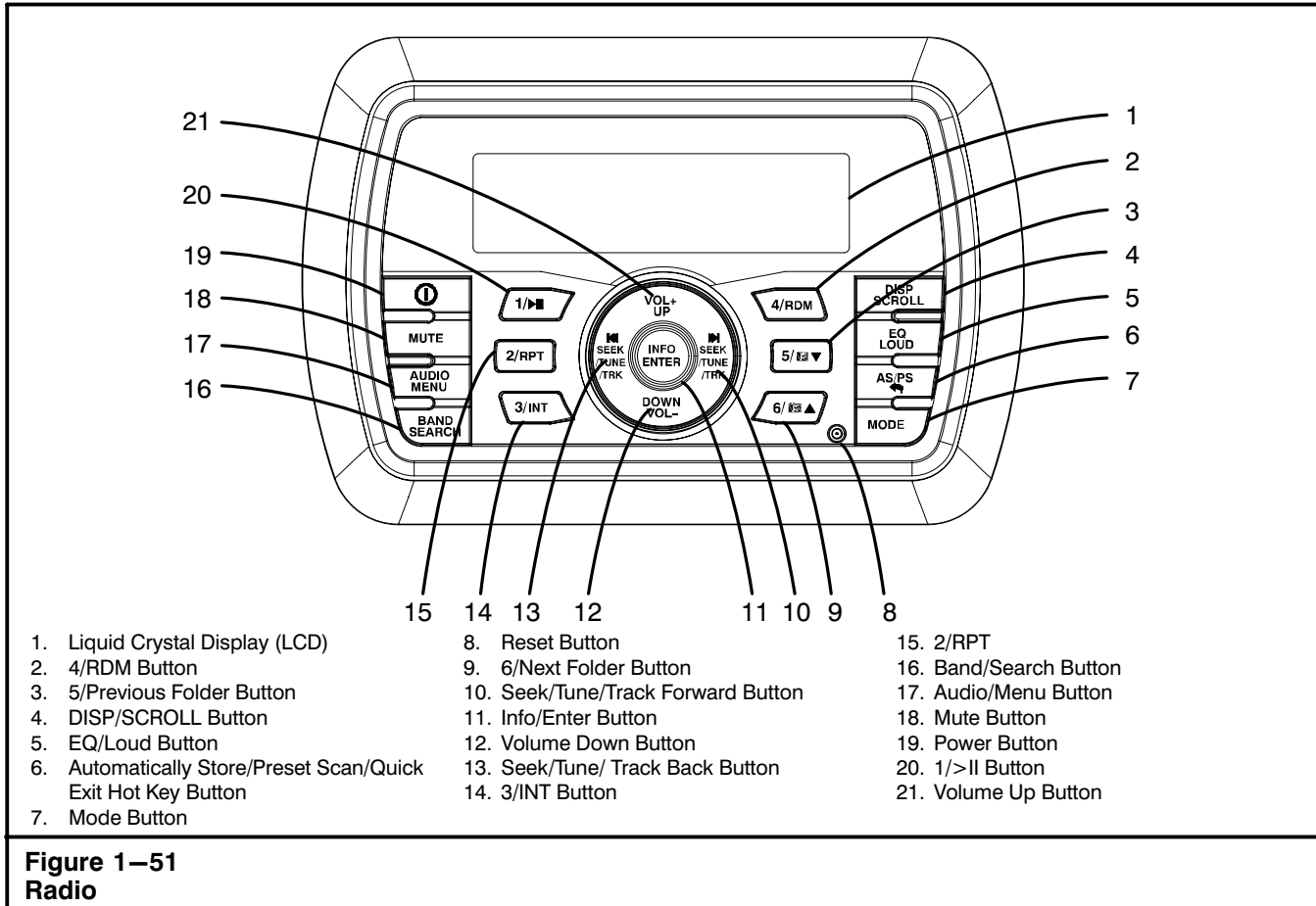

Radio Operation

Note: Keep the volume level low enough to be aware of your surroundings while operating the crane.

The crane may be equipped with an AM/FM radio/audio system. It includes the following features: an AM/FM/EURO tuner with 30 Presets (12 AM and 18 FM), Weather Band with Weather Alert, Bluetooth (Supports A2DP and AVRCP), USB playback of MP3/WMA files, iPod/iPhone USB input, Mute, Preset Equalizer (User, Flat, Pop, Classical, Rock), Electronic Bass, Treble, Balance, and Fade Controls, Output Power (40W x 4), Wired Remote Control Ready, 2 Channel Pre-amp Line Level Outputs, and a Auxiliary Audio Input.

This radio generates, uses, and can radiate radio frequency energy and, if not installed and used in accordance with the instructions, may cause harmful interference to radio communications.

If this radio does cause harmful interference to radio or television reception, which can be determined by turning the radio OFF and ON, the Operator is encouraged to try to correct the interference by one or more of the following measures:

- Relocate the receiving antenna.
- Increase the distance between the radio and receiver.
- Connect the radio into an outlet on a different circuit that to which the receiver is connected.
- Contact your Link-Belt Distributor for the service.

Operator's Manual

1. Liquid Crystal Display (LCD)

The LCD shows the reception frequency and activated functions of the system.

Note: LCD panels may take longer to respond when subjected to cold temperatures for an extended period of time. In addition, the visibility of the numbers on the LCD may decrease slightly. The LCD display will return to normal when the temperature increases to a normal range.

2. 4/RDM Button

Press the 4/RDM Button to go to preset 4. During playback mode, press the 4/RDM Button to play all songs in the current category in random order. Random order will occur once the current song has finished playing. "Random On" will appear on the LCD. Press the 4/RDM Button again to stop random playback.

3. 5/Previous Folder Button

Press the 5/Previous Folder Button to go to preset 5. When navigating folders, press the 5/Previous Folder Button to go to the previous folder and begin playback of the first song in that folder.

4. DISP/SCROLL Button

Press the DISP/SCROLL Button to change the display information from single line default display to Artist/Song Title double line display mode.

5. EQ/Loud Button

Press the EQ/Loud Button to turn on the equalization function and select between five pre-defined bass and treble curves: User, Flat, Pop, Classical, Rock. Press and hold the EQ/Loud Button to toggle true loudness ON/OFF. When listening to music at low volumes, this feature will boost the bass ranges to compensate for the characteristics of human hearing.

6. Automatically Store/Preset Scan/Quick Exit Hot Key Button

Automatically Store

Select an AM or FM band. Press and hold the Automatically Store/Preset Scan/Quick Exit Hot Key Button for more than 2 seconds to automatically select strong stations and store them in all bands. The new stations replace any previous stored stations within the band.

Preset Scan

Select a band if needed. Press the Automatically Store/Preset Scan/Quick Exit Hot Key Button to scan all stations stored in all bands. The system will pause for 10 seconds at each preset station. Press the Automatically Store/Preset Scan/Quick Exit Hot Key Button to stop scanning when the desired station is reached.

Quick Exit Hot Key

While in system menu operation, searching mode, or audio menu operation press and hold the Automatically Store/Preset Scan/Quick Exit Hot Key Button for 3 seconds to quickly exit the operation without waiting for the system default time out.

7. Mode Button

Press this button to toggle between modes. Modes include AM/FM Tuner, Weather Band, iPod, USB, AUX In (optional Auxiliary Input), and Bluetooth Audio.

8. Reset Button

Press the reset button:

- After initial installation of the radio; after all wiring is complete.
- If function buttons do not operate.
- If an error pops up on the display.

Use a ball point pen or similar sized object to press the reset button.

Operator's Manual

9. 6/Next Folder Button

Press the 6/Next Folder Button to go to preset 6. When navigating folders, press the 6/Next Folder Button to go to the next folder and begin playback of the first song in that folder.

10. Seek/Tune/Track Forward Button

Press the Seek/Tune/Track Forward Button to adjust menu items, seek stations (press to manually seek or press and hold to automatically seek stations in radio mode), and to go to next track in Playback Mode (press and hold to fast forward).

11. Info/Enter Button

Press the Info/Enter Button to select or enter a function and to get information.

12. Volume Down Button

Press the Volume Down Button to turn the volume down and to navigate down.

13. Seek/Tune/Track Back Button

Press the Seek/Tune/Track Back Button to adjust menu items, seek stations (press to manually seek or press and hold to automatically seek stations in radio mode), and to go to previous track in Playback Mode (press and hold to fast reverse).

14. 3/INT Button

Press the 3/INT Button to go to preset 3. When in playback mode, press the 3/INT Button to play the first ten seconds of each file on the current device. When the desired file is reached, press the 3/INT Button to end the scan and play the selected file.

15. 2/RPT Button

Press the 2/RPT Button to go to preset 2. When in playback mode, press the 2/RPT Button to repeatedly play the current file. Press the 2/RPT Button again to repeat all songs in the current folder. Press the 2/RPT Button once more to resume normal playback.

16. Band/Search Button

Press the Band/Search Button to navigate between the three FM bands and the two AM (MV) bands. In playback mode, press the Band/Search Button to enter search mode.

17. Audio/Menu Button

Press the audio menu button to access the system menu. Continue to press the system menu button to navigate through the system menu. When the proper menu is displayed, press the volume buttons within 5 seconds to adjust that option.

Bass

Adjusts from “-6” to “+6”.

Treble

Adjusts from “-6” to “+6”.

Balance

Adjusts from “L12” (Full Left) to “R12” (Full Right).

Fade

Adjusts from “R12” (Full Rear) to “F12” (Full Front).

18. Mute Button

Press this button to mute audio output. Press again to enable audio output.

19. Power Button

Press the power button to turn the system ON; press it again to turn the system OFF.

20. 1/>II Button

Press the 1/>II Button to go to preset 1. When in playback mode, press the 1/>II Button to pause playback. Press the 1/>II Button once more to resume playback.

21. Volume Up Button

Press the Volume Up Button to turn the volume up and to navigate up.

Operator's Manual

System Menu

1. Press and hold the Audio/Menu Button for more than 2 seconds to enter the system menu.
2. Press the Volume Up Button repeatedly to navigate the system menu and select the desired item.
3. Press the Info/Enter Button or Seek/Tune/Track Forward Button to adjust the selected menu item.
4. Press the Automatically Store/Preset Scan/Quick Exit Hot Key Button to go back to the previous operation.

The following items can be adjusted within the System Menu:

- Key Beep (ON/OFF): Turn the audible beep ON/OFF (heard when functions/buttons are selected).

Note: Beep tone OFF will not affect Battery Alarm audible tone.

- LCD Backlight (1/10–10/10): Adjust LCD brightness.
- LCD Contrast (1/10–10/10): Set LCD contrast.
- Tuning Region (USA/Europe): Set frequency spacing for various regions.
- Weather Alert Configure: Press the Info/Enter Button to see weather alert options:
 - Weather Alert (ON/OFF): Determines if the weather band alert feature is activated.
 - Alert Volume (1/40–40/40): Set default volume for weather alert broadcasts.
- Battery Alarm (ON/OFF): Monitor voltage on ACC line and send alert when voltage is low.
- Battery Auto–OFF (ON/OFF): Automatically turn OFF power to system when battery voltage is low.

Note: Bluetooth Device and Bluetooth Pair menu options are only available while the Bluetooth feature is ON and the system is in Bluetooth Audio mode.

Note: A locked Bluetooth device will be overwritten from the list.

- Bluetooth Device (Lock/Unlock, Disconnect/Connect, Delete): View, lock, and delete from a list of previously paired mobile phone device models.
- Bluetooth Pair <ENTER>: Press Info/Enter Button to automatically pair a device.
- Bluetooth (ON/OFF): Choose “Bluetooth ON” or “Bluetooth OFF”.
- Volume Preset (1/40–40/40): Select an automatic turn-ON volume.
- Reset to Defaults <ENTER>: Return the EEPROM to factory default set up values. Press the Info/Enter Button to select.

Battery Alarm Operation

If Battery Alarm is set to “ON”, an alarm will sound (8 beeps every 30 sec) when the voltage drops to 10.5V (+/- 0.3V). The LCD will display the “low battery” and the current mode alternatively.

Note: “OFF” is the default setting for Battery Alarm. If the audio is muted or the volume is set to 0, the audible beep will not be heard.

Auxiliary Input

To access an auxiliary device:

1. Connect the portable audio player to the AUX IN cables routed from the rear of the system.
2. Press the Mode Button to select Aux In mode.
3. Press the Mode Button again to cancel Aux In mode and switch to the next mode.

Preset Stations

Six numbered preset buttons store and recall stations for each band.

To store a station:

Select a band (if needed), then select a station. Press and hold a preset button for two seconds. The preset number will appear in the display.

To recall a station:

Select a band (if needed). Press a preset button to select the corresponding stored station.

Operator's Manual

Weather Band Operation

Note: If the system is programmed for European operation, the Weather Band function will be disabled.

Press the Mode Button to access weather band mode.

What is the NOAA Weather Radio?

NOAA is a nationwide system that broadcasts local weather emergency information 24 hours a day. The U.S. network has more than 530 stations covering the 50 states, as well as the adjacent coastal waters, Puerto Rico, the U.S. Virgin Islands and the U.S. Pacific Territories. Each local area has its own transmitting station and there are a total of seven broadcasting frequencies used: 162.400MHz (CH2), 162.425MHz (CH4), 162.450MHz (CH5), 162.475Mhz (CH3), 162.500MHz (CH6), 162.525MHz (CH7) and 162.550MHz (CH1).

How many stations can I expect to receive?

Since the broadcasts pertain to local weather and information, the transmission power is usually very low (much less than AM or FM stations) which means you will usually receive only one station unless you are on the edge of two or more broadcast signals. The most you will receive is two or three.

Is it possible I won't receive any stations?

Depending on location, it's possible to receive a very weak signal or none at all. Also, similar to AM and FM signals, weather band signals are subject to surrounding conditions, weather, obstructions of the signal by hills or mountains, etc. If no NOAA signals are found/received, the tuner will scan all seven NOAA frequencies every 30 seconds.

How will I know I am tuned to the weather band?

When you select the weather band, the "WB" icon will appear on the LCD, along with the current channel indication. Press the Seek/Tune/Track Forward or Back Buttons to tune to each of the seven channels until you find the weather band station broadcasting in your area.

NOAA Weather Alert

The Weather Alert function adds an additional level of user safety by automatically switching from the current function mode to weather band mode for a minimum of 120 seconds if a NOAA warning tone (1050 Hz) is received/detected. If no additional warning tone is received for 60 seconds, the system will switch back to the last known function mode.

The Weather Alert function can be turned ON or OFF by the Audio/Menu Button. When ON, the weather tuner remains active, even when the system is turned OFF (as long as the power is still applied to the system). If a weather alert is issued, the system will turn ON and play the announcement for 60 seconds, then turn back OFF and revert to weather alert monitor mode.

The system will not respond to any weather alerts when it is OFF and will not automatically switch to the weather band if an alert is issued.

Operator's Manual

MP3/WMA Operation

MP3/WMA File Requirements:

This system can play MP3 (MPEG1, 2, 2.5 Audio Layer 2/3) and WMA (version 7/8/9).

Media Requirements

The following formats are available for the media used in this system. The maximum number of characters used for file name, including the delimiter (“.”) and three-character extension, are indicated in parentheses:

- ISO 9660 Level 1 (11 characters)
- ISO 9660 Level 2 (31 characters)
- Joliet (31 characters)
- Romeo (31 characters)

The media reproducible on this system has the following limitations:

- Maximum number of nested folders: 8
- Maximum number of files per device: 999
- Maximum number of folders per device: 99

Use the following settings when compressing audio data in MP3 data with the MP3 encoder:

- Transfer bit rate: 32 – 320 kbps
- Sampling frequency
 - MPEG1: 32/44.1/48 KHz
 - MPEG2: 16/22.05/24 KHz
 - MPEG2.5: 8/11.025/12KHz
 - WMA: 22/32/44/48KHz
- Maximum file/directory name: 64 bytes

ID3 Support

This system supports ID3 tag versions 1.0, 1.1, 2.0, and 2.3 (Max 32 bytes).

Installing a USB Device

Insert your USB thumb drive into the USB connector routed from the rear of the radio. The system will automatically search for MP3 and WMA files on the device and begin playback. You can access USB mode from any other mode by pressing the Mode Button.

Note: Do not remove the device when USB PLAY mode is active. Press the Mode Button to change to another mode before removing the device.

MP3/WMA Directory Search

1. Press the Band/Search Button to enter directory search mode.
2. The LCD will display the folder list for the current directory. Press the Band/Search Button to view the folder directory list.
3. Navigate the folder list by pressing the Volume Up and Down Buttons.
4. Press the Info/Enter Button to select a folder. The LCD will display the list of files within that folder.
5. Navigate the file list by pressing the Volume Up and Down Buttons.
6. Press the Info/Enter Button to select a file.
7. Use the Automatically Store/Preset Scan/Quick Exit Hot Key Button to reverse navigate the list.

iPod Operation

This system is equipped with an iPod ready function that will allow the Operator to control their iPod (if compatible) using the control panel buttons. The following iPod versions are supported:

- iPod Nano 5G, iPod Nano 6G
- iPod 5G
- iPod Classic
- iPhone 4, iPhone 4S
- iPod Touch 3G, iPod Touch 4G

Note: Earlier model iPods may not be supported because they do not implement the USB control protocol. Also, the iPod Shuffle is not supported because it does not utilize the 30-pin Apple iPod Connector. These unsupported iPod models may be connected to the radio using one of the Auxiliary Inputs.

Accessing iPod Mode

Connect a supported iPod or iPhone to the USB connector. The iPod icon illuminates in the bottom left corner of the LCD whenever an iPod or iPhone is attached to the USB connector. Music playback begins automatically.

To enter iPod mode from any other source, press the Mode Button until “LOADING” appears on the display. If the user connects an iPod containing no songs, the radio will display a message stating “Device No File” when it enters iPod mode.

Operator's Manual

Turning The iPod ON/OFF

The iPod power turns on automatically when an iPod is connected to the USB connector, as long as the crane ignition is turned ON. You can turn the iPod OFF by disconnecting it or by turning the ignition OFF. When the ignition is turned OFF, the iPod will pause and then enter sleep mode after 2 minutes. While the iPod is connected, the power cannot be turned ON or OFF from the iPod itself.

Note: The iPod will continuously recharge while in iPod playback mode.

iPod Search Mode

1. Press the Band/Search Button to enter iPod search mode and choose from the following search criteria: Playlist, Artist, Album, Song, Genre, Composer, Audiobooks, and Podcasts (consecutively).
2. When search mode is selected, press the Info/Enter Button to confirm selection.
3. Use the Volume Up and Down Buttons to navigate through various list selections.
4. Press Info/Enter Button to make your final selection.
5. Use the Automatically Store/Preset Scan/Quick Exit Hot Key Button to reverse navigate the list.

Bluetooth® Operation

This system includes built-in Bluetooth technology that allows you to connect this system to Bluetooth devices for streaming audio playback.

Bluetooth is a short-range wireless radio connectivity technology developed as a cable replacement for various electronic devices. Bluetooth operates in 2.4 GHz frequency range and transmits voice and data at speeds up to 1 megabit per second. Bluetooth was launched by a special interest group (SIG) comprised of Ericsson Inc., Intel Corp., Nokia Corp., Toshiba and IBM in 1998, and it is currently developed by nearly 2,000 companies worldwide. The Bluetooth word mark and logos are owned by the Bluetooth SIG, Inc. and any use of such marks is under license. Other trademarks and trade names are those of their respective owners.

Note: Some Bluetooth menu options are only available while the system is in Bluetooth Audio mode.

Bluetooth Menu Options

Press and hold the Audio/Menu Button to enter menu adjustment mode. Repeatedly press the Volume Up and Down Buttons to access the "Bluetooth ON/OFF" menu function. Press the Info/Enter Button to turn the Bluetooth function ON or OFF. The following menu options are available when the system is in Bluetooth mode:

- **Bluetooth Pair <ENTER>**: Press the Info/Enter Button to begin pairing with a Bluetooth enabled device in pairing mode.
- **Bluetooth Device**: Press the Info/Enter Button to view a list of previously paired mobile phone device models. Press the Seek/Tune/Track Forward and Press the Seek/Tune/Track Back Buttons to view devices from the list. A device that is actively connected cannot be deleted. Press the Info/Enter Button to select the device. Press the Seek/Tune/Track Forward and Press the Seek/Tune/Track Back Buttons to choose Lock/Unlock, Disconnect, or Delete for this device.
- **Lock/Unlock**: The system can store up to 5 devices for Bluetooth connection. The devices are stored in FIFO (First In First Out) order. To prevent a device from being bumped from the list when more than 5 devices are used, the device must be locked. To Lock/Unlock a device, press the Info/Enter Button to display/change the Locked or Unlocked icon.
- **Disconnect**: To disconnect a paired device, press the Info/Enter Button to temporarily remove the Bluetooth link. The link can be re-established through the phone menu by selecting the system for connection.
- **Delete**: To delete a device from the list, press the Info/Enter Button.

Operator's Manual

Pairing A Bluetooth Device

Before you begin, consult the owner's manual for the Bluetooth device you want to pair with this system.

1. Ensure the device is on and ready to receive a signal from the system. With the system in Bluetooth Audio mode, choose BT PAIR from the system menu and press the Info/Enter Button to select ON. The system is waiting to connect to a mobile phone device. With the Bluetooth function of the mobile phone device turned ON, search for a Bluetooth device.
2. When the Bluetooth device has completed its search, the mobile phone will display the Bluetooth device name (JHD40BT).
3. Select JHD40BT. The Bluetooth Audio icon (🎵) will now be displayed on the LCD.
4. Enter the pairing password (0000), if requested.

After connecting successfully, the Operator can listen to music stored on their Bluetooth enabled device through the system.

Answering A Call

When answering a call using the connected phone, Bluetooth Audio will pause. After hanging up from the call, Bluetooth Audio will continue on some phones. It may be necessary to press the play button to resume Bluetooth Audio.

BT Audio (A2DP)

The A2DP music is available for Bluetooth enabled phones when the phone is connected. To access Bluetooth mode and play songs stored on your phone.

1. Press the Mode Button.
2. While in Bluetooth mode, the Bluetooth Audio icon (🎵) illuminates on the LCD.
3. If the system is changed to another mode, the mobile phone audio will pause. Press the Mode Button to return to Bluetooth mode and resume mobile phone audio playback.

Note: If a Bluetooth device is disconnected due to the power being turned OFF or if the device is disconnected inadvertently, the system will automatically search for the matching Bluetooth mobile phone when the power is restored.

Operator's Manual

Care And Maintenance

- Keep the system dry. If it does get wet, wipe it dry immediately. Liquids might contain minerals that can corrode the electronic circuits.
- Keep the product away from dust and dirt, which can cause premature wear of parts.
- Handle the system gently and carefully. Dropping it can damage circuit boards and cases, and can cause the system to work improperly.
- Wipe the system with a dampened cloth occasionally to keep it looking new. Do not use harsh chemicals, cleaning solvents, or strong detergents to clean the system.
- Use and store the system only in normal temperature environments. High temperature can shorten the life of electronic devices, damage batteries, and distort or melt plastic parts.

Ignition

- The most common source of noise in reception is the ignition system. This is a result of the radio being placed close to the ignition system (engine). This type of noise can be easily detected because it will vary in intensity of pitch with the speed of the engine.
- Usually, the ignition noise can be suppressed considerably by using a radio suppression type high voltage ignition wire and suppressor resistor in the ignition system. Another method of suppression is the use of additional noise suppressors.

Interference

- Radio reception in a moving environment is very different from reception in a stationary environment (home). It is very important to understand the difference.
- AM reception will deteriorate when passing under a bridge or when passing under high voltage lines. Although AM is subject to environmental noise, it has the ability to be received at great distance. This is because broadcasting signals follow the curvature of the earth and are reflected back by the upper atmosphere.

Operator's Manual

| Radio Troubleshooting | | |
|---|---|---|
| Symptom | Cause | Solution |
| No power | The accessory switch is not ON | If the power supply is properly connected to the cranes accessory terminal, switch the ignition key to "ACC". |
| | Fuse is blown | Replace the fuse. |
| No sound | Volume is too low | Adjust volume to audible level. |
| | Wiring is not properly connected | Check wiring connections. |
| The operation keys do not work | Built-in microcomputer is not operating properly due to noise | Press the Reset Button. |
| Cannot tune to radio station, auto-seek does not work | Antenna cable is not connected | Insert the antenna cable firmly. |
| | Signals are too weak | Select a station manually. |

Operator's Manual

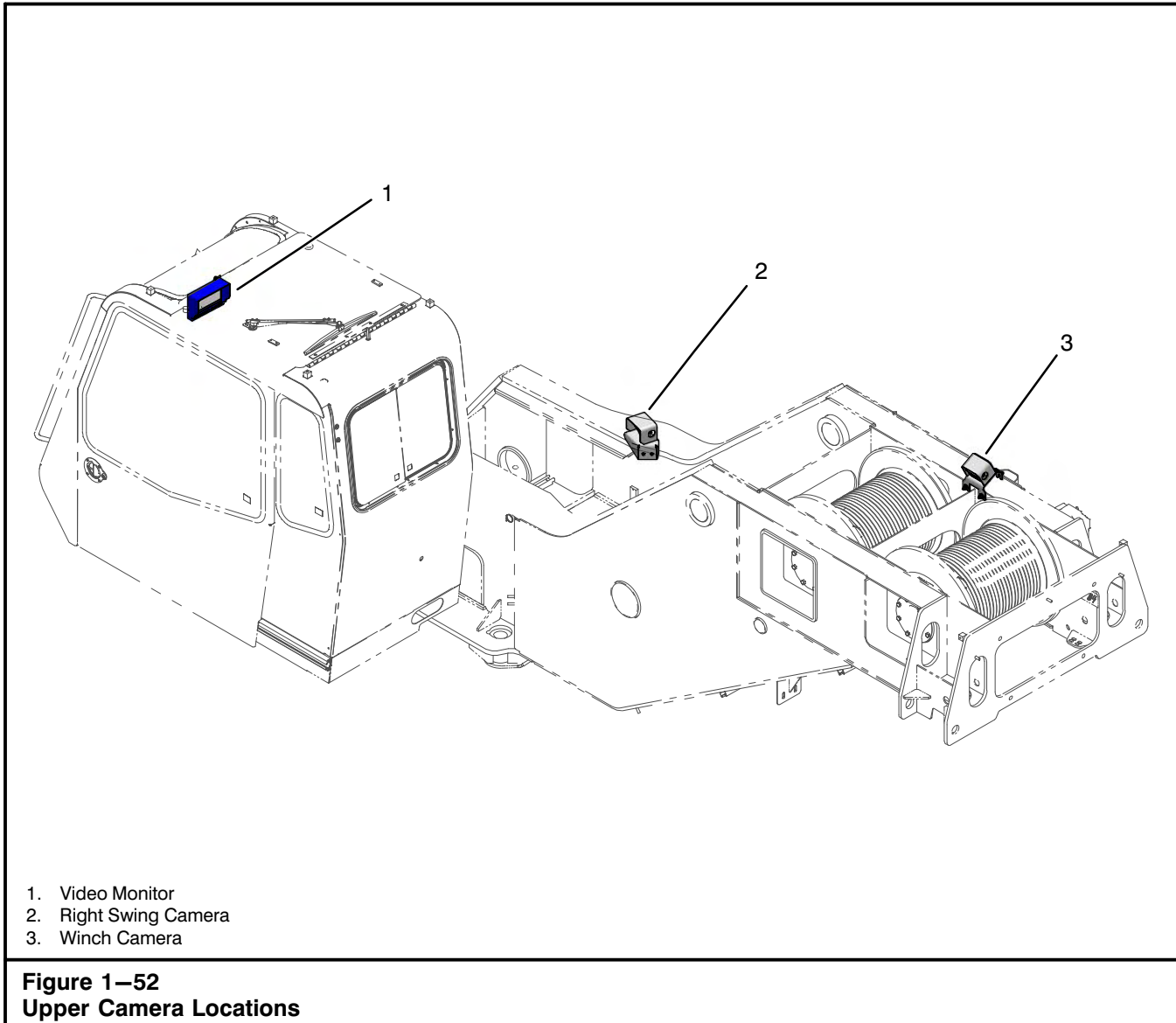

Winch And Right Swing View Cameras

The upper is equipped with two cameras. One camera gives the operator a view of the winches to monitor wire rope spooling on the winch drum(s). The other camera gives a view of the area to the right side the crane to be used before swinging the upper to the right.

During initial crane start up and inspection each day, verify the proper operation of all cameras. If the cameras are found to be damaged or missing, order replacement parts as required to repair or replace the damaged or missing component. Continue operation with caution as you should normally do with all crane operations.



WARNING

Cameras are being supplied as an operator's aid. They do not relieve the crane operator of any responsibilities during crane operation. Always look directly in the direction of crane travel or at the load during crane lifting operations. Do not rely solely on the camera to determine if an obstruction is present.

When the swing brake is released the monitor will automatically display the right swing view.

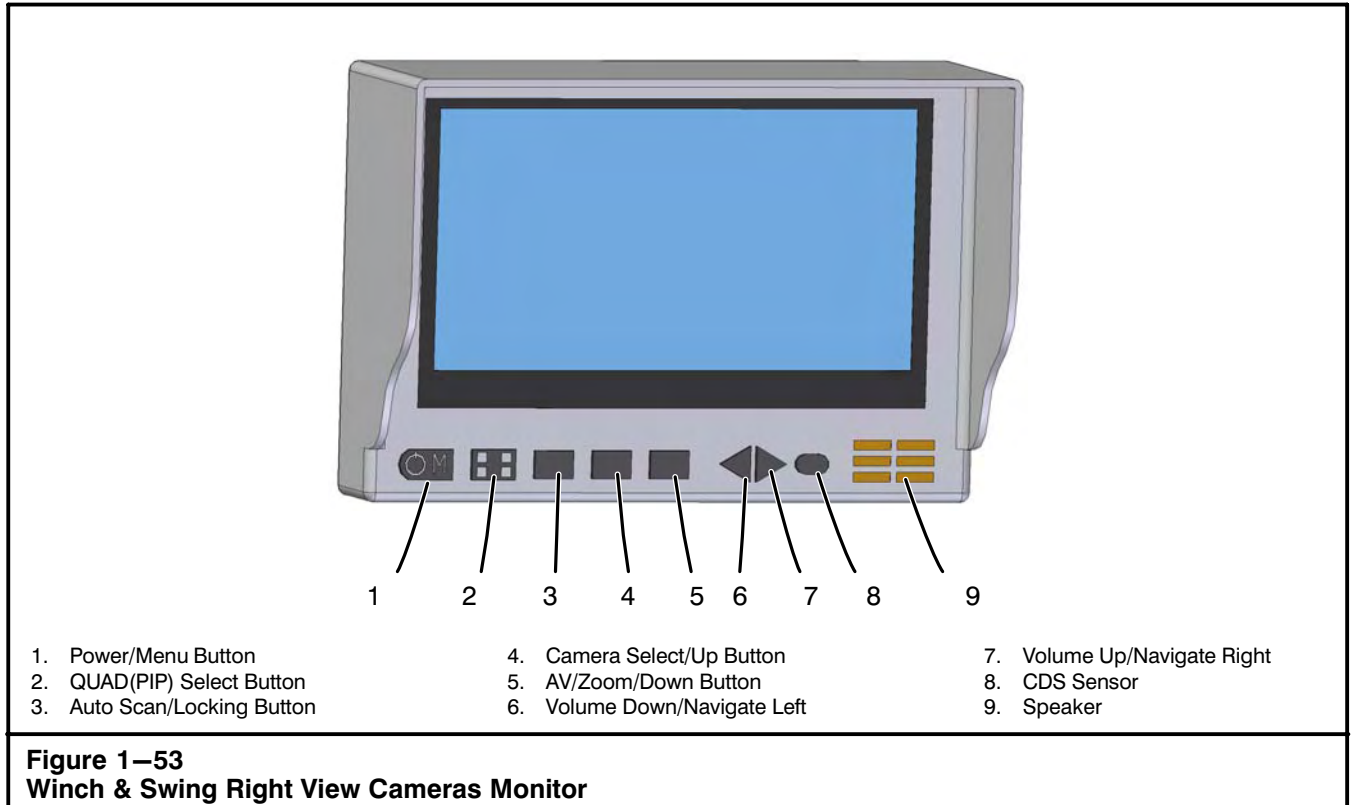

Camera Monitor

A video monitor in the Operator's Cab is supplied to help the Operator see areas that can be obstructed from their view. This monitor can distract the Operator from their normal duties if not used properly. Use these monitors as an Operator's aid and not as the sole method of seeing where the crane is going. Primary attention is to be on where the crane is going or the lifted load, not the monitor.

Cameras do not eliminate the requirement for a signal person during crane travel. Do not attempt to move the crane without a signal person. A trained signal person working in conjunction with a trained Operator is required to move the crane.

WARNING

Do not rely solely on the cameras and monitors.

- **The field of vision of the camera may be limited.**
- **Just because the monitor looks clear does not mean that an obstruction does not exist.**
- **Images in the monitor may be farther than they appear.**
- **Images in the monitor may be distorted.**
- **Weather conditions (ice, snow, rain, etc) may distort or block the camera lens and inhibit visibility.**
- **Do not operate the crane using the camera's alone.**
- **Always look before moving the crane.**
- **Always employ a signal person to move the crane.**

Operator's Manual

1. Power/Menu Button

Power

Press the top left corner of the Power/Menu Button to turn the monitor ON.

Press and hold the top left corner of the Power/Menu Button to turn the monitor OFF.

Menu (While Monitor Is Powered ON)

Press the bottom right corner of the Power/Menu Button to enter MENU MODE.

Press the AV/Zoom/Down Button or Camera Select/Up Button to scroll through the MENUS.

2. QUAD(PIP) Select Button

The QUAD(PIP) Select Button allows the Operator to change the monitor to a split screen display. Refer to "Split Screen Displays" in this section of the Operator's Manual for additional information.

3. Auto Scan/Locking Button

Auto Scan

Press the Auto Scan/Locking button one time to initiate auto scan mode. Auto scan mode will scroll through the camera views for a set period of time as follows: CA1->CA2->CA3->CA4. After the last camera (CA4) is shown in scan mode the screen will automatically go back to the first camera (CA1). Refer to "SCAN Function" in this section of the Operator's Manual for additional information.

Button Lock

Hold the Auto Scan/Locking Button for 3 seconds to lock all of the buttons. At this time all functions of the buttons are disabled. While the buttons are locked, press and hold the Auto Scan/Locking Button for 3 more seconds to unlock the buttons.

4. Camera Select/Up Button

Press the Camera Select/Up Button to scroll through the camera views one by one and to get out of a split screen view. Press the Camera Select/Up Button while in MENU MODE to scroll UP.

5. AV/Zoom/Down Button

Press the AV/Zoom/Down Button to zoom in on a specific camera view. Press the AV/Zoom/Down Button while in MENU MODE to scroll DOWN.

6. Left Arrow Button

The left arrow button turns the volume down and changes functions within the MENUS.

7. Right Arrow Button

The right arrow button turns the volume up and changes functions within the MENUS.

8. CDS Sensor

The CDS Sensor has an auto dimming feature making the monitor available for night viewing.

9. Speaker

The speakers allows the Operator to hear sounds within the camera view.

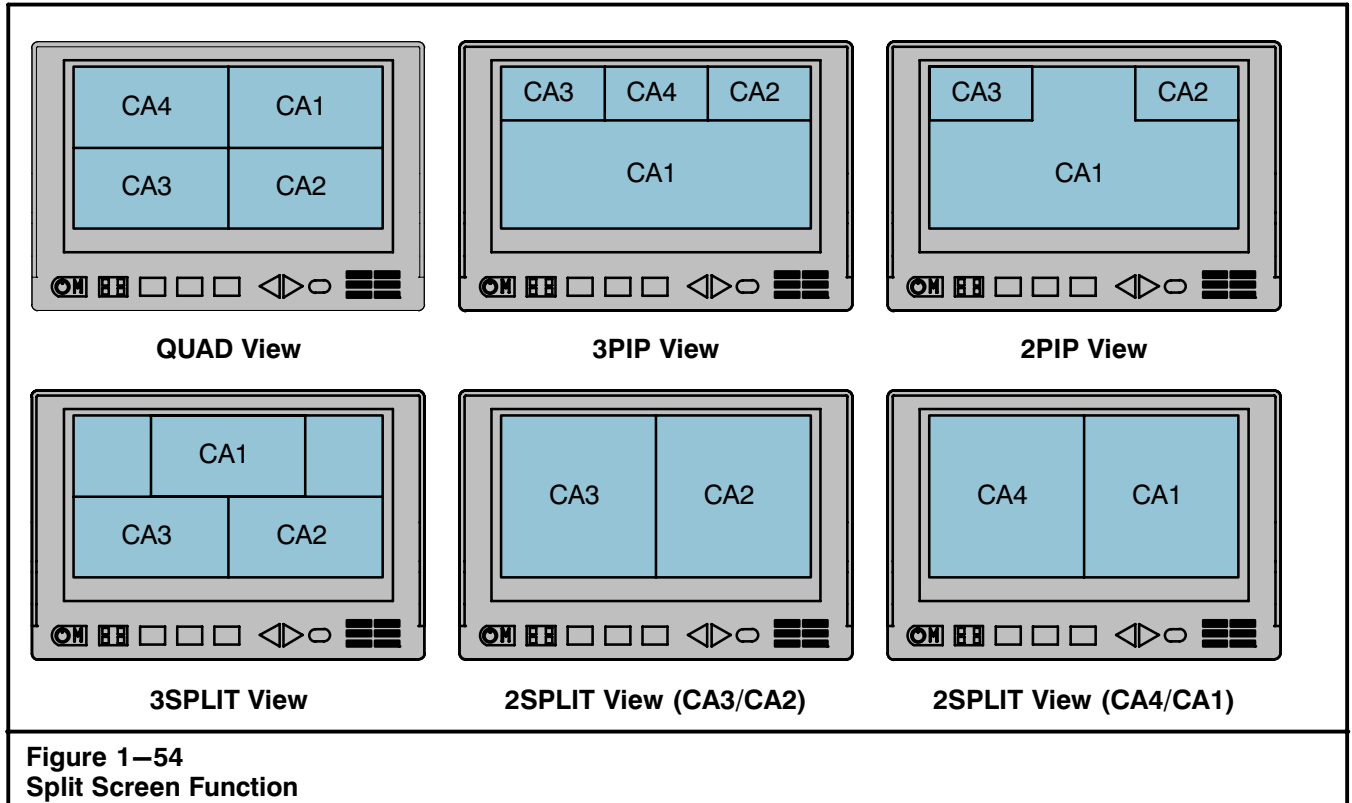

Split Screen Function

The upper camera has split screen capabilities allowing the Operator to view up to four cameras on one screen. Refer to Figure 1–54. Depending upon which split screen views are turned on, press the QUAD(PIP) Select Button to scroll through the different split screen views. To turn ON/OFF a split screen view:

Refer to Figure 1–53.

1. Press the Power/Menu Button to enter MENU MODE.

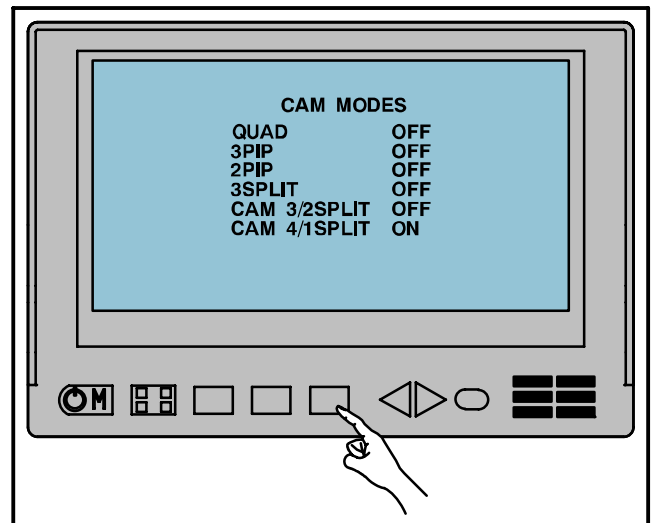

2. Press the AV/Zoom/Down Button until CAM MODES is displayed on the screen.

Operator's Manual

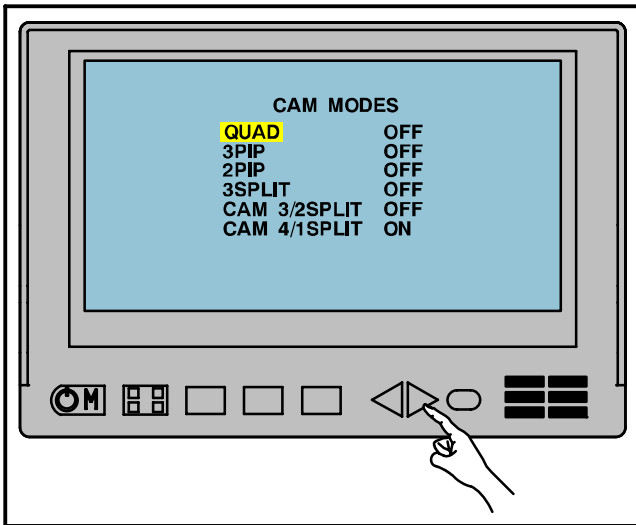

3. Press the Right Arrow Button to enter into CAM MODES.

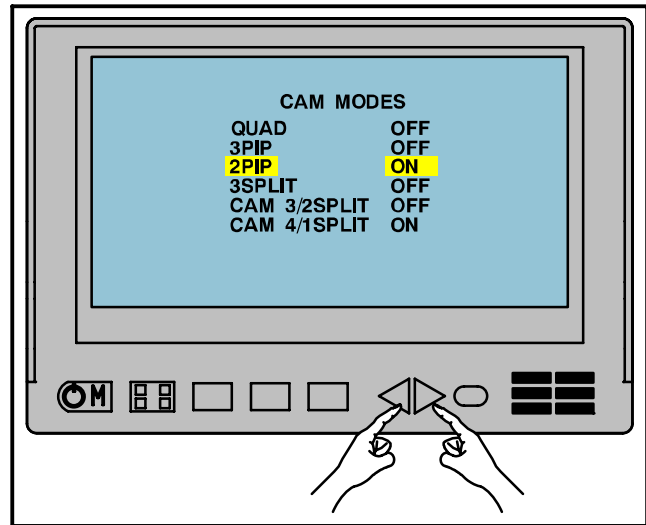

5. When the proper split screen mode is selected press the Left Arrow or Right Arrow Button to turn it ON or OFF.

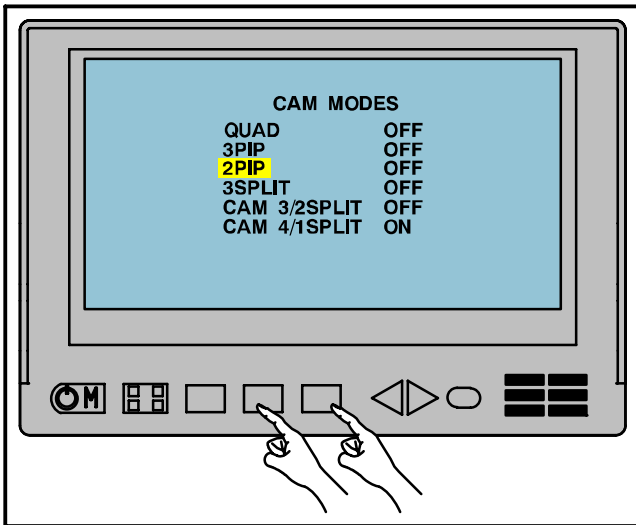

4. Press the Camera Select/Up or AV/Zoom/Down Button to scroll UP and DOWN within CAM MODES.

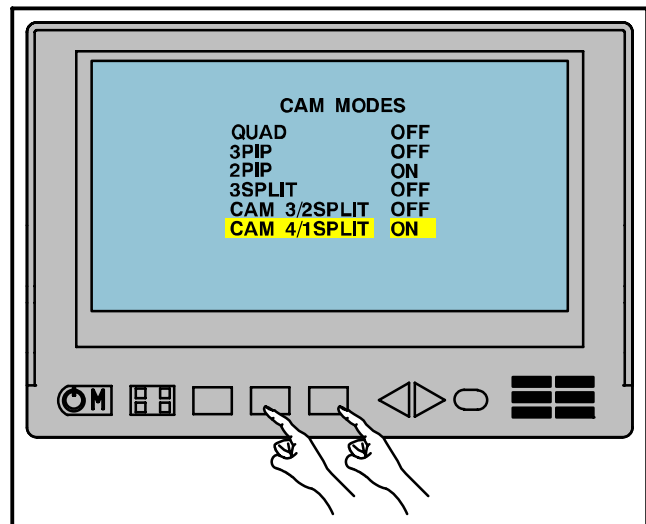

6. To turn ON or OFF another split screen mode press the Camera Select/Up or AV/Zoom/Down Button to scroll UP and DOWN.

Operator's Manual

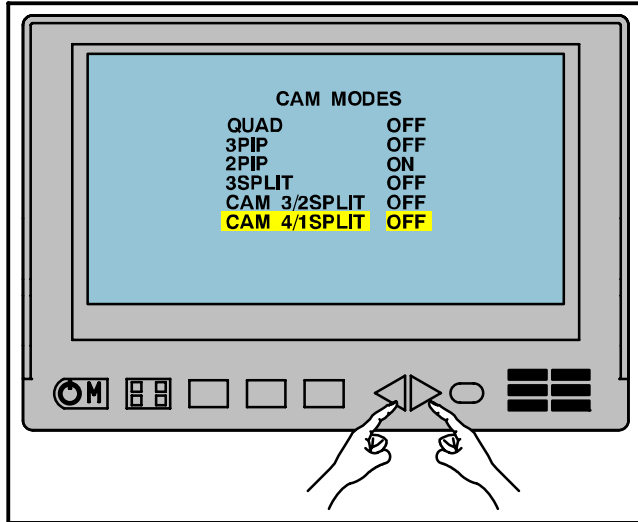

7. Then press the Left Arrow or Right Arrow Button to turn it ON or OFF.
8. To go back to MENU MODE press the Power/Menu Button.

Note: If the crane is equipped with two cameras, only CAM4/1SPLIT MODE needs to be on.

Operator's Manual

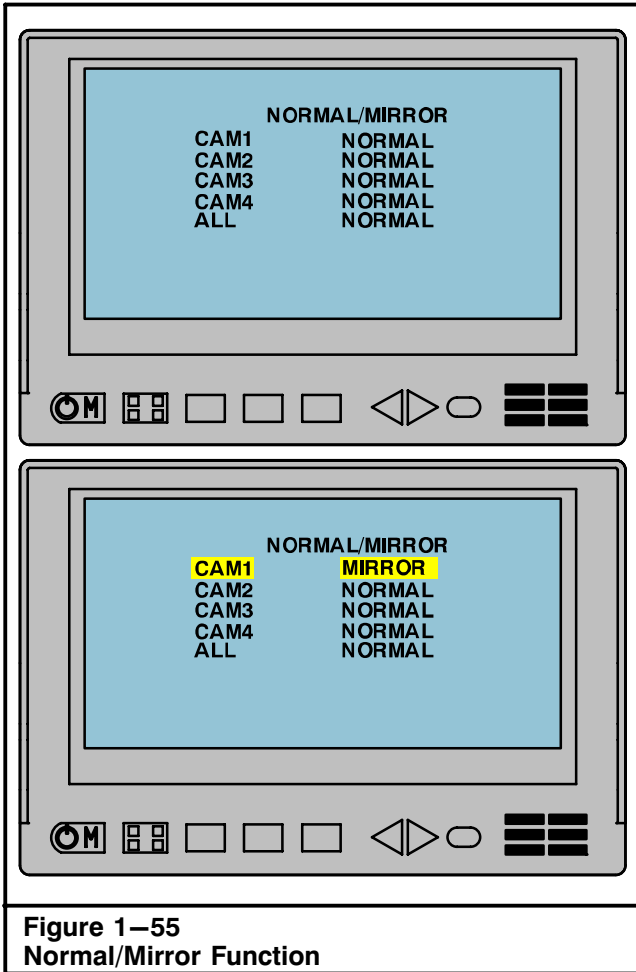

Figure 1-55
Normal/Mirror Function

NORMAL/MIRROR Function

The upper monitor has a NORMAL/MIRROR Function that allows the Operator to mirror the monitor image vertically. Refer to Figure 1-55. To change the monitor image from NORMAL to MIRROR:

Refer to Figure 1-53.

1. Press the Power/Menu Button to enter MENU MODE.
2. Press the AV/Zoom/Down Button until NORMAL/MIRROR is displayed on the screen.
3. Press the Right Arrow Button to enter into NORMAL/MIRROR.
4. Press the Camera Select/Up or AV/Zoom/Down Button to scroll UP and DOWN.
5. Press the Left Arrow or Right Arrow Button to change the camera view from NORMAL to MIRROR.
6. To go back to MENU MODE press the Power/Menu Button.

UP/DOWN Function

The upper monitor has a UP/DOWN Function that allows the Operator to mirror the image horizontally. Refer to Figure 1–56. To change the monitor image from UP to DOWN:

Refer to Figure 1–53.

1. Press the Power/Menu Button to enter MENU MODE.
2. Press the AV/Zoom/Down Button until UP/DOWN is displayed on the screen.
3. Press the Right Arrow Button to enter into UP/DOWN.
4. Press the Camera Select/Up or AV/Zoom/Down Button to scroll UP and DOWN.
5. Press the Left Arrow or Right Arrow Button to change the camera view from UP to DOWN.
6. To go back to MENU MODE press the Power/Menu Button.

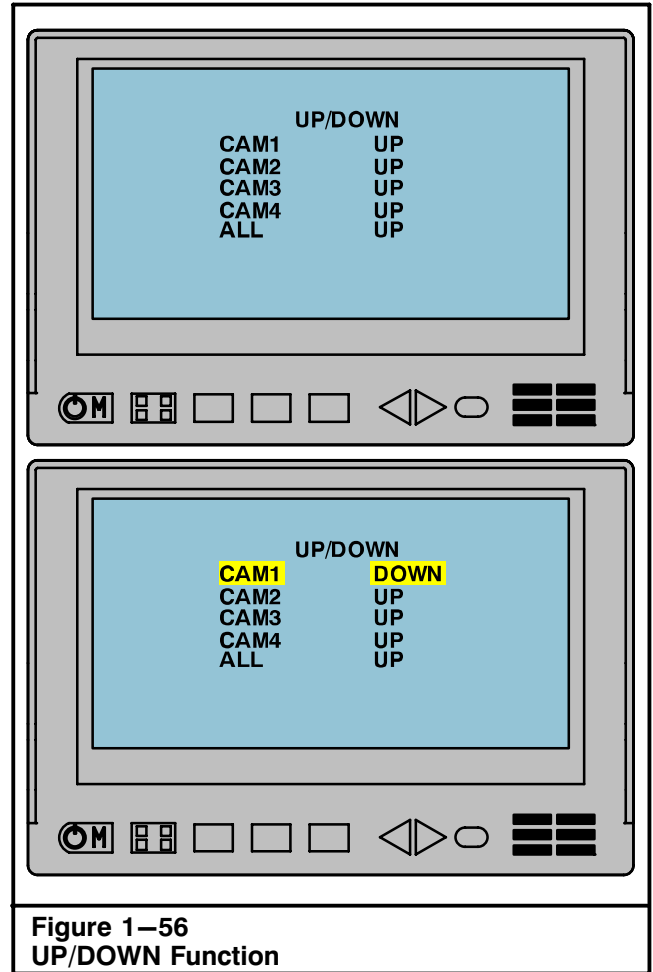

Figure 1–56
UP/DOWN Function

Operator's Manual

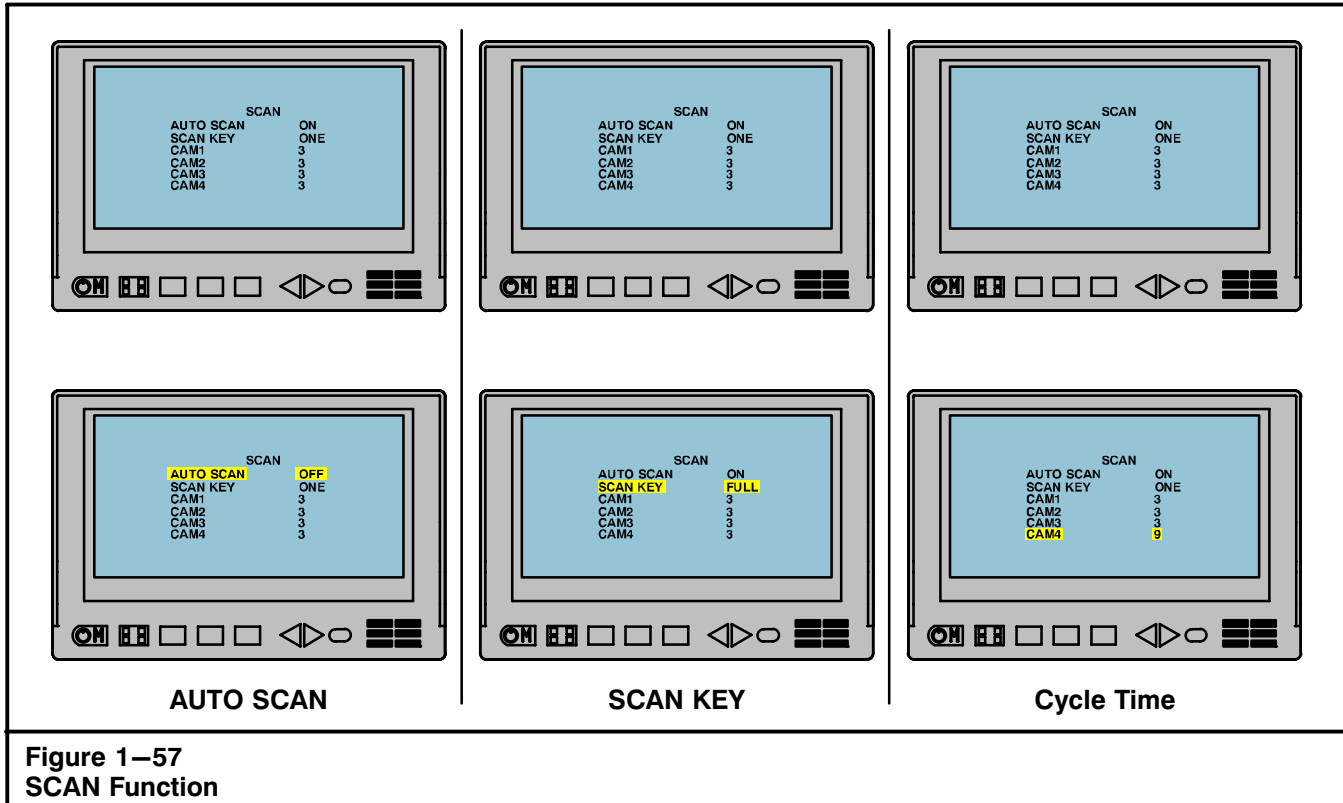

Figure 1-57
SCAN Function

SCAN Function

The upper camera has a SCAN Function that allows the monitor to automatically scan through the different camera views at the press of a button. The SCAN KEY function can be set to cycle through the camera views only one time or continuously scroll through the camera views. Refer to Figure 1-57. To start an AUTO Scan:

Refer to Figure 1-53.

1. Press the Auto Scan/Locking Button.

To turn AUTO SCAN OFF:

1. Press the Power/Menu Button to enter MENU MODE.
2. Press the AV/Zoom/Down Button until SCAN is displayed on the screen.
3. Press the Right Arrow Button to enter into SCAN.
4. Press the Camera Select/Up or AV/Zoom/Down Button to scroll UP and DOWN to AUTO SCAN.
5. Press the Left Arrow or Right Arrow Button to change AUTO SCAN from ON to OFF.
6. To go back to MENU MODE press the Power/Menu Button.

To change the SCAN KEY cycle from ONE to FULL :

1. Press the Power/Menu Button to enter MENU MODE.
2. Press the AV/Zoom/Down Button until SCAN is displayed on the screen.
3. Press the Right Arrow Button to enter into SCAN.
4. Press the Camera Select/Up or AV/Zoom/Down Button to scroll UP and DOWN to SCAN KEY.
5. Press the Left Arrow or Right Arrow Button to change SCAN KEY from ONE to FULL.
6. To go back to MENU MODE press the Power/Menu Button.

To change the SCAN cycle time:

1. Press the Power/Menu Button to enter MENU MODE.
2. Press the AV/Zoom/Down Button until SCAN is displayed on the screen.
3. Press the Right Arrow Button to enter into SCAN.
4. Press the Camera Select/Up or AV/Zoom/Down Button to scroll UP and DOWN to specific camera.
5. Press the Left Arrow or Right Arrow Button to change the time interval (1-9 seconds).
6. To go back to MENU MODE press the Power/Menu Button.

PREFERRED SETTINGS

| FUNCTION | |
|------------|----------|
| LANGUAGE | ENGLISH |
| SYSTEM | NTSC/PAL |
| DIRECTION | 0° |
| DIMMER | 1 |
| AUTO POWER | ON |
| LOGO SET | > |
| AV OUTPUT | LIVE |
| SHUTTER | ON |
| RESET | > |

| TRIGGER | |
|------------|------|
| REAR SCALE | OFF |
| BLINK MARK | OFF |
| TRIG 1 | CAM1 |
| TRIG 2 | CAM2 |
| TRIG 3 | CAM3 |
| TRIG 4 | CAM4 |
| HAZARD | QUAD |

| CAMERA NAME | |
|-------------|-----------|
| CAM1 | RIGHT |
| CAM2* | NO CAMERA |
| CAM3* | NO CAMERA |
| CAM4* | WINCH |

| CAM MODES | |
|---------------|-----|
| QUAD* | OFF |
| 3PIP* | OFF |
| 2PIP* | OFF |
| 3SPLIT* | OFF |
| CAM3/2 SPLIT* | OFF |
| CAM4/1 SPLIT | ON |

| NOR/MIR | |
|---------|--------|
| CAM1 | NORMAL |
| CAM2 | NORMAL |
| CAM3 | NORMAL |
| CAM4 | NORMAL |
| ALL | NORMAL |

| UP/DOWN | |
|---------|----|
| CAM1 | UP |
| CAM2 | UP |
| CAM3 | UP |
| CAM4 | UP |
| ALL | UP |

| SCAN | |
|-----------|-----|
| AUTO SCAN | OFF |
| SCAN KEY | ONE |
| CAM1 | 3 |
| CAM2 | 3 |
| CAM3 | 3 |
| CAM4 | 3 |

*Setting may be different if equipped with a third camera.

Figure 1–58
Monitor Preferred Settings

RESET

Note: Resetting the monitor will reset it to the monitor factory settings. The monitor will then need to be set to the Link-Belt preferred settings. Refer to Figure 1–58.

To reset the monitor settings:

1. Press the Power/Menu Button to enter MENU MODE.
2. Press the AV/Zoom/Down Button until FUNCTION is displayed on the screen.
3. Press the Right Arrow Button to enter into FUNCTION.
4. Press the Camera Select/Up or AV/Zoom/Down Button to scroll UP and DOWN to RESET.
5. Press the Left Arrow or Right Arrow Button to reset the monitor.
6. The monitor will power off during reset.

Care and Maintenance

If crane has been parked in direct sunlight, allow time for the monitor to cool down.

Clean the monitor with a slightly damp cloth. Use a mild household detergent. Do not use strong solvents such as thinner or benzene as they can damage the finish of the monitor.

Contact your Link-Belt Distributor for the proper repair procedures.

Operator's Manual

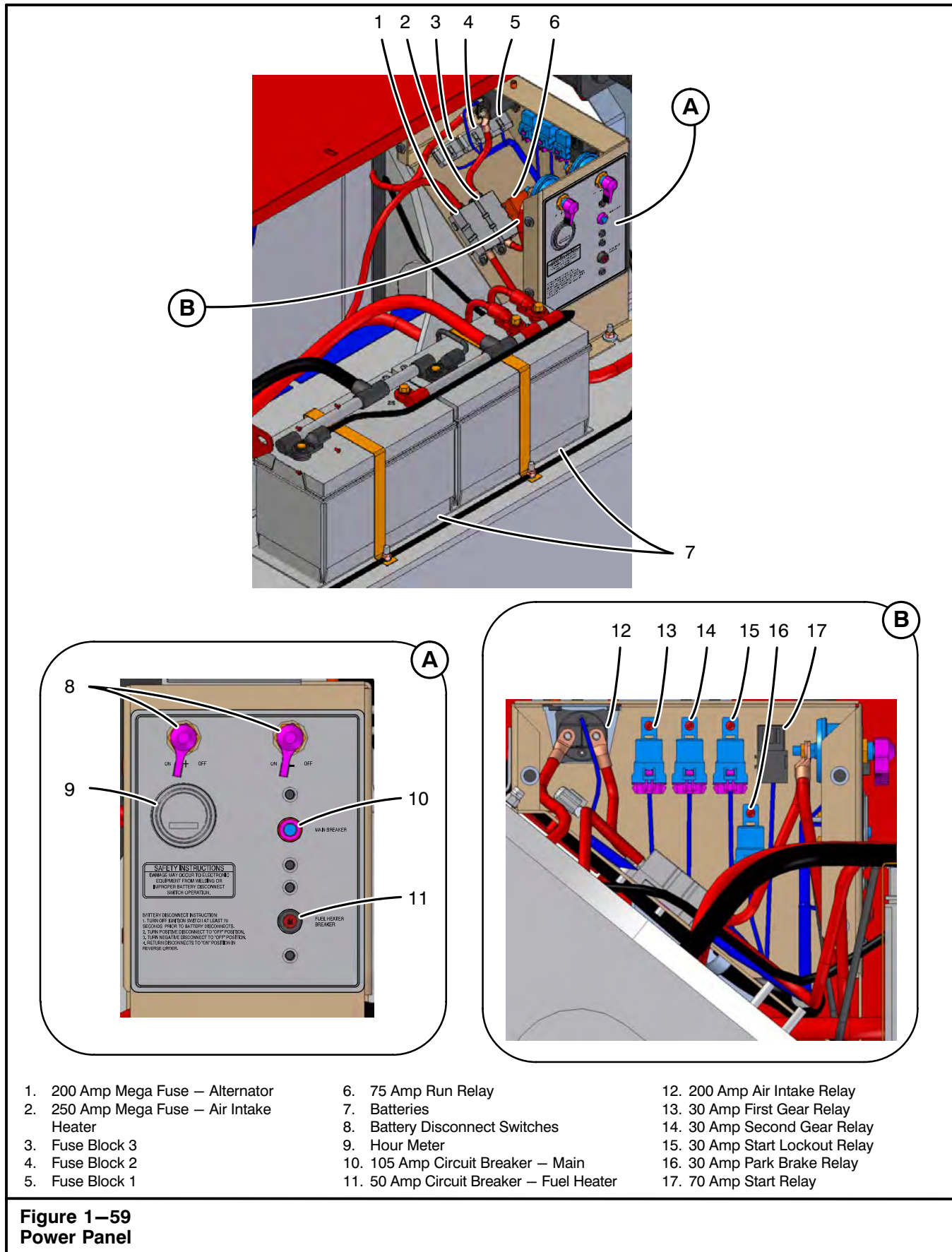

- 1. 200 Amp Mega Fuse – Alternator
- 2. 250 Amp Mega Fuse – Air Intake Heater
- 3. Fuse Block 3
- 4. Fuse Block 2
- 5. Fuse Block 1

- 6. 75 Amp Run Relay
- 7. Batteries
- 8. Battery Disconnect Switches
- 9. Hour Meter
- 10. 105 Amp Circuit Breaker – Main
- 11. 50 Amp Circuit Breaker – Fuel Heater

- 12. 200 Amp Air Intake Relay
- 13. 30 Amp First Gear Relay
- 14. 30 Amp Second Gear Relay
- 15. 30 Amp Start Lockout Relay
- 16. 30 Amp Park Brake Relay
- 17. 70 Amp Start Relay

Figure 1-59
Power Panel

Operator's Manual

Power Panel

The power panel is on the right rear of the crane behind the engine grille. Refer to Figure 1–59.

Circuit Breakers

The circuit breakers are in the power panel. Refer to Figure 1–59. There are two manual reset type circuit breakers which service the crane's electrical system. If a breaker has been tripped, push and release the breaker to reset.

Fuse Blocks

There are fuse blocks located behind the power panel. Refer to Figure 1–59. Refer to the following table to determine the type of fuses that protect the crane's electrical system.

| Fuse Block | Amp | Qty | Circuit |
|------------|-----|-----|---|
| 1 | 5 | 1 | Rear Oscillation |
| | 7.5 | 1 | Engine Jog Switch Brake, Turn, & Tail Lights Switch |
| | 5 | 1 | Hour Meter |
| 2 | 30 | 1 | Engine Control Module (ECM) |
| | 5 | 1 | |
| | 5 | 1 | Hydraulic Oil Cooler Fan |
| 3 | 10 | | 1 st & 2 nd Gear Relays |
| | 30 | 1 | Air Conditioner |

Mega Fuses

There are two mega fuses in the electrical control center. Refer to Figure 1–59. These fuses protect the alternator and engine intake air heater electrical circuits. If these system are not functioning, check and replace these fuses as required.

Hour Meter

The hour meter is on the right rear of the crane behind the engine grille. Refer to Figure 1–59. The hour meter registers engine operating hours. It is useful in determining lubrication and maintenance schedules.

Battery Disconnect Switches

The battery disconnect switches are on the right rear of the crane behind the engine grille. Refer to Figure 1–59.

CAUTION

Ignition switch should be shut off at least 70 seconds prior to turning disconnect switches to the "OFF" position.

Major damage may occur to the electronic equipment from welding on the crane prior to turning disconnect switches to the "OFF" position.

Ignition switch should be shut off at least 70 seconds prior to turning disconnect switches to the "OFF" position. Move the disconnect switches to the "Off" position before welding on the crane to protect the crane's electronic components from damage due to an electric arc type welder.

1. Shutdown the engine and wait at least 70 seconds.
2. Turn positive disconnect to the OFF position.
3. Turn negative disconnect to the OFF position.
4. Return disconnects to the ON position in reverse order.

Note: If the batteries are disconnected, the start-up time for on-board computer systems will be longer than normal.

Operator's Manual

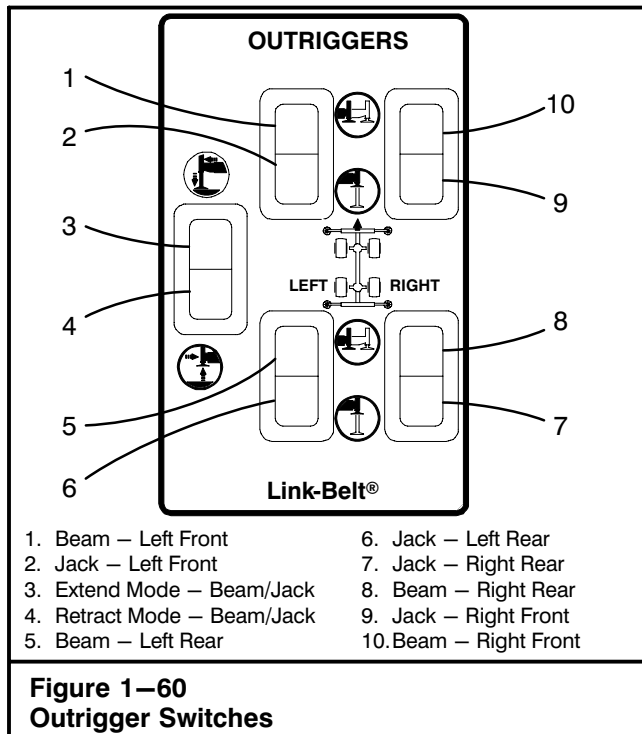

Outrigger Operation

The outriggers can be used in any one of three positions; fully retracted, intermediate extended, or fully extended. The outriggers are controlled by switches on a hand held control box connected by a cable (Refer to Figure 1–60) and the extend position levers on the outrigger boxes (Refer to Figure 1–61). Each outrigger switch (Left Front, Left Rear, Right Front, Right Rear) controls all functions of that outrigger beam and jack cylinder. The mode switch controls outrigger cylinder direction, extend/retract. The extend position levers control the extend length of the beams. They allow for beams to be fully extended, or limits them to intermediate extended lengths based on the selected position of the extend position levers.

The outrigger pontoons must set on a smooth, solid surface flush with ground with no hills or valleys under them or they may be damaged or destroyed. If there is any doubt as to the ground conditions, use mats under the pontoons. Check pontoons before and during operations. If they are allowed to settle, they may lose their effectiveness, and make continued operations unsafe.

A bubble level is mounted in operator's cab, to assist in determining when crane is level. Refer to Figure 1–64. The hand held, tethered control box stores on the right side wall of the cab near the operator's seat. The control box allows the operator to remotely control all outrigger functions.



WARNING

Do not extend or retract an outrigger beam or jack unless it is in full view of the operator or signal person. Ensure all personnel and obstructions are clear from the path of the machinery.

To Extend Outrigger Beams

1. Park crane in the desired location. Engage the park brake, shift the transmission to neutral, and shutdown engine. Engage main hydraulic pump.
2. Remove the pontoons from storage, and attach one to each outrigger jack.



WARNING



Pontoons must be attached to outrigger jacks before crane is set on outriggers. If pontoons should settle, the jacks could disengage from the pontoons, causing a loss of stability.

3. Determine the outrigger position desired. Set the extended position levers as required. (Refer to Figure 1–61.)



WARNING

When making lifts on outriggers, all outrigger beams must be equally extended; all fully retracted, all intermediate extended, or all fully extended. Failure to do so will cause a loss of stability and possible crane damage and/or personal injury.

4. Start the engine.
5. Push an outrigger switch to the beam position  and hold.
6. Push the mode switch to extend mode on position  and hold until the beam reaches the selected position; intermediate extended or fully extended.
7. When beam reaches selected position, release both switches.
8. Repeat Steps 5–7, for each outrigger beam, until all the beams are set to the selected position.

Note: As conditions warrant, a proficient crane operator may operate multiple beams such as one end or side at the same time.

9. If the intermediate extended beam position is to be used, visually check that all beams are properly positioned in the intermediate extended position. All beams must be extended until the stop plate contacts the extend position lever and the arrow is aligned with the outrigger box collar. Refer to Figure 1–61.

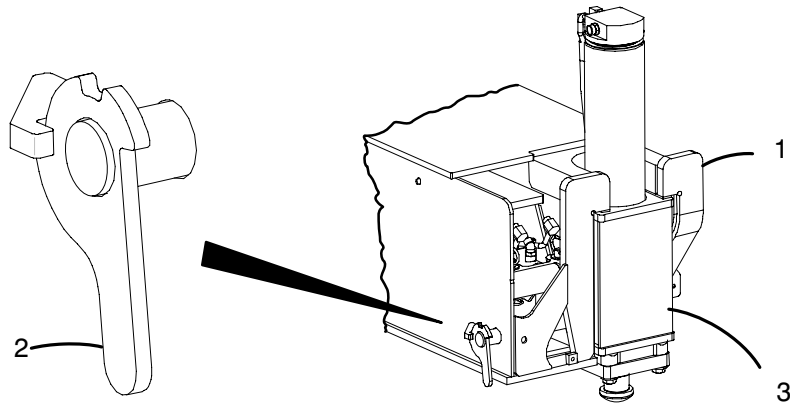

Fully Retracted

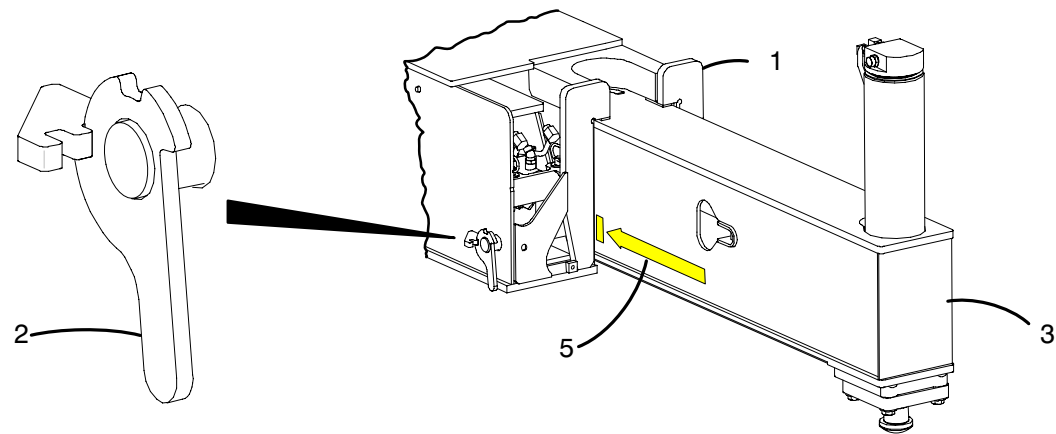

Intermediate Extended

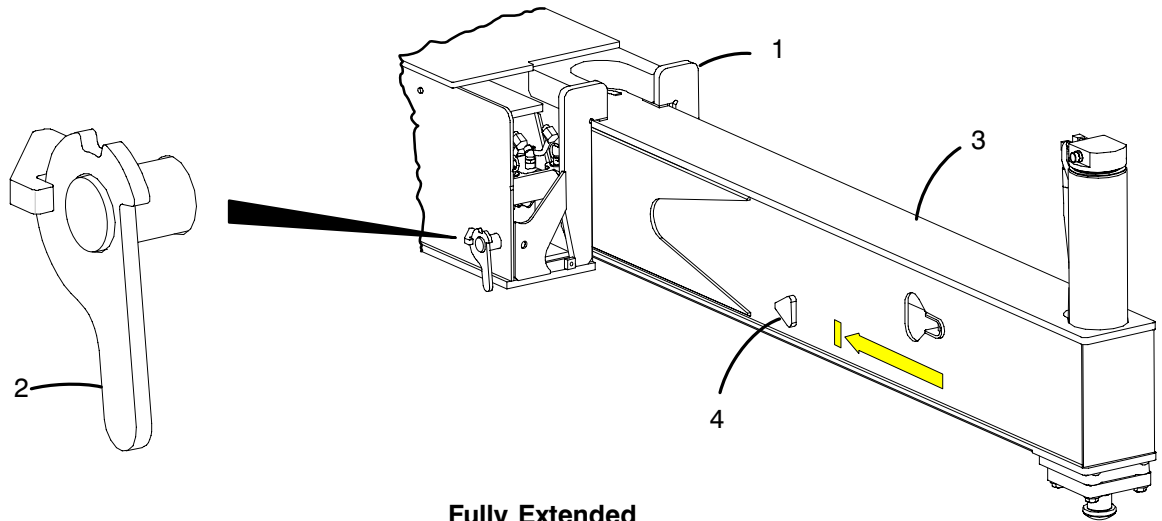

Fully Extended

- 1. Outrigger Box Collar
- 2. Extend Position Lever
- 3. Outrigger Beam

- 4. Stop Plate (For Intermediate Position)
- 5. Alignment Arrow (For Intermediate Position)

Figure 1-61
Outrigger Extend Position Lever

Operator's Manual

10. Set the Rated Capacity Limiter to the proper setting to match the position of the outrigger beams.

Note: If an “Outrigger Position Mismatch” warning appears on the display, ensure the outriggers are in the correct position and select the configuration on the display to match the current outrigger position.



WARNING

When making lifts with the crane on outriggers, all outrigger beams must be equally extended; fully retracted, intermediate extended, or fully extended.

When making lifts with the outrigger beams in the intermediate extended position, the extend position lever must be in the intermediate extended position. Visually check that all outrigger beams are extended until the stop plate contacts the extend position lever and the arrow is aligned with the outrigger box collar before beginning operations.

Check that the Rated Capacity Limiter is set to the correct outrigger position before beginning operation.

Failure to perform any of the above may cause crane damage and/or serious personal injury.

To Extend Outrigger Jacks – Raise The Crane

1. With the beams extended to the selected position (fully retracted, intermediate extended, or fully extended), push an outrigger switch to the jack position  and hold.

CAUTION

When the hoist line is tied off to the crane or any solid object, the winch system can be overloaded causing major winch, wire rope, or crane damage. Do not extend boom, raise or lower the boom, or raise the crane on outriggers unless wire rope is spooled off the drum to prevent tension on the wire rope.

2. Push the mode switch to extend mode on  and hold until the jack cylinder is fully extended.
3. Release both switches.
4. Repeat Steps 1–3 for each outrigger jack.
5. Raise or lower jacks as required to level the crane.

Note: As conditions warrant, a proficient crane operator may operate multiple jack cylinders such as one end or side at the same time.

Note: A bubble level is provided on the right side cab wall to assist in determining when the crane is level.

6. Check that all tires are clear of the ground and pontoons are not settling.



WARNING

All capacities listed in the Crane Rating Manual, when on outriggers, are based on all tires clear of the ground, all outrigger beams equally extended (fully retracted, intermediate extended, or fully extended), using the proper chart for the outrigger position and the crane setting level on a firm, solid surface. Major reductions in the crane lifting capacity and unsafe operating conditions can result if these conditions are not met.



To Retract Outrigger Jacks – Lower The Crane

1. Fully retract the boom. Swing the upper over the front of the carrier and engage the travel swing lock.
2. Fully boom down.



WARNING

Do not extend or retract an outrigger beam or jack unless it is in full view of the operator or signal person. Ensure all personnel and obstructions are clear from the path of the machinery.

3. Push an individual outrigger switch to the jack position  and hold.
4. Push the center mode switch to retract mode on position  and hold until the jack cylinder is fully retracted.
5. Release both switches.
6. Repeat Steps 3–5 for each outrigger jack.

Note: As conditions warrant, a proficient crane operator may operate multiple jack cylinders such as one end or side at the same time.

To Retract Outrigger Beams

1. Set the extend position levers in the fully retracted position. (Refer to Figure 1–61.)
2. Push an individual outrigger switch to the beam position  and hold.

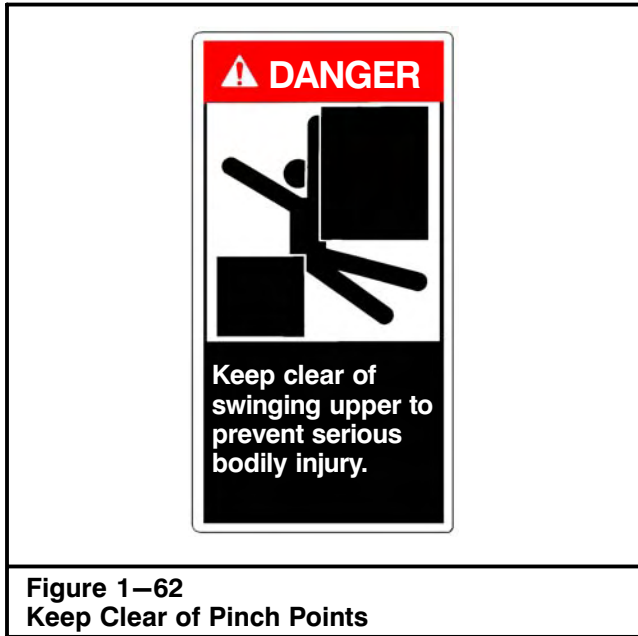

3. Push the center mode switch to the retract mode on position  and hold until the beam is fully retracted.
4. Release both switches.
5. Repeat Steps 1-4 for each beam.

Note: As conditions warrant, a proficient crane operator may operate multiple beams such as one end or side at the same time.

6. Store all pontoons in the brackets provided.

Crane System Controls

The following pages, along with Figure 1-64, give detailed instructions of individual controls related to crane operation. It is essential that the operator knows the function of each control and its duty in the overall operation of the crane.

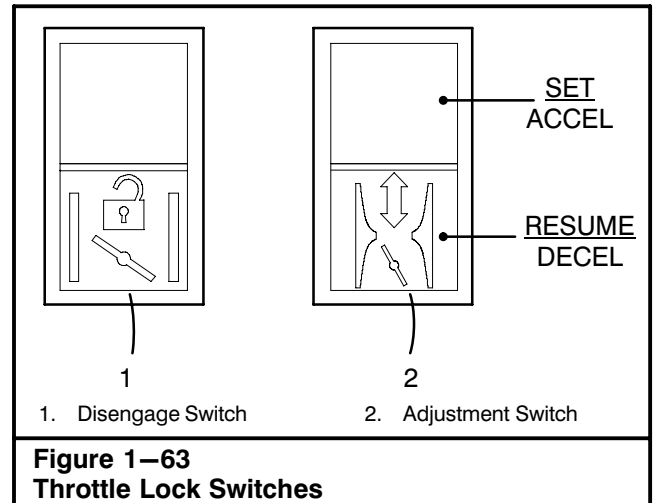
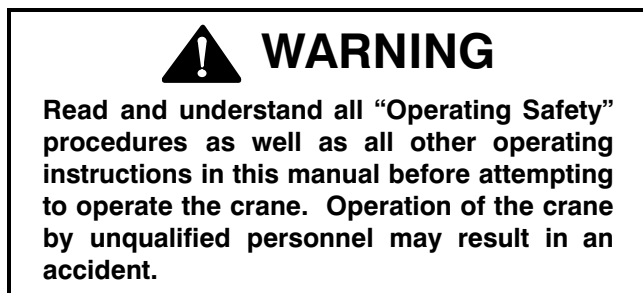

Engine Throttle

The crane is equipped with a throttle pedal to control the engine speed. Press pedal down to increase engine speed; release to decrease engine speed.

Throttle Lock System

To lock the throttle, press the throttle pedal until the desired engine speed is reached and press and release the adjustment switch to the "SET/ACCEL" side. Refer to Figure 1-63. The engine should continue to run at a constant speed when the throttle pedal is released.

To increase throttle lock setting, either press and hold the adjustment switch to the "SET/ACCEL" side until desired engine speed is reached and release switch, or press the throttle pedal until the desired engine speed is reached and press and release the adjustment switch to the "SET/ACCEL" side. The throttle lock setting can also be increased incrementally by pressing and releasing (tap up) the "SET/ACCEL" side.

To decrease throttle lock setting, press and hold the adjustment switch to the "RESUME/DECEL" side until desired engine speed is reached and release switch. The throttle lock setting can also be decreased incrementally by pressing and releasing (tap down) the "RESUME/DECEL" side.

To return to idle, press and release the bottom part of the disengage switch.

To resume a previous throttle lock setting, press and release the adjustment switch to the "RESUME/DECEL" side.

Note: The throttle lock system is deactivated anytime the ignition switch is turned off.

Operator's Manual

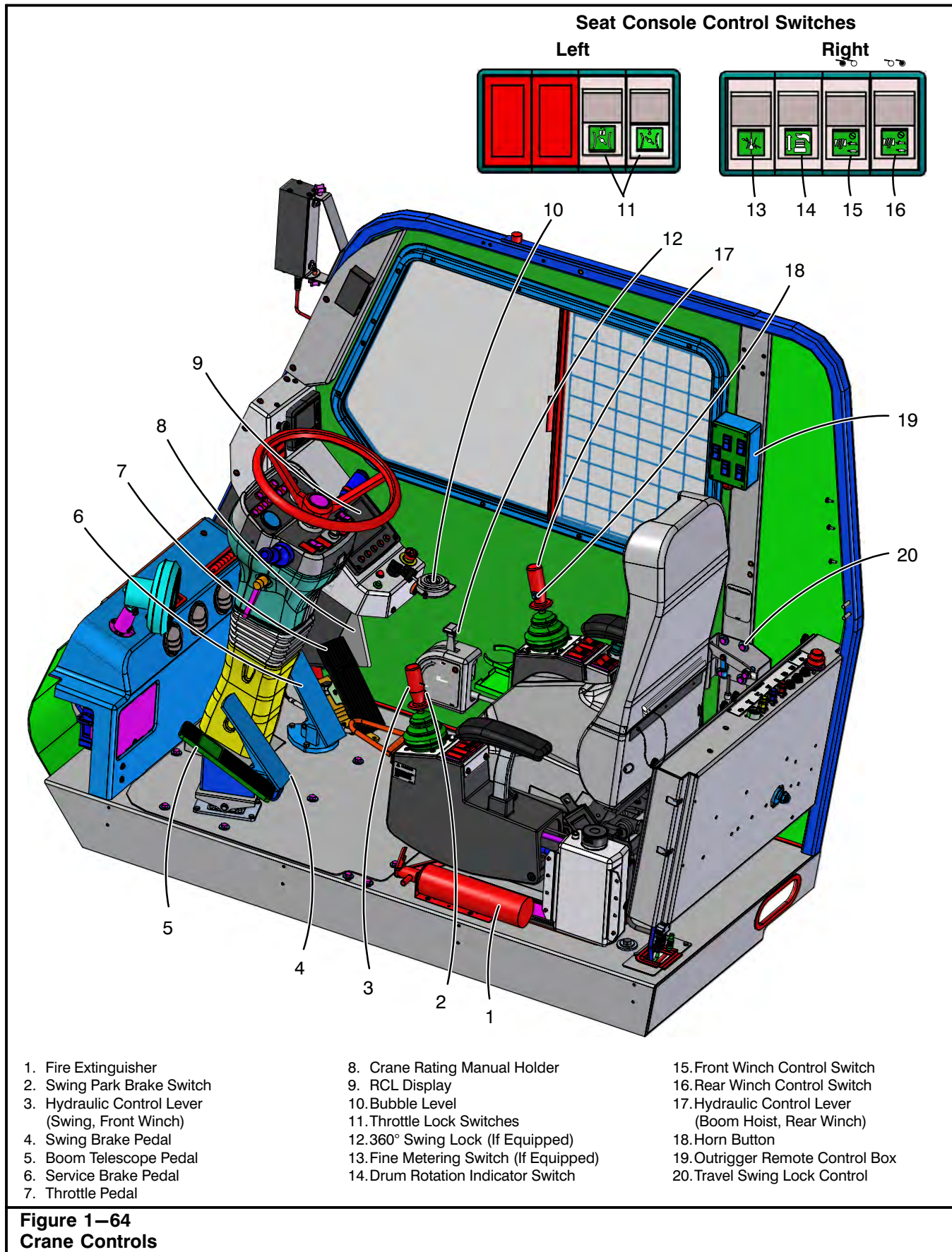

Figure 1-64
Crane Controls

Operator's Manual



Swing System

Rotation of the upper over the carrier is controlled by the swing system. Use the following controls to operate the swing function of the crane:

Swing Brake Pedal

The swing brake pedal is used to stop rotation of the upper over the carrier. To apply the swing brake, push down on the swing brake foot pedal. To release the swing brake, release the swing brake foot pedal.

Swing Control Lever

The control lever, on the left side of the operator's seat, is used to operate the swing function of the upper. Move the control lever to the  position to swing left; move it to the  position to swing right.



WARNING

Do not exceed maximum boom angles listed on the "Backward Stability – Maximum Boom Angle" chart in the Crane Rating Manual or the Backward Stability label in the operator's cab. Crane may tip over backwards causing personal injury and/or crane damage.

To Swing The Upper

1. Compare the boom configuration and length to the capacity chart in the Crane Rating Manual. Position the boom safely within the limits specified on the capacity chart.
2. Ensure that all personnel are out of the swing path. Dangerous pinch points are created during swinging.



DANGER

Swing slowly and cautiously. Watch for centrifugal force. Out swing of a load increases the load radius and thus decreases capacity. Load out swing may result in tipping or damaging the crane.

All personnel and equipment must be out of the path of the rotating upper. Failure to do so could result in severe personal injury or major equipment damage.

3. Fully apply the swing brake pedal and release the swing park brake and/or swing lock(s).
4. Release the swing brake pedal and begin to engage the swing control lever.

To Stop Upper Swing

1. Ease swing control lever into the neutral position.
2. Apply the swing brake to bring the upper to a complete stop.
3. Engage the swing park brake as required.
4. Check engagement of the swing park brake by trying to swing right, then left. The upper should not swing.

Travel Swing Lock

Use the travel swing lock to lock the upper directly over either the front or rear of the carrier. The travel swing lock will engage in these two positions only. Use of the travel swing lock is mandatory when traveling or transporting the crane and during pick and carry operations.

To Release The Travel Swing Lock

1. Fully apply the swing brake pedal.
2. Pull the travel swing lock lever up.

Note: In order to disengage the travel swing lock, it may be necessary to swing the upper slightly to relieve the pressure on the swing lock pin.

3. Move the lever to the right and release. The lever should remain in the released  position.

To Engage The Travel Swing Lock

1. Position the upper directly over either the front or rear of the carrier. Fully apply swing brake pedal.
2. Pull the travel swing lock lever up and to the left. Then push the lever down to the locked  position.

Note: In order to engage the travel swing lock, it may be necessary to swing the upper slightly to align the swing lock pin and retaining ring on the carrier deck.

3. Check the engagement of the travel swing lock by trying to swing the upper right, then left. The upper should not swing.

Operator's Manual

Swing Park Brake

The swing park brake is a multiple disc type brake and is used for holding the upper, in any position, over the carrier during normal, stationary crane operations. Engage the travel swing lock and release the swing park brake for pick and carry and anytime the crane is traveled or transported. An indicator light on the crane control display (Figure 1–41) will illuminate when the swing park brake is applied.

CAUTION

Do not leave the swing park brake applied during pick and carry operations or when traveling or transporting the crane. Use the travel swing lock. Failure to release the swing park brake during these operations may result in damage to the swing mechanism.

To Release The Swing Park Brake

1. Fully apply the swing brake pedal.

2. Push the top part of the swing park brake rocker switch on the left seat console to release the park brake. The indicator light will go out. Refer to Figure 1–64 for rocker switch and indicator light location.

To Apply The Swing Park Brake

1. Rotate the upper to the desired position over the carrier. Apply the swing brake pedal to bring the upper to a complete stop.

CAUTION

Do not attempt to apply swing park brake with the upper in motion. This practice will result in damage to the swing mechanism. Use the swing brake pedal to stop rotation of upper.

2. Push the bottom part of the swing park brake rocker switch on the seat console to apply the park brake. Indicator light will illuminate. Refer to Figure 1–64 for rocker switch and indicator light location.
3. Check engagement of swing park brake by trying to swing upper right, then left. Upper should not swing.

Operator's Manual

360° Swing Lock

The 360° swing lock, if equipped, is a positive lock against rotation of the upper over the carrier. The upper is mechanically locked by a manually operated pawl that engages the gear teeth in the turntable bearing. Use this swing lock during normal, stationary crane operations. Engage the travel swing lock and release the 360° swing lock anytime the crane is used for pick and carry or is traveled or transported.

CAUTION

Do not leave the 360° swing lock engaged during pick and carry operations or when traveling or transporting the crane. Use the travel swing lock. Failure to release the 360° swing lock during these operations may result in damage to the swing mechanism.

To Release The 360° Swing Lock:

1. Fully apply the swing brake pedal.

2. Move the 360° swing lock lever to the "Disengage" position.

To Engage The 360° Swing Lock:

1. Rotate the upper to the desired position over the carrier. Apply the swing brake pedal to bring the upper to a complete stop.

CAUTION

Do not attempt to engage 360° swing lock with the upper in motion. This practice will result in damage to the swing mechanism. Use swing brake pedal to stop rotation of the upper.

2. Move the 360° swing lock lever to the "Engage" position.

Note: In order to engage the 360° swing lock, it may be necessary to swing the upper slightly to allow the swing lock pawl to engage in the turntable gear teeth

3. Check engagement of 360° swing lock by trying to swing upper right, then left. The upper should not swing.

Operator's Manual

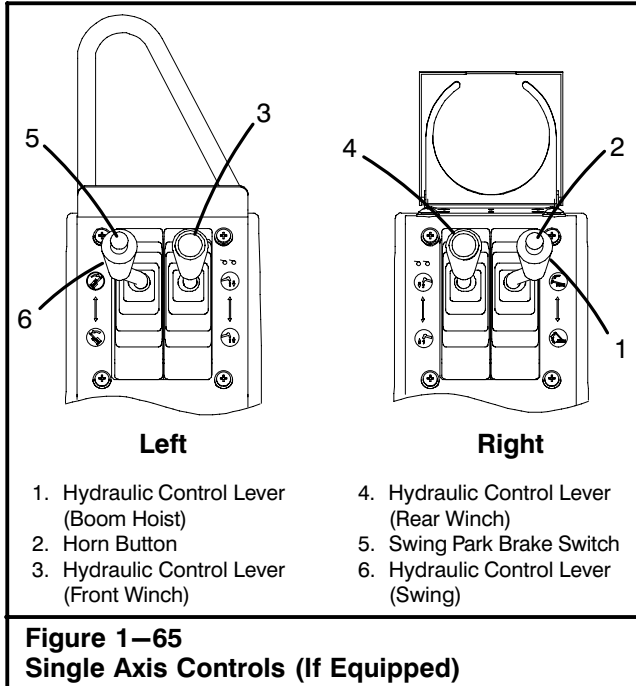

Wire Rope Winch System

This system controls raising and lowering the winch lines. The system is equipped with a two speed motor that, when activated, will approximately double winch line speed. The controls for the system are shown in Figure 1–64. Review the following for control descriptions and brief summary of operation.

CAUTION

When the hoist line is tied off to the crane or any solid object, the winch system can be overloaded causing major winch, wire rope, or crane damage. Do not extend boom, raise or lower the boom, or raise the crane on outriggers unless wire rope is spooled off the drum to prevent tension on the wire rope.



WARNING

Cold weather operation of the winch requires a warm-up procedure. Failure to properly warm-up the winch may result in brake slippage. Warm-up the winch before beginning crane operations.

Warm-Up Procedure

A warm-up procedure is recommended at each start-up and is essential at ambient temperatures below 40°F (4°C). Allow the engine to run at idle speed, with the main hydraulic pump engaged and the winch control lever(s) in neutral, for several minutes. Once the hydraulic oil begins to warm, operate the winch at low speed, with no load, lifting and lowering only the hook block or hook ball until warm oil circulates throughout the winch.





WARNING

The weight of the load must be known before making a lift. Compare the load weight to the appropriate capacity chart in the Crane Rating Manual to ensure compliance with capacity ratings. Compare the load weight to the Wire Rope Capacity chart in the Crane Rating Manual to determine the number of parts of line required to lift the load. Rig and set up the crane to ensure compliance with both the appropriate crane capacity chart and Wire Rope Capacity chart in the Crane Rating Manual. Properly set the Rated Capacity Limiter to the correct crane configuration.



Do not lift a load to the point where the hook block, hook ball and/or the load contacts the head machinery. "Two blocking" could damage the hook block, hook ball, wire rope, and/or the head machinery. Always keep the hook block, hook ball, and/or the load a safe distance from the boom.

Operator's Manual

Front Winch Control Lever (If Equipped)

This lever controls the front winch drum. Pull this control lever back to the  position to lift the load. Push this control lever forward to the  position to lower the load. Refer to "Winch Operation" for more specific instructions.

Rear Winch Control Lever

This lever controls the rear winch drum. Pull this control lever back to the  position to lift the load. Push this control lever forward to the  position to lower the load. Refer to "Winch Operation" for more specific instructions.

Winch Operation

The following is a brief description of the basic procedure for operating the wire rope winch. Crane operations are to be performed only by a qualified operator who has read and fully understands the entire content of this manual.

To Lift A Load: Attach the hook block or hook ball to the load. Position head machinery directly above the load, and pull the control lever back toward the operator.

Note: When both winch levers are activated simultaneously, the winch line requiring the most line pull may not function.



To Hold A Load: Return the control lever to the neutral position. The automatic brake in the winch system will hold the load in position.

To Lower A Load: Push the control lever forward. Return the control lever to neutral to stop the load.

Winch Control Switch(es)

This switch is used to control engaging/disengaging the high/low speed hoist and disabling the front or rear winch. Refer to Figure 1–64.

High Speed Hoist Or Lower



Move the control lever to the neutral position to bring the load to a complete stop. Press the winch control switch to the high speed () position. Move the control lever to the  or  position. The high speed hoist will activate after engaging the control lever. Refer to Figure 1–64.

Note: Using the high speed hoist reduces the maximum line pull by approximately one half. It is recommended that the high speed hoist button be activated before engaging the winch control lever(s).



WARNING

Do not activate the high speed hoist if the line pull exceeds the available high speed winch line pull. Crane damage can occur. Always refer to the Crane Rating Manual for the winch available line pulls before lifting or lowering any load.

To Return To Standard Winch Mode: Move the control lever to the neutral position to bring the load to a complete stop. Press winch control switch(es) to the low speed () position. Move the control lever to the  or  position. Standard winch mode will activate after engaging the control lever(s).

Winch Disable

Press the winch control switch(es) to the disable () position to disable the winch(es) to prevent inadvertent operation of the winch(es) while using the control levers to perform other operations.

Operator's Manual

Drum Rotation Indicators

This system is used to monitor winch drum speeds through the use of a mechanical signaling device mounted inside each of the winch control levers. To activate the system, push the bottom part of the drum rotation indicator switch , on the right seat console (Figure 1–64), to the “ON” position (indicator within switch will illuminate). Place your thumb over the end of the control lever being used. As the winch drum rotates, a mechanical signal will be felt with your thumb. The frequency of the mechanical signal is a direct indication of the winch drum speed. Push the top part of the drum rotation switch to deactivate system.

First Layer/Third Wrap Indicator (If Equipped)

The crane may be equipped with a first layer/third wrap warning system. This system allows the operator to monitor the wire rope windings on the drum(s). An audible alarm will sound intermittently and “First Layer” will appear in the warning message area of the RCL Display to alert the operator that the wire rope is down to the first layer on the winch drum(s). When the wire rope is down to the third wrap on the winch drum(s), an audible alarm will sound continuously, and “Third Wrap” will appear in warning message area on the RCL Display. If enabled and activated, the winch function will also cutout with the third wrap alarm. Refer to First Layer/Third Wrap Calibration in Section 3 of this Operator's Manual for calibration procedures.



WARNING

Three (3) full wraps of wire rope must be maintained on the winch drum(s) at all times during operation. Wire rope failure may occur.

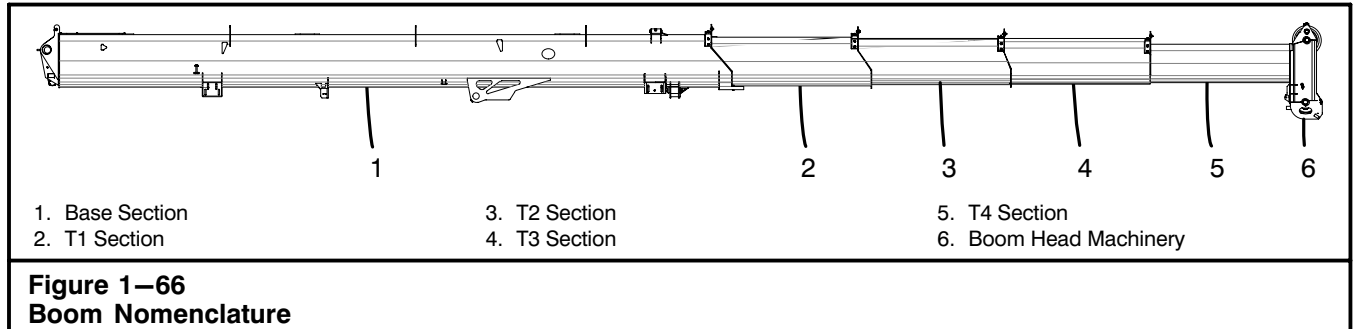

Boom Hoist System

Raising and lowering the boom is controlled by the boom hoist control lever on the right arm rest. Refer to Figure 1-64.



WARNING

Do not exceed maximum boom angles listed on the “Backward Stability – Maximum Boom Angle” chart in the Crane Rating Manual or the Backward Stability label in the operator’s cab. Crane may tip over backwards causing personal injury and/or crane damage.

To Raise The Boom (Boom Up): Move the right control lever to the  position.

CAUTION

When the hoist line is tied off to the crane or any solid object, the winch system can be overloaded causing major winch, wire rope, or crane damage. Do not extend boom, raise or lower the boom, or raise the crane on outriggers unless wire rope is spooled off the drum to prevent tension on the wire rope.

To Lower The Boom (Boom Down): Move the right control lever to the  position.

CAUTION

Wire rope must be spooled off the winch drum as the boom is lowered. Failure to do so may cause two blocking.

To Stop The Boom: Ease the right control lever into the neutral position.

Boom Telescope System

The crane is equipped with a five section boom. The five section boom consists of a base, T1, T2, T3, and a T4 section. Refer to Figure 1-66.

One telescope cylinder and one pin/latch cylinder are used to sequentially telescope one section at a time and pin that section to the next adjacent section in one of 3 positions: 0%, 50%, or 100% extension for each section. The operation of these cylinders is a combination of computer control and operator input. The computer controls which section is being extended or retracted, all pinning and unpinning operations, direction, and in some cases the speed of the telescope cylinder. The operator controls whether to extend or retract the boom and the speed at which to extend or retract the boom.

The telescope feature has three modes of operation (Refer to Figure 1-67):

- EM1 extends all sections 100% for a max boom length of 140 ft (42.7m).
- EM2 extends only the T1, T2, and T3 to 100% for a max boom length of 115.8 ft (35.3m). T4 section remains fully retracted.
- EM3 extends T1, T2, and T3 to 50% for a maximum boom length of 76.5 ft (23.3m). The T4 section remains fully retracted. Maximum rated capacities are only available when all the sections are pinned together or the boom is fully extended.

Note: When utilizing the EM3 boom mode, ensure the boom sections are pinned together or are at the maximum length for boom mode EM3 before lifting the allowable capacity loads. Utilize the boom pinning information in boom telescope animation display on the RCL main working screen to confirm a “Pinned” condition.

There is a 10,000 lb (4 536kg) capacity allowed only for the weight of the rigging while telescoping the boom between fixed boom lengths. Do not attempt to extend or retract the boom with more than 10,000 lb (4 536kg) of rigging while utilizing boom mode EM3.

Operator's Manual

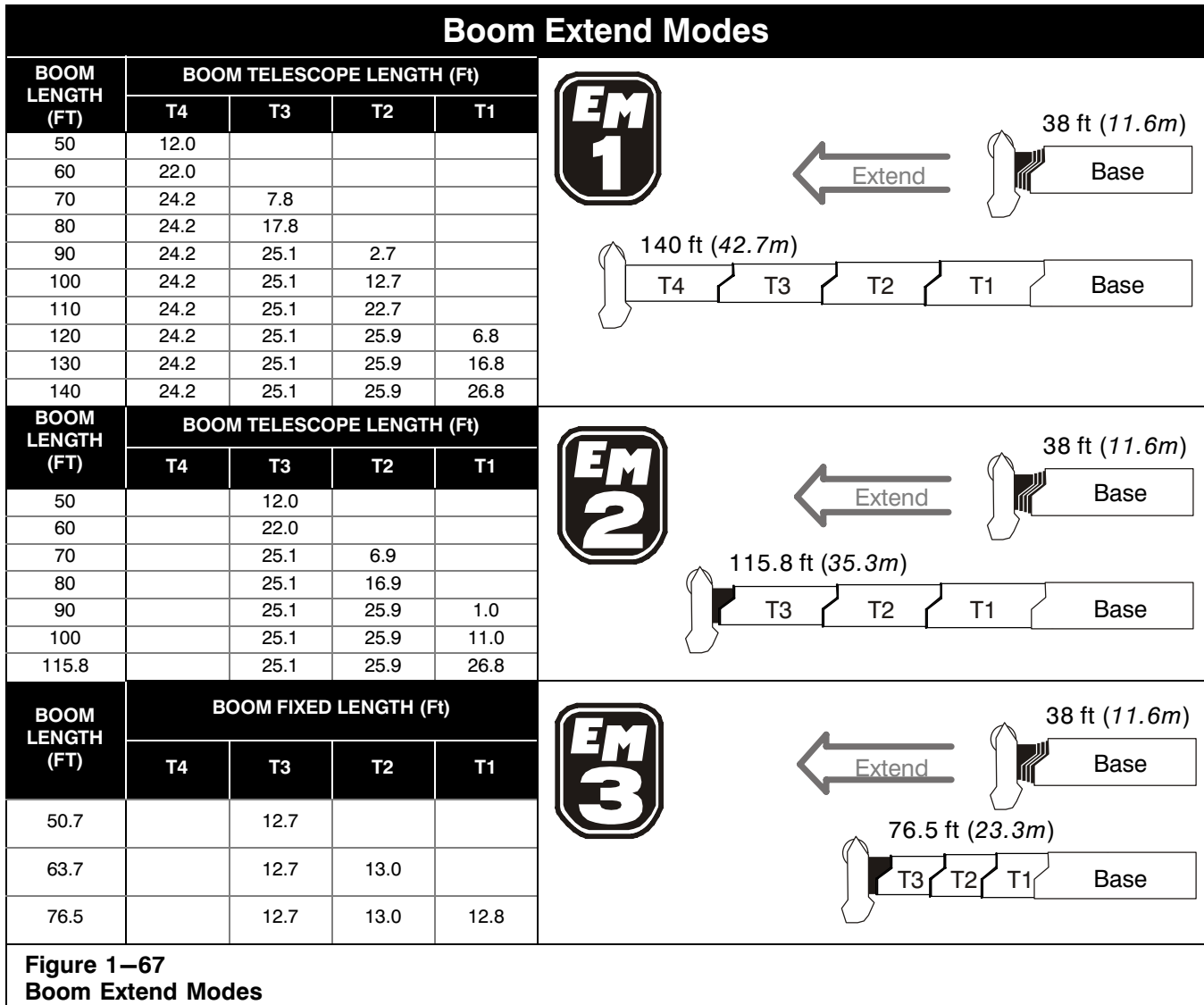

Figure 1–67
Boom Extend Modes

Boom Telescope Mode Selection

The boom modes can be changed only when the boom is fully retracted. If a boom mode change is attempted before the boom is fully retracted, the message “Retract Boom” will be displayed and the boom mode will not change. To change or select a boom mode, refer to “Rated Capacity Limiter” in this Section of this Operator’s Manual. When a boom mode is selected, the telescope controller’s first command

requires the telescope pedal to be pressed and held to move the telescope cylinder into alignment with the first boom section that is to be extended for the boom mode selected.

This movement of the telescope cylinder must be allowed to finish before any other telescope function can happen. Be patient and allow the system to complete these functions before attempting other functions.

Operator's Manual

Boom Telescope Control Pedal

The telescope control pedal is in the left front of the operator's cab floor. Refer to Figure 1–64. Depress the toe of the telescope control pedal to extend the boom. Depress the heel of the telescope control pedal to retract the boom.

To Extend The Boom Sections

1. Park the crane on a firm level surface, engage the park brake, and shift the transmission to neutral.
2. Review the appropriate capacity chart in the Crane Rating Manual to establish boom length, angle, and load limitations.
3. Set the Rated Capacity Limiter to the desired telescope mode. Refer to "Rated Capacity Limiter" in this Section of this Operator's Manual.

Note: Mode changes can only be made when the boom is fully retracted. When a mode change is selected, the computer requires the telescope pedal to be pressed and held to move the telescope cylinder to line up with the first section to be extended. Allow this operation to finish before continuing. If a boom mode change is attempted before boom is fully retracted, the message "Retract Boom" will be displayed in the Boom Controller Message area on the RCL main working screen and the boom mode will not change.

CAUTION

When the hoist line is tied off to the crane or any solid object, the winch system can be overloaded causing major winch, wire rope, or crane damage. Do not extend boom, raise or lower the boom, or raise the crane on outriggers unless wire rope is spooled off the drum to prevent tension on the wire rope.

CAUTION

Wire rope must be spooled off the winch drum(s) as the boom is extended. Failure to do so may cause two blocking.

4. Depress the toe of the telescope control pedal to extend the boom. Allow time for the telescope cylinder to latch to the correct section and pull the pin between sections. The computer will then accelerate the boom section up to a speed proportional to the amount the telescope pedal is depressed. Releasing the pedal will stop telescope operation.

Note: The telescope control pedal is spring loaded and should return to the neutral position when released.

Note: In very cold weather, the latch and pin cylinder will not function as fast as normal due to the change in the viscosity of the hydraulic oil. Allow extra time for this function in very cold weather.

5. Depressing the toe of the pedal will begin telescoping. When the section nears the point where the section will be pinned to the adjacent section, the computer automatically slows down the speed of the telescope cylinder. It is not necessary to remove your foot from the pedal or reduce the amount the pedal is depressed, this is done automatically. The section will actually be extended slightly past the pinning point and then slowly reverse direction to gently load up the pin and unload the latches that attach the telescope cylinder to the section being extended.

Note: The boom telescope animation display on the RCL main working screen provides visual feedback about what is occurring while telescoping the boom. Refer to Rated Capacity Limiter System in this Section of the Operator's Manual for normal boom operation and fault messages.

CAUTION

If a load is suspended while telescoping, the load will lower slightly during the pinning operation. This is more noticeable with a single part of line.

6. Continue to depress the toe of the telescope control pedal until the desired boom length is achieved. When the desired boom length is achieved release the telescope control pedal.

To Retract The Boom Sections

1. Depress the heel of the telescope control pedal.

Note: As the boom is retracted, the hook block or hook ball will lower. Winch up as required to keep the hook block or hook ball in the desired position.

Note: In very cold weather, the latch and pin cylinder will not function as fast as normal due to the change in the viscosity of the hydraulic oil. Allow extra time for this function in very cold weather.

Boom Operating And Error Messages

The boom controller message area on the RCL main working screen will display normal boom operating messages and any active error message. Refer to "Rated Capacity Limiter System" in this Section.

Operator's Manual

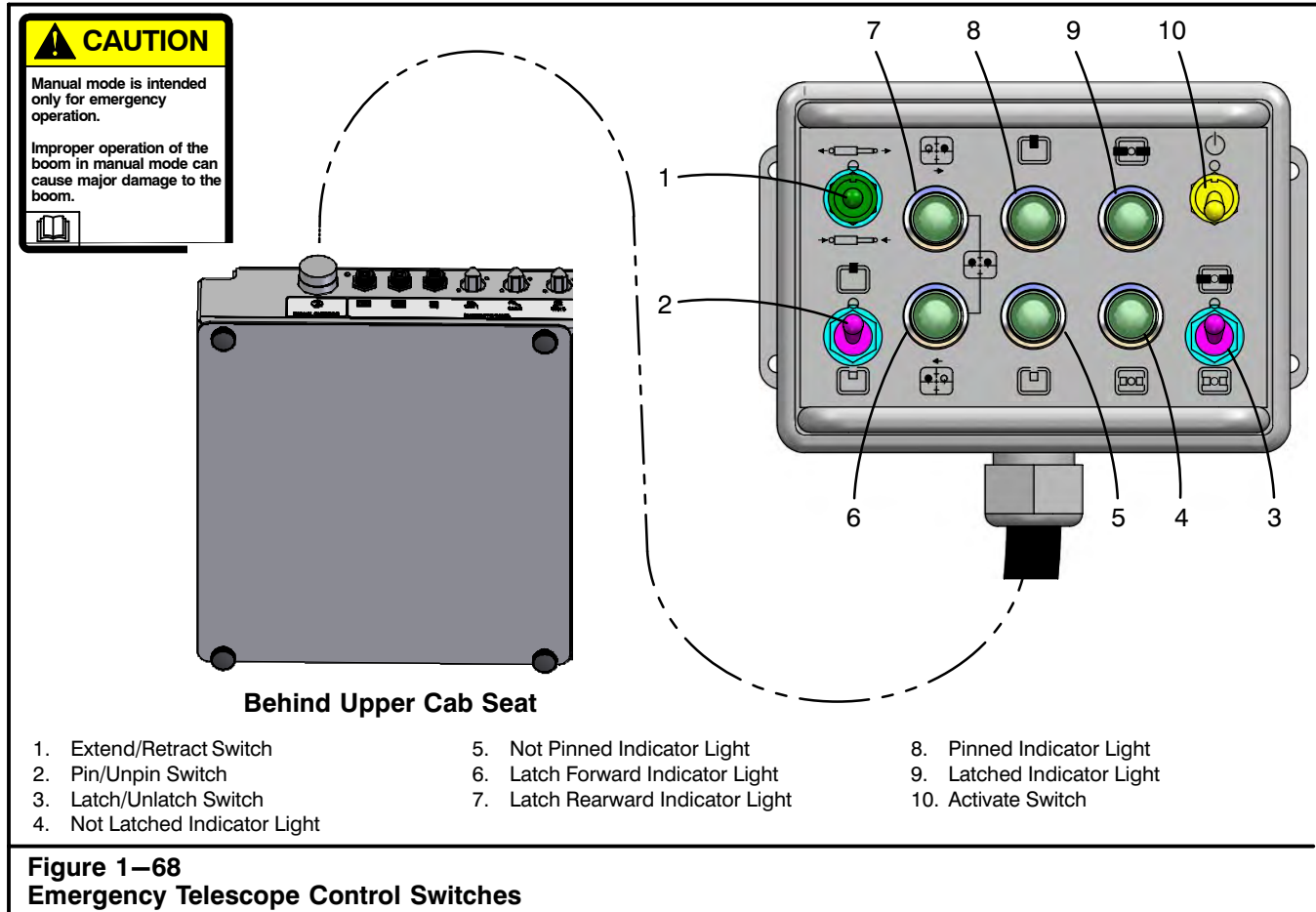

Emergency Telescope Operation

WARNING

Manual mode is intended for emergency operation and service requirements only. Improper operation of the boom in manual mode can damage internal components of the boom. This can lead to crane damage, property damage, or possibly personal injury.

The crane has been designed with the ability to telescope the boom manually. This is intended only for emergency operations and service requirements. Note the following restrictions:

- Do not telescope the boom in manual mode with a load on the hook. Set the load down before telescoping.
- Use the holes provided in the side of each boom section to visually check to ensure that pins and latches are fully engaged or disengaged before moving boom sections or the telescope cylinder.
- Clear all unauthorized personnel from the area surrounding the crane. Ensure that all authorized personnel are well out of the way of all moving parts.

The emergency telescope control switches are on a boom telescope remote control box stored in the tool box under the operator's seat. To enable the switches, connect the cord to the electrical connector on the lower right corner of the operator's cab. To enable the extend/retract and pin/latch switches, move and hold the activate switch to the "ACTIVATE" (I) position. Refer to Figure 1–68.

WARNING

When the emergency telescope control box is connected to the upper, the RCL System automatically changes to rigging mode. The RCL System is not operational when in the rigging Mode. Disconnect the remote control box, turn the ignition switch to the "OFF" position, and return the RCL System to normal operation before operating the crane.





When the emergency telescope control box is connected to the upper, the RCL System automatically changes to the rigging mode. All function limiters except anti-two block are disabled when the RCL is in the rigging mode.

To Manually Retract A Boom Section











WARNING

Manual mode is intended for emergency operation and service requirements only. Improper operation of the boom in manual mode can damage internal components of the boom. This can lead to crane damage, property damage, or possibly personal injury.

1. If the telescope cylinder is not already latched to the section to be retracted, push the Pin/Unpin switch to the PIN  position and visually check to ensure the pin cylinder is all the way up. PINNED indicator light  should illuminate.
2. Push the Latch/Unlatch switch to the UNLATCH  position and visually check to ensure that the telescope cylinder is not latched to a section. NOT LATCHED indicator light  should illuminate.
3. Push the Extend/Retract switch to telescope the cylinder until the latches are centered with the holes in the rear of the section to be retracted. The LATCH FORWARD and LATCH REARWARD indicator lights will illuminate when the latches are centered with the holes in the rear of the section. Refer to the following chart for approximate telescope cylinder positions.

| Extend Mode | Boom Length | Telescope Cylinder Length |
|-------------|-------------|---------------------------|
| | ±0.25 ft | ±0.25 in |
| EM1 | 140.0 | 322.9 |
| | 113.2 | 322.9 |
| | 87.3 | 322.9 |
| | 62.2 | 322.9 |
| EM2 | 115.8 | 322.9 |
| | 89.0 | 322.9 |
| | 63.1 | 322.9 |
| EM3 | 76.5 | 155.0 |
| | 63.7 | 167.7 |
| | 50.7 | 175.3 |

4. Push the Latch/Unlatch switch to the LATCH  position and visually check to ensure that the latches have fully engaged the section. LATCHED indicator light  should illuminate.
5. Push and hold the Extend/Retract switch to telescope the cylinder in or out slightly as needed to allow the latches to fully engage the section if the latch light does not illuminate.
6. When the latches are fully engaged (LATCHED indicator light illuminated), telescope the cylinder out approximately 3 inches (7.62cm) to unload the pin.
7. Push the Pin/Unpin switch to the UNPIN  position and visually check to ensure that the pin has fully disengaged from the adjacent boom section. The pin will pull when it is unloaded. NOT PINNED indicator light  should illuminate.
8. When the pin is pulled, the section can be retracted. Winch up while retracting the section to maintain tension on the wire rope so it will spool correctly.
9. When the section is fully retracted, push the Pin/Unpin switch to the PIN  position. PINNED indicator light  should illuminate.
10. Extend or retract the cylinder until the LATCH FORWARD and LATCH REARWARD indicator lights illuminate. Push the Latch/Unlatch switch to the UNLATCH  position and visually check to ensure that the latches are fully disengaged from the section before retracting another section. NOT LATCHED indicator light  should illuminate.
11. Repeat this operation until boom is fully retracted.
12. Disconnect remote control box and return the RCL System to normal operation before operating the crane.





Operator's Manual

To Manually Extend A Boom Section







WARNING

Manual mode is intended for emergency operation and service requirements only. Improper operation of the boom in manual mode can damage internal components of the boom. This can lead to crane damage, property damage, or possibly personal injury.



1. If the telescope cylinder is not already latched to the section to be extended, push the Pin/Unpin switch to the PIN  position and visually check to ensure the pin cylinder is all the way up. PINNED indicator light  should illuminate.
2. Push the Latch/Unlatch switch to the UNLATCH  position and visually check to ensure that the telescope cylinder is not latched to a section. NOT LATCHED indicator light  should illuminate.
3. Push the Extend/Retract switch to telescope the cylinder until the latches are centered with the holes in the rear of the section to be extended. The LATCH FORWARD AND LATCH REARWARD indicator lights will illuminate when the latches are centered with the holes in the rear of the section. Refer to the following chart for approximate telescope cylinder positions.

| Extend Mode | Boom Length | Telescope Cylinder Length |
|-------------|-------------|---------------------------|
| | ±0.25 ft | ±0.25 in |
| EM1 | 38.0 | 33.0 |
| | 62.2 | 22.0 |
| | 87.3 | 11.7 |
| | 113.2 | 1.0 |
| EM2 | 38.0 | 22.0 |
| | 63.1 | 11.7 |
| | 89.0 | 1.0 |
| EM3 | 38.0 | 22.0 |
| | 50.7 | 11.7 |
| | 63.7 | 1.0 |



4. Push the Latch/Unlatch switch to the LATCH  position and visually check to ensure that the latches have fully engaged the section. LATCHED indicator light  should illuminate.
5. Push the Extend/Retract switch to telescope the cylinder in or out slightly as needed to allow the latches to fully engage the section if the latch light does not illuminate.
6. When the latches are fully engaged (LATCHED indicator light illuminated), retract the cylinder until it bottoms out to unload the pin.
7. Push the Pin/Unpin switch to the UNPIN  position and visually check to ensure that the pin has fully disengaged from the adjacent boom section. The pin will pull when it is unloaded. NOT PINNED indicator light  should illuminate.

CAUTION

Wire rope must be spooled off the winch drum(s) as the boom is extended. Failure to do so may cause two blocking.

8. When the pin is pulled the section can be extended. Winch down while extending the section to avoid two blocking.
9. At the telescope cylinder length on the chart below, push the Pin/Unpin switch to the PIN  position and continue to extend the boom section until the pin engages into the hole. PINNED indicator light  should illuminate.

| Extend Mode | Boom Length | Telescope Cylinder Length |
|-------------|-------------|---------------------------|
| | ±0.25 ft | ±0.25 in |
| EM1 | 140.0 | 322.9 |
| | 113.2 | 322.9 |
| | 87.3 | 322.9 |
| | 62.2 | 322.9 |
| EM2 | 115.8 | 322.9 |
| | 89.0 | 322.9 |
| | 63.1 | 322.9 |
| EM3 | 76.5 | 155.0 |
| | 63.7 | 167.7 |
| | 50.7 | 175.3 |

10. Visually check to verify that the pin has fully engaged the pin hole. If it has not engaged the pin hole, telescope the cylinder in the direction required to align the pin with the hole.
11. Retract the cylinder to load up the pin. If this is done at a high boom angle further retraction of the cylinder will unload the latches and allow them to disengage from the section. If this is done at a low boom angle, the cylinder must be extended slightly to unload the latches and allow them to disengage from the section.
12. Push the Extend/Retract switch to telescope the cylinder until the latches are centered with the holes in the rear of the section to be extended. The LATCH FORWARD and LATCH REARWARD indicator lights will illuminate when the latches are centered with the holes in the rear of the section.
13. Push the Latch/Unlatch switch to the UNLATCH  position and visually check to ensure that the telescope cylinder is not latched to a section. NOT LATCHED indicator light  should illuminate.
14. When the cylinder is disengaged from the section, it can be retracted to align with the next section to be extended and the process can be repeated to extend other boom sections as required.
15. Disconnect remote control box and return the RCL System to normal operation before operating the crane.

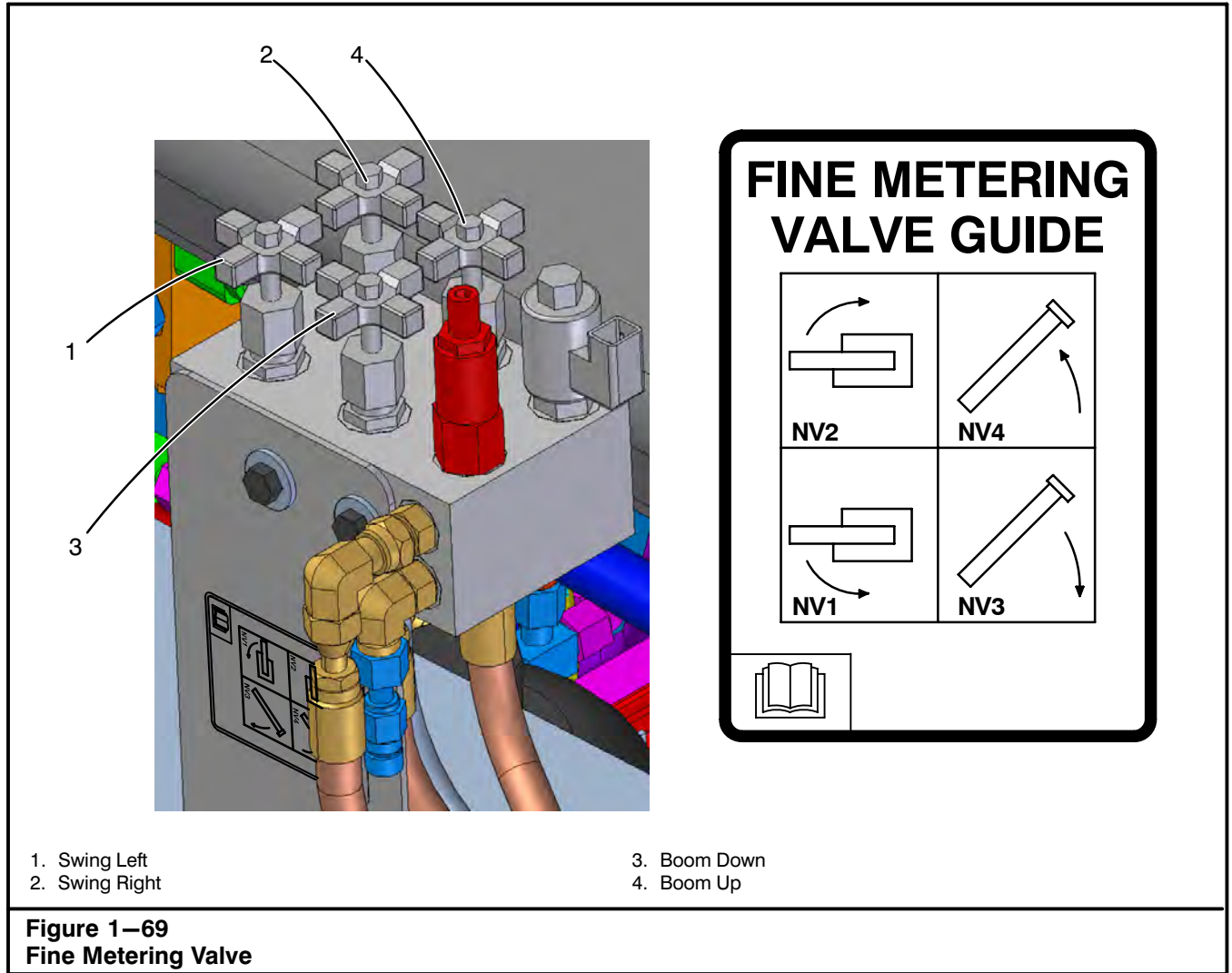

Fine Metering System (If Equipped)

This fine metering system is used to adjust the crane's hydraulic functions to certain job functions or for set-

tings that are comfortable to the operator. The system is for precise controlled operation and heavy lift capacity with slower speed. Use for jobs where accurate positioning is more important than speed. The system is activated by the fine metering switch on the right seat console. Refer to Figure 1-40 for switch location.

Operator's Manual

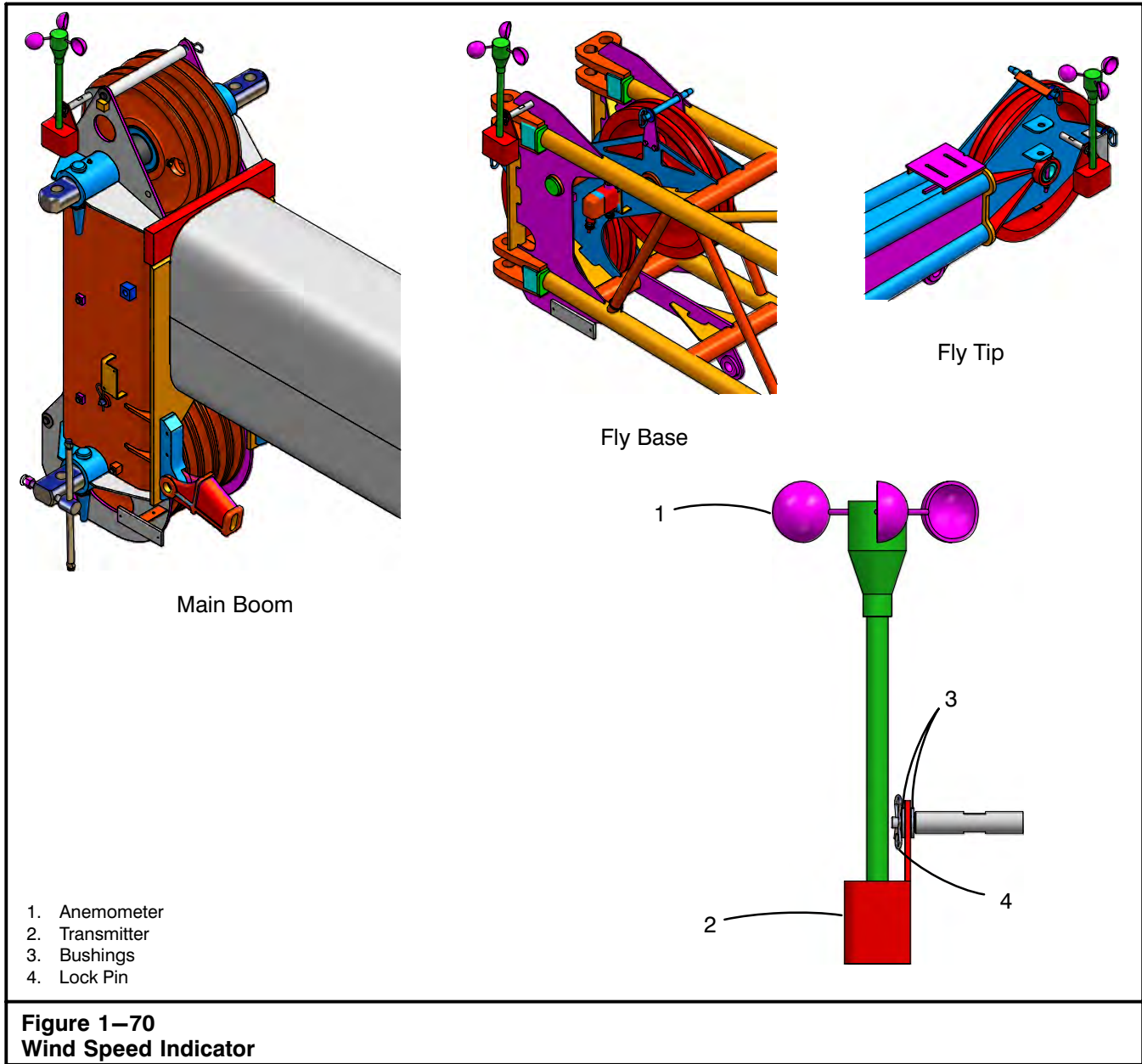

Crane Monitoring System

A crane monitoring system is available to assist the operator in safe operation of the crane. The following systems outline some of the aids used for monitoring crane conditions during operation.

Wind Speed Indicator

The crane may be equipped with a wireless wind speed indicator integrated into the Rated Capacity Limiter System. The indicator is used to monitor wind speeds at the main boom head or the fly head when

erected. Refer to Figure 1–70. An anemometer transmits wind speed data to the display unit in the operator's cab. Refer to "Wind Speed Restrictions" in the Crane Rating Manual for more information on wind speed restrictions.

CAUTION

Remove the anemometer assembly from the boom head or fly during transport to prevent damage to the unit.

Operator's Manual

Operating In Wind And Lightning

Avoid working a crane in high winds and when there is a likelihood of lightning. Rated lifting capacities do not account for the effects of wind on a suspended load or boom. Lifting capacities should be considered acceptable for wind speeds up to 20 mph (32km/h) and appropriately reduced for wind speeds greater than 20 mph (32km/h). If you must work in a wind, reduce capacities to those listed in "Wind Speed Restrictions" chart in the Crane Rating Manual. Wind blowing against the load and the boom produces a side load on the boom and reduces its capacity. When lifting loads which have large surface areas in a wind, such as building panels, the movement of the load may pose a danger to workmen or building structures. Out swing of a load will increase the load radius, and may over-

load the crane. This could lead to boom failure or the crane tipping. Monitor the wind speed using the wind speed indicator. Stop lifting operations, ground the load, fully retract and lower the boom to horizontal if wind speed exceeds the maximum allowed listed in "Wind Speed Restrictions" chart in the Crane Rating Manual. Use the following table as a general guide.



DANGER

If there is a likelihood of lightning, immediately stop lifting operations, ground the load, and fully retract and lower the boom in the boom rest. Severe injuries or death could result.

| Wind Scale | | | | |
|-------------------|------------------|-----------------------|-------------------------|---|
| Wind Speed | | Wind Strength | | Inland Wind Effect |
| mph | km/h | Beaufort Scale | WMO* Description | |
| <0.6 | <1 | 0 | Calm | Calm, smoke rises vertically. |
| 0.6 to 3.1 | <i>1 to 5</i> | 1 | Light Air | Smoke drift indicates wind direction, wind vanes remain still. |
| 3.7 to 6.8 | <i>6 to 11</i> | 2 | Light Breeze | Wind felt on face, leaves rustle, wind vanes begin to move. |
| 7.4 to 11.8 | <i>12 to 19</i> | 3 | Gentle Breeze | Leaves and small twigs constantly moving, light flags extended. |
| 12.4 to 17.4 | <i>20 to 28</i> | 4 | Moderate Breeze | Dust, leaves, and loose paper lifted, small tree branches move. |
| 18.0 to 23.6 | <i>29 to 38</i> | 5 | Fresh Breeze | Small trees in leaf begin to sway. Crested waves form on inland waters. |
| 24.2 to 30.4 | <i>39 to 49</i> | 6 | Strong Breeze | Larger tree branches moving. Telegraph wires whistle. Umbrellas used with difficulty. |
| 31.1 to 37.9 | <i>50 to 61</i> | 7 | Near Gale | Whole trees moving. Resistance felt walking against wind. |
| 38.5 to 46.0 | <i>62 to 74</i> | 8 | Gale | Breaks twigs off trees. Resistance felt walking against wind. |
| 46.6 to 54.1 | <i>75 to 87</i> | 9 | Strong Gale | Slight structural damage. Slate blows off roofs. |
| 54.7 to 62.8 | <i>88 to 101</i> | 10 | Storm | Trees broken or uprooted. Considerable structural damage. |

* World Meteorological Organization

Operator's Manual

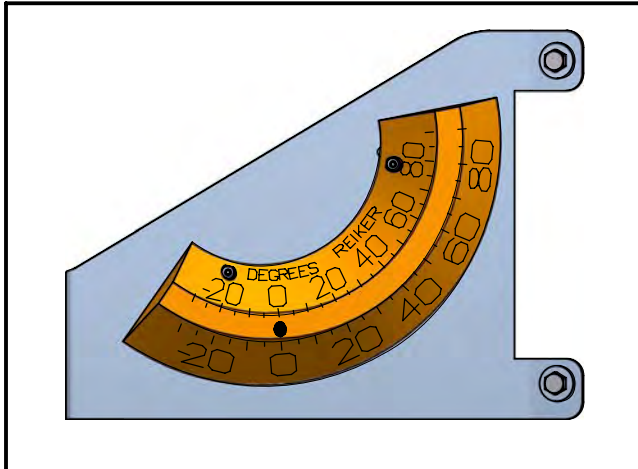

Figure 1-71
Boom Angle Indicator

Boom Angle Indicator

A bubble type boom angle indicator is mounted to the right of the operator's cab on the base section of the boom. Refer to Figure 1-71. It must be adjusted properly and the crane must be level for the unit to accurately indicate boom angles. Even under these conditions its readings are only approximate. When making near capacity lifts, measure the load radius to determine crane capacity. Check the adjustment of the boom angle indicator daily to ensure its accuracy. Refer to "Boom Angle Indicator Adjustment" in Section 3 of this Operator's Manual.

Anti-Two Block Warning System

Integrated into the Rated Capacity Limiter System is an anti-two block (ATB) warning system. An anti-two block warning system is an electromechanical system designed to alert the operator before the hook block or hook ball contacts the head machinery of the main boom, auxiliary lifting sheave, or fly. When a two block situation is imminent, an audio/visual alarm is activated to alert the operator of the pending danger. When the alarm activates it is essential that the operator discontinue operations immediately, and correct the two-block situation.

Three basic components are used to make up the anti-two block system. The anti-two block weight, anti-two block switch with lockout clip, and the display unit in the operator's cab. Refer to Figure 1-72 and Figure 1-74.

An anti-two block weight is suspended from the head machinery switch(es) where lifts are to be made and is used to hold the switch(es) in the "working" position. When the anti-two block weight is lifted by the hook block or hook ball, it allows the switch to activate the audio/visual alarm on the display unit in the operator's cab. In addition to the audio/visual alarm, function limiters will be activated.

CAUTION

Do not allow the load to spin out of control when hoisting. The anti-two block weight may become entangled with the wire rope and could damage the anti-two block system, wire rope, or boom. Use rotation resistant wire rope during single part line hoisting applications, especially when long fall lifts are involved.

The added feature of hydraulic function limiters, prevents the operator from continuing crane functions which will cause a two block situation to occur. The crane functions of winch up, boom down, and boom extend are disabled when the anti-two block weight is lifted. These functions will remain disabled until the two block situation is corrected or the "Cancel Alarm" button on the display unit is pressed and held to override the system.

Note: Push the "Cancel Alarm" button momentarily once to silence the audible alarm. Press and hold the "Cancel Alarm" button for 2 seconds or longer to temporarily override the system.

The main boom head must always have an anti-two block switch. Each of the added attachments used on the crane must employ a similar head machinery switch as well, in order for that particular attachment to be monitored by the system.

The plug assembly is connected to the jumper assembly on the boom head when operating from the main boom. It is connected to the jumper assembly on the attachment when operating from that attachment.

Check that all the harness connections between the attachments are properly connected and test the system before beginning operations. Test the system by manually lifting the ATB weight and verifying that the functions of winch up, boom down, and boom extend are disabled.

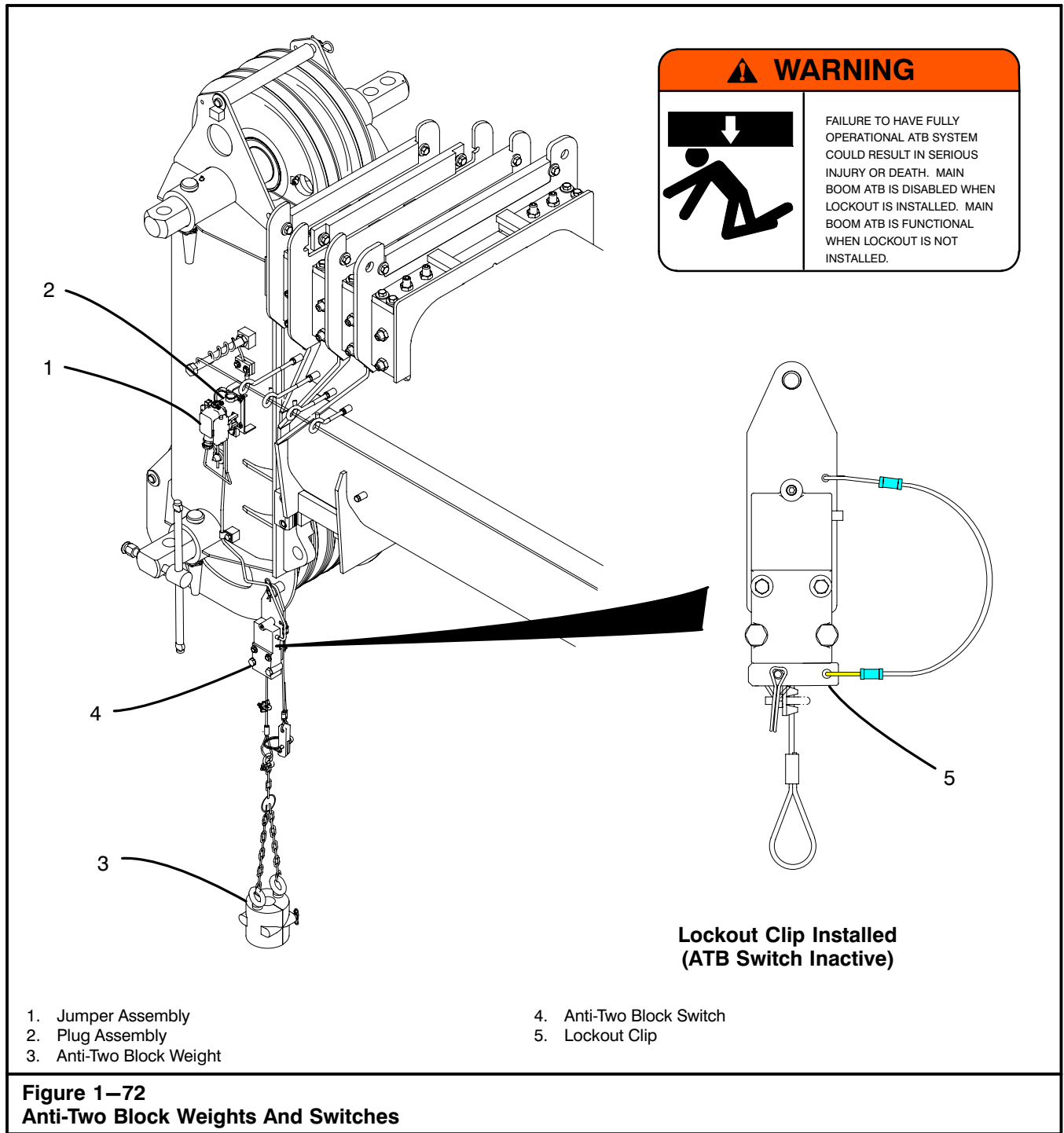

Lockout Clip

The lockout clip is used to hold the main boom anti-two block switch in the “working” position, the same as having a two block weight suspended from the switch.

When operating from the main boom the lockout clip must be removed from the anti-two block weight cable. When operating from an attachment only, the lockout clip must be installed on the anti-two block weight cable.

When both main boom and any attachment are reeved for operation, the lockout clip must be removed from the anti-two block weight cable.

Note: When using main boom and any attachment, an anti-two block weight must be suspended from the anti-two block switch on the main boom and on each attachment.

Operator's Manual

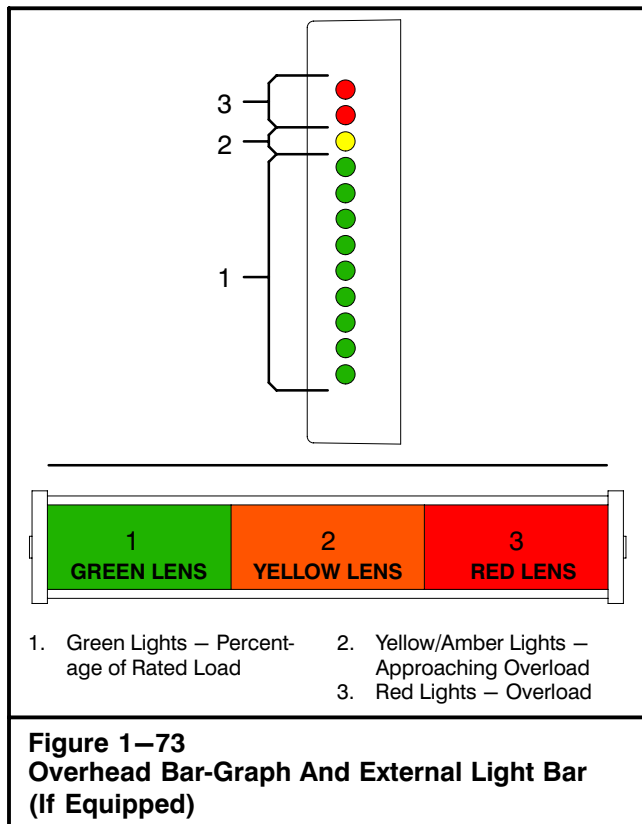

Rated Capacity Limiter

The following describes the function and operation of the Rated Capacity Limiter. The system is intended to aid the operator in the efficient operation of the crane by continually monitoring the load and warning of an approach to an overload or unsafe condition.

WARNING

Although the system will alert the operator of an approaching overload or unsafe condition, it remains the responsibility of the operator to operate the crane safely at all times.

This system must never be substituted for the good judgment of the crane operator using safe operating procedures. The operator is solely responsible for safe operation of the crane.

!!THIS SYSTEM IS AN OPERATOR'S AID – NOT A SAFETY DEVICE!!

System Description

The system monitors crane functions by means of high accuracy sensors and continuously compares the load with a copy of the crane capacity chart which is stored in the computer memory. If an overload is approached, the system warns by means of audible and visual alarms and is configured to cause function limitation.

The Rated Capacity Limiter provides the operator with a continuous display of:

- Rated Capacity
- Actual Load
- Radius of the Load
- Angle of the Main Boom
- Crane Configuration
- Length of the Main Boom
- Height of the Main Boom Head Above the Carrier Deck

Note: The function of the RCL System is an operational aid to warn or to indicate to the operator when the load being lifted approaches, meets, or exceeds the rated capacity of the crane. The RCL System does not function as a scale or weighing device.

The actual load displayed by the RCL System is less accurate when the actual load lifted is a small percentage of the allowable load. This typically occurs when lifting light loads with a short boom length at high boom angles. Crane configurations of this type produce low pressures in the boom hoist cylinder resulting in less accuracy of the RCL sensors and calculated load. The RCL load accuracy improves greatly when the actual load lifted approaches the rated load (higher boom hoist cylinder pressures).

An additional feature of the system is the provision of operator alarms. These alarms, when properly set, provide a method of obstacle avoidance. This is achieved by means of maximum boom length, maximum boom angle, maximum load radius, maximum boom head height, left and right swing, and defined area alarms. These alarms can be programmed for each job site and set rapidly for the prevailing site conditions thereby aiding the operator in safe operation of the crane.

Display Unit

The following is a description of the control buttons, indicators, and windows on the display unit. Use them along with Figure 1–74.

1. Bar-Graph

The Bar-Graph is a series of twelve colored lights which gives a visual indication of how much of the crane's capacity is being used and the rate at which an overload is being approached. Each green light represents 10% of the crane's rated capacity being used. Yellow indicates 90–99.9%, and the red lights indicate an overload.

Note: System may be equipped with an overhead bar-graph or an external light bar which operates similar to the bar-graph on the display. Refer to Figure 1–73.

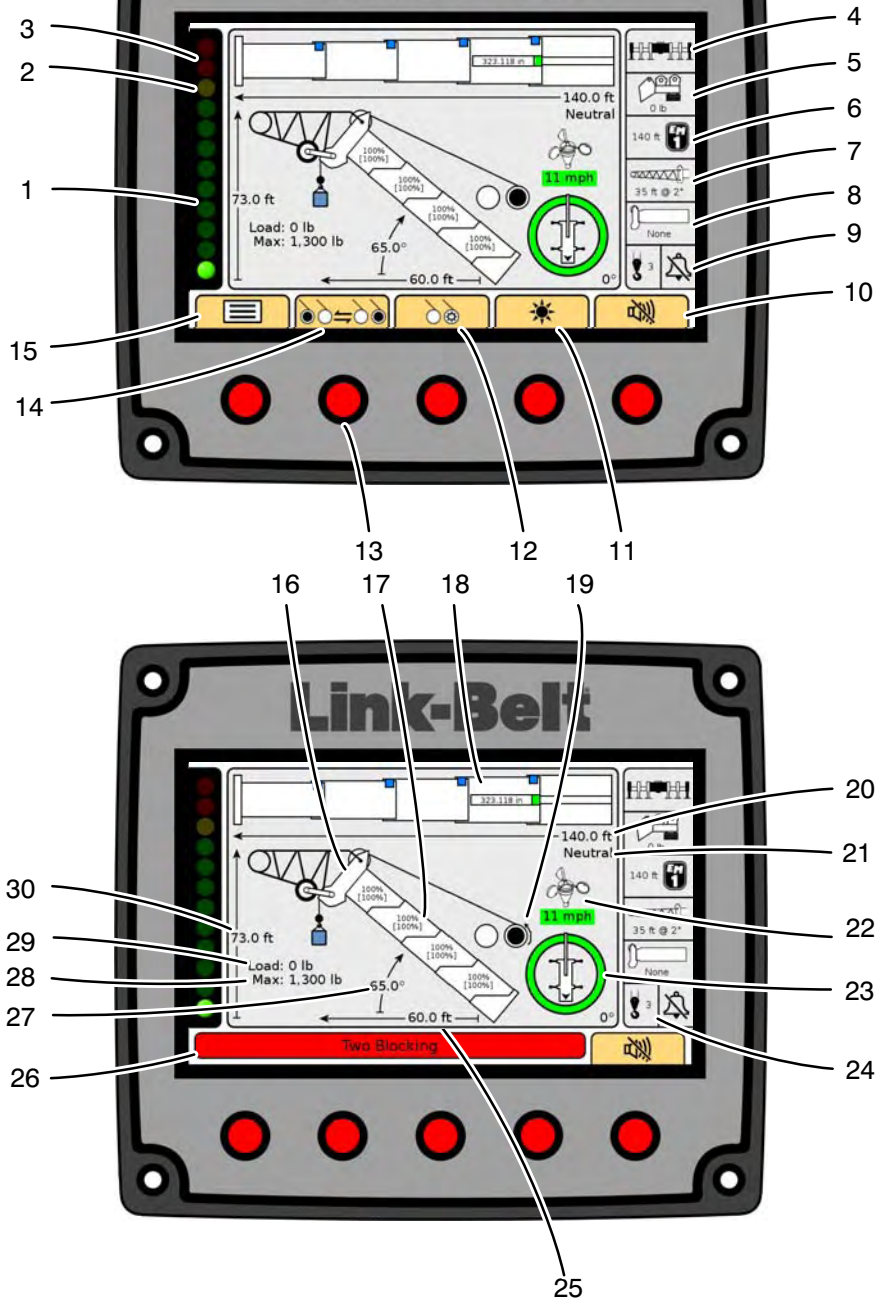

- | | | |
|------------------------------------|--|------------------------------------|
| 1. Bar-Graph | 11. Brightness Icon | 21. Boom Controller Message |
| 2. Pre-Alarm Indicator | 12. Winch Setup Icon | 22. Wind Speed Display |
| 3. Overload Indicator | 13. Selection Buttons | 23. Working Area Display |
| 4. Outrigger Configuration | 14. Winch Select Icon | 24. Parts of Line Display |
| 5. Counterweight Configuration | 15. Main Menu Icon | 25. Load Radius Display |
| 6. Boom Extension Mode | 16. Crane Representation Image | 26. Warning Message Area |
| 7. Attachment Configuration | 17. Boom Section Length Display | 27. Boom Angle Display |
| 8. Stowed Attachment Configuration | 18. Boom Telescope Animation Display | 28. Maximum Rated Capacity Display |
| 9. Operator Alarm Indicator | 19. Drum Rotation Direction Indicator (DRDI) | 29. Actual Load Display |
| 10. Cancel Alarm Icon | 20. Boom Length Display | 30. Boom Head Height Display |

Figure 1–74
Rated Capacity Limiter

Operator's Manual

2. Pre-Alarm Indicator

The Pre-Alarm Indicator illuminates yellow at a pre-set value of 90% of Maximum Rated Capacity and provides a visual indication of an approach to an overload.

3. Overload Indicator

The Overload Indicator illuminates red at a pre-set value of 100% of the Maximum Rated Capacity and provides a visual indication of Maximum Allowed Load. It will also illuminate whenever a wire rope limit is exceeded. Function limiters will occur simultaneously for an Overload, Wire Rope Limit, or a Two-Block condition, but function limiters will not occur when exceeding an operator settable alarm. An audible alarm will sound and a message will appear in the warning message area for all 4 conditions.

4. Outrigger Configuration

This area displays the current outrigger configuration. It will also display rigging and travel modes.

5. Counterweight Configuration

This area displays the current counterweight configuration.

6. Boom Extension Mode

This area displays the current boom extension mode. It also shows the maximum boom length for the current boom extension mode.

7. Attachment Configuration

This area displays the current attachment configuration.

8. Stowed Attachment Configuration

This area displays the current stowed attachment configuration.

9. Operator Alarm Indicator

This indicator will display whether or not an operator alarm is set.

10. Cancel Alarm Icon

The button below this icon can be pushed once to silence the audible alarm when the alarm has occurred as a result of either an Overload, a Two Block, or an Operator Settable alarm. It is also used to reset the function limit relay when it is necessary to bypass a function limit which has occurred as a result of either an Overload or a Two Block alarm. This requires the button be pressed and held for 2 seconds or longer.

11. Brightness Icon

The button below this icon is used to adjust the display brightness.

12. Winch Setup Icon

The button below this icon is used to enter the active winch setup screen. The active winch setup screen allows the user to configure lift point and parts of line for the active winch.

13. Selection Buttons

The selection buttons are used to activate each of the icons at the bottom of the screen. The icons will change depending on the current menu display.

14. Winch Select Icon

The button below this icon is used to select which winch will be in use.

15. Main Menu Icon

The button below this icon navigates to the main menu. The main menu contains items such as: Crane Configuration, Operator Alarms, Diagnostics, Setup, About.

16. Crane Representation Image

This crane representation image is a generic representation of the boom, active winch configuration, auxiliary head configuration (on or off), and fly configuration (on or off). The attachment image will not change with installed attachment.



17. Boom Section Length Display

The Boom Section Length Display shows the current section lengths as a percentage of their absolute maximum length (not in the current boom mode). The maximum length for each section in the current boom mode is shown in brackets.

18. Boom Telescope Animation Display

The Boom Telescope Animation Display is a real-time visual representation of the location of the boom sections, location of the telescope cylinder, and the status of the pins and latches. It also includes a numeric readout of the telescope cylinder length in inches (*cm*).

19. Drum Rotation Direction Indicator (If Equipped)

This Drum Rotation Direction indicator (DRDI) is used to monitor Winch Up , Winch Down , and Error states .

Note: If the error state indicator appears, contact your Link-Belt Distributor or factory for service.

Operator's Manual

20. Boom Length Display

The Boom Length Display gives a continuous indication of the boom length in feet (*m*). It is the distance from the centerline of the boom foot pin to the centerline of the boom head machinery.

21. Boom Controller Message

The Boom Controller Message displays the most recent message sent from the boom controller. This message may contain operation messages or error messages.

22. Wind Speed Display

The current wind speed is displayed here.

23. Working Area Display

This area displays a graphical representation of the allowable lifting quadrant(s) based on the selected configuration. A quadrant not allowed will be filled red, an allowable quadrant will be filled green.

24. Parts of Line Display

The Parts of Line Display shows the parts of line currently selected for the winch in use.

25. Load Radius Display

The Load Radius Display gives a continuous indication of the radius of the load in feet. It is the horizontal distance from the centerline of rotation to the centerline of the hook.

26. Warning Message Area

The Warning Message Area displays text messages of various alarms which may occur during normal operation of the system. When an alarm occurs, the rectangular area fills in red. The Warning Message Area will only be shown when there is an active message. Otherwise the navigation button icons will be shown. Refer to Figure 1–76. Press any of the selection buttons, except the cancel alarm button, to temporarily replace the Warning Message Area with the navigation icons.

27. Boom Angle Display

The Boom Angle Display gives a continuous indication of the angle of the main boom relative to horizontal.

28. Maximum Rated Capacity Display

The Maximum Rated Capacity Display is a digital display of the maximum permitted capacity. It is derived from a copy of the crane's capacity chart which is stored in the computer memory and is the reference capacity for any lifting operation. It is dependent on the configuration currently selected, which is shown in the crane configuration screen, and which determines the section of the capacity chart to be used as the rated capacity reference.

29. Actual Load Display

The Actual Load Display is a digital display of the total load suspended below the boom or fly head. It includes the load, any slings, pins, or tackle used to secure the load and the hook block or ball.

30. Boom Head Height Display

The Boom Head Height Display gives a continuous display of the height of the boom head or attachment head above the carrier deck.

Operator's Manual

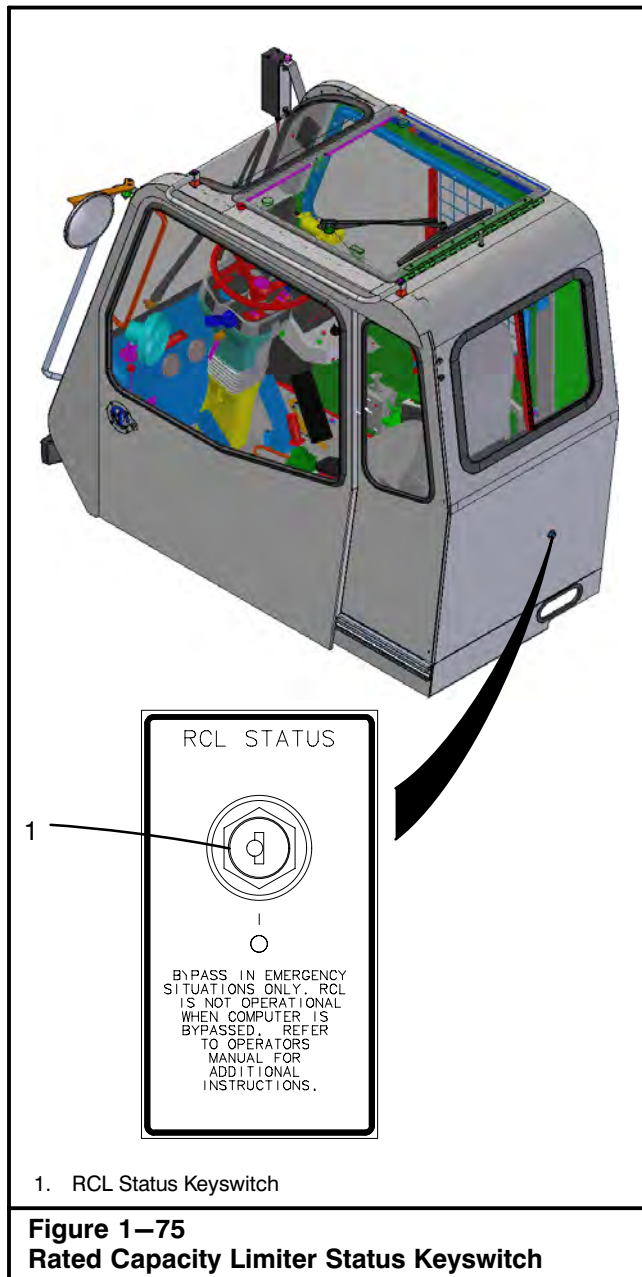

System Operation

The following is a list of procedures which are used to operate the multiple features of the Rated Capacity Limiter. Use these procedures in conjunction with the previous display unit control descriptions.

System Bypass

In emergency situations, the Rated Capacity Limiter computer can be bypassed. There is a RCL Status keyswitch on the back of the operator's cab, to bypass the system. Refer to Figure 1–75. Move the ignition

switch to the "RCL BYPASSED" position to bypass the system. For emergency use while the system is bypassed, refer to "System Inoperative or Malfunctioning" in this Section of this Operator's Manual.



WARNING

The RCL System is not operational when the computer is bypassed. Bypass the system in emergency situations only.

System Inoperative Or Malfunctioning

When operational aids are inoperative or malfunctioning, the following recommendations for continued use of the crane should be followed or the crane should be shutdown.

1. Steps shall be taken to schedule repairs and recalibration immediately. The operational aids shall be put back into service as soon as replacement parts, if required, are available and the repairs and recalibration can be carried out. Every reasonable effort must be made to expedite the repairs and recalibration.
2. When the Rated Capacity Limiter is inoperative or malfunctioning, the designated person responsible for supervising the lifting operations shall establish procedures for determining load weights and shall ascertain that the weight of the load does not exceed the crane ratings at the radius where the load is to be handled.
3. When a boom angle or radius indicator is inoperative or malfunctioning, the radius or boom angle shall be determined by measurement.
4. When the anti-two block warning device is inoperative or malfunctioning, the designated person responsible for supervising the lifting operations shall establish procedures, such as assigning an additional signal person, to furnish equivalent protection. This does not apply when lifting personnel in load line supported baskets. Personnel shall not be lifted in load line supported baskets when the anti-two block devices are not functioning properly.
5. When a boom length indicator is inoperative or malfunctioning, the designated person responsible for supervising the lifting operations shall establish the boom length at which the lift will be made by actual measurement or markings on the boom.
6. When a level indicator is inoperative or malfunctioning, other means shall be used to level the crane.
7. In situations where inconsistency exists, verified weights, measured radii, boom lengths, and authorized crane capacities must always take precedence over indicator readings.

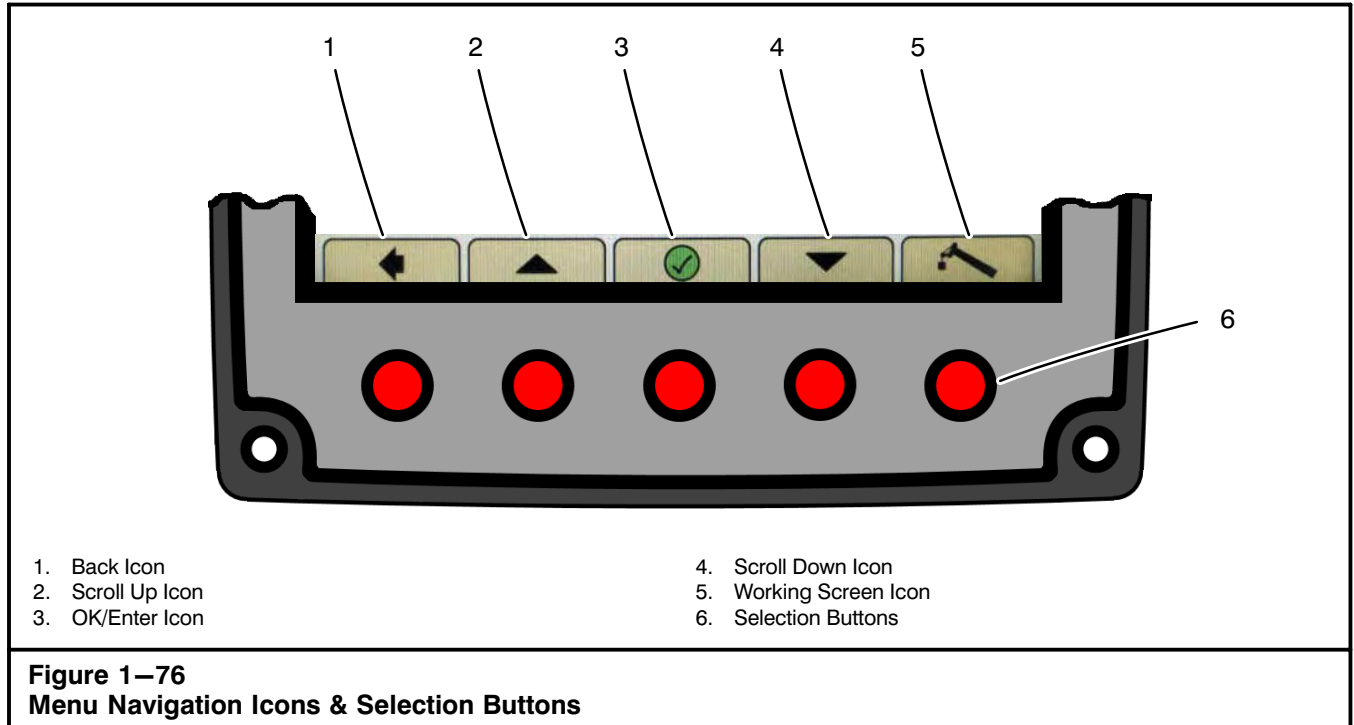

System Navigation

The RCL Display has two main display modes; the working screen and the menu. The working screen displays all information relevant to the safe operation of the crane. This includes crane configuration as well as live data such as boom length and load radius. The menu is used to navigate to various setup and diagnostic screens needed to properly setup the system. Although the five navigation icons at the bottom of the screen will change depending on what the display is currently showing, the five primary icons for menu navigation are as follows. Refer to Figure 1–76. If a task associated with a button is not available, that button will be disabled and greyed out.

1. Back Icon

The selection button below the Back Icon navigates back one menu.

2. Scroll Up Icon

The selection button below the Scroll Up Icon scrolls up one menu item each time it is pressed.

3. OK/Enter Icon

The selection button below the OK/Enter Icon selects the menu item currently highlighted.

4. Scroll Down Icon

The selection button below the Scroll Down Icon scrolls down one menu item each time it is pressed.

5. Working Screen Icon

The selection button below the Working Screen Icon immediately navigates to the working screen when it is pressed.

6. Selection Buttons

These buttons are used to select the function of the icon displayed above them.

Operator's Manual

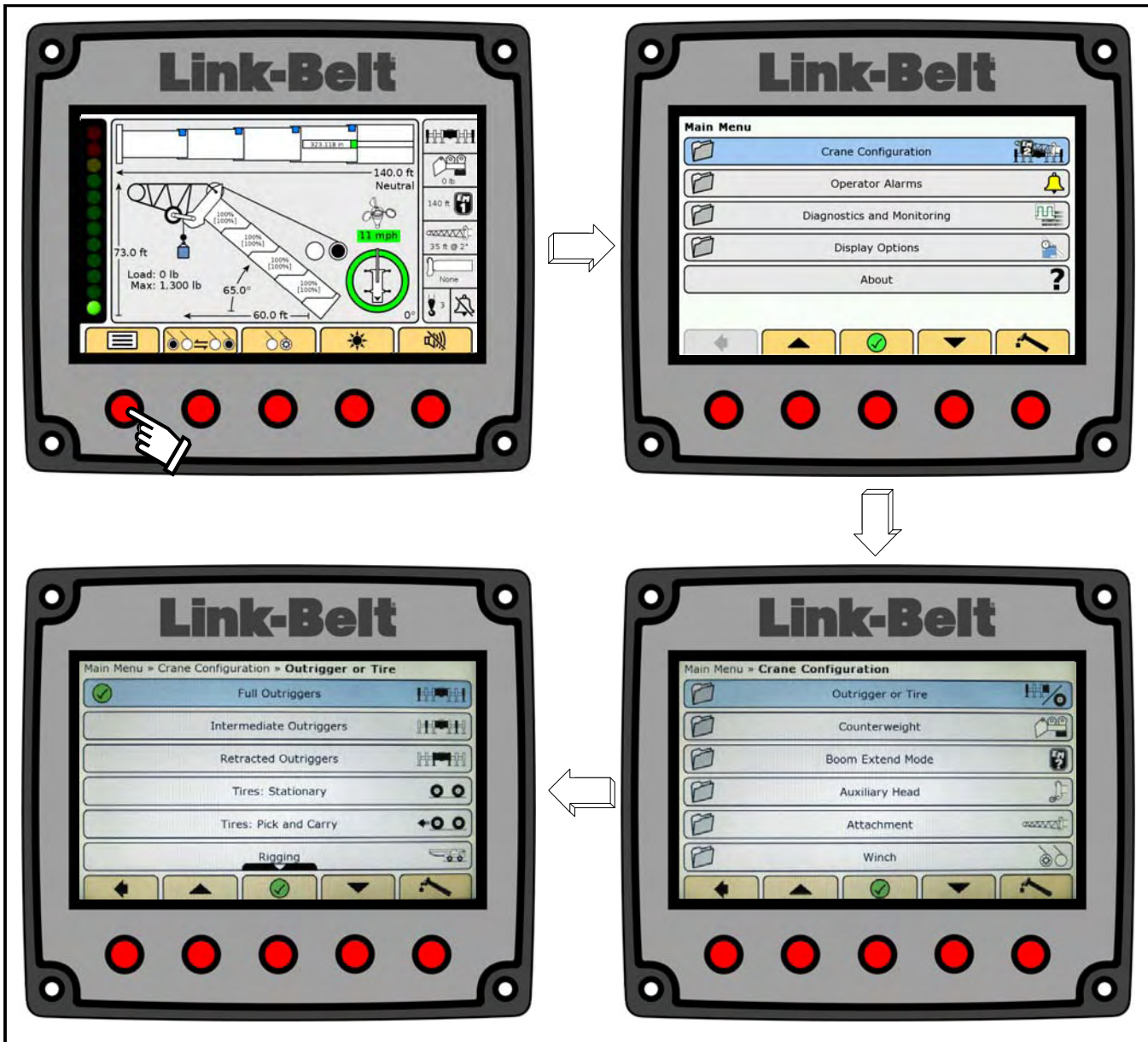





Figure 1-77
Carrier Selection

Configuration Selection

In the normal operational mode the system is programmed to remember the last configuration selected. Each time the system is powered up it will automatically default to that last configuration. Only when the crane is rigged differently must a new configuration be selected. Use the following procedure to select the crane configuration.

Note: When selecting configurations allowed on outriggers, all beams must be equally extended; all fully retracted, intermediate extended, or fully extended.

Depending on how the crane is equipped or which selections have been made, some screens shown may not appear or may not appear as illustrated. The system cannot be programmed for configurations not allowed by the capacity charts in the Crane Rating Manual.

1. From the normal working screen, press the Main Menu button .
2. Scroll to Crane Configuration, and press the OK/Enter button .
3. Scroll to Outrigger or Tire, and press the OK/Enter button . Refer to Figure 1-77.

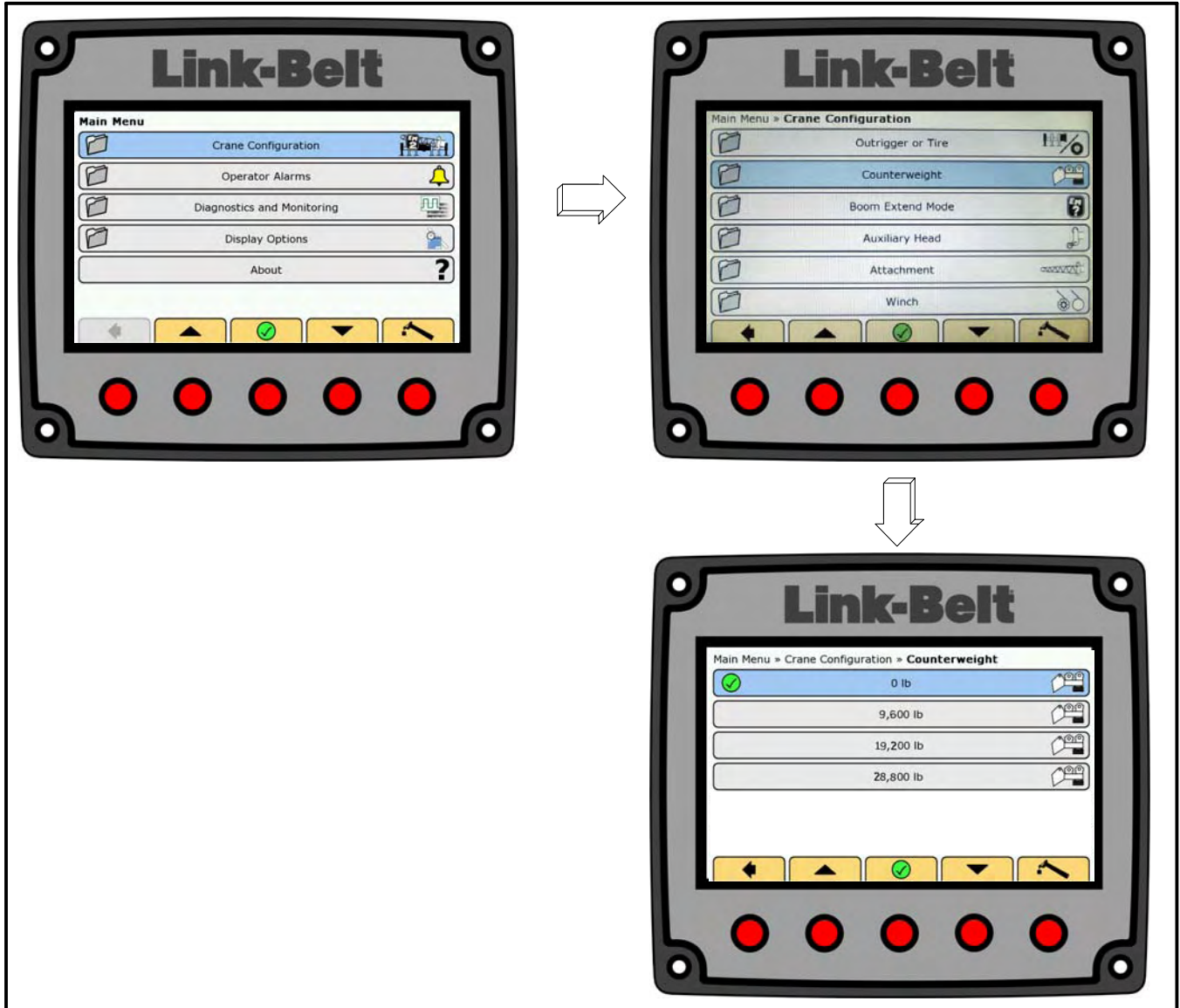

Figure 1–78
Counterweight Selection

4. The menu will change and graphically display the carrier options. Scroll to the desired carrier configuration, and press the OK/Enter button . If rigging is desired, refer to “To Select Rigging And Travel Modes” in this Section of this Operator’s Manual.



WARNING

The RCL System is not operational when in the Rigging or Travel Modes. Return the RCL System to normal operation before operating the crane.

Note: If an “Outrigger Position Mismatch” warning appears on the display, ensure the outriggers are in the correct position and select the configuration on the display to match the current outrigger position.

5. After a selection is made, the display will automatically return to the Crane Configuration menu.
6. On the Crane Configuration menu, scroll to Counterweight, and press the OK/Enter button .
7. Scroll to the desired counterweight, and press the OK/Enter button . Refer to Figure 1–78.
8. After a selection is made, the display will automatically return to the Crane Configuration menu.

Operator's Manual

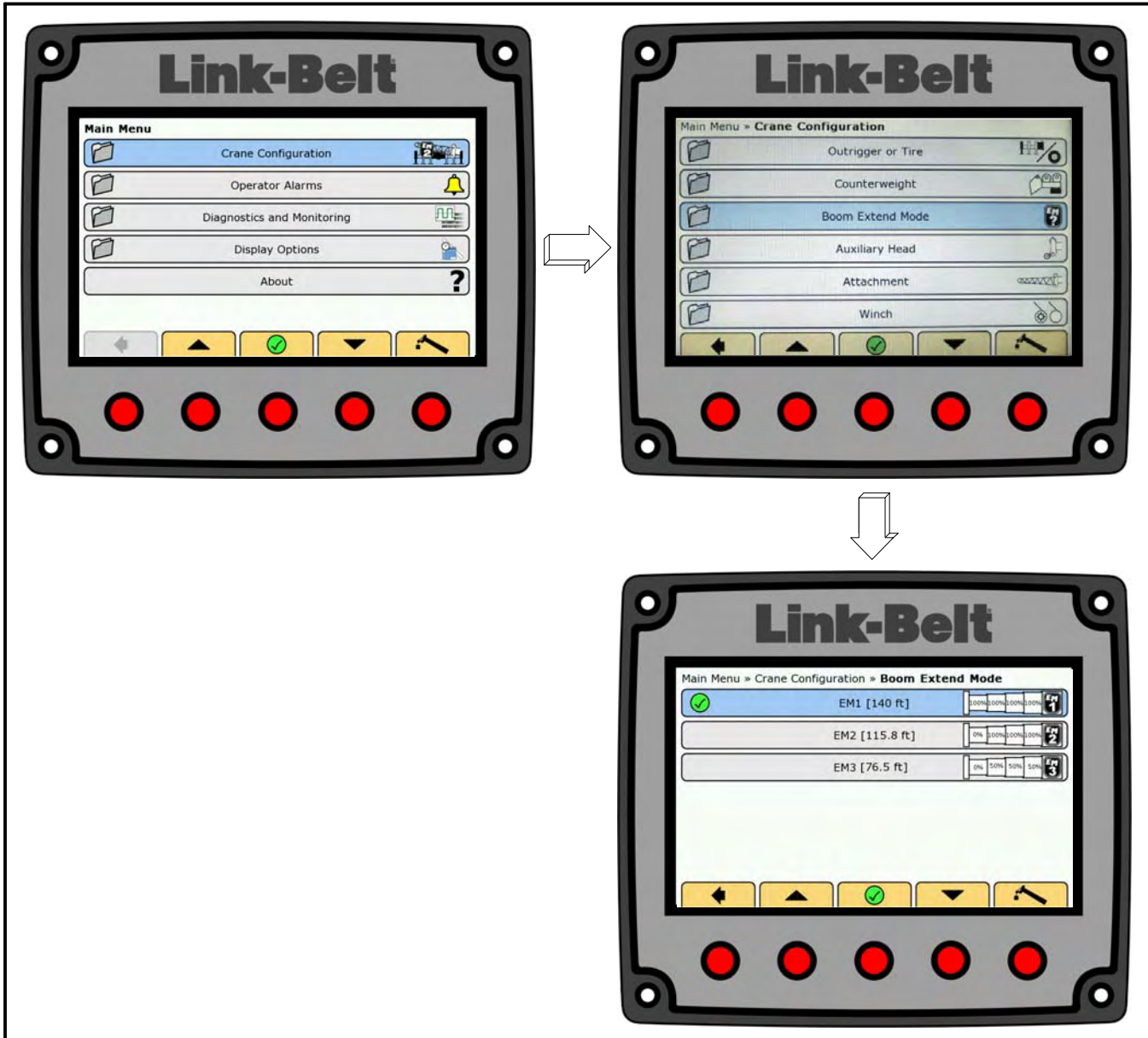

Figure 1–79
Boom Extend Mode Selection

9. On the Crane Configuration menu, scroll to Boom Extend Mode, and press the OK/Enter button . Refer to Figure 1–79.
10. Scroll to the desired boom extend mode, and press the OK/Enter button .

Note: Refer to the Crane Rating Manual to determine the best boom mode to maximize lifting capacity at working radius. Boom mode options will only be displayed when the boom is fully retracted and the telescope cylinder unlatched from all boom sections.

11. After a selection is made, the display will automatically return to the Crane Configuration menu.

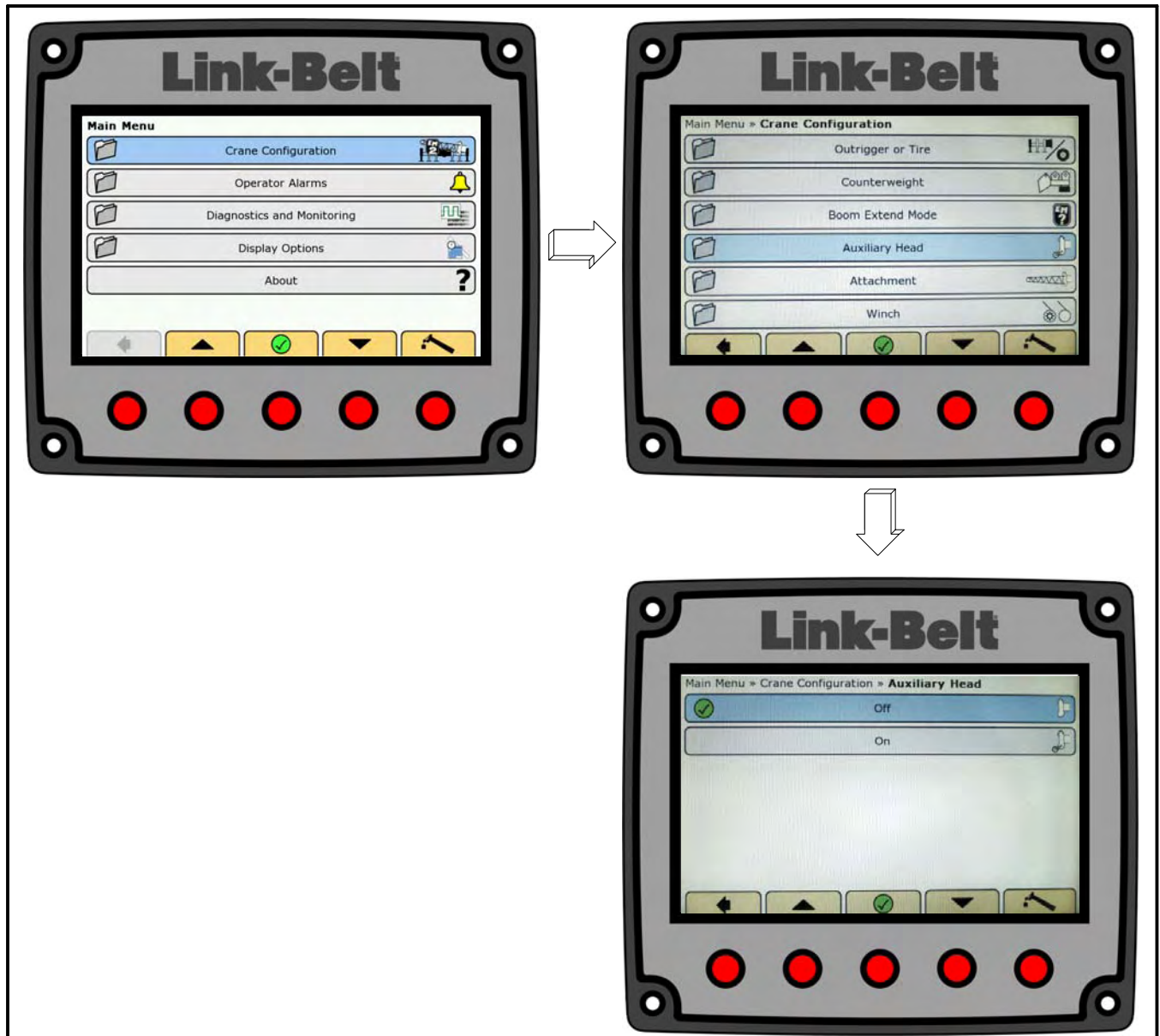

Figure 1–80
Auxiliary Head Selection

12. On the Crane Configuration menu, scroll to Auxiliary Head, and press the OK/Enter button . Refer to Figure 1–80.
 13. Scroll to the desired auxiliary head (off or on), and press the OK/Enter button .
 14. After a selection is made, the display will automatically return to the Crane Configuration menu.
 15. On the Crane Configuration menu, scroll to Attachment, and press the OK/Enter button .
 16. Scroll to Erected Attachment, and press the OK/Enter button to display the fly options. Scroll to the desired erected fly, if required, and press the OK/Enter button . Refer to Figure 1–81.
- a. If Nothing Erected is selected, the display will automatically return to the Crane Configuration menu.
 - b. If an erected attachment is selected, the display will change and graphically display the available offsets as required.
 - c. Scroll to the desired offset angle, and press the OK/Enter button . Refer to Figure 1–81.
 - d. After a selection is made, the display will automatically return to the Crane Configuration menu.

Operator's Manual

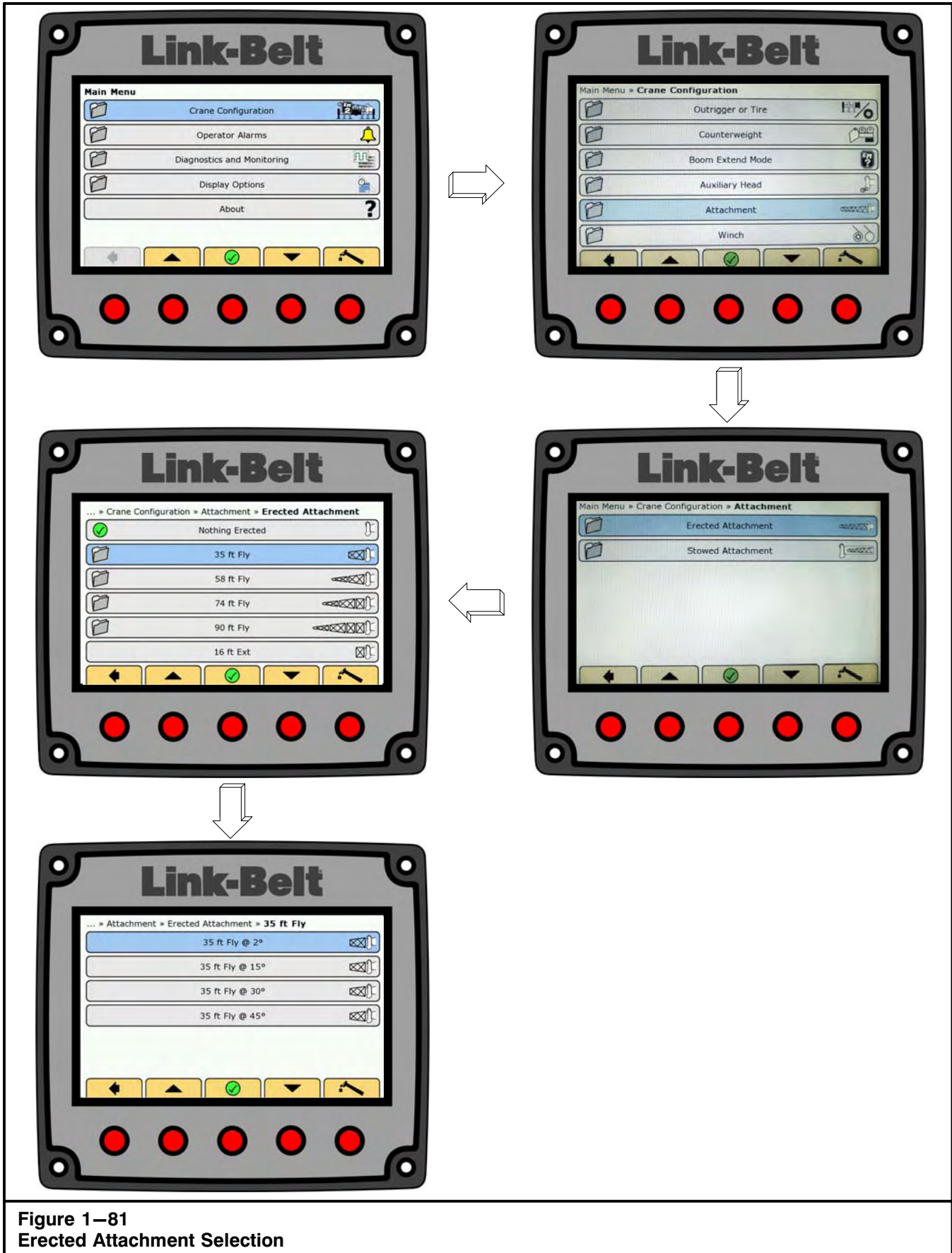

Figure 1–81
Erected Attachment Selection

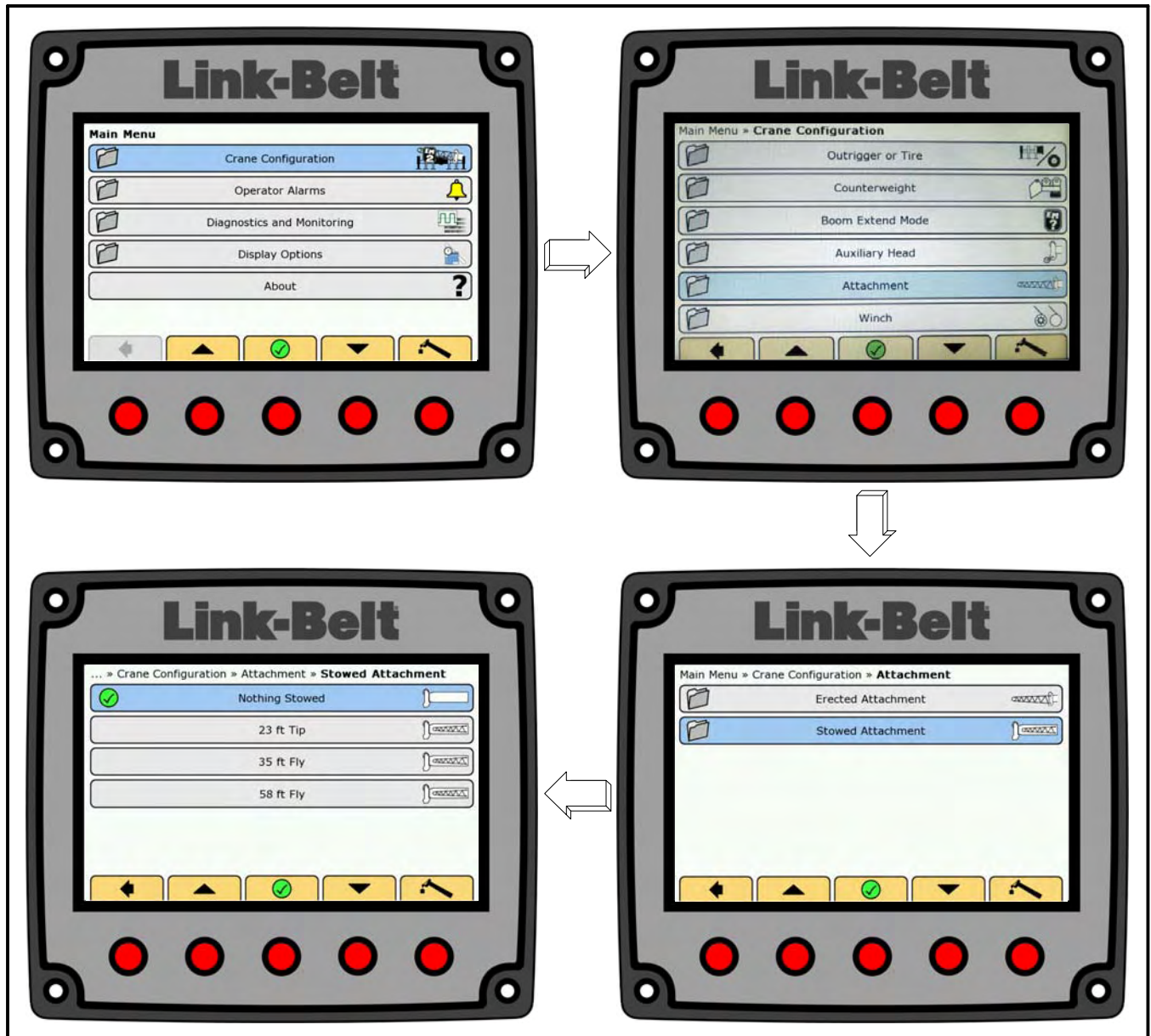



Figure 1–82
Stowed Attachment Selection

17. If the crane is equipped with a fly and was not selected as an erected attachment, on the Crane Configuration menu, navigate to Attachment » Stowed Attachment to display the stowed fly options. Scroll to the desired stowed deduct, if re-

quired, and press the OK/Enter button . Refer to Figure 1–82.

18. After a selection is made, the display will automatically return to the Crane Configuration menu.

Operator's Manual

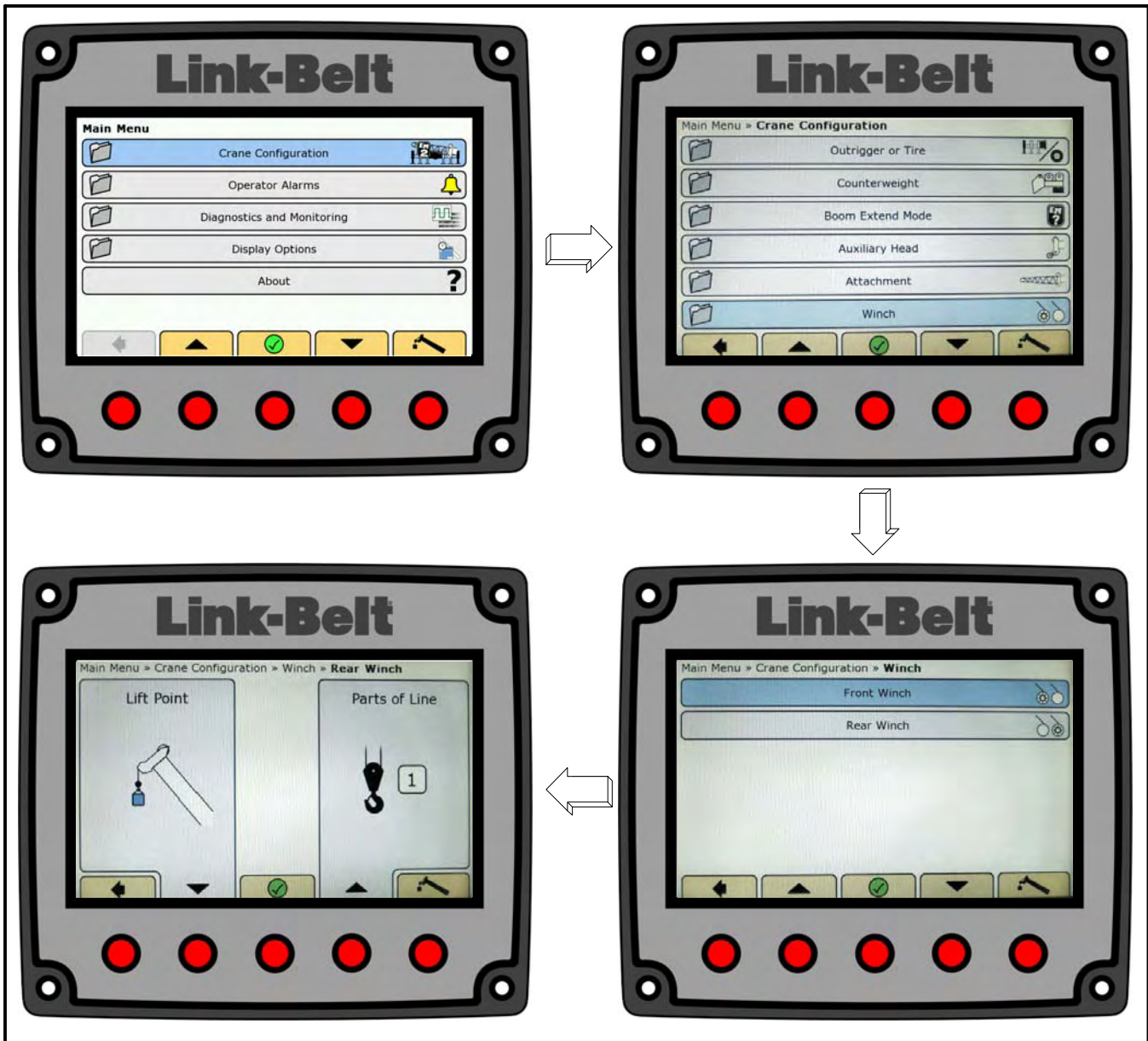



Figure 1-83
Winch Configuration

19. On the Crane Configuration menu, scroll to Winch, and press the OK/Enter button  to display the front and rear winch items. Refer to Figure 1-83.
 - a. Scroll to the desired winch menu item, and press the OK/Enter button . This will only

configure the selected winch. The winch select button on the working screen is used to change the active winch.

Operator's Manual

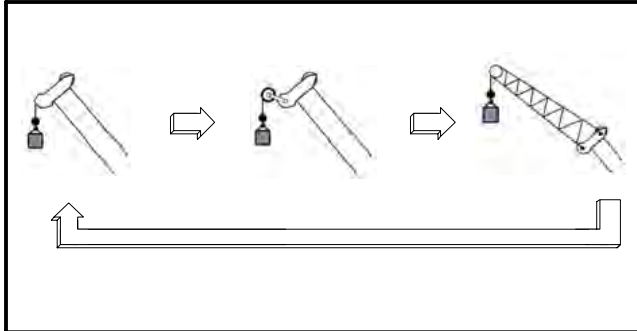





Figure 1–84
Lifting Point Selection

- b. Scroll through the available lifting points until the desired lifting point, for the winch selected, is displayed. Refer to Figure 1–84.
- c. Scroll through the available parts of line until the desired parts of line, for the winch selected, is displayed. Refer to Figure 1–85.
- d. Press the OK/Enter button  to confirm the selections for lifting point and parts of line. If the back button  or working screen button  is pressed before pressing the OK/Enter button , the changes made to lifting point and parts of line will not be saved.
- e. Repeat Steps a thru d for the other winch, if required.

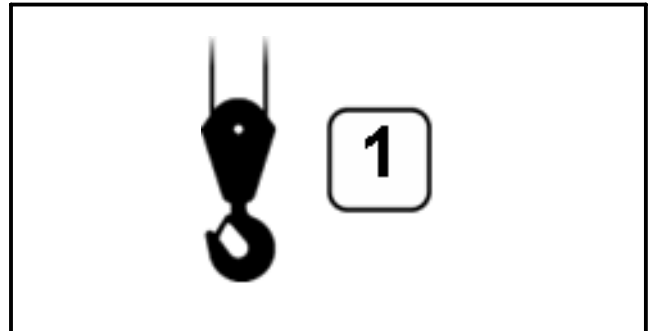



Figure 1–85
Parts Of Line Selection

20. Press the back button  to navigate back to the Crane Configuration menu.

Note: A change to any selection can be made at anytime during the configuration routine. When on the Crane Configuration menu, simply navigate to the desired configuration menu to go directly to that sub-routine.

21. Press the Working Screen button  to return to the normal working screen and graphically display the crane configuration as previously selected.

Operator's Manual

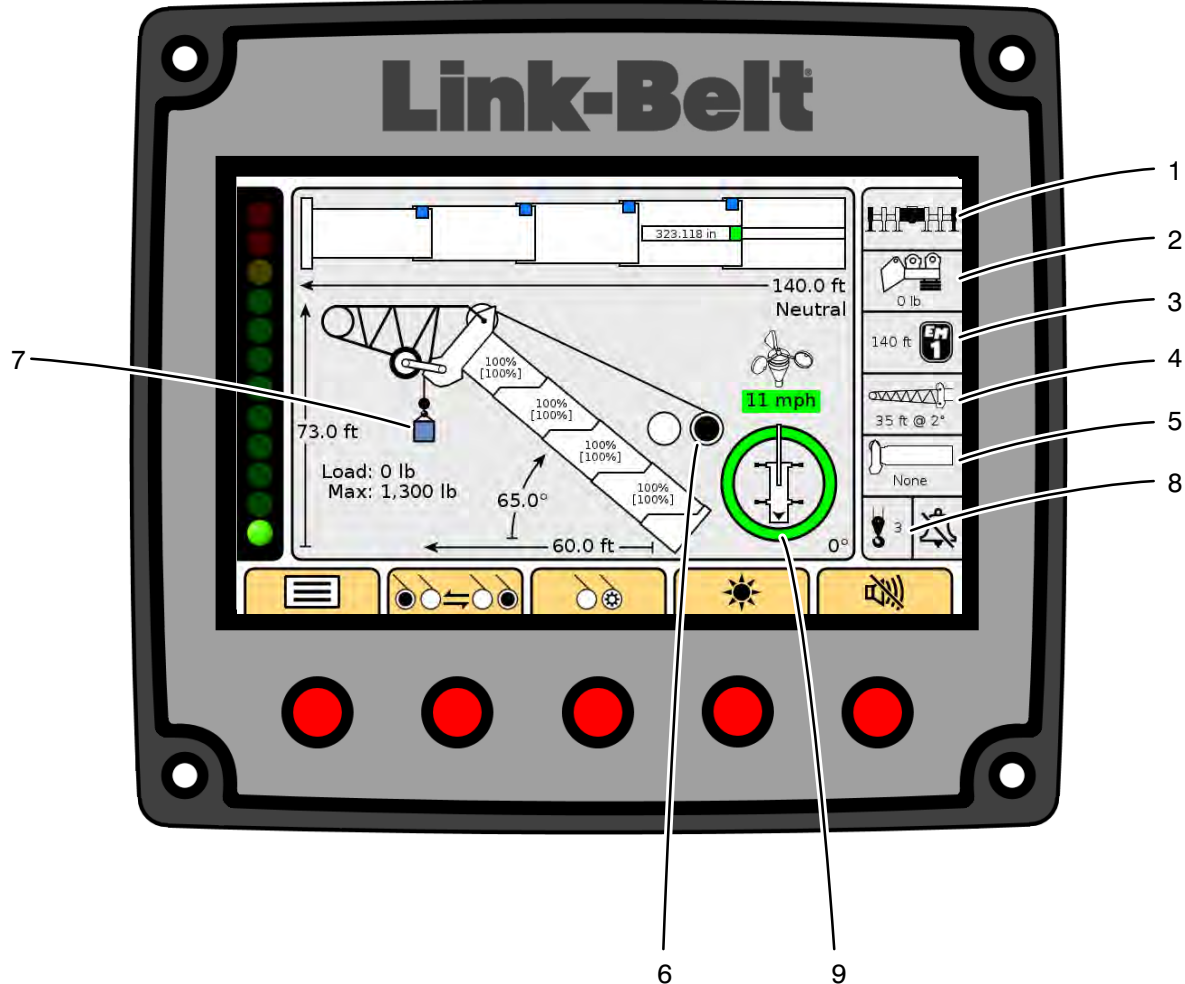

In this example the crane is setup on fully extended outriggers (1), 0 lb of counterweight (2), boom mode EM1 (3), 35 ft fly erected at 2 degree offset (4), no stowed attachment (5), the front winch available with the fly and the rear winch selected (6), with the winch wire rope reeved over the main boom head (7), with three parts of line (8), and 360 degree capacities with the boom currently positioned over the rear (9).

Figure 1–86
Normal Working Screen Example

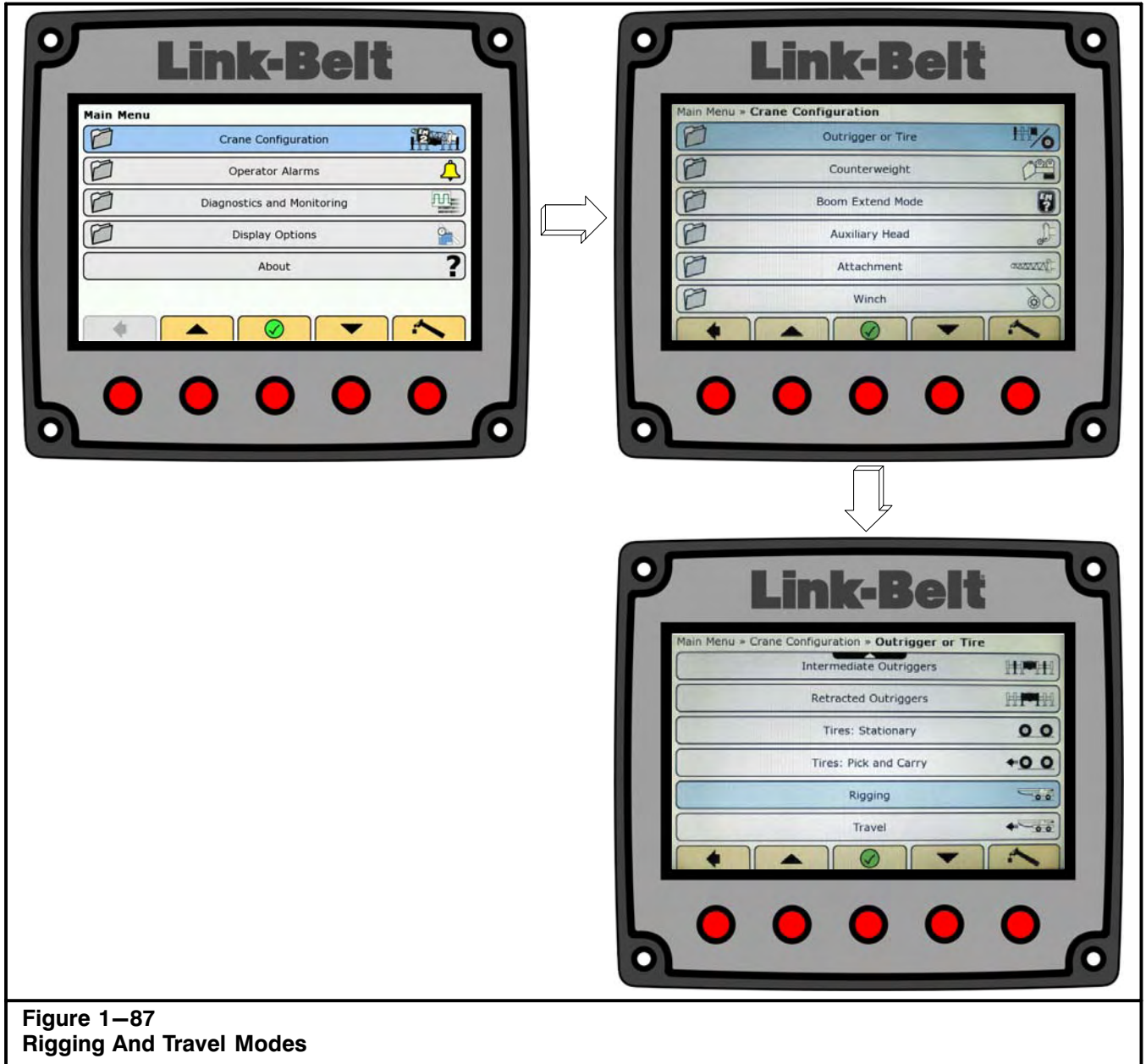

Figure 1–87
Rigging And Travel Modes

Operator's Manual



To Select Rigging And Travel Modes

The Rigging and Travel modes are used to facilitate rigging and travel of the crane by inhibiting function limiters and the audible alarm while selected. Refer to Figure Figure 1–87. To resume crane operation, select proper outrigger or tire configuration per the proper procedure.



WARNING

The RCL System is not operational when in the Rigging or Travel modes. Return the RCL System to normal operation before operating the crane.

1. From the normal working screen, press the Main Menu button .
2. Navigate to Crane Configuration » Outrigger or Tire.
3. Scroll to Rigging or Travel.
4. Select Rigging  for rigging of the crane. Select Travel  when traveling the crane.

Note: Boom must be fully retracted to enter Travel Mode.

When changing from Travel Mode to Rigging Mode, an outrigger selection and boom mode selection must be made prior to selecting Rigging mode.

Cancel Audible Alarm And Reset Function Limiters

The CANCEL ALARM button  is used to cancel the audible alarm when the alarm has occurred as a result of either an Overload, a Two Block alarm, or an Operator settable alarm. The audible alarm may be canceled

by pressing and releasing the CANCEL ALARM button. The audible alarm remains canceled until the condition which caused the alarm has been removed. For example, if the audible alarm was canceled because of an overload condition, it will remain canceled until the overload condition is removed. However, if a different alarm, e.g. two block condition, was to occur when the audible alarm was still canceled for an earlier overload condition, the new alarm condition would cause the audible alarm to be sound.



WARNING

Once the function limiters have been bypassed, the crane is no longer protected against the condition that initially caused the function limiters to occur.

Note: The CANCEL ALARM feature is a temporary function. The audible alarm or function limit is automatically reset when the condition which caused the alarm is no longer present.

The CANCEL ALARM is also used to reset the function limiters when it is necessary to bypass the function limiters which has occurred as a result of either an Overload, a Two Block alarm, or a Wire Rope limit. Function limiters are reset by first canceling the audible alarm (as described above) and then pressing and holding the CANCEL ALARM button for about 2 seconds, after which the function limiters will be reset to allow operation. However, should another different alarm condition occur when the function limiters had previously been over-ridden, then the newly occurring alarm condition would cause the function limiters to occur again.

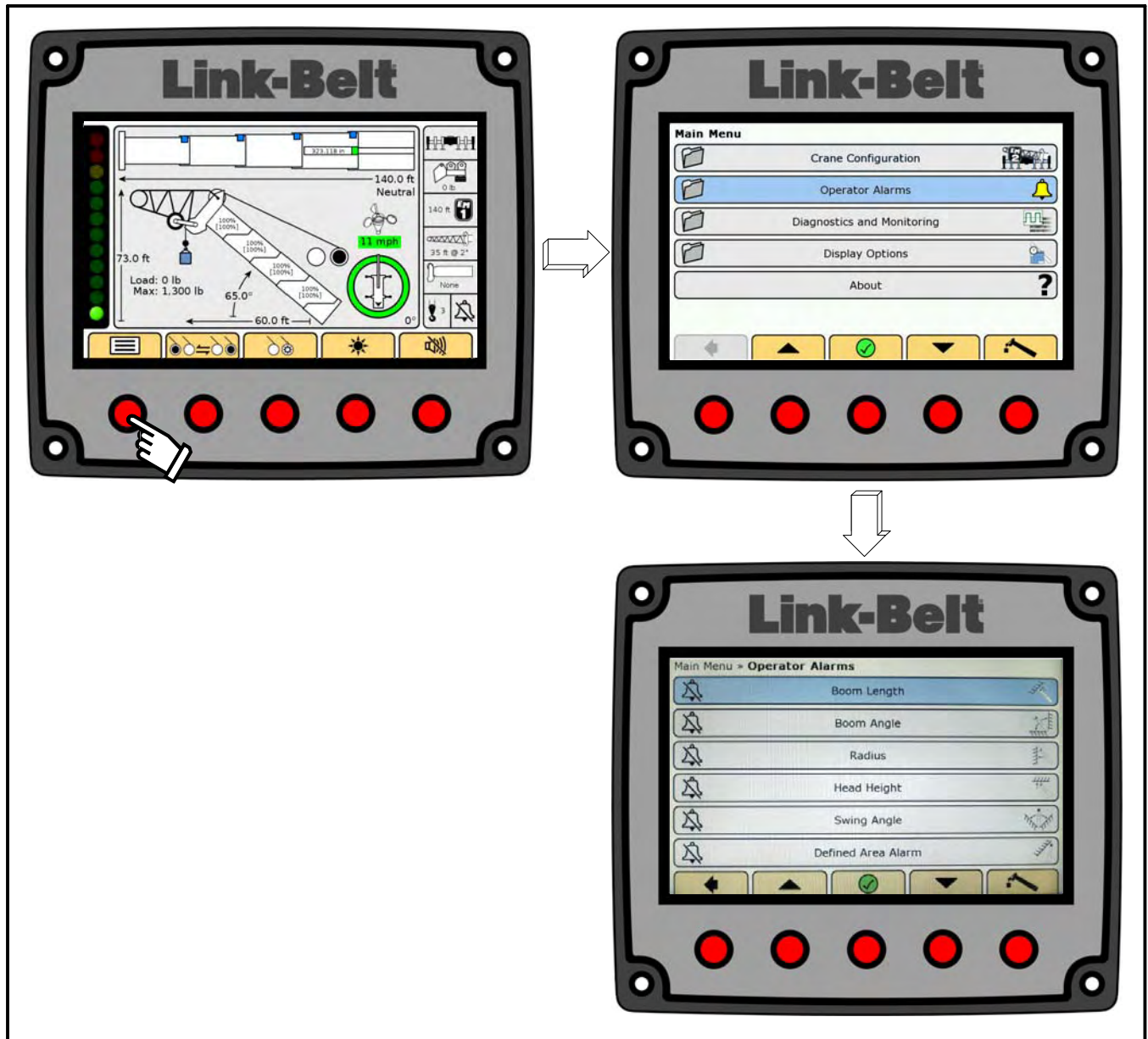

Figure 1-88
Operator Settable Alarms

Operator Settable Alarms

Some alarms occur automatically as a result of limitations imposed by the capacity chart. The operator has control over additional alarms which can be set to operate within the normal chart limitations and which are, in addition to those already set by the chart.

Operator alarms will be stored in the computer memory, even if the crane is shutdown, until they are disabled. Refer to Figure 1-88.

The following alarms are available for operator use.

| | | |
|----------------|-----------------------|----------------------|
| Minimum Angle | Maximum Load Radius | Left and Right Swing |
| Maximum Angle | Maximum Boom Length | |
| Maximum Height | Operator Defined Area | |

WARNING

The operator settable alarms are a warning device. All functions remain operational when entering the operator defined bad area. For safe operation, adequate distance must be maintained to allow for operator reaction time to avoid entering the bad area. It is the responsibility of the operator to set points which ensure that the crane's boom, attachment, load, rigging, etc. maintains a safe working distance and complies with local safety regulations.

Operator's Manual

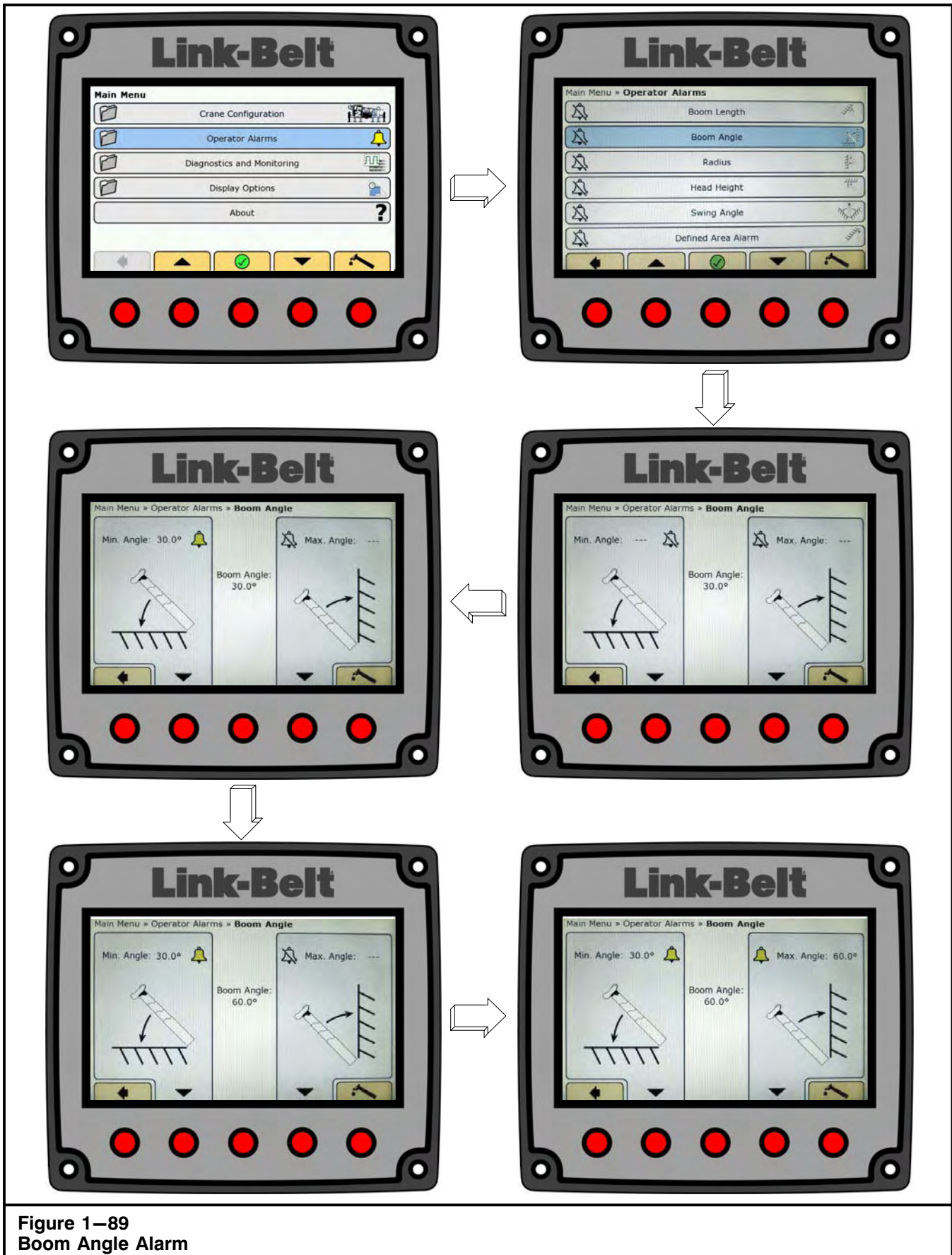





Figure 1-89
Boom Angle Alarm

Operator's Manual

Setting Angle, Length, Height, Radius, And Swing Operator Settable Alarms



1. From the normal working screen, press the Main Menu button .
2. Scroll to Operator Alarms, and press the OK/Enter button . Refer to Figure 1–88.
3. Scroll to the desired alarm to be set, and press the OK/Enter button .



WARNING



Avoid positioning the boom, attachment, load, rigging, etc. into the bad area when setting the alarm values.

When selecting the alarm values, ensure that the load will maintain a safe distance from the obstacle.

4. Place the crane in the desired position depending upon the alarm to be set. The numerical value for the value being set will be the current position of the crane.

Note: If an alarm had been previously set, the alarm value displayed will be the previously set alarm value and indicated by the  icon. The previous alarm must first be disabled, then set the new alarm. Alarms which are disabled are indicated by the .

5. Press the corresponding selection button to set the alarm value.
6. Press the back button  to return to the Operator Alarms menu or press the Working Screen button  again to return to the normal working screen.
7. Test the alarm, with no load, to ensure the alarm points have been properly set. When approaching the alarm set point, the audible alarm will sound intermittently and a warning message will appear in the warning message area. When exceeding the alarm set point, the audible alarm will sound continuously and a warning message will appear in the warning message area.

Note: An alarm icon  will appear on the normal working screen to alert the operator that an operator alarm has been set. If no operator alarm is set, the alarm disabled icon  will appear.

8. Use the following examples to understand the use of the procedure.

WARNING







If crane or obstacle is moved or if a different size load is lifted, the alarm(s) must be reset.

WARNING

Check the crane's current configuration, capacity chart, and Working Areas chart in the Crane Rating Manual to ensure safe, stable operation under conditions described in the following examples.

To Set Minimum Angle Alarm

Example: To have an alarm whenever the boom is below a 30 degree angle, use the following procedure:

1. From the normal working screen, press the Main Menu button .
2. Scroll to Operator Alarms, and press the OK/Enter button . Refer to Figure 1–89.
3. Scroll to Boom Angle , and press the OK/Enter button .
4. Move the boom to a 30 degree angle.
5. Press the corresponding button for "Min. Angle" to set the alarm. The displayed value will be the alarm setting. The  will appear to indicate that the alarm is set.
6. Press the back button  to return to the Operator Alarm menu or press the Working Screen button  again to return to the normal working screen.
7. Test the alarm, with no load, to ensure the alarm points have been properly set. When approaching 30 degree boom angle, the audio will sound intermittently and "Approaching Minimum Angle" will appear in the warning message area. The audible alarm will sound continuously and "Minimum Angle" will appear in warning message area whenever the boom is lowered below 30 degrees.

Operator's Manual

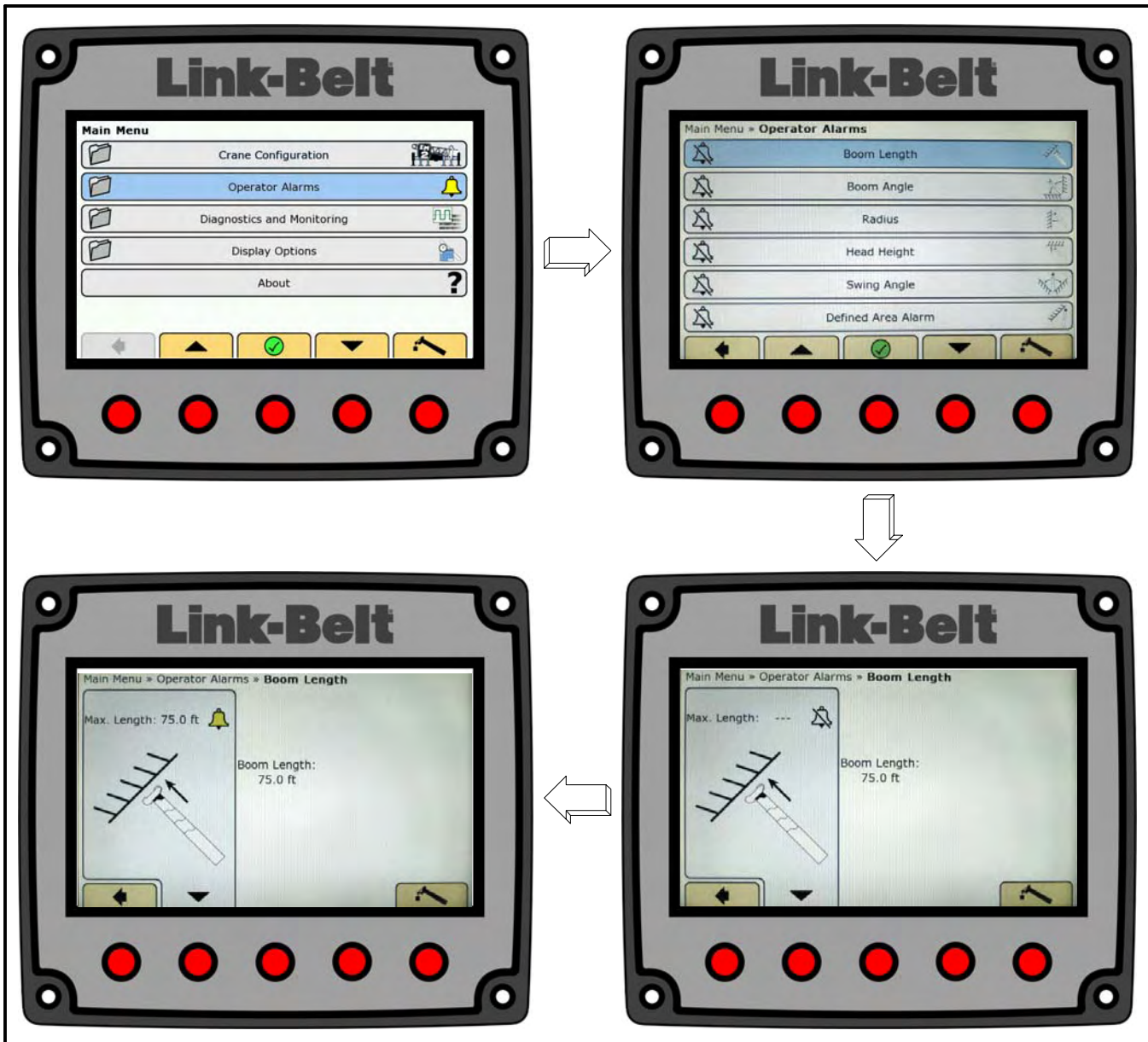









Figure 1-90
Boom Length Alarm

To Set Maximum Angle Alarm

Example: To have an alarm whenever the boom is above a 60 degree angle use the following procedure:





1. From the normal working screen, press the Main Menu button .
2. Scroll to Operator Alarms, and press the OK/Enter button .
3. Scroll to Boom Angle , and press the OK/Enter button .
4. Move the boom to a 60 degree angle.
5. Press the corresponding button for "Max. Angle" to set the alarm. The displayed value will be the alarm setting. The  will appear to indicate that the alarm is set.
6. Press the back button  to return to the Operator Alarms menu or press the Working Screen button  again to return to the normal working screen.



Operator's Manual

7. Test the alarm, with no load, to ensure the alarm points have been properly set. When approaching 60 degree boom angle, the audio will sound intermittently and “Approaching Maximum Angle” will appear in the warning message area. The audible alarm will sound continuously whenever the boom is raised above 60 degrees and “Maximum Angle” will appear in warning message area.

To Set Maximum Length Alarm

Example: To have an alarm whenever the boom length exceeds 75 feet, use the following procedure:

1. From the normal working screen, press the Main Menu button .
2. Scroll to Operator Alarms, and press the OK/Enter button .
3. Scroll to Boom Length , and press the OK/Enter button .

4. Extend the boom so that the length is 75 feet.
5. Press the corresponding button for “Max. Length” to set the alarm. The displayed value will be the alarm setting. The  will appear to indicate that the alarm is set.
6. Press the back button  to return to the Operator Alarms menu or press the Working Screen button  again to return to the normal working screen.
7. Test the alarm, with no load, to ensure the alarm points have been properly set. When approaching 75 foot boom length, the audio alarm will sound intermittently and “Approaching Maximum Length” will appear in the warning message area. The audible alarm will sound continuously whenever the boom length exceeds 75 feet and “Maximum Length” will appear in the warning message area.

Operator's Manual

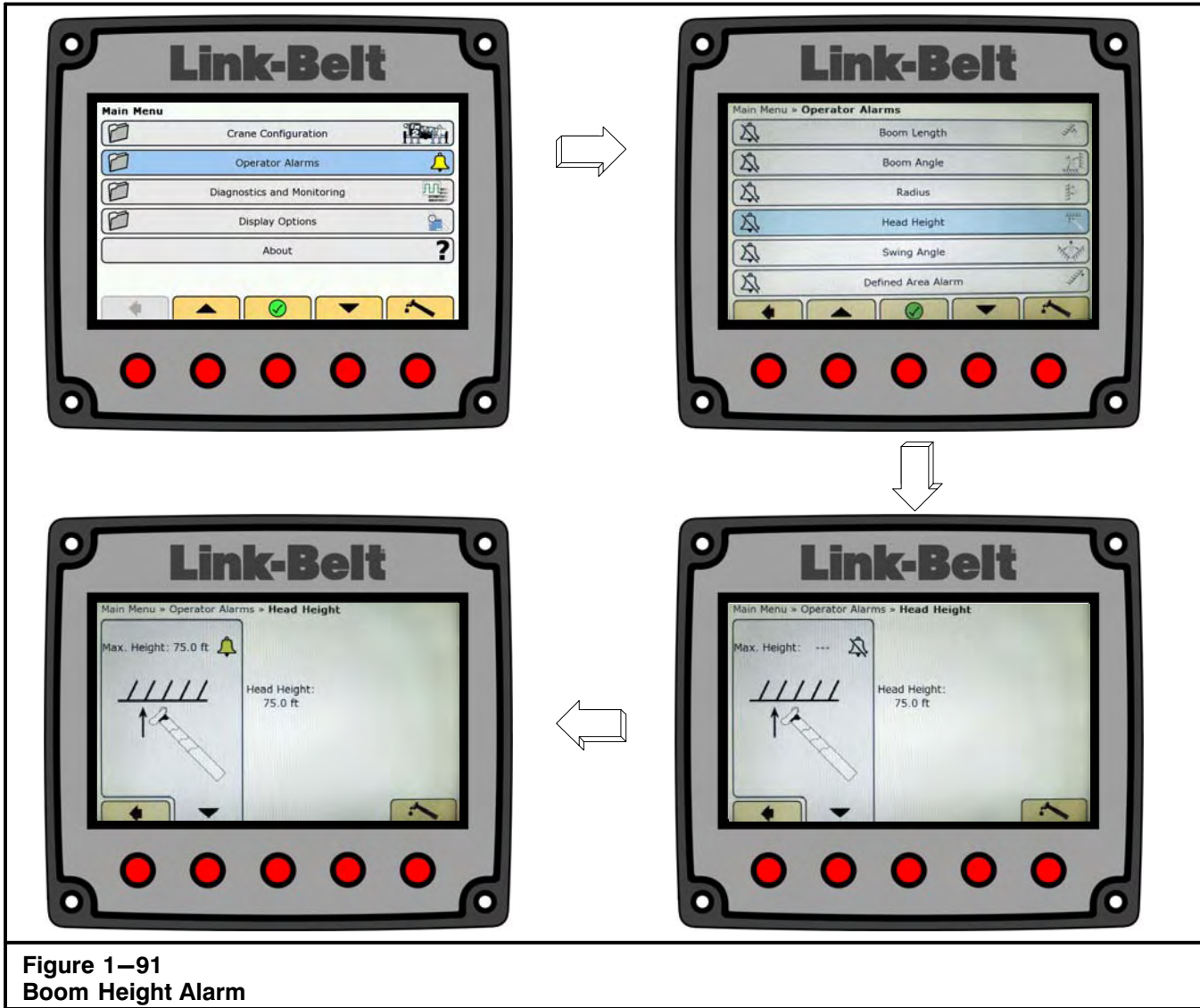









Figure 1-91
Boom Height Alarm

To Set Maximum Height Alarm

Note: The height measured here is from the carrier deck to the tip of the attachment.

Example: To have an alarm whenever the boom tip height exceeds 75 feet, use the following procedure:

1. From the normal working screen, press the Main Menu button .
2. Scroll to Operator Alarms, and press the OK/Enter button .
3. Scroll to Head Height , and press the OK/Enter button .
4. Extend the boom and/or adjust the boom angle so that the head height is 75 feet.
5. Press the corresponding button for "Max. Height" to set the alarm. The displayed value will be the alarm setting. The  will appear to indicate that the alarm is set.
6. Press the back button  to return to the Operator Alarms menu or press the Working Screen button  again to return to the normal working screen.
7. Test the alarm, with no load, to ensure the alarm points have been properly set. When approaching 75 foot boom tip height, the audio alarm will sound intermittently and "Approaching Maximum Height" will appear in the warning message area. The audible alarm will sound continuously whenever the boom tip height exceeds 75 feet and "Maximum Height" will appear in the warning message area.

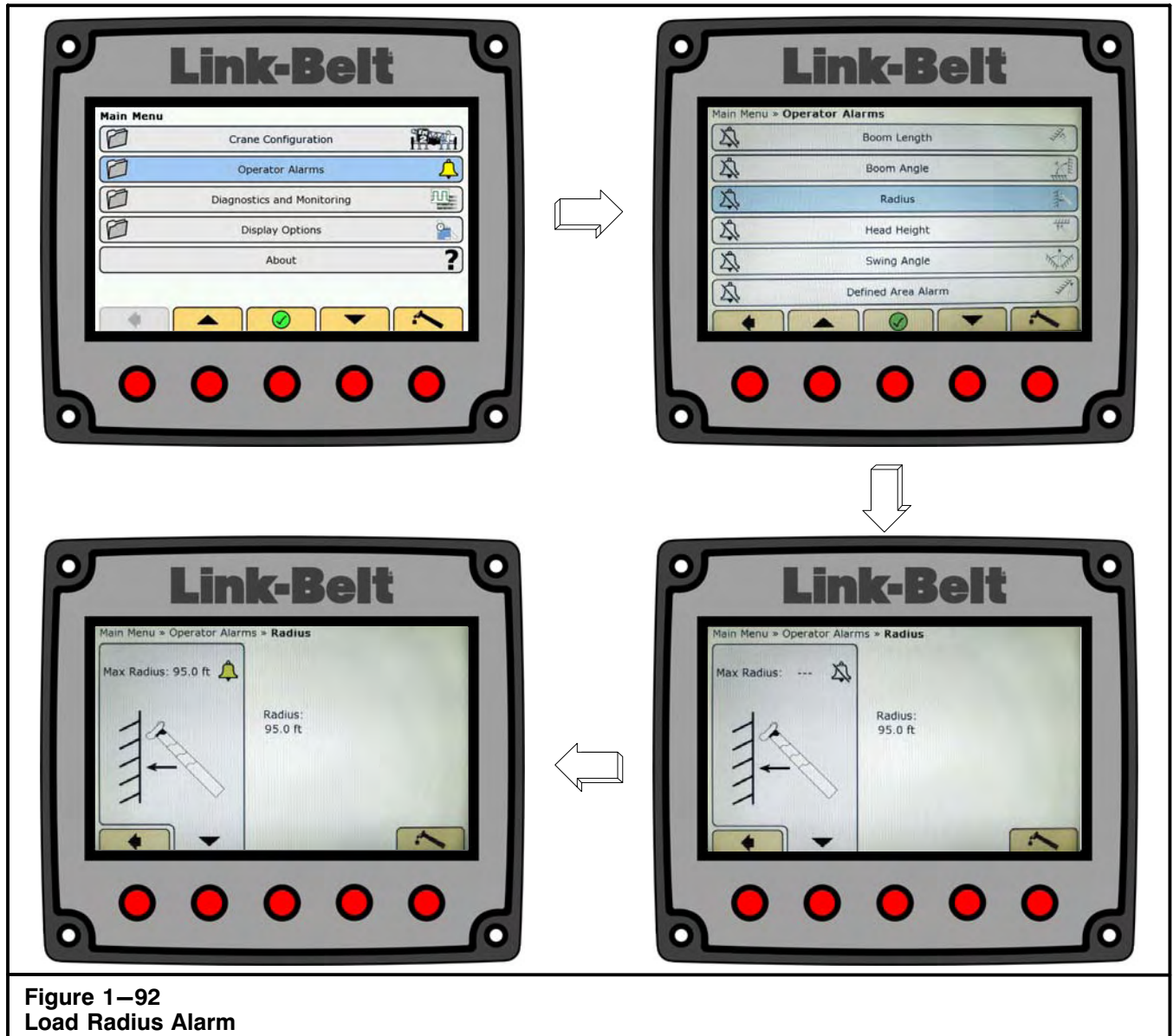









Figure 1-92
Load Radius Alarm

To Set Maximum Radius Alarm

Example: To have an alarm whenever the boom radius exceeds 95 feet, use the following procedure:

1. From the normal working screen, press the Main Menu button .
2. Scroll to Operator Alarms, and press the OK/Enter button .
3. Scroll to Radius , and press the OK/Enter button .
4. Extend the boom and/or adjust the boom angle so that the radius is 95 feet.
5. Press the corresponding button for "Max. Radius" to set the alarm. The displayed value will be the
6. alarm setting. The  will appear to indicate that the alarm is set.
6. Press the back button  to return to the Operator Alarms menu or press the Working Screen button  again to return to the normal working screen.
7. Test the alarm, with no load, to ensure the alarm points have been properly set. When approaching 95 foot boom radius, the audio will sound intermittently and "Approaching Maximum Radius" will appear in the warning message area. The audible alarm will sound continuously whenever the boom radius exceeds 95 feet and "Maximum Radius" will appear in warning message area.

Operator's Manual

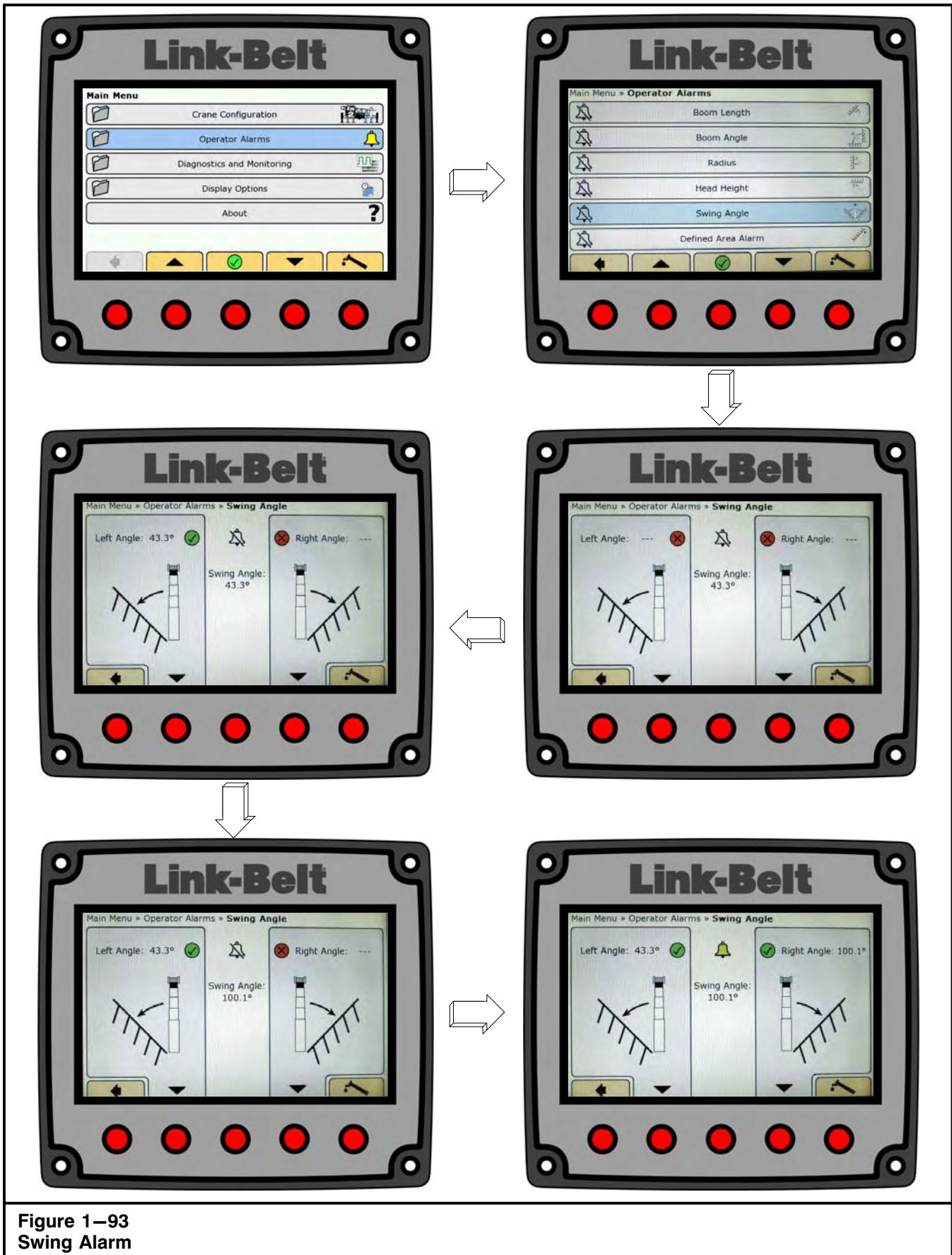











Figure 1–93
Swing Alarm

Operator's Manual

To Set Left And Right Swing Alarms

Example: To have an alarm whenever the LEFT SWING AND RIGHT SWING exceed pre-determined alarm points, use the following procedure:

1. From the normal working screen, press the Main Menu button .
2. Scroll to Operator Alarms, and press the OK/Enter button . Refer to Figure 1–93.
3. Scroll to Swing Angle , and press the OK/Enter button .
4. Swing the boom to the left alarm point.
5. Press the corresponding button for “Left Angle” to enter the left alarm point. The displayed value will be the left alarm setting. The  will appear to indicate that the angle is set.
6. Swing the boom to the right alarm point.
7. Press the corresponding button for “Right Angle” to enter the right alarm point. The displayed value will be the right alarm setting. The  will appear to indicate that the angle is set.
8. When both angles are set, the  will appear to indicate that the alarm is set.
9. Press the back button  to return to the Operator Alarms menu or press the Working Screen button  again to return to the normal working screen.
10. Test the alarm, with no load, to ensure the alarm points have been properly set. When approaching the set alarm point, the audio alarm will sound intermittently and “Approaching Swing Angle Limit” will appear in the warning message area. The audible alarm will sound continuously whenever the swing exceeds the alarm points and “Swing Angle Limit” will appear in warning message area.

Note: Both the left and right swing alarms must be set for the system to determine the operator set working area.

Operator's Manual

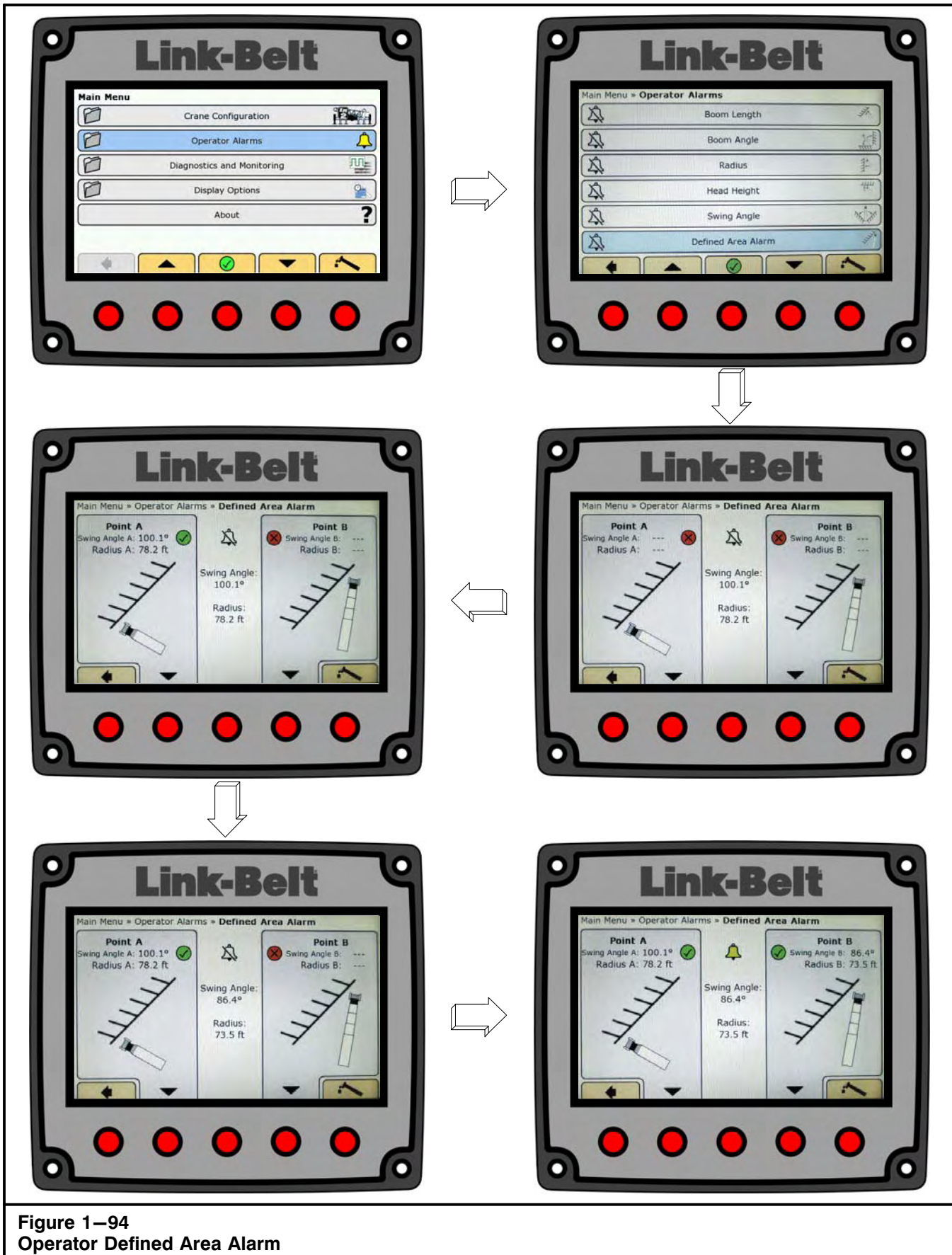

Figure 1-94
Operator Defined Area Alarm

Operator's Manual

Operator Defined Area Alarm



The operator defined area alarm, when set, will define an imaginary vertical plane between two set points to optimize the working area. When approaching the plane, the audio alarm will sound intermittently, and the message "Approaching Defined Area" will appear in the warning message area. When passing the plane, the audio alarm will sound continuously and the message "Defined Area" will appear on the warning message area. Use the following procedure, Figure 1–94, and Figure 1–95 to set the operator defined area alarm.





WARNING

The operator defined area alarm is a warning device. All functions remain operational when entering the operator defined bad area. For safe operation, adequate distance must be maintained to allow for operator reaction time to avoid entering the bad area. It is the responsibility of the operator to set points which ensure that the crane's boom, attachment, load, rigging, etc. maintains a safe working distance and complies with local safety regulations.

Setting Operator Defined Area Alarm

1. From the normal working screen, press the Main Menu button .
2. Scroll to Operator Alarms, and press the OK/Enter button .
3. Disable any previously set left and right swing alarms if required. Refer to "To Disable Operator Settable Alarms" in this Section of this Operator's Manual.

Note: It is recommended to clear the left and right swing alarms prior to setting the defined area alarm.



4. Scroll to Define Area , and press the OK/Enter button .





WARNING

Avoid positioning the boom, attachment, load, rigging, etc. into the bad area when setting the left or right alarm points.

When selecting the left and right alarm points, ensure that the load will maintain a safe distance from the obstacle. Also ensure that the two points are set so that the tailswing of the crane will not enter the bad area.

5. Position the boom, attachment, load, rigging, etc. to the desired Point A and press the corresponding button for "Point A" to set the first point. The displayed values for swing angle and radius will be the set point. The  will appear to indicate that Point A is set.
6. Position the boom, attachment, load, rigging, etc. to the desired Point B and press the corresponding button for "Point B" to set the second point. The displayed values for swing angle and radius will be the set point. The  will appear to indicate that Point B is set.

Note: For best results, the two points should be separated by a minimum of 10 ft (3m) or 30 degrees.







7. When both angles are set, press the back button  to return to the Operator Alarm menu or press the Working Screen button  again to return to the normal working screen.
8. Test the alarm, with no load, to ensure the alarm points have been properly set. When approaching the plane, the audio alarm will sound intermittently and the message "Bad Working Area" will appear on the warning message area. When passing the plane, the audio alarm will sound continuously and the message "Bad Working Area" will appear on the warning message area.



WARNING

If crane or obstacle is moved or if a different size load is lifted, the area alarm must be reset.

To Disable Operator Settable Alarms

1. From the normal working screen, press the Main Menu button .
2. Scroll to Operator Alarms, and press the OK/Enter button .
3. Scroll to the desired alarm to be disabled, and press the OK/Enter button .
4. Press the corresponding button for each alarm. The  icon indicates the alarm has been cleared.
5. When all desired alarms are disabled, press the back button  to return to the Operator Alarm menu or press the Working Screen button  again to return to the normal working screen.

Operator's Manual

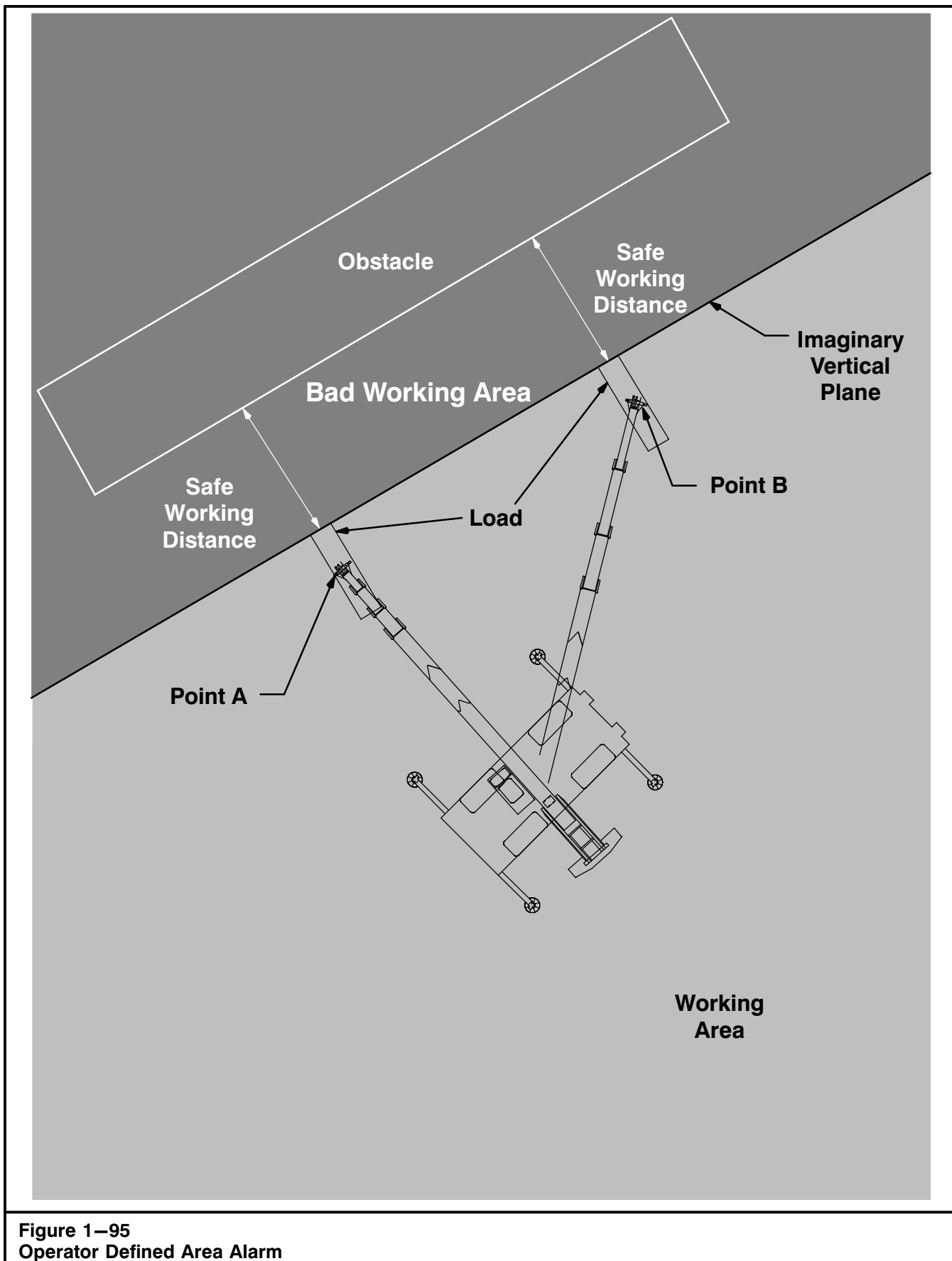

Figure 1-95
Operator Defined Area Alarm

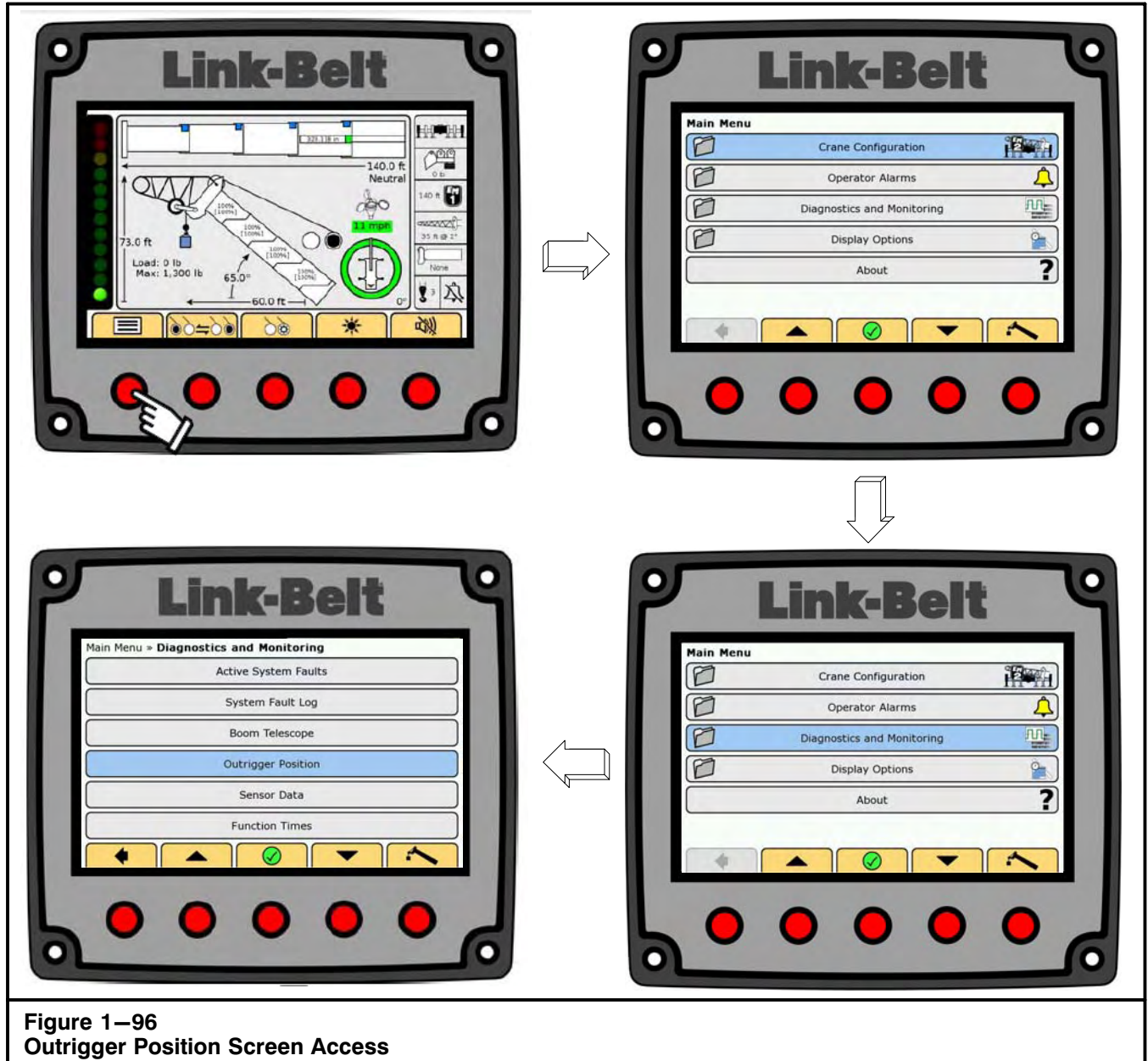





Figure 1-96
Outrigger Position Screen Access

Outrigger Position Screen (If Equipped)

The calibrated position of each outrigger beam will be graphically displayed on the screen. Also the outrigger beam length will be displayed from the centerline of the crane. Refer to Figure 1-96 and Figure 1-97.

1. From the normal working screen, press the Main Menu button .
2. Scroll to Diagnostics, and press the OK/Enter button .
3. Scroll to Outrigger Position and press the OK/Enter button .

WARNING

The outrigger position screen is used to display outrigger beam position. Properly extend the outrigger beams using the outrigger extend position lever/pin to ensure correct outrigger beam position. Failure to do so may cause a loss of stability and possible serious personal injury and/or major crane damage.

!!THIS SCREEN IS AN OPERATOR'S AID – NOT A SAFETY DEVICE!!

Operator's Manual

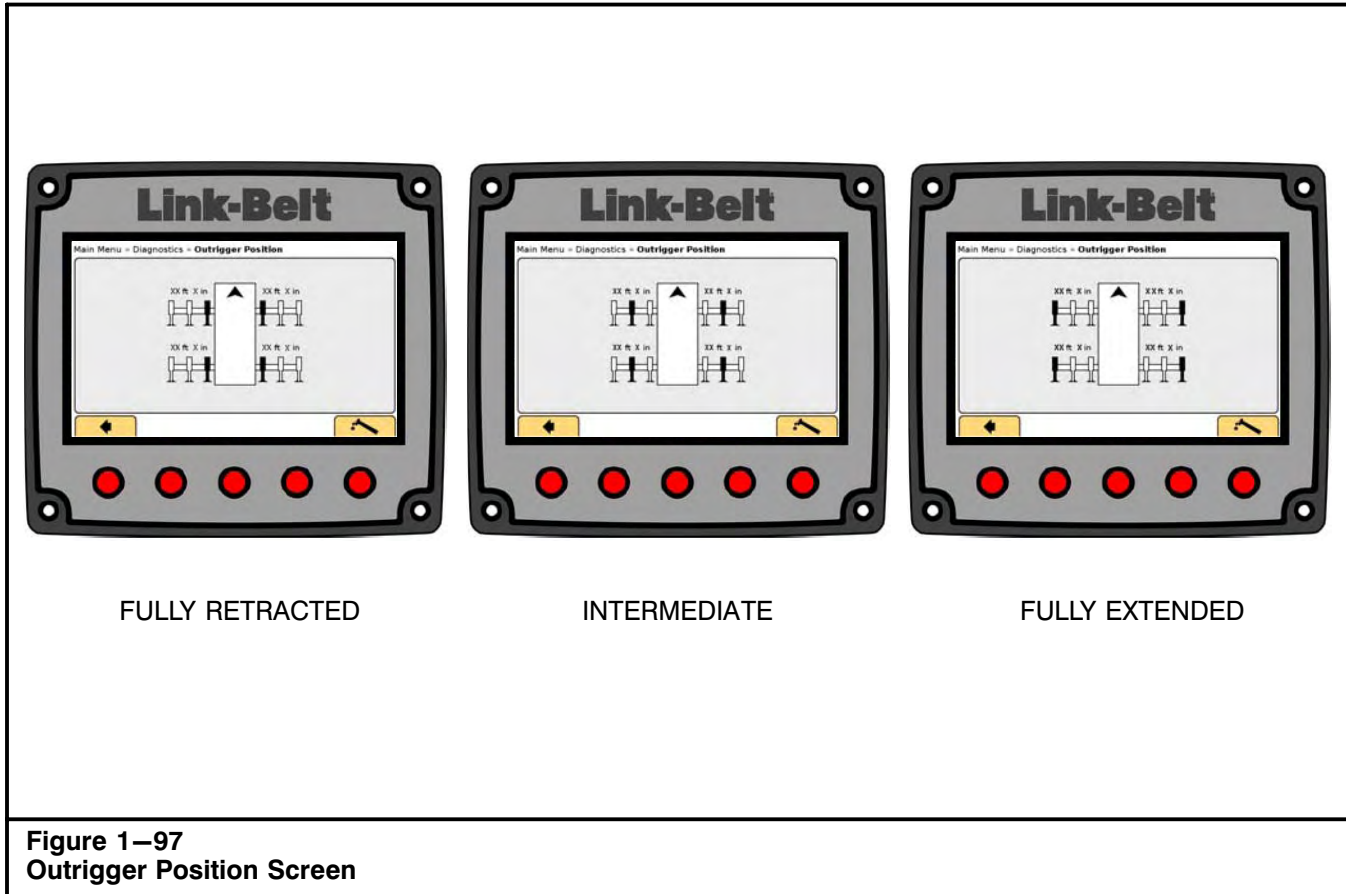

4. Outrigger position and length of each beam, from crane centerline to pontoon centerline, will be displayed.
5. Press the Working Screen Button  to return to the normal working screen.

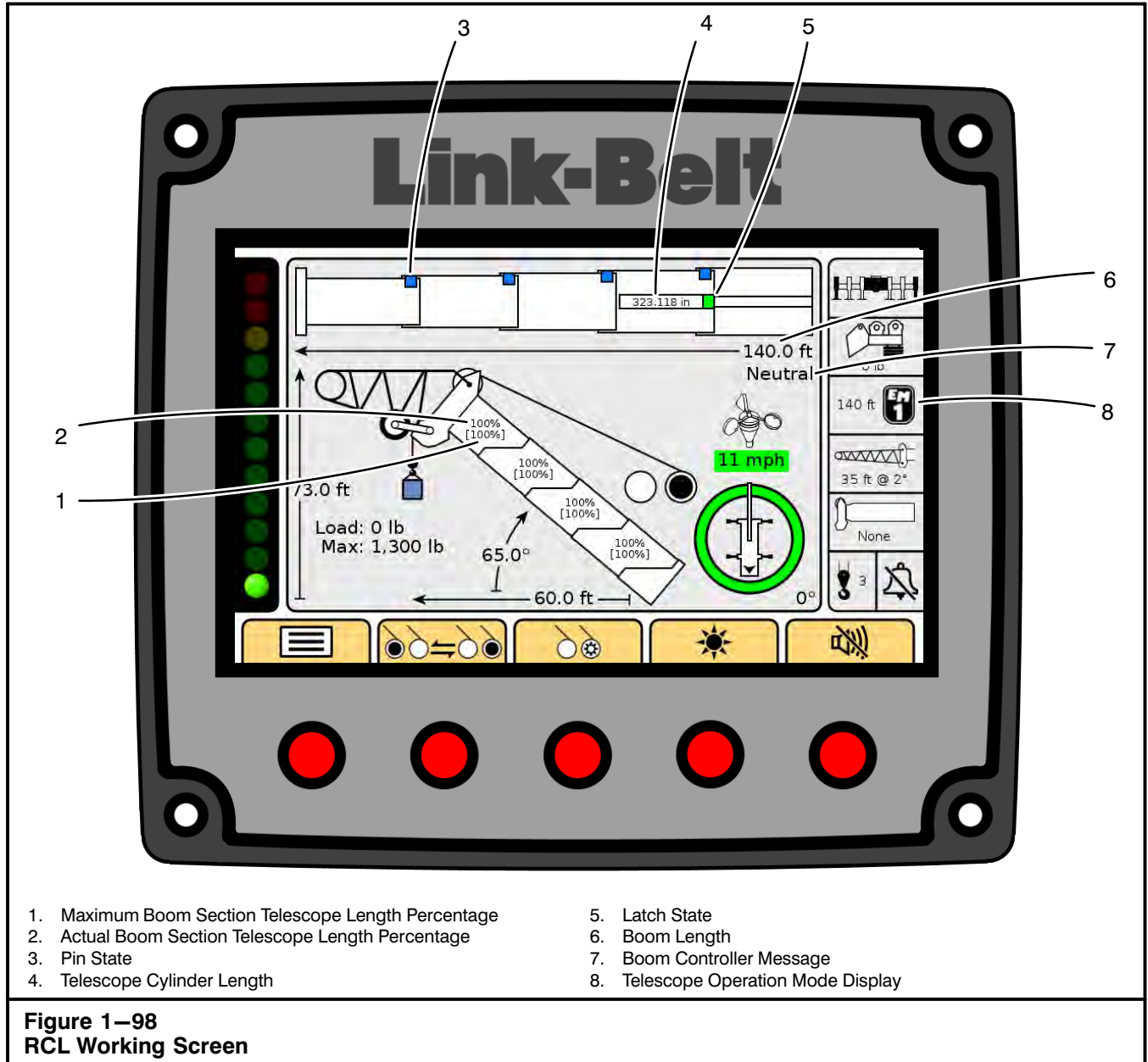

- | | |
|---|-------------------------------------|
| 1. Maximum Boom Section Telescope Length Percentage | 5. Latch State |
| 2. Actual Boom Section Telescope Length Percentage | 6. Boom Length |
| 3. Pin State | 7. Boom Controller Message |
| 4. Telescope Cylinder Length | 8. Telescope Operation Mode Display |

Boom Telescope Animation Display

Visual feedback about what is occurring while telescoping the boom is displayed on the main RCL Working Screen. Refer to Figure 1-98. The screen will display a graphic representation of the boom and will display the boom length in feet, the telescope cylinder location in inches, the pin and the latch status, and boom extension mode. Press the Main Menu button on the RCL Display to access CAN BUS information, error messages, and other diagnostic information. Refer to "Active System Faults" and "Boom Telescope Diagnostics" in this Section of this Operator's Manual.

1. Maximum Boom Section Telescope Length Percentage

Maximum Boom Section Telescope Length Percentage displays the current section length as a percentage of its absolute maximum length not in the current boom mode.

Operator's Manual

2. Actual Boom Section Telescope Length Percentage

Actual Boom Section Telescope Length Percentage displays the maximum length for each section in the current boom mode shown in brackets.

3. Pin State

Pin State graphically shows the pin status as pinned or not pinned.

4. Telescope Cylinder Length

Telescope Cylinder Length shows a numeric readout of the telescope cylinder length in inches (*cm*).

3. Latch State

Latch State graphically shows the latch status as latched or not latched.

6. Boom Length Display

The Boom Length Display gives a continuous indication of the boom length in feet (*m*). It is the distance from the centerline of the boom foot pin to the centerline of the boom head machinery.

7. Boom Controller Message

The Boom Controller Message displays the most recent message sent from the boom controller. This message may contain operation messages or error messages.

8. Boom Extension Mode

This area displays the current boom extension mode. It also shows the maximum boom length for the current boom extension mode.

Operator's Manual

Boom Operating Messages

The following chart lists the operation messages that may appear in the boom controller message area of RCL Display during crane operations.

| Normal Operation Messages | | |
|---------------------------|--|---|
| StopExt | Boom Stop Extend | Boom has finished extending. No further action is required. |
| E_PLB | Extend – Pin Latch Bottom During boom extend operation, pin/latch state is PINNED and NOT LATCHED. | Telescope cylinder is centering the latches in the next section to extend. |
| E_Ext | Extend – Boom Extend Extending boom at speed proportional to extend pedal input. | Section is LATCHED to telescope cylinder and NOT PINNED. Boom will not enter this condition unless pin/latch state is NOT PINNED and LATCHED. |
| E_PLT | Extend – Pin Latch Top During boom extend operation, pin/latch state is PINNED and LATCHED. | Pin should be fully engaged in the hole and the telescope cylinder is retracting to gently load up the pin and unload the latches so they disengage from the section. |
| E_Ret | Extend – Cylinder Retract Telescope cylinder is retracting at maximum speed to line up with the next section to be extended. | Boom is PINNED and NOT LATCHED. Telescope cylinder moves at maximum speed regardless of pedal position within retract range. Boom will not enter this condition unless pin/latch state is PINNED and NOT LATCHED. |
| StopRet | Boom Stop Retract | Boom has finished retracting. No further action is required. This is only shown during a boom mode change. |
| R_PLB | Retract – Pin Latch Bottom During boom retract operation, pin/latch state is PINNED and LATCHED. | Pin should be fully engaged in the pin hole in the adjacent boom section and the telescope cylinder is centering the latches to unload them so they disengage from the section. |
| R_Ext | Retract – Boom Extend Retracting boom at speed proportional to retract pedal input. | Boom section is LATCHED to telescope cylinder and NOT PINNED. Boom will not enter this condition unless pin/latch state is NOT PINNED and LATCHED. |
| R_PLT | Retract – Pin Latch Top During boom retract operation, pin/latch state is PINNED and NOT LATCHED. | Telescope cylinder is centering the latches in the next section to retract. |
| R_Ret | Retract – Cylinder Retract Telescope cylinder is extending at maximum speed to line up with the next section to be retracted. | Boom is PINNED and NOT LATCHED. Telescope cylinder moves at maximum speed regardless of pedal position within retract range. Boom will not enter this condition unless pin/latch state is PINNED and NOT LATCHED. |
| Wt4Pin | Wait for PINNED signal | Telescope cylinder has reached the pinning location and stopped moving. Cylinder is Latched and state has changed to PINNED. Computer is waiting for a PINNED switch signal. |
| Wt4PPul | Wait for NOT PINNED signal | Telescope cylinder is Latched to the boom section and has unloaded the pin. Cylinder movement is stopped. Computer is waiting for a NOT PINNED switch signal. |

Operator's Manual

| Normal Operation Messages | | |
|---------------------------|--|--|
| Wt4Ltch | Wait for LATCHED signal | Telescope cylinder is centered on the latching location and stopped moving. State has changed to LATCHED . Computer is waiting for a LATCHED switch signal. |
| Wt4LPul | Wait for NOT LATCHED signal | Telescope cylinder is centered on the latching location and stopped moving. The boom section is PINNED to the adjacent section. State has changed to NOT LATCHED. Computer is waiting for a NOT LATCHED switch signal. |
| Re-Zero | Re-Zero telescoping boom | A switch error has occurred causing the possibility of incorrect boom extension. Manually retract all the boom sections and retract the telescope cylinder until it bottoms out while PINNED and NOT LATCHED. Re-Zero the length of the telescope cylinder at this point. This resets the boom length and cylinder location. |
| Neutral | Telescope pedal is centered. | No input from the operator is being sensed by the controller. |
| Release | Pin and unlatch from incorrect section | Telescope cylinder is not lined up with correct section to be moved. Controller is automatically pinning and unlatching from the incorrect section and moving to line up with correct section. |
| ExtSlwL | Slow Extend while latching and not pinning | Unpinning a boom section that is incorrectly pinned to the adjacent boom section upon start-up of the crane. |
| LkOutSw | Function lockout switch is activated | Function lockout switch is activated. |
| ArmRest | Arm rest switch is activated | The arm rest is up causing functions to be disabled. |
| PdlCtr? | Telescope foot pedal is not centered when expected | Telescope foot pedal is not centered upon machine start-up. |
| AutoSRB | (Automatic) slow retract button | During extend mode changes the telescope cylinder pins off the section it is currently attached to and goes to the correct boom section. |
| AutoPLB | (Automatic) slow pin–latch button | During extend mode changes the telescope cylinder pins off the section it is currently attached to and goes to the correct boom section. |
| ovrLoad | Overload condition is active and extend function is disabled | Winch down, boom hoist down to reduce load. |
| atbKo | ATB is triggered and extend function is disabled | Winch down or retract boom. |
| flyKo | Fly extend sensor is triggered and extend function is disabled | Retract boom. |

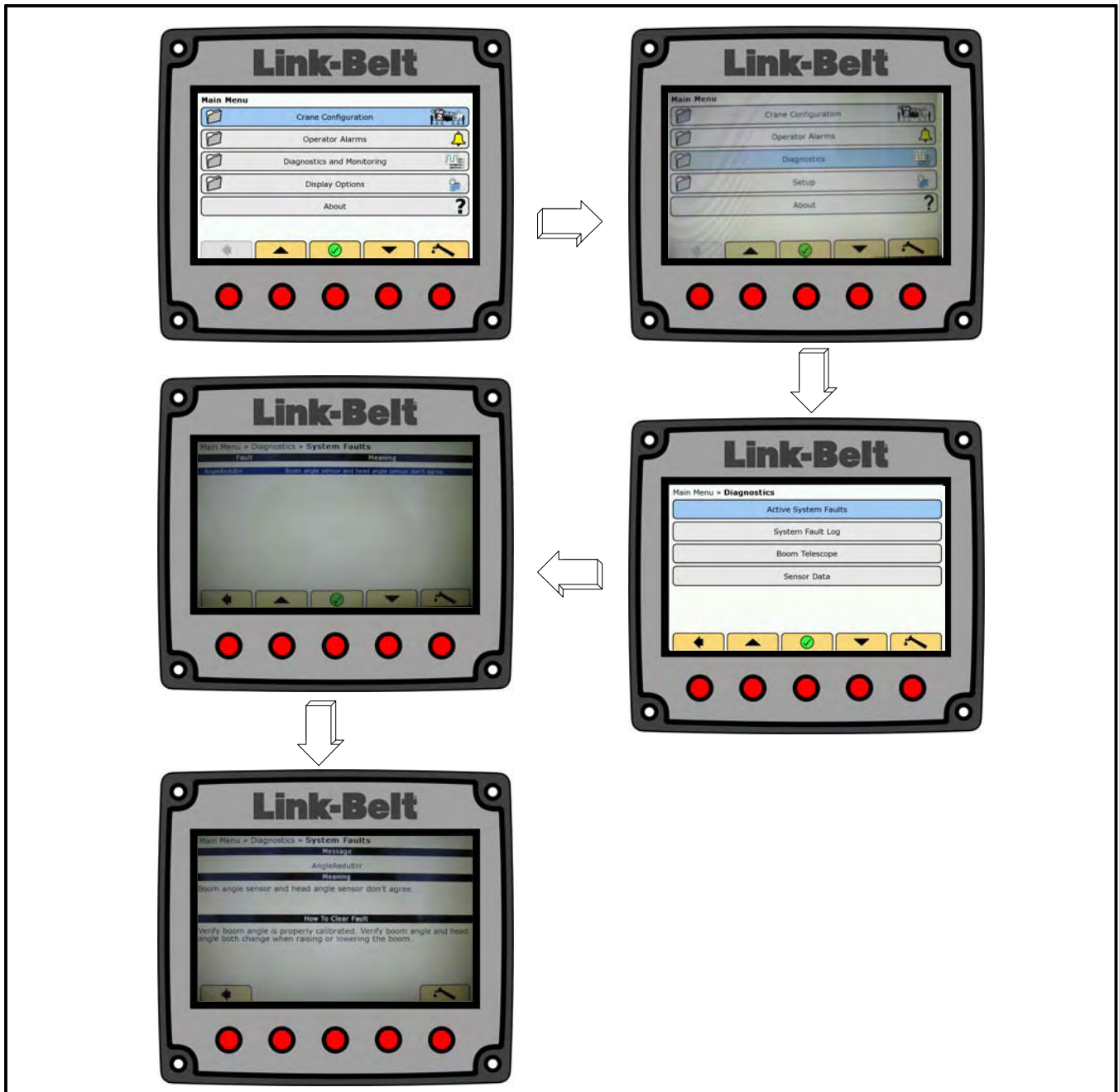







Figure 1–99
Active System Faults

Active System Faults

The Active System Faults menu can be displays current system faults. Refer to Figure 1–99 and the System Faults Messages chart.

1. From the normal working screen, press the Main Menu button .
2. Scroll to Diagnostics, and press the OK/Enter button .
3. Scroll to Active System Faults, and press the OK/Enter button .
4. Scroll to the fault code to be addressed, and press the OK/Enter button .
5. The message selected, meaning of the message, and how to clear the message will be displayed.
6. Press the back button  to return to the System Faults menu or press the Working Screen button  to return to the normal working screen.

Operator's Manual

| Active System Faults Messages | | |
|-------------------------------|--|---|
| Message | Meaning | How To Clear Message |
| DispComErr | Display communication lost. | Verify display is properly connected to the CAN bus. Check all CAN bus wiring including termination resistors. |
| ATBComErr | ATB switch communication lost. | Verify boom reel is properly connected to the CAN bus. Check all CAN bus wiring including termination resistors. |
| ATBShort | ATB switch short circuit. | Verify ATB switch is functioning properly. Check wiring between ATB switch and boom reel. |
| LenComErr | Boom length sensor communication lost. | Verify boom reel is properly connected to the CAN bus. Check all CAN bus wiring including termination resistors. |
| LenDataErr | Boom length sensor data is invalid. | Verify boom length is properly calibrated. Verify boom length value changes when extending or retracting the boom. |
| LenReduErr | Boom length sensor and boom controller length don't agree. | Verify boom length and boom controller are properly calibrated. Verify sensor boom length and boom controller length both change when extending or retracting the boom. |
| AngleComErr | Boom angle sensor communication lost. | Verify boom reel is properly connected to the CAN bus. Check all CAN bus wiring including termination resistors. |
| AngleDataErr | Boom angle sensor data is invalid. | Verify boom angle is properly calibrated. Verify boom angle value changes when raising or lowering the boom. |
| AngleReduErr | Boom angle sensor and head angle sensor don't agree. | Verify boom angle is properly calibrated. Verify boom angle and head angle both change when raising or lowering the boom. |
| HeadComErr | Head angle sensor communication lost. | Verify boom reel is properly connected to the CAN bus. Check all CAN bus wiring including termination resistors. |
| HeadDataErr | Head angle sensor data is invalid. | Verify head angle is properly calibrated. Check wiring between head angle sensor and boom reel. Verify head angle changes when raising or lowering the boom. |
| HPresComErr | Head pressure sensor communication lost. | Verify head pressure sensor is properly connected to the CAN bus. Check all CAN bus wiring including termination resistors. |
| RPresComErr | Rod pressure sensor communication lost. | Verify rod pressure sensor is properly connected to the CAN bus. Check all CAN bus wiring including termination resistors. |
| DispIOComErr | Display I/O communication lost. | Verify display is properly connected to the CAN bus. Check all CAN bus wiring including termination resistors. |
| BoomComErr | Boom controller communication lost. | Verify boom controller is properly connected to the CAN bus. Check all CAN bus wiring including termination resistors. |

Operator's Manual

| Active System Faults Messages | | |
|-------------------------------|---|---|
| Message | Meaning | How To Clear Message |
| Boom100Err | Internal error in boom controller | Cycle power. Check power and ground to controller. Re-Zero telescope cylinder. |
| Boom101Err | NOT PINNED and NOT LATCHED sensors are both closed. | Check power and ground to sensors and signal back from sensors. Check wire harness. Check mechanical interlock. |
| Boom102Err | NOT PINNED and PINNED sensors are both closed. | Check power and ground to sensors and signal back from sensors. Check wire harness. |
| Boom103Err | LATCHED and NOT LATCHED sensors are both closed. | Check power and ground to sensors and signal back from sensors. Check wire harness. |
| Boom106Err | PINNED switch is closed during Boom Extend portion of the cycle. | Check power and ground to sensors and signal back from sensors. Check wire harness. |
| Boom107Err | LATCHED sensor is closed during Retract Cylinder portion of the cycle. | Check power and ground to sensors and signal back from sensors. Check wire harness. |
| Boom108Err | Telescope cylinder encoder 1 and telescope cylinder encoder 2 are both not received. | Check power and ground to encoders. Check CAN harness from encoders. Check encoders. |
| Boom109Err | Telescope extend, retract, latch, not latch, pin, or not pin coils are over current limit. | Check the wire harness between the controller and the telescope valve. Check the coils in the telescope valve. |
| Boom110Err | Telescope cylinder cycled > 3 times trying to obtain both latch present forward and latch present rear sensors. | Repair boom hose reel. Check power and ground to reel rotation sensor. |
| Boom201Err | Input goes beyond the usable range defined for the foot pedal. | Back off on the amount that you stroke the telescope pedal. Check telescope pedal and replace as required. Adjust telescope pedal stops. Ensure the left console is down and function enable switch is closed. |
| Boom205Err | Boom hose reel stops turning and gets slack in the hoses and cable. | Repair boom hose reel. Check power and ground to reel rotation sensor |
| Boom206Err | No LATCH PRESENT sensor signal at some point when: <ul style="list-style-type: none"> • E_PLB and R_PLB, mode and cylinder is between PIN – REAR LIMIT PIN and PIN + FRONT LIMIT PIN. • E_PLT and R_PLT mode and cylinder is between LATCH – REAR LIMIT LATCH and LATCH + FRONT LIMIT LATCH. • The LATCHED sensor is closed. • The NOT PINNED sensor is closed. | Check power and ground to sensors and signal back from sensors. Check wire harness. Check sensor adjustments. |

Operator's Manual

| Active System Faults Messages | | |
|-------------------------------|--|---|
| Message | Meaning | How To Clear Message |
| Boom208Err | PINNED sensor is closed but not LATCHED, NOT LATCHED, or LATCH PRESENT sensors. | Check power and ground to sensors and signal back from sensors. Check wire harness. |
| Boom209Err | If NOT PINNED sensor signal is lost during E_Ext or R_Ext after sensor timeout period and the state is still NOT PINNED. | Check power and ground to sensors and signal back from sensors. Check wire harness. |
| Boom301Err | Boom lengths don't match within 1 ft between the RCL System and the telescope system. | Check reels for correct cable spooling. Look for any reason the reel would not show the correct boom length. Re-zero reels. |
| Boom302Err | Unexpected LATCH PRESENT sensor signal. There is a LATCH PRESENT sensor input that is true when the sensor inputs indicate Pinned and Not Latched and the cylinder position is between PIN POSITION + FRONT LIMIT PIN + 12 in and LATCH POSITION – REAR LIMIT LATCH – 12 in. | Check power and ground to sensors and signal back from sensors. Check wire harness. |
| Boom307Err | If Encoder2 is below –0.3 inches from the calibrated zero length Home Position and the controller is using Encoder1. | Check power and ground to encoders. Check CAN harness from encoders. Check encoders. |
| Boom308Err | If Encoder2 is more than 395 inches from the calibrated zero length Home Position and the controller is using Encoder1. Operation can continue until Encoder2 is repaired. | Check power and ground to encoders. Check CAN harness from encoders. Check encoders. |
| Boom309Err | If Encoder2 is not received and the controller is using Encoder1. Operation can continue until Encoder2 is repaired. | Check power and ground to encoders. Check CAN harness from encoders. Check encoders. |
| Boom310Err | If Encoder1 is below –0.3 inches from the calibrated zero length Home Position and the controller is using Encoder2. Operation can continue until Encoder1 is repaired. | Check power and ground to encoders. Check CAN harness from encoders. Check encoders. |
| Boom311Err | If Encoder1 is more than 395 inches from the calibrated zero length Home Position and the controller is using Encoder2. Operation can continue until Encoder1 is repaired. | Check power and ground to encoders. Check CAN harness from encoders. Check encoders. |
| Boom312Err | If Encoder1 is not received and the controller is using Encoder2. Operation can continue until Encoder1 is repaired. | Check power and ground to encoders. Check CAN harness from encoders. Check encoders. |
| Boom313Err | If Encoder1 is not equal to Encoder2 by more than 0.4 inch and the controller is using Encoder1. | Check power and ground to encoders. Check CAN harness from encoders. Check encoders. |
| Telematic-sModComErr | Telematics module communication lost. | Verify telematics module is properly connected to the CAN bus. Check all CAN bus wiring including termination resistors. |

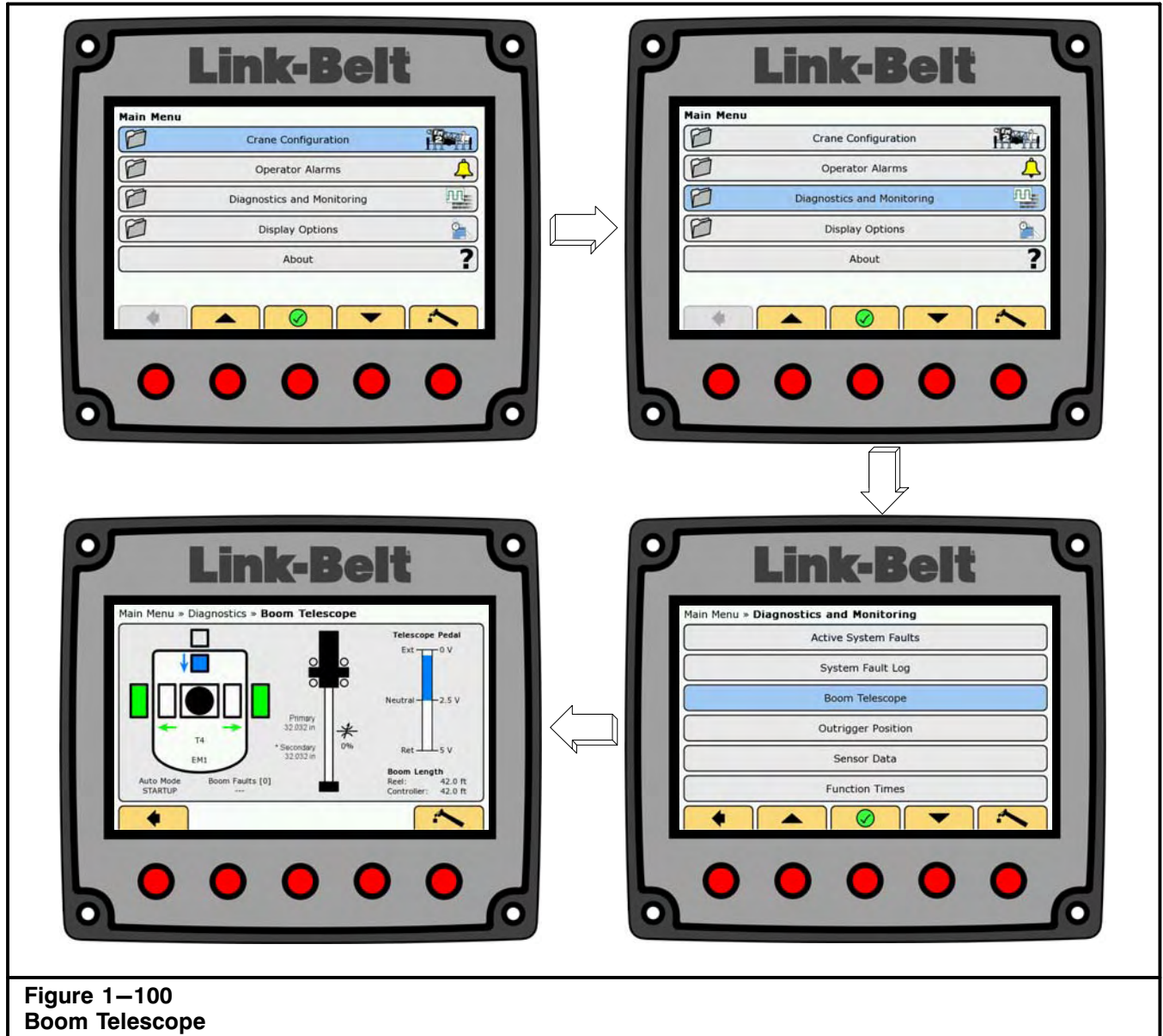







Figure 1-100
Boom Telescope

Boom Telescope Diagnostics

The Boom Telescope menu displays current boom diagnostic data. Refer to Figure 1-100, Figure 1-101, and the Boom Faults Messages chart.

1. From the normal working screen, press the Main Menu button .
2. Scroll to Diagnostics, and press the OK/Enter button .

3. Scroll to Boom Telescope, and press the OK/Enter button .
4. Press the back button  to return to the Boom Diagnostic menu or press the Working Screen button  to return to the normal working screen.

Operator's Manual

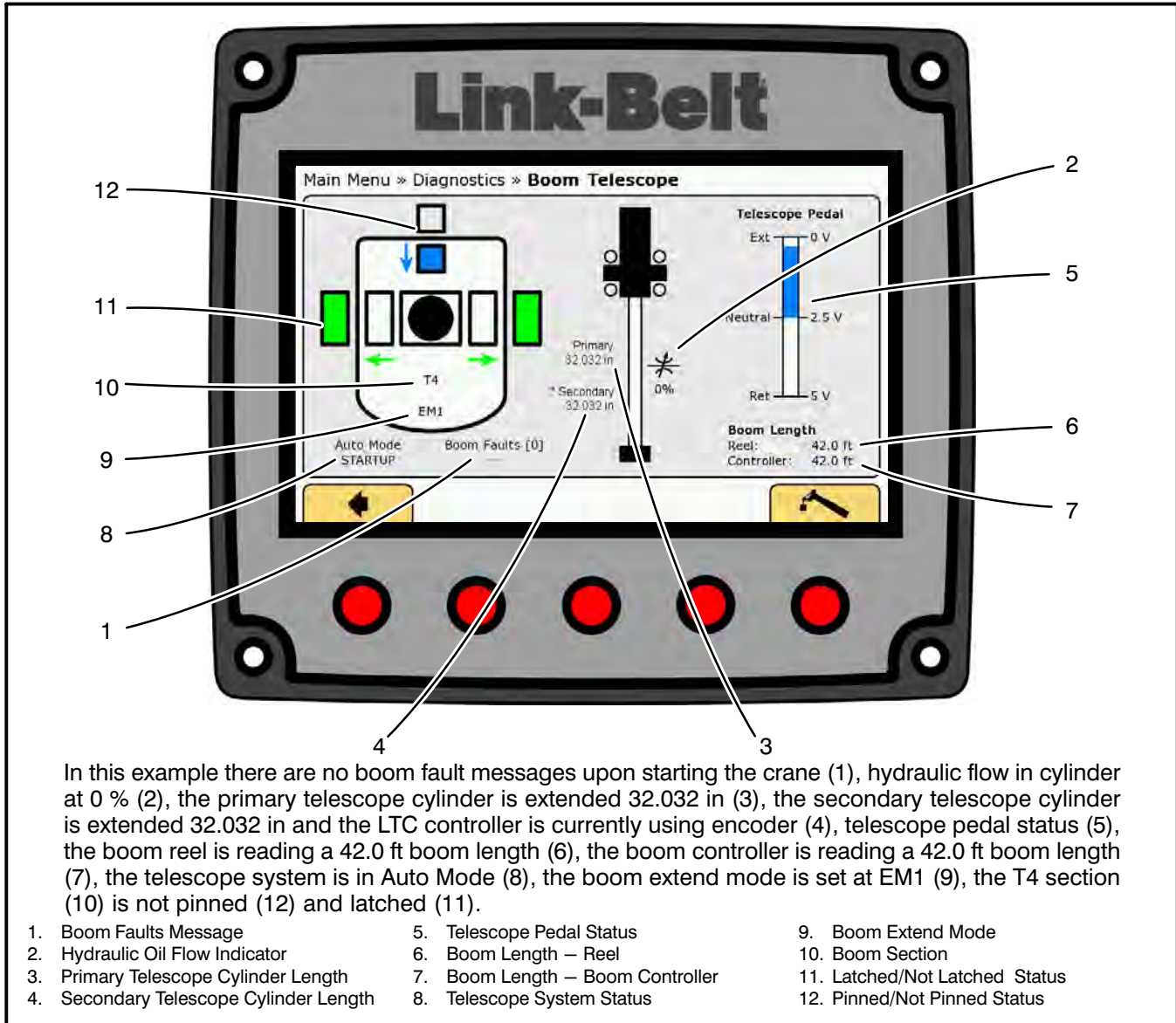

**Figure 1–101
Boom Telescope Diagnostics Screen**

Boom Telescope Diagnostics Screen

The following is a description of the images represented on the RCL Display unit when in the Boom Telescope Diagnostics menu. Use them along with Figure 1–101.

1. Boom Faults Message

Any current boom fault messages will appear in this area. Refer to Boom Faults and Figure 1–100 in this Section of this Operator's Manual.

2. Hydraulic Oil Flow Indicator

This indicator shows the hydraulic oil flow rate in the telescope cylinder.

3. Primary Telescope Cylinder Length

The Primary Telescope Cylinder Length gives a continuous indication of the Primary telescope cylinder length in inches. * - indicates Latching Telescope Controller (LTC) is currently using encoder.

4. Secondary Telescope Cylinder Length

The Secondary Telescope Cylinder Length gives a continuous indication of the secondary telescope cylinder length in inches. * - indicates Latching Telescope Controller (LTC) is currently using encoder.

5. Telescope Pedal Status

This displays the status of the telescope pedal.

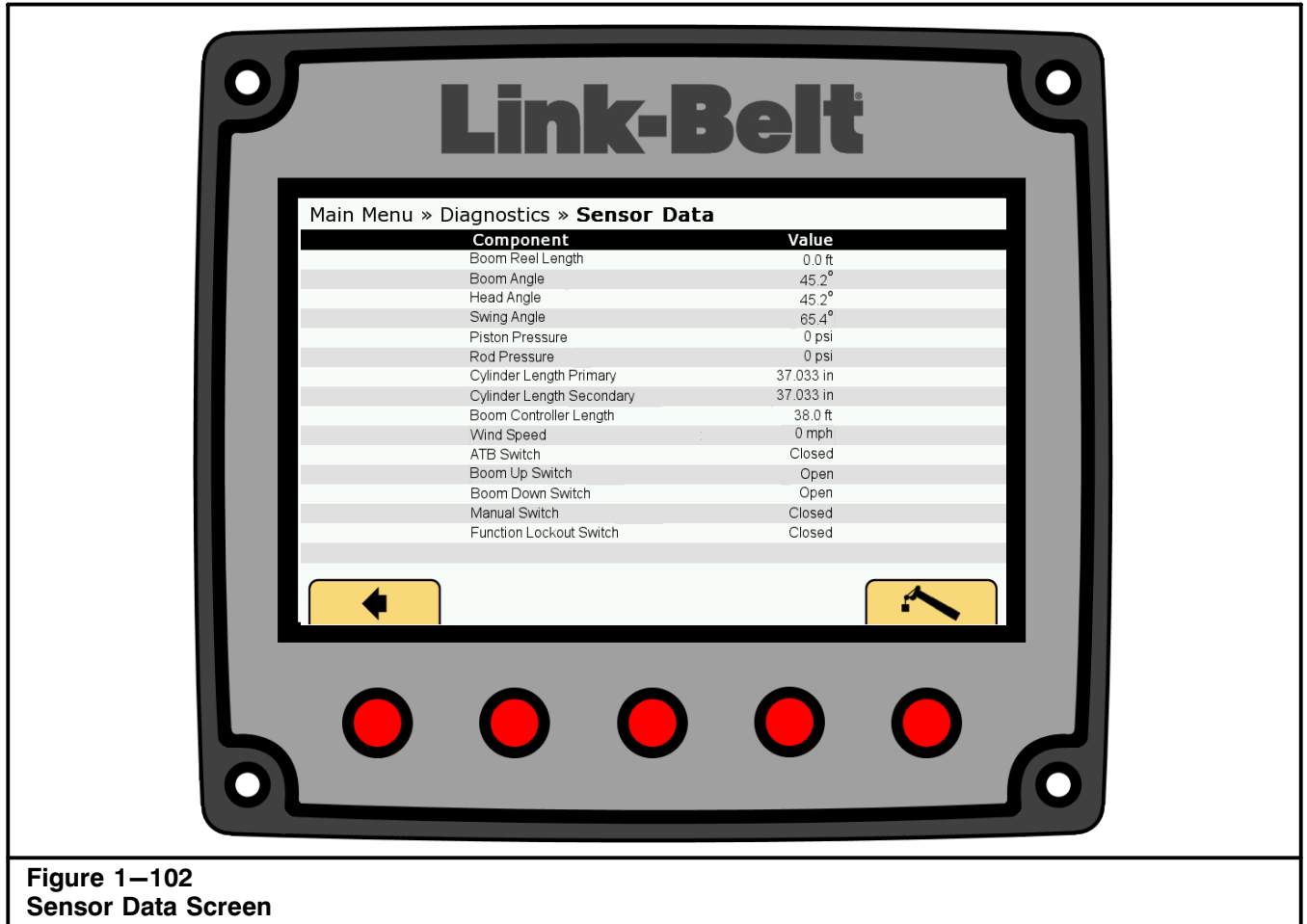

Figure 1–102
Sensor Data Screen

6. Boom Length – Reel

This area displays a continuous indication of the boom length in feet as read by the boom reel.

7. Boom Length – Boom Controller

This area displays a continuous indication of the boom length in feet as read by the boom controller.

8. Telescope System Status

This displays the status of the telescope system, Auto Mode or Manual Mode.

9. Boom Extend Mode

The current boom extend mode is displayed here.

10. Boom Section

This area displays the boom section that is currently being pinned/latched.

11. Latched/Not Latched Status

This is a graphic representation of the current latched/not latched status. When the section is latched, the





outer boxes will be shaded. When the section is not latched, the inner boxes will be shaded.

12. Pinned/Not Pinned Status

This is a graphic representation of the current pinned/not pinned status. When the section is pinned, the top box will be shaded. When the section is not pinned, the inner box will be shaded.

Sensor Data

The Sensor Data menu displays data being read by various sensors on the crane. Refer to Figure 1–102.

1. From the normal working screen, press the Main Menu button .
2. Scroll to Diagnostics, and press the OK/Enter button .
3. Scroll to Sensor Data, and press the OK/Enter button .
4. The data being generated by the various sensors will be displayed.
5. Press the back button  to return to the Diagnostics menu or press the Working Screen button  to return to the normal working screen.

Operator's Manual

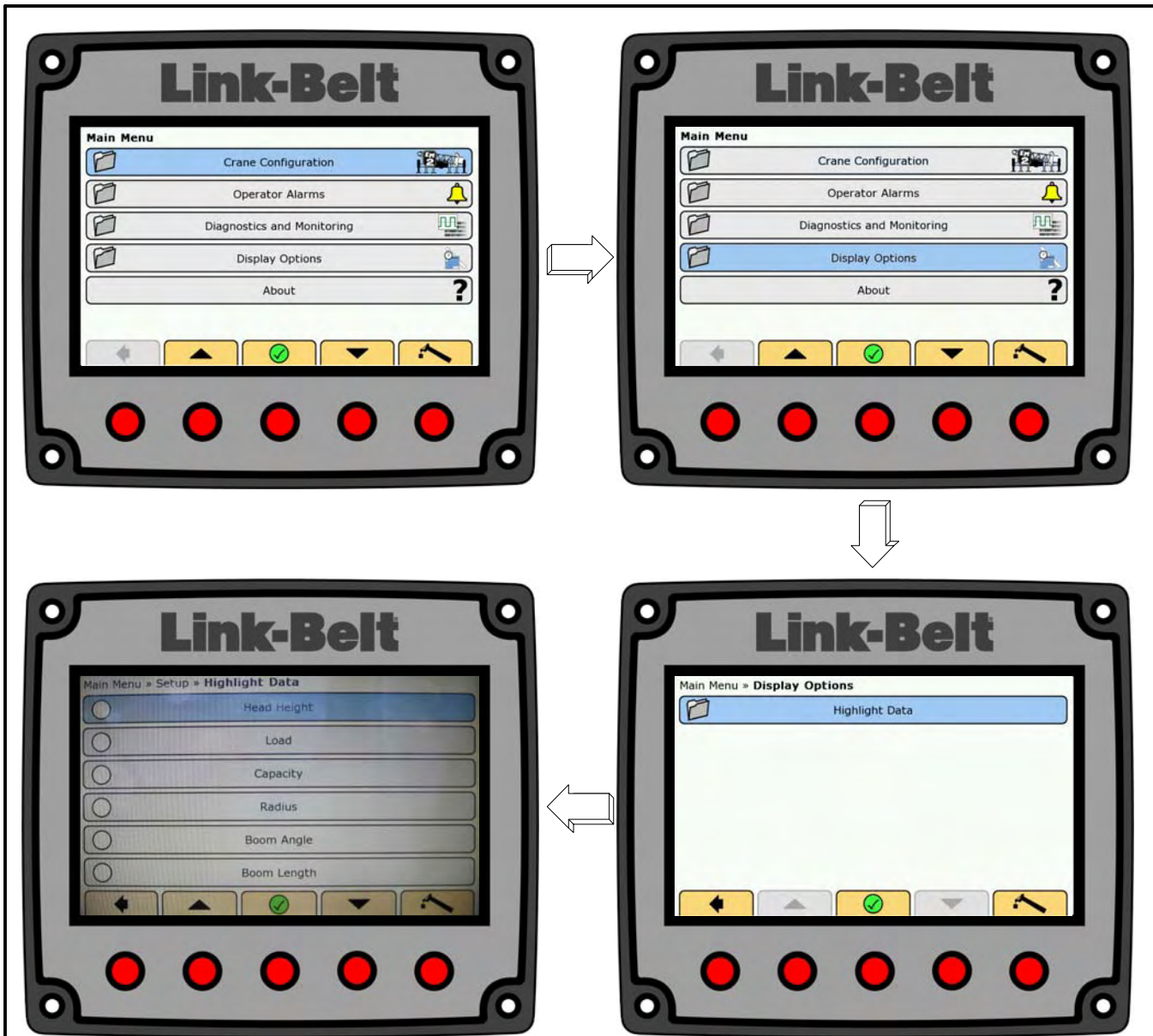









Figure 1–103
Highlight Data

Highlight Data Menu

The Highlight Data menu allows the Operator to select specific data to be highlighted on the normal working screen. The data will appear with a purple highlighting. Refer to Figure 1–103.

1. From the normal working screen, press the Main Menu button .
2. Scroll to Crane Configuration, and press the OK/Enter button .

3. Scroll to Setup, and press the OK/Enter button .
4. Scroll to Highlight, and press the OK/Enter button .
5. Scroll to the information to be highlighted, and press the OK/Enter button .
6. Repeat Step 5 for each item to be highlighted.
7. Press the back button  to return to the Setup menu or press the Working Screen button  to return to the normal working screen.

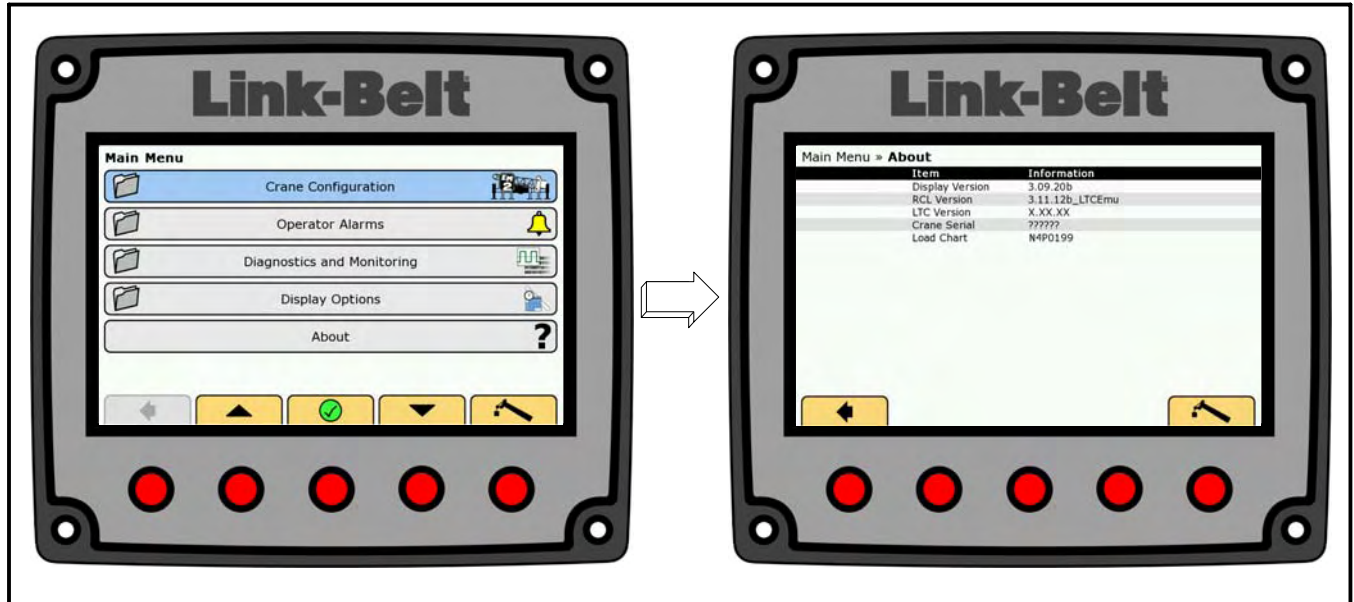





Figure 1–104
About Screen

About Menu

The About menu displays which version of the Display, ECM, and Boom Controller software is currently installed. Refer to Figure 1–104. The machine serial number is also displayed on this screen.

1. From the normal working screen, press the Main Menu button .
2. Scroll to About, and press the OK/Enter button .
3. Press the back button  to return to the Main menu or press the Working Screen button  to return to the normal working screen.

Operator's Manual

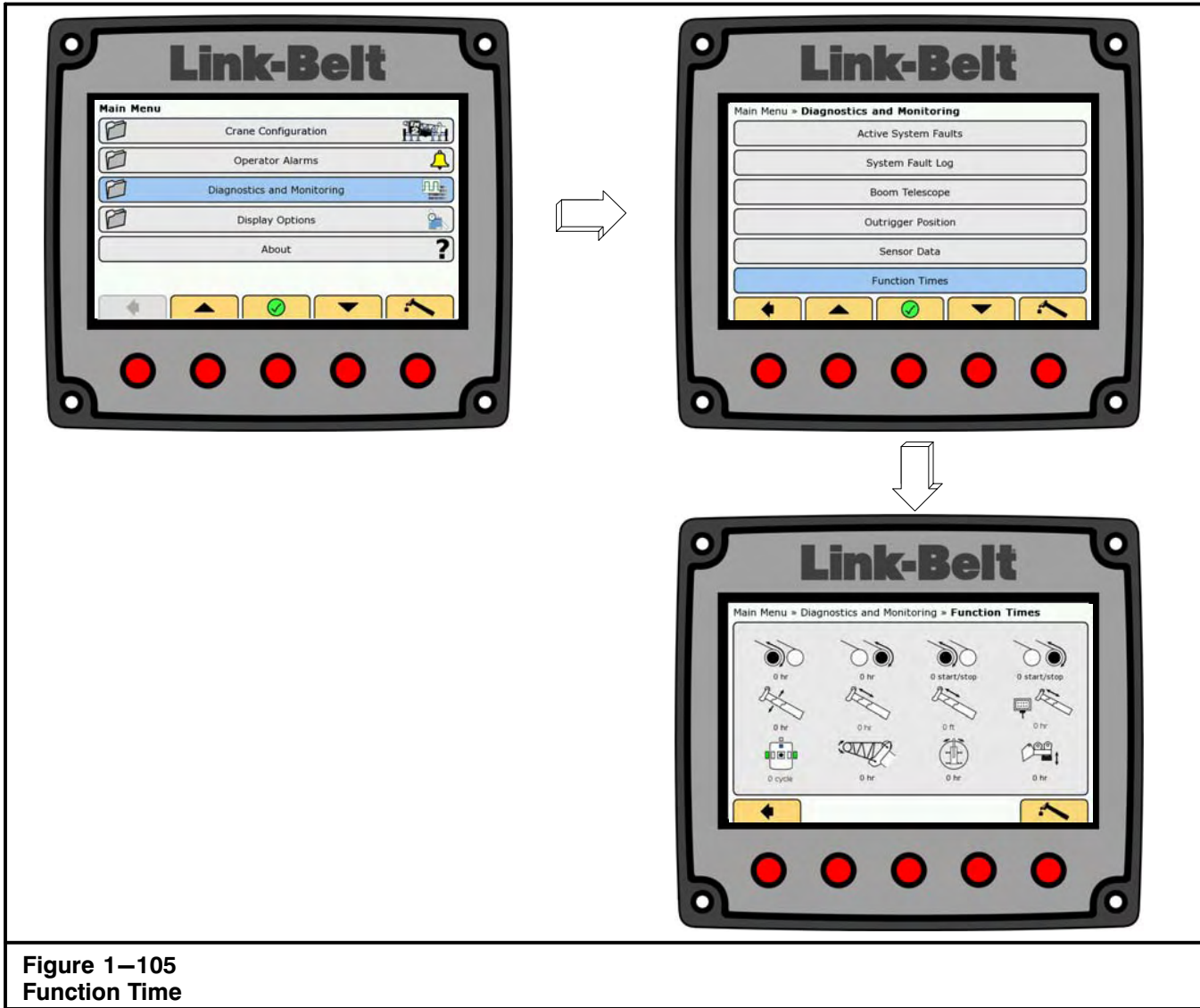







Figure 1–105
Function Time

Function Time Monitoring

The function time monitoring screen enables the operator to monitor the hours of use for the winch(s), boom hoist cylinder, and boom telescope cylinder for service purposes. The screen also displays the number of times the winch(s) has been started and stopped along with the total cumulative distance the boom has been extended and retracted.

1. From the normal working screen, press the Main Menu button .
2. Scroll to Diagnostics and Monitoring, and press the OK/Enter button .
3. Scroll to Function Time, and press the OK/Enter button . Refer to Figure 1–105.
4. From this screen, monitoring of the winch(s), boom hoist cylinder, and boom telescope cylinder can be done.
5. Press the back button  to return to the Diagnostics and Monitoring menu or press the Working Screen button  to return to the normal working screen.

Operator's Manual

Telematics

TELEMATICS - refers to the use of wireless devices and computer module technologies to transmit data in real time back to an organization.

This Link-Belt crane is equipped with one or more on-board computers that monitor and/or control the crane's performance. Crane owners may access electronic data by subscribing to the optional telematics feature offered by our telematics partner.

Specific electronic data transmitted by the onboard computers may be, but is not limited to, water temperature, oil temperature, engine rpm, fuel consumption, crane location, and other data that may be transmitted via satellite to our telematics partner. A crane owner may access this data by subscribing to the telematics feature through our telematics partner. A crane owner may then use some or all of the data transmitted from the crane's onboard computers to monitor the crane's activity, location, maintenance/service schedule, and/or other areas to assist them in managing this crane.

Note: Link-Belt recognizes that each individual crane's data transmitted via telematics is the property of the crane owner.









Data sharing is offered by Link-Belt through our telematics partner in an effort to provide Link-Belt distributors and our crane owners with overall enhanced product support through field troubleshooting, expedited parts procurement, infield repairs and other various support outlets. Any data shared by the crane owner is a "snapshot" of the data from the crane.

Link-Belt may request the crane owner "share data". The crane owner should determine who and when specific data related to their crane is shared. Link-Belt and its representatives may be in possession of specific crane data only when the crane owner selects "share data".

Shared data received by Link-Belt is not intended to be "stored" in any permanent data file at our factory. Shared data may exist at the factory location through the normal course of business until deleted by automatic expiration.

Link-Belt reserves the right to modify this policy as required and make every reasonable attempt to notify telematics subscribers of changes to this policy.

Transmitting Data

1. From the normal working screen, press the Main Menu button .
2. Scroll to Diagnostics and Monitoring, and press the OK/Enter button .
3. Scroll to Telematics, and press the OK/Enter button . Refer to Figure 1-106.
4. Scroll to the data that you would like to send, and press the OK/Enter button .
5. A confirmation screen will pop up. Press  to send the data or press  to cancel and return to the previous screen.
6. A  will be shown beside the data selected while the data is being sent. The Telematics Module will send data every 10 seconds for 10 minutes or until ignition is turned off.
7. Press the back button  to return to the Diagnostics and Monitoring menu or press the Working Screen button  to return to the normal working screen.

Operator's Manual

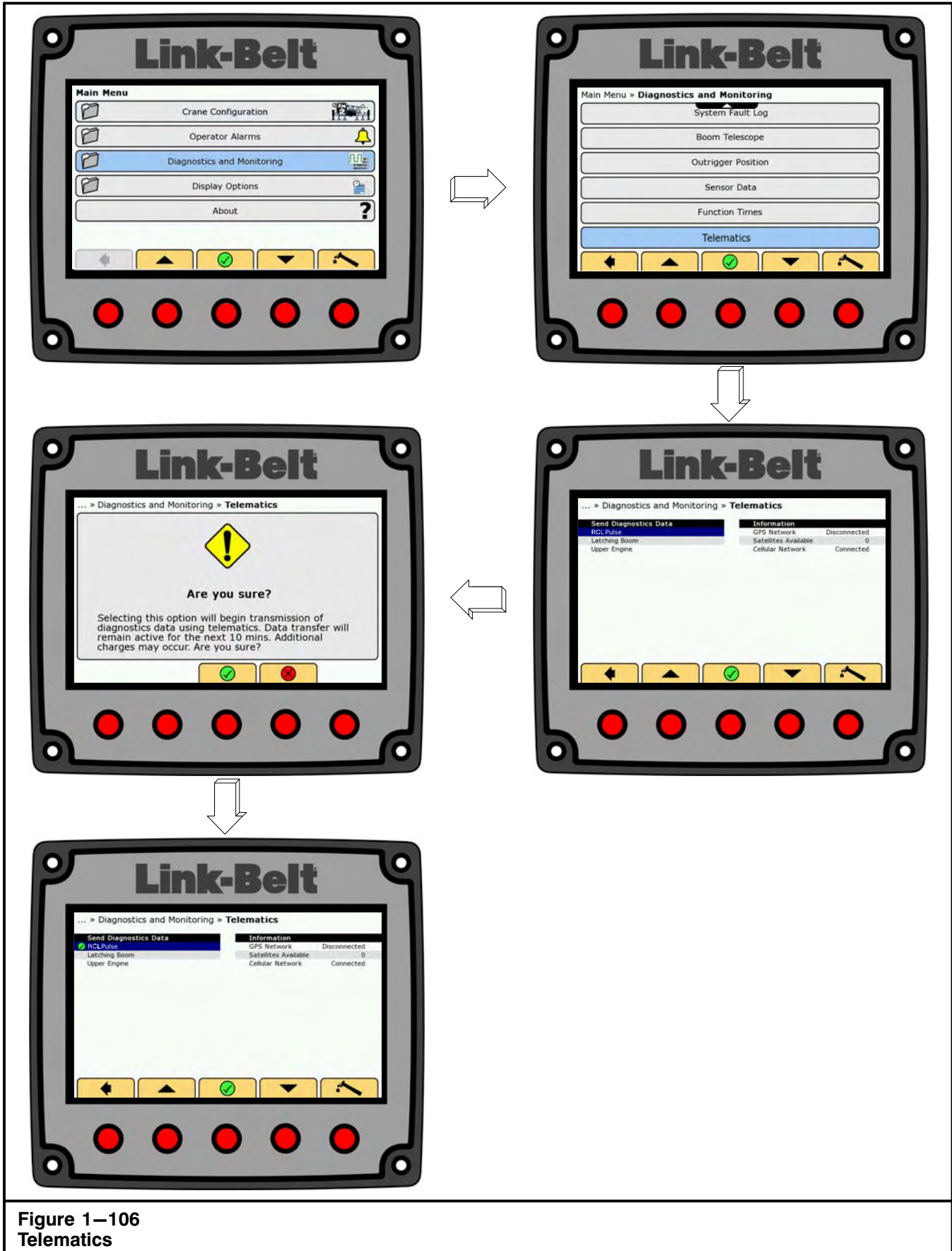
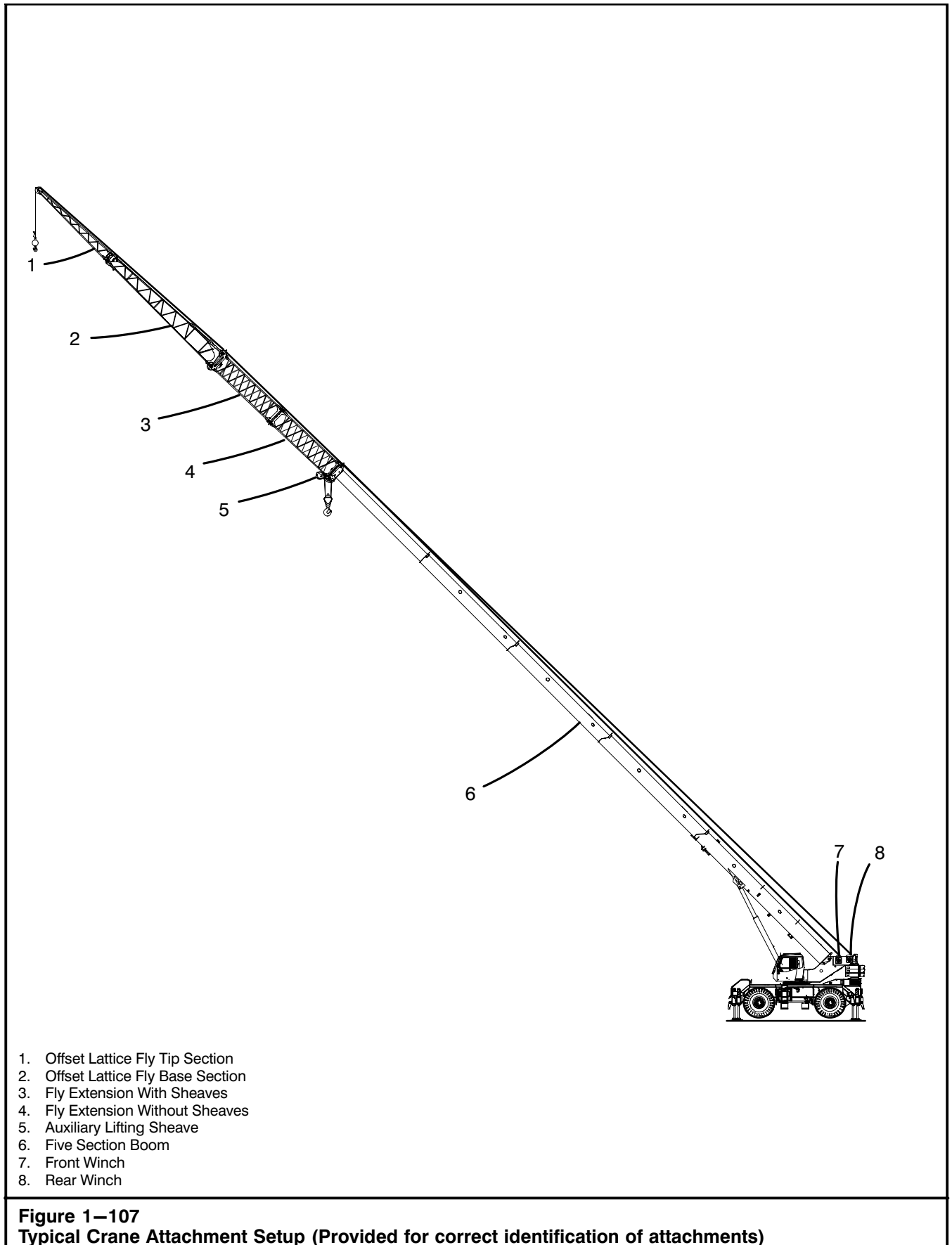
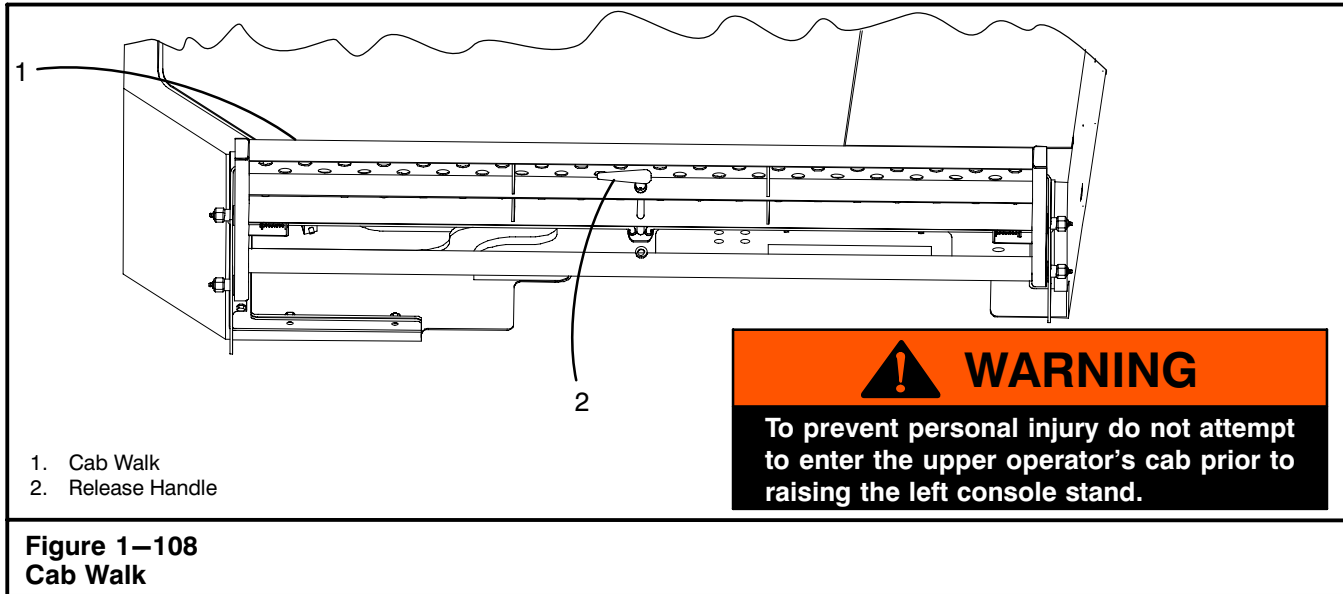

Figure 1-106
Telematics



Operator's Manual



Entering And Exiting The Upper Operator's Cab

Entering or exiting the upper operator's cab could be hazardous if certain aspects are not taken into consideration. The elevation of the carrier deck and upper operator's cab alone could cause serious injury if someone was to fall. For this reason ladders are mounted on each side of the carrier to provide easy access to the carrier deck and the upper operator's cab. A cab walk assembly is mounted under the upper operator's cab and should be extended when entering/exiting the cab. Refer to Figure 1–108. Turn the release handle to extend/retract the cab walk assembly. (Retract the upper cab walk anytime the crane is traveled or transported.) Numerous hand grips are also attached to the cab as well as non-skid safety strips on the surface of the carrier deck, to provide safe entry to the cab. Use these features to make climbing on the crane as safe as possible. Remain in three point contact with the crane at all times (two hands and one foot or two feet and one hand).

Another feature which is available to ease entry and exit of the upper operator's cab, is the adjustable operator's seat. (Refer to Figure 1–50). Move the seat back as required to allow safe entry. This feature also provides operator comfort during crane operation. Refer to "Operator's Seat" in this Section of this Operator's Manual for complete seat operating instructions.

Inside the cab, two separate features are provided to prevent accidental operation of the hydraulic controls while entering or exiting the operator's seat.

1. Function Lockout Switch

This switch is used to disable the hydraulic functions which are operated by the control levers

and boom telescope foot pedal. The switch is on the right side control console. Refer to Figure 1–39. Press the top part of the switch to disable hydraulic functions and to prevent inadvertent operation of these controls. To allow normal operation of the control levers and boom telescope foot pedal, press the bottom part of the function lockout switch. The bottom part of the switch will illuminate to indicate switch is in the "OPERATION" position. This switch must always be in the "DISABLE" position before entering or exiting the operator's seat.

2. Movable Left Side Console

The left side console is hinged at the rear to allow the operator to lift the console up, out of the way while entering or exiting the upper operator's cab. A spring assists lifting the console.

Lifting the left side console also performs the same duty as the function lockout switch, described above, disabling all hydraulic functions related to the control levers and boom telescope foot pedal. Lifting the left side console also automatically applies the swing park brake. Ensure the side console is lifted up, out of the way before attempting to enter or exit the upper operator's cab.

One more feature which is available to ease entry and exit of the upper cab, is the adjustable operator's seat. Lift the left hand arm rest up out of the way and move the seat and/or console back as required to allow safe entry. This feature also provides operator comfort during crane operation as well. Refer to "Operator's Seat" in this Section of the Operator's Manual for complete seat operating instructions.

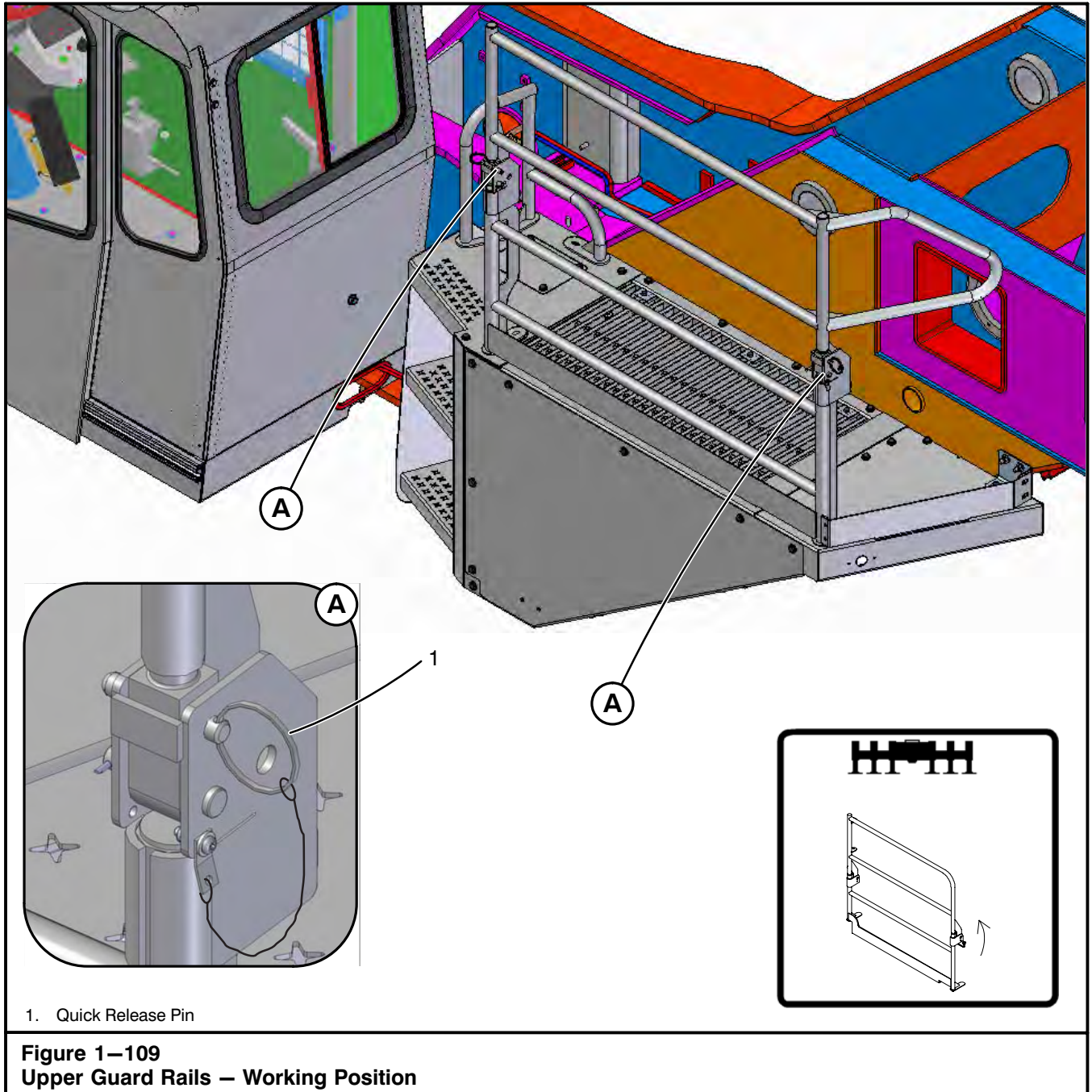

Upper Guard Rails

The crane is equipped with guard rails on the upper to make access to upper components safer when servicing the crane. The rails should remain in the working

position at all times except during highway travel and when lifting or transporting the crane. Refer to Figure 1–109. Position the rails in the storage/travel position before traveling the crane on the highway and when transporting the crane. Refer to Figure 1–110.

Operator's Manual

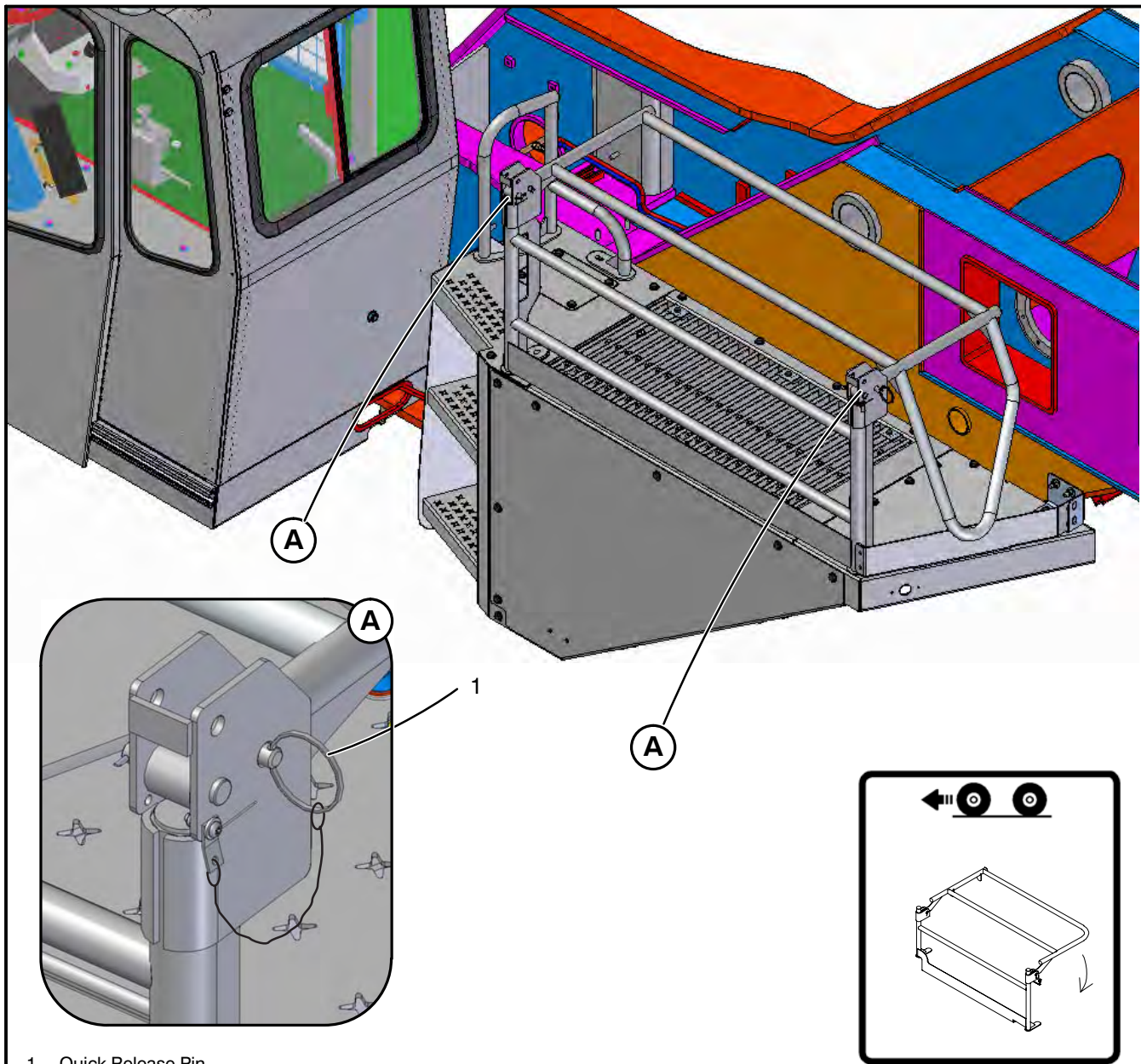

1. Quick Release Pin

Figure 1-110
Upper Guard Rails – Stored/Travel Position

Operator's Manual

Break-In Period

Operate a new crane at half throttle for the first twenty (20) hours of operation. A break-in period under moderate loads will assist in providing long, troublefree performance.

Before Starting Operations

Before starting daily operations, make the following checks and inspections:

Engine

Check fuel, oil, and cooling systems for proper fluid levels. Check for leaks. Repair or fill as required. Refer to engine manufacturer's manual for additional details.

Gear Cases

Visually inspect all gear cases for leaks or damage. If leaks or damage exist, repair and fill case to proper lubrication level.

Hydraulic System

Check all hoses for chafing, bulging, or other damage. Replace as necessary. Inspect hydraulic system for external leaks. Repair as needed. Check hydraulic reservoir oil level. Add oil if necessary.

Lubrication

Lubricate the crane as outlined in Section 2 of this Operator's Manual.

Note: Operators may have nothing to do with lubrication or maintenance of the crane, but it could be advantageous for them to be familiar with it. Knowledge of preventive maintenance makes the operator more aware of malfunctions in the crane so repairs can be made with a minimum of downtime.

Tires And Rims

Check tire inflation. Inflate to pressures per the Tire Inflation Label or the Tire Inflation Chart in the Crane Rating Manual. Check wheel lug nut torque, each day, for the first five (5) days of operation and every 100 hours of operation thereafter. Refer to Section 3 of this Operator's Manual for additional information on tires and rims.

Wire Rope And Sheaves

Inspect all wire rope and sheaves for damage or deterioration. Replace as necessary. Refer to Section 3 and Section 5 of this Operator's Manual for additional information on wire rope.

General Inspection

Visually inspect the entire crane for loose or missing cotter pins or bolts, or damaged fly chords or lattices. Check for oil or fluid leaks. Make repairs as needed.

Electrical System

Check the operation of all lights, windshield wipers, horns, turn signals, etc. Repair as needed.

Brakes

Start the engine and check park brake and service brake operations. Adjust or repair as needed.

Controls

Check all controls for proper operation and adjustment. Repair as needed.

Fire Extinguisher

A fire extinguisher is mounted in the operator's cab under the left console. Refer to Figure 1–50. It is an A B C type fire extinguisher, meaning it is capable of extinguishing most types of fires. The operator should be familiar with its location, the clamp mechanism used to secure it in place, and foremost the operation of the device. Specific instructions, regarding operation, are given on the label attached on the fire extinguisher. A charge indicator on the fire extinguisher monitors the pressure within the tank. Check the indicator daily to ensure the fire extinguisher is adequately charged and ready for use.

Carrier Suspension

Check that the oscillation suspension is properly adjusted and functioning normally. Refer to "Suspension Height Adjustment" in this Section of this Operator's Manual. During pick and carry operations and/or when traveling the crane, damage to the axles, cylinders, and other suspension components can occur if the oscillation suspension is not properly adjusted. Oscillation cylinders which are not properly adjusted can leave suspension components unprotected from shock loads which can lead to major crane damage.

Operator's Manual

Boom Distortion Due To Thermal Effects Of The Sun

The heat from the sun may have a thermal effect on the sides of telescopic booms causing the sides of the boom to expand (lengthen). The sides of the boom may not expand equally if the boom is extended for long periods of time with only one side of the boom exposed to the sun. The unequal expansion may cause boom distortion (the boom may “deflect” to one side). This is more noticeable with long boom lengths and/or long booms with long lattice flies attached to the boom.

For example, a 100 ft (30.5m) main boom, with a 50°F (10°C) temperature differential between the two sides of the boom, may cause the centerline of the main boom head to “deflect” as much as 3 ft (0.9m) off the centerline of the crane. Attaching a 50 ft (15.2m) lattice fly to the same boom may cause the centerline of the fly head to “deflect” as much as 10 ft (3.0m) off the centerline of the crane. This “deflection” to one side creates a “side load” on the boom and/or fly. Side load on a boom or fly, whether induced by the load or thermal effects, is dangerous and shall be avoided.

Prior to lifting any loads, inspect the boom or boom and fly combination to ensure they are straight. If the boom or boom and fly combination is not straight, ensure that all the boom wear pads are properly adjusted.

If the boom is distorted due to temperature differential on the sides of the boom, reposition the boom to allow the thermal effects from the sun to equalize the temperatures of the side walls of the boom to eliminate the distortion before lifting a load.

Engine Starting Procedure



WARNING

This manual must be thoroughly read and understood by the operator before starting the engine. Crane damage or personal injury could result from improper operating procedures.

Before attempting to start the engine, the operator should carefully read and understand the engine starting instructions in the engine manufacturer's manual and this Operator's Manual. Attempting to start or run the engine before studying these instructions may result in engine damage. The operator should learn and obey all applicable “Rules of the Road” and if not already a

competent driver, obtain instructions to attain these necessary skills. With the crane fully serviced and the operator familiar with all gauges, switches, controls, and having read and fully understood this entire manual, start the engine using the following procedures:

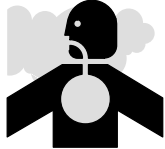
| | |
|---|---|
|  | <p>WARNING</p> <p>Diesel exhaust fumes can be harmful. Start and operate engine in a well ventilated area. If it is necessary to operate in an enclosed area, vent the exhaust to the outside. Properly maintain the exhaust system to its original design.</p> |
|---|---|

1. Walk around the crane to verify that there are no persons under, or in close proximity to the crane.
2. Check the cab to ensure that the transmission is in neutral and the park brake is engaged.
3. Sound the horn twice in succession, wait 10–15 seconds while making a visual check to verify that there are no persons under, or in close proximity to the crane.
4. In the cab, turn the ignition switch to the “On” position to energize the engine electrical system and allow the gauges to go through their self-test routine.
5. If required, allow the Wait To Start indicator light to go out.
6. Turn the ignition switch to the “Start” position. Release the ignition switch when the engine starts. If the engine fails to start in 30 seconds, release the ignition switch and allow the starter motor to cool a few minutes before trying to start the engine again. If the engine fails to start after four attempts, refer to the engine manufacturer's manual for instructions.
7. Warm Up – Run the engine at low throttle with no load while the engine is warming up. Observe the engine oil pressure gauge for proper indications. If there is no engine oil pressure after 10–15 seconds of running time, shutdown the engine immediately and repair the problem to avoid major upper engine damage. Refer to engine manufacturer's manual for proper oil pressure operating range.
8. When the engine has thoroughly warmed up, after all pressures and temperatures are within operating ranges, and all daily checks have been made, the crane is ready for operation.

Engine Shutdown Procedure

1. Lower any load to the ground and secure it properly.
2. Engage the swing park brake or travel swing lock as required.
3. Throttle the engine back to idle.
4. Allow the engine to idle 3 to 5 minutes to allow the engine to cool gradually and uniformly.
5. Turn the ignition switch to the "Off" position.
6. Remove the ignition keys from both the cab and lock the door if the crane is to be left unattended.

Cold Engine Starting

To help ignition in cold ambient conditions, air intake heater is used to warm the intake air prior to starting the engine. This improves combustion efficiency which aids in starting a cold engine. With the ignition switch in the on position, the ECM senses ambient air temperature then determines if the air intake must be energized to warm the intake air. A "Wait To Start" indicator light  on the Crane Control Display will illuminate to alert the operator not to crank the engine because the combustion chamber is too cold for fuel ignition. When the cylinders are warm enough to ignite the first charges of fuel, the indicator light will go out and the engine can be started.

 **DANGER**

Do not use starting fluids to aid in engine start up. This engine is equipped with a glow plug type cold starting aid and use of a starting fluid can cause an explosion resulting in serious personal injury or death.



Figure 1–111
Starting Fluid Warning Label

Operator's Manual

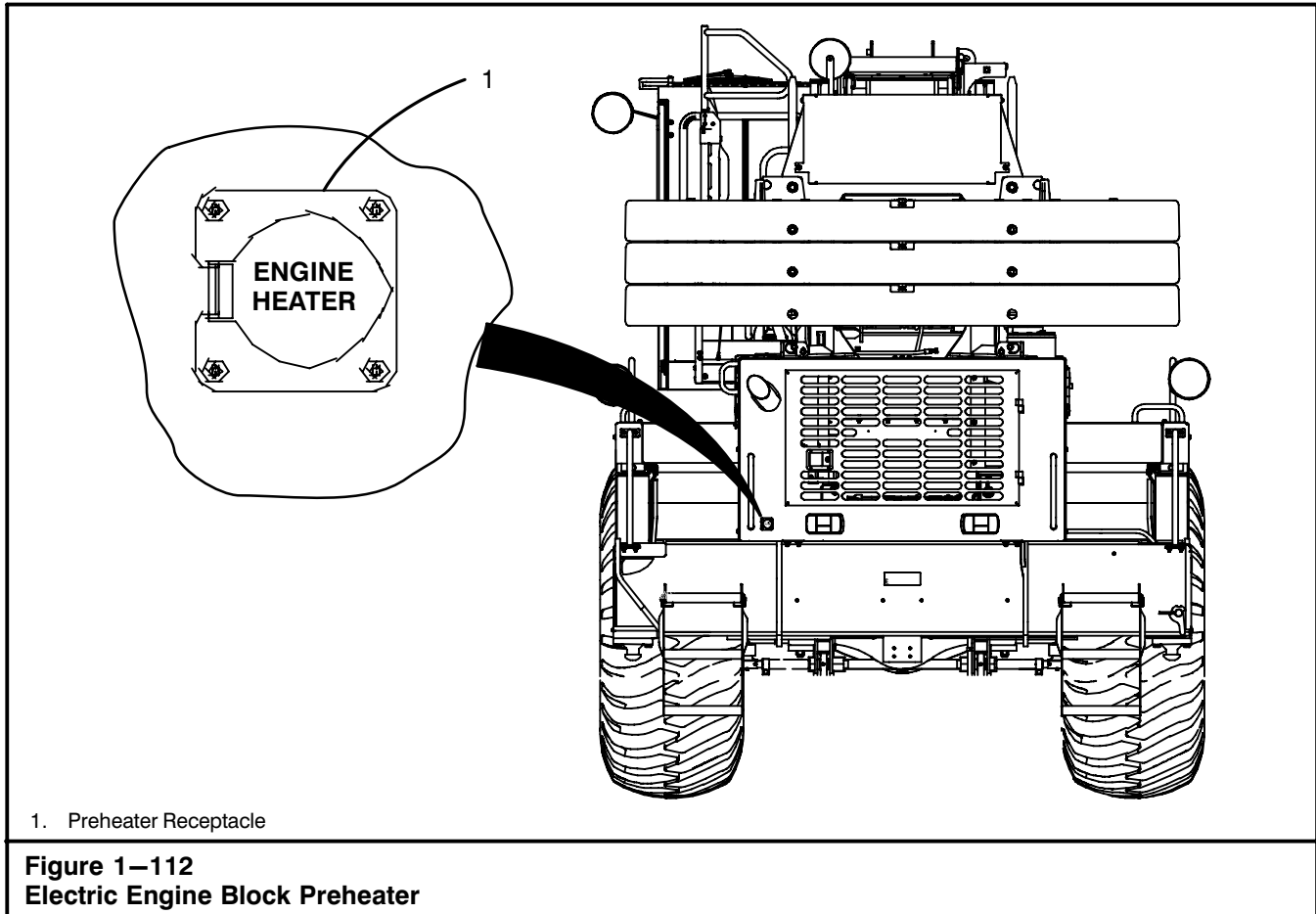

Electric Engine Block Preheater

The electric engine block preheater uses electrical power to heat the coolant and circulate it through the engine. The electric engine block preheater receptacle is on the rear of the carrier. Refer to Figure 1–112.

To Start The Electric Engine Block Preheater

1. Park the crane in suitable area for storage, engage the park brake, position the transmission shifter to neutral, and shutdown the engine.



WARNING

Areas adjacent to the preheater must be clean and free of oil and debris to avoid possible fire hazard.

2. Plug an approved extension chord into the receptacle on the rear of the carrier. Plug the other end into a 110V to 120V electrical source.

Note: Unplug the engine block preheater before starting the engine.

To Stop Electric Engine Block Preheater

1. Unplug preheater cord from electrical source and the receptacle on the rear of the carrier.
2. Properly store the extension cord.

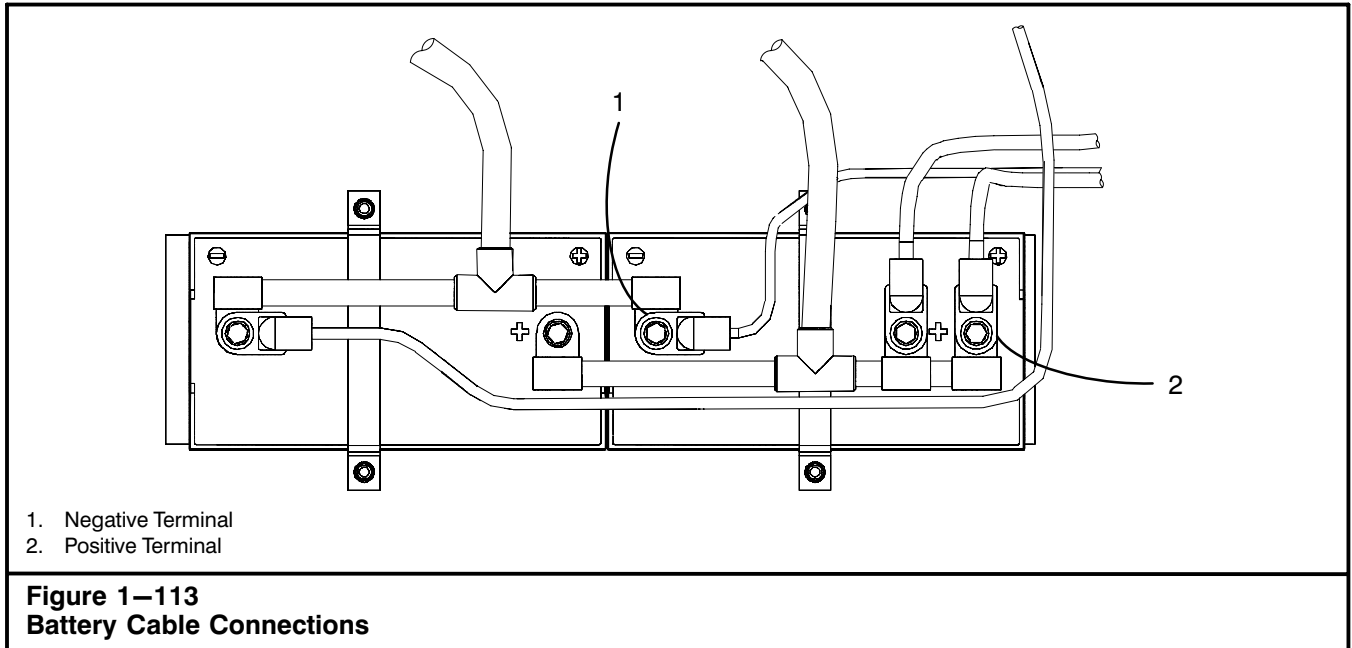

Jump Starting The Crane

The crane has two (2) 12V batteries mounted in the battery box at the rear of the crane.



WARNING

To avoid serious personal injury and/or major equipment damage, follow these procedures in the order they are given.



WARNING

Battery posts, terminals, and related accessories contain lead and lead compounds. Wash hands after handling.

Wear protective clothing and shield your face and eyes when working around batteries. Batteries contain sulfuric acid which burns skin, eyes, and clothing.

Do not jump start a damaged battery. Ensure vent caps are tight and level. If another vehicle is used, ensure booster vehicle and crane are not touching.

The gases around the battery can explode if exposed to open flames or sparks. An explosion could result in serious personal injury and/or major equipment damage.

1. Check all battery terminals and remove any corrosion before attaching jumper cables.
2. Connect one end of the first jumper cable to the 12V positive (+) terminal of the discharged battery.
3. Connect the other end of the first cable to the 12V positive (+) terminal of the 12V power source or booster battery.
4. Connect one end of the second jumper cable to the negative (–) terminal of the 12V power source or booster battery.
5. Connect the other end of the second cable to a ground location on the carrier frame as far away from crane batteries as possible.
6. If another vehicle is used to jump start the crane, start the booster vehicle. Ensure booster vehicle and crane are not touching. Run the booster vehicle's engine at a moderate speed.
7. Start the disabled crane. After the crane is started, remove jumper cables in reverse order.
8. Let the crane's engine run for a few minutes to charge the discharged batteries.
9. Check the battery gauge in the operator's cab. The gauge reading should be increasing toward 14 volts.

Note: If the batteries are at very low charge, voltage may increase slowly. If voltage does not increase, replace the batteries and/or check the electrical system.

Operator's Manual

Crane Operation

Cranes are used primarily for making heavy lifts. In order to do this properly, certain procedures must be followed. The following is a suggested procedure for making typical lifts:

Note: Before operating the crane near airports, radio and microwave towers, power lines, etc., always refer to and comply with all local, state, and federal laws.

1. Determine the weight to be lifted. Add the weight of the hook block and/or hook ball, slings, rigging, fly, etc. Determine height to which the load must be lifted.
2. Refer to the capacity chart, Working Areas and Working Range charts in the Crane Rating Manual in the operator's cab. Find the shortest boom length and load radius that will accomplish the job.
3. Position the crane so a minimum swing is necessary. Do not swing the upper over areas not covered on the capacity chart in the Crane Rating Manual, as the crane could tip, even without a load on the hook in these areas.
4. The crane must be supported by a firm, solid level surface before starting to lift. All capacities in the Crane Rating Manual are based on the crane being level in all directions. If the crane is not level, out swing or side swing of the load will greatly reduce lifting capacities and could cause crane damage or an accident. If the ground is soft, use mats.
5. If outriggers are used, the following points must be observed:
 - a. The outrigger beams must all be equally extended (all fully retracted, intermediate extended, or fully extended) to lift the loads shown in the Crane Rating Manual. Major reductions in lifting capacity will result if beams are not in the same position and this could lead to major crane damage or an serious accident.
 - b. Outrigger pontoons must be on solid, smooth footing, flush with the ground (no hills, or valleys under pontoons), otherwise pontoons may be damaged or destroyed. If there is any doubt, use mats.
 - c. All capacities listed for the crane on outriggers are based on the outrigger jacks being used to raise the crane so that all tires are clear of the ground and the crane is level. A bubble level is provided in the operator's cab to assist the operator in leveling the crane.
6. When making lifts on tires, the following points must be observed:
 - a. All tires must be inflated to pressures as listed on the Tire Inflation Label or the Tire Inflation Chart in the Crane Rating Manual.
 - b. On tire lifts are to be made from the main boom only. Do not use the auxiliary lifting sheave or fly.
 - c. Lifts while on tires must be from firm level surface. Use mats and/or grade the supporting surface as required to ensure safe lift.
7. Raise the boom and swing over the load. Extend the boom to the desired length.
8. Lower the hook block and/or hook ball and fasten it onto the load. The following points must be observed:
 - a. The boom peak must be directly above the load. Booms are made to lift, and must never be used to drag a load sideways.
 - b. Always use chains, wire ropes, or slings of ample size and make periodic checks of their condition.
 - c. Always use sufficient parts of line. Refer to Wire Rope Capacity chart in the Crane Rating Manual in the operator's cab for the number of parts of line needed for a given lift.
 - d. When lifting loads, care should be taken to prevent sudden loading or unloading of the winch wire rope. Ease into the load. Lift the load a few inches (*centimeters*) off the ground and hold to check the winch brakes.
9. Lift the load to the desired height. Boom to the desired angle. Be careful when booming down or extending the boom, as these increase the load radius and result in a decrease in capacity. Ensure the load being lifted remains within the lifting capacity of the crane at the boom length and radius being used.
10. Control the load at all times. Use hand lines to guide the load. Do not guide loads into place with your hands. Swing slowly and smoothly. Avoid jerks when starting or stopping swings.
11. If the crane is to travel with a suspended load, refer to "Pick And Carry Operation" in this Section of this Operator's Manual for further instructions.

During Operation

The operator must remain alert to possible malfunctioning of the crane while operating. If the crane does malfunction, lower the load and shutdown the crane until the problem is found and corrected. During operation, the operator must:

1. Remain alert to any noise, loss of power, or bad response to control of the crane. Watch the engine oil pressure and coolant temperature gauges for proper operating ranges.

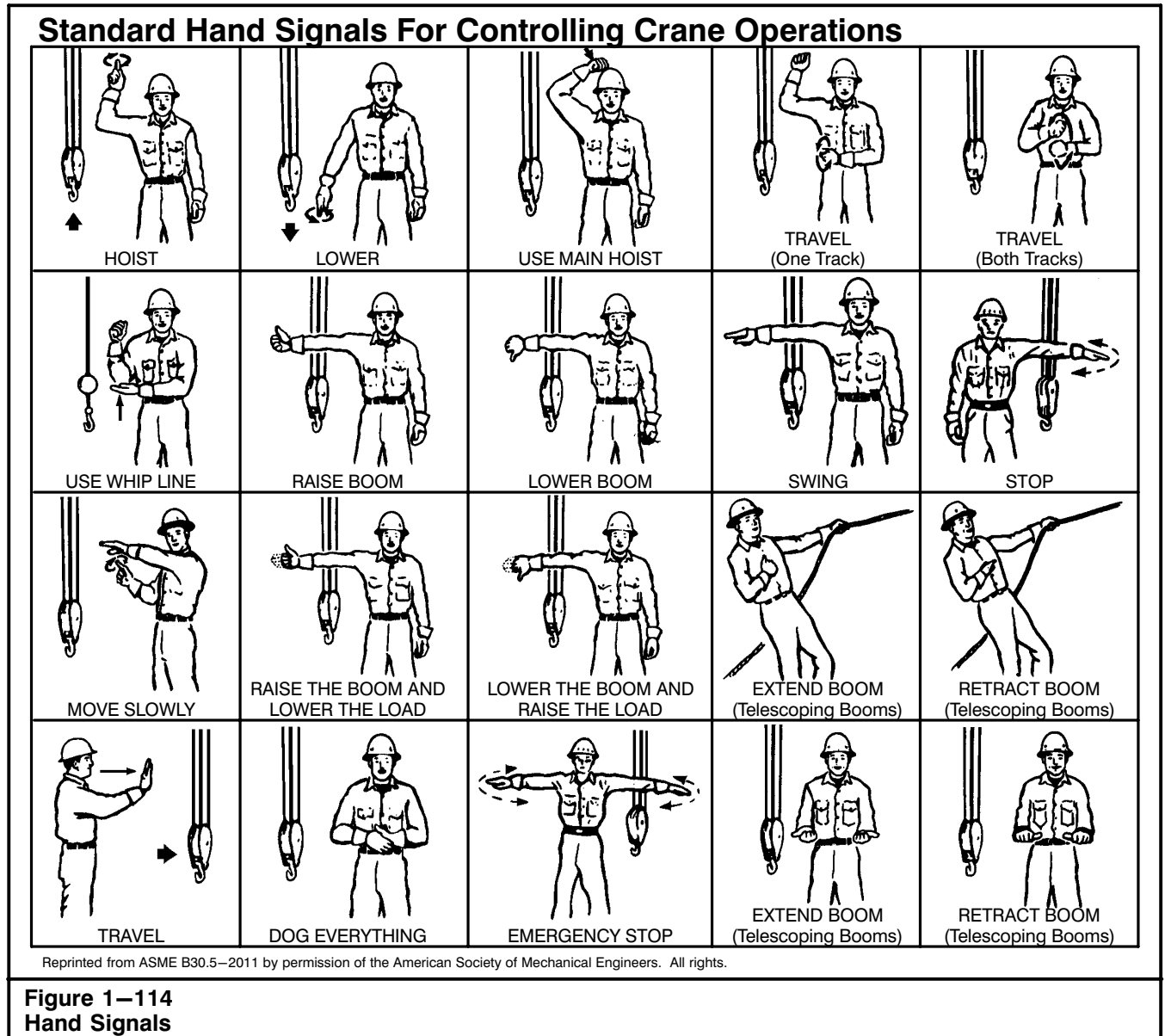

2. Watch the hydraulic system oil temperature gauge. If the temperature exceeds maximum temperature, shutdown the crane until the problem is corrected. (Refer to Section 2 of this Operator's Manual for the maximum temperature for each viscosity of hydraulic oil.)
3. Listen for any unusual noises in the hydraulic system, power train, gear boxes. If any, correct problem.
4. Watch for oil leaks or any loss of control. If any develop, correct before continuing operation.
5. Ensure all controls work freely and easily, with no sticking or binding. Lubricate or adjust as necessary.
6. If working on outriggers, periodically check the outriggers to ensure the crane is level and stable. If working on tires, ensure the tires are inflated to the proper pressure. (Refer to the Tire Inflation Label or the Tire Inflation Chart in the Crane Rating Manual for proper tire pressure.)
7. Heed all DANGER, WARNING, and CAUTION labels. Observe good safety practices at all times.

Operator's Manual

Hand Signals

Hand Signals are important for communications between the designated signal person and the operator. A Hand Signals Chart, Figure 1–114, is included in this Section of this Operator's Manual. A copy is also on the right side window in the operator's cab.

These signals should be used at all times unless voice instructions with a radio or telephone are being used. One person should be designated as a signal person and their signals obeyed by the operator. Obey a stop signal from anyone.

Pick And Carry Operation

Travel during pick and carry operations is restricted to speeds of 2.5 mph (*4km/h*) or less, and creep, on a firm, level surface. Creep is defined as crane movement limited to 200 ft (*61m*) in a 30 minute period and not to exceed 1mph (*1.6km/h*) maximum speed. Lifts are to be made off the main boom only, with the crane prepared as follows:

1. Ensure that the suspension has been adjusted to the proper travel height. Refer to "Suspension Height Adjustment" in this Section of this Operator's Manual.
2. Inflate the tires to the required pressure listed on the Tire Inflation Label or the Tire Inflation Chart in the Crane Rating Manual.
3. Do not exceed On Tires, Pick And Carry capacities. Refer to Creep or 2.5 mph (*4km/h*) capacity charts in the Crane Rating Manual.
4. Level the crane on fully extended outriggers with the tires clear of the ground.
5. Position upper over front of the carrier and engage the travel swing lock. Release the swing park brake and the 360° swing lock if equipped.
6. Boom must be extended in accordance with boom mode EM1.
7. Properly store the fly base and tip, if equipped.
8. Retract all outrigger jacks just clear of the ground but leave the outrigger beams fully extended.
9. Attach as many hand lines as necessary to prevent the load from swinging during travel.
10. Carefully attach the load to the winch wire rope and lift it only as high as necessary.
11. Carefully travel at no more than 2.5 mph (*4km/h*) depending on chart selection. Take extra care due to the increased overall width caused by the extended outrigger beams. The outriggers or pontoons must not be allowed to hit any obstructions. Maintain a safe distance from all personnel and obstructions. Travel only on a firm, level surface.
12. Once the desired destination is reached, shift the transmission to neutral and apply the park brake.

CAUTION

Do not leave the swing park brake or 360° swing lock, if equipped, in the engaged position during pick and carry operations. Failure to release these devices during this operation may result in damage to the swing speed reducer.

Job Site Travel, No Load Upper Over The Front, Boom Retracted 2.5 MPH (4.0km/h) Maximum

| Counterweight (lb) Installed on Upper | Maximum Boom Angle (°) | | | |
|--|------------------------|----------------------------------|----------------------------------|-------------------------------------|
| | 35–58 Ft Fly Stored | 35 Ft Fly Erected (2° Offset) | 58 Ft Fly Erected (2° Offset) | 74–90 Ft Fly Erected (2° Offset) |
| 0 | 45 | 45 | 45 | PROHIBITED |
| 9,600 | 45 | 45 | 45 | PROHIBITED |
| 19,200 | 45 | 45 | 45 | PROHIBITED |
| 28,800 | 40 | 40 | 40 | PROHIBITED |

Traveling The Crane

Certain conditions must be met for safe travel. Refer to the following procedures before traveling the crane.



WARNING

Do not use 4-wheel, crab, or rear wheel steer mode for extended or high speed travel as steering behavior may be unfamiliar and a loss of crane control could occur.

Do not travel with upper over the side. Position upper over the front and engage the travel swing lock. Crane may tip over causing personal injury and/or crane damage.

Job Site Travel

Job site travel is limited to speeds less than 2.5 mph (4km/h). The crane may be traveled on the job site with no load per the following procedure:

1. Ensure that the suspension has been adjusted to the proper travel height. Refer to "Suspension Height Adjustment" in this Section of this Operator's Manual.
2. Inflate the tires to pressure listed on the Tire Inflation Label or the Tire Inflation Chart in Crane Rating Manual for 2.5 mph (4km/h) maximum speed.
3. Level the crane on fully extended outriggers.
4. If traveling on a firm, smooth, and level surface, position the upper and attachments according to the "Job Site Travel" chart in this Section of this Operator's Manual. Do not move the boom during travel.
5. If traveling on a slope, travel directly up or down the slope. Position the upper over the front of the carrier with the boom fully retracted and at 0°. The fly base and tip stored.
6. Engage the travel swing lock. Release the swing park brake and the 360° swing lock if equipped.

CAUTION

Do not leave the swing park brake or 360° swing lock, if equipped, in the engaged position during pick and carry operations. Failure to release these devices during this operation may result in damage to the swing speed reducer.

7. Fully retract all outrigger jacks and beams.

CAUTION

When the hoist line is tied off to the crane or any solid object, do not extend the boom, raise or lower the boom, or raise the crane on outriggers. The winch system could be overloaded causing major winch or crane damage.

8. Secure hook block and/or hook ball to prevent excessive swinging.
9. Carefully travel at no more than 2.5 mph (4km/h). Maintain a safe distance from all obstructions, structures, and power lines.
10. Once the desired destination is reached, shift the transmission to neutral and apply the park brake.

Operator's Manual

CAUTION

Do not exceed 5 mph travel speed with counterweight configurations of 0 lb. & 28,800 lb. Failure to comply with this limitation may result in crane damage.

| TRAVEL SPEEDS | |
|----------------------|-----------------|
| GEAR | MAX SPEED (MPH) |
| 2-WHEEL DRIVE | |
| 1 | 4.0 |
| 2 | 8.1 |
| 3 | 19.8 |
| 4-WHEEL DRIVE | |
| 1 | 1.4 |
| 2 | 2.9 |
| 3 | 7.6 |

**Figure 1–115
Travel Speed Limitation Label**

Highway Travel

Highway travel is considered to be any travel of the crane over 2.5 mph (4km/h). The following conditions and precautions must be met for any highway travel.

1. If equipped, the fly base and tip must be secured in the stored position on boom.
2. The boom must be over the front of the crane with the travel swing lock engaged. Release the swing park brake and the 360° swing lock if equipped.

CAUTION

Do not leave the swing park brake or 360° swing lock, if equipped, in the engaged position during pick and carry operations. Failure to release these devices during this operation may result in damage to the swing speed reducer.

3. All boom sections must be fully retracted with the boom at 0°. Secure the hook block and/or hook ball to prevent excessive swinging.

CAUTION

When the hoist line is tied off to the crane or any solid object, do not extend the boom, raise or lower the boom, or raise the crane on outriggers. The winch system could be overloaded causing major winch or crane damage.

4. All outriggers must be fully retracted (jacks and beams) with all pontoons removed from jacks and stored properly.
5. The drive train must be set to 2-Wheel drive and the steering selection switch in the conventional steer mode.
6. Disengage the main hydraulic pump if equipped.
7. Ensure that the suspension has been adjusted to the proper travel height. Refer to "Suspension Height Adjustment" in this Section of this Operator's Manual.
8. Fold the guard rails in the stored/travel position.
9. Retract the upper cab walk to its stored position.
10. Check all tires for correct pressure, adjust if required. Refer to the Tire Inflation Label or the Tire Inflation Chart in the Crane Rating Manual.
11. During highway travel there must be at least a 30 minute rest period for every 50 miles (80km) of driving or 2 hours of sustained operation whichever occurs first and a 60 minute rest period after 4 hours of operation.
12. Obey all "Rules of the Road" and travel carefully.

Operator's Manual

Counterweight Removal And Installation (If Equipped)

Access to certain job sites may require the crane to be transported on roads with strict vehicle load limitations. In order to meet such limitations, the counterweight can be removed and transported separately. If the crane is equipped with maximum counterweight, removing the counterweight can reduce the weight of the crane by as much as 28,800 lb (13 064kg).



WARNING

When operating the crane with no counterweight, always refer to the Crane Rating Manual to ensure lifting capacities are not exceeded.

Counterweight Removal

1. Park the crane on a firm level surface, engage the park brake, and shift the transmission to neutral.
2. Properly level the crane on fully extended outriggers with all tires clear of the ground.
3. Fully retract all boom sections. If equipped, properly store the fly on the boom.
4. Swing the upper over the front of the carrier. Engage the travel swing lock and boom up to 63°.
5. Attach the remote control box to the electrical connector on the left rear of the upper frame. Refer to Figure 1–116.

Note: If only one counterweight slab is installed on the upper, place the single counterweight removal bracket in the “Up” position.



WARNING

To avoid personal injury, do not place any body part under counterweight during lowering or raising of the counterweights.

6. Remove the lock pins and pins which secure the counterweight to the upper frame.

Note: Counterweight cylinders may have to be raised (retracted) to relieve pressure on the pins to ease removal.

CAUTION

Do not fully extend the counterweight removal cylinders allowing them to push down on the counterweights. Damage to the engine hood may occur. Extend the cylinder just enough to allow the counterweights to rest on the removal brackets.

7. Push the DOWN button on the remote control box to lower (extend) the counterweight to the counterweight removal brackets.
8. Remove the lock pins and pins which secure the counterweight to the counterweight removal cylinders.

Note: If all counterweights are not to be removed, remove only the two counterweight connecting pins above the counterweight(s) to be removed.

9. Push the UP button on the remote control box to raise (retract) the cylinders away from counterweight.

Note: The counterweight slabs weigh 9,600 lb (4 355kg) each.

10. Swing the upper over the rear of the carrier. Attach a sling to the counterweight using the lifting bars in the counterweight.
11. Attach other end of sling to the crane's hook block.



WARNING

When operating the crane with no counterweight, always refer to the Crane Rating Manual to ensure lifting capacities are not exceeded.

Do not travel or transport the crane with the counterweight positioned on the removal brackets. Counterweight may fall causing serious personal injury and/or major crane damage.

12. Lift counterweight off removal brackets and onto transport vehicle.

Operator's Manual

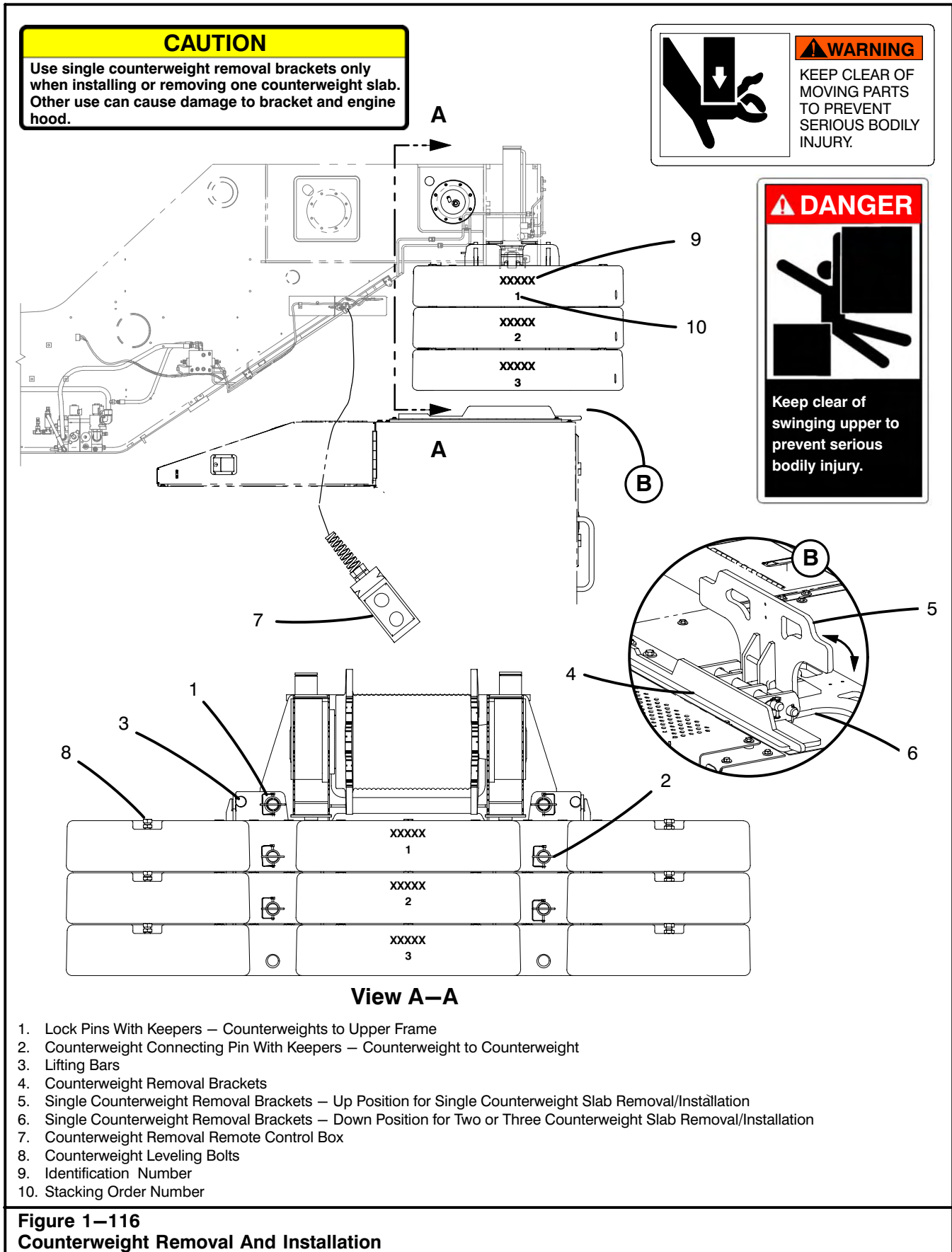

Operator's Manual

Counterweight Installation

1. Park the crane on a firm level surface, engage the park brake, shift the transmission to neutral.
2. Properly level the crane on fully extended outriggers with all tires clear of the ground.

Note: The counterweights are stamped with an identification number and stacking order number as illustrated in Figure 1–116. When installing counterweights, ensure the counterweights are stacked in sequential order from the top down beginning with “1”.

3. Attach a sling to the counterweight using the lifting bars on the counterweight. Refer to Figure 1–116.

Note: If only one counterweight slab is to be installed on the upper, place the single counterweight removal bracket in the “Up” position. If two or more slabs are to be installed, ensure the brackets are in the “Down” position.

Note: The counterweight slabs weigh 9,600 lb (4 355kg) each.

4. Using the crane, pick the counterweight off the transport vehicle.

**WARNING**

When operating the crane with no counterweight, always refer to the Crane Rating Manual to ensure lifting capacities are not exceeded.

5. Swing the upper over the rear of the carrier. Engage the travel swing lock. Set the counterweight on the removal brackets. Ensure counterweight is balanced on the removal brackets.

**WARNING**

Counterweight must be balanced on the removal brackets. Counterweight may fall causing personal injury and/or crane damage.

6. Swing the upper over the front of the carrier and engage the travel swing lock.

CAUTION

Do not fully extend the counterweight removal cylinders allowing them to push down on the counterweights. Damage to the engine hood may occur. Extend the cylinder just enough to align with the counterweights connecting lugs.

7. Push the DOWN button on the remote control box to lower (extend) the counterweight removal cylinders to align connecting lugs on the counterweight.
8. Install the pins and lock pins to secure the counterweight to the counterweight removal cylinders.
9. Push the UP button on the remote control box to raise (retract) the cylinders and lift the counterweight.

**WARNING**

To avoid personal injury, do not place any body part under counterweight during lowering or raising of the counterweights.

10. Continue to lift counterweight until the lugs on the counterweight align with the lugs on the upper frame.
11. Install the pins and lock pins which secure the counterweight to the upper frame.
12. Lower (extend) cylinders slightly to transfer the weight of the counterweight from the cylinders to the upper frame.
13. Adjust the counterweight leveling bolts so that the counterweights hang level and do not sway. Do not tighten the leveling bolt to the point that the counterweight pins cannot be easily removed.

Operator's Manual

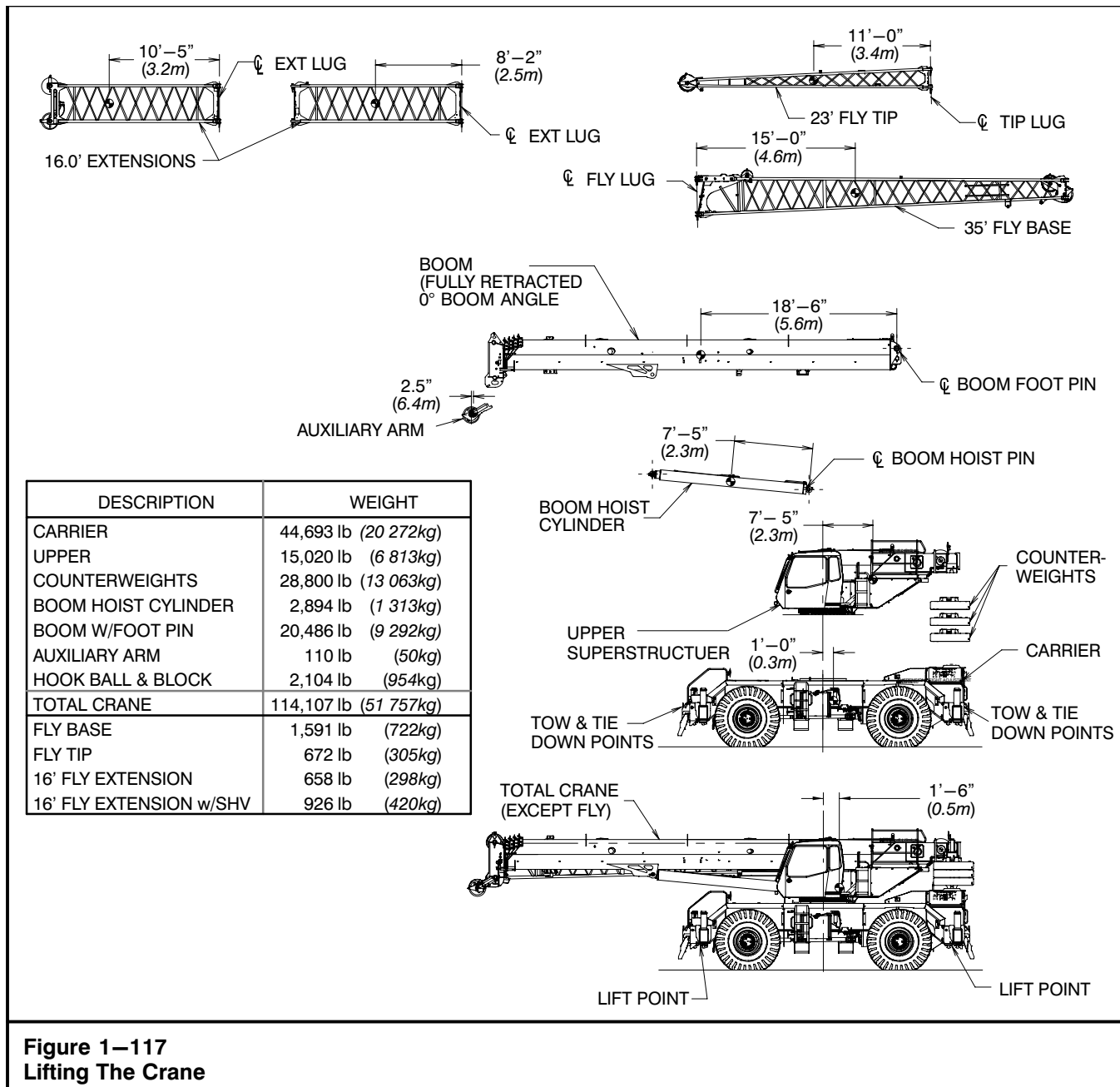

Figure 1-117
Lifting The Crane

Lifting The Crane

The entire crane (except the fly) can be lifted or the components may be removed from the crane and lifted individually. Refer to Figure 1-117 for the center of gravity (CG) and weights for the entire crane and the individual components. The following conditions and precautions must be met before lifting the crane or removing any component.

1. The crane must be parked on a firm level surface with the travel swing lock engaged. The swing park brake and 360° swing lock, if equipped, must be released.
2. Use lifting equipment, shackles, slings, chains, etc. of suitable size and strength. All lifting equipment must be inspected before lifting the crane. The inspection must be recorded and dated in accordance with current OSHA regulations.
3. Do not lift crane with fly attached to boom. Damage to the fly may result. Remove the fly from the crane before lifting. Refer to Section 4 of this Operator's Manual for the correct procedures for removing the fly.
4. Fold the guard rails in the stored/travel position.
5. When lifting the entire crane (without fly), extend the outrigger beams to the intermediate position.

Operator's Manual

and install slings around the beams. Protect slings from any sharp edges.

6. The weights and locations of all CG's include all possible options (heaviest crane) except the fly base and fly tip. Use the CG's as a starting point. Center hoist line on the CG, lift a few inches (*centimeters*) and adjust the hoist line to keep the crane/component(s) level at all times.
7. Removal of any component(s) from the crane will shift the CG of the entire crane. Adjust hoist line to account for the removal of any component(s).
8. Use only properly attached nylon straps to lift fly base or fly tip to prevent damage to the component. Refer to Figure 1–11. Protect the straps from sharp edges.
9. Do not allow the hoist lines to contact boom while lifting crane. Damage to the boom may result.

Towing The Crane

Always use good judgment and reliable equipment when towing the crane. Use extra caution when towing the crane on the highway and in traffic. When making connections between the crane and towing vehicle, ensure none of the connections will cause damage to either vehicle. Pay particular attention to tie rods, brake lines, power steering cylinders, and power steering lines. The tow lugs are the recommended connection points on the crane.

Note: Due to difficulty in steering the crane, towing should be limited to short distances.

Always exercise safety and follow all local codes when towing the crane. Prepare the crane as follows before towing it.

1. If equipped, store the fly base and tip on the boom.
2. The boom must be over the front of the crane with the travel swing lock engaged. Release the swing park brake and the 360° swing lock if equipped.

CAUTION

Do not leave the swing park brake or 360° swing lock, if equipped, in the engaged position during towing operations. Failure to release these devices during this operation may result in damage to the swing speed reducer.

3. All boom sections must be fully retracted with the boom at a 0° angle. Secure the hook block and/or hook ball to prevent excessive swinging.

CAUTION

When the hoist line is tied off to the crane or any solid object, do not extend the boom, raise or lower the boom, or raise the crane on outriggers. The winch system could be overloaded causing major winch or crane damage.

4. All outriggers must be fully retracted (jacks and beams) with all pontoons removed from jacks and stored properly.
5. All control levers in the operator's cab must be in the neutral position.
6. Shift the transmission to neutral and engage the 2-Wheel Drive mode. Remove the drive tube between the transmission and axle or lift the rear driving wheels.

CAUTION

Failure to disconnect the drive tube, or lift the driving wheels, before pushing or towing the crane can cause major transmission damage.

7. Unlock the steering column by turning the ignition switch to the "On" position. Turn on the hazard flashers.
8. Release the park brake when the crane is attached to the towing vehicle and ready to be towed.

Operator's Manual

Transporting The Crane

When transporting the crane, precautions should be taken in securing the crane to the trailer, barge, or other means of conveyance. The tow lugs are the recommended tie down points. If the tow lugs cannot be used to tie the crane down, chains may be looped around the outrigger boxes or the axle housings to secure the crane down.

CAUTION

If chains are wrapped around the axle housing, be certain the chains will not damage the tie rods, brake lines, power steering cylinders, or power steering lines.

If chains are wrapped around the outrigger box collar, be certain the chains will not damage the hydraulic lines and fittings. The chains should be wrapped around the outrigger box, not the outrigger beam.

Always exercise safety and follow all local codes when loading, unloading, or transporting the crane.

Prepare the crane as follows before transporting it:

1. If equipped, store the fly base and tip on boom.
2. The boom must be over the front of the carrier with the travel swing lock engaged. Release the swing park brake and 360° swing lock if equipped.

CAUTION

Do not leave the swing park brake or 360° swing lock, if equipped, in the engaged position while transporting the crane. Failure to release these devices during this operation may result in damage to the swing speed reducer.

3. All boom sections must be fully retracted with the boom at a 0° angle. Secure the hook block and/or hook ball to prevent excessive swinging.

CAUTION

When the hoist line is tied off to the crane or any solid object, do not extend the boom, raise or lower the boom, or raise the crane on outriggers. The winch system could be overloaded causing major winch or crane damage.

4. All outriggers must be fully retracted (jacks and beams) with all pontoons removed from jacks and stored properly.
5. Engage the park brake and shift the transmission to neutral.
6. If transport height adjustment is required, refer to "Suspension Height Adjustment" in this Section of this Operator's Manual.
7. All control levers in the operator's cab must be in the neutral position.
8. Securely cover the exhaust to prevent air being forced into the exhaust. Covering the exhaust will also help prevent any water or other contamination from entering the exhaust which could also damage the turbocharger.

CAUTION

When a turbocharged engine is not running, air forced into the exhaust will cause the turbocharger impeller to spin. Without the engine running, the turbocharger bearing is not lubricated. When transporting the crane and the exhaust is facing in a direction such that the travel speed continually forces air into the exhaust, it may cause major damage to, or total destruction of the turbocharger.

9. Shutdown the engine and remove the keys from the crane. Lock all windows and doors.
10. Fold the guard rails in the stored/travel position.
11. Retract the upper cab walk to its stored position.
12. Depending on the specific situations, further preparations may be needed to protect the crane from the environment or vandalism. Refer to "Crane Storage" for further suggestions.

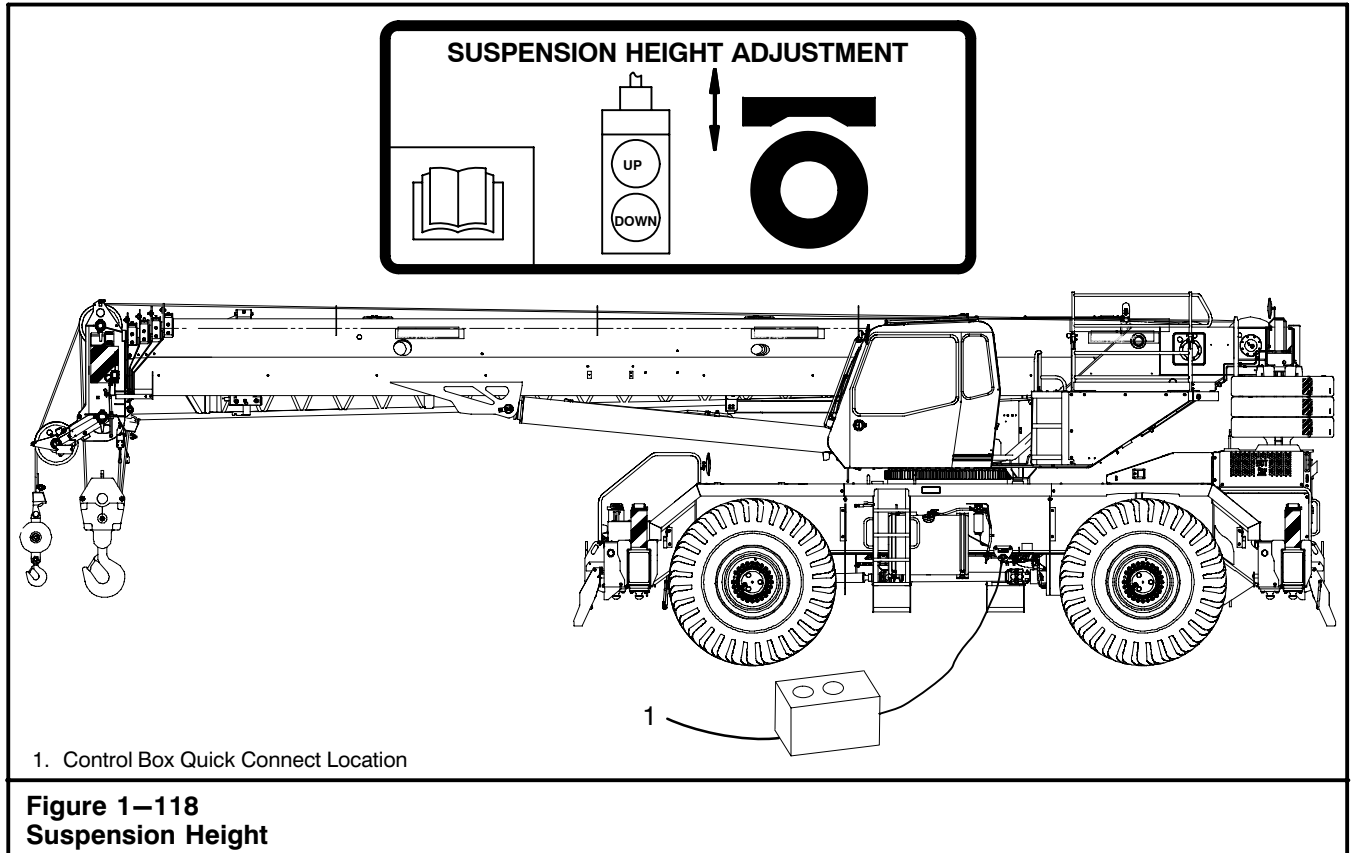

Suspension Height Adjustment

The oscillation suspension cylinders can be retracted to reduce the overall height of the crane during transport. A hand held electrical control box with 20 ft (6.1m) of cable is used to adjust the height of the crane. This is the same electrical control box as used on the counterweight removal option. Quick connect electrical connection is provided under the left fender.

Once the crane reaches the job site and is unloaded from the transport vehicle, the suspension must be properly adjusted to the correct travel height before operating the crane.

CAUTION

Do not travel the crane with the axle oscillation cylinders fully extended or fully retracted. Major damage to suspension components can occur if the crane's oscillation suspension is not properly adjusted. Oscillation cylinders which are not properly adjusted can leave suspension components unprotected from shock loads which can lead to major crane damage. Inspect the axle oscillation cylinders daily for the proper adjustment as required.

Use the following procedures to adjust the travel height.

1. Park the crane on a firm level surface.
2. Position the upper directly over the front of the carrier, fully retract the boom and lower to 0 degree angle, and engage the travel swing lock.
3. Measure the non-painted rod length for each oscillation cylinder. The sum of the exposed rods should equal 4.0 in \pm 0.125 in (10.16cm \pm 0.3cm). If suspension cylinders are not within specification proceed to the next step.
4. With the crane on a firm, level surface and on tires, push the UP button to extend the oscillation cylinders until the measured sum of the exposed rods equals 4.0 in (10.16cm).

Note: Do not retract suspension cylinders to obtain the measured sum of the exposed rods.

5. On cranes equipped with the Hydro-gas option, press the DOWN button and hold for approximately 30 seconds. Then press the UP button until the non-painted rod length equals 4.0 in \pm 0.125 in (10.16cm \pm 0.3cm).
6. For transporting the crane, the suspension may be fully lowered exposing 0 in (0 cm) of rod length. If equipped with hydro-gas suspension, press the DOWN button and hold for approximately 30 seconds.
7. Disconnect the control box and store in the crane's tool box under the operator's seat.

Operator's Manual

Crane Storage

Anytime the crane is going to be left unattended it should be prepared so that it will not be damaged by the elements, be an attraction to vandals, or a plaything for children.

Short Term Storage

1. Do not leave crane where it will be a traffic hazard.
2. Lower all loads to the ground.
3. The travel swing lock must be engaged.
4. Fully retract the boom. Boom down to 0°. The fly may be erected if the crane is on outriggers.
5. Tie off the hook block and/or hook ball to the tow lugs. Winch lines should be snug.
6. All control levers must be in the neutral position.
7. Shift the transmission to neutral, engage the park brake, and shutdown the engine. Block the wheels to prevent the crane from rolling if on tires.
8. If the crane is on outriggers, the outriggers must be properly set and supported so the crane will remain level.
9. In cold weather, park the crane where it will not freeze to the ground.
10. To preserve battery life, move the battery disconnect switches to the off position.
11. Remove the keys from the crane. Lock all windows and doors.

Long Term Storage

1. Store the crane inside a building if possible.
2. Thoroughly clean the crane.
3. Touch up any spots where paint has chipped. This will prevent rusting.
4. Lubricate the entire crane as per the Lubrication Chart. Ensure all gear cases are filled to their proper oil level.
5. Inflate tires to proper pressure as shown on the Tire Inflation Label or the Tire Inflation Chart in the Crane Rating Manual. Check tire pressures periodically during storage to ensure they do not go flat. If possible block the crane up so the tires are clear of the ground. Ensure the blocking is placed so the crane cannot fall off it. If this is not possible, set the crane on planks so the tires will not sink in the ground. Block the tires to prevent the crane from rolling.
6. Fully retract all hydraulic cylinders if possible. Fully retract the boom and store the fly, if equipped. Cover all cylinder rods, machined, and unpainted surfaces with a coat of grease.
7. Position all control levers in neutral.
8. Engage the park brake, shift the transmission to neutral, and shutdown the engine.
9. Prepare the engine as per the engine manufacturer's manual. Ensure antifreeze protection is sufficient to prevent the engine from freezing.
10. After engine has cooled, cover all open areas around engine, cab, etc. to prevent entry of water. Cover entire engine area with a tarp if possible.
11. To preserve battery life, move the battery disconnect switches to the off position.
12. Remove the keys and lock the cab doors if in a location where vandalism may occur. Cover all cab glass with plywood or boards to prevent glass breakage. Provide a means of locking the engine access doors, fuel tank, and hydraulic reservoir.
13. Store the crane so it does not provide a plaything for children. Such a unit can be an "attractive nuisance" for children to play on. If they fall off it or get entangled, serious injury may result.
14. While in storage, crane should be "exercised" every 60 days to ensure the working condition of the crane. Remove necessary tarps, start engine, and operate all switches, control cables, and hydraulic functions several times to circulate lubricants and to keep all mechanisms and linkages operative.

Table Of Contents

| | |
|--|-------------|
| General Lubrication Information | 2-1 |
| Lubrication Chart | 2-2 |
| Lubrication Specifications | 2-4 |
| Hi Performance Hydraulic Oil | 2-9 |
| Disposal Of Used Lubricants, Fluids, Etc. | 2-9 |
| Transmission And Torque Convertor Lubrication | 2-10 |
| Transmission Oil Level Check | 2-10 |
| Transmission Filter Change | 2-11 |
| Transmission Oil Change | 2-11 |
| Engine Cooling System | 2-12 |
| Cooling System Test | 2-12 |
| Cooling System Level Check | 2-12 |
| Cooling System Coolant Change | 2-14 |
| Engine Fuel Filter | 2-15 |
| Fuel Filter Water Drain | 2-15 |
| Fuel Filter/Water Separator Change | 2-16 |
| Secondary Fuel Filter Change | 2-16 |
| Axle Differentials Lubrication | 2-17 |
| Axle Differentials Oil Level Check | 2-17 |
| Axle Differentials Oil Change | 2-17 |
| Planetary Wheel End Lubrication | 2-18 |
| Planetary Wheel End Oil Level Check | 2-18 |
| Planetary Wheel End Oil Change | 2-18 |
| Wheel Bearing Lubrication | 2-19 |
| Hydraulic Reservoir | 2-19 |
| Water Drain | 2-19 |
| Hydraulic Reservoir Oil Level Check | 2-19 |
| Adding Oil To The Hydraulic Reservoir | 2-19 |
| Hydraulic Reservoir Filter Change | 2-19 |
| Hydraulic Reservoir Oil Change | 2-21 |
| Engine Air System Inspection | 2-22 |
| Engine Air Cleaner | 2-22 |

Operator's Manual

| | |
|---|-------------|
| Changing The Air Cleaner Element | 2-22 |
| Drive Tube And U-Joint Lubrication | 2-23 |
| Telescope Valve In-Line Filter Cleaning | 2-24 |
| Winch Drum(s) Lubrication | 2-25 |
| Winch Drum Oil Level Check | 2-25 |
| Winch Drum Oil Change | 2-25 |
| Swing Speed Reducer Lubrication | 2-27 |
| Swing Speed Reducer Oil Level Check | 2-27 |
| Swing Speed Reducer Oil Change | 2-27 |
| Boom Inspection & Lubrication | 2-28 |
| Fly Inspection & Lubrication | 2-28 |
| Wire Rope Lubrication | 2-29 |
| Application Of Wire Rope Lubricant | 2-29 |
| Hook Block, Hook Ball, And Swivel Inspection And Maintenance | 2-30 |
| Turntable Bearing Capscrew Torque | 2-31 |
| Turntable Bearing Capscrew Inspection Schedule | 2-31 |
| Crane Monitoring System | 2-32 |
| Hydraulic Hose Assembly Inspection | 2-32 |
| Paint Maintenance | 2-33 |
| Regular Preventative Maintenance | 2-33 |
| Polishing And Waxing Procedure | 2-33 |
| Cab Dash Cleaning | 2-33 |

Operator's Manual

General Lubrication Information

The crane should be regularly and systematically lubricated in accordance with the Lubrication Chart shown on the following pages. Refer to Figure 2–1. Another copy of the chart is on the carrier. The time intervals shown on the Lubrication Chart are intended as a guide only. Under unusual working conditions, such as working in dry, dusty conditions, in water or mud, or around a corrosive atmosphere, more frequent lubrication could be necessary. In these cases, the oiler must use good judgment and work out a proper lubrication schedule.

In addition to the points on the Lubrication Chart, all movable linkages and control cables should be periodically lubricated to resist wear. The only exception is the boom internal components as they do not require periodic lubrication.

There are some very practical reasons for lubricating and lubricant changes. Lubricants serve more than one purpose. They not only lubricate, but they transport chemically reactive additives, wash away minute wear particles, serve as a corrosion inhibitor, and act as a heat transfer medium. Draining and refilling any gear unit with a fresh supply of oil also assists in eliminating wear particles not trapped by magnetic plugs.



WARNING

Shutdown engine before fueling or lubricating crane. To avoid a fire hazard, do not smoke or handle fuel around an open flame. To prevent serious personal injuries and to avoid crane damage, do not lubricate gears or any assemblies while they are in motion.

The following procedures are important for proper lubrication of the crane:

1. Clean the grease gun nozzle and grease fitting before lubricating. This will help keep dirt and grit from entering the bushing or bearing.
2. Keep all grease and oil cans and containers clean. Always replace the lid on containers when finished to prevent entry of foreign materials. Wipe off oil can covers before using.
3. Drain oil cases when hot to drain off accumulated sludge.
4. Watch for signs of incorrect lubrication such as failure of clean grease to purge the old grease.
5. Bleed off hydraulic pressure before opening or removing a line or fitting.
6. Replace all guards before starting crane.
7. Use a clean funnel equipped with a strainer for pouring lubricants.
8. Clean the area around check and fill plugs before removing them to prevent entry of foreign particles.



DANGER

When it is required to operate the crane during maintenance and/or adjustments, use extreme caution as service personnel may have to work near and/or under moving machinery. Serious personal injury and/or death may result. Always remain in visual and/or verbal contact to ensure the safety of service personnel. Use a signal person if necessary.

Note: See specific instructions in this Section of this Operator's Manual for lubrication check and change procedures on all gear compartments.

Keep grease, oil containers, and guns clean. Wipe all fittings before lubrication. Raise the crane on outriggers or block the wheels and shutdown the engine before working on the crane. Replace all guards and panels before operating the crane.

Operator's Manual

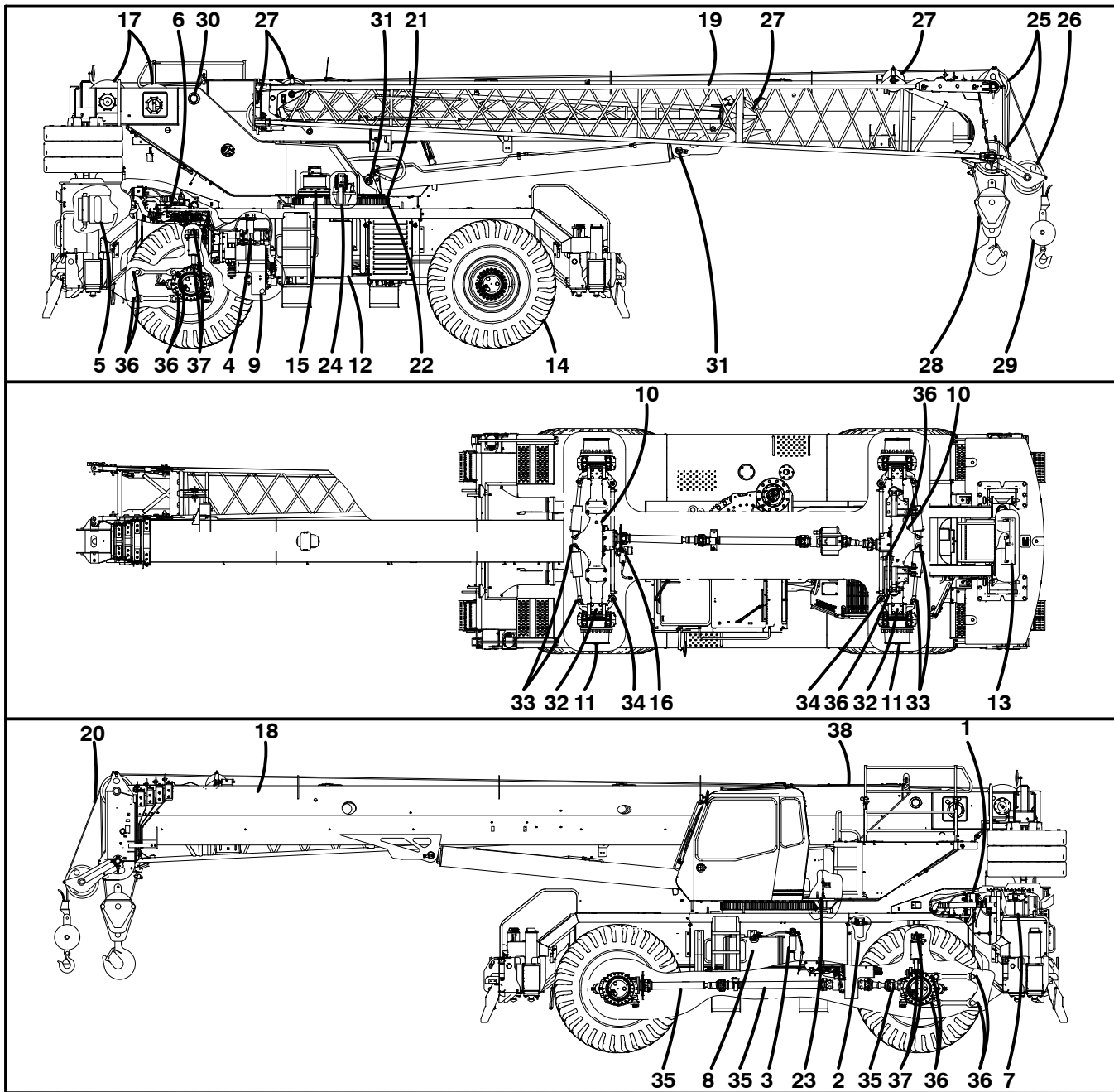

CAPACITY

| Location | Gallons | Liters |
|---------------------------------|---------|--------|
| Engine Oil | 3.75 | 14.2 |
| Engine Coolant | 10.80 | 40.9 |
| Transmission & Torque Converter | 6.75 | 25.6 |
| Axle Differential (ea) | 5.00 | 18.9 |
| Planetary Wheel Ends (ea) | 1.00 | 3.8 |
| Fuel Tank | 75.00 | 283.9 |
| Hydraulic Reservoir | 153.00 | 579.2 |
| Hydraulic System | 215.00 | 813.9 |
| Heater Coolant | 0.79 | 3.0 |
| Swing Speed Reducer | 1.20 | 4.5 |
| Swing Brake | 0.08 | 0.3 |
| Winch Drums (ea) | 4.50 | 17.0 |
| Heater Fuel Tank | 3.20 | 12.1 |

LUBRICATION CODE IDENTIFICATION

| Lube Code | Recommended Type |
|-----------|--|
| A | Grease, NLGI Grade No. 2 |
| E | Extreme Pressure Gear Lubricant, 80W/90 |
| H | Grease (Summer Grade) |
| U | Gear Lubricant, 80W-85W-140 |
| HH | Gear Lubricant |
| KK | Grease, NLGI Grade No. 1 |
| LL | Extreme Pressure Gear Oil, 75W/90 |
| QQ | Synthetic Gear Oil |
| WW | Transmission And Torque Fluid, Type TO-4 |

Figure 2-1
Lubrication Chart

Operator's Manual

| MAINTENANCE | | | | | | |
|-------------------------------------|------------------|--------------------------|-----------|-------|------------------------|------------------------|
| Location | Reference Number | Service Interval (Hours) | Operation | Key | Lube Code Above -10° F | Lube Code Below -10° F |
| Engine Cooling System | 1 | 10 | *,X | 1,2,3 | Key 2 | Key 2 |
| | | Key 2 | + | 1,2,3 | Key 2 | Key 2 |
| Engine Oil | 2 | 10 | * | 1,2,3 | Key 2 | Key 2 |
| | | Key 2 | 0,+ | 1,2,3 | Key 2 | Key 2 |
| Primary Fuel Filter/Water Separator | 3 | 10 | \$ | 1,2,3 | Key 2 | Key 2 |
| | | Key 2 | # | 1,2,3 | Key 2 | Key 2 |
| Secondary Fuel Filter | 4 | Key 2 | # | 1,2,3 | Key 2 | Key 2 |
| Engine Air Cleaner | 5 | 10 | 0 | 1,2,3 | N/A | N/A |
| Engine Crankcase Filter | 6 | Key 2 | # | 1,2,3 | N/A | N/A |
| Diesel Particulate Filter | 7 | Key 2 | @ | 1,2,3 | N/A | N/A |
| Fuel Tank | 8 | 10 | * | 1,2,3 | Key 2 | Key 2 |
| Transmission | 9 | 10 | * | 1,3 | WW | WW |
| | | 500 | # | 1,3 | WW | WW |
| | | 1000 | + | 1,3 | WW | WW |
| Axle Differentials | 10 | 50 | * | 1,3 | U | LL |
| | | 1000 | + | 1,3 | U | LL |
| Planetary Wheel Ends | 11 | 50 | * | 1,3 | U | LL |
| | | 1000 | + | 1,3 | U | LL |
| Hydraulic Reservoir | 12 | 10 | *, \$ | 1,3 | Key 3 | Key 3 |
| | | 500 | # | 1,3 | Key 3 | Key 3 |
| | | 2000 | + | 1,3 | Key 3 | Key 3 |
| Batteries | 13 | 50 | 0 | 1 | N/A | N/A |
| Tires | 14 | 10 | 0 | 1,3 | N/A | N/A |
| Swing Speed Reducer | 15 | 50 | * | 1,3 | E | LL |
| | | 1000 | + | 1,3 | E | LL |
| Park Brake | 16 | 250 | 0 | 1,3 | N/A | N/A |
| Winch Drum(s) | 17 | 50 | * | 1,3 | HH | QQ |
| | | 1000 | + | 1,3 | HH | QQ |
| Boom | 18 | 10 | 0 | 1,3 | N/A | N/A |
| Fly | 19 | 10 | 0 | 1,3 | N/A | N/A |
| Wire Rope | 20 | 10 | 0 | 1,3 | Key 3 | Key 3 |

| LUBRICATION | | | | | |
|---------------------------|------------------|------------------|-----------------------|------------------------|------------------------|
| Location | Reference Number | Number of Points | Lube Interval (Hours) | Lube Code Above -10° F | Lube Code Below -10° F |
| Turntable Bearing | 21 | 1,Key 4 | 50 | A | KK |
| Turntable Gear Teeth | 22 | All | 50 | H | H |
| Travel Swing Lock | 23 | 1 | 250 | A | KK |
| 360 Degree Swing Lock | 24 | 4 | 50 | A | KK |
| Boom Head Machinery | 25 | All | 50 | A | KK |
| Auxiliary Lifting Sheave | 26 | 1 | 50 | A | KK |
| Fly Sheaves (Base & Tip) | 27 | 4 | 50 | A | KK |
| Hook Block & Sheaves | 28 | All | Key 3 | A | KK |
| Hook Ball | 29 | 1 | Key 3 | A | KK |
| Boom Foot Pin | 30 | 2 | 10 | A | KK |
| Boom Hoist Cylinder Pins | 31 | 2 | 10 | A | KK |
| Steering Knuckles | 32 | All | 50 | A | KK |
| Steering Cylinder Ends | 33 | 8 | 50 | A | KK |
| Tie Rod Ends | 34 | 4 | 50 | A | KK |
| Axle Drive Tubes/U-joints | 35 | 8 | 50 | A | KK |
| Rear Suspension Links | 36 | 10 | 50 | A | KK |
| Oscillation Cylinder Pins | 37 | 4 | 250 | A | KK |
| Boom Locking Pins | 38 | 4 | 50 | A | KK |

1. SYMBOLS:

KEY

- * Check fluid level and fill as required.
- 0 Inspect, lubricate, adjust, repair, or replace as required.
- + Change oil (and filter if applicable).
- # Change filter only.
- @ Clean filter/strainer as necessary.
- X Clean fins if needed.
- \$ Drain water.
- N/A Not applicable.
- A,E,H,U, etc. Lubrication codes. Refer to Lubrication Code Identification on this chart. Link-Belt recommends the lubrication types on this chart, however if an equivalent is to be used, refer to the Operator's Manual for detailed specifications to ensure a correct equivalent is used.

2. Refer to engine manufacturer's manual for proper maintenance, lubrication, fuel or coolant grade, and additional information.
3. Refer to the Operator's Manual for additional information.
4. Lubricate the turntable bearing through the grease fittings on the front of the upper frame. Use a low pressure handgun and pump grease until clean grease comes out. Rotate the upper a few degrees and pump grease until clean grease comes out again. Repeat throughout the 360° cycle.

Operator's Manual

Lubrication Specifications

The following specifications are approved for use in Link-Belt cranes. The specifications are identified by a code letter. When a code letter appears on the lubrication or maintenance chart, it is referring to one of the lubricants as described on the following pages. These lubricants are listed by specifications and by one brand name. Most reputable oil companies can provide a lubricant to match a particular specification. It may then be used in the crane no matter what the brand name. When using other brand names, the user assumes all responsibility for product and patent liability.

Type A

Grease, NLGI Grade No. 2

A mineral oil based, multipurpose lithium complex extreme pressure (EP) grease. Composed of a lithium complex soap, compounded with highly refined paraffinic base oils and formulated with a special additive package to provide rust and corrosion protection, resistance to water washout, oxidation stability, and wear protection under high loads. It meets the requirements of ASTM D4950 GC-LB covering wheel bearing and chassis greases. Recommended for use as a multipurpose industrial grease, particularly where temperature operation is of concern.

Typical Characteristics:

| | |
|---|-------------|
| Appearance | Blue, Tacky |
| Lithium Complex Soap, wt % | 10 |
| Penetration, D 217, Worked 60 X | 280 |
| D 217, Worked 10,000 X % Change | 10 |
| Dropping Point, Mettler, °F (°C) | 450+ (232+) |
| Mineral Oil Viscosity, D 445 | |
| cSt at 104°F (40 °C) | 150–205 |
| cSt at 212°F (100 °C) | 14.5–18 |
| Rust Protection, D 1743 | Pass |
| Copper Corrosion, D 4048 | 1B |
| Timken, OK Load, lbs, D 2509 | 40 |
| Four-Ball EP, D 2596 | |
| Load Wear Index, kgf | 46 |
| Weld Point, kgf | 250 |
| Four-Ball Wear, mm, D 2266 | 0.4 |
| 1 hr, 167°F (75 °C), 1200 rpm, 40 kg | |
| Water Washout, wt % loss at | |
| 100°F (38 °C) D 1264 | 4 |
| Grease Mobility, U.S. Steel Method g(l)/min | |
| –30°F (34 °C) | 0.0 (0) |
| –20°F (29 °C) | 0.5(1.9) |
| 0°F (–17 °C) | 5.5(20.8) |
| 20°F (7 °C) | 30(113.6) |
| Guide to Usable Temperature | |
| Min., °F (°C) | –20 (–29) |
| Continuous Service, Max, °F (°C) | 325 (163) |
| Short Exposure, Max, °F (°C) | 450 (232) |

Shell Code 70311 – ALBIDA LC or Equivalent.

Type E

Extreme Pressure Gear Lubricant, 80W/90

An extreme pressure gear lubricant containing anti-foam protection, oxidation stability, anti-rust, and anti-corrosion qualities. Contains sulfur and phosphorus additive materials but no zinc in compliance with Eaton, General Motors, and International Harvester truck driving axle requirements.

Must meet or exceed military specification MIL-PRF-2105E, and is suitable for API service designations GL3, GL4, MT-1, and GL5, with a rating of 10 as determined in the shock load test CRC-L-42.

Used in hoist reducer, swing reducer, driving axles, and drop transmissions.

Physical Properties:

| | |
|------------------------------------|---------------------|
| Appearance | Very Dark Red, Dark |
| Gravity, °API | 25.7–27 |
| Flash, COC, (Min) (°F) (°C) | 375 (191) |
| Pour Point, (Max) (°F) (°C) | –20 (–29) |
| Viscosity, Max @ 100°F (38 °C) SUS | 829 |
| Viscosity, Max @ 210°F (99 °C) SUS | 72.5 |
| Viscosity Index | 95–100 |
| Sulfur | 2.37 |
| Ash (%) | None |
| CU Corr 3 Hours 250°F (121 °C) | 1 b |
| Channel Point, Max (°F) (°C) | 0 (–17) |
| Timken Test Lever Load lb (Min) | 50 |
| Phosphorus (%) | 12 |

Shell 59210 Spirax HD 80W/90 or Equivalent.

Type H

Grease (Summer Grade)

For open gear applications. Satisfactory down to -40°F (-40°C) on dry gears. Good adhesiveness on open gears at 73°F (22.7°C) and good retention. The grease with use will become tacky and will resist leaking. Used on cast tooth gears and ring gear teeth. Extremely resistant to water washing.

Physical Properties:

Mineral Oil Component:

| | |
|--|----------------|
| Viscosity at 100°F (38°C) SUS | 4545 |
| Viscosity at 210°F (99°C) SUS | 170 |
| Load Wear Index | 56 |
| Penetration, Worked at 77°F (25°C) (60 Strokes) | 280 |
| Dropping Point, Min ($^{\circ}\text{F}$) ($^{\circ}\text{C}$) | 222(105) |
| Soap Base – Calcium (%) with 22% graphite and 3% Molybdenum Disulfide | 9.0 |
| Water (%) | 0.5 |
| Recommended Max Temperature ($^{\circ}\text{F}$) ($^{\circ}\text{C}$) | 175 (79) |
| Consistency | Buttery Grease |
| Color | Black–Gray |

Shell 71228 – Rhodina SDX Grease 2 or Equivalent.

Type U

Multi-Grade Gear Lubricant ,SAE 80W-85W-140

Good quality gear lube, for both high and low temperature extremes. Good lubricant for most enclosed gear applications, axle and transmission requirements. With synthetic hydrocarbons, sulphur, phosphorus type of additives and with additives to prevent rusting and foaming. Exceeds API classifications GL4 and GL5. It is qualified under MIL–L–2105B, MIL–L–2105C and MIL–L–2105D; Rockwell Standard (Timken) 0–76B; Mack GO–D and GO–F; and International Harvester SP lubrication specifications.

Physical Properties:

| | |
|---|------------------|
| SAE Viscosity Number | 80W-85W-140 |
| Gravity, $^{\circ}$ API | 23.6 – 26.8 |
| Brookfield Viscosity, @ -15°F (-26°C) Cp | 75,000 – 134,000 |
| Viscosity, cSt, 100°F (38°C) | 240 – 271 |
| 210°F (99°C) | 26 – 30.5 |
| Viscosity Index, (D–2270) | 125 – 152 |
| Pour Point, ($^{\circ}\text{F}$) | -20 – -40 |
| ($^{\circ}\text{C}$) | -29 – -40 |
| Non-Channeling Temperature, ($^{\circ}\text{F}$) | -40 |
| ($^{\circ}\text{C}$) | -40 |
| Sulfur % | 2.0 |
| Phosphorus % | 0.11 |
| Specific Gravity, @ 60°F (16°C) | 0.8939 – 0.9123 |
| Pounds Per US Gallon, @ 60°F (16°C) | 7.443 – 7.6 |
| Flash Point, COC, ($^{\circ}\text{F}$) | 310 – 410 |
| ($^{\circ}\text{C}$) | 154 – 210 |
| Timken OK Load, Pounds | 40 – 85 |

Kendall Refining Company – Kendall Super Three Star SAE 80W–85W–140 (Product Code 7720) or Equivalent.

Operator's Manual

Type HH

Gear Lubricant

This gear lubricant is suitable for use in a wide variety of mobile equipment gear and brake applications. Has good oxidation and thermal stability, is non-corrosive to most gear and bearing materials, and is inhibited to provide good foam resistance and water separation characteristics. Has moderate concentration of EP additives.

Must meet performance requirements of AGMA Specification 250.04 for extreme pressure lubricants. Is suitable for API service designations of GL2 and GL3.

Typical Characteristics:

| | |
|--------------------------------|---------------|
| Appearance | Very Dark Red |
| Gravity, °API | 26.7–29 |
| Flash, COC, Min °F (°C) | 410 (210) |
| Pour Point, Max °F (°C) | –10 (–23) |
| Viscosity cSt @ 104°F (40 °C) | 150 |
| Viscosity cSt @ 212°F (100 °C) | 14.4 |
| Viscosity SUS @ 100°F (38 °C) | 796 |
| Viscosity SUS @ 210°F (99 °C) | 76 |
| Viscosity Index | 95–100 |
| Sulfur, % | 0.66 |
| Phosphorous, % | 0.03 |
| Timken OK Load, Lbs (Min) | 60 |
| AGMA No. EP | 4 |

Shell 65104, OMALA 150 or Equivalent.

Type KK

Grease NLGI Grade No. 1

Low temperature, extreme pressure, synthetic all purpose grease made from a low pour point synthetic hydrocarbon lubricant, thickened with lithium or clay. The grease is fortified with an extreme pressure additive and a rust inhibitor to provide even better equipment protection.

A multi-purpose grease that can be pumped from normal grease dispensing equipment at temperatures down to a –55°F (–48 °C). Good for heavy duty operation.

Recommended for use in centralized lube systems, wheel bearings, chassis bearings, universal joints, and all other applications requiring a grease of this type. Offers full protection regardless of the season. Pumpable at –55°F (–48 °C), even in a hand grease gun. Excellent anti-wear and load carrying ability, stays in place better than lighter greases, waterproof to resist wash-out, good shear stability. Assures good high temperature performances. Compatibility of this grease with ordinary greases presents no problems.

Physical Properties:

| | |
|---|-----------------|
| Thickener | Lithium or Clay |
| Penetration worked @ 77°F (25 °C) (ASTM D217) | |
| 60 strokes | 315–325 |
| Texture | Smooth |
| Dropping Point, (°F) (°C) | |
| (ASTM D2265) Max | +500 (260) |
| Viscosity (ASTM D445) cSt | |
| 104°F (40 °C) | 26.2–32 |
| 212°F (100 °C) | 5.08–5.2 |
| Rust Properties (ASTM D1743) | Pass |
| Four Ball, EP (ASTM D2596) | |
| Wear, mm, Max | 0.7 |
| Weld, kg, Min | 250 |
| Color | Red or Brown |

Exxon Mobil Mobiltemp SHC 32 or Equivalent.

Type LL

Extreme Pressure Gear Oil, 75W/90

A synthetic, extreme pressure gear oil designed for cold weather operation in hypoid, spiral bevel, and planetary gear axles. Must meet the requirements of Military Specification MIL-PRF-2105E. Meets API GL-5 and MT-1 performance ratings

Physical Properties:

| | |
|--|-----------|
| Gravity, °API (ASTM D-1298) . . . | 25.2-33.3 |
| Kinematic Viscosity, (ASTM D-443) | |
| Min @ 212°F (100 °C), cSt | 15.5 |
| Max @ 104°F (40 °C) | 126 |
| Apparent Viscosity, (ASTM 2983) (Brookfield) | |
| Max @ -40°F (-40 °C), ml | 150,000 |
| Flash Point (ASTM D-92) | |
| Min °F (°C) | 400 (204) |
| Pour Point (ASTM D-97) | |
| Max °F (°C) | -49 (-45) |
| Viscosity Index (ASTM D-2270) . . | 140-151 |
| Copper Corrosion, (ASTM D-130) | |
| 3 hrs. @ 250°F (121 °C) Max | 3 |
| Foaming Characteristics (ASTM D-892) | |
| (Foam readings taken immediately | |
| after 5 minutes aeration) | |
| Max @ 75°F (24 °C), ml | 20 |
| Max @ 200°F (94 °C), ml | 50 |
| Storage Stability, % Max | |
| (FTMS 791B Method 3440) | 0.25 |
| Compatibility | |
| (FTMS 791B Method 3430) | Note 1 |

The latest revision of all referenced specifications and test methods shall be used.

FTMS= Federal Test Method Standard.

Note 1: Use approved per Eaton PS-163 and Mack GO-J Plus.

Mobil Oil Molilube SHC 75W/90, Code No. 51100-6 or Equivalent.

Type QQ

Synthetic Gear Oil

A specially formulated lubricant for applications where service conditions are severe because of high operating and bulk oil temperatures. Typical applications are spur, helical, herringbone, bevel, and planetary gears and gear boxes with multiple disc brakes. Lubricant is derived from synthetic based oils that are more resistant to thermal and oxidation degradation. Can offer advantages of extension of lubricant life and reduced risk of damage to machine elements.

Typical Characteristics:

| | |
|---|------------|
| AGMA Grade No. | 4 EP |
| Gravity, °API | 25.5-34.4 |
| ISO Viscosity Grade | 150 |
| Viscosity, Cst (ASTM D-445) | |
| @104°F (40 °C) | 140 |
| @ 212°F (100 °C), Cst | 14.0 |
| Viscosity, SUS (ASTM D-2161) | |
| @ 100°F (38 °C) | 737 |
| @ 210°F (99 °C) | 75-100 |
| Viscosity Index | 96-150 |
| Pour Point, | |
| (ASTM D-97) °F (°C) | -23 (-10) |
| Flash Point, COC, (ASTM D-92) | |
| °F (°C) | 229-460 |
| Rust Test, Distilled Water, | |
| (ASTM D-665) | Pass |
| Copper Corrosion Test | |
| 24 hr. -30 hr. @ 212°F (100 °C) | 1b |
| Timken Extreme Pressure Test | |
| (ASTM D-2782) Pass Value (lbs) | 60 |
| FZG Test, Stages, Pass | 12 |
| Phosphorus, Wt. % | 0.005-0.03 |

Mobil SHC 629 or Equivalent.

Operator's Manual

Type WW

Transmission And Torque Fluid, Type TO-4

High viscosity index characteristics permit use over a wide temperature range by providing excellent low temperature fluidity and at the same time retaining their desired viscosity at high temperature conditions. High temperature oxidation resistance, dispersancy, detergency, anti-corrosion, and rust protection. Has special friction characteristics and compatibility with the various automatic transmission components such as elastomeric seals. Compatible with synthetic and rubber seals as Buna N, polyacrylate and silicone in transmissions minimizing the possibility of leakage.

To meet all the requirements of Caterpillar hydraulic transmission fluid type TO-4 specifications.

Physical Properties:

| | |
|--------------------------------------|---------------|
| Gravity, °API | 35.2 |
| Viscosity @ 100°F (38 °C), SUS | 546 Max |
| Viscosity @ 210°F (99 °C), SUS | 50.9 Min |
| Viscosity Index | 134 Min |
| Flash COC °F (°C) | 408 (208) Min |
| Pour Point °F (°C) | -38 (-39) Max |
| Ash % (Sulfated) | <1.0 |

Exxon Mobil – Mobil Trans AST or Equivalent.

Hi Performance Hydraulic Oil

Important

Use only pre-filtered hydraulic oil. Warranty is void if incorrect oil is used. Incorrect oil may result in damage to hydraulic components. Hi Performance Hydraulic Oil is available through a Link-Belt Distributor in the following grades and quantities.

| Oil Grade | Temperature Range | | Container Capacity | | Part Number |
|-----------------|---------------------------------|--------------------------------------|--------------------|--------|------------------------|
| | Ambient Temperature Use | Maximum Hydraulic System Temperature | Gallons | Liters | |
| Grade 22 | -45°F to 80°F -43°C to 27°C | 150°F 65°C | 5 | 18.9 | 830666001 830666002 |
| | | | 55 | 208.2 | |
| Grade 46 | 10°F to 100°F -12°C to 38°C | 200°F 93°C | 5 | 18.9 | 830663001 830663002 |
| | | | 55 | 208.2 | |
| All Temperature | -40°F to 100°F -40°C to 38°C | 200°F 93°C | 5 | 18.9 | 830673001 830673002 |
| | | | 55 | 208.2 | |

Disposal Of Used Lubricants, Fluids, Etc.

Properly dispose of used lubricants and filters. Every drop of misplaced oil damages the environment. Each year literally thousands of gallons of used oil is dumped into our fields and streams or buried in community landfills. These methods of disposal permanently damage the world around us. You can see that the oil you use is properly disposed of by sending it to a recycling center. Most local automobile service stations are happy to receive used oil and will see to it that the oil is recycled. Refer to the latest EPA, state, and local regulations regarding proper disposal.



Figure 2-2
Please Don't Do It!

Operator's Manual

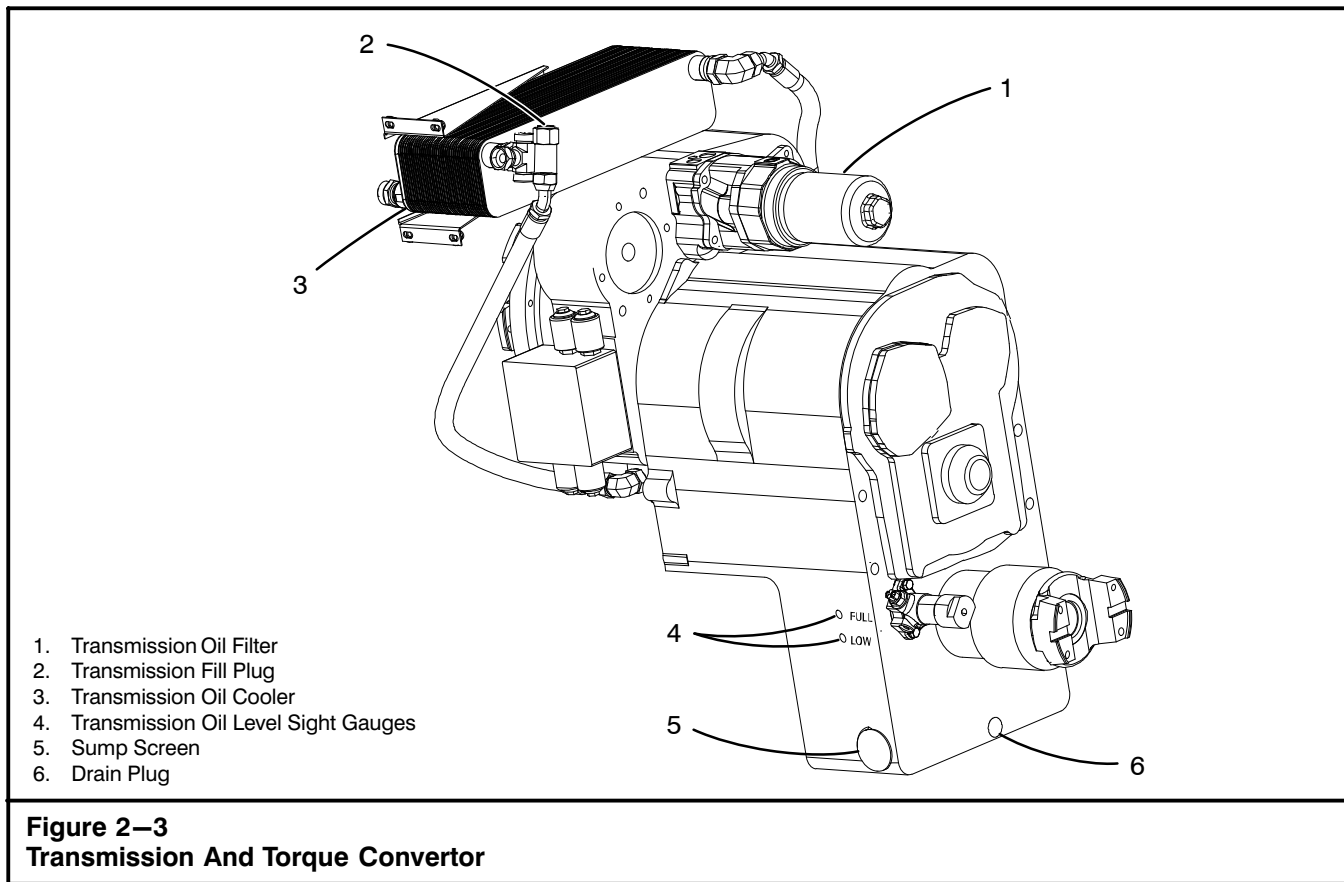

Transmission And Torque Converter Lubrication

The transmission and torque converter share the same oil which is serviced at the transmission. In order for both units to work properly, the correct oil level must be maintained and the oil and filters changed periodically. If the oil level is low, the internal transmission and converter parts may not receive adequate lubrication. This will cause poor performance and lead to failure. If the oil level is too high, the oil will aerate and overheat which can also cause component failure. Use the following procedures to properly service the transmission and torque converter.

Transmission Oil Level Check

Check the transmission oil level daily. Dirt or foreign material should not be permitted to enter the transmission oil system. It can cause valves to stick, oil passages to clog, and excessive wear on internal transmission parts.

1. Operate the crane in a drive range until the transmission oil reaches its normal operating temperature 180–200°F (82–93 °C).

Note: Under certain conditions it may be necessary to stall out the converter to bring the transmission oil to operating temperature. To stall out the converter, shift the transmission to “3”, hold the brakes and accelerate engine to full throttle. Continue in this position until proper operating range is reached.

CAUTION

Using full throttle speed and stalling out the converter for an excessive length of time will overheat the converter.

2. Park the crane on a firm level surface, apply the park brake and shift the transmission to neutral. Leave the engine running at idle speed.
3. Find the transmission oil level sight gauges on the left side of the transmission. Refer to Figure 2-3.
4. Shutdown the engine and add oil as required through the fill plug hole to bring the level to the sight gauge marked “FULL”. Use only the oil type specified on the Lubrication Chart. Do not overfill.

Transmission Filter Change

Change the transmission oil filter after the first 50 and 100 hours of operation and every 500 hours of operation thereafter. The transmission oil filter is mounted on the transmission. Refer to Figure 2–3.

1. Park the crane on firm level ground, shift the transmission to neutral, apply the park brake, and shut-down the engine.
2. Clean the area around the filter housing to prevent contamination from entering the system.
3. Turn the filter housing counterclockwise to remove it.
4. Remove filter element and o-ring seal. Properly dispose of the used filter element and seal.
5. Coat the new o-ring seal with clean transmission fluid before installation.
6. Install new seal and filter element. Install filter housing onto the filter adaptor.
7. Check transmission oil level. Refer to “Transmission Oil Level Check” in this Section of this Operator’s Manual.
8. Start the engine and inspect the system for leaks.
9. Properly dispose of the used oil.

Transmission Oil Change

Change the transmission oil every 1,000 hours of operation or seasonally, whichever occurs first. Change it more often if job site conditions demand. If the oil has overheated, change it and the filter immediately.

1. Operate the crane in a drive range until the transmission oil reaches its normal operating temperature 180–200°F (82–93 °C).

Note: Under certain conditions it may be necessary to stall out the convertor to bring the transmission oil to operating temperature. To stall out the convertor, shift the transmission to “3”, hold the brakes and accelerate engine to full throttle. Continue in this position until proper operating range is reached.

CAUTION

Using full throttle speed and stalling out the convertor for an excessive length of time will overheat the convertor.

2. Park the crane on firm level ground, shift the transmission to neutral, apply the park brake, and shut-down the engine.
3. Clean the area around the drain plug and sump screen. Refer to Figure 2–3.
4. Remove the transmission drain plug. Allow the oil to drain into a suitable container.
5. Remove sump screen, clean and reinstall it.
6. Replace transmission filter. Refer to “Transmission Filter Change” in this Section of this Operator’s Manual.
7. Install transmission drain plug.
8. Fill transmission with oil to the sight gauge marked “LOW”. Refer to “Transmission Oil Level Check” in this Section of this Operator’s Manual. Use only the oil specified on the Lubrication Chart.
9. Start the engine and let it idle a few minutes. This will prime the convertor lines.
10. Recheck the transmission oil level with the engine idling. Add oil until it comes to the sight gauge marked “LOW”.
11. Operate the crane until the oil reaches 180–200° F (82–93 °C). Make final oil level check. Add oil as required to bring the level to the sight gauge marked “FULL”.
12. Check the system for leaks.

Operator's Manual

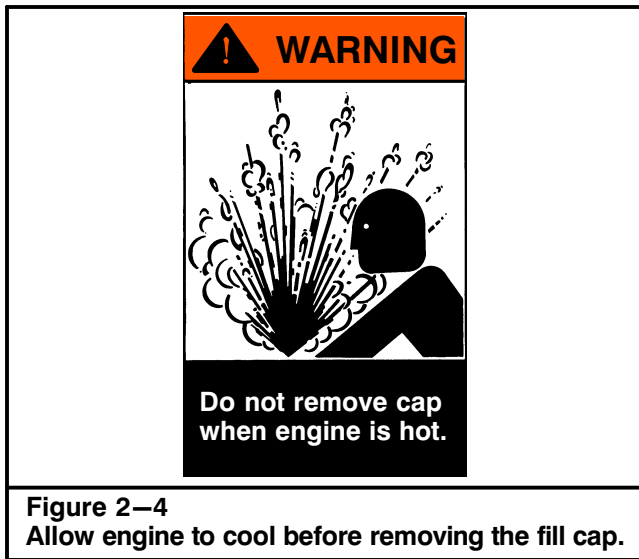

Engine Cooling System

The coolant in the engine cooling system must be maintained at the proper level and proper concentration levels to adequately keep the engine operating at safe temperatures.

Antifreeze must be used in all climates for both freezing and boiling protection. It broadens the operating temperature range by lowering the coolant freezing point and by raising its boiling point. The engine manufacturer recommends extended life coolant (ELC) be used in the cooling system. Refer to engine manufacturer's manual for proper coolant selection.

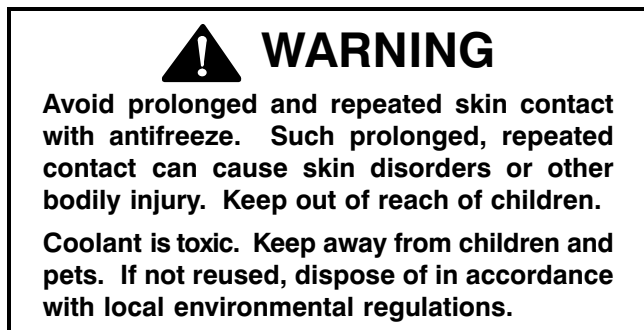

Cooling System Test

Check the glycol (antifreeze) concentration and the freezing point protection as outlined in the engine manufacturer's manual.

Testing the engine coolant is important to ensure that the engine is protected from internal cavitation and from corrosion. Refer to engine manufacturer's manual for additional information on coolant system analysis.

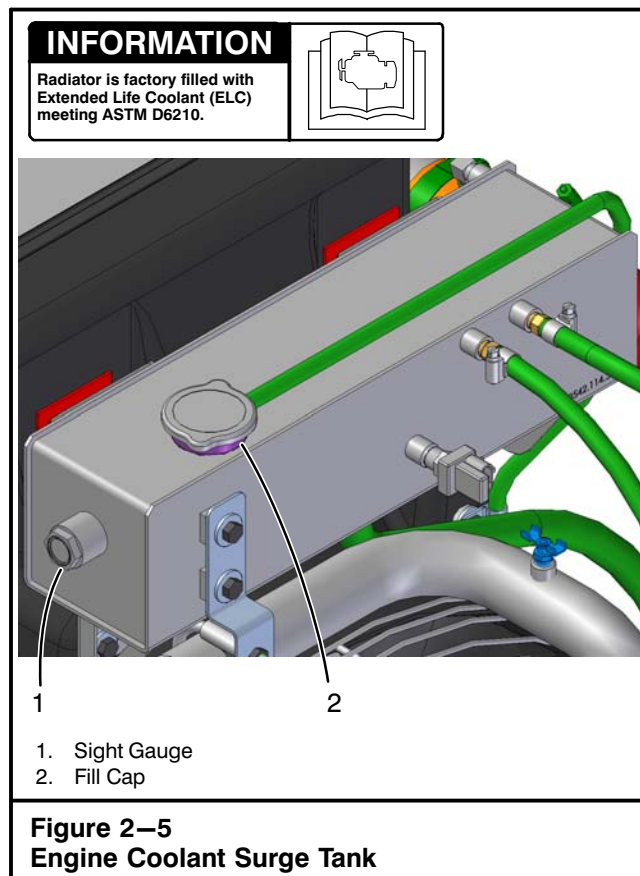

Cooling System Level Check

Check the coolant level in the surge tank every 10 hours of operation. Check the protection level per the maintenance interval schedule in the engine manufacturer's manual.

1. Park the crane on a firm, level surface, shift the transmission to neutral, apply the park brake, and shutdown the engine.
2. Check that the coolant level in the surge tank is visible within the sight gauge on the side of the tank. Refer to Figure 2-5.

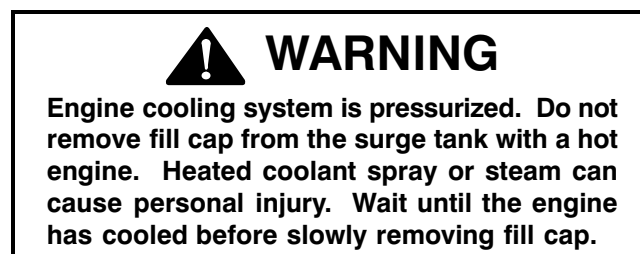

3. If coolant must be added, allow the engine to cool until the the coolant temperature is below 122° F (50° C).

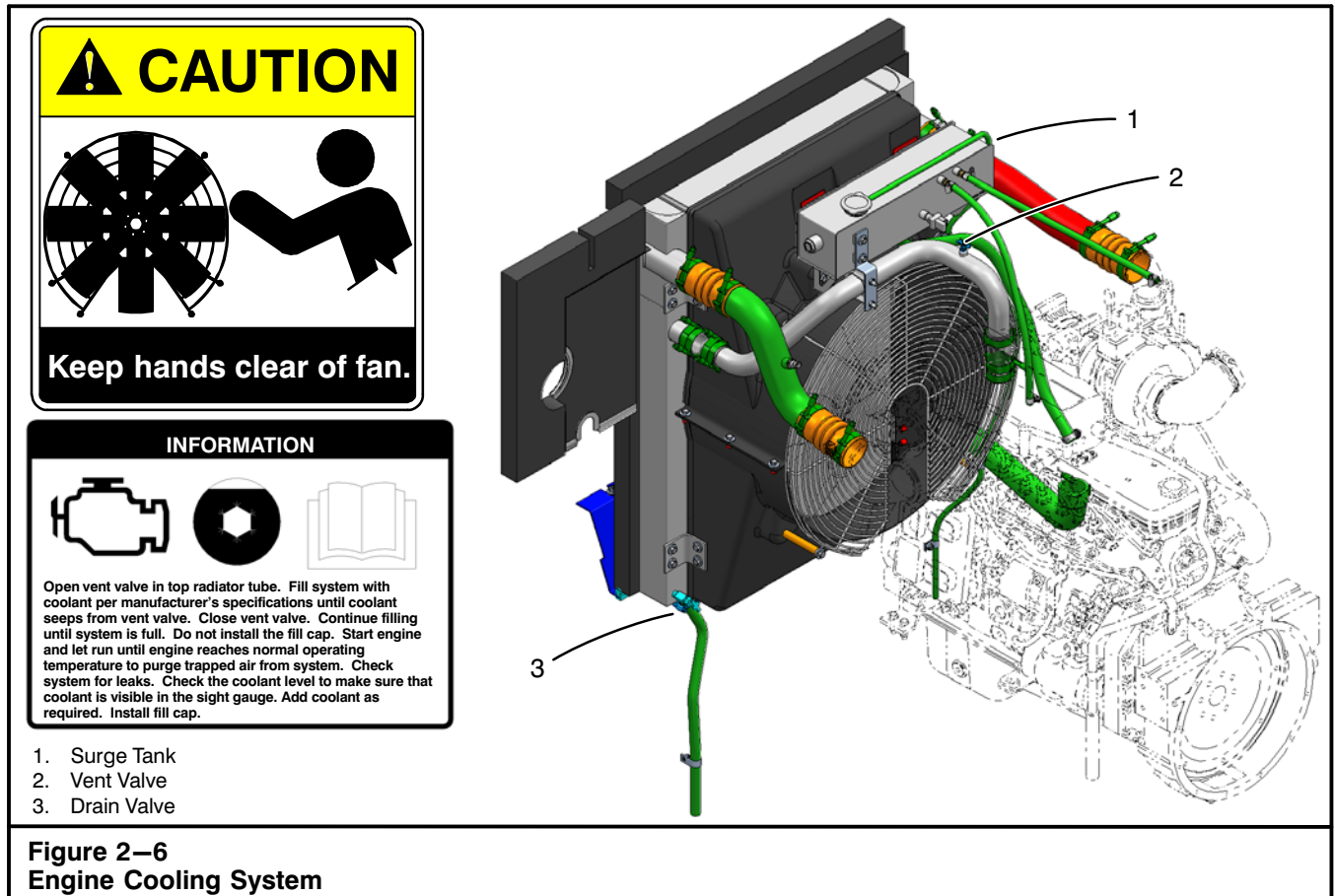

CAUTION

Do not add cold coolant to a hot engine. Engine castings can be damaged. Allow the engine to cool until the coolant temperature is below 122°F (50°C) before adding coolant.

Never use a sealing additive to stop leaks in the cooling system. This can result in cooling system plugging and inadequate coolant flow, causing the engine to overheat.

If additional coolant must be added, it must be pre-mixed before being added to the system. Since the ability of antifreeze to remove heat from the engine is not as good as water, pouring antifreeze into the system first could contribute to an overheated condition before the liquids are completely mixed.

4. Slowly remove the fill cap. Add coolant, as required, until the coolant level in the surge tank is visible within the sight gauge on the side of the tank. Use a pre-mixed solution per the engine manufacturer's specification. Refer to engine manufacturer's manual for proper coolant selection.

Note: There is also a fill level indicator at the bottom of the fill tube inside the surge tank to assist when determining when the proper coolant level is achieved.

5. Replace fill cap. Inspect and clean any debris from the radiator fins.
6. Start the engine and let it run until it reaches normal operating temperature. Shutdown the engine and repeat Step 2.

Operator's Manual

Cooling System Coolant Change

Drain, flush, and fill the engine cooling system at the intervals outlined in the engine manufacturer's manual. Use a pre-mixed solution per the engine manufacturer's specification. Refer to engine manufacturer's manual for proper coolant selection.

CAUTION

Protect the environment: Handling and disposing of used antifreeze is subject to federal, state, and local regulations. Use authorized waste disposal facilities, including civic amenity sites and garages providing authorized facilities for the receipt of used antifreeze. If in doubt, contact your local authorities or the EPA for guidance as to proper handling of antifreeze.

1. Park the crane on a firm, level surface, shift the transmission to neutral, apply the park brake, and shutdown the engine.
2. Allow the engine to cool until the coolant temperature is below 122°F (50°C).



WARNING

Engine coolant may be hot and could cause burns. Avoid prolonged and repeated skin contact with antifreeze. Such prolonged, repeated contact can cause skin disorders or other bodily injury. Keep out of reach of children.

Coolant is toxic. Keep away from children and pets. If not reused, dispose of in accordance with local environmental regulations.

3. Open the vent valve on the top radiator tube. Refer to Figure 2–6. Drain the cooling system by opening the drain valve on the radiator and engine block. Allow the coolant to drain into a suitable container. Properly dispose of used antifreeze.
4. Check for damaged hoses and hose clamps. Hoses must be firm to the feel. If they are soft and spongy they must be replaced. Replace as required. Check the radiator for leaks, damage, and build up of dirt. Clean and replace as required.

5. Inspect and clean any debris from the radiator fins.
6. Close the drain valve on the radiator and engine block.

CAUTION

During filling, air must be vented from the engine coolant passages. Wait 2 to 3 minutes to allow air to be vented. Air trapped in the system may cause damage to the engine.

7. Remove the fill cap from the surge tank.
8. Flush the system as outlined in the engine manufacturer's manual. If the engine is warm, fill slowly to prevent the rapid cooling and distortion of the metal castings.
9. Flush the system as many times as required until the water is clean.
10. Add coolant, as required, until the coolant seeps from the vent valve in the top radiator tube. Close vent valve. Continue filling until coolant level in the surge tank is visible within the sight gauge on the side of the tank. Fill the system with extended life coolant (ELC) per the engine manufacturer's specifications. Refer to engine manufacturer's manual for proper coolant selection. Do not install the fill cap.
11. Start the engine and let it run at low idle. Increase engine to 1,500 rpm. Run the engine until it reached normal operating temperature to purge trapped air from the system. Shutdown the engine.
12. Check the coolant level to ensure that the coolant level is visible within the sight gauge on the side of the tank. Refer to "Coolant System Level Check" in this Section of this Operator's Manual.
13. Install the fill cap on the surge tank.



WARNING

Engine cooling system is pressurized. Do not remove fill cap from the surge tank with a hot engine. Heated coolant spray or steam can cause personal injury. Wait until the engine has cooled before slowly removing fill cap.

14. Start the engine. Check system for leaks and for proper operating temperature.

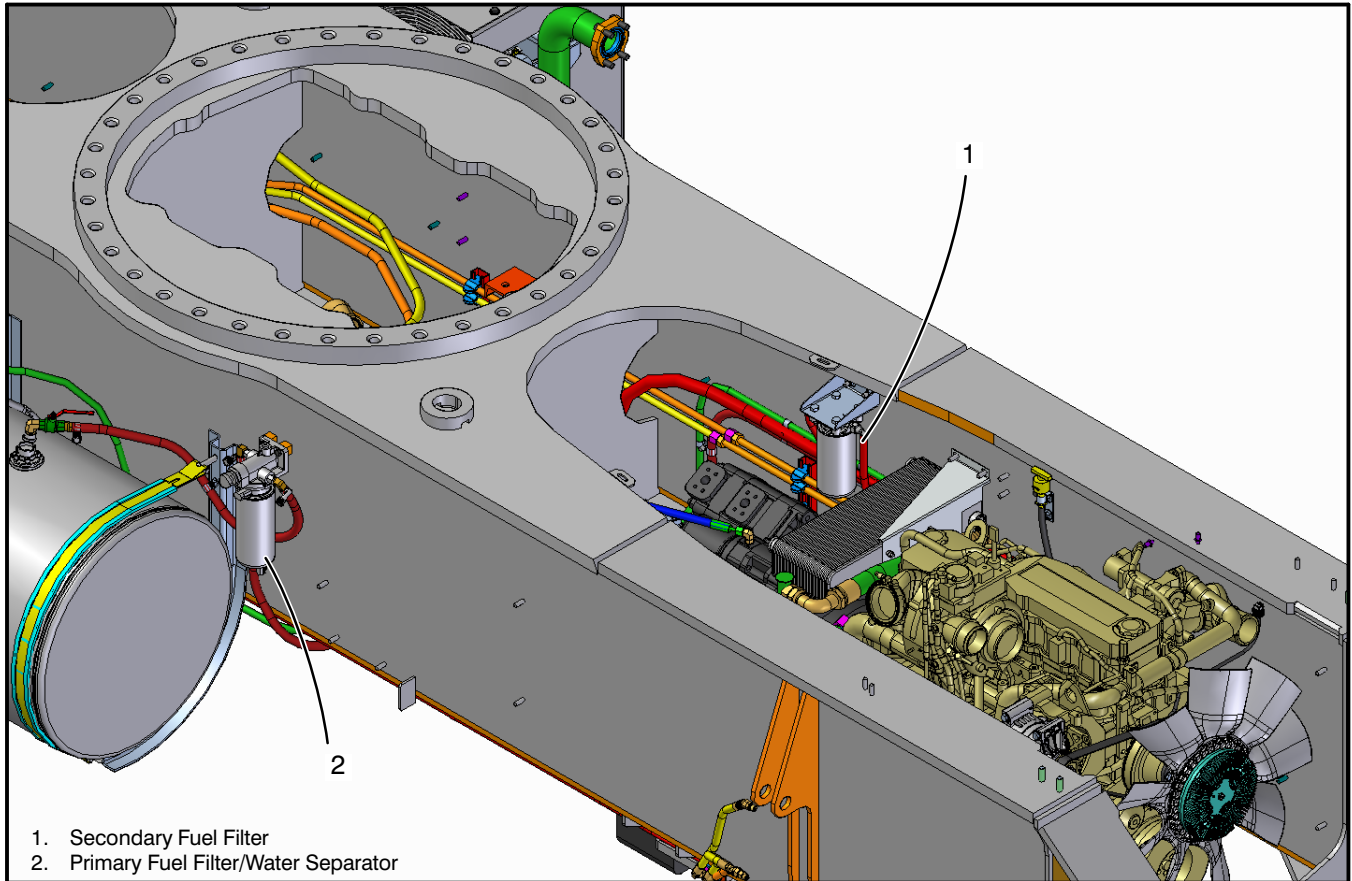

1. Secondary Fuel Filter
2. Primary Fuel Filter/Water Separator

Figure 2-7
Engine Fuel Filters

Engine Fuel Filter

Two spin-on type filters are used, a primary fuel filter/water separator and a secondary fuel filter. (Refer to Figure 2-7.) The function of the filters is to remove water and contaminants from the fuel before they enter the fuel system. Removal of water and contaminants is important for troublefree operation and long life of the fuel system. Water should be drained daily before start-up. Change the filters every 500 hours of operation. Use the following procedures along with Figure 2-8.

Fuel Filter Water Drain

1. Park crane on a firm level surface, engage park brake, shift the transmission to neutral, and shut-down the engine.

CAUTION

The engine must be shutdown when draining water from the fuel filter to prevent water from being drawn into the fuel system.

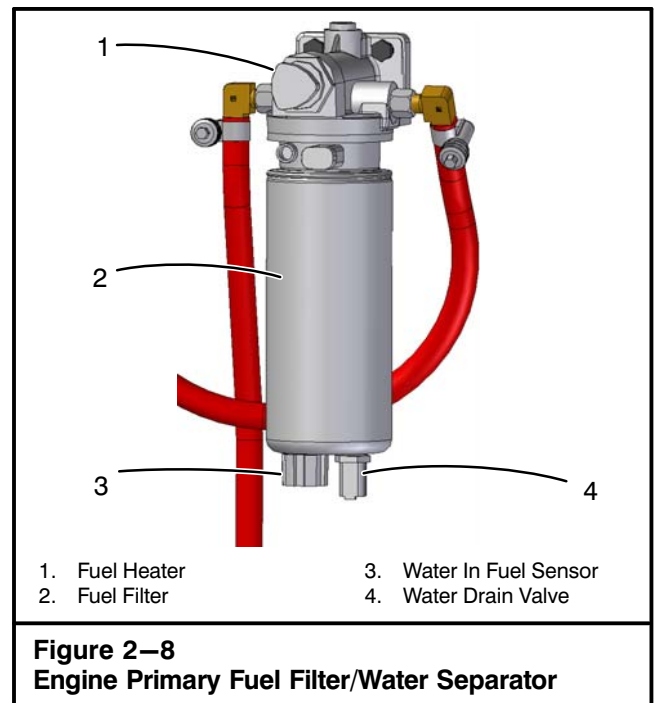

1. Fuel Heater
2. Fuel Filter
3. Water In Fuel Sensor
4. Water Drain Valve

Figure 2-8
Engine Primary Fuel Filter/Water Separator

Operator's Manual

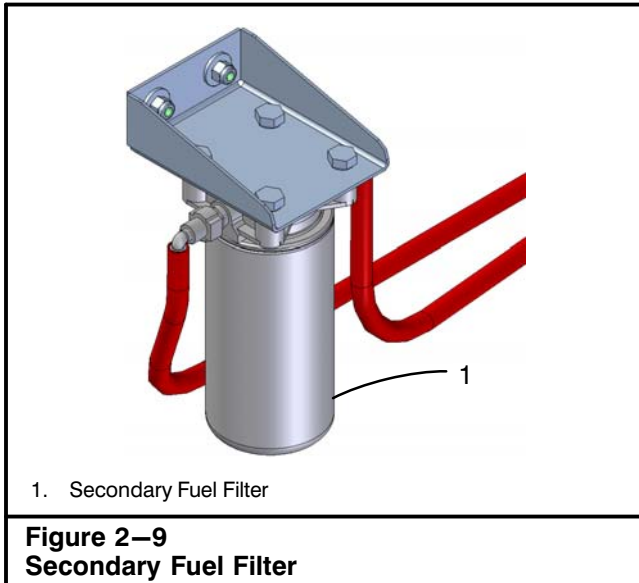

2. Place a suitable container under the drain valve. Turn the drain valve counterclockwise approximately 1 and 1/2 to 2 turns and operate the priming pump until draining occurs.
3. Continue draining until clean fuel is visible.

CAUTION

Do not over-tighten the valve. Over-tightening the drain valve can damage the threads.

4. Close the water drain valve.
5. Properly dispose of contaminated fuel.

Fuel Filter/Water Separator Change

1. Park crane on a firm level surface, engage park brake, shift the transmission to neutral, and shut-down the engine.
2. Clean the area around the filter head.
3. Disconnect the wire harness from the fuel heater and the fuel in water sensor.
4. Place a suitable container under the water drain valve. Open the drain valve. Drain all fuel from filter.
5. Remove the filter from the filter head. Ensure the seal ring does not stick to the filter head.
6. Lubricate a new seal ring with clean engine oil. Install the new filter onto the filter head by hand.

CAUTION

To prevent fuel leaks, confirm that the filter is installed tightly but do not over-tighten. Mechanical tightening will damage the filter.

7. Connect the wire harness to the fuel heater and the fuel in water sensor.
8. Reconnect the engine batteries.
9. Prime the fuel system as follows:
 - a. Turn the ignition key switch to the ON position but do not start the engine. This will cause the ECM to operate the fuel lift pump through a priming cycle which will last at least 30 seconds.
 - b. When the lift pump completes its priming cycle, turn the key to the OFF position for 10 seconds.
 - c. Perform two or three more 30 second lift pump cycles.
10. Start the engine and check for leaks. Slowly increase engine speed to allow air to be purged from the fuel system.
11. Properly dispose of contaminated fuel and filter.

Secondary Fuel Filter Change

1. Park crane on a firm level surface, engage park brake, shift the transmission to neutral, and shut-down the engine.
2. Clean the area around the filter head.
3. Remove the filter from the head.
4. Fill a new filter with clean fuel and thoroughly lubricate the o-ring with clean engine oil.
5. Install new filter on filter head and tighten by hand.

CAUTION

To prevent fuel leaks, ensure the filter is installed tightly but do not over-tighten. Mechanical tightening will damage the filter.

6. Prime the fuel system as follows:
 - a. Turn the ignition key switch to the ON position but do not start the engine. This will cause the ECM to operate the fuel lift pump through a priming cycle which will last at least 30 seconds.
 - b. When the lift pump completes its priming cycle, turn the key to the OFF position for 10 seconds.
 - c. Perform two or three more 30 second lift pump cycles.
7. Start the engine and check for leaks. Slowly increase engine speed to allow air to be purged from the fuel system.
8. Properly dispose of contaminated fuel and filter.

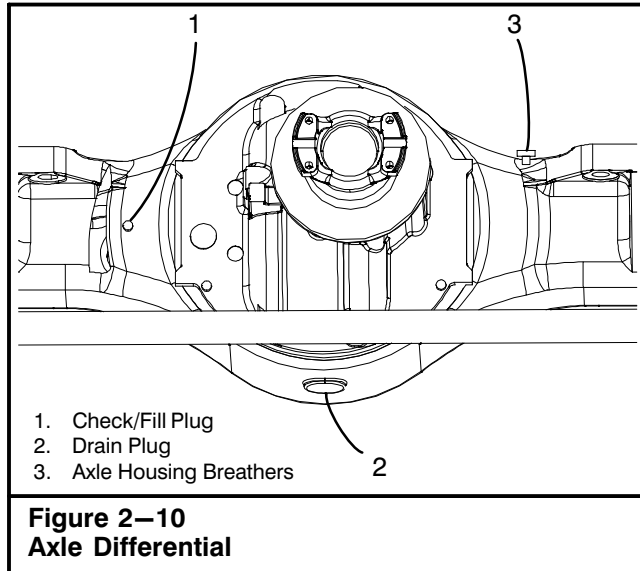

Axle Differentials Lubrication

For troublefree operation, over a period of years, the axle differentials of any crane must be properly lubricated. Check the oil level in each axle differential every 50 hours of operation. The oil in a new or rebuilt axle should be changed after the first 500 hours of operation. Change the oil every 1,000 hours or seasonally thereafter, whichever occurs first.

Axle Differentials Oil Level Check

Check the oil level in both of the axle differentials using the following procedure:

1. Park the crane on a firm level surface, shift the transmission to neutral, engage the park brake, and shutdown the engine.
2. From the underside of the carrier, find the check/fill plug of the differential. Refer to Figure 2-10.
3. Clean the area around the check/fill plug.
4. Remove the check/fill plug and check the oil level. Oil must be level with the bottom of the check/fill hole. Refer to Figure 2-11.
5. Add oil as required, until it begins to flow from the check/fill hole. Refer to Lubrication Chart for correct grade of oil.

Note: The axle manufacturer recommends that types and brands of oil not be intermixed because of possible incompatibility.

6. Clean and install the check/fill plug.
7. Check and clean the axle housing breathers, on the top of the axle housings. Refer to Figure 2-10.

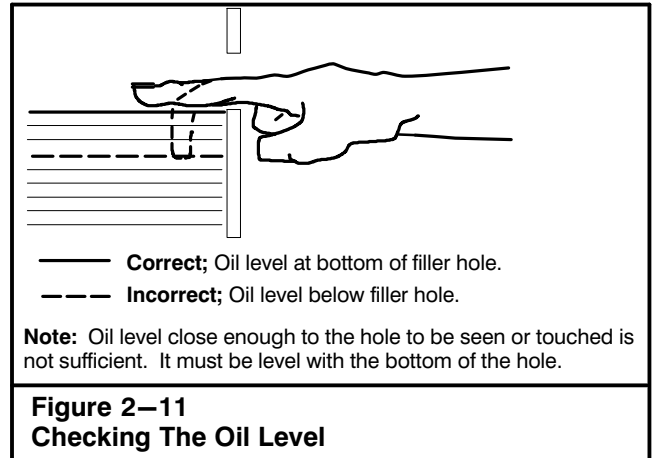

Axle Differentials Oil Change

The best time to change oil in the differentials is immediately after the crane has been driven. At this time, the lubricant will be warm and easily drained. This procedure is especially desirable in cold weather conditions. Change the oil in each of the axle differentials using the following procedure:

1. Park the crane on a firm level surface, shift the transmission to neutral, engage the park brake, and shutdown the engine.
2. Find the drain plug in the bottom of the differential. Refer to Figure 2-10.
3. Clean the area around the drain plug.
4. Remove the drain plug and allow the oil to drain into a suitable container. The drain plug is magnetic and should be inspected for large quantities of metal particles. After the initial oil change, this is a sign of damage or extreme wear within the unit, and a complete internal inspection may be necessary.
5. Clean the drain plug and install it after the oil has thoroughly drained.
6. From the underside of the carrier, find the check/fill plug on the side of the differential. Refer to Figure 2-10.
7. Clean the area around the check/fill plug, and remove it.
8. Fill the differential with oil until it is level with the bottom of the check/fill hole. Refer to Figure 2-11. Refer to the Lubrication Chart for correct quantity and grade of oil.

Note: The axle manufacturer recommends that types and brands of oil not be intermixed because of possible incompatibility.

9. Clean and install check/fill plug.

Operator's Manual

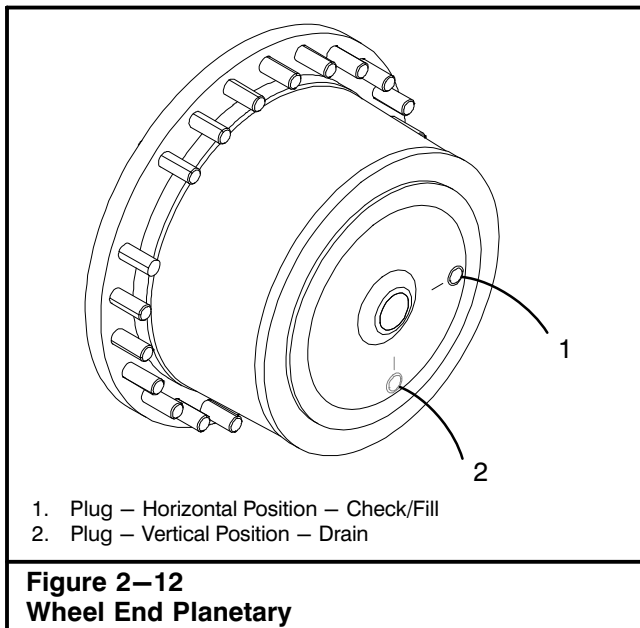

10. Check and clean the axle housing breathers, on the top of the axle housings.
11. Properly dispose of the used oil.

Planetary Wheel End Lubrication

Check the oil level in each wheel end every 50 hours of operation. The oil in a new or rebuilt wheel end should be changed after the first 500 hours of operation. Change the oil every 1,000 hours or seasonally thereafter, whichever occurs first. Use the following procedures to properly lubricate the planetary wheel ends.

Planetary Wheel End Oil Level Check

1. Park the crane on a firm level surface, shift the transmission to neutral, and apply the park brake.
2. Properly level the crane on outriggers, disengage the park brake, and shutdown the engine.
3. Rotate the wheel end until the line next to the check/fill/drain plug is in the horizontal position. Refer to Figure 2-12.
4. Clean the area around the check/fill/drain plug to prevent foreign material from entering the wheel end.
5. Remove the check/fill/drain plug and check the oil level. Oil should be level with the bottom of the hole. Refer to Figure 2-11.
6. Add oil as required until it begins to flow from the hole. Refer to the Lubrication Chart for the correct grade of oil.

Note: It is recommended that types and brands of oil not be intermixed because of possible incompatibility.

7. Clean and install the check/fill/drain plug.

8. Repeat Steps 3 through 7 for the other planetary wheel ends. Apply the park brake before lowering the crane from the outriggers.

Planetary Wheel End Oil Change

Perform the following procedure on all of the planetary wheel ends simultaneously to minimize the time spent to change the oil.

1. Drive the crane for 5 minutes to agitate and warm the oil.
2. Park the crane on a firm, level surface, shift the transmission to neutral, and apply the park brake.
3. Properly level the crane on outriggers, disengage the park brake, and shutdown the engine.
4. Rotate the wheel ends until the line next to the check/fill/drain plug is in the vertical position with the line pointing down. Refer to Figure 2-12.
5. Clean the area around the check/fill/drain plug to prevent foreign material from entering the wheel end.
6. Remove the check/fill/drain plug and allow the oil to drain into a suitable container.



WARNING

Oil draining from the planetaries may be hot and could cause severe burns. Use caution when removing the plugs.

7. After thoroughly draining the oil, the wheel ends should be flushed.
 - a. Rotate the wheel ends until the line next to the plug is in the horizontal position.
 - b. Fill the wheel ends with a light flushing oil or kerosene and install the check/fill/drain plug.
 - c. Operate the wheel ends for a short period of time at a very low speed.
 - d. Rotate the wheel ends until the line next to the check/fill/drain plug is in the vertical position with the line pointing down.
 - e. Remove the check/fill/drain plugs and allow all the flushing solution to drain into a suitable container.
8. Rotate the wheel ends until the line next to the check/fill/drain plug is in the horizontal position.
9. Fill the wheel ends with oil until it begins to flow from the check/fill/drain hole. Refer to Figure 2-11. See the Lubrication Chart for the correct grade and quantity of oil.

Note: It is recommended that types and brands of oil not be intermixed because of possible incompatibility.

10. Clean and install the check/fill/drain plugs.
11. Properly dispose of used oil and flushing solution.

Wheel Bearing Lubrication

Under normal operating conditions, the axle wheel bearings are lubricated by oil in the planetary wheel ends. In short, as long as the axle planetaries are operating with the proper oil levels, and using the correct grade of oil, the wheel bearings are properly lubricated.

Hydraulic Reservoir

The hydraulic reservoir is used to supply and store hydraulic oil needed to operate all hydraulic functions of the crane. The hydraulic reservoir, as shown in Figure 2–13, is equipped with a sight gauge for checking the oil level.

A filter housing is mounted on the top of the reservoir. It has a contamination indicator which signals when the filter is being bypassed. Drain any water from the hydraulic reservoir, check the oil level, and inspect the contamination indicator daily. Operating the crane with the oil level below the full mark or with the filter element bypassed can lead to hydraulic component failure. Refer to the following procedures when servicing the hydraulic reservoir.

Water Drain

Drain the water from the hydraulic reservoir daily before start-up. Contaminated oil will damage the systems hydraulic components.

1. Relieve any trapped hydraulic system pressure by loosening the filler/breather cap, on the hydraulic reservoir, 1/4 turn until pressure is fully relieved. Refer to Figure 2–13.



WARNING

All trapped hydraulic pressure must be exhausted from the system before removing any plug or cover. A sudden release of hot oil could cause burns or other serious injury.

2. Loosen the water drain plug and allow the water to drain into a suitable container. The water drain plug is slotted and need not be completely removed to drain the water.
3. When a clean flow of hydraulic oil begins to drain from the water drain plug, tighten the plug.
4. Check the oil level in the hydraulic reservoir before beginning operation of the crane. Add oil if necessary. Use only Hi Performance Hydraulic Oil or an approved substitute. Properly dispose of the contaminated water.

Hydraulic Reservoir Oil Level Check

1. Park the crane on a firm, level surface, shift the transmission to neutral, and apply the park brake. Fully retract all hydraulic cylinders and shutdown the engine.
2. With the hydraulic oil cold (approximately 62°F / 17 °C), check its level through the sight gauge on the front of the hydraulic reservoir. Refer to Figure 2–13. The proper level must be maintained at all times. Add hydraulic oil as necessary to bring the oil level between the “ADD” and “FULL” marks. Use only Hi Performance Hydraulic Oil or an approved substitute. Do Not Overfill.

Adding Oil To The Hydraulic Reservoir

1. Park the crane on a firm, level surface, shift the transmission to neutral, and apply the park brake. Fully retract all hydraulic cylinders and shutdown the engine.
2. Relieve any trapped hydraulic system pressure by loosening the filler/breather cap, on the hydraulic reservoir, 1/4 turn until pressure is fully relieved. Refer to Figure 2–13.



WARNING

All trapped hydraulic pressure must be exhausted from the system before removing any plug or cover. A sudden release of hot oil could cause burns or other serious injury.

3. Clean the top of the hydraulic reservoir, the filter housing, and filler breather cap to prevent foreign material from entering the hydraulic system.
4. Remove the filler breather cap.
5. Add oil as required. Use only Hi Performance Hydraulic Oil or an approved substitute. Check the oil level.
6. Install filler breather cap.

Hydraulic Reservoir Filter Change

Change hydraulic reservoir filter element after the initial 50 hours of operation and every 500 hours of operation thereafter. Change the filter element immediately if the contamination indicator needle is in the red area.

1. Park the crane on a firm, level surface, shift the transmission to neutral, and apply the park brake. Fully retract all hydraulic cylinders and shutdown the engine.
2. Relieve any trapped hydraulic system pressure by loosening the filler breather cap, on the hydraulic reservoir, 1/4 turn until pressure is fully relieved. Refer to Figure 2–13.

Operator's Manual

TO CHECK OIL LEVEL

Check level when oil is cold (approx. 62°F) or (17°C) with engine off, machine level, and all cylinders fully retracted.

———— FULL

———— ADD

INFORMATION

Oil level must be maintained between "FULL" and "ADD" marks at all times. Operation of machine with oil level below "ADD" will contribute to pump failure. Do not overfill.

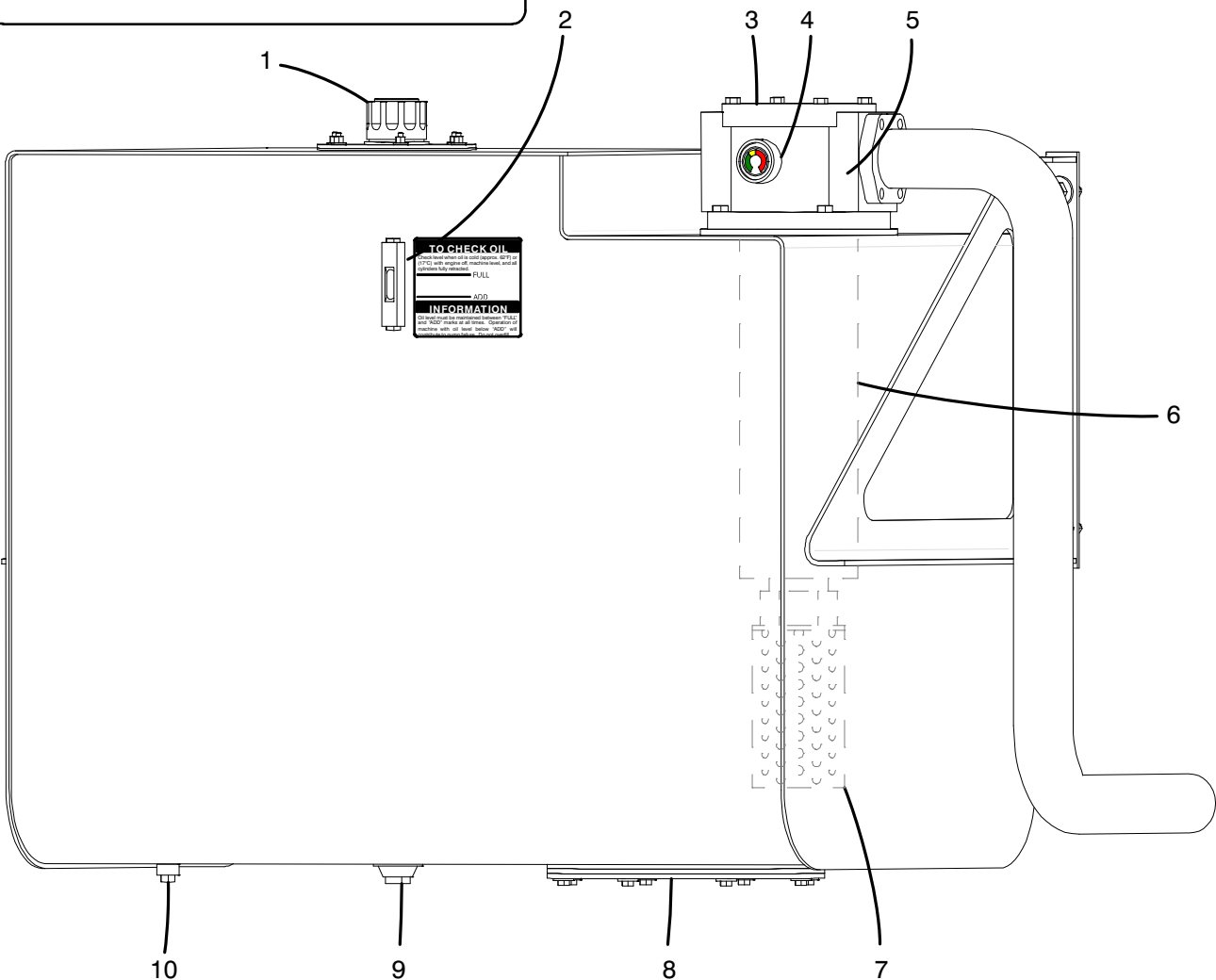

- | | | |
|----------------------------|-------------------|------------------------|
| 1. Filler Breather Cap | 5. Filter Housing | 8. Bottom Access Panel |
| 2. Sight Gauge | 6. Element | 9. System Drain Plug |
| 3. Filter Housing Cover | 7. Oil Diffuser | 10. Water Drain Plug |
| 4. Contamination Indicator | | |

Figure 2-13
Hydraulic Reservoir

Operator's Manual



WARNING

All trapped hydraulic pressure must be exhausted from the system before removing any plug or cover. A sudden release of hot oil could cause burns or other serious injury.

3. Clean the top of the hydraulic reservoir, the filter housing, and filter housing cover to prevent foreign material from entering the hydraulic system.
4. Remove the filter housing cover. Refer to Figure 2–13.
5. Remove the filter element and inspect it for contamination. Any dirt or foreign particles on the filter element may indicate excessive system contamination or imminent system component failure. Once the filter has been thoroughly inspected, dispose of it properly.
6. Install new filter element and filter housing cover.
7. Start engine and check the filter housing for leaks.
8. Check the hydraulic reservoir oil level. Add oil if necessary. Use only Hi Performance Hydraulic Oil or an approved substitute.

Hydraulic Reservoir Oil Change

The hydraulic reservoir oil should be changed every 2,000 hours of operation or seasonally, whichever occurs first. Change the hydraulic reservoir oil at the end of a working day when any foreign particles will be suspended in the warm oil. If this is not possible, cycle the crane until the oil is warm and proceed as follows:

1. Park the crane on a firm, level surface, shift the transmission to neutral, and apply the park brake. Fully retract all hydraulic cylinders and shutdown the engine.
2. Relieve any trapped hydraulic system pressure by loosening the filler breather cap, on the hydraulic reservoir, 1/4 turn until pressure is fully relieved. Refer to Figure 2–13.



WARNING

All trapped hydraulic pressure must be exhausted from the system before removing any plug or cover. A sudden release of hot oil could cause burns or other serious injury.

3. Thoroughly clean the exterior surface of the hydraulic reservoir to prevent foreign materials from entering the system, once the access panels and filter housing are opened.
4. Remove the filler breather cap and pump the hydraulic oil into suitable containers. Refer to the Lubrication Chart to determine the volume of oil to be removed.

Note: If a pump is not available to remove the oil from the reservoir, place a suitable container under the system drain plug. Open the plug and drain one container full at a time, until the oil has thoroughly drained from the reservoir. Do not remove bottom access panel to drain reservoir.



WARNING

Do not remove the bottom access panel before the hydraulic reservoir has completely drained. A large volume of hot oil may suddenly be released resulting in serious personal injury and/or property damage. Drain the oil from the hydraulic reservoir before removing the bottom access panel.

5. Remove the system and water drain plug.
6. Remove the bottom access panel, filter housing cover, and the filter element. Properly dispose of the filter element.
7. Clean any old gasket material from the access panel and hydraulic reservoir.
8. Remove and clean the oil diffuser in the bottom of the filter housing.
9. Clean the interior of the hydraulic reservoir with clean diesel fuel or kerosene.
10. Allow the diesel fuel or kerosene to drain into a suitable container until the hydraulic reservoir is thoroughly drained. Inspect the interior of the hydraulic reservoir for foreign material and wipe clean.
11. Clean and install the system and water drain plug.
12. Clean the filter housing. Install oil diffuser in the bottom of filter housing. Install a new filter element.
13. Install the access panel using new gasket.
14. Using clean, uncontaminated Hi Performance Hydraulic Oil or an approved substitute, fill the reservoir through the filter element until it reaches the full mark by the sight plugs.
15. Install the filter housing cover.
16. Engage the main pump and start the engine. Allow the engine to idle several minutes to ensure oil is being cycled properly. Check for any leaks.
17. Check the oil level in the hydraulic reservoir for proper level. Add oil if necessary. Use only Hi Performance Hydraulic Oil or an approved substitute. Properly dispose of the used oil.

Note: In case of hydraulic system component failure, a more thorough oil change procedure is required. Contact a Link-Belt Distributor for this procedure.

Operator's Manual

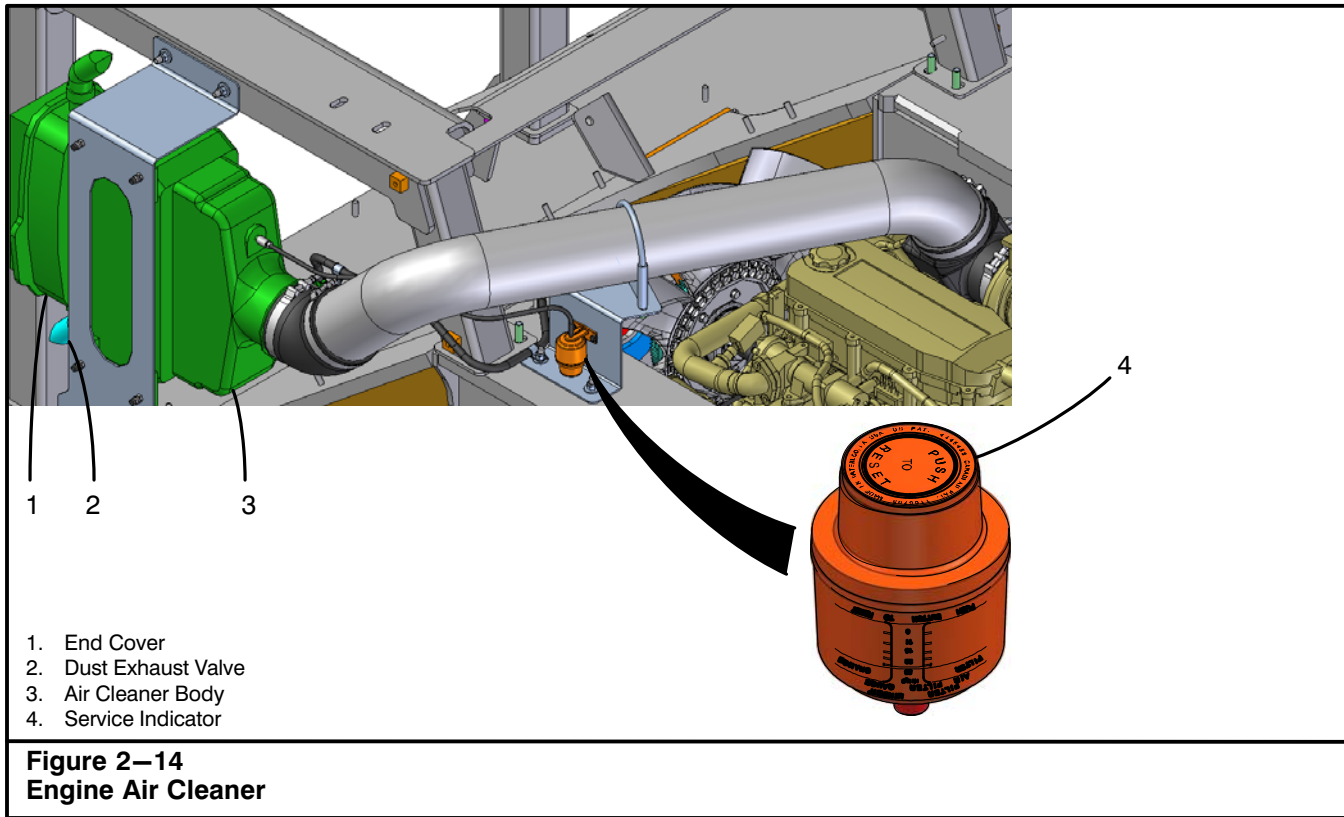

Engine Air System Inspection

It is recommended that the engine air system be inspected every 250 hours or 6 months. Inspect the air system pipes, hoses, and turbocharger systems, as equipped. (Inspect all the pipes and hoses associated with the turbocharger, air cleaner, and air intake.) Check for any cracks, corrosion, loose clamps, wear points, leaks, or punctures which can allow contaminants to enter the system and damage air system components and/or the engine. All hoses should be kept free of oil contaminants, both internally and externally. Disassemble and clean as required. Tighten or replace parts as necessary to ensure that the air system does not leak.

Engine Air Cleaner

Variations in job site conditions prevent establishing a set interval for air cleaner servicing. For this reason a vacuum operated service indicator is mounted on an air tube, inside the engine hood, to assist in determining the condition of the air cleaner element. Refer to Figure 2–14. Check the service indicator daily. Anytime the yellow indicator reaches the filter change (red) line, service the air cleaner immediately. Clean or replace the air cleaner element as often as required.

Replace the air cleaner element after it has been cleaned six times or annually, whichever occurs first.

Changing The Air Cleaner Element

1. Park the crane on a firm level surface, shift the transmission to neutral, engage the park brake, and shutdown the engine.
2. Inspect the service indicator (Figure 2–14) to see if the yellow indicator has reached the filter change (red) line. If the yellow indicator has reached the filter change (red) line, proceed with the following steps. If it has not reached the red line, there is no reason to service the air cleaner. Over servicing the air cleaner will shorten the life of the element and unnecessarily increase downtime.
3. Remove the end cover from the air cleaner body.
4. Remove element from air cleaner body.
5. Remove the dust exhaust valve and inspect it for damage or wear. Replace it if required.
6. Wipe the inside of the air cleaner body clean using a damp cloth. Install the dust exhaust valve.
7. Slide the new element into the air cleaner body.
8. Install the end cover to the air cleaner body.
9. Reset the service indicator (Figure 2–14) by pressing the reset button on the end of it.

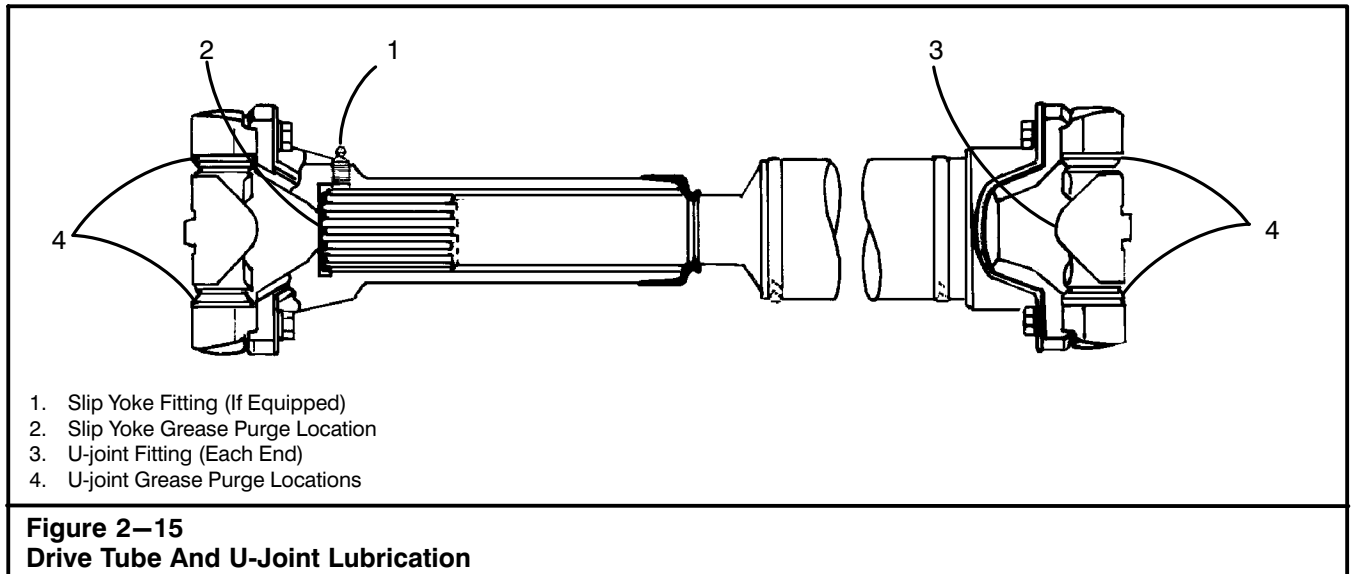

Drive Tube And U-Joint Lubrication

Drive tubes and u-joints are used to transmit torque from one drive line component to another. They also help absorb shock loadings. Because they are so critical to crane operation, thorough lubrication is necessary. Use the following procedure to lubricate the drive tubes and u-joints every 50 hours of operation.

1. Park the crane on a firm level surface, shift the transmission to neutral, engage the park brake, and shutdown the engine. Follow Steps 2 through 7 on each drive tube.
2. Check the slip yoke for looseness or side play.

3. Apply grease through the fitting (if equipped) at the slip yoke until all the old grease is purged from the slip yoke. Refer to Figure 2–15 for grease fitting locations.
4. Check each u-joint for looseness.
5. Apply grease through the fitting on each u-joint until all the old grease is purged. Purging should occur at all four seals on each u-joint. Refer to Figure 2–15 for grease fitting locations.
6. If grease does not purge from each seal, manipulate the u-joint until purging occurs.
7. If the above is not successful, remove the u-joint and inspect it. If the grease is rusty, gritty, or burnt, replace the u-joint.

Operator's Manual

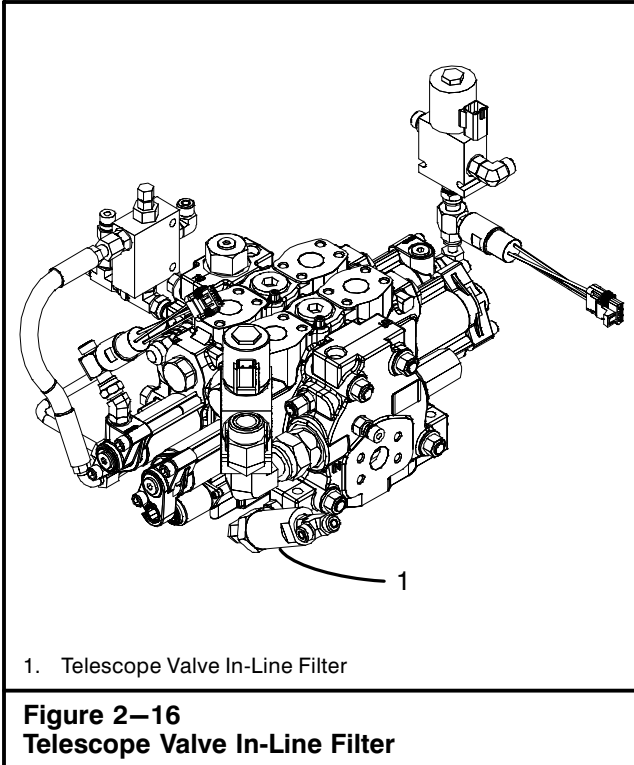

Telescope Valve In-Line Filter Cleaning

Clean or change telescope valve in-line filter element after every 500 hours of operation.

1. Park the crane on a firm level surface, engage park brake, shift the transmission to neutral, and shut-down the engine.
2. Relieve any trapped hydraulic system pressure by working the control levers in the operator's cab back and forth.
3. Release any residual pressure in the hydraulic reservoir by slowly loosening the filler/breather cap until pressure is fully relieved.



WARNING

All trapped hydraulic pressure must be exhausted from the system before removing any plug or cover. A sudden release of hot oil could cause burns or other serious injury.

4. Clean the area around the telescope valve in-line filter to prevent foreign material from entering the hydraulic system. Refer to Figure 2–16.
5. Remove element from filter body and inspect it for contamination.
6. Clean element with solvent, back flushing, or ultrasonic cleaning. Replace if required.
7. Install element in filter body.
8. Start engine and check for leaks.

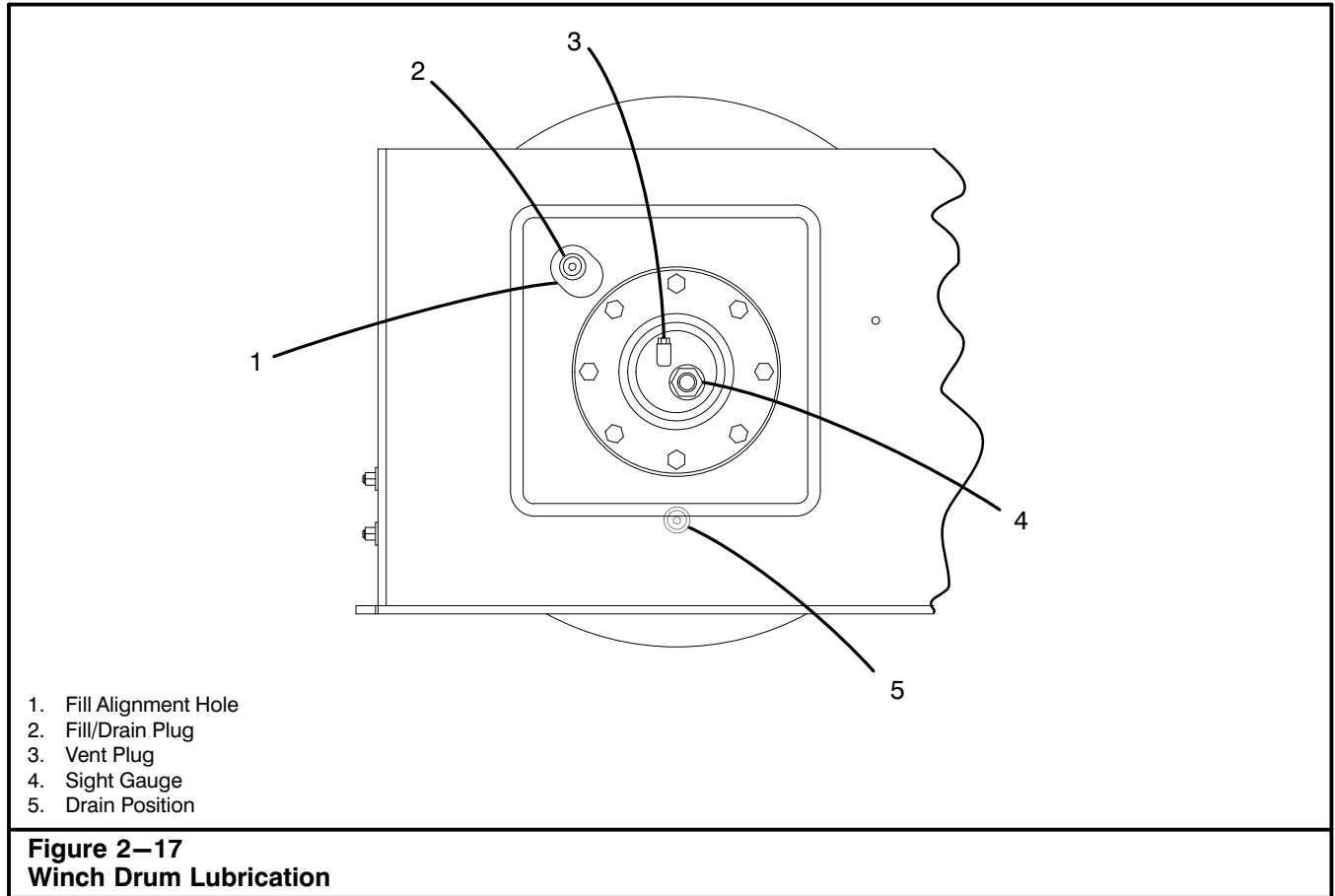

Winch Drum(s) Lubrication

For maximum operating efficiency and service life of the winch drum(s), check oil level after every 50 hours of operation. The oil, in a new or rebuilt winch drum, should be changed after the initial 100 hours of operation. Thereafter, change oil with each 1,000 hours of operation or seasonally, whichever occurs first. It is also recommended that every 2,000 hours of operation, the winch(es) should be disassembled and thoroughly inspected for damaged or worn parts. Replace damaged or worn parts as required.

Winch Drum Oil Level Check

1. Park the crane on a firm, level surface, shift the transmission to neutral, apply the park brake, and shutdown the engine.
2. Observe the oil level within the sight gauge. Oil should be visible within the sight gauge. Refer to Figure 2–17.

Winch Drum Oil Change

1. Park the crane on a firm level surface, shift the transmission to neutral, engage the travel swing lock, and apply the park brake.

2. Cycle the winch for several minutes, without a load to agitate and warm the oil within the winch drum.
3. Rotate winch drum until the fill/drain plug is aligned with the fill alignment hole in the side support. Refer to Figure 2–17.
4. Shutdown the engine.
5. Thoroughly clean the exterior surface of the winch around the vent and fill/drain plugs to prevent contamination from entering the unit.
6. Remove the fill/drain and vent plugs.
7. Position a suitable container under the winch drum.
8. Start the engine. Rotate the drum until the fill/drain port is in the drain position. Shutdown the engine and allow the oil to drain into a suitable container.
9. After the oil has thoroughly drained, start the engine and rotate the drum until the fill/drain port is aligned with the fill alignment hole in the side support. Shutdown the engine.
10. Fill the unit with oil through the fill/drain port, until oil is visible within the sight gauge. For the correct grade and quantity of oil, refer the Lubrication Chart.
11. Clean and install the vent and fill/drain plugs. Properly dispose of the used oil.

Operator's Manual

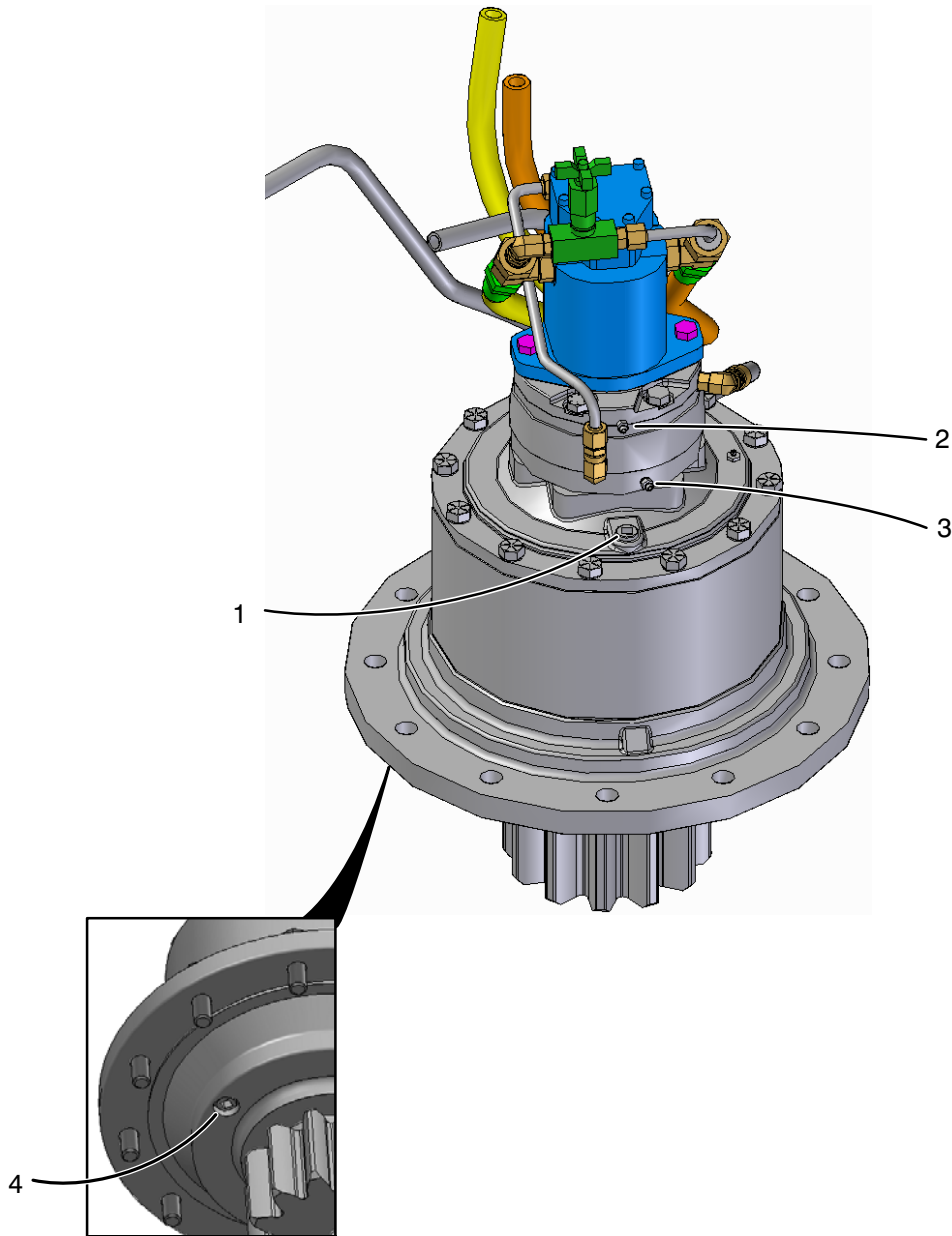

- 1. Swing Unit Check/Fill Plug
- 2. Swing Park Brake Bleeder

- 3. Service Brake Bleeder
- 4. Swing Unit Drain Plug

Figure 2–18
Swing Speed Reducer And Brake

Swing Speed Reducer Lubrication

Check the oil level in the swing speed reducer after every 50 hours of operation. The oil in a new or rebuilt swing speed reducer should be changed after the initial 200 hours of operation. Thereafter, change the oil with each 1,000 hours of operation or seasonally, whichever occurs first.

Swing Speed Reducer Oil Level Check

1. Park the crane on a firm, level surface. Shift the transmission to neutral, and engage the park brake.
2. Engage the travel swing lock and shutdown the engine. Refer to Figure 2–18.
3. Clean the speed reducer around the check/fill plug to prevent contamination from entering the system. Remove the check/plug.
4. Oil should be within 0.25 in (6mm) of the bottom of the threads. Add oil as required to bring the oil to the proper level. Refer to the Lubrication Chart for the correct grade of oil.
5. Clean and install the check/fill plug.

Swing Speed Reducer Oil Change

1. Park crane on a firm, level surface, shift the transmission to neutral, and engage the park brake.
2. Level the crane on fully extended outriggers and swing the upper for several minutes, to agitate and warm the oil within the swing speed reducer.
3. Engage the travel swing lock, fully lower the boom, and shutdown the engine.
4. Thoroughly clean the exterior surface of the swing speed reducer around the check/fill and drain plugs to prevent contamination from entering the unit. Refer to Figure 2–18.
5. Remove the check/fill and drain plugs and allow the oil to drain into a suitable container. The drain plug is magnetic and should be inspected for large quantities of metal particles. After the initial oil change, this is a sign of damage or extreme wear within the unit, and a complete internal inspection may be necessary.
6. After the oil has thoroughly drained, clean and install the drain plug.
7. Fill the unit with oil through the check/fill hole, until the oil is within 0.25 in (6mm) of the bottom of the hole. For the correct grade and quantity of oil, refer to the Lubrication Chart.
8. Clean and install the check/fill plug. Properly dispose of the used oil.

Operator's Manual



Figure 2–19
Do not climb on boom or attachments.

Boom Inspection & Lubrication



The boom wear shoes are equipped with teflon inserts that self-lubricate the boom sliding surfaces. Therefore, the boom sliding surfaces require no lubrication. However, visually inspect all boom sections daily for damaged or cracked members or welds. If any dents, bends, cracked welds, etc. are found, do not use the crane. Contact a Link-Belt Distributor for repair procedures. Also check for damaged or leaking hoses, fittings, valves, cylinders, etc. Repair as necessary. At 250 hour intervals, check all boom wear shoes for proper adjustment. See "Boom Wear Shoe Adjustment" in Section 3 of this Operator's Manual for further details. Inspect the wire rope deflector bar at the top front of each boom section, for wear. Reverse or replace as required.

To prevent movement of the individual boom sections, shutdown the engine and ensure that the operator has vacated the operator's cab before putting your hands or tools inside the boom. Unexpected movement of the boom section could sever fingers, hands, arms, etc.

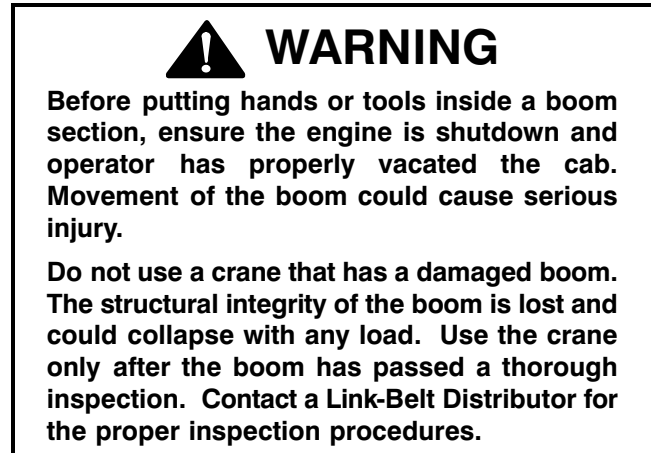

Lubricate the boom locking pins, boom head sheaves, and auxiliary head sheaves if equipped, every 50 hours of operation.

Fly Inspection & Lubrication

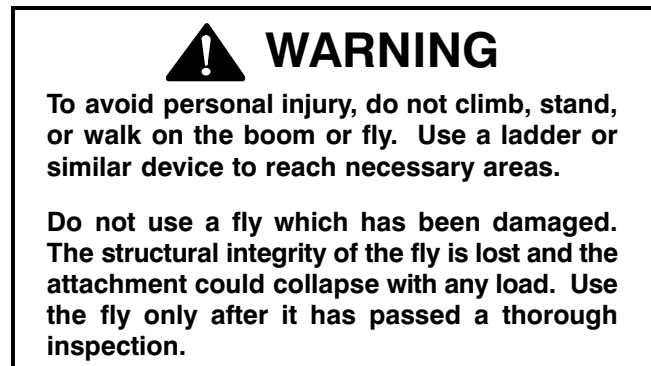

Inspect all parts of the fly daily. Pay particular attention to the chords and lattice. If any dents, bends, cracked welds, etc. are found, do not use the fly. Contact a Link-Belt Distributor for repair procedures.

Lubricate the fly head sheaves and deflector sheave(s) every 50 hours of operation.

Wire Rope Lubrication

Inspect wire ropes daily to ensure they are not damaged.

Wire rope is like a machine. Each time a wire rope bends over a sheave or straightens from a slack position many wires move against each other. Lubrication is necessary to help prevent wear caused by this movement. Lubrication also helps prevent deterioration of wire rope due to rust and corrosion.



WARNING

Rusty wire rope is dangerous since there is no way to determine its remaining strength. Do not use rusty wire rope.

Most wire ropes are lubricated during manufacture, but the lubricant does not last the life of the wire rope. The lubricant is squeezed out of the wire rope as it runs over sheaves under tension, or is washed off by rain.

For the above reasons, wire rope **MUST BE** periodically lubricated. Crude or used oils and grease should not be used as lubricants because they may be grit or acid laden. Either of these conditions can cause damage to the wire rope.

No set rule can be given for lubrication frequency. This will depend on the type of conditions under which the wire rope is used.

A wire rope used in wet conditions would need to be lubricated more often than one used in dry conditions, to prevent rust and corrosion.

Lubricants used for wire rope lubrication should have the following properties:

1. They must have enough adhesive strength to stay on the wire rope.
2. They must be able to penetrate between the wires and strands.
3. They must have high film strength.
4. They must resist oxidation.
5. They must remain soft and pliable.

Application Of Wire Rope Lubricant

Wire ropes that have been in service should be cleaned before re-lubricating them. Use a wire brush and compressed air to clean the wire rope. All possible foreign material and old lubricant should be removed from the wire rope before re-lubricating it. Use one of the following methods to apply the lubricant.

1. Continuous Bath

Run the wire rope through a container filled with lubricant. A sheave mounted in the center of the container will hold the wire rope submerged as it passes through the container. Use swabbing to remove excess lubricant as the wire rope leaves the container.

2. Dripping

Place a container above a sheave so a spigot can be opened to drip oil on the wire rope as it passes through the sheave groove.

3. Swabbing And Painting

Two fast methods are swabbing the lubricant on with rags or painting it on with a brush.

4. Spraying

Light lubricants may be applied with a spray gun. Aerosol cans of lubricant are also available.

Operator's Manual

Hook Block, Hook Ball, And Swivel Inspection And Maintenance

1. All nuts, setscrews, pins, bolts, and retainers should be checked for tightness every 14 to 30 days, depending on the operating conditions and the product involved.
2. Inspect the components carefully at least once a month.

Swivels: Check for excessive gap distance between the rotating parts. Check threaded parts that are installed together to see that they are secure and tight. Check all setscrews to see that they are tight and staked.

Hook Blocks: Check all pins and bolts for tightness, spreading of side plates, weld cracks, sheave wear, bearing wear, spreading of hook, and

that setscrews are tight and staked. Check that hook latch is operative.

Hook Balls: Check pin, nut, and washer to ensure ball halves are held securely together. Check locating pin for excessive wear. Inspect swivel parts as specified previously. Check that hook latch is operative.

3. If a swivel is constantly overloaded, it will cause damage to the unit. The first sign of damage is often bearing brinelling (dimpling of the bearing races). This condition is determined by spinning the swivel by hand. If the motion is rough or has a ratchet-like effect, the bearing has been damaged and should be replaced.
4. The distance between the swivel barrel and shank or rotating members are pre-set with a factory clearance of 0.020–0.050 in (0.5–1.2mm). If this distance increases more than 0.060 in (1.5mm) over the above distance, it is a good indication of bearing fatigue and the unit should be removed from service.

| Item | Under Intermittent Operating Conditions | Under Continuous Operating Conditions |
|--|---|---------------------------------------|
| Swivels, Swivel Overhaul Balls, Swivel Balls | 14 days | 24 hours |
| Blocks with Bronze Bushed Sheaves | 14 days | 8 hours |
| Blocks with Roller Bearing Sheaves | 14 days | 24 hours |

Chart A – Hook Block, Hook Ball, & Swivel Lubrication Frequency

| Item | Frequency | What to Check For | Appropriate Action |
|------------|--|--|---|
| Swivels | 14 days under continuous operation 30 days under intermittent operation | End play or gap of more than 0.06 in (1.5mm) along the axis. | Remove from service immediately. |
| | | Rough turning. | Defective bearing. Remove from service immediately. |
| | | Elongated eye holes, bent clevis pins. | Indicates overload. Remove for repairs. |
| Sheaves | 14 days under continuous operation 30 days under intermittent operation | Misalignment, as evidenced by wobble or uneven groove flange wear. | Indicates severe bearing wear. Remove from service. Check for wear in bronze spacers where used. |
| | | Striations or corrugations in sheave groove. | Result of wire rope wear. If serious, replace. |
| Hook Latch | When Used | Missing, off center, bent, broken spring, or defective. | Replace immediately |
| Hooks | Daily or When Used | Permanent deformation or stretching. | An indication of overload. If serious, replace. Any suspicion of fractures calls for an immediate investigation and, if necessary, replacement of part. |
| | | Crack or other defects. | Hooks should be tested at least once a year by magnafluxing, x-ray, or other qualified method. Intermittent tests can be conducted by a less accurate oil stain method. |

Chart B – Hook Block, Hook Ball, & Swivel Inspection Frequency

Turntable Bearing Capscrew Torque

Maintaining the proper torque on turntable bearing mounting capscrews is critical. If the bearing has been replaced or the crane undecked for any reason, capscrews should be replaced. Reuse of turntable bearing mounting capscrews is not recommended.

Turntable Bearing Capscrew Inspection Schedule

Capscrews should be inspected and/or torqued after the initial 250 hours of operation of any new crane or if the crane has been undecked for any reason. Inspect and/or torque capscrews per the Turntable Bearing Capscrew Torque Inspection Schedule, thereafter. Torque capscrews to 2,120–2,335 ft lb (2 875–3 166Nm).

CAUTION

All turntable bearing capscrews use Loctite® 571 Pipe Sealant, or equivalent, with exception given to capscrews coated with Xylan®. The sealant or coating is used to protect the threads of the capscrews from rust and corrosion. Unprotected capscrews will not maintain the proper torque. Always use sealant or coating when installing turntable bearing capscrews.

| Turntable Bearing Capscrew Torque Inspection Schedule | | |
|---|----------|---|
| Schedule | Interval | Requirements |
| A | 500 Hrs | <ul style="list-style-type: none"> Perform an initial torque of the capscrews after the first 250 hours of operation of a new crane, or if the crane has been undecked for any reason, to establish capscrew torque baseline. <p>Note: Use the minimum applicable torque value when checking.</p> |
| | | <ul style="list-style-type: none"> After the next 500 hours of operation, if any of the capscrew torques have degraded, tighten capscrews to the proper torque. <p>Note: Use the minimum applicable torque value when checking.</p> |
| | | <ul style="list-style-type: none"> If the crane is utilized for duty cycle work, Schedule A must be continuously maintained during duty cycle applications. |
| | | <ul style="list-style-type: none"> Inspection Schedule A must be maintained until such a time that no capscrews require tightening after 500 hours of operation. Schedule B can then be followed. |
| | | <ul style="list-style-type: none"> The minimum applicable torque value is acceptable for the turntable bearing capscrew torque inspection. |
| B | Annually | <ul style="list-style-type: none"> If the capscrew torque has degraded at any annual check, Torque Inspection Schedule A must be followed until such time that no loss of capscrew torque is observed. |
| | | <ul style="list-style-type: none"> The minimum applicable torque value is acceptable for the turntable bearing capscrew torque inspection. |

Operator's Manual

Crane Monitoring System

Maintenance of the Rated Capacity Limiter System consists of the following daily inspection prior to the first operation:

1. Check that the system is operating normally as described in Section 1 of this Operator's Manual.
2. Check the electrical cables connecting the various parts of the system.
3. Check insulation on the boom reeling drum cable.
4. Check boom reeling drum cable for proper tension.
5. Check all anti-two block switches for freedom of movement.
6. Check that the anti-two block weights are installed and working properly with the anti-two block switches.
7. Inspect the pressure transducers and the connecting hoses for oil leaks.
8. Test that the function limiters activate properly by simulating a two-block condition. (Do this by manually lifting the ATB weight.)
9. Using a known test weight, check that the displayed weight agrees with the test load. The displayed load includes the hook block and/or hook ball and any lifting equipment such as slings, pins, shackles, etc.
10. If crane capacities are rated for specific areas e.g. side, front, rear, check the system by swinging the boom into the permitted areas and checking that the rated capacity reading agrees with the crane capacities as listed in the Crane Rating Manual.
11. Check for erratic readings on the boom angle, the boom length, and the operating radius displays. Check the boom angle, boom length, and the operating radius for accuracy every 30 days.



WARNING

Any unusual or erratic system operation must be investigated and corrected immediately. If any problem is found with any of the above inspection steps, the problem must be corrected/repared as soon as possible. If necessary to continue crane operations, refer to "System Inoperative Or Malfunctioning" in Section 1 of this Operator's Manual.

Hydraulic Hose Assembly Inspection

The frequency of inspection and replacement of hose assemblies should be determined by the operating environment, the potential risk from a hose failure, and past experience of hose failures in the application and environment.



WARNING

Always wear safety glasses when working with or inspecting pressurized hose assemblies. Do not search for leaks by running your hand or finger along a hydraulic hose. Hot hydraulic oil, under high pressure leaking through a small pinhole in a hose, can puncture gloves, your skin, and penetrate several inches (centimeters) into soft body tissue causing serious personal injury.

A daily visual inspection is recommended for all hose assemblies in service.

1. Check all hose end fittings for cracks, crushing, corrosion, slippage on the hose, leakage, or any other damage.
2. Check all hoses for cracks, exposed reinforcement, chafing, bulging, loose covers, or any other damage.
3. Check the installation of all hose assemblies for any kinked, crushed, flattened, or twisted hoses.

Replace any damaged hose assemblies, hose end mating fittings, and seals as required.

Operator's Manual

Paint Maintenance

Knowledgeable equipment owners realize the value of periodic preventative maintenance and responsible care. A regular surface care program should be followed to protect the equipment's paint finish and maintain a like-new appearance. There is no one correct/ultimate procedure since the uniqueness of every crane's operating environment and owner/operator maintenance habits differ. However, it is important to remove surface contaminants before they have time to bond or etch into the paint finish.

The crane has non-skid materials in certain areas to assist operators and service personnel with safe access/egress to/from the crane. Do not paint or wax non skid materials. Paint or wax will cause the non-skid materials to become slick, reducing their effectiveness for safety while walking on the crane. If any non-skid materials becomes ineffective due to wear, age, or destroyed in any way, it must be replaced.



WARNING

Do not apply paint or wax over non-skid materials. Keep all non-skid materials clean and free of all contaminants. All walking surfaces on the crane should be cleaned to eliminate any contaminants. Paint, wax, or other contaminants will reduce the effectiveness of the materials. Ineffective materials can create unsafe access/egress to/from the crane leading to serious personal injury. Mask off and/or cover non-skid materials prior to painting or waxing areas around any non-skid material(s). Contact a Link-Belt Distributor for information regarding the replacement or repair of any non-skid material(s).

Regular Preventative Maintenance

1. Regular washing is the best way to remove surface contaminants.
2. Always use mild cleaners and soaps, and rinse thoroughly after washing. Do not use harsh detergents, such as household laundry detergents, or cleaners that contain phosphates, as they will "burn" the paint, strip off protective coating, diminish the gloss and accelerate the contamination process.

3. Periodic waxing will enhance the luster and protect the paint surface.

If environmental damage to the paint finish is detected (loss of some of its luster due to lack of or inability to maintain as recommended) the paint finish can be restored to near-new appearance by following a simple polishing and waxing procedure.

Polishing And Waxing Procedure

1. Clean surface thoroughly by hand washing or power washing with a mild detergent. Rinse thoroughly with water before buffing.
2. Apply a polishing compound, such as Meguiar's M8432, or equivalent, to a surface area approximately two feet (.6m) by two feet (.6m) at a time. Ensure the compound is applied liberally to entire area and work on only that area with the buffing wheel.
3. Buff surface with an electric or air buffer at 1,000 rpm using a 3M Superbuff polishing pad, or equivalent, with light to medium pressure until a uniform high gloss is obtained. Hand wipe with a clean cloth.
4. After surface has been buffed, apply a quality automotive wax such a Meguiar's M-26 Hi-Tech Yellow Wax, or equivalent, and hand buff until the cloth moves freely. The original luster of coating should be restored.

Cab Dash Cleaning

Care should be taken when cleaning the cab dash, especially the new polycarbonate dashes. If the incorrect cleaning agent is used, the finish of the material could be destroyed. It is recommended by the dash manufacturer that only the following materials be used for cleaning:

1. Soap and water
2. Denatured alcohol
3. Joy or Palmolive dishwashing liquids
4. Windex with Ammonia D
5. Formula 409
6. Fantastik
7. Mr. Clean

Operator's Manual

Table Of Contents

| | |
|---|-------------|
| Tire Inspection | 3-1 |
| Tire Inflation | 3-1 |
| Tire And Rim Safety Instructions | 3-2 |
| Tire And Rim Removal And Installation | 3-4 |
| Removal | 3-4 |
| Installation | 3-5 |
| Brake Adjustments | 3-5 |
| Travel Swing Lock Adjustment | 3-6 |
| 360 Degree Swing Lock (If Equipped) | 3-6 |
| 360° Swing Lock Inspection And Adjustment | 3-6 |
| Swing Brake Bleeding | 3-7 |
| Bubble Level Adjustment | 3-8 |
| Rated Capacity Limiter | 3-8 |
| Hydraulic System Relief Valve Adjustment | 3-9 |
| Preparing the Crane For Checking Relief Pressures | 3-9 |
| Relief Valve Pressure Checking Instructions | 3-9 |
| Boom Wear Shoe Adjustment | 3-12 |
| Emergency Steer Accumulator Pressure Check (If Equipped) | 3-14 |
| Accumulator Check/Charging | 3-15 |
| First Layer/Third Wrap Calibration | 3-18 |
| First Layer/Third Wrap Control Module Error Codes | 3-19 |
| Boom Angle Indicator Adjustment | 3-20 |

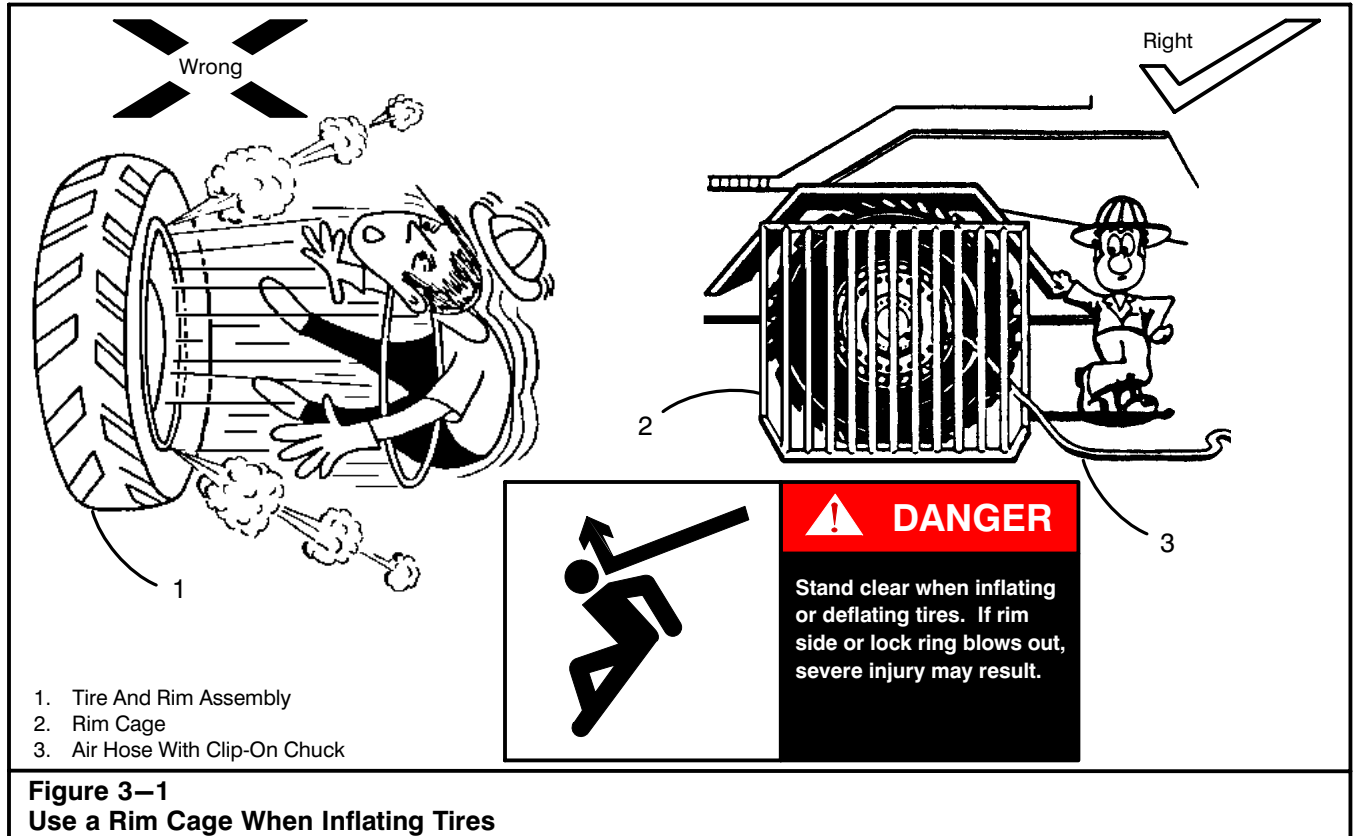
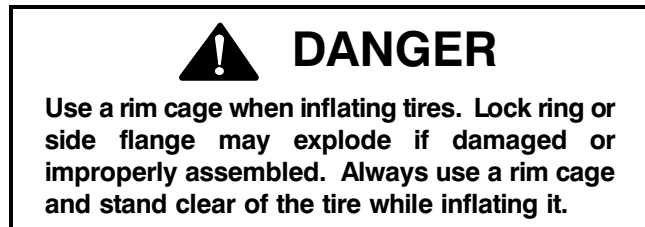

Figure 3-1
Use a Rim Cage When Inflating Tires

Tire Inspection

Inspect the tire treads daily and remove any debris that may be wedged in the tire grooves. Check for nails, screws, glass, or anything that may penetrate the tire and permit air to leak from the tires. Check the side walls and treads for cuts, bulges, and other damage. If internal damage to any tire is suspected, have it demounted and checked. Make all necessary repairs or replace as required.

When replacing tires, all tires should be of the same manufacturer, size, type, load rating, and construction. Refer to the tire manufacturer and follow all recommendations regarding tire inspection and replacement.



Tire Inflation

Check the tire inflation pressures daily when the tires are cold. Use the Tire Inflation Label or the Tire Inflation Chart in the Crane Rating Manual to determine the cor-

rect tire pressure for the type of operation being performed. This label contains recommended tire pressures for different operating conditions. A rim cage should be used when inflating tires to protect the mechanic and any bystanders from the danger of “rim explosion”. Improperly assembled or damaged rim components are subject to explode when tires are inflated. Refer to Figure 3-1.

Two categories of inflation pressures are listed on the , “Maximum Lifts On Rubber” and “Travel Speed”. While the crane is at the job site, the tires should be inflated to the pressure listed under “Maximum Lifts On Rubber” as all job site travel is limited to speeds of 2.5 mph (4km/h) or less. The crane should not be road driven with the tires inflated to “Maximum Lifts On Rubber” pressures.

“Travel Speed” pressures are for highway travel only. Even with the tires inflated to the “Travel Speed” pressures, speed is limited to 20 mph (32km/h) with a 30 minute rest period after each 50 miles (80km) of driving or 2 hours of sustained operation, whichever comes first. One hour minimum stop should be observed after each four hours of operation.

Inspect the wheel rims, clamps, nuts, studs, etc., on a weekly basis. If any damage is apparent, repair or replace before operating the crane.

Operator's Manual

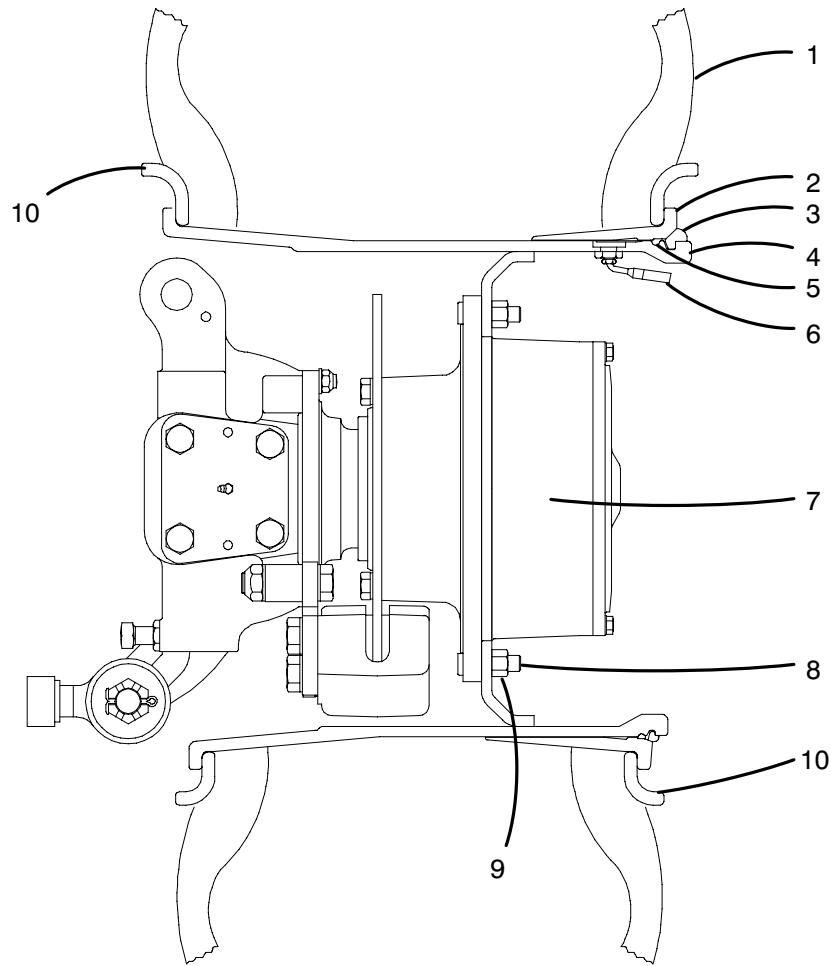

- | | | | |
|--------------|---------------|------------------|------------|
| 1. Tire | 4. Rim | 7. Axle | 9. Lug Nut |
| 2. Bead Seat | 5. O-Ring | 8. Mounting Stud | 10. Flange |
| 3. Lock Ring | 6. Valve Stem | | |

Figure 3-2
Typical Tire And Rim Assembly



DANGER

Servicing any tire and rim assembly can be extremely dangerous. For your protection, read and understand all safety instructions before removing or installing a tire and rim assembly.

Tire And Rim Safety Instructions

1. Always remove the valve cores, and exhaust all air pressure from the tire, prior to removing it. Rim components are under extreme pressure and could fly off.
2. Use a rim cage and stand clear when deflating and inflating tires. A damaged or misassembled rim assembly may burst. The operator should stand well away from the potentially explosive force.
3. After deflating the tire, check the valve stem by running a piece of wire through the stem, to ensure it is not clogged and the tire is completely deflated. Ice may form as the air leaves the tire or foreign material may clog the stem.
4. Do not reinflate a tire that has been run flat or extremely under inflated. Demount the tire and inspect it, the rim components, and wheel end for damage. These components may have been damaged or dislocated during the time the tire was under inflated.
5. Clean and inspect parts prior to assembly. Do not use bent, worn, damaged, or rusted parts.

Operator's Manual

6. When assembling the tire and rim assembly, use only parts of the same type, manufacturer, and correct size. Mismatched parts may appear to fit but when the tire is inflated they may fly apart with explosive force.
7. Always ensure that rim components are properly installed before inflating the tire. Misassembled parts could fly off during inflation.
8. When inflating a tire, use a air hose with a clip-on chuck and in-line pressure gauge. Ensure the air hose is long enough, to permit the person inflating the tire, to stand clear of the rim cage.
9. Inflate the tire to 10 psi (68kPa), and check the rim components for proper fit, before completely inflating. If the assembly is not correct, completely deflate the tire and correct the problem. Do not hammer on an inflated tire and rim assembly. Properly matched and assembled rim components will seat without tapping.
10. Once it is determined that the tire and rim are properly assembled, inflate the tire to the pressure listed on the Tire Inflation Label or the Tire Inflation Chart in the Crane Rating Manual. Do not over inflate the tire.
11. Always check rims and wheel ends for damage during normal tire inspection. Early detection of potential component failure may prevent serious injury.
12. Do not attempt to rework, weld, heat, or braze any damaged rim components. Heating may weaken the part and result in complete failure of the component and possible personal injury.

Operator's Manual

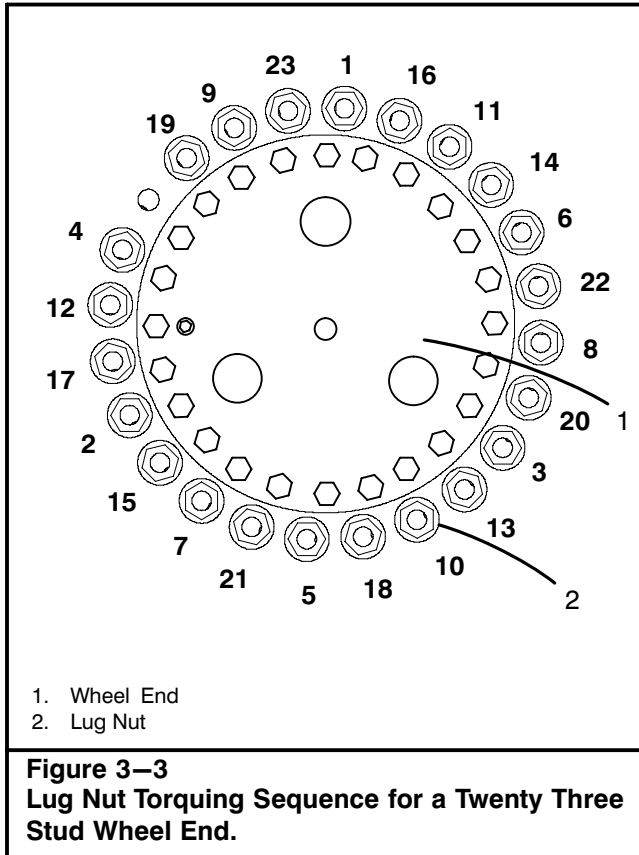

Tire And Rim Removal And Installation

Carefully read and understand the safety instructions in this Section of this Operator's Manual before servicing the tire and rim assemblies.

 **DANGER**

Servicing any tire and rim assembly can be extremely dangerous. For your protection, read and understand all safety instructions before removing or installing a tire and rim assembly.

Removal

1. Properly park the crane and engage the park brake. Level the crane on outriggers with all tires clear of the ground. Shutdown the engine.
2. Position a rim cage in front of the tire and rim assembly before deflating the tire.

 **DANGER**

Exhaust all air pressure from the tire before removing it. Use a rim cage and stand clear when deflating a tire. Rim components are under extreme pressure and may fly off. Failure to exhaust air pressure, or use a rim cage, could result in a fatal accident.

3. Carefully remove the valve core from the valve stem (6). Refer to Figure 3-2. Allow the air pressure to exhaust from the tire (1). Install the valve core back in the valve stem. Remove the rim cage.
4. Remove all but four of the lug nuts (9) from the mounting studs (8). The four remaining lug nuts should be equally spaced around the rim (4).
5. Properly support the tire and rim assembly with an appropriate lifting device.
6. Remove the remaining lug nuts (9) from the mounting studs (8).
7. Carefully remove the tire and rim assembly from the axle (7).

Operator's Manual

Installation

Correct installation and tightening of the tire and rim assembly is one of the most important operations in tire and rim maintenance. When tire or rim problems occur, incorrect installation and tightening procedures are usually found to be the cause of the problem. The following procedures must be carefully followed to ensure safe and dependable service.

1. Check the tire (1) to ensure it is completely deflated. Refer to Figure 3–2. Inspect the flanges (10), bead seat (2), o-ring (5), lock ring (3), and rim (4) for damage and proper assembly.



DANGER

All air pressure must be exhausted from the tire before installing it. An inflated tire may cause improperly assembled rim components to fly off. Failure to deflate the tire could result in a fatal accident.

2. Thoroughly clean the mounting surfaces of the rim (4) and axle (7). Remove any dirt, rust, excess paint, or other foreign materials. Also clean, but do not lubricate, the lug nuts (9) and mounting studs (8).
3. Properly support the tire and rim assembly with an appropriate lifting device. Lift the tire and rim assembly and carefully position it on the axle (7).
4. Install the lug nuts (9) on the mounting studs (8). Tighten the lug nuts evenly to ensure the rim (4) is properly seated on the axle (7).
5. Tighten the lug nuts (9) to 225 ft lb (305Nm). See Figure 3–3 for the proper torquing sequence.
6. Repeat the proper torquing sequence and tighten the lug nuts (9) to their final recommended torque value of 360–470 ft lbs (488–637Nm).



CAUTION

Using improper torque values or torque procedure can cause distortion, slippage, or misalignment of the tire and rim assembly.

7. Properly position a rim cage in front of the tire and rim assembly.



DANGER

Use a rim cage and stand clear when inflating tires. Rim components are under extreme pressure and may fly off. Failure to use a rim cage could result in a fatal accident.

8. Inflate the tire to the pressure specified on the Tire Inflation Label or the Tire Inflation Chart in the Crane Rating Manual.
9. Start the engine, fully retract the outrigger jacks and beams, and drive the crane approximately 1 mile (1.6km). Tighten the lug nuts again to their final recommended torque value of 360–470 ft lbs (488–637Nm) using the proper torquing sequence (Figure 3–3).

Note: Each time a tire and rim assembly is installed the lug nuts should be retightened to the recommended torque value after each 10 hours of operation for the first 50 hours of operation. Check the lug nut torque every 50 hours of operation thereafter.

Brake Adjustments

The crane is equipped with disc brakes which have an automatic adjustment system. Therefore, the brakes should not require any adjustment. However, the brake linings should be periodically inspected for wear and replaced as required.



WARNING

Brake linings wear and leave a “dust” in the area of the brakes. This “dust” can be hazardous. Wear a mask while working with brake linings to prevent breathing the “dust”.

Operator's Manual

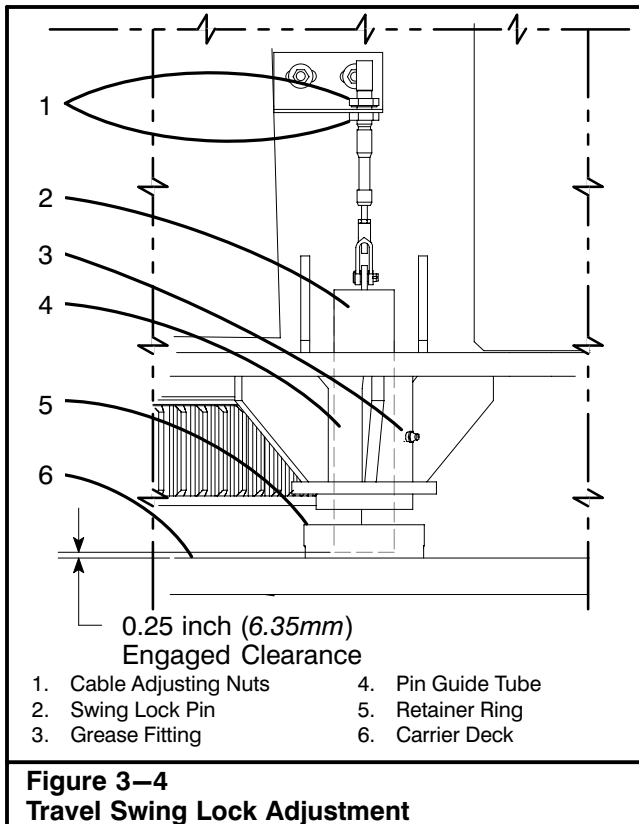

Travel Swing Lock Adjustment

The travel swing lock is a two position, positive lock of the upper over the carrier to prevent swinging of the upper. For the travel swing lock to operate properly, it must be adjusted correctly.

1. Park the crane on a firm level surface. Shift transmission to neutral and engage the park brake. Level the crane on outriggers.
2. Check that the travel swing lock is engaged and shutdown engine. Refer to Figure 3-4.
3. Check the engagement of the swing lock pin in the retainer ring on the carrier deck. The pin should extend in the retainer plate to within .25 inch (6.35mm) of the carrier deck.
4. Adjust the stroke of the swing lock as required by using the cable adjusting nuts.
5. Test the swing lock in each working position before operating the crane.

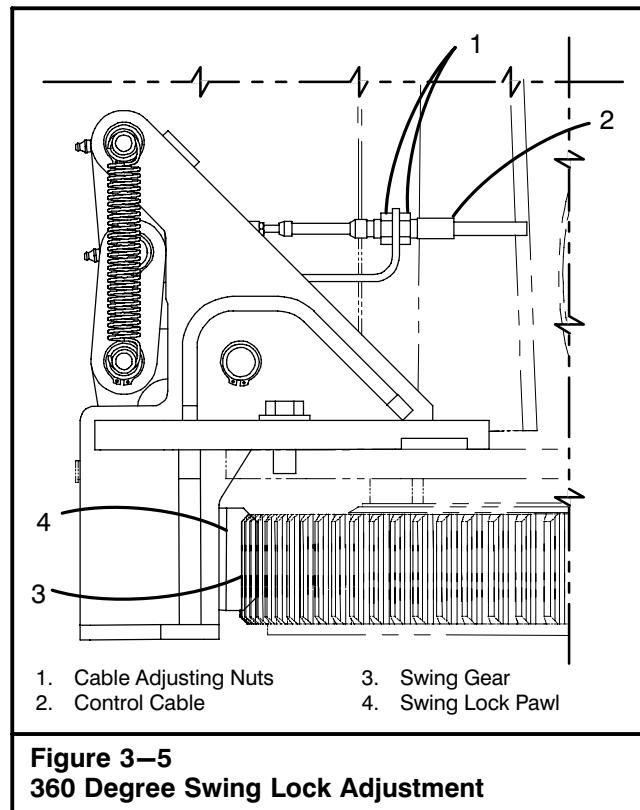

360 Degree Swing Lock (If Equipped)

The 360° swing lock, if equipped, functions to prevent rotation of the upper over the carrier by engaging a pawl in the external swing gear teeth. For the swing lock to operate properly it must be adjusted correctly.

360° Swing Lock Inspection And Adjustment

1. Park the crane on a firm, level surface, shift the transmission to neutral, and apply the park brake. Level the crane on outriggers.
2. Engage the travel and 360° swing locks. Shutdown the engine.
3. Visually inspect the 360° swing lock pawl. The pawl should be fully engaged with the linkage just over center. Refer to Figure 3-5.
4. If the pawl is not fully engaged and the linkage is not just over center, use the cable adjusting nuts to correctly position it.
5. Tighten the adjusting nuts and test the 360° swing lock before operating the crane.

Swing Brake Bleeding

Bleed the swing brake whenever a hydraulic line is removed from the swing unit to remove any air that may have been trapped in the circuit. Use the following procedure to bleed the swing brake.

1. Park the crane on a firm, level surface. Shift the transmission to neutral and engage the park brake.
2. Engage travel swing lock and shutdown the engine.
3. Position a suitable container under the bleeder plugs.
4. Loosen the park brake bleeder plug. Refer to Figure 3–6. Turn the key switch to the “ON” position but do not start the engine.
5. Operate the swing park brake control switch. Allow the fluid to discharge into the container until no air is present. Tighten the park brake bleeder plug.
6. Turn the key switch to the “OFF” position.
7. Loosen the service brake bleeder plug. Push the swing brake pedal and allow the fluid to discharge into the container until no air is present. Tighten the service brake bleeder plug.
8. Check the hydraulic oil level. Refer to “Hydraulic Reservoir Oil Level Check” in Section 2 of this Operator's Manual.
9. Test all swing brake functions before operating the crane.
10. Properly dispose of used oil.

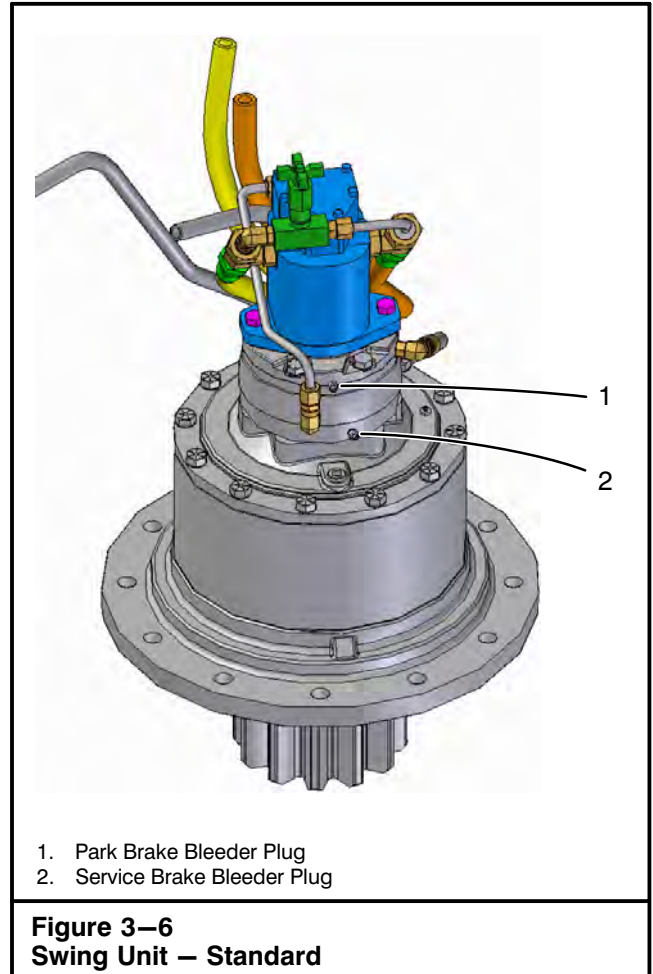

Operator's Manual

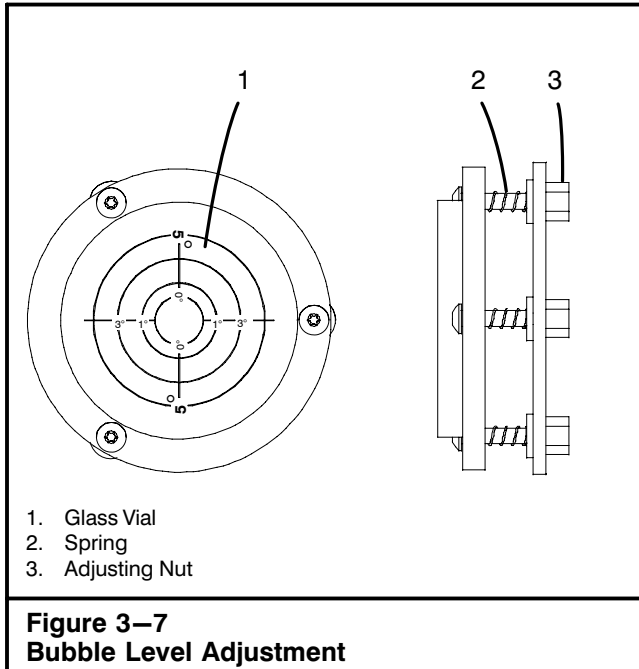

Bubble Level Adjustment

A bubble level, for leveling the crane on outriggers, is mounted in the upper cab on the right side wall. It should be checked periodically to ensure proper adjustment.

1. Park the crane on a firm level surface, shift the transmission to neutral, and engage the park brake.

2. Level the crane on fully extended outriggers. Position the upper over the front of the carrier and engage the travel swing lock. Fully retract the boom. Boom down to 0° angle.
3. Verify the crane is level by placing a carpenter's level across the front of upper frame. Check levelness with the upper over the rear and over the side of the crane. Adjust the outriggers as necessary.
4. Rotate the adjustment nuts as required until the bubble is centered within the vial. Refer to Figure 3-7.

Note: Do not flatten out the springs under the bubble level. Loosen rather than overtighten the adjustment nuts to gain the necessary adjustment.

Rated Capacity Limiter

A properly calibrated Rated Capacity Limiter is critical for safe crane operation. The boom angle and length are crucial factors in determining crane capacities. The Rated Capacity Limiter must be checked for accuracy on a daily basis and calibrated as needed. Refer to "Crane Monitoring System" in Section 2 of this Operator's Manual for the daily check list for the system.

The Rated Capacity Limiter should be calibrated by a qualified technician only. Contact a Link-Belt Distributor or to arrange for a qualified technician to perform the calibration procedures.

Hydraulic System Relief Valve Adjustment

The following instructions pertain to checking and setting all relief valve pressures in the hydraulic system. All cranes are tested and properly adjusted before leaving the factory and should not need checking when first put into operation. Each 250 hours of operation, the relief valve pressure settings should be checked. A drop in relief valve pressure setting may be noticed the first time checked. This is normal and is probably due to lessening of spring tension or stress relief in relief valve parts.

If a new or rebuilt pump is installed, all relief valve pressures must be backed off and reset, as outlined in this Section of this Operator's Manual before putting the crane in operation. The purpose of this is to avoid the possibility of damaging the new pump from over pressurization, if relief valves are set incorrectly. Do not operate the crane over relief pressures for extended periods of time to avoid overheating of hydraulic oil.



DANGER

When it is required to operate the crane during maintenance and/or adjustments, use extreme caution as service personnel may have to work near and/or under moving machinery. Serious personal injury and/or death may result. Always remain in visual and/or verbal contact to ensure the safety of service personnel. Use a signal person if necessary.

CAUTION

Relief valves are provided to protect the hydraulic system. Do not increase relief valve pressures above specifications or hydraulic system damage may occur.

Preparing the Crane For Checking Relief Pressures

1. Park the crane on firm level surface, shift the transmission to neutral, and apply the park brake.
2. Level the crane on outriggers and operate the hydraulic functions as required to bring the hydraulic oil temperature to its normal operating range. Refer to Section 2 of this Operator's Manual for oil operating temperature ranges.
3. Engage the travel swing lock with the upper directly over the front of the carrier.

4. Fully retract and lower the boom. Shutdown the engine.

Note: Checking relief valve pressures is simplified by using two persons, one in the operator's cab to operate the controls and one to check and adjust the relief valves.

Relief Valve Pressure Checking Instructions

Refer To Figure 3–8 and Figure 3–9 for relief valve and quick disconnect fitting locations.

1. Use a gauge of known accuracy. Have the gauge calibrated if necessary. Use a snubber or gate valve to reduce shock loading in the gauge.
2. Release the hydraulic system precharge pressure by loosening the filler/breather cap on the hydraulic reservoir 1/4 turn until pressure is fully relieved.
3. Turn the key to the "ON" position but do not start the engine and work the control or switch, for the circuit being checked, back and forth to relieve any trapped hydraulic pressure.



WARNING

All trapped hydraulic pressure must be exhausted from the system before installing a gauge in any quick disconnect. A sudden release of hot oil could cause burns or other serious injury.

4. Install the pressure gauge on the quick disconnect fitting.
5. Refer to the Figure 3–8 to determine the correct pressure setting for the circuit being checked. Also, review the procedure for checking that particular circuit outlined in the chart.
6. Start the engine.
7. If applicable, fully engage the control for the circuit being checked and hold it in that position.
8. With the engine running at the speed specified in Figure 3–8, check the gauge for the correct reading, adjust as required.

Note: Obtain each final pressure by bringing the pressure up to the proper setting, not by backing down to it.

9. Allow the engine to return to idle before shutting it down.
10. Release the hydraulic system precharge pressure and work the control back and forth to relieve any hydraulic pressure before removing pressure gauge from the quick disconnect fitting.

Operator's Manual

Hydraulic Pressure Settings

| Relief Valve | Hydraulic Circuit | Quick Disconnect & Adjustment Location | Relief Valve Setting* | Procedure For Setting The Relief Valve |
|--------------|--------------------------------|--|---|--|
| 1 | Pilot Control | Figure 3–9 A & B | 500 psi +0 –50 psi (3 448kPa) (+0 –344kPa) | Fully Steer Right or Left & Hold, Check Pressure. Engine At Idle. |
| | Latching Cylinder Supply | Figure 3–9 C & F | 475±25 psi (3 275±172kPa) | Check Pressure with Engine At Idle. |
| 2 | Outrigger | Figure 3–9 D & E | 3,000 psi (20 685kPa) | Fully Retract An Outrigger Beam & Hold, Check Pressure. Engine At Full Throttle. |
| 3 | Steering | Figure 3–9 F & G | 2,500 psi (17 237kPa) | Crane on Tires, Boom Fully Retracted, Travel Swing Lock Engaged with Boom Over Front & 2-Wheel Steer Engaged. Fully Steer Left Or Right & Hold, Check Pressure. Engine At Full Throttle. |
| | Swing | Figure 3–9 F & H | 2,000 psi (13 790kPa) | Swing Left & Hold, Check Pressure. Swing Right & Hold, Check Pressure. Engine At Idle. |
| 4 | Boom Hoist/ Boom Telescope | Figure 3–9 I & J | 4,300 psi (29 648kPa) | Crane on Fully Extended Outriggers, Travel Swing Lock Engaged, Upper Over Front. Fully Boom Down & Hold, Check Pressure. Engine At Full Throttle. |
| | Unloader Stabilization | Figure 3–9 K & L | 75 psi +25 –0 psi (517kPa) (+172 –0kPa) | Check Pressure with Engine At Idle. |
| 5 | Front & Rear Winch | Figure 3–9 M & N | 3,500 psi (24 132kPa) | Remove & Plug Line to the Winch Brake. Engage Winch Down & Hold, Check Pressure. Engine At Full Throttle. |
| 6 | Counterweight Removal | Figure 3–9 O & P | 1,000 psi (6 895kPa) | Crane on Fully Extended Outriggers. Boom Fully Retracted, Travel Swing Lock Engaged with Boom Over Front. Unpin the Counterweight from Upper. Press the DOWN Button & Hold. Check Pressure with Engine At Full Throttle. |
| 7 | Air Conditioning (If Equipped) | Figure 3–9 Q & F | 2,700 psi (18 616kPa) | Set Steering Relief Valve to 3,700 psi (25 511kPa). Fully Steer Left Or Right & Hold, Check Pressure. Engine At Full Throttle. Reset Steering Relief to Correct Setting. |
| 8 | Fine Metering | Figure 3–9 R & S | 95 psi (655kPa) | Engine At Idle. Swing Right & Hold, Check Pressure. Adjust Fine Metering Valve to Correct Setting. |

***Adjust All Pressures to Within ±50 psi (344kPa) Except Where Noted.**

**Figure 3–8
Relief Valves Pressures & Adjusting Procedures**

Operator's Manual

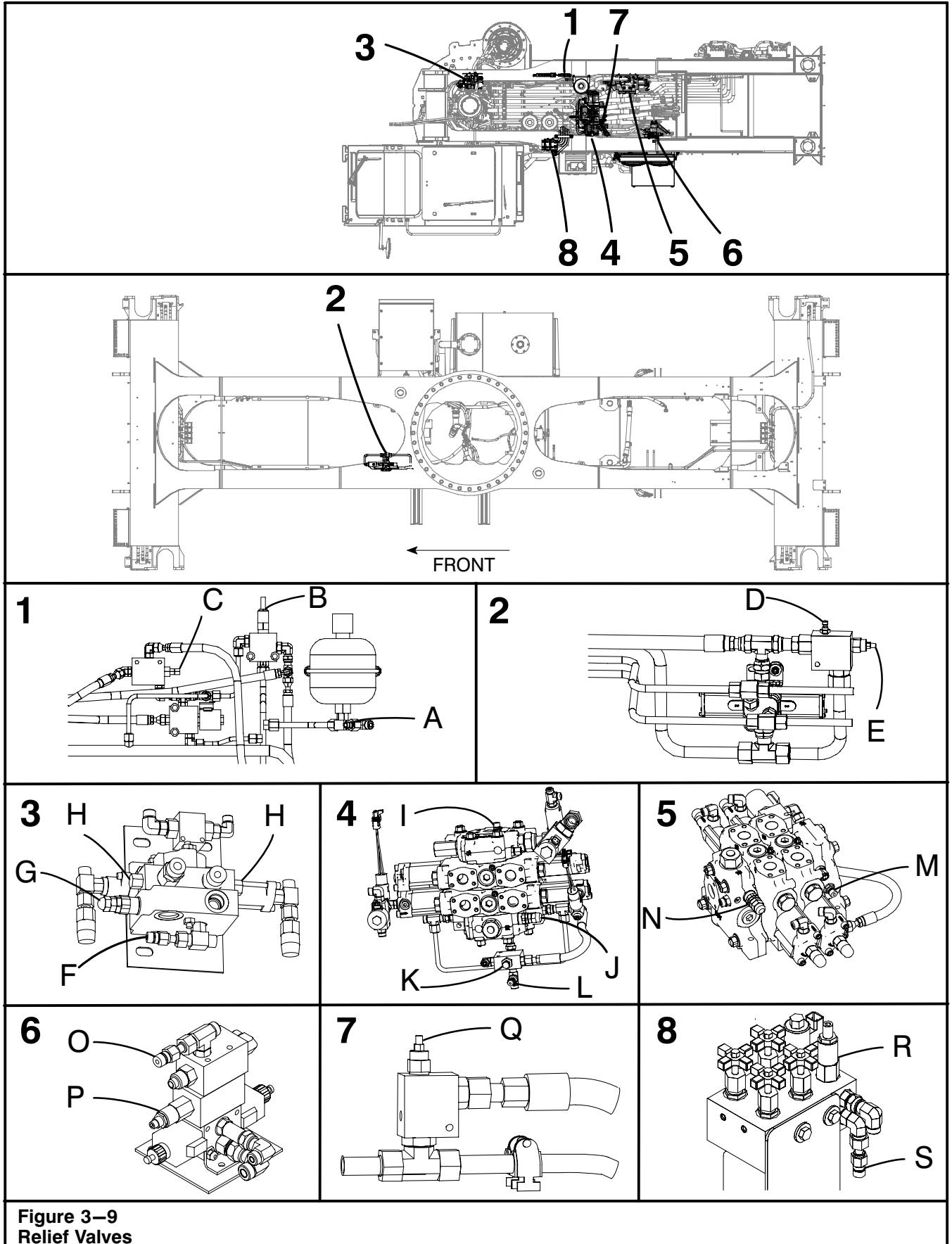

Operator's Manual

Boom Wear Shoe Adjustment

Boom wear shoes are provided as a means of keeping the boom working smoothly. They must be adjusted periodically to prevent excessive deflection of the boom sections. Refer to Figure 3–10.

1. Level the crane on fully extended outriggers with all tires clear of the ground. Swing the upper over the front of the carrier and engage the travel swing lock. Lower the boom and extend each boom section as required to gain access to each wear shoe.



WARNING

To avoid personal injury, do not climb, stand, or walk on the boom. Use a ladder or similar device to reach necessary areas.

To prevent movement of individual boom sections, shutdown the engine and ensure that the operator has properly vacated the operators cab before putting fingers, hands, arms, or tools inside the boom. Unexpected movement of the boom sections could sever fingers, hands, arms, etc.

2. Adjust the following wear shoes to ensure the boom is straight and each boom section is centered within the next.
 - a. Front Top Wear Shoes
 1. There are a pair of front top wear shoes on the base, T1, T2, and T3 boom sections. They are adjustable in both horizontal and vertical directions. The horizontal adjustment is used to center one boom section inside the other. Measure the clearance between sections on each side and space them equally. The wear pads should contact the inside section on both sides. No clearance between wear shoe and boom section is required.
 2. Vertical adjustment is used to hold the wear shoe down against the top of the inside boom section. Again this can be adjusted so that there is no clearance between wear pads and boom section.
 3. Replace when shoe is worn to 0.375 in (0.95cm) minimum thickness.

- b. Rear Top Wear Shoes
 1. There are a pair of rear top wear shoes on each side of the T4, T3, T2, and T1 boom sections. Access the adjustment screw through the hole in the top of the adjacent section.
 2. Horizontal adjustment is accomplished with shims. This adjustment is used to align one section inside the other. The straightness of the boom is dependent on this adjustment. Small holes in the sides of the boom sections allow measurements between the section. Set the gap between sections equal on both sides to ensure boom straightness. It is helpful to lift the boom slightly to relieve some weight from the top rear shoes when adjusting.

Note: These wear shoes can be rotated to provide more service life before replacement as they will tend to wear on the top more than the on the side.

- c. Rear Side Wear Shoes
 1. There are a pair of rear side wear shoes on the T1, T2, T3, and T4 boom sections. They are adjustable in the horizontal direction. The horizontal adjustment is used to reduce boom side deflection.
 2. Horizontal adjustment is accomplished with shims. Access the adjustment shims through the holes in the sides of the external boom section when the boom is extended.
 3. Replace these wear shoes when they reach a thickness less than 1 in (2.54cm).
3. Check the thickness of the front bottom wear shoes. The wear shoes and spacers are to be replaced when the bottom most wear shoes reach a minimum thickness of 1/2 in (1.3cm). To replace these shoes, remove the top front wear shoes, lift up on the inside section, and remove and replace the shoes. Reinstall and adjust the top front wear shoes.
4. After adjusting the boom wear shoes, boom up to a 60° angle and fully extend the boom. Ensure the boom is straight and the sections are centered within each other.

Note: External effects such as sun and wind on one side of the boom or having the crane out of level can make the boom appear to not be aligned. Negate these effects as much as possible when checking boom straightness. Refer to “Boom Distortion Due To Thermal Effects Of The Sun” in Section 1 of this Operator's Manual.

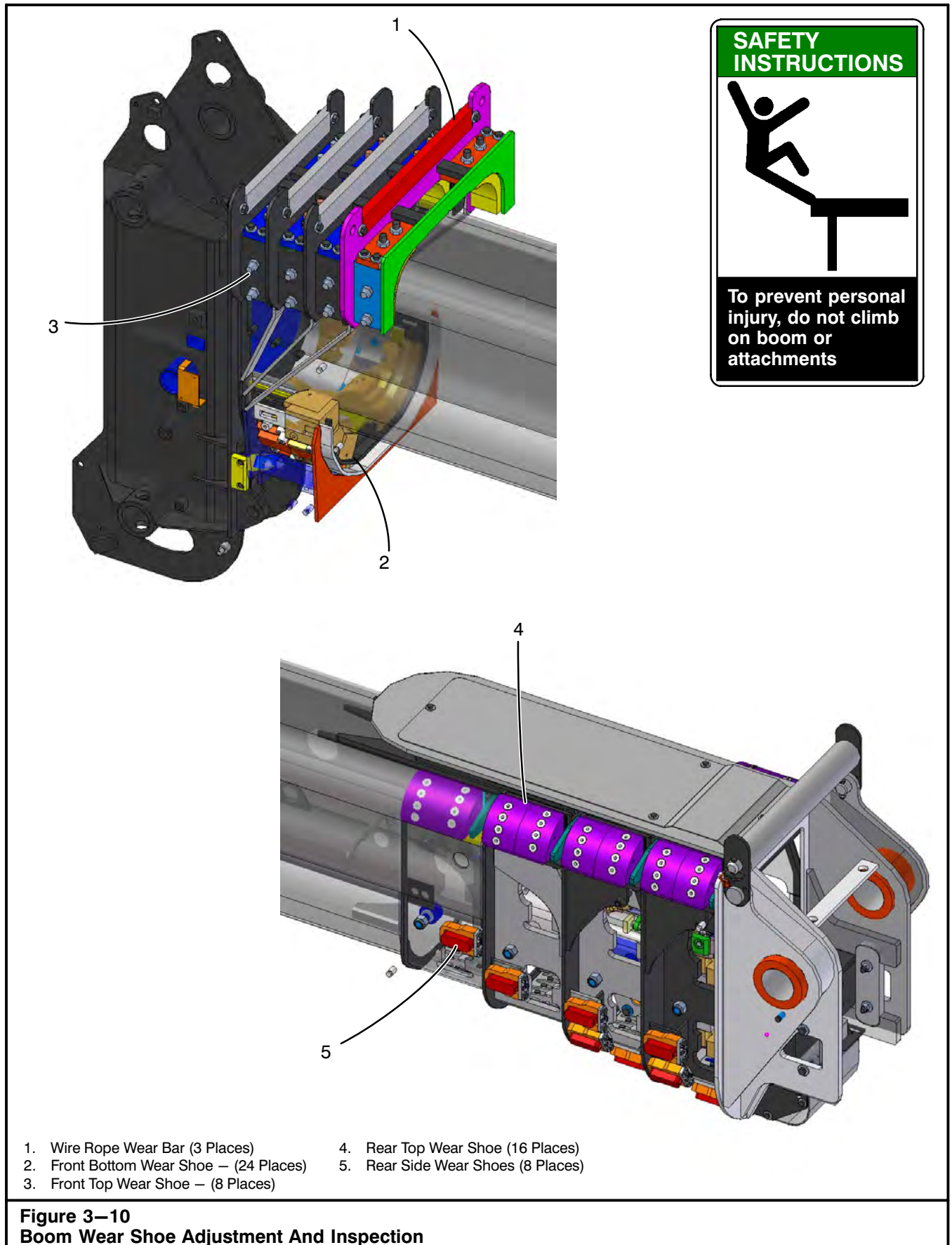

Operator's Manual

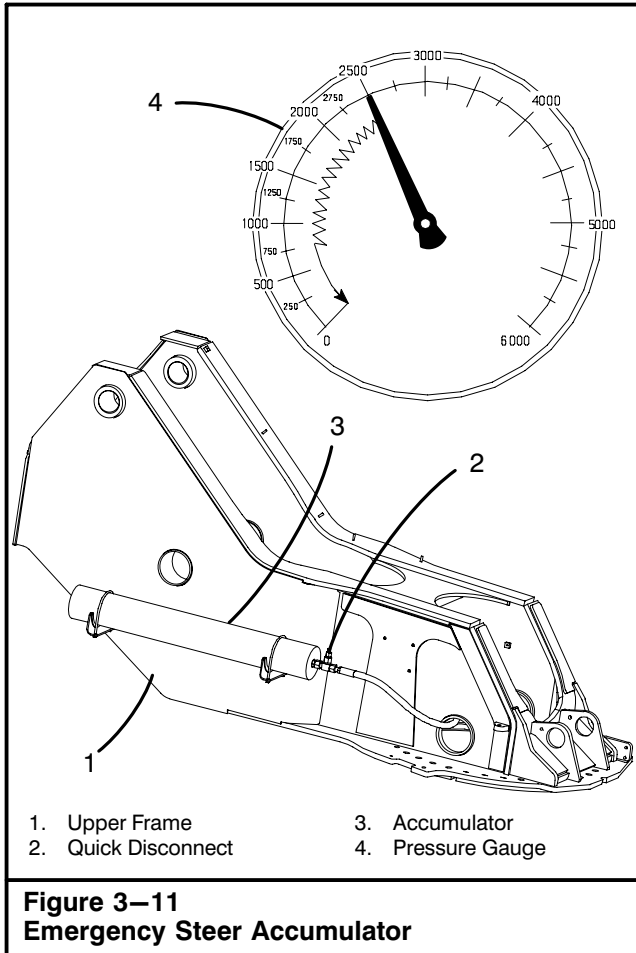

Emergency Steer Accumulator Pressure Check (If Equipped)

In the event of hydraulic pressure failure, the emergency steer accumulator is used to supply the hydraulic steering circuit with enough pressure to allow the operator to negotiate approximately eight 90° turns of the steering wheel. The accumulator pressure should be checked at 250 hour intervals to ensure the accumulator is properly pressurized. To check the accumulator pressure use the following procedures along with Figure 3-11.

1. Park crane on firm level surface, shift the transmission to neutral, and apply the park brake.

2. Level the crane on outriggers, position the upper directly over the front of the carrier, and engage the travel swing lock.
3. Properly check and adjust the steering relief valve as outlined in "Hydraulic System Relief Valve Adjustment" in this Section of this Operator's Manual.
4. Shutdown the engine and bleed all pressure from the accumulator by rotating the steering wheel back and forth until no pressure is available to move the wheels.



WARNING

All trapped hydraulic pressure must be exhausted from the system before installing a gauge in any quick disconnect. A sudden release of hot oil could cause burns or other serious injury.

5. Connect the pressure gauge to the quick disconnect on the hydraulic input to the accumulator.

Note: Pressure gauge must be accurate up to 3,000 psi (20 685kPa).

6. Start the engine and align the tires straight ahead. Engage 2-wheel steer.
7. To charge the accumulator, engage the outrigger jack cylinder control switches to the "EXTEND" position and hold until pressure gauge reads 2,500 psi (17 237kPa). The engine should be running at half throttle.
8. Shutdown engine and turn ignition switch to the "ON" position but do not start engine.
9. Turn the steering wheel to full left, then full right, then full left while counting the number of cycles as wheel crosses the straight ahead position.

Note: One full cycle equals center, to full left, to full right, to center (four 90° turns).

10. Observe the pressure gauge while accumulator pressure is being steered down. Note the pressure reading at which the accumulator pressure drops off rapidly. This is the accumulator precharge pressure, which should be 750 psi (5171kPa).

Note: One and a half cycles (six 90° turns), minimum should be obtained from a complete accumulator precharge.

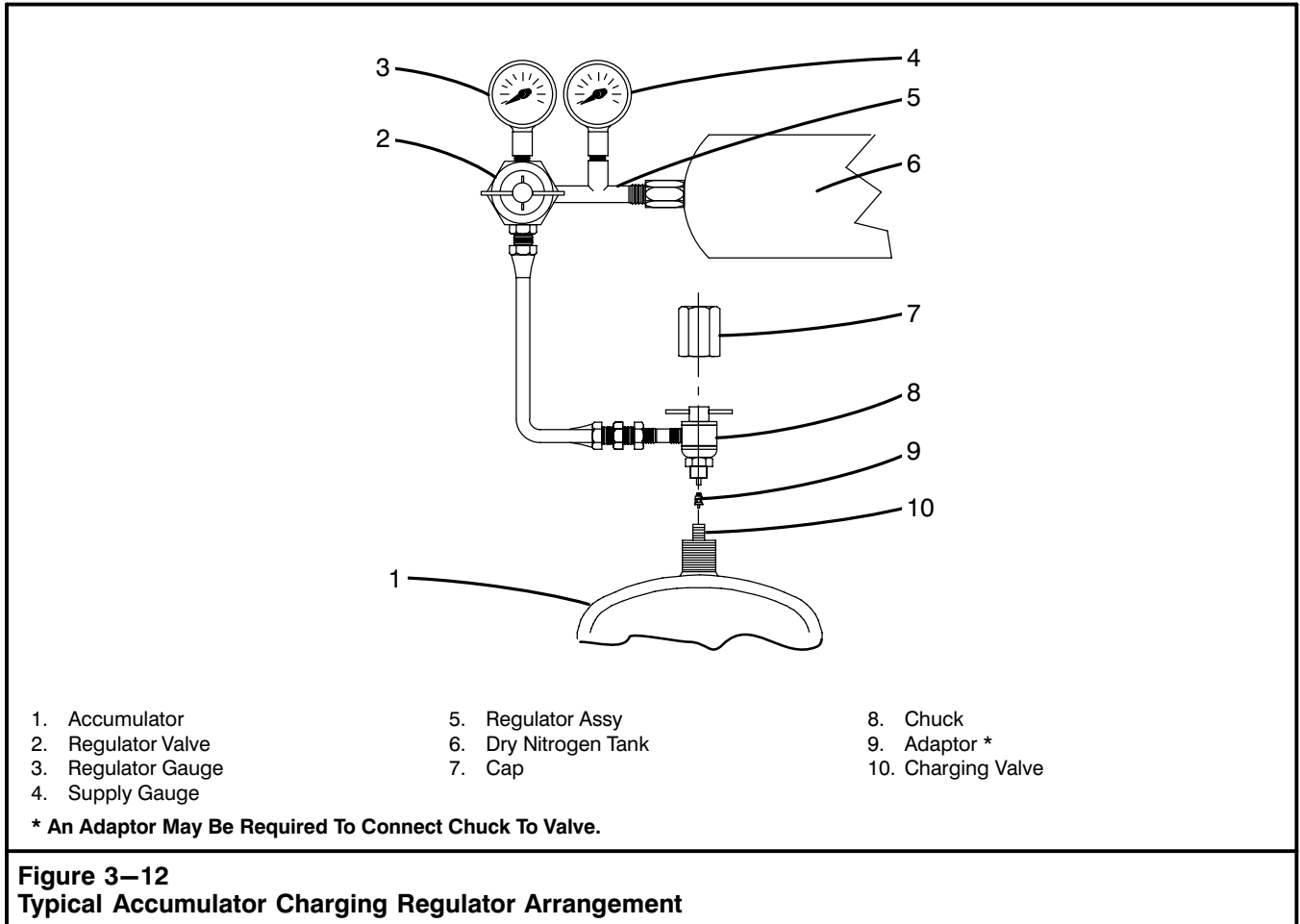

Accumulator Check/Charging

The crane may be equipped with up to five accumulators. These accumulators are pressurized with dry nitrogen. The accumulator pressure should be checked at 250 hour intervals to ensure the accumulators are properly pressurized.

There are three bladder type accumulators on the upper. Two are in the carrier service brake hydraulic circuit and one is in the pilot control circuit. If the crane is equipped with the hydro-gas suspension, a piston type accumulator is on the carrier within that hydraulic circuit. If the crane is equipped with emergency steering, an accumulator is on the right side of the upper frame. Refer to "Emergency Steer Accumulator Pressure Check (If Equipped) Emergency Steer Accumulator Pressure Check (If Equipped)" in this Section if the Operator's Manual.

The accumulators may be checked and/or charged with the unit installed or removed from the crane. If unit must be removed from the crane, refer to the crane Shop Manual for the correct procedure. Use the following procedure to check and/or charge the accumulators.

1. Lower, detach, and secure load, as required.
2. Stabilize the crane for service as follows:
 - a. Park the crane out of the way on a firm and level surface.
 - b. Engage the park brake and/or properly block the tires.
 - c. Engage the swing park brake and/or travel swing lock, as required.
 - d. Level the crane on fully extended outriggers.
 - e. Fully retract and lower the boom, as required.

Operator's Manual

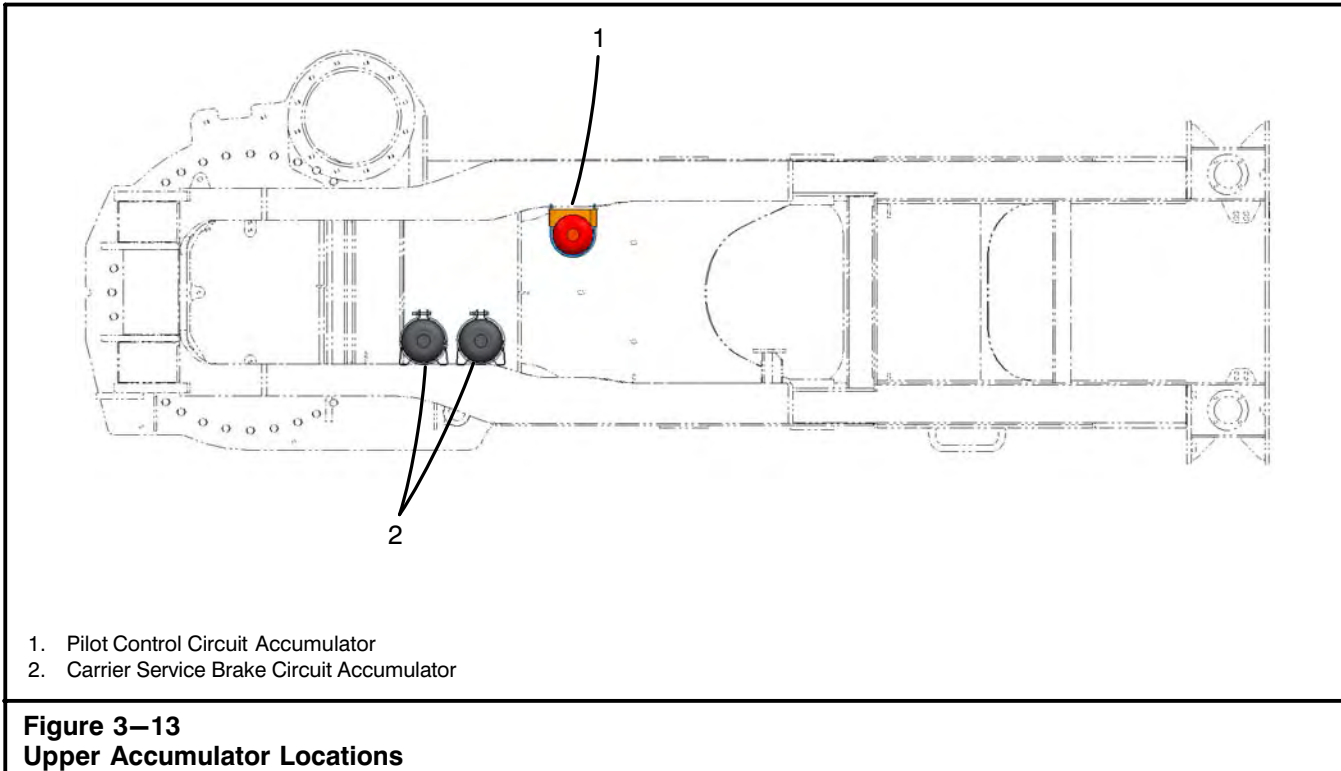

3. Shutdown the engine and disengage the main hydraulic pump.



WARNING

Solvents and cleaning solutions can be hazardous. Serious personal injury may result from misuse of these products. Read and follow all the manufacturer's recommendations concerning solvents and cleaning solutions.

4. Thoroughly clean area to be disassembled with an approved cleaning solvent to prevent contamination from entering the hydraulic oil circuits. Allow the area to air dry.



WARNING

Hydraulic oil is under pressure and may be hot. A sudden release of hot oil could cause burns or other serious injury. Shutdown the engine and exhaust all trapped hydraulic pressure from the system before removing any line or component.

5. To relieve hydraulic system pressure:

- a. Turn the ignition switch to "ON", but **DO NOT START THE ENGINE**. Move the function lock-out switch to the "OPERATE" position.
- b. Work the crane control levers and outrigger switches back and forth several times.
- c. Rotate the steering wheel back and forth repeatedly until steering becomes hard. (On cranes equipped with emergency steering system, it will take several rotations of steering wheel before steering becomes hard.)
- d. Loosen the filler/breather cap on the hydraulic reservoir 1/4 turn until all pressure is fully relieved.
- e. Turn ignition switch to the "OFF" position.
6. Check that all control levers are in the neutral position and move the function lockout switch to the "DISABLE" position.
7. Remove cap (7) from the accumulator. Refer to Figure 3–12.
8. Close the regulator valve (2) and the valve on the dry nitrogen tank (6).
9. Connect the regulator assembly (5) to the dry nitrogen tank (6).
10. Open the valve on the dry nitrogen tank (6). The regulator gauge (3) should read 0 psi (0kPa). If required, close the regulator valve (2) to achieve the zero pressure at the regulator gauge (3).

Operator's Manual

- Note the reading on the supply gauge (4). The dry nitrogen tank must contain sufficient volume and pressure to charge the accumulator.
- Connect chuck (8) to the charging valve (10) and turn the t-handle clockwise to open the charging valve (10).
- When charging a new accumulator (1), open the regulator valve (2) slowly until the regulator gauge (3) reads 5 psi (34kPa).
- Slowly open the regulator valve (2) until the regulator gauge (3) reaches the correct pressure. Refer to the following table for the correct pressure.

| Accumulator | Pressure | |
|-----------------------------------|----------|-------|
| | psi | kPa |
| Carrier Service Brake Circuit (2) | 1,300 | 8 963 |
| Pilot Control Circuit | 100 | 689 |
| Hydro-Gas Suspension Circuit | 900 | 6 205 |

- Close the valve on the dry nitrogen tank (6) and turn the t-handle of the chuck (8) counterclockwise to close the charging valve (10).

- Remove the chuck (8) from the charging valve (10) and inspect the charging valve (10) for leaks. There will be a slight discharge of nitrogen when the chuck (8) is removed.

Note: Allow accumulator to rest 10–15 minutes after charging. This will allow gas temperature to adjust and equalize. Recheck gas pressure and adjust as necessary.

- Check the charging valve (10) for leaks with soapy water. If leaks are present, repair as required.
- If no leaks are present, install the cap (7) on the accumulator (1).
- Check hydraulic reservoir oil level. Add oil as required. Refer to Section 2 of this Operator's Manual for correct type and procedure.
- Start the engine and let idle for five minutes. Inspect the connections on the hydraulic lines for leaks. Repair if needed.
- Test all hydraulic functions of the crane for proper operation before placing the crane into service.

Operator's Manual

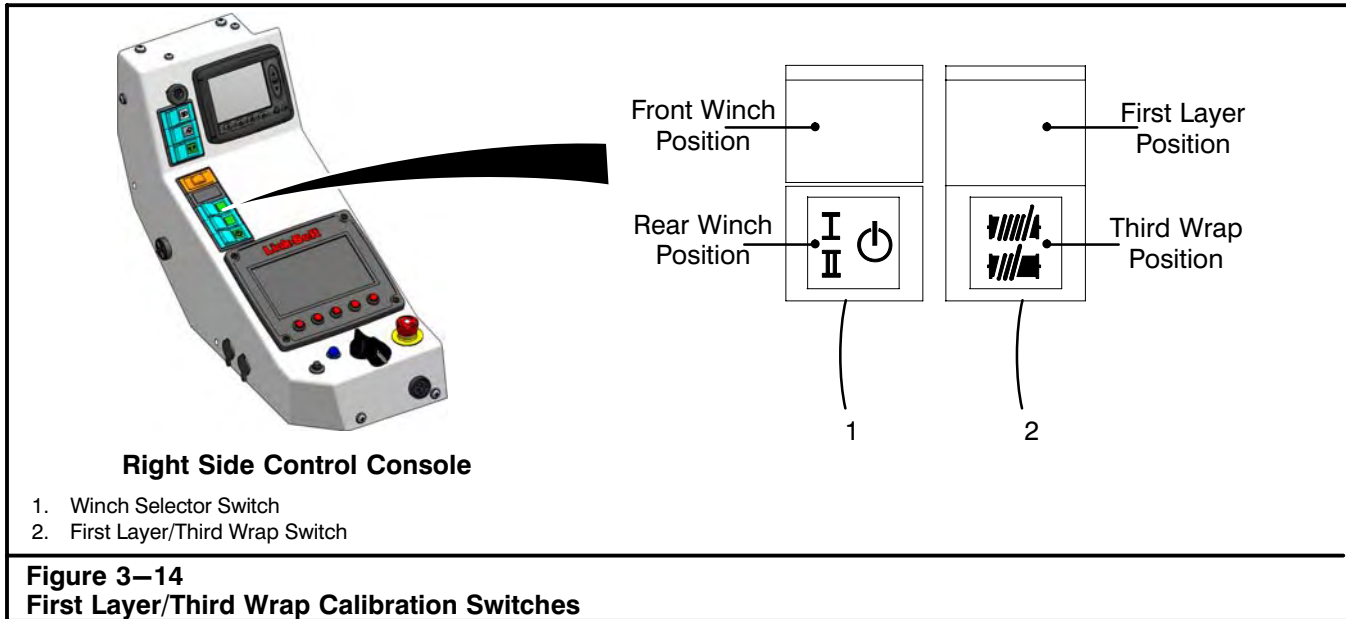

First Layer/Third Wrap Calibration

The crane may be equipped with a first layer/third wrap warning system. This system allows the operator to monitor the wire rope windings on the drum(s). In order for this system to function correctly, it must be properly calibrated using the switches on the right side control console. Refer to Figure 3-14. Calibrate the system anytime wire rope is installed on the winch drum(s) or the live end of the wire rope is wound past the winch.



WARNING

The first layer/third wrap system will not function properly if the live end of the hoist wire rope is wound past the winch. Wire rope failure may occur. Recalibrate the first layer/third wrap system so that three (3) full wraps of wire rope is maintained on the winch drum(s) at all times during operation.

1. Park the crane on a firm level surface, position transmission shifter to neutral, and engage the park brake.
2. Set the RCL system to Rigging mode.



WARNING

The RCL System is not operational when in the RIGGING/TRAVEL Mode. Return the RCL System to normal operation before operating the crane.

3. Spool wire rope off the front drum until only four full wraps are left on the drum. Or if installing wire rope on the drum, properly install the drum wedge to anchor the wire rope to the drum. Refer to Section 5 of this Operator's Manual. Properly wind four full wraps on the drum.
4. Visually verify that three full wraps are on the drum before proceeding.
5. Press the Winch Selector switch to the Front Winch position and hold. Refer to Figure 3-14.
6. Press the First Layer/Third Wrap switch to the Third Wrap position and hold for one second and then release both switches.
7. Spool wire rope onto the drum until the first layer is wound fully onto the drum. Visually verify that one full layer is spooled correctly on the drum before proceeding.
8. Press the Winch Selector switch to the Front Winch position and hold.
9. Press the First Layer/Third Wrap switch to the First Layer position and hold for one second and then release both switches.
10. Properly spool the remaining wire rope on the drum. Refer to Section 5 of this Operator's Manual.
11. Repeat procedure for rear winch.
12. Return RCL system to normal operating mode.
13. Check the First Layer/Third Wrap Control Module behind the operator's seat to confirm the system is functioning normally. Refer to First Layer/Third Wrap Control Module Error Codes in this Section of this Operator's Manual.

First Layer/Third Wrap Control Module Error Codes

The First Layer/Third Wrap Control Module controls and monitors the first layer/third wrap system. The module is behind the upper operator's seat. The module contains two LED indicators to determine the status of the system. The green LED on top of the module indicates power on. The yellow flashing LED indicates normal status. If there is an error detected, the module will present a message on the display. The module also indicates error status through the red/yellow flashing LED. Refer to the following charts for error message information.

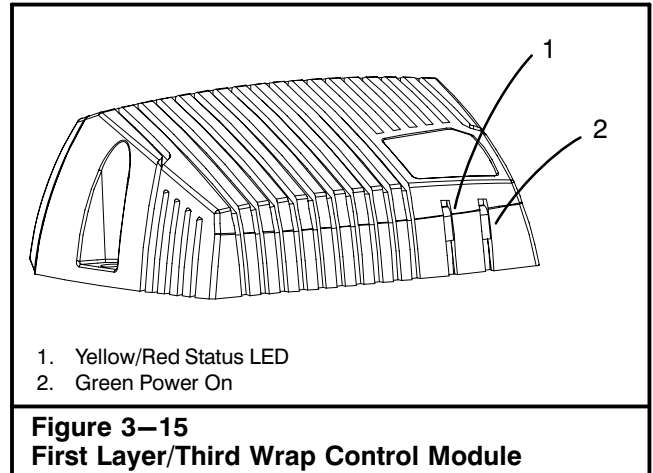

| First Layer/Third Wrap Control Module Modes | |
|---|----------------|
| Status | Flash (Yellow) |
| Normal Operation | |
| Application Not Loaded | |
| No Application Available | |
| Bad Application | |
| Busy | |

| First Layer/Third Wrap Control Module Error Codes | | | |
|---|--------------------------|---------------------|--------------------------|
| Error Code | Error | Primary Flash (Red) | Secondary Flash (Yellow) |
| 1:1 | Output | | |
| 1:2 | Input | | |
| 1:3 | Vref (Reference Voltage) | | |
| 2:1 | Power Supply | | |
| 2:2 | Temperature | | |
| 2:3 | Clock | | |
| 3:1 | CAN Error | | |
| 3:2 | Address Error | | |
| 4:1 | Internal Error | | |
| SCS | Safe Crash State | | |

Operator's Manual

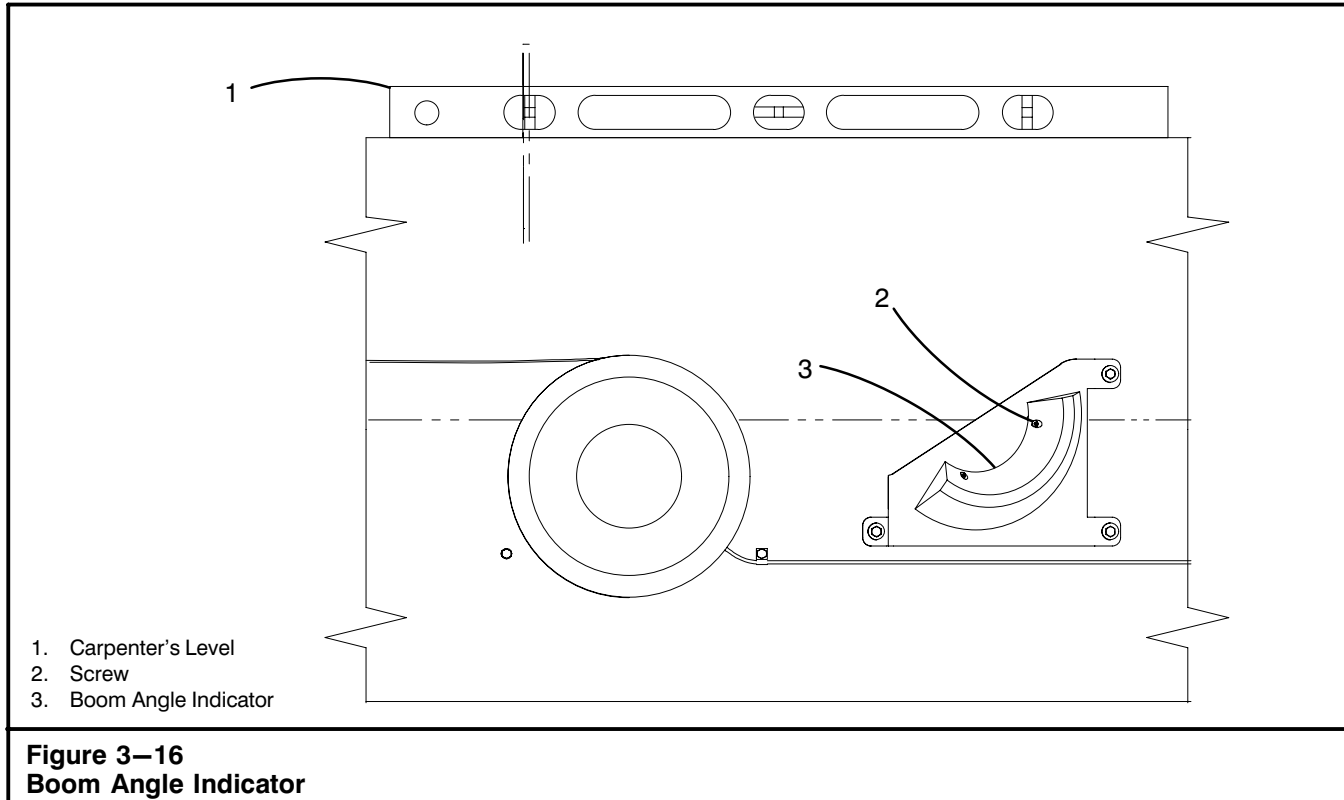

Boom Angle Indicator Adjustment

A bubble type boom angle indicator is mounted to the right of the operator's cab on the base section of the boom. Refer to Figure 3–16. It must be adjusted properly and the crane must be level for the unit to accurately indicate boom angles. Check the adjustment of the boom angle indicator daily to ensure its accuracy.

1. Park the crane on a firm level surface, shift the transmission to neutral, and engage the park brake.
2. Level the crane on fully extended outriggers. Position the upper over the front of the carrier and engage the travel swing lock. Fully retract the power sections of the boom. Boom down to 0° angle.
3. Verify the crane is level by placing a carpenter's level across the front of upper frame. Check levelness with the upper over the rear and over the side of the crane. Adjust the outriggers as necessary.
4. Once the crane is level, verify that the boom is at 0 degrees by placing carpenter's level on top of the boom. Refer to Figure 3–16. Adjust the boom as necessary.
5. If necessary, loosen the screw and adjust the angle indicator until the bubble within the vial is positioned under the 0° mark. Tighten the screw.

Table Of Contents

| | |
|--|------------|
| Boom | 4-1 |
| Auxiliary Lifting Sheave | 4-2 |
| Auxiliary Lifting Sheave Installation | 4-3 |
| Auxiliary Lifting Sheave Removal | 4-3 |
| Offset Lattice Fly | 4-5 |
| Safety Instructions | 4-5 |
| Offset Lattice Fly Sections Installation | 4-5 |
| Offset Lattice Fly Sections Removal | 4-7 |
| Changing The Fly Offset Angle | 4-9 |
| Storage Of The Fly Base Section From The Erected Position | 4-12 |
| Storage Of The Fly Base And Tip Sections From The Erected Position | 4-13 |
| Erection Of The Fly Base Section From The Stored Position | 4-15 |
| Erection Of The Fly Base And Tip Section From The Stored Position | 4-17 |
| Fly Extensions | 4-21 |
| 16 Ft (4.9m) Fly Extension | 4-22 |
| 16 Ft (4.9m) Fly Extension With Lifting Sheave | 4-22 |
| Installing/Adding Fly Extension(s) | 4-23 |
| Removing Fly Extension(s) | 4-23 |

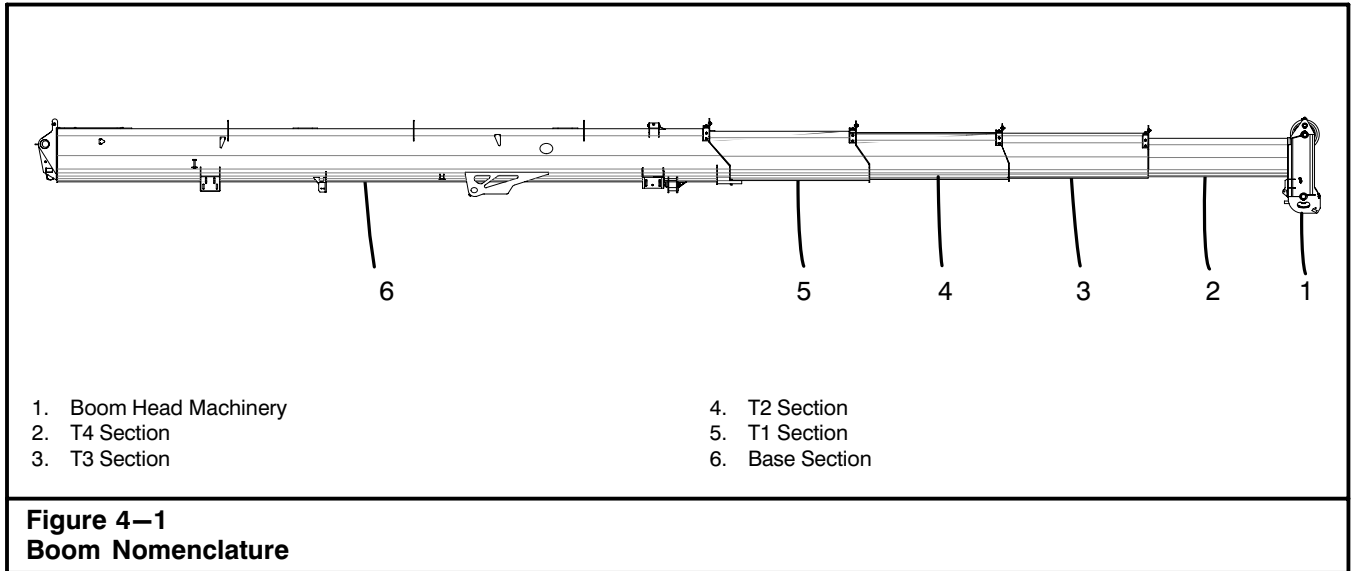

Boom

The boom is a five section full power latching boom. It consists of five basic parts: a base, T1, T2, T3, and a T4 section. Refer to Figure 4–1. The base section is con-

nected to the upper revolving frame. It is raised and lowered by the boom hoist cylinder. Refer to Section 1 of this Operator's Manual for boom operating instructions.

Operator's Manual

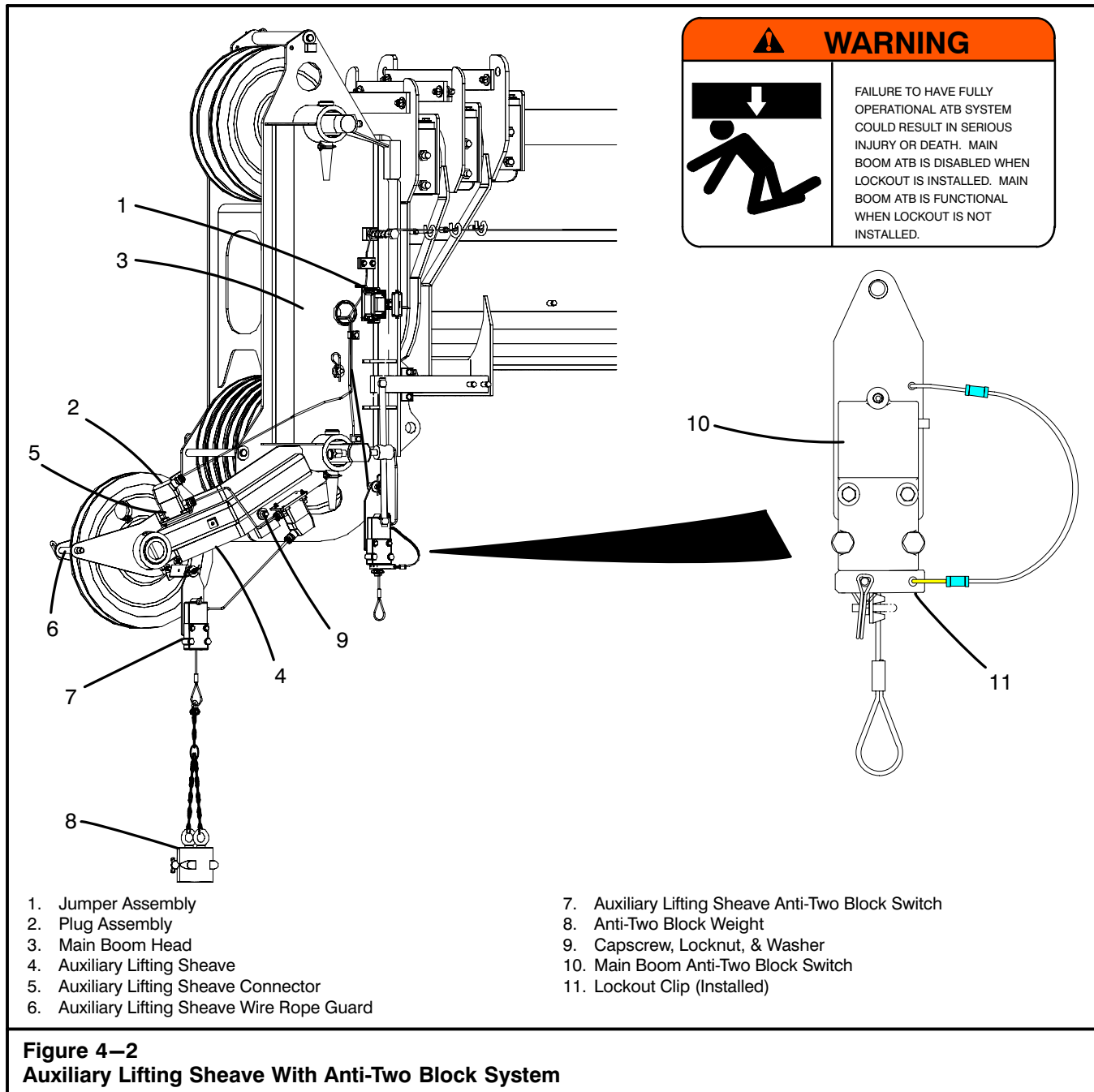

Auxiliary Lifting Sheave

The auxiliary lifting sheave connects to the boom head machinery. Refer to Figure 4-2. It is used for reeving winch wire rope for the second winch drum. Once installed, the unit may be left in place without interfering with the installation, erection, or storage of other boom attachments.



WARNING

The auxiliary lifting sheave adds weight to the boom which must be considered in lifting capacities. When making lifts from the main boom or fly with the auxiliary lifting sheave installed, refer to the Crane Rating Manual for the appropriate deductions from lifting capacities.

Operator's Manual

Auxiliary Lifting Sheave Installation

1. Park the crane on a firm, level surface, shift the transmission to neutral and apply the park brake.
2. Fully retract the boom and position the upper over the front of the carrier. Engage the travel swing lock.



WARNING

To avoid personal injury, do not climb, stand, or walk on the boom. Use a ladder or similar device as required to reach necessary areas.

3. Boom down and/or extend the boom, as required, to ease access to the head machinery.
4. Adequately support the auxiliary lifting sheave with an appropriate lifting device. It weighs approximately 110 lb (50kg). Position the auxiliary lifting sheave frame under the boom head cross shaft. Align the holes in the auxiliary lifting sheave frame with the lugs in the main boom and install capscrews, locknuts, and washers. Refer to Figure 4–2.
5. Remove the wire rope guard from the auxiliary lifting sheave. Reeve the winch wire rope on the boom deflector sheave, then over the sheave on the auxiliary lifting sheave. Install the wire rope guard.

CAUTION

All wire rope guards must be in proper position during operation.

6. Properly connect the anti-two block system as follows:
 - a. Disconnect plug assembly from jumper assembly on the main boom head and connect it to the auxiliary arm connector. Refer to Figure 4–2.
 - b. Install the anti-two block weight to the auxiliary lifting sheave anti-two block switch cable.
 - c. Properly install lockout clip on the main boom anti-two block switch weight cable.

Note: When the lockout clip is installed, the anti-two block switch is inactive.

When both main boom and auxiliary sheave are reeved for operation, the lockout clip must be removed and an anti-two block weight must be suspended from each anti-two block switch.

7. Properly set the Rated Capacity Limiter to the correct crane configuration. Refer to Section 1 of this Operator's Manual.

8. Check the Crane Rating Manual in the upper operator's cab for necessary deductions with the auxiliary lifting sheave installed before continuing operations.



WARNING

The auxiliary lifting sheave adds weight to the boom which must be considered in lifting capacities. When making lifts from the main boom or fly with the auxiliary lifting sheave installed, refer to the Crane Rating Manual for the appropriate deductions from lifting capacities.

Auxiliary Lifting Sheave Removal

1. Park the crane on a firm, level surface. Shift the transmission to neutral and engage park brake.
2. Fully retract the boom and position the upper over the front of the carrier. Engage travel swing lock.
3. Boom down and/or extend the boom, as required, to ease access to the head machinery.



WARNING

To avoid personal injury, do not climb, stand, or walk on the boom. Use a ladder or similar device to reach necessary areas.

4. Properly disconnect the anti-two block system as follows:
 - a. Disconnect the plug assembly from the auxiliary lifting sheave and connect it to the jumper assembly on the main boom head. Refer to Figure 4–2.
 - b. Remove the lockout clip from the main boom head anti-two block switch weight cable.
 - c. Remove the anti-two block weight from the auxiliary lifting sheave and install it on the main boom anti-two block switch.
5. Remove the wire rope guard from the auxiliary lifting sheave. Remove the winch wire rope and install the wire rope guard for storage.
6. Adequately support the auxiliary lifting sheave. It weighs approximately 110 lb (50kg). Remove the capscrews, locknuts, and washers. Remove the auxiliary lifting sheave. Refer to Figure 4–2.
7. Properly store the auxiliary lifting sheave, the capscrews, locknuts, and washers and the winch wire rope which was used on the auxiliary lifting sheave.
8. Properly set the Rated Capacity Limiter to the correct crane configuration. Refer to Section 1 of this Operator's Manual.

Operator's Manual

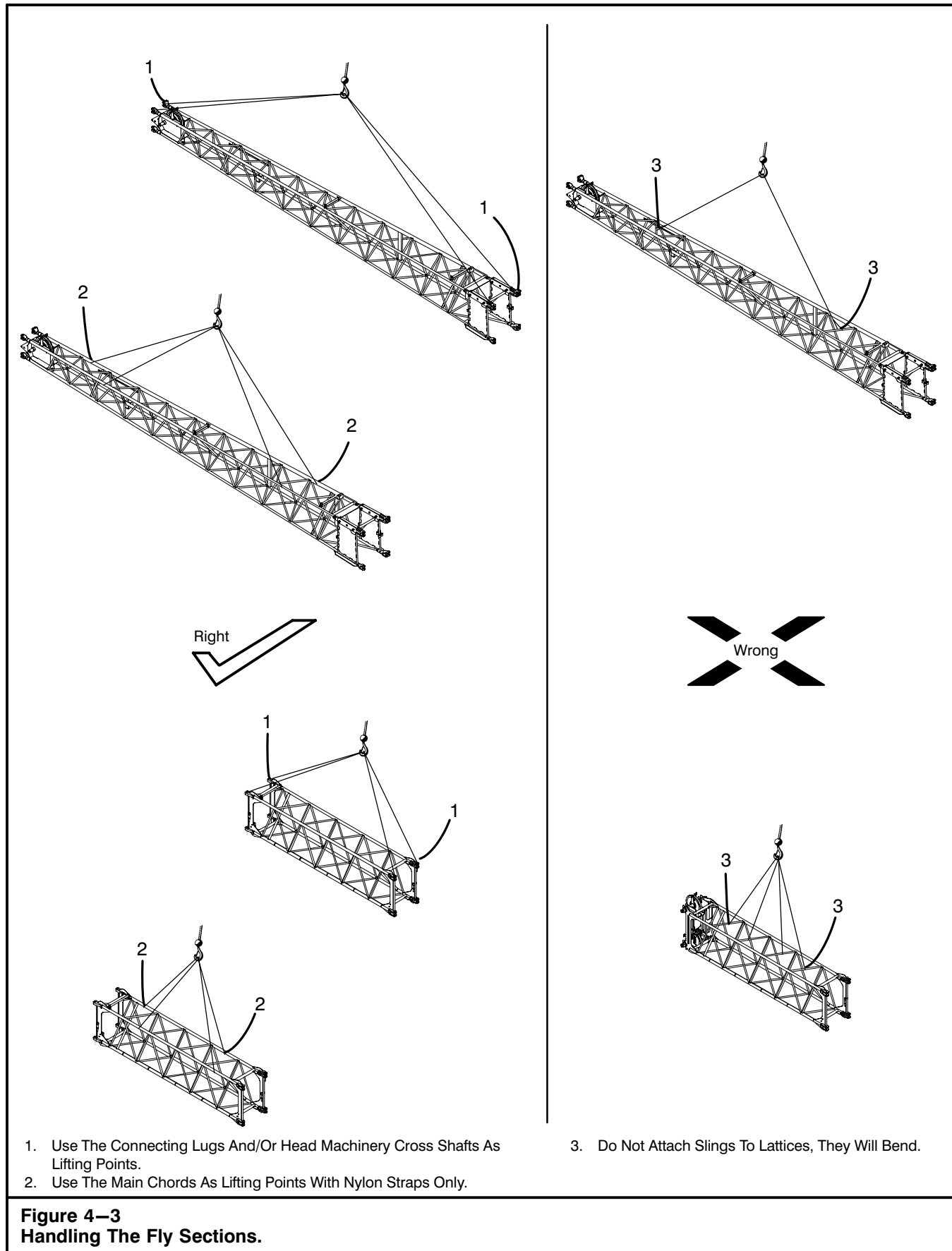

Offset Lattice Fly

The crane may be equipped with either a one or two piece offset lattice fly. The offset lattice fly section, as seen in Figure 4–4, connects to the main boom head. It can be mounted in one of four offset positions: 2°, 15°, 30°, or 45°. The fly extends the boom length for greater heights. The tip section of the fly extends its overall length from 35 ft (10.7m) to 58 ft (17.7m). Once installed, the offset lattice fly section(s) can be stored on the right side of the boom base section.

Safety Instructions

The following points must be observed while performing any fly assembly or disassembly:

1. Read and understand the instructions outlined in this Operator's Manual before attempting to assemble or disassemble the fly.
2. Do not stand inside, on top, or under the fly at any time while assembling or disassembling the fly.
3. To avoid personal injury, do not climb, stand, or walk on the fly. Use a ladder or similar device to reach necessary areas.
4. Use care handling the fly section(s) or extension(s) when loading, transporting, and unloading. Damage that occurs during these operations can go undetected and could result in failure of the attachment, once subjected to loading. Do not attach slings to the lattices, when lifting the fly, as they will bend. It is recommended that the connecting lugs and/or head machinery cross shaft be used as the lifting points. However, it is permissible to attach nylon straps around all four main chords. Refer to Figure 4–3.
5. Each individual fly section and/or extension must be adequately supported before attempting to disassemble the fly. Removing the connecting pins from the fly before it is supported, may allow the fly to fall.
6. Stay clear of pinch points when aligning fly section connecting points. Never place your fingers in connecting pin holes.
7. Fully assemble the fly before installing it on the boom.

Offset Lattice Fly Sections Installation

1. Park the crane on a firm, level surface, shift the transmission to neutral, and apply the park brake.
2. Level the crane on fully or intermediate extended outriggers with all tires clear of the ground.
3. Position the upper directly over the front of the carrier and engage the travel swing lock.



WARNING

Install the offset fly with the crane level on fully or intermediate extended outriggers, all tires clear of the ground, the upper directly over the front of the carrier, and the travel swing lock engaged.

The fly adaptor lug and offset connecting pins must be in the 2° offset position to remove, install, store, or erect the offset fly.

Refer to the Crane Rating Manual for the maximum boom length the fly can be raised/lowered to/from the ground.

Failure to do the above could result in the personal injury and/or the crane tipping.

4. Check that the fly adaptor lug and offset connecting pins are installed in the 2° offset position. Refer to Figure 4–6.
 5. Pin the fly base and tip together on secure blocking. Refer to Figure 4–5. The fly base section weighs approximately 1,600 lb (726kg) and the fly tip section approximately 700 lb (318kg).
- Note: Fly base section may be installed by itself if desired.**
6. Remove the winch wire rope from the main boom head machinery or the auxiliary lifting sheave, whichever is to be used on the fly, and lay it aside to prevent damage to it during installation of the fly.



WARNING

To avoid personal injury, do not climb, stand, or walk on the boom or fly. Use a ladder or similar device to reach necessary areas.

7. Lower the boom and extend it to the fly. Slowly raise or lower the boom to engage the fly lugs with the head machinery cross shafts.

Operator's Manual

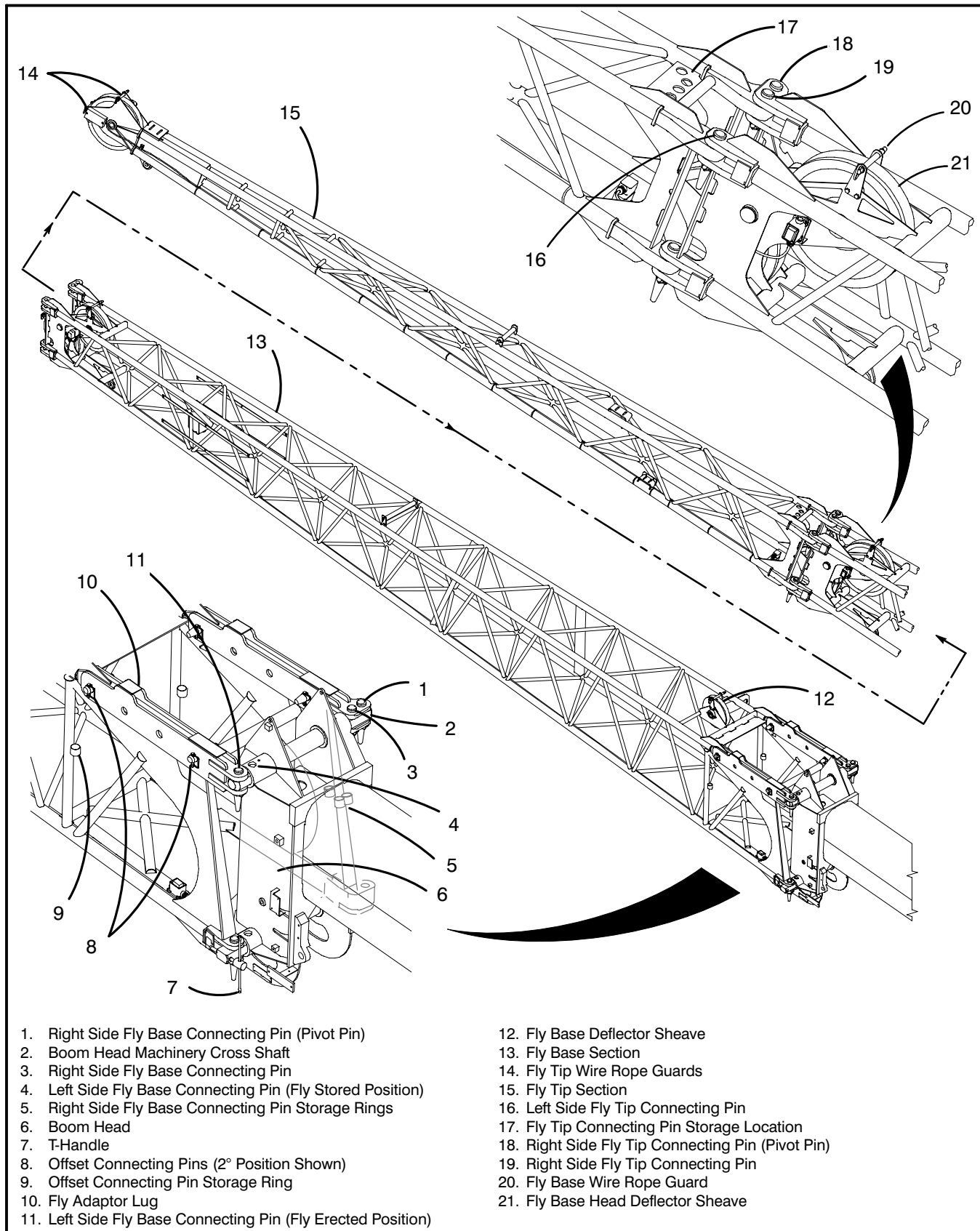

- | | |
|--|---|
| 1. Right Side Fly Base Connecting Pin (Pivot Pin) | 12. Fly Base Deflector Sheave |
| 2. Boom Head Machinery Cross Shaft | 13. Fly Base Section |
| 3. Right Side Fly Base Connecting Pin | 14. Fly Tip Wire Rope Guards |
| 4. Left Side Fly Base Connecting Pin (Fly Stored Position) | 15. Fly Tip Section |
| 5. Right Side Fly Base Connecting Pin Storage Rings | 16. Left Side Fly Tip Connecting Pin |
| 6. Boom Head | 17. Fly Tip Connecting Pin Storage Location |
| 7. T-Handle | 18. Right Side Fly Tip Connecting Pin (Pivot Pin) |
| 8. Offset Connecting Pins (2° Position Shown) | 19. Right Side Fly Tip Connecting Pin |
| 9. Offset Connecting Pin Storage Ring | 20. Fly Base Wire Rope Guard |
| 10. Fly Adaptor Lug | 21. Fly Base Head Deflector Sheave |
| 11. Left Side Fly Base Connecting Pin (Fly Erected Position) | |

Figure 4-4
Offset Lattice Fly Sections

Operator's Manual

8. Remove the four fly connecting pins from the storage rings at the rear of the fly base section. Refer to Figure 4–4. Install all four pins to connect the fly lugs to the head machinery cross shafts on the right side of the boom. (Install the pins with the head on top and keeper on the bottom.) Install the pin keepers.
9. Remove the two fly connecting pins from the boom head machinery cross shaft on the left side of the boom head. Refer to Figure 4–4. Install the top pin to connect the fly lug to the head machinery cross shaft on the left side of the boom head. Turn the t-handle as required to push and align the bottom left fly lug and the bottom boom head cross shaft. Install the bottom left fly connecting pin. (Install the pins with the head on top and keeper on the bottom.) Install the pin keepers. Back off the t-handle until at least a 1/2 in (1.3cm) clearance from the fly lug is obtained.



WARNING

All fly tip and base connecting pins must be properly installed before operating the crane with the fly erected. Damage to the fly or personal injury could occur if all connecting pins are not properly installed.

10. Remove the wire rope guards from the fly base and boom head deflector sheaves. Reeve the winch wire rope over the boom deflector sheave, then on the fly base deflector sheave.
11. Remove the wire rope guards from either the fly base or fly tip head sheaves, whichever is to be used. Reeve the winch wire rope over the appropriate head sheave and install the wire rope guards.

CAUTION

All wire rope guards must be in proper position during operation.

12. Properly connect anti-two block system as follows:
 - a. Disconnect plug assembly from jumper assembly on the main boom head and connect it to the offset lattice fly section connector.
 - b. Install the anti-two block weight on the offset lattice fly anti-two block switch cable.
 - c. Properly install lockout clip on the main boom anti-two block switch weight cable.

Note: When the lockout clip is installed, the anti-two block switch is inactive.

When both main boom and fly are reeved for operation, the lockout clip must be removed and an anti-two block weight must be suspended from each anti-two block switch.

13. Properly set the Rated Capacity Limiter to the correct crane configuration. Refer to Section 1 of this Operator's Manual.
14. Check the Crane Rating Manual, in the upper operator's cab, for deductions from the lifting capacities with the fly installed before continuing operations.



WARNING

The fly adds weight to the boom which must be considered in lifting capacities when the fly is erected. When making lifts from the main boom or auxiliary lifting sheave with the fly erected, refer to the Crane Rating Manual for the appropriate deductions from lifting capacities. Use the offset lattice fly only when the crane is level on fully or intermediate extended outriggers with all tires clear of the ground.

Offset Lattice Fly Sections Removal

1. Park the crane on a firm, level surface. Shift the transmission to neutral and engage the park brake.
2. Level the crane on fully or intermediate extended outriggers with all tires clear of the ground.
3. Position the upper directly over the front of the carrier and engage the travel swing lock.



WARNING

Remove the offset fly with the crane level on fully or intermediate extended outriggers, all tires clear of the ground, the upper directly over the front of the carrier, and the travel swing lock engaged.

The fly adaptor lug and offset connecting pins must be in the 2° offset position to remove, install, store, or erect the offset fly.

Refer to the Crane Rating Manual for the maximum boom length the fly can be raised/lowered to/from the ground.

Failure to do the above could result in the personal injury and/or the crane tipping.

Operator's Manual

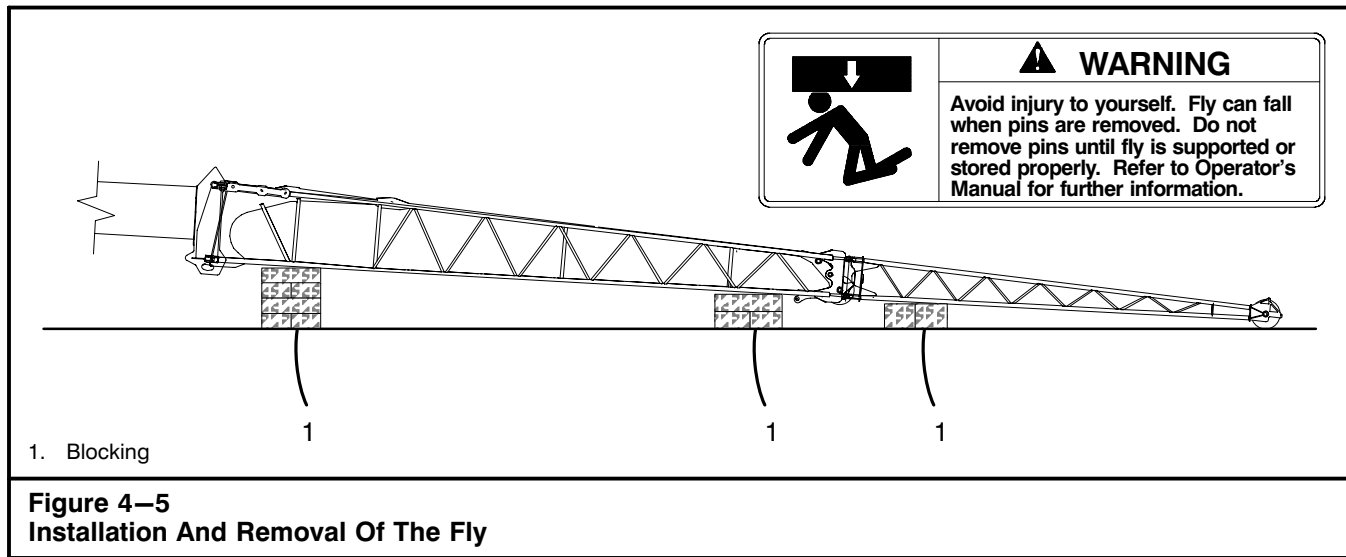

4. If the fly is not in the erected position, erect it per “[Erection Of The Fly Base And Tip Sections From The Stored Position](#)” in this Section of this Operator's Manual.
5. Check that the fly adaptor lug and offset connecting pins are installed in the 2° offset position. Refer to Figure 4–6. If necessary, change the fly offset to the 2° position. Refer to “[Changing The Fly Offset](#)” in this Section of this Operator's Manual for detailed instructions.
6. Boom down fully.
7. Remove all fly base and tip wire rope guards. Remove boom head and deflector sheave wire rope guards and lay the winch wire rope aside.

WARNING
To avoid personal injury, do not climb, stand, or walk on the boom or fly. Use a ladder or similar device to reach necessary areas.

8. Install all fly base and tip wire rope guards at the deflector and head sheaves. Install the boom head and deflector sheave wire rope guards.
9. Extend the boom until the fly tip sheave rests on the ground.
10. Securely block up the fly sections to support it. Refer to Figure 4–5. The fly base section weighs approximately 1,600 lb (726kg) and the fly tip section approximately 700 lb (318kg).

WARNING
Use extreme care when removing the tapered fly connecting pins. They could pop out suddenly and cause personal injury.

11. Remove the six fly connecting pins and store four of the pins and keepers in the storage rings at the rear of the fly. Install the remaining two pins and keepers in the storage holes on the left side of the boom head machinery cross shafts to prevent the shaft from rotating. Refer to Figure 4–4.

Note: If only the fly tip section is to be removed, remove the connecting pins from the fly tip lugs only.

12. Retract the boom away from the fly.
13. Properly reeve or secure the winch wire rope which was used on the fly.
14. Properly connect the anti-two block system as follows:
 - a. Remove the lockout clip from the main boom anti-two block switch weight cable. Refer to Figure 4–2.
 - b. Remove the anti-two block weight from the offset lattice fly and install it on the main boom head anti-two block switch.
 - c. Remove the plug assembly from the offset lattice fly and connect it to the jumper assembly on the main boom head.
15. Properly set the Rated Capacity Limiter to the correct crane configuration. Refer to Section 1 of this Operator's Manual.
16. Properly store fly section to prevent damage to it.

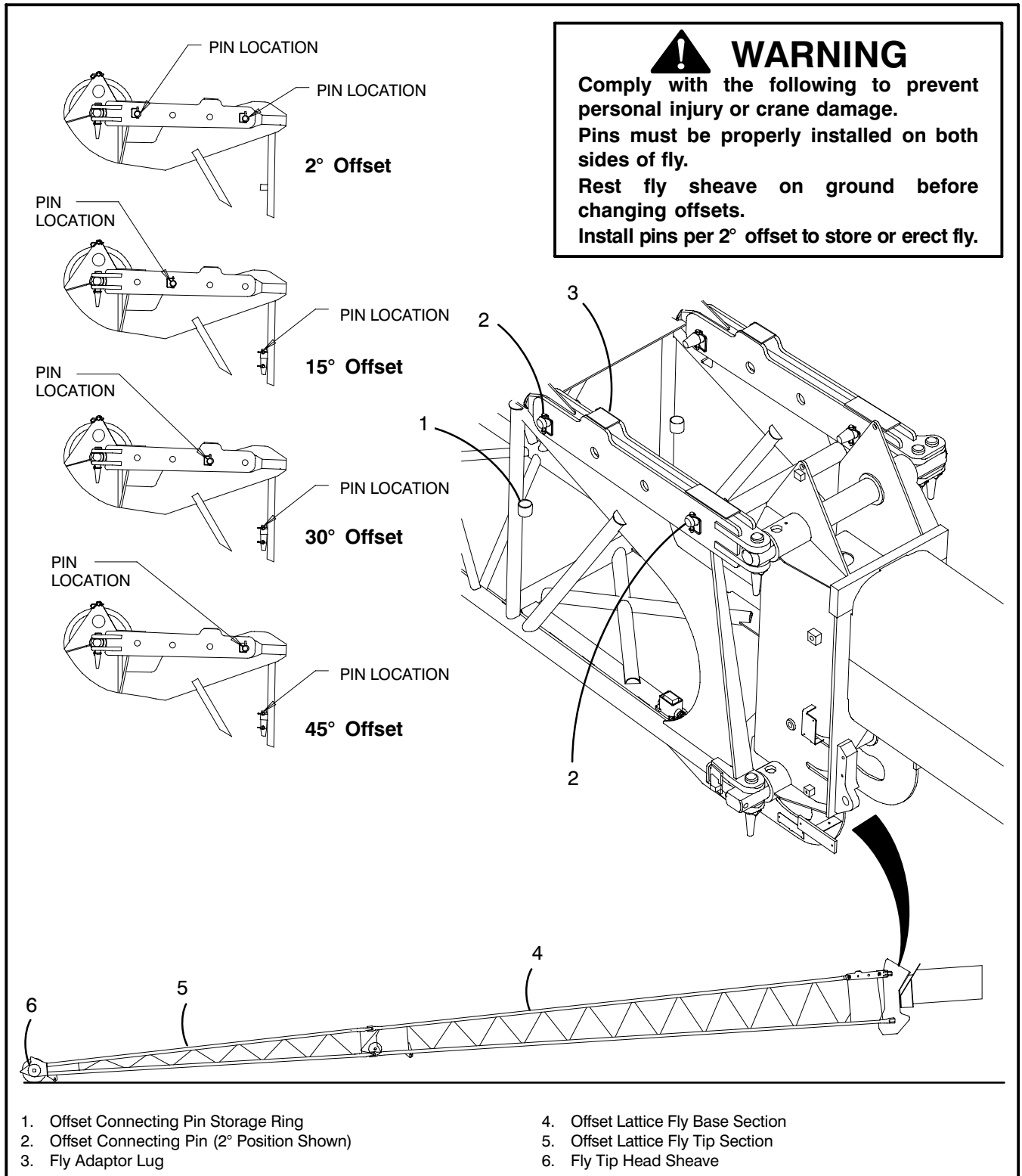

Figure 4–6
Changing The Fly Offset Angle

Changing The Fly Offset Angle

1. Park the crane on a firm, level surface, shift the transmission to neutral, and apply the park brake.

2. Level the crane on fully or intermediate extended outriggers with all tires clear of the ground.

Operator's Manual

3. Position the upper directly over the front of the carrier and engage the travel swing lock.



WARNING

Change the fly offset angle with the crane level on fully or intermediate extended outriggers with all tires clear of the ground, the upper directly over the front of the carrier, and the travel swing lock engaged.

The fly adaptor lug and offset connecting pins must be in the 2° offset position to remove, install, store, or erect the offset fly.

Refer to the Crane Rating Manual for the maximum boom length the fly can be raised/lowered to/from the ground.

Failure to do the above could result in personal injury and/or the crane tipping.

4. If the offset lattice fly section is not in the erected position, erect it per "Erection Of The Fly From The Stored Position" in this Section of this Operator's Manual.
5. Carefully extend and/or lower the boom until the fly tip head sheave is resting on the ground. Use a signalman to alert the operator when the sheave is resting on the ground.

Note: If the crane is not equipped with the fly tip section or the fly tip section is not erected, lower the fly base section until the fly base head sheave is resting on the ground.

CAUTION

Do not extend the boom or boom down to the point of over stressing the offset lattice fly section. Structural damage to the fly could occur if care is not taken. Use a signalman to aid the operator in lowering the fly head sheave to the ground.

6. Remove the offset connecting pins from the fly adaptor lugs as required.
7. Install the offset connecting pins in the correct location for the desired offset angle. Use the information label, on the offset lattice fly section, to determine the correct offset connecting pin locations for the desired offset angle of the fly. Refer to Figure 4–6.
8. Ensure to properly locate the offset connecting pins on both sides of the fly and ensure that the keeper pins are securely installed.
9. Slowly boom up to allow the fly section to adjust itself to the desired offset angle.
10. Properly set the Rated Capacity Limiter to the correct crane configuration before continuing operations. Refer to Section 1 of this Operator's Manual.
11. Check the Crane Rating Manual, in the operator's cab, for deductions from the lifting capacities with the fly installed before continuing operations.



WARNING

The fly adds weight to the boom which must be considered in lifting capacities when the fly is erected. When making lifts from the main boom or auxiliary lifting sheave with the fly erected, refer to the Crane Rating Manual for the appropriate deductions from lifting capacities. Use the offset lattice fly only when the crane is level on fully or intermediate extended outriggers with all tires clear of the ground.

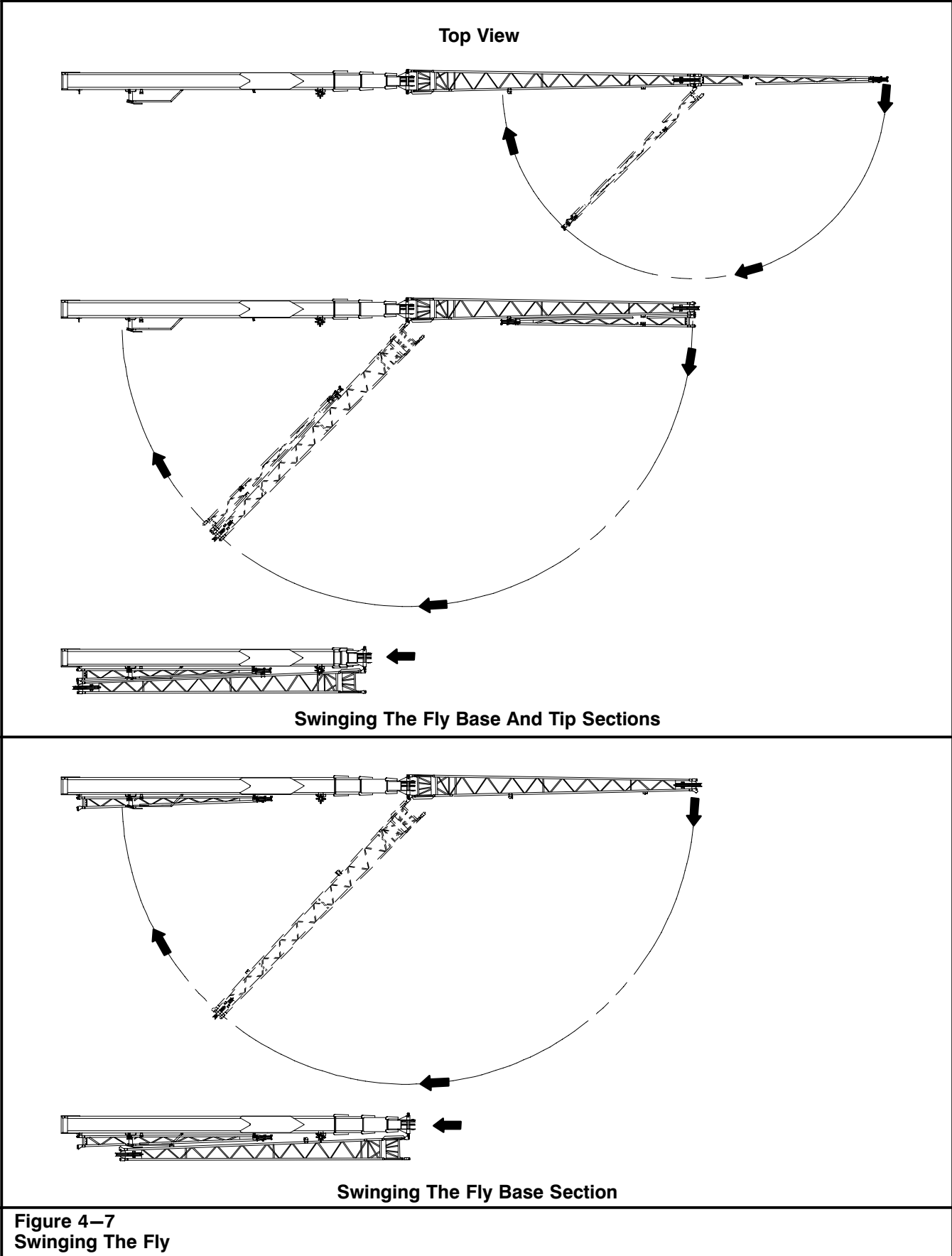

Operator's Manual

Storage Of The Fly Base Section From The Erected Position

1. Park crane on a firm, level surface. Shift the transmission to neutral and engage the park brake.
2. Level the crane on fully or intermediate extended outriggers with all tires clear of the ground.
3. Position the upper directly over the front of the carrier and engage the travel swing lock.



WARNING

Store the fly with the crane level on fully or intermediate extended outriggers with all tires clear of the ground, the upper directly over the front of the carrier, and the travel swing lock engaged.

The fly adaptor lug and offset connecting pins must be in the 2° offset position to remove, install, store, or erect the offset fly.

Refer to the Crane Rating Manual for the maximum boom length the fly can be raised/lowered to/from the ground.

Failure to do the above could result in the personal injury and/or the crane tipping.

4. Check that the offset connecting pins (2) are installed in the 2° offset position. Refer to Figure 4–6. If necessary change the fly offset to the 2° position. Refer to “[Changing The Fly Offset Angle](#)” in this Section of this Operator's Manual for detailed instructions.
5. Position the boom above 50° boom angle and fully retract the boom.



WARNING

To avoid personal injury, do not climb, stand, or walk on the boom or fly. Use a ladder or similar device to reach necessary areas.

6. Lower the boom to 0° boom angle.
7. Properly connect the anti-two block system as follows:
 - a. Disconnect plug assembly from fly and connect it to the jumper assembly on the main boom head.
 - b. Remove lockout clip from main boom head anti-two block switch cable.
 - c. Remove the anti-two block weight from the fly base section and install it on the main boom anti-two block switch.

8. Remove wire rope guards from fly base head sheave, fly base deflector sheave, the boom head sheave and boom deflector sheave. Refer to Figure 4–4. Remove the winch wire rope and lay it aside. Install wire rope guards at all sheaves for storage.
9. Properly store winch wire rope which was used on fly.
10. Attach a hand line to the tip of the fly base.



WARNING

Do not remove the fly connecting pivot pins on the right side of the boom until the fly is pinned to the storage brackets. The fly could fall causing crane damage and/or personal injury.

Use extreme care when removing the tapered fly connecting pins. They could pop out suddenly causing personal injury.

11. Remove the bottom left fly base connecting pin on the left side of the fly using the t-handle to assist in relieving the load on the pin. Back off the t-handle until at least a 1/2 in (1.3cm) clearance from the fly lug is obtained. Remove the top left fly base connecting pin. Store connecting pins in the storage holes on the boom head cross shafts (2) on the left side of the boom.
12. Remove the inside bottom right fly base connecting pin on the right side of the fly. To reduce loading and ease pin removal, push the fly to the right. Refer to Figure 4–4. Remove the inside top right fly base connecting pin on the right side of the fly. To reduce loading and ease pin removal push the fly to the left. Store the two pins and keepers in the storage rings (5) on the rear picture frame of the fly base section (13).
13. Boom up to 2° boom angle.



WARNING

Use a hand line to control fly swing. Fly could swing around the boom rapidly. Keep all personnel clear of swing path to avoid injury.

14. Slowly swing the fly base section around to the right side of the boom. Slowly boom up to 50°. Refer to Figure 4–7.
15. Extend the boom until the fly can swing completely against the storage bracket.

16. Slowly retract the boom while maintaining 50° boom angle to slide the storage lug on the rear of the fly base into the slot on the rear storage bracket (10). Refer to Figure 4–11. At the same time, the lug on the front storage bracket (15) should engage through the hole on the rear of the fly base.
17. Boom down low enough to reach connecting pins. Pull down and rotate retaining pin (16). Push retaining pin up to engage the pin through the lug on the front storage bracket (15) then rotate the pin to the engaged position.



WARNING

Do not remove the fly connecting pivot pins on the right side of the boom until the fly is pinned to the storage brackets. The fly could fall causing crane damage and/or personal injury.

18. Remove two fly base connecting pivot pins (1) from the right side of the boom. Refer to Figure 4–4. Store pins and keepers in storage rings (5) on the rear picture frame of the fly base section (13).

CAUTION

Before operating or traveling the crane ensure the right side fly connecting pins are properly stored in their storage rings, and the left side connecting pins are stored in their storage holes in the boom head cross shafts. Damage could result to the fly and/or boom if fly connecting pins are not properly stored.

19. Properly set the Rated Capacity Limiter to the correct crane configuration. Refer to Section 1 of this Operator's Manual.
20. Check the Crane Rating Manual for lifting capacities with the fly in the stored position before continuing operations.

Storage Of The Fly Base And Tip Sections From The Erected Position

1. Park crane on a firm, level surface, shift the transmission to neutral, and apply the park brake.
2. Level the crane on fully or intermediate extended outriggers with all tires clear of the ground.
3. Position the upper directly over the front of the carrier and engage the travel swing lock.



WARNING

Store the fly with the crane level on fully or intermediate extended outriggers with all tires clear of the ground, the upper directly over the front of the carrier, and the travel swing lock engaged.

The fly adaptor lug and offset connecting pins must be in the 2° offset position to remove, install, store, or erect the offset fly.

Refer to the Crane Rating Manual for the maximum boom length the fly can be raised/lowered to/from the ground.

Failure to do the above could result in the personal injury and/or the crane tipping.

4. Check that the offset connecting pins (2) are installed in the 2° offset position. Refer to Figure 4–6. If necessary change the fly offset to the 2° position. Refer to “[Changing The Fly Offset Angle](#)” in this Section of this Operator's Manual for detailed instructions.
5. Position the boom above 50° boom angle and fully retract the boom.



WARNING

To avoid personal injury, do not climb, stand, or walk on the boom or fly. Use a ladder or similar device to reach necessary areas.

6. Lower the boom to 0° boom angle.
7. Properly connect the anti-two block system as follows:
 - a. Disconnect plug assembly from fly and connect it to the jumper assembly on the main boom head.
 - b. Remove lockout clip from main boom head anti-two block switch cable.
 - c. Remove the anti-two block weight from the fly section and install it on the main boom anti-two block switch.
8. Remove wire rope guards from fly tip head sheave, fly base head sheave, fly base deflector sheave, the boom head sheave and boom deflector sheave. Refer to Figure 4–4. Remove the winch wire rope and lay it aside. Install wire rope guards at all sheaves for storage.

Operator's Manual

⚠ WARNING

Comply with the following to prevent personal injury or machine damage.

Stored Fly Tip: (shown)
Install one pin in top left side lug closest to boom.
Install other 5 pins in storage.
Refer to Operator's Manual for detailed instructions.

Fly Tip Stored on Boom

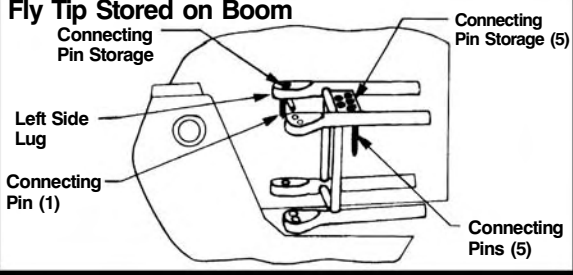

The diagram shows a fly tip assembly mounted on a boom. Labels include: 'Left Side Lug' pointing to a circular hole on the left; 'Connecting Pin Storage' pointing to a bracket on the boom; 'Connecting Pin (1)' pointing to a pin inserted into the lug; 'Connecting Pin Storage (5)' pointing to a bracket on the boom; and 'Connecting Pins (5)' pointing to five pins inserted into the boom's cross shafts.

Figure 4–8
Fly Tip Storage Label

9. Properly store winch wire rope which was used on fly.
10. Attach a hand line to the tip of the fly tip section.

⚠ WARNING

Do not remove fly tip connecting pivot pins on the right side of the fly until the fly is pinned to the storage brackets. Fly tip could fall causing crane damage and/or personal injury.

Use extreme care when removing the tapered fly connecting pins. They could pop out suddenly causing personal injury.

11. Remove the bottom and then the top fly tip connecting pins (16) on the left side of the fly tip section (15). Refer to Figure 4–4. To ease pin removal, relieve the loading on the pins by pushing the fly tip from side to side. Store pins and keepers in the storage location (17) on the rear of the fly tip section.
12. Remove the inside bottom right fly tip connecting pin on the right side of the fly tip section. To reduce loading and ease pin removal, push the fly tip to the right. Refer to Figure 4–4. Remove the inside top right fly tip connecting pin on the right side of the fly tip section. To reduce loading and ease pin removal push the fly tip to the left. Store pins and keepers in the storage location (17) on the rear of the fly tip section.

⚠ WARNING

Use a hand line to control fly swing. Fly tip could swing around fly base rapidly. Keep all personnel clear of swing path to avoid injury.

13. Using the hand line attached to the fly tip section, slowly swing the fly tip section around to the right side of the fly base section. Refer to Figure 4–7. Slowly boom up if necessary to ease fly tip swing.
14. Align the storage bracket on the fly tip section with the storage bracket on the fly base section. Refer to Figure 4–11. Install the hitch pin (12) through the storage brackets and secure the hitch pin.

⚠ WARNING

Do not remove the fly connecting pivot pins on the right side of the boom until the fly is pinned to the storage brackets. The fly could fall causing crane damage and/or personal injury.

Use extreme care when removing the tapered fly connecting pins. They could pop out suddenly causing personal injury.

15. Remove the bottom left fly base connecting pin on the left side of the fly using the t-handle to assist in relieving the load on the pin. Back off the t-handle until at least a 1/2 in (1.3cm) clearance from the fly lug is obtained. Remove the top left fly base connecting pin. Store connecting pins in the storage holes (4) on the boom head cross shafts (2) on the left side of the boom. Refer to Figure 4–4.
16. Remove the inside bottom right fly base connecting pin on the right side of the fly. To reduce loading and ease pin removal, push the fly to the right. Refer to Figure 4–4. Remove the inside top right fly base connecting pin on the right side of the fly. To reduce loading and ease pin removal push the fly to the left. Store the two pins and keepers in the storage rings (5) on the rear picture frame of the fly base section (13).
17. Boom up to 2° boom angle.

⚠ WARNING

Use a hand line to control fly swing. Fly could swing around the boom rapidly. Keep all personnel clear of swing path to avoid injury.

Operator's Manual

18. Slowly swing the fly base and tip sections around to the right side of the boom while slowly booming up to 50°. Refer to Figure 4–7.
19. Extend the boom until the fly can swing completely against the storage bracket.
20. Slowly retract the boom while maintaining 50° boom angle to slide the storage lug on the rear of the fly base into the slot on the rear storage bracket (10). Refer to Figure 4–11. At the same time, the lug on the front storage bracket (15) should engage through the hole on the rear of the fly base.
21. Boom down low enough to reach connecting pins. Pull down and rotate retaining pin (16). Push retaining pin up to engage the pin through the lug on the front storage bracket (15) then rotate the pin to the engaged position.



WARNING

Do not remove the fly connecting pivot pins on the right side of the boom until the fly is pinned to the storage brackets. The fly could fall causing crane damage and/or personal injury.

22. Remove two fly base connecting pivot pins (1) from the right side of the boom. Refer to Figure 4–4. Store pins and keepers in storage rings (5) on the rear picture frame of the fly base section (13).

CAUTION

Before operating or traveling the crane ensure the right side fly connecting pins are properly stored in their storage rings, and the left side connecting pins are stored in their storage holes in the boom head cross shafts. Damage could result to the fly and/or boom if fly connecting pins are not properly stored.

23. Properly set the Rated Capacity Limiter to the correct crane configuration. Refer to Section 1 of this Operator's Manual.
24. Check the Crane Rating Manual for lifting capacities with the fly in the stored position before continuing operations.

Erection Of The Fly Base Section From The Stored Position

1. Park crane on a firm, level surface, shift the transmission to neutral, and apply the park brake.
2. Level the crane on fully or intermediate extended outriggers with all tires clear of the ground.

3. Position the upper directly over the front of the carrier and engage the travel swing lock.



WARNING

Erect the fly with the crane level on fully or intermediate extended outriggers with all tires clear of the ground, the upper directly over the front of the carrier, and the travel swing lock engaged.

The fly adaptor lug and offset connecting pins must be in the 2° offset position to remove, install, store, or erect the offset fly.

Refer to the Crane Rating Manual for the maximum boom length the fly can be raised/lowered to/from the ground.

Failure to do the above could result in the personal injury and/or the crane tipping.

4. Check that the offset connecting pins (2) are installed in the 2° offset position. Refer to Figure 4–6. If necessary change the fly offset to the 2° position. Refer to “[Changing The Fly Offset Angle](#)” in this Section of this Operator's Manual for detailed instructions.
5. Check that the fly tip connecting pins are in the stored position. Refer to Figure 4–11.
6. Position the boom above 50° boom angle. Extend the boom to at least 62 ft (19m) and lower the hook block or hook ball, to be used on the fly, to the ground. This will allow enough wire rope length to ease reeving of the fly.
7. Retract the boom to engage the fly lugs with the head machinery cross shafts on the right side of the boom. Fully lower the boom.
8. Remove two fly connecting pins from the storage rings on the rear fly picture frame on the fly base section. Install them through the fly pivot lugs (18) on the right side of the boom. Refer to Figure 4–11. (Install the pins with the head on top and the keeper on the bottom.) Install the pin keepers.



WARNING

To avoid personal injury, do not climb, stand, or walk on the boom or fly. Use a ladder or similar device to reach necessary areas.

9. Remove the winch wire rope from the head machinery or the auxiliary lifting sheave whichever is to be used on the fly and lay it aside to prevent damage to it during erection of the fly.

Operator's Manual

WARNING

Comply with the following to prevent personal injury or machine damage.

Connecting Pins must be properly installed in both top and bottom lugs, as follows:

Lifting Loads:

Install pins in working position (as shown).
Verify pin placement on opposite side of boom below lifting loads.

Fly Not Erected: Install pins in boom headshaft storage to prevent headshafts from turning.

Refer to Operator's Manual for detailed instructions.

Fly Base Connecting Pin Placement

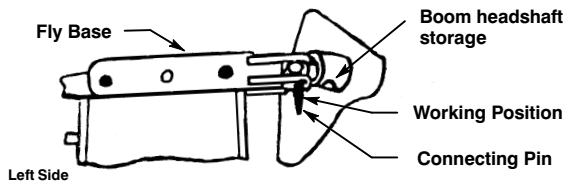

Figure 4–9
Left Side Fly Base Connecting Pin Label

WARNING

Check that the fly base connecting pins are installed on the right side of the boom in the pivot holes before disconnecting the fly from the storage brackets. The fly could fall causing crane damage and/or personal injury.

10. Pull down the retaining pin (17) to disengage the pin from the lug on the front storage bracket. Rotate and release the retaining pin to lock it in the disengaged position.
11. Attach a hand line to the tip of the fly base and boom up to 20°. Slowly extend the boom approximately 2–3 ft (0.61–1.0m) to slide the fly off the storage brackets.
12. Slowly boom down to allow the fly to swing out slightly from the storage brackets and then fully retract the boom.

CAUTION

Fully retract the boom before swinging the fly. Failure to do so could cause crane damage.

13. Continue to lower the boom to 2° angle to swing the fly base around the boom head until the fly lugs engage with the cross shafts on the left side of the boom. Refer to Figure 4–7.

WARNING

Use a hand line to control fly swing. The fly could swing around the boom rapidly. Keep all personnel clear of the swing path to avoid injury.

14. Remove the two connecting pins from the storage rings (11) on the rear fly picture frame on the fly base section and install them in the cross shafts (23) on the right side of the boom. Refer to Figure 4–11. Install the inside top right pin first. Swing the fly base to the left to get the pin to drop in the hole. Install the inside bottom right pin. Swing the fly base to the right to get the pin to drop in the hole. (Install the pins with the head on top and the keeper on the bottom.) Install the pin keepers.
15. Remove the two fly connecting pins from the storage location (24) on the boom head machinery cross shaft on the left side of the boom. Refer to Figure 4–11. Install one left side fly base connecting pin (21) through the top fly lug on the left side of the boom. Turn the t-handle to push and align the bottom left fly lug and the bottom boom head cross shaft. Install the bottom left fly connecting pin. (Install the pins with the head on top and the keeper on the bottom.) Install the pin keepers. Back off the t-handle until at least a 1/2 in (1.3cm) clearance from the fly lug is obtained.

WARNING

All six fly base connecting pins must be properly installed before operating the crane with the fly base erected. Damage to the fly or personal injury could occur if all connecting pins are not properly installed.

16. Remove the wire rope guard from the fly base head and deflector sheaves. Refer to Figure 4–4. Reeve the winch wire rope on the boom deflector sheave then over the fly deflector and head sheaves. Install all wire rope guards.

CAUTION

All wire rope guards must be in proper position during operation.

17. Properly connect the anti-two block system as follows:
 - a. Disconnect the plug assembly from the jumper assembly on main boom head and connect it to the fly base section.
 - b. Install the anti-two block weight. Refer to Section 1 of this Operator's Manual.
 - c. Properly install lockout clip on main boom head anti-two block switch cable.

Note: When lockout clip is installed, the anti-two block switch is inactive.

When both main boom and fly are reeved for operation, the lockout clip must be removed and an anti-two block weight must be suspended from each anti-two block switch.

18. Properly set the Rated Capacity Limiter to the correct crane configuration. Refer to Section 1 of this Operator's Manual.
19. Check the Crane Rating Manual for lifting capacities with the fly installed before continuing operations.

WARNING

The fly adds weight to the boom which must be considered in lifting capacities when the fly is erected. When making lifts from the main boom or auxiliary lifting sheave with the fly erected, refer to the Crane Rating Manual for the appropriate deductions from lifting capacities. Use the offset lattice fly only when the crane is level on fully or intermediate extended outriggers with all tires clear of the ground.

Erection Of The Fly Base And Tip Section From The Stored Position

1. Park crane on a firm, level surface. Shift the transmission to neutral and engage the park brake.
2. Level the crane on fully or intermediate extended outriggers with all tires clear of the ground.

 **WARNING**

Comply with the following to prevent personal injury or machine damage.

Connecting Pins must be properly installed in both top and bottom lugs, as follows:

Lifting Loads:
Install 2 pins in each right side lug (total of 4 pins on right side.)

Fly Not Erected:
Install pins in storage tubes on fly. Refer to Operator's Manual for detailed instructions.

Fly Base Connecting Pin Placement

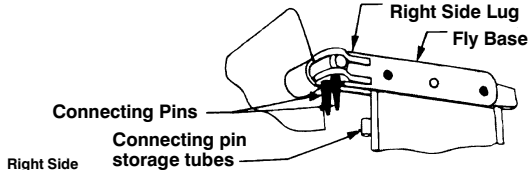

**Figure 4–10
Right Side Fly Base Connecting Pin Label**

WARNING

Erect the fly with the crane level on fully or intermediate extended outriggers with all tires clear of the ground, the upper directly over the front of the carrier, and the travel swing lock engaged.

The fly adaptor lug and offset connecting pins must be in the 2° offset position to remove, install, store, or erect the offset fly.

Refer to the Crane Rating Manual for the maximum boom length the fly can be raised/lowered to/from the ground.

Failure to do the above could result in the personal injury and/or the crane tipping.

3. Position the upper directly over the front of the carrier and engage the travel swing lock.
4. Check that the offset connecting pins (2) are installed in the 2° offset position. Refer to Figure 4–6. If necessary change the fly offset to the 2° position. Refer to "[Changing The Fly Offset Angle](#)" in this Section of this Operator's Manual for detailed instructions.
5. Position the boom above 50° boom angle. Extend the boom to at least 86 ft (26m) and lower the hook block or hook ball, to be used on the fly, to the ground. This will allow enough wire rope length to ease reeving of the fly.
6. Retract the boom to engage the fly lugs with the head machinery cross shafts on the right side of the boom. Fully lower the boom.

Operator's Manual

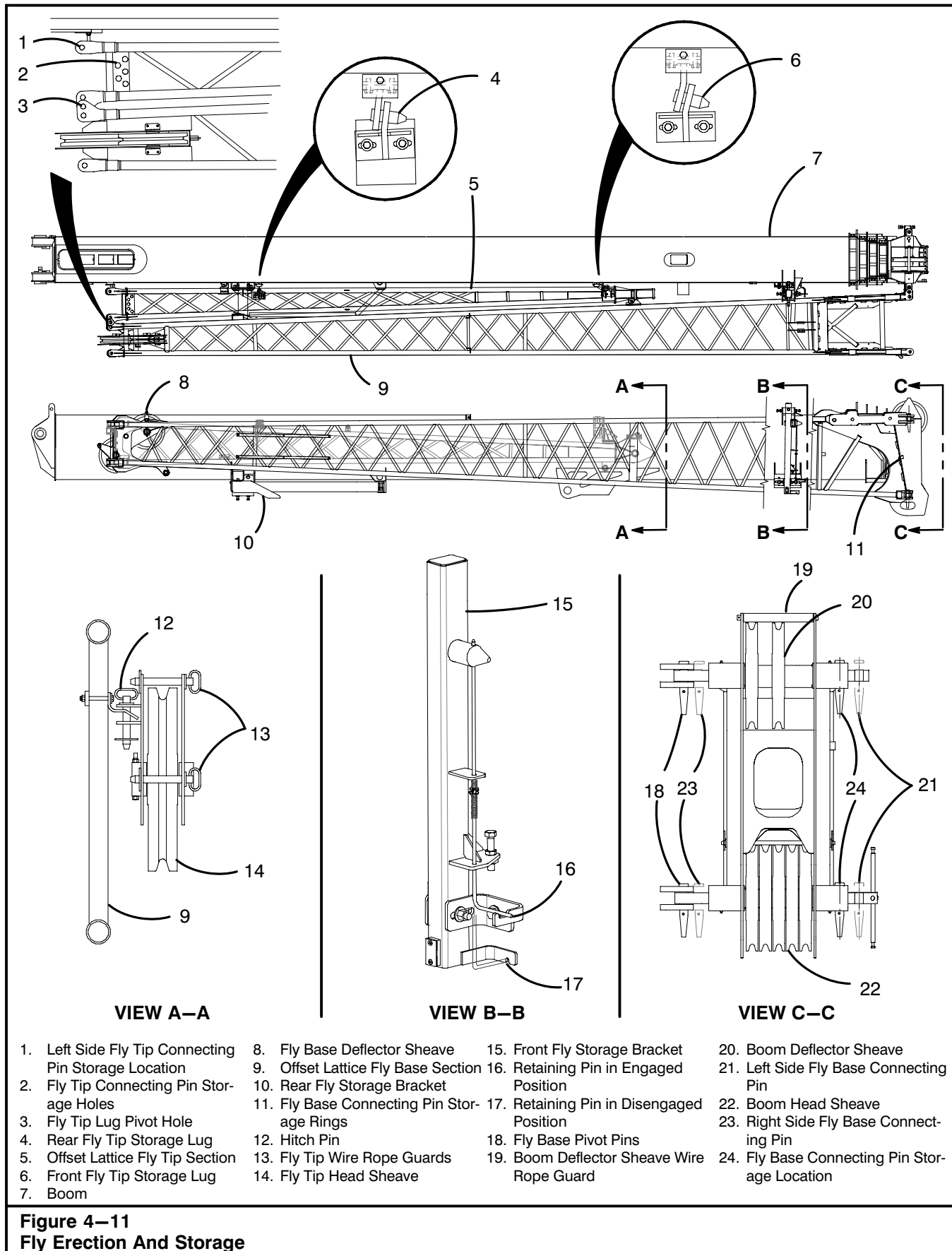

Figure 4-11
Fly Erection And Storage

Operator's Manual

7. Remove two fly connecting pins from the storage rings (11) on the rear fly picture frame on the fly base section. Install them through the fly base pivot lugs (18) on the right side of the boom. Refer to Figure 4–11. (Install the pins with the head on top and the keeper on the bottom.) Install the pin keepers.
8. Remove the connecting pin and keeper from the top fly tip connecting lug (1) on the left side of the fly tip section. Remove another fly tip connecting pin from the storage hole (2) on the rear of the fly tip section. Refer to Figure 4–11. Install them through the fly tip pivot lugs (3). (Install the pins with the head on top and the keeper on the bottom.) Install the pin keepers.



WARNING

To avoid personal injury, do not climb, stand, or walk on the boom or fly. Use a ladder or similar device to reach necessary areas.

9. Remove the winch wire rope from the head machinery or the auxiliary lifting sheave whichever is to be used on the fly and lay it aside to prevent damage to it during erection of the fly.
10. Check that the hitch pin (12) is installed through the lugs on the fly tip and base sections.



WARNING

Check that the fly base and tip connecting pins are installed in the pivot holes before disconnecting the fly from the storage brackets. Also check that the hitch pin is installed through the lugs on the fly tip and base sections. The fly could fall causing crane damage and/or personal injury.

11. Pull down the retaining pin (17) to disengage the pin from the lug on the front storage bracket. Refer to Figure 4–11. Rotate and release the retaining pin to lock it in the disengaged position.
12. Attach a hand line to the tip of the fly base and boom up to 20°. Slowly extend the boom approximately 2–3 ft (0.61–1.0m) to slide the fly base off the storage brackets.



WARNING

Use a hand line to control fly swing. The fly could swing around the boom rapidly. Keep all personnel clear of the swing path to avoid injury.

13. Slowly boom down to allow the fly to swing slightly out from the storage brackets and then fully retract the boom.

CAUTION

Fully retract the boom before swinging the fly. Failure to do so could cause crane damage.

14. Continue to lower the boom to 0° angle to swing the fly base and tip around the boom head until the fly lugs engage with the cross shafts on the left side of the boom. Refer to Figure 4–7.
15. Remove the two connecting pins from the storage rings (11) on the rear fly picture frame on the fly base section and install them in the cross shafts (23) on the right side of the boom. Install the inside top right pin first. Swing the fly base to the left to get the pin to drop in the hole. Install the inside bottom right pin. Swing the fly base to the right to get the pin to drop in the hole. (Install the pins with the head on top and the keeper on the bottom.) Install the pin keepers.
16. Remove the two fly connecting pins from the storage location (24) on the boom head machinery cross shaft on the left side of the boom. Refer to Figure 4–11. Install one pin through the top fly lug (21) on the left side of the boom. Turn the t-handle to push and align the bottom left fly lug and the bottom boom head cross shaft. Install the bottom left fly connecting pin. (Install the pins with the head on top and the keeper on the bottom.) Install the pin keepers. Back off the t-handle until at least a 1/2 in (1.3cm) clearance from the fly lug is obtained.



WARNING

All six fly base connecting pins must be properly installed before operating the crane with the fly base erected. Damage to the fly or personal injury could occur if all connecting pins are not properly installed.

17. Attach a hand line to the tip of the fly tip section. Remove the hitch pin which connects the fly tip section to the fly base section. Refer to Figure 4–11. Store the hitch pin back in the lug on the fly tip section once it is erected.
18. Swing the fly tip section around the fly base section until the fly tip lugs engage with the fly base lugs on the left side of the fly.

Operator's Manual

19. Remove the fly tip connecting pins from the storage holes on the rear of the fly tip section. Install them through the fly tip connecting lugs on both sides of the fly. Install the inside top right pin first. Swing the fly tip to the left to get the pin to drop in the hole. Install the inside bottom right pin. Swing the fly tip to the right to get the pin to drop in the hole. Install the top left pin and then the bottom left. (Install the pins with the head on top and the keeper on the bottom.) Install the pin keepers.



WARNING

All six fly tip connecting pins must be properly installed before operating the crane with the fly tip erected. Damage to the fly or personal injury could occur if all connecting pins are not properly installed.

20. Remove the wire rope guards from the fly base head, deflector and fly tip head sheaves. Refer to Figure 4–4. Reeve the winch wire rope on the boom deflector sheave then over the fly deflector, head and fly tip head sheaves. Install all wire rope guards.

CAUTION

All wire rope guards must be in proper position during operation.

21. Properly connect anti-two block system as follows:

- Disconnect the plug assembly from the jumper assembly on the main boom head and connect it to the connector assembly on the fly.

- Install the anti-two block weight on fly. Refer to Section 1 of this Operator's Manual.
- Properly install lockout clip on the main boom head anti-two block switch cable.

Note: When lockout clip is installed, the anti-two block switch is inactive.

When both main boom and fly are reeved for operation, the lockout clip must be removed and properly stored and an anti-two block weight must be suspended from each anti-two block switch.

- Properly set the Rated Capacity Limiter to the correct crane configuration. Refer to Section 1 of this Operator's Manual.
- Check the Crane Rating Manual for lifting capacities with the fly installed before continuing operations.



WARNING

The fly adds weight to the boom which must be considered in lifting capacities when the fly is erected. When making lifts from the main boom or auxiliary lifting sheave with the fly erected, refer to the Crane Rating Manual for the appropriate deductions from lifting capacities. Use the offset lattice fly only when the crane is level on fully or intermediate extended outriggers with all tires clear of the ground.

CAUTION

Do not erect the fly extension with the offset fly in the stored position on the boom. Damage may occur

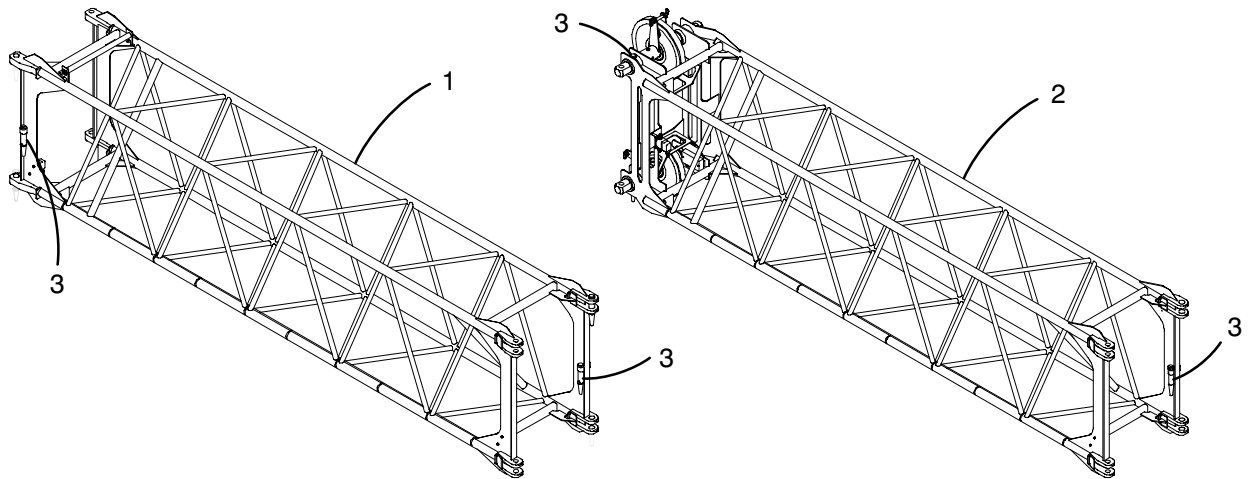

1. 16 Ft (4.9m) Fly Extension W/O Sheaves
2. 16 Ft (4.9m) Fly Extension With Lifting Sheaves
3. Fly Connecting Pin Storage Location

Figure 4-12
Fly Extensions

Fly Extensions

If the crane is equipped with a two piece offset lattice fly, one or two extensions are available to extend the overall fly length from 58 Ft (17.7m) to 74 ft (22.5m) or 90 ft (27.4m). These extensions pin between the boom head and fly base section. The fly base must be removed from the crane before adding or removing the fly extensions. Refer to Figure 4-12.



DANGER

To avoid serious injury, carefully read and understand all safety instructions outlined in this Operator's Manual. Failure to follow these instructions could result in serious personal injury or death.

CAUTION

Do not erect the fly extension(s) with the offset fly in the stored position on the boom. Major boom/fly damage may occur.

Operator's Manual



WARNING

Avoid injury to yourself. Fly can fall when pins are removed. Do not remove pins until fly is supported or stored properly. Refer to Operator's Manual for further information.

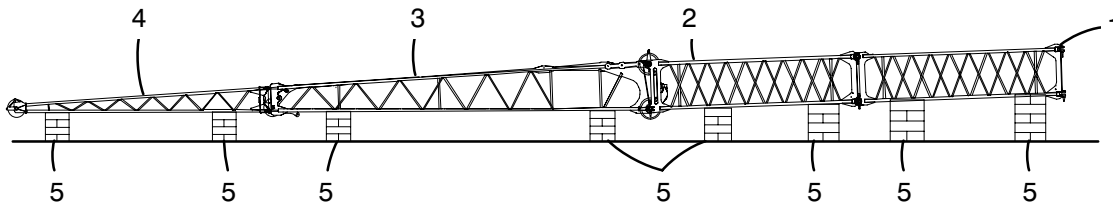

- | | |
|--|---|
| <ul style="list-style-type: none"> 1. Fly Extension W/O Sheaves 2. Fly Extension With Lifting Sheaves 3. Fly Base Section | <ul style="list-style-type: none"> 4. Fly Tip Section 5. Blocking |
|--|---|

Figure 4–13
Fly Assembly On Blocking

WARNING

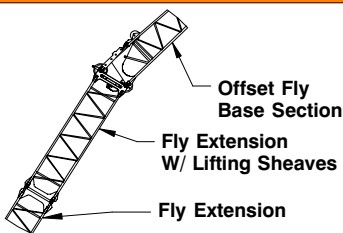

When using Extensions, the Fly Extension w/ Lifting Sheave must always be pinned to the Offset Fly Base Section. Do not pin the Fly Extension to the Offset Fly Base Section. Failure to comply with this procedure may result in personal injury and/or crane damage.



Figure 4–14
Fly Extension Label

16 Ft (4.9m) Fly Extension

The 16 ft (4.9m) fly extension must be pinned between the boom head and the 16 ft (4.9m) fly extension with sheaves to obtain a 90 ft (27.4m) fly. A deflector roller is mounted on top of the fly extension. The fly extension weighs approximately 650 lb (295kg). Refer to Figure 4–12 and Figure 4–15.

16 Ft (4.9m) Fly Extension With Lifting Sheave

The 16 ft (4.9m) fly extension with lifting sheave must be pinned between the boom head and the 35 ft (10.7m) offset fly to obtain a 74 ft (22.5m) fly or between the 16 ft (4.9m) extension without sheaves and the 35 ft (10.7m) offset fly to obtain 90 ft (27.4m) fly. The extension can also be used alone when pinned to the boom head. The fly extension with lifting sheave weighs approximately 950 lb (431kg). Refer to Figure 4–12 and Figure 4–15.

Operator's Manual

Installing/Adding Fly Extension(s)

The fly base section must be removed from the crane before installing/adding or removing fly extension(s). Remove the fly base and place adequate blocking under each end of the section(s) before removing any connecting pin. Refer to the instructions in this Section of this Operator's Manual for proper removal and installation procedures.

Note: Before installing 16 ft (4.9m) fly extension(s), change the boom mode to EM1.

CAUTION

Do not erect the fly extension(s) with the offset fly in the stored position on the boom. Major boom/fly damage may occur.

FLY ARRANGEMENTS

| Fly | Components Required | | | | Refer to Fig 4-15 |
|-----------------|---------------------|-------------|----------------------------|------------------------|-------------------|
| | 35' Fly Base | 23' Fly Tip | 16' Fly Ext W/ Lift Sheave | 16' Fly Ext W/O Sheave | |
| 35' | ● | | | | A |
| 58' | ● | ● | | | B |
| 74' | ● | ● | ● | | C |
| 90' | ● | ● | ● | ● | D |
| 16' w/ Lift Shv | | | ● | | E |



WARNING

Properly remove the fly sections from the crane before attempting to modify the length. Do not place any part of your body under the fly when it is being assembled or disassembled. Removing any connecting pins from the fly before it is properly supported may allow the fly to jackknife and injure someone. Adequately support each end of each section before attempting to lengthen or shorten the fly.

1. Extend the boom to a length that is greater than the length of extension(s) to be installed/added.
2. Set the fly on secure blocking. Remove the fly connecting pins from the boom head.

3. Retract the boom away from fly.
4. Position blocking and assemble the fly extension(s) to the fly base section or boom head. Install all the connecting pins. Install the pins with the head on top and the keeper on the bottom. Install the pin keepers. When installing the fly base section to the 16 ft (4.9m) fly extension with lifting sheaves, remove fly extension connecting pins from the top and bottom extension head machinery cross shafts and install them in the fly base lugs on the left side of the fly extension. When not using the fly base section, return the left side connecting pins to the 16 ft (4.9m) fly extension with lifting sheaves top and bottom head machinery cross shafts to prevent shafts from turning.
5. Extend the boom into the extension lugs. Install all four connecting pins through the front fly base lugs. Install the pins with the head on top and the keeper on the bottom. Install the pin keepers.

Removing Fly Extension(s)



WARNING

Properly remove the fly sections and extensions from the crane before attempting to modify the length. Do not place any part of your body under the fly when it is being assembled or disassembled. Removing any connecting pins from the fly before it is properly supported may allow the fly to jackknife and injure someone. Adequately support each end of each section before attempting to lengthen or shorten the fly.

1. Extend the boom and lower the fly and extension(s) onto secure blocking. Remove the extension(s) connecting pins and disassemble the fly sections.
2. Re-pin the desired fly sections. Install the pins with the head on top and the keeper on the bottom. Install the pin keepers.
3. Slowly raise or lower the boom to engage the fly lugs.
4. Install all connecting pins through the boom head machinery cross shafts. Install the pins with the head on top and the keeper on the bottom. Install the pin keepers.

Note: If removing all fly extensions and fly sections, install the top and bottom left side fly extension/fly base connecting pins in the storage position on the boom head machinery cross shafts to prevent shafts from turning.

Operator's Manual

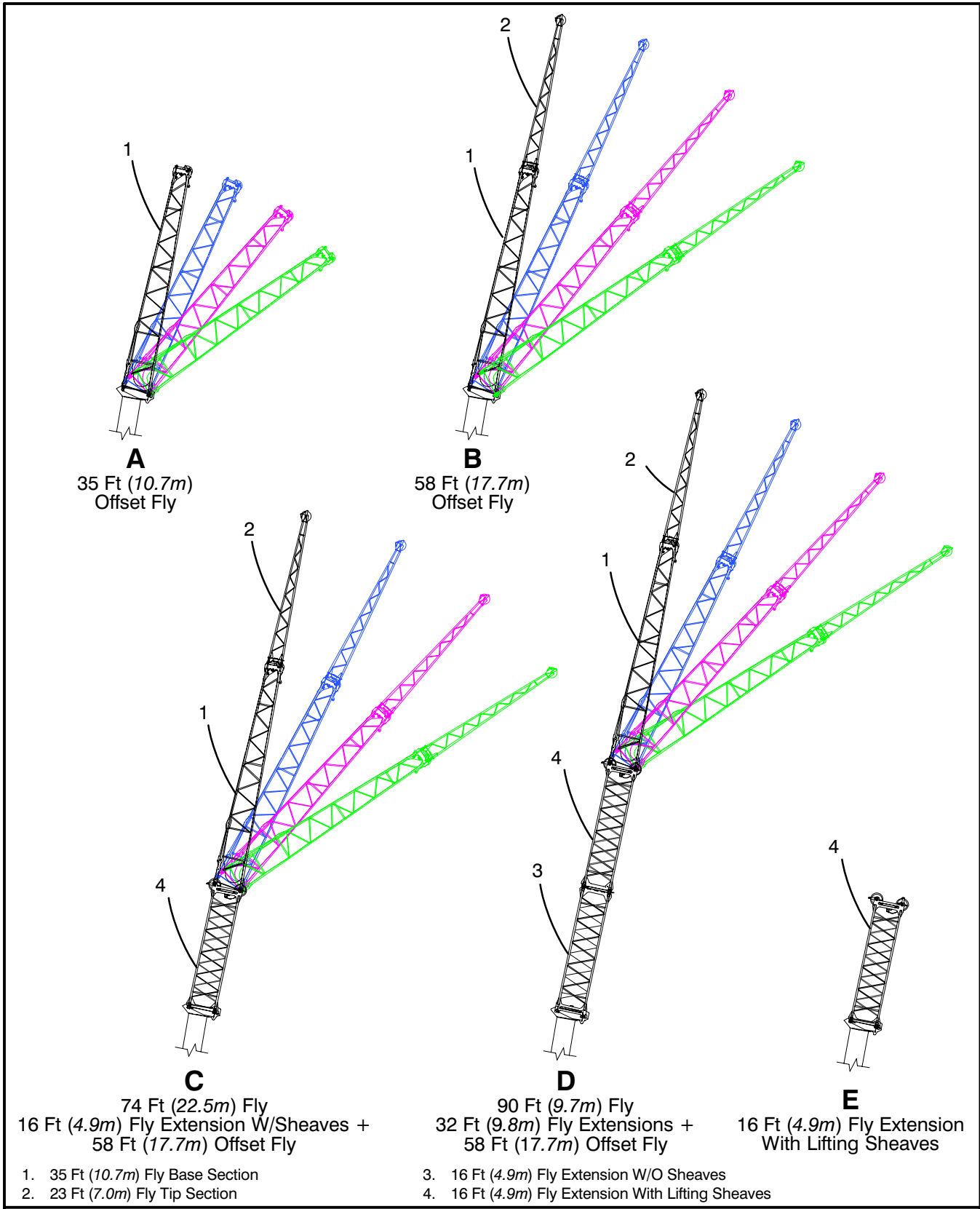

Figure 4-15
Fly Arrangements

Table Of Contents

| | |
|---|-------------|
| Crane Rating Manual And Serial Number | 5-1 |
| Wire Rope Capacity Chart | 5-1 |
| Wire Rope Specifications | 5-1 |
| Wire Rope Diameter | 5-1 |
| Wire Rope Capacity | 5-2 |
| Wire Rope Inspection And Replacement Recommendations | 5-3 |
| Wire Rope Inspection | 5-4 |
| Wire Rope Replacement | 5-4 |
| Wire Rope Installation | 5-4 |
| Winch Roller Adjustment | 5-5 |
| Uncoiling Wire Rope | 5-6 |
| Anchoring Wire Rope To Drum | 5-6 |
| Winding Wire Rope On Drum | 5-7 |
| Wire Rope Reeving | 5-7 |
| Sockets And Wedges | 5-8 |
| Socket And Wedge – Without Extended Wedge | 5-9 |
| Socket And Wedge Assembly – With Extended Wedge | 5-10 |
| Wire Rope Break-In | 5-11 |
| Single Part Line Hoisting | 5-12 |
| Hook Ball Usage With Rotation Resistant Wire Rope | 5-12 |
| Non-Swivel Usage | 5-12 |
| Swivel Usage | 5-12 |
| Wire Rope Inspection | 5-12 |
| Wire Rope Sockets With Clips | 5-13 |
| Wire Rope Clip Installation | 5-13 |
| Cutting Wire Rope | 5-14 |
| Wire Rope Reeving Diagrams | 5-15 |
| Event Data Recording | 5-17 |
| Event Data Recorder | 5-17 |
| Data And Recording Privacy | 5-17 |
| Crane Specifications | 5-18 |
| General Dimensions | 5-18 |

Operator's Manual

| | |
|--|------|
| Boom, Attachments, and Upper Structure | 5-19 |
| Boom | 5-19 |
| Boom | 5-19 |
| Boom Wear Pads | 5-19 |
| Boom Head | 5-19 |
| Boom Elevation | 5-19 |
| Auxiliary Lifting Sheave – Optional | 5-19 |
| Hook Blocks and Balls – Optional | 5-19 |
| Fly – Optional | 5-19 |
| Fly Extensions – Optional | 5-19 |
| Operator's Cab and Controls | 5-20 |
| Swing | 5-21 |
| Electrical | 5-21 |
| Load Hoist System | 5-22 |
| Load Hoist Performance | 5-22 |
| 2M Main and Optional Auxiliary Winches | 5-22 |
| Hydraulic System | 5-22 |
| Counterweight | 5-22 |
| Carrier | 5-22 |
| General | 5-22 |
| Outriggers | 5-23 |
| Steering and Axles | 5-23 |
| Suspension | 5-23 |
| Tires and Wheels | 5-23 |
| Brakes | 5-23 |
| Electrical | 5-23 |
| Engine | 5-23 |
| Transmission | 5-23 |
| Carrier Speeds and Gradeability | 5-24 |
| Fuel Tank | 5-24 |
| Hydraulic System | 5-24 |
| Pump Drive | 5-24 |
| Axle Loads | 5-25 |

Operator's Manual

Crane Rating Manual And Serial Number

The Crane Rating Manual is in the lower right interior of the operator's cab. The Crane Rating Manual has the crane serial number on it. The serial number is also stamped on the top of the outrigger box on the right side of the carrier and on the top right front of the upper frame near the boom hoist cylinder lug. The serial number must be used with any correspondence with a Link-Belt Distributor or the Factory concerning parts or warranty. The Crane Rating Manual also lists the maximum allowable lifting capacities for the crane. The Crane Rating Manual should be checked for the proper lifting capacities before making any lifts.

If the Crane Rating Manual becomes lost, damaged, or unreadable, it must be replaced before operating the crane. Information contained in the Crane Rating Manual is important and failure to follow the information it contains could result in an accident. A replacement Crane Rating Manual can be ordered through a Link-Belt Distributor.

CAUTION

The Crane Rating Manual in the crane is the only authorized listing of lifting capacities for the crane. It supercedes any other printed literature which lists lifting capacities. It alone is to be used for determining crane capacities.

Wire Rope Capacity Chart

The Wire Rope Capacity chart gives the maximum lifting capacities based on wire rope capacity. A typical example is shown in Figure 5–1. It is in the Crane Rating Manual. It lists the maximum load that should be lifted with different sizes and types of wire rope. The weights shown are based on wire rope capacity alone. Exceeding these load weights may result in wire rope damage or failure.

Before making a lift, compare the weight being lifted (remember to add the weight of the hook block, hook ball, slings, and riggings to the actual load weight) with the Wire Rope Capacity Chart and/or the Winch Performance Chart in the Crane Rating Manual. Check the chart for the number of parts of line required to make

the lift. Use at least that number of parts of line to make the lift. When making a lift with more parts of line that is needed to make the lift, remember to add weight for each one (1) foot (0.3m) of extra wire rope required to reeve the extra parts of line, to the actual load weight. The extra parts of line act as additional load weight. Refer to Wire Rope Capacity chart in the Crane Rating Manual for actual weight per foot (0.3m) for the wire rope used.



WARNING

Do not exceed the capacities listed for wire rope capacity or crane capacity, whichever is less, when making a lift. Serious personal injury or crane damage may result.

Wire Rope Specifications

The specifications for the wire rope used on this crane are on the Wire Rope Capacity chart in the Crane Rating Manual. Refer to Figure 5–1 for a typical example. Always refer to the Wire Rope Capacity Chart in the Crane Rating Manual when ordering replacement wire rope.

Wire Rope Diameter

In standard practice, the nominal diameter of wire rope is the minimum acceptable diameter. It is always made larger, not smaller, than the nominal diameter according to the allowable tolerances shown in the following chart:

| Nominal Wire Rope Diameter | Allowable Limits | |
|---------------------------------------|------------------|-----|
| Thru 1/8" (3.2mm) | –0 | +8% |
| Over 1/8" (3.2mm) thru 3/16" (4.8mm) | –0 | +7% |
| Over 3/16" (4.8mm) thru 5/16" (8.0mm) | –0 | +6% |
| Over 5/16" (8.0mm) and larger | –0 | +5% |

Wear and stress tend to reduce the diameter. It should be measured periodically and replaced if the size is below the nominal size of the wire rope being used as shown in the chart on page 5–4. It should always be measured across the largest diameter that will fit inside a true circle. Refer to Figure 5–2.

Operator's Manual

| Wire Rope Capacity | | | | | |
|--|---------|---------|---------|-------------|---|
| Maximum Lifting Capacities Based On Wire Rope Strength | | | | | |
| Parts of Line | 3/4" | 3/4" | 3/4" | Wire Rope | Notes |
| | Type GC | Type RB | Type ZB | Third Layer | |
| 1 | 22,400 | 12,920 | 15,600 | 14,362 | 1 Capacities shown are in pounds and working loads must not exceed the ratings on the capacity charts in the Crane Rating Manual. 2 Capacity deducts for auxiliary lifting devices do not apply for wire rope strength capacities. 3 Capacities over 129,200 lb may require special reeving and/or higher strength wire rope. 4 Study Operator's Manual for wire rope inspection procedures, single part of line applications, and reeving diagrams. 5 Due to the high single line pull allowable when using type "GC" wire rope, it is recommended that the winch available line pull be used to calculate the required parts of line to make the lift. Example Using the 1st layer line pull to lift from: $(\text{Load}(\text{lb})/76,880 = \text{Parts of line})$ Using the 4th layer line pull to lift from: $(\text{Load}(\text{lb})/13,365 = \text{Parts of line})$ |
| 2 | 44,800 | 25,840 | 31,200 | 28,724 | |
| 3 | 67,200 | 38,760 | 46,800 | 43,086 | |
| 4 | 89,600 | 51,680 | 62,400 | 57,448 | |
| 5 | 112,000 | 64,600 | 78,000 | 71,810 | |
| 6 | 134,400 | 77,520 | 93,600 | 86,172 | |
| 7 | 156,800 | 90,440 | 109,200 | 100,534 | |
| 8 | 179,200 | 103,360 | 124,800 | 114,896 | |
| 9 | 201,600 | 116,280 | 140,400 | 129,258 | |
| 10 | 224,000 | 129,200 | 156,000 | 143,620 | |
| 11 | — | 142,120 | 171,600 | 157,982 | |
| 12 | — | 155,040 | 187,200 | 172,344 | |
| Rope Weight—Pounds Per Foot | 1.1 | 1.2 | 1.3 | N/A | |

| LBCE Type | Description |
|-----------|--|
| GC | 4 Strand, Low Torque, Right Regular Lay |
| RB | 18 X 19 Rotation Resistant – Compacted Strand – High Strength Preformed, Right Regular Lay |
| ZB | 34 X 7 Non-Rotating – Extra Improved Plow Steel – Right Regular or Right Lang Lay |

Note: The Wire Rope Capacity chart depicted above is shown as an example only. Use the official Wire Rope Capacity chart in the Crane Rating Manual. Use it to determine the correct parts of line required for the given wire rope type and diameter.

Note: Always refer to the crane's Parts Manual when ordering wire rope.

Figure 5–1
Typical Wire Rope Capacity Chart (Example Only)

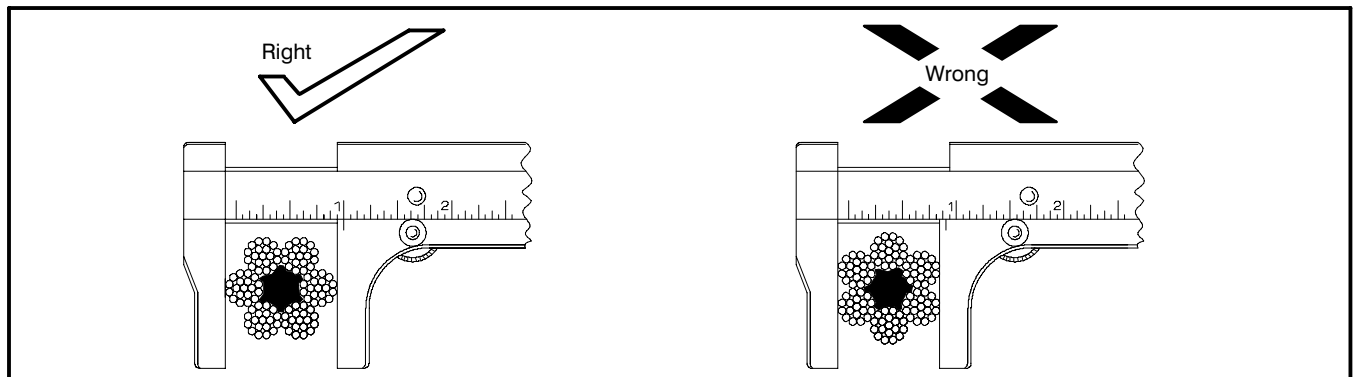

Figure 5–2
Measuring Wire Rope Diameter

| WIRE ROPE INSPECTION REPORT | | | | | | | | | | | |
|------------------------------------|-------------------|---------------|-----------------------------|----------------------------|-----------------|-----------------------------|-------------------|-------------|------------------|----------------|----------------------|
| Crane S/N _____ | | | Owned By _____ | | | Crane Location _____ | | | | | |
| Date of Inspection _____ | | | Wire Rope Application _____ | | | Wire Rope Description _____ | | | | | |
| Manufacturer's I.D. No. _____ | | | | Applicable Standards _____ | | | | | | | |
| Criteria for Removal | | | | 1/3 of Outside Wire Dia. | 1 | | | | | | |
| Location on Wire Rope | Measured Diameter | Broken Wires | | Excessive wear | End Attachments | | | Rope Damage | Sheave Condition | Drum Condition | Rope Lay Measurement |
| | | In 1 Rope Lay | In 1 Strand of 1 Lay | | Broken Wires | Corrosion of Rope | Fitting Condition | | | | |
| | | | | | | | | | | | |
| | | | | | | | | | | | |
| | | | | | | | | | | | |
| | | | | | | | | | | | |
| | | | | | | | | | | | |
| | | | | | | | | | | | |
| | | | | | | | | | | | |
| | | | | | | | | | | | |
| Signature: _____ | | | | | | | | | | | |

Figure 5–3
Typical Wire Rope Inspection Report

Wire Rope Inspection And Replacement Recommendations

The three basic reasons for deterioration of wire rope are abrasion, corrosion, and damage caused by fatigue bending, crushing, kinking, and forces or abuse acting against the wire rope during normal usage.

When wire rope is replaced, use the type specified on the Wire Rope Capacity Chart in the Crane Rating Manual. Cranes are designed to use a specific type and size of wire rope. Using wire ropes other than those recommended, may result in short life or even failure of the wire rope.

According to ASME standards, all wire ropes in active service **MUST BE** visually inspected daily. A qualified, trained person should be appointed to conduct the inspection. Also on a monthly basis, that person is required to inspect all wire ropes and keep a dated, written record noting any damage and recording when wire ropes are replaced.

These inspections should be done to determine the degree of deterioration of the wire rope at any given section (refer to the following on wire rope replacement). This will determine the suitability of the wire rope for continued service. A sample inspection report is shown in Figure 5–3. It can be reproduced and used if desired.

Operator's Manual

Wire Rope Inspection

Any of the following are reasons to question wire rope safety:

1. More than one broken wire in any one strand should be cause for caution. Breaks that occur on the worn crowns of the outside wires usually indicate normal deterioration. Breaks that occur in the valleys between strands can indicate an abnormal condition, possibly fatigue and breakage of other wires that are not readily visible. One or more valley breaks should be cause for replacement.
2. Wire breaks generally occur in those portions of wire rope which pass over sheaves, wind onto drums, or receive mechanical abuse. Breaks that occur near attached fittings are apt to result from fatiguing stresses concentrated in these localized sections. Breaks of the latter type should be cause for replacement of the wire rope or renewal of the attachment to eliminate the locally fatigued area. When running wire ropes over nylon sheaves, inspect the wire rope where it travels over the sheaves. Inspect for a loss of diameter and then bend the wire rope to inspect the internal wires for breaks and wear.
3. Heavy wear, or broken wires, may occur in sections under equalizer sheaves or other sheaves where wire rope travel is limited, or in contact with saddles. Particular care should be taken to inspect wire rope at these points. If wire rope wear is detected at these locations, these wear points can be shifted by removing the wire rope from the drum and cutting a 20 ft (6.1m) section off at the drum end. This may assist in extending the wire rope life.
4. Wire rope stretch is generally greatest during initial stages of operation when the strands are becoming adjusted and seated. This is accompanied by some reduction in wire rope diameter.
5. Time for wire rope replacement is indicated by the extent of abrasion, scrubbing, and peening on the outside wires, broken wires, evidence of pitting or severe corrosion, kink damage, or other mechanical abuse resulting in distortion of the wire rope structure.
6. Sheaves, guards, guides, drums, flanges, and other surfaces contacted by wire rope during operation should be examined at the time of inspections. Any condition harmful to the wire rope in use at the time should be corrected. The same equipment and particularly sheave and drum grooves should be inspected and placed in proper condition before a new wire rope is installed.

Wire Rope Replacement

Any of the following are reasons for wire rope replacement:

1. In running wire ropes, six randomly distributed broken wires in one wire rope lay or three broken wires in one strand in one wire rope lay.

For rotation resistant wire ropes, two randomly distributed broken wires in six wire rope diameters, or four randomly distributed broken wires in thirty wire rope diameters.
2. In pendants or standing wire ropes, evidence of more than two broken wires in one lay in sections beyond end connections or more than one broken wire in one wire rope lay at end connection.
3. One outer wire broken at the contact point with the core of the wire rope which has worked its way out of the wire rope structure and protrudes or loops out from the wire rope structure.
4. Abrasion, scrubbing, or peening causing loss of more than 1/3 the original diameter of individual wires.
5. Evidence of wire rope deterioration from corrosion.
6. Kinking, crushing, "bird caging", or other damage resulting in distortion of the wire rope structure.
7. Evidence of any heat damage.
8. Marked reduction in diameter indicates deterioration of the core resulting in lack of proper support for the load carrying strands. Excessive wire rope stretch or elongation may also be an indication of internal deterioration. Reduction from nominal diameter or more than:

| Reduction of | Nominal Wire Rope Diameters |
|---------------|-----------------------------------|
| 1/64" (.4mm) | up to and including 5/16" (8mm) |
| 1/32" (.79mm) | over 5/16" (9.5mm) to 1/2" (13mm) |
| 3/64" (1.2mm) | over 1/2" (13 mm) to 3/4" (19mm) |
| 1/16" (1.6mm) | over 3/4" (19mm) to 1-1/8" (29mm) |
| 3/32" (2.4mm) | over 1-1/8" (29mm) |

9. Noticeable rusting or development of broken wires in the area of connections.

Wire Rope Installation

When installing wire rope, the primary concern is getting the wire rope onto the drum without trapping any twist that may have been induced during handling. Use the following procedure to install the wire rope on the crane.

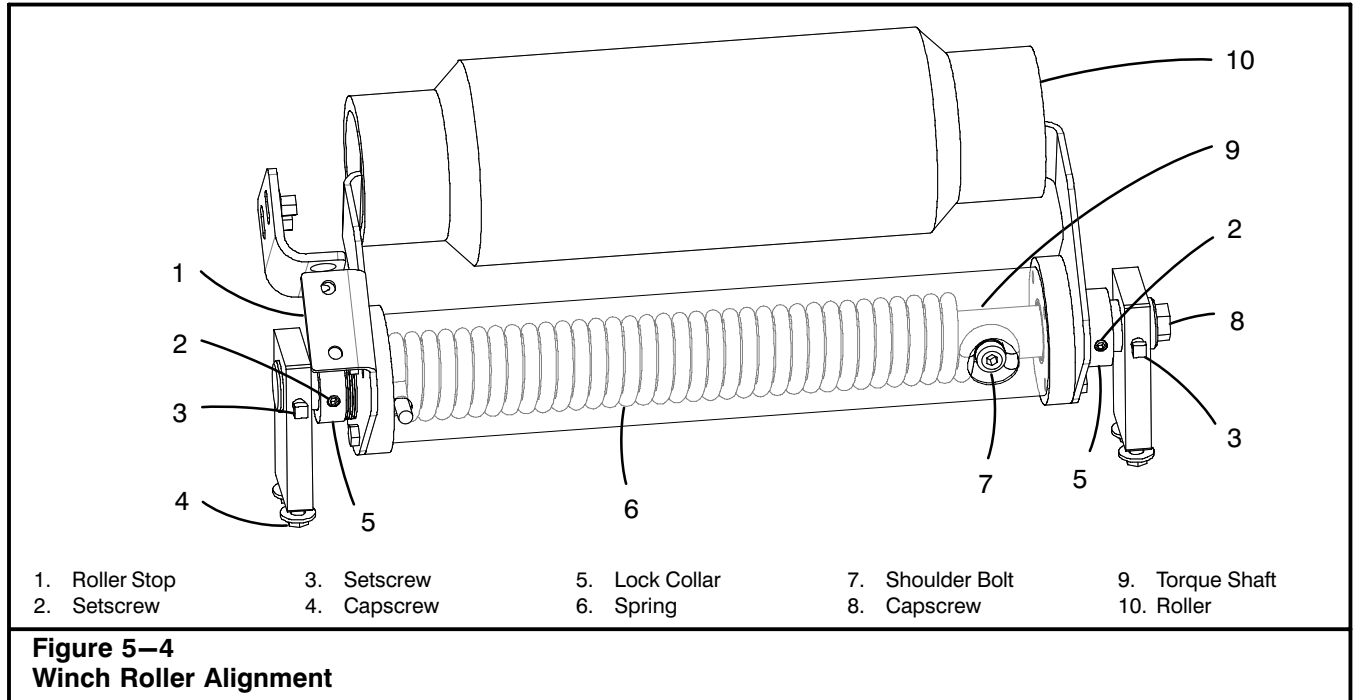

Winch Roller Adjustment

Before installing wire rope on the drum, adjust the drum roller. Refer to Figure 5—4. If the roller is not aligned to the drum, it may cause excessive wear on the wire rope, winch roller, or impede spooling of the wire rope on the drum. To adjust the roller, loosen the capscrews (4) and adjust roller assembly as required to align the roller parallel to the drum. Roller should lay flat across each full layer of wire rope on the drum and be centered between the drum flanges. Center the roller between the drum flanges by loosening the setscrews (2) in the lock collars (5), centering the roller (10), and tightening the setscrews. After roller is aligned and centered, preload the spring using the following procedure.



WARNING

Do not attempt to service winch roller before properly relieving torsion spring tension. If proper directions are not followed, the torsion spring could rapidly and forcefully uncoil. This may result in serious personal injury and component damage. Always release tension on torsion spring before attempting any winch roller repair.

1. Properly release torsion spring (6) tension as follows.

This procedure is greatly simplified by using two service technicians. One to hold the breaker bar/wrench, the other to loosen and tighten setscrews.

- a. Ensure capscrew (8) is tightened securely in torque shaft (9).
 - b. Using a breaker bar or long handle wrench, hold tension on torsion spring (6) while loosening the setscrews (3) on both ends of torque shaft (9).
 - c. Allow torque shaft (9) to rotate counterclockwise, as far as possible while maintaining control of the torque shaft (9), then securely tighten setscrews (3).
 - d. Reposition breaker bar or wrench on capscrew (8).
 - e. Repeat Steps b—d until tension is fully relieved from torsion spring (6).
2. Turn the capscrew (8), which will rotate the torque shaft (9), until the bolt (7) through the torque shaft contacts the spring (6).

CAUTION

Do not overtighten the spring. Damage to the wire rope may occur.

3. With the roller stop (1) resting against the drum flange or with the roller resting evenly on the first layer of wire rope on the drum, use 105 ft lb (124Nm) of torque to rotate the spring not to exceed one revolution (360°).
4. Tighten setscrews (3). The roller should roll freely when the drum rotates.

Operator's Manual

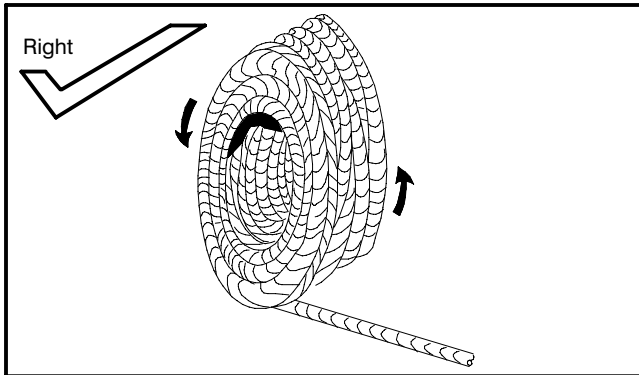

Figure 5-5
Uncoiling Wire Rope

Uncoiling Wire Rope

1. To avoid twists, unreel the entire wire rope on the ground in line with the boom deflector sheave and drum. Set the reel up horizontally so it can rotate as the wire rope is reeled off. Refer to Figure 5-5. Reel the wire rope off slowly, so the reel won't tend to "throw" the wire rope off. If the new wire rope cannot be laid out on the ground, further steps are necessary:
 - a. Mount the reel on a shaft through flange holes and on jack stands, making sure the reel is set to be unreeled over the top. Do not allow the reel to "free-wheel". Brake the reel by applying pressure to a flange. Do not apply braking pressure to the wire rope on the reel or pass wire rope between blocks of wood or other material.
2. Reeve the wire rope over the boom deflector sheave and anchor it to the drum.

Note: When replacing wire rope, the sheaves and grooves in drums should be checked for wear or damage and replaced if necessary. Damaged, worn or undersized sheaves will damage the wire rope. On older equipment, remember that new wire rope is usually larger in diameter than the worn wire rope it replaces. The sheave grooves may be worn to the smaller diameter of the old wire rope.

Note: A new wire rope should be broken in by running it slowly through its working cycle for a short period under a light load. Refer to "Wear Rope Break-In" in this Section of this Operator's Manual.

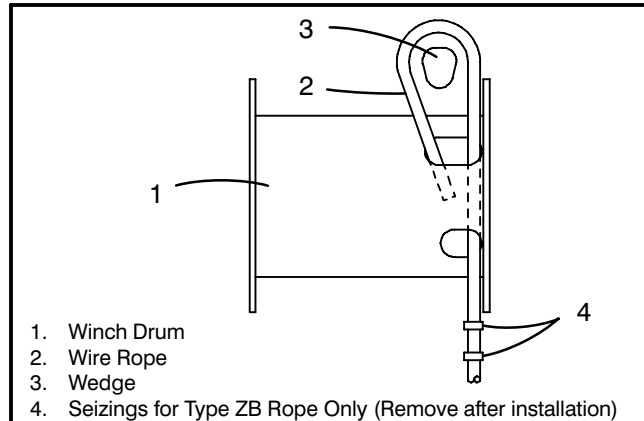

Figure 5-6
Anchoring Wire Rope To Drum

Anchoring Wire Rope To Drum

CAUTION

The ends of type ZB wire rope must be fuse welded. Failure to do so may cause the core to slip and/or the strands to loosen causing major wire rope damage.

If crane is equipped with type ZB wire rope, attach two seizings (hose clamps are an effective and efficient alternative if traditional seizings are not available) about 24 in (609.6mm) from the end with a 3 in (76.2mm) space between them. Refer to Figure 5-6. The seizings will prevent any looseness of the outer strands from traveling up the wire rope during installation. Insert the free end of the wire rope into the small opening of the anchor pocket. Loop the wire rope and push the free end about 3/4 of the way back through the pocket. Install the wedge, then pull the slack out of the wire rope. If using type ZB wire rope, remove the seizings after the wire rope is secured in the drum. Keep tension on the wire rope to prevent the wire rope from becoming slack and forming loops or kinks and also to allow uniform winding on the drum. It is important that original wire rope lay is maintained at all times.

Winding Wire Rope On Drum

Proper winding of the first layer of wire rope on a multiple wrap drum is important. If the first layer is properly wound, succeeding layers will be easier to control.

This is especially important on ungrooved drums. When starting new wire rope on such drums, drive each wrap of the first layer lightly with a wooden mallet so each wrap barely contacts the preceding one. Keep tension on the wire rope to prevent the wire rope from becoming slack and forming loops or kinks and also to allow uniform winding on the drum. It is important that original wire rope lay is maintained at all times.

It's important to apply a tensioning load while spooling the wire rope on the drum. (If not, the lower layers may be loose enough that the upper layers become wedged into the lower layers under load, which can seriously damage the wire rope.) The tensioning load should range from 1 to 2% of the wire rope's nominal capacity.

Wire Rope Reeving

Hook blocks should be reeved correctly so they hang straight and do not cause excessive wear on the wire rope and sheaves. Refer to Figure 5-7.

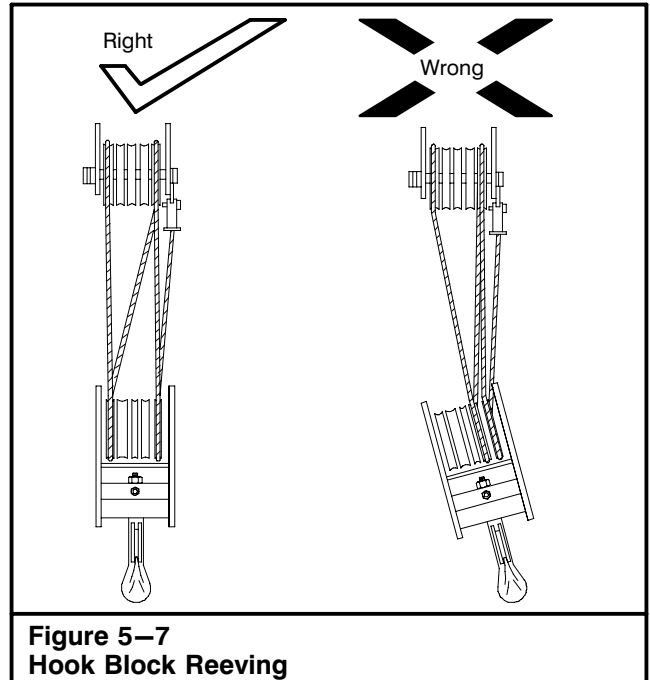

Figure 5-7
Hook Block Reeving

The fly section may be reeved with two parts of line for better line control. Figure 5-18 and Figure 5-19 gives the proper reeving for various parts of line. The reeving patterns illustrated must be used at all times. To determine how many parts of line to use for a particular lift, check the Wire Rope Capacity chart and the Winch Performance chart in the Crane Rating Manual.

Note: Wire rope guards must always be used during operations. They must be pinned in place to prevent wire rope from jumping off the sheaves.



WARNING

To avoid personal injury, do not climb, stand, or walk on the boom or fly. Use a ladder or similar device to reach necessary areas when reeving the crane.

Only if certain criteria are met, a swivel hook ball may be used with rotation resistant wire rope. Refer to "Hook Ball Usage With Rotation Resistant Wire Rope" in this Operator's Manual.

The crane can use multiple parts of line when reeving the main winch, depending on the lift being made and the number of sheaves available. When reeving the winch, odd parts of line dead end at the hook block or hook ball and even parts dead end at the boom head. The auxiliary lifting sheave may be reeved with either one or two parts of line.

Note: Do not use a swivel at the dead end of a multi-part reeving.

Operator's Manual

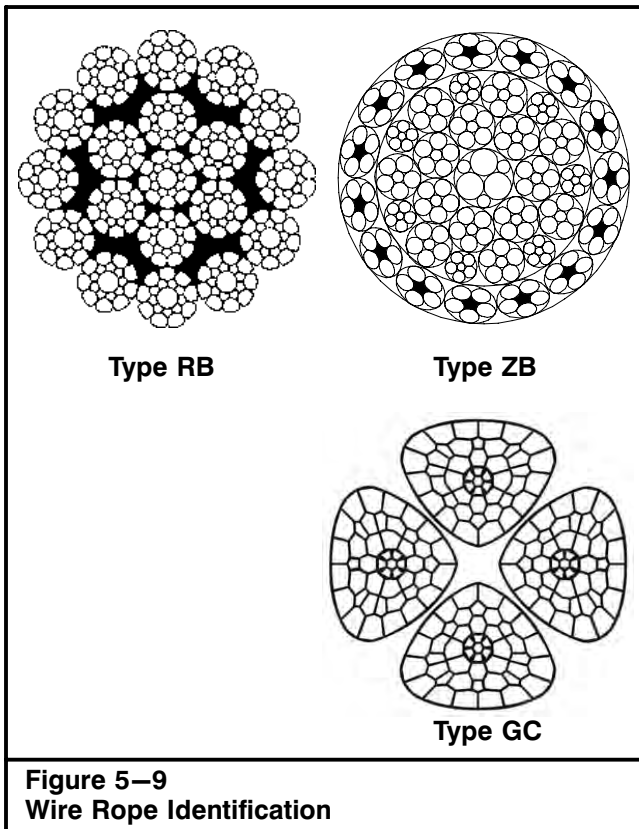
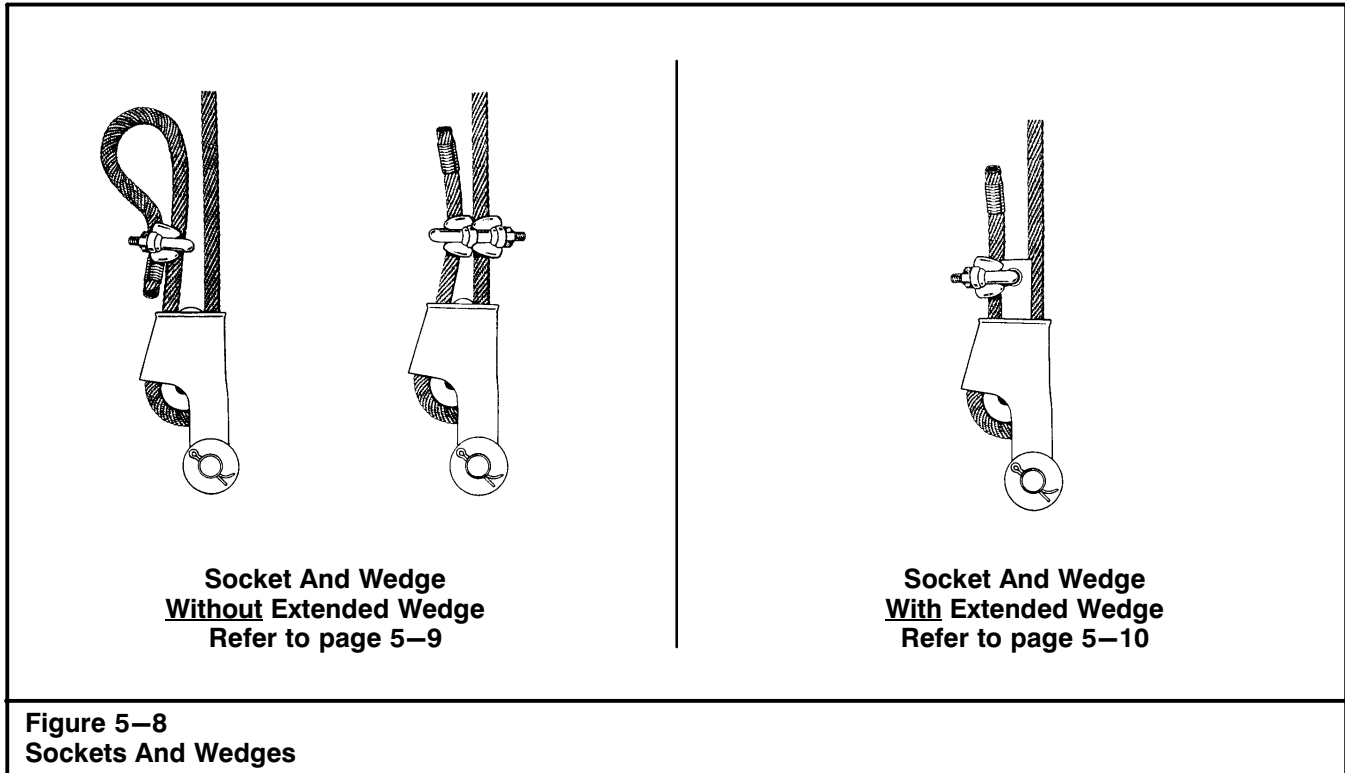

Sockets And Wedges

This crane may be equipped with either of two styles of sockets and wedges. One style socket uses a “terminator” extended wedge and the other does not. The wedges for each style are installed differently. Refer to Figure 5-8 to determine which style your crane has and where to find the appropriate information for use and installation.



WARNING

Do not interchange sockets and wedges. Loads may slip or fall if socket and wedge are not properly matched. Use a “terminator” wedge with a socket for a “terminator” wedge and a non-“terminator” wedge with a non-“terminator” socket.

Socket And Wedge – Without Extended Wedge

CAUTION

Use the proper size wedge with a wire rope socket or lagging. The use of an off-size wedge in a socket or lagging is dangerous as it may not hold. Wedges and sockets shipped from the factory are stamped with size and type identification. A lagging or socket may be stamped for two or more sizes of wire rope and a wedge for one or two. The size on the lagging, socket, and wedge must correspond with the size of wire rope being used.

The correct and incorrect methods of attaching a socket and wedge to wire rope are shown in Figure 5–10. The dead end of the wire rope must always be on the sloped portion of the socket. The load line must be in a straight line pull with the eye of the socket. If the wire rope is installed wrong as shown in Figure 5–10, a permanent set will develop at the point where the wire rope enters the socket. This permanent set will weaken the wire rope and accelerate wear at this point.

Before installing type ZB wire rope into a socket or wedge attach two seizings (hose clamps are an effective and efficient alternative if traditional seizings are not available) approximately 3–4 ft (0.9–1.2 m) from the end with a 3 in (76.2 mm) space between them. Refer to Figure 5–10.

The dead end must also be seized and a minimum tail length of 20 wire rope diameters [15" (.38m) for 3/4" (19mm) wire rope] for rotation resistant wire ropes and 6 wire rope diameters minimum for 6 to 8 strand wire rope is required. Refer to Figure 5–10. The seizings will help prevent core slippage and any looseness of the outer strands from traveling up the wire rope during installation while still allowing the wire rope strands to be free to adjust. If using type ZB wire rope, remove seizings from the live end after wire rope is securely installed into the socket.

Note: Refer to Figure 5–9 to identify which type of wire rope is installed on the crane.

CAUTION

The ends of type ZB wire rope must be fuse welded and the tail length of the dead end must be a minimum of 20 wire rope diameters [15" (.38m) for 3/4" (19mm) wire rope]. Failure to do so may cause the core to slip and/or the strands to loosen causing major wire rope damage.

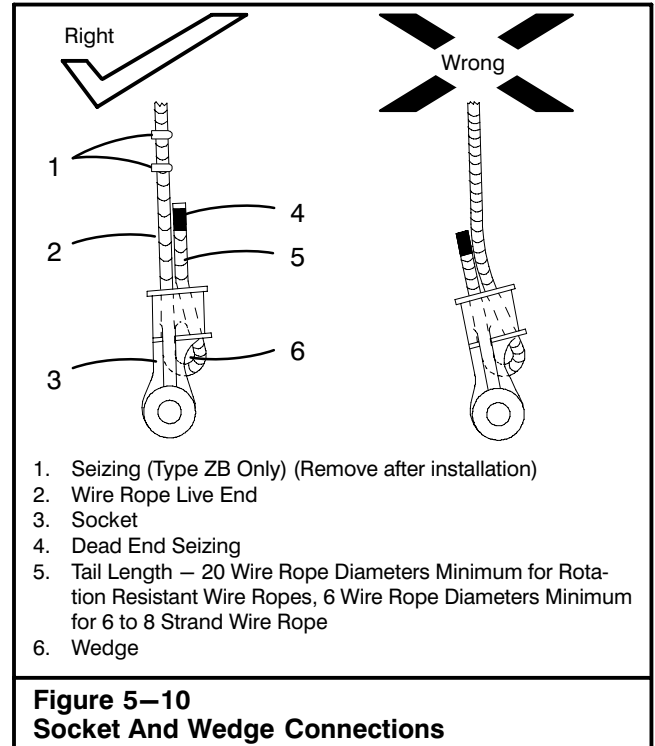
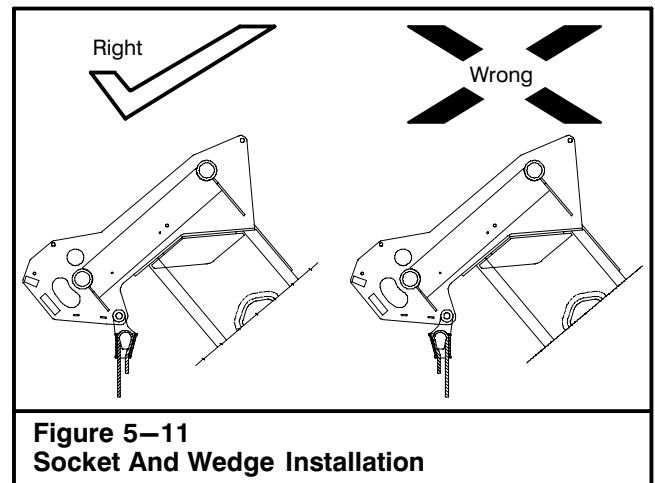

Figure 5–10
Socket And Wedge Connections



When anchoring the socket to the boom head, ensure the flat face is facing out as shown in Figure 5–11. If socket is not installed correctly structural damage to the boom head may occur.

It is recommended that the wire rope socket and wedge connection be reestablished on an annual basis. This can be accomplished by cutting the wire rope 6 in (0.15m) above the socket and wedge connection. See "Cutting Wire Rope" in this Section of this Operator's Manual. Install the socket and wedge connection as shown in Figure 5–10.

Operator's Manual

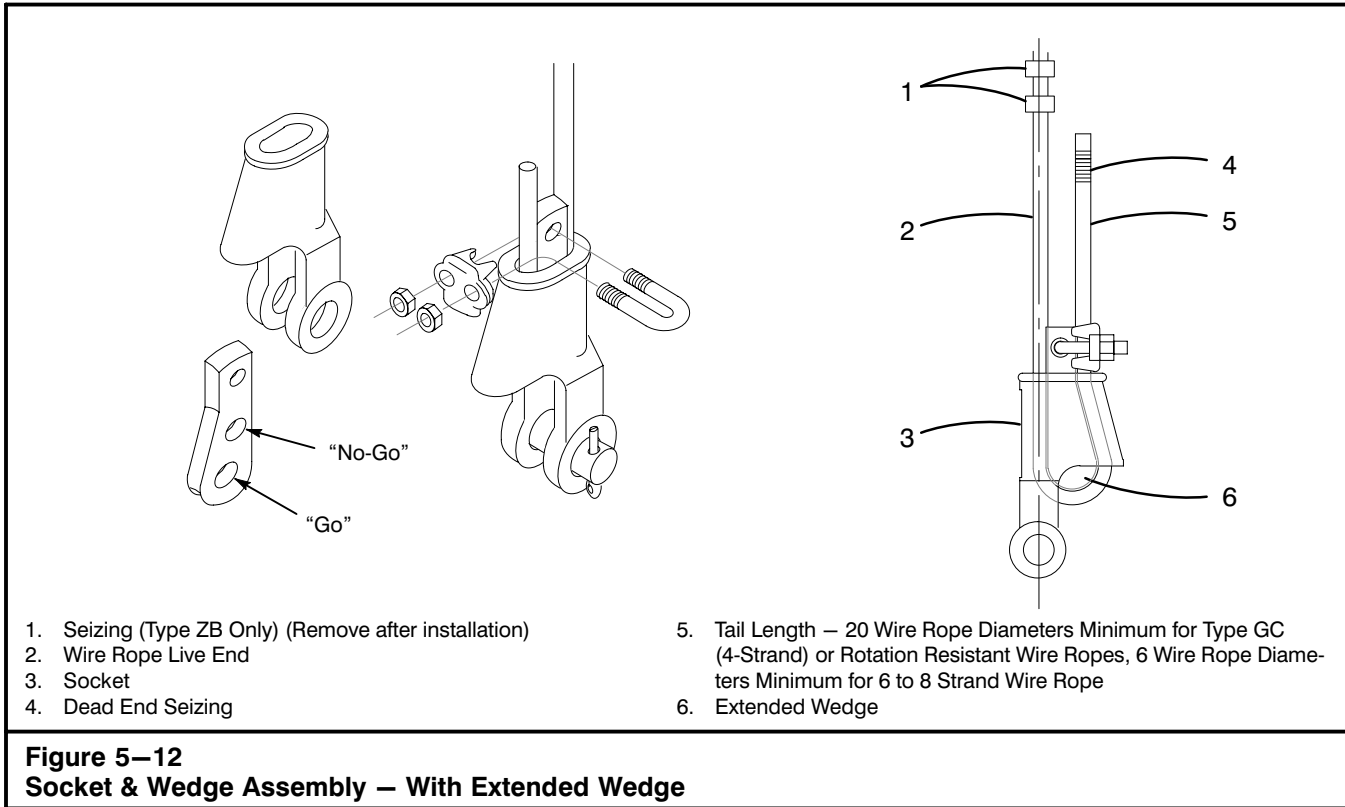

Socket And Wedge Assembly – With Extended Wedge



WARNING

Use the proper size wedge with a wire rope socket or drum. The use of an incorrect size, type, or brand of wedge in a socket or drum is dangerous as it may not hold. Wedges and sockets shipped from the factory are stamped with size and type identification. A drum or socket may be stamped for two or more sizes of wire rope and a wedge for one or two. The size on the drum, socket, and wedge must correspond with the size of wire rope being used.



WARNING

Do not interchange sockets and wedges. Loads may slip or fall if socket and wedge are not properly matched. Use a “terminator” wedge with a socket for a “terminator” wedge and a non-“terminator” wedge with a non-“terminator” socket.

The correct and incorrect methods of attaching a socket and wedge to wire rope are shown in Figure 5–12 and Figure 5–13. The dead end of the wire rope must always be on the sloped portion of the socket. The load line must be in a straight line pull with the eye of the socket. If the wire rope is installed wrong as shown in Figure 5–13, a permanent set will develop at the point where the wire rope enters the socket. This permanent set will weaken the wire rope and accelerate wear at this point.

Wedges and sockets shipped from the factory are stamped with size and type or pair identification. A socket or wedge may be stamped for two or more sizes of wire rope. The size on the socket and wedge must correspond with the size of wire rope being used. The wedge also has a “go”/“no-go” feature cast into the wedge to assist in determining the proper size wire rope that can be used with that particular socket and wedge. Refer to Figure 5–12. The proper size wire rope is determined when: 1) the wire rope passes through the “go” hole in the wedge, and 2) the wire rope does not pass through the “no-go” hole in the wedge. The part number may also be stamped on the socket and wedge. Refer to the Parts Manual for confirmation. If there is any doubt as to the mating of the socket and wedge, contact a Link-Belt Distributor.

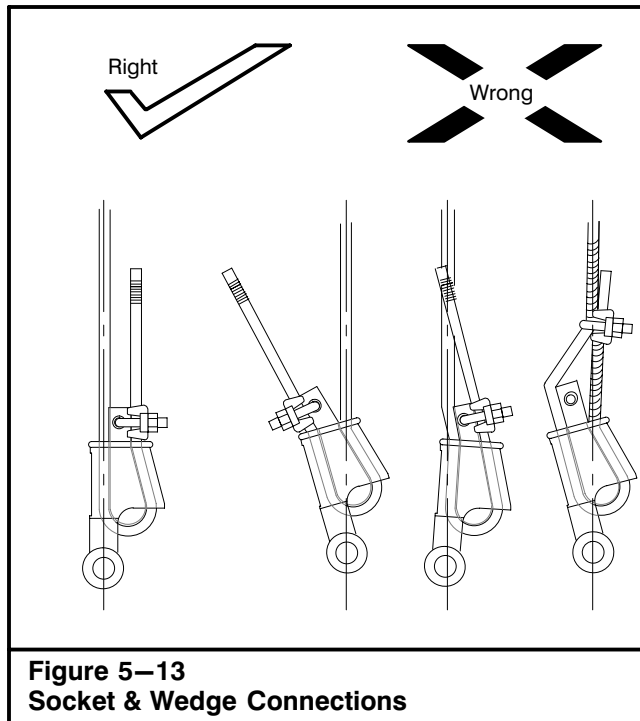

Before installing type ZB wire rope into a socket or wedge attach two seizings (hose clamps are an effective and efficient alternative if traditional seizings are not available) approximately 3–4 ft (0.9–1.2 m) from the end with a 3 in (76.2 mm) space between them. Refer to Figure 5-12.

The dead end must also be seized and a minimum tail length of 20 wire rope diameters [15" (.38m) for 3/4" (19mm) wire rope] for rotation resistant wire ropes and 6 wire rope diameters minimum for 6 to 8 strand wire rope is required. Refer to Figure 5-12. The seizings will help prevent core slippage and any looseness of the outer strands from traveling up the wire rope during installation while still allowing the wire rope strands to be free to adjust. If using type ZB wire rope, remove seizings from the live end after wire rope is securely installed into the socket.

Note: Refer to Figure 5-9 to identify which type of wire rope is installed on the crane.

Use a hammer to seat the wedge and wire rope into the socket before applying first load. Lift the first load a few inches (centimeters) from the ground to fully seat the wedge and wire rope in the socket. This load should be of equal or greater weight than loads expected in use.

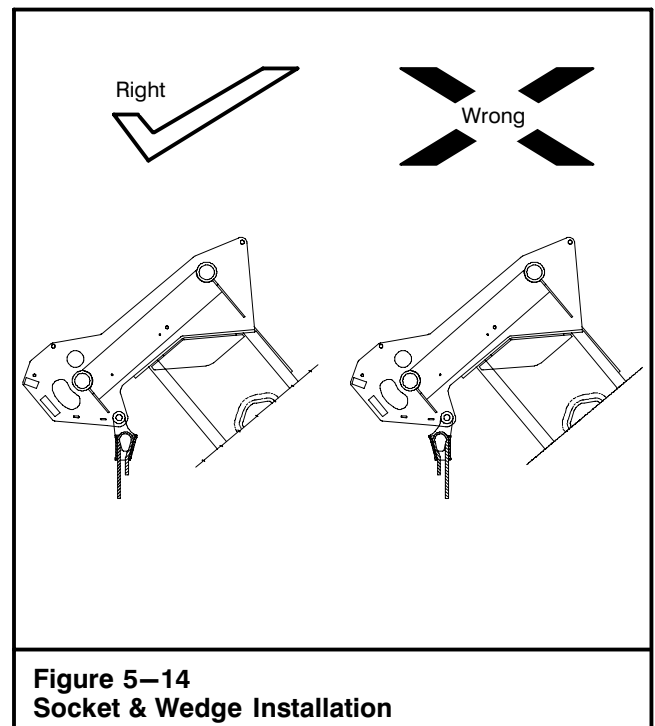

Secure the dead end section of the wire rope by installing the clip through the wedge as shown in Figure 5-12. Tighten the nuts on the clip to the recommended torque as shown on the table in Figure 5-16.

When anchoring the socket to the boom head, ensure the flat face is facing out as shown in Figure 5-14. If socket is not installed correctly structural damage to the boom head may occur.

It is recommended that the wire rope socket and wedge connection be reestablished on an annual basis. This can be accomplished by cutting the wire rope 6 in (0.15m) above the socket and wedge connection. See "Cutting Wire Rope" in this Section of this Operator's Manual. Install the socket and wedge connection as shown in Figure 5-13.

Wire Rope Break-In

After the wire rope has been installed and the ends secured in the correct manner, the new wire rope must be run through a break-in period. This allows the component parts of the new wire rope to gradually adjust itself to actual operating conditions.

1. Level the crane on fully extended outriggers with all tires clear of the ground. Position the upper over the front of the carrier and engage the travel swing lock.
2. Fully raise and fully extend the boom. Attach a light load at the hook and raise it a few inches (centimeters) off the ground. Allow to stand for several minutes.

Operator's Manual

3. Run the wire rope through a cycle of operation at very slow speeds. During this trial operation, a very close watch should be kept on all working parts—sheaves, drums, roller, etc. to make certain that the wire rope runs freely, and without any obstructions as it makes its way through the system.

Note: Run these loads with reeving that places the loads on the hook block with all wire rope off the drum except the last three wraps. If this is not possible, alternate methods must be used to assure proper tensioning of the wire rope on the drum.

4. If no problems appear in running the wire rope, repeat procedure with an increased load.

Single Part Line Hoisting

Non-rotating, rotation-resistant, or spin-resistant wire ropes are recommended for single part of line applications. This is of utmost importance for long fall hoist line applications. Link-Belt type “RB”, “ZB”, and “GC” are examples of wire ropes recommended for single part hoisting. See the Wire Rope Capacity Chart in the Crane Rating Manual for the specific types of rotation resistant wire rope recommended for your crane.

The use of non-rotation resistant wire rope is **not** recommended for long falls of single part of line hoisting since the wire rope and load may spin. If the crane operator allows either the load or the wire rope to rotate, the crane or wire rope can be damaged. The anti-two block weight may also become entangled with the wire rope and could damage the anti-two block system, wire rope, and/or head machinery.

Hook Ball Usage With Rotation Resistant Wire Rope

The rotation resistant characteristic is achieved by laying the outer strands around an independent wire rope that is wound in the opposite direction. When the wire rope has tension on it, opposing rotational forces are created between the core and outer strands. If a swivel hook ball is utilized with rotation resistant wire rope, the wire rope is

allowed to twist. The outer strands unwind and get longer while the inner core is forced to rotate in the same direction and shortens in length. As a result of this treatment, the inner core sees a disproportionately greater load, and core damage may occur due to shock loading or overloading. A rotating load on an unrestrained, non-swivel hook ball without a tagline, also affects the internal loading of the wire rope in this manner. This practice, or any other which allows the wire rope to rotate while in service, leads to unbalanced loading between the inner and outer layer of strands, which may result in core failure. Wire rope manufacturer's testing has shown that rotation resistant wire rope utilized with a swivel hook ball has reduced the breaking strength by as much as 50% if excessive rotation occurs.

Non-Swivel Usage

A non-swivel hook ball in conjunction with a tagline or other device to control load spin should be used when the crane is equipped with rotation resistant wire rope. This is to avoid unrestrained rotation of the wire rope.

Swivel Usage

A swivel hook ball can be used with rotation resistant wire rope if:

1. The wire rope is not shock loaded or overloaded.
2. Wire rope working strength is reduced to maintain original design factors.
3. The wire rope is inspected frequently as outlined below.

Wire Rope Inspection

Marked reduction in diameter indicates deterioration of the core resulting in lack of proper support for the load carrying strands. Excessive wire rope stretch or elongation may also be an indication of internal deterioration. Major concerns and replacement recommendations include:

1. Loss of wire rope diameter (in excess of those listed in the table in “Wire Rope Replacement” in this Operator's Manual), abnormal lengthening of wire rope lay, or protrusion of wires between the outer strands.
2. 2 randomly distributed broken wires in 6 wire rope diameters, or 4 randomly distributed broken wires in 30 wire rope diameters.

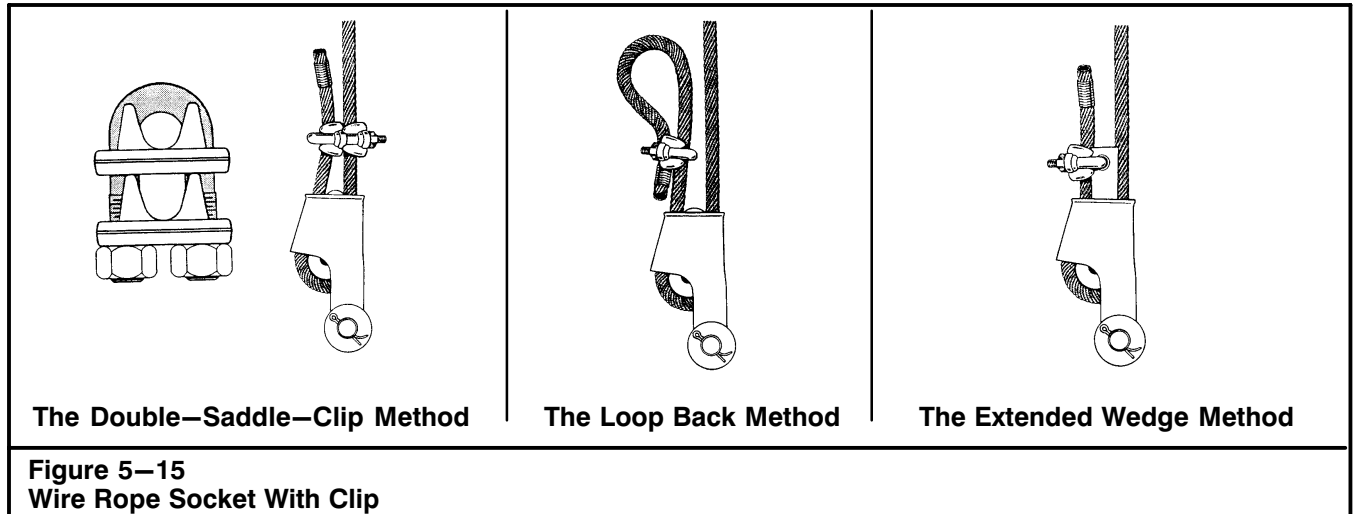

Wire Rope Sockets With Clips

Some codes require the use of a wire rope clip in conjunction with a socket and wedge connection. Figure 5-15 illustrates some typical methods of clip installation with sockets. In some cases, particularly in wrecking ball work, there is a chance that the wedge can loosen, releasing the socket from the wire rope. This could be caused by the banging action and alternate loading and unloading of the wire rope that occurs during this type work.



WARNING

Regularly inspect the integrity of the wire rope at the point of exit at the dead end side. High velocity spin of wire rope when loading and unloading can cause the wire rope to flip-flop, fatigue, and finally break off.

The use of wire rope clips with a socket and wedge connection can weaken the connection if done improperly. Do not attach the dead end of the wire rope to the live side with the clip as this will seriously weaken the connection. The clip may ultimately take the load and may deform or break the wire rope.

If using the loop back method, the loop formed must not be allowed to enter the wedge, or the connection will be weakened. The tail length of the dead end must be a minimum of 20 wire rope diameters [15" (.38m) for 3/4" (19mm) wire rope].

CAUTION

The ends of type ZB wire rope must be fuse welded and the tail length of the dead end must be a minimum of 20 wire rope diameters (15 in for 3/4 in wire rope). Failure to do so may cause the core to slip and/or the strands to loosen causing major wire rope damage.

Wire Rope Clip Installation

The correct method of installing wire rope clips is shown in Figure 5-17. The u-bolt must always be over the short end of the wire rope and the base must always contact the long end.

Clips should NOT be staggered, that is u-bolt of one clip over short end and u-bolt of next clip over long end. This practice will not only distort the wire rope excessively, but will prevent maximum capacity of this type fastening. Placing all clips with the u-bolt over the long end of the wire rope will damage strands and result in an unsafe condition.

The distance between clips should be not less than six times the wire rope diameter. In relation to size of wire rope, the minimum number of clips recommended for safe connections is given in Figure 5-16.

CAUTION

Apply the initial load and retighten nuts to the recommended torque. Wire rope can stretch and reduce in diameter when loads are applied. Inspect periodically and retighten as required.

Operator's Manual

| Clip Size | | Minimum No. of Clips | Amount OF Wire Rope To Turn Back* | | Torque | |
|-----------|------|----------------------|-----------------------------------|-------|--------|-------|
| Inches | mm | | Inches | mm | ft lb | Nm |
| 1/4 | 3.2 | 2 | 3-1/4 | 82.5 | --- | --- |
| 3/16 | 4.7 | 2 | 3-3/4 | 95.2 | --- | --- |
| 1/4 | 6.3 | 2 | 4-3/4 | 120.6 | 15 | 20.0 |
| 5/16 | 7.9 | 2 | 5-1/4 | 133.3 | 30 | 40.7 |
| 3/8 | 9.5 | 2 | 6-1/2 | 165.1 | 45 | 60.1 |
| 7/16 | 11.1 | 2 | 7 | 177.8 | 65 | 86.8 |
| 1/2 | 12.7 | 3 | 11-1/2 | 292.1 | 65 | 86.8 |
| 9/16 | 14.3 | 3 | 12 | 304.8 | 95 | 126.9 |
| 5/8 | 15.9 | 3 | 12 | 304.8 | 95 | 126.9 |
| 3/4 | 19.0 | 4 | 18 | 457.2 | 130 | 173.6 |

* If a greater number of clips are used than shown in this table, the amount of wire rope turnback should be increased proportionally.

Figure 5-16
Wire Rope Clip Application Recommendation

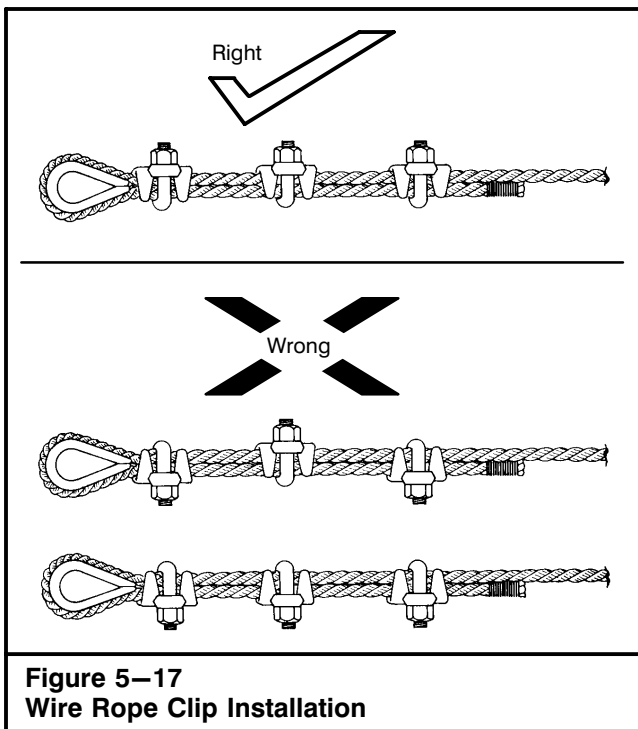

Figure 5-17
Wire Rope Clip Installation

Cutting Wire Rope

CAUTION

The ends of type ZB wire rope must be fuse welded. Failure to do so may cause the core to slip and/or the strands to loosen causing major wire rope damage.

When wire rope is to be cut, seizings should be placed on each side of the point where the wire rope is to be cut, to keep the strands in place. On preformed wire rope such as type RB, one seizing on each side of the cut is enough. On non-preformed wire rope less than 7/8 in (22mm) diameter such as type ZB, two seizings are recommended. On non-preformed wire rope over 7/8 in (22mm) diameter, three seizings are recommended. Original wire rope lay must be maintained at all times.

Three basic methods of cutting wire rope are recommended:

1. Abrasive cutting tools.
2. Shearing tools. (Wire cutters on small wire rope, a wire rope cutter and hammer for larger wire ropes.)
3. Oxy/acetylene fuel torch. This is the only suggested method for cutting type ZB wire rope.

Operator's Manual

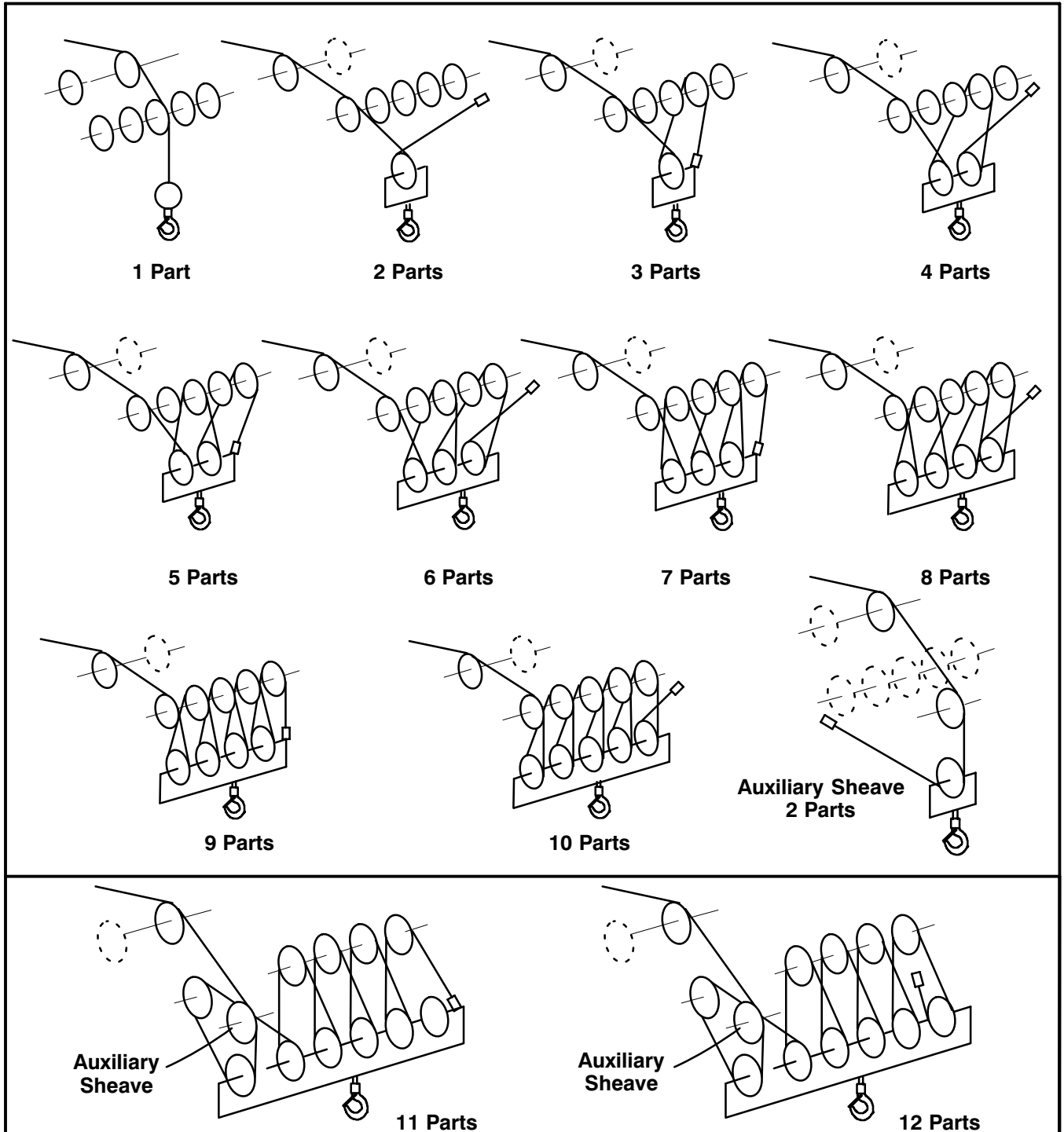

CAUTION

These reevings are only applicable for maximum rated capacity lifts that require additional parts of line to maintain the required wire rope safety factor.

Note: Reeve the wire rope to equalize the loading on the boom head sheaves. Some of the diagrams shown may not apply to this particular crane. Do not use a swivel at the dead end of a multi-part reeving. Reeving shown is typical. Either drum may be reeved over head sheaves or auxiliary sheave.

Figure 5-18
Wire Rope Reaving Diagrams

Operator's Manual

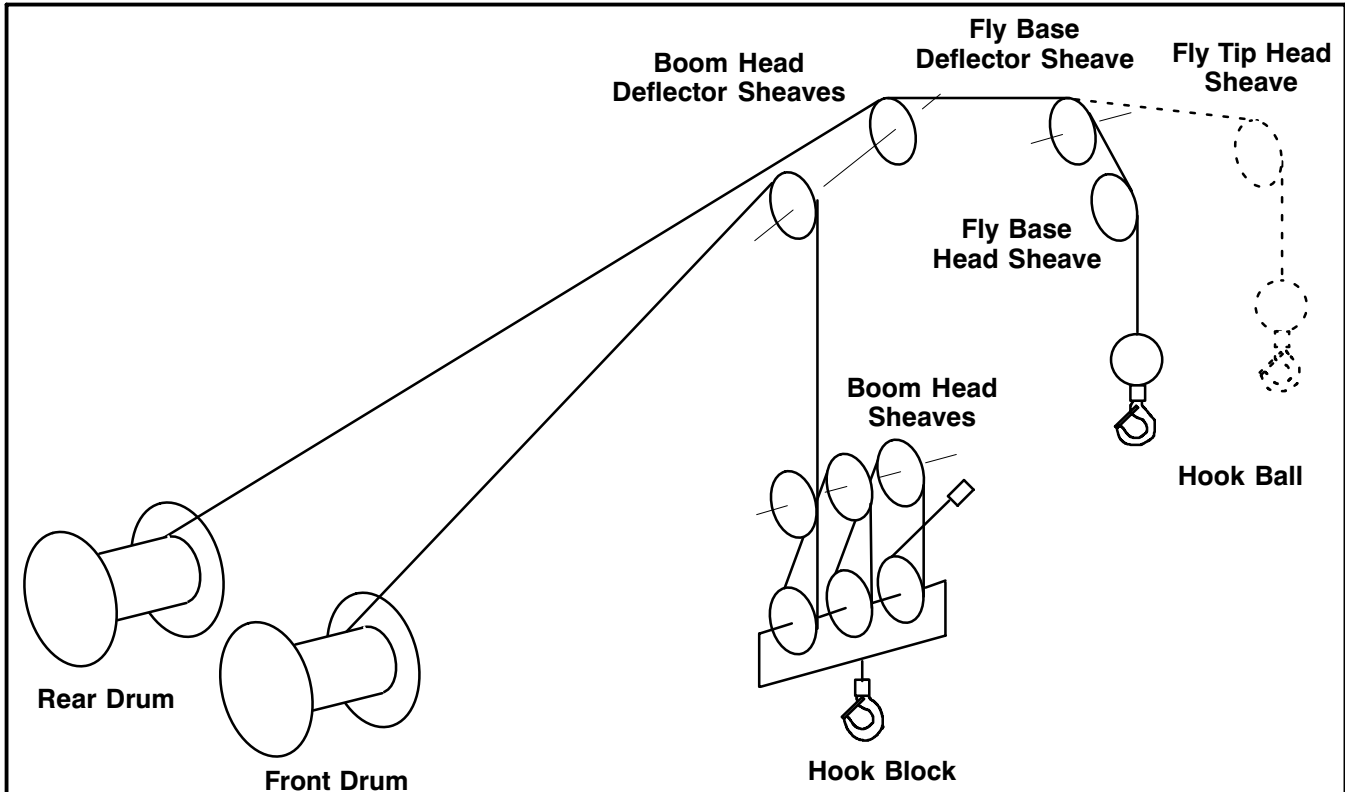

Note: Reeving shown is typical. Either drum may be reeved over boom sheaves or fly sheaves.

Figure 5-19
Wire Rope Reeving Diagrams

Operator's Manual

Event Data Recording

This Link-Belt crane is equipped with one or more computers that monitor and/or control the crane's performance. This crane uses computer modules to monitor and retain crane operation, crane configuration, and as well as crane functions. These modules may aid the operator in the operation of the crane. The modules may also store data to help the Link-Belt dealer/distributor technician service the crane.

Event Data Recorder

This Link-Belt crane has an Event Data Recorder (EDR) system. The main purpose of the EDR is to record data relating to the crane operation and configuration that will assist in understanding how the crane's operating systems perform. The EDR is designed to record data related to crane dynamics and safety systems for a short period of time. The EDR in this crane is designed to record such data as:

- How various systems in the crane were operating
- How the crane was configured (counterweight, boom length, operational mode, etc.)
- What control functions were being used

This data will help provide valuable information as to how the crane was functioning and/or being operated.

Data And Recording Privacy

Important: EDR data is recorded in the crane only if a non-trivial situation occurs; no data is recorded by the EDR under normal operating conditions and no personal data (e.g., name, gender, age, or crane location) is recorded. However, other parties, such as law enforcement, or similar government offices, could combine the EDR data with the type of personal identifying data routinely acquired during a crane accident investigation.

To read data recorded by this EDR system, special equipment is required, and access to the crane and/or the EDR is needed. Link-Belt has the special equipment necessary to retrieve the recorded data.

It is the position of Link-Belt that the crane owner owns any data that is recorded and stored in the EDR or other onboard computer system(s). Link-Belt will not access this data, interpret data, or share the data with others, except by written request from the crane owner(s). The request by the crane owner may be due to an official request of police or similar government offices; as part of Link-Belt's defense of litigation through the discovery process; or as required by law. Data that Link-Belt retrieves may also be used for Link-Belt or component manufacturers for research purposes, where a need is shown and data is not tied to a specific crane or crane owner.

Link-Belt will retrieve crane data only by written request from the crane owner. The Electronic Data Recorder Request Form found at the end of this Operator's Manual can be used for this purpose.

Operator's Manual

Crane Specifications

The following information is general in nature and is used for reference purposes only. Depending upon the vintage of the crane, some features may no longer be available. Standard and optional features may vary from crane to crane. Contact a Link-Belt Distributor or the Factory to verify the specific information if required.

General Dimensions

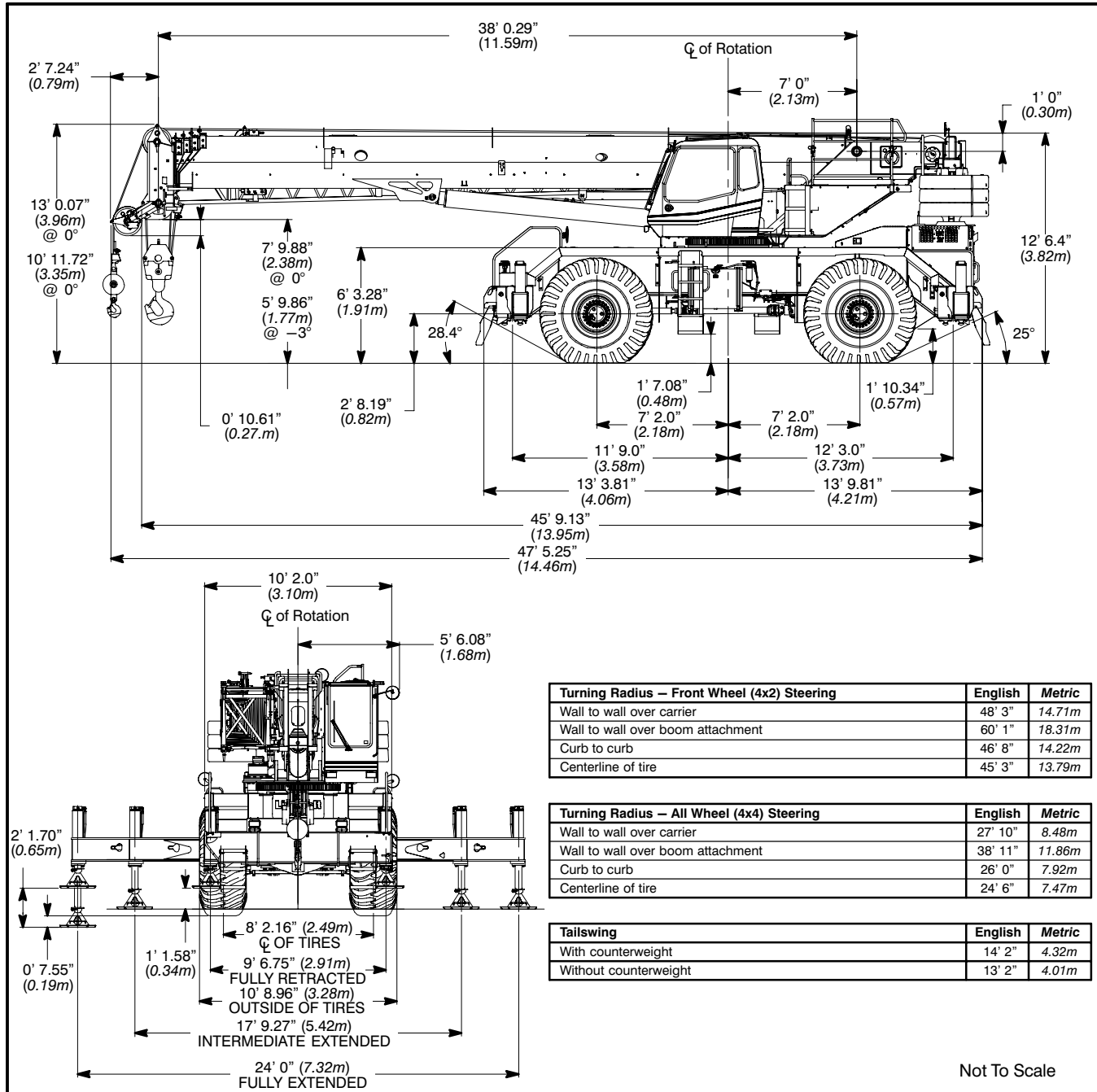

Figure 5-20
General Dimensions

Boom, Attachments, and Upper Structure

■ Boom

Design – Five section, formed construction of extra high tensile steel consisting of one base section and four telescoping sections. The two plate design of each section has multiple longitudinal bends for superior strength. Each telescoping section extends independently by means of one double-acting, single stage hydraulic cylinder with integrated holding valves.

Boom

- 38–140 ft (11.6–42.7m) five section boom
- Three boom extend modes (EM1 through EM3), controlled from the operator's cab, provide superior capacities by varying the extension of the telescoping sections:
 - EM1 extends to 140.0 ft (42.7m)
 - EM2 extends to 115.8 ft (35.3m)
 - EM3 extends to 76.5 ft (23.3m)
- Mechanical boom angle indicator
- Maximum tip height for each extend mode is:
 - EM1 is 149 ft 7 in (45.6m)
 - EM2 is 125 ft 9 in (38.3m)
 - EM3 is 87 ft 1 in (26.5m)

Boom Wear Pads

- Wear pads with Teflon inserts that self-lubricate the boom sections
- Bottom wear pads are universal for all boom sections
- Top wear pads are universal for all boom sections

Boom Head

- Five 16.5 in (41.9cm) root diameter nylon sheaves to handle up to ten parts of line
- Easily removable wire rope guards
- Wire rope dead end lugs on each side of the boom head
- Boom head is designed for quick-reeve of the hook block

Boom Elevation

- One double acting hydraulic cylinder with integral holding valve
- Boom elevation: -3° to 80°

Auxiliary Lifting Sheave – Optional

- Single 16.5 in (41.9m) root diameter nylon sheave
- Easily removable wire rope guards
- Does not affect erection of the fly or use of the main head sheaves

Hook Blocks and Balls – Optional

- 40 ton (36.3mt) 4 sheave quick-reeve hook block with safety latch
- 60 ton (54.4mt) 4 sheave quick-reeve hook block with safety latch
- 80 ton (72.5mt) 5 sheave quick-reeve hook block with safety latch
- 90 ton (80.0mt) 6 sheave quick-reeve hook block with safety latch
- 8.5 ton (7.7mt) swivel and non-swivel hook balls with safety latch
- 10 ton (9.1mt) swivel and non-swivel hook balls with safety latch

Fly – Optional

- 35 ft (10.7m) one piece lattice fly, stowable, offsettable to 2° , 15° , 30° , and 45° . Maximum tip height is 184 ft 2 in (56.1m).
- 35 ft–58 ft (10.7–17.7m) two piece bi-fold lattice fly, stowable, offsettable to 2° , 15° , 30° , and 45° . Maximum tip height is 206 ft 8 in (63.0m).

Fly Extensions – Optional

- One 16 ft (4.9m) lattice extension, equipped with two 16.5 in (41.9cm) root diameter nylon sheaves, to be mounted between the boom head and fly options. Maximum tip height is 222 ft 4 in (67.8m).
- Two 16 ft (4.9m) lattice extensions, one equipped with two 16.5 in (41.9cm) root diameter nylon sheaves, to be mounted between the boom head and fly options. Maximum tip height is 238 ft 2 in (72.6m). Minimum of 19,200 lb (8 700kg) of counterweight required.

Operator's Manual

■ Operator's Cab and Controls

Environmental Cab – Fully enclosed, one person cab of galvaneal steel structure with acoustical insulation Equipped with:

- Tinted and tempered glass windows
- Extra large fixed front window with windshield wiper and washer
- Swing up roof window with windshield wiper and washer
- Sliding left side door with large fixed window
- Sliding rear and right side windows for ventilation
- Six way adjustable, cushioned seat with seat belt and storage compartment
- Diesel fired warm-water heater with air ducts for front windshield defroster and cab floor
- Defroster fan for the front window
- Bubble level
- Circulating fan
- Adjustable sun visor
- Dome light
- Cup holder
- Fire extinguisher
- Left side viewing mirror
- Two position travel swing lock

Air Conditioning – Optional – Integral with cab heating system utilizing the same ventilation outlets

Engine Dependant Warm-Water Heater – Optional – With air ducts for front windshield defroster and cab floor

Steering Column – Pedestal type with tilt and telescope functions for operator comfort. Column includes the following controls and indicators:

Left and right levers include:

- Horn button
- Turn signal switch
- Driving light switch
- Transmission direction switch

Panel mounted switches for:

- Travel park brake
- Steer mode selector
- 2/4 wheel drive/range selector
- Transmission gear selector
- Hazard flasher

Panel mounted indicator/warning lights for:

- Transmission temperature
- Travel park brake
- Service brake
- Turn signals
- Rear wheel offset
- Emergency steer – optional

Armrest Controls – Two dual axis hydraulic joystick controllers or optional single axis hydraulic controllers for:

- Cab heater and A/C Controls
- Swing
- Boom hoist
- Main rear winch
- Auxiliary front winch – optional
- Drum rotation indication
- Drum rotation indicator activation switch
- Winch high/low speed and disable switch(es)
- Warning horn button
- Swing park brake
- Engine throttle lock

Outrigger Controls – Hand held control box with umbilical cord gives the operator the freedom to view operation while setting the outriggers.

Foot Controls

- Boom telescope
- Swing brake
- Engine throttle
- Service brake

Right Front Console – Controls and indicators for:

- Engine ignition
- Engine throttle lock
- Function disable
- Front windshield wiper and washer
- Cab floodlights
- Warning horn
- Console dimmer switch
- 12 volt power connections
- E-stop switch
- Ignition switch on indicator light
- Boom floodlight – optional
- Rotating beacon/Strobe light – optional
- Third wrap set and activate switches – optional

- Bubble level

Cab Instrumentation – Ergonomically positioned, analog instrumentation for crane operation including:

- Tachometer
- Engine water temperature
- Fuel level
- Hydraulic oil temperature
- Stop engine
- Check engine
- Wait to start
- DPF regeneration light
- DPF regeneration inhibit switch
- DPF regeneration initiate switch
- High exhaust temperature light
- Regeneration disabled light
- Swing park brake light
- Engine speed
- Engine oil pressure
- Battery voltage
- Fuel rate (gal/hr)
- Engine load
- Engine Diagnostics

Diagnostic Center – Mounted behind the operator's seat.

- Engine diagnostic
- RCL CANBUS diagnostic
- Crane Controller USB diagnostic
- RCL controller USB diagnostic

Operator's Manual

Link-Belt Pulse – The Link-Belt in-house designed, total crane operating system that utilizes the display as a readout and operator interface for the following systems:

- **Rated Capacity Limiter** – LCD graphic audio – visual warning system integrated into the dash with anti-two block and function limiter. Operating data includes:
 - Crane configuration
 - Boom length and angle
 - Boom head height
 - Allowed load and % of allowed load
 - RCL light bar
 - Boom angle
 - Radius of load
 - Actual load
 - Wind speed
 - Highlighted unit of measurement on working screen
 - Active pin/latch status
 - Telescope operation displayed in real time
 - Counterweight installation/removal
 - Third wrap indicator
 - Diagnostics
 - Operator settable alarms (include):
 - Maximum and minimum boom angles
 - Maximum tip height
 - Maximum boom length
 - Swing left/right positions
 - Operator defined area (imaginary plane)
- **Extend control module (ECM)**
 - Controls the extend modes
 - Diagnostics

Integrated Third Wrap Indicator – Optional – Link-Belt Pulse Color display visually and audibly warns the operator when the wire rope is on the first/bottom layer and when the wire rope is down to the last three wraps.

Internal RCL Light Bar – Optional – Visually informs the operator when crane is approaching maximum load capacity with a series of green, yellow, and red lights.

External RCL Light Bar – Optional – Visually informs the ground crew when crane is approaching maximum load capacity with a series of green, yellow, and red lights.

■ Swing

Motor/Planetary – Bi-directional hydraulic swing motor mounted to a planetary reducer for 360° continuous smooth swing at 1.9 rpm

Swing Park Brake – 360°, electric over hydraulic, (spring applied/hydraulic released) multi-disc brake mounted on the speed reducer. Operated by a switch from the operator's cab.

Swing Brake – 360°, foot operated, hydraulic applied disc brake mounted to the speed reducer

Swing Lock – Two-position swing lock (boom over front or rear) operated from the operator's cab

360° Positive Swing Lock – Optional – Meets New York City requirement

■ Electrical

Swing Alarm – Audio warning device signals when the upper is swinging.

Lights

- Two working lights on front of the cab
- One rotating amber beacon on top of the cab – optional
- One amber strobe beacon on top of the cab – optional
- Boom floodlight – optional

Operator's Manual

■ Load Hoist System

Load Hoist Performance

| Main (Rear) and Auxiliary (Front) Winches – 3/4 in (19mm) Wire Rope | | | | | | | | | | |
|---|-------------------|-------|-------------------|-------|-----------------|-------|-------|------|-------|-------|
| Layer | Maximum Line Pull | | Normal Line Speed | | High Line Speed | | Layer | | Total | |
| | lb | kN | ft/min | m/min | ft/min | m/min | ft | m | ft | m |
| 1 | 16,880 | 75.09 | 172 | 52.4 | 341 | 104.0 | 114 | 34.7 | 114 | 34.7 |
| 2 | 15,519 | 69.03 | 187 | 57.0 | 371 | 113.1 | 124 | 37.8 | 238 | 72.5 |
| 3 | 14,362 | 63.89 | 202 | 61.6 | 401 | 122.2 | 134 | 40.8 | 372 | 113.4 |
| 4 | 13,365 | 59.45 | 217 | 66.1 | 430 | 131.1 | 144 | 43.9 | 516 | 157.3 |
| 5 | 12,497 | 55.59 | 232 | 70.7 | 460 | 140.2 | 154 | 46.9 | 670 | 204.2 |
| 6 | --- | --- | --- | --- | --- | --- | 164 | 50.0 | 834 | 254.2 |

| Wire Rope Application | | Diameter | | Type | Maximum Permissible Load | |
|-------------------------|----------|----------|----|--|--------------------------|-------|
| | | in | mm | | lb | kN |
| Main (Rear) Winch | Standard | 3/4 | 19 | 18x19 rotation resistant – right regular lay (Type RB) | 12,920 | 57.47 |
| | Optional | 3/4 | 19 | 4 strand, low torque, right regular lay (Type GC) | 22,400 | 99.64 |
| | Optional | 3/4 | 19 | 34x7 rotation resistant – right regular lay (Type ZB) | 15,600 | 69.39 |
| Auxiliary (Front) Winch | Standard | 3/4 | 19 | 18x19 rotation resistant – right regular lay (Type RB) | 12,920 | 57.47 |
| | Optional | 3/4 | 19 | 4 strand, low torque, right regular lay (Type GC) | 22,400 | 99.64 |
| | Optional | 3/4 | 19 | 34x7 rotation resistant – right regular lay (Type ZB) | 15,600 | 69.39 |

2M Main and Optional Auxiliary Winches

- Axial piston, full and half displacement (2-speed) motors driven through planetary reduction unit for positive control under all load conditions.
- Grooved lagging
- Power up/down mode of operation
- Hoist drum cable follower – optional
- Drum rotation indicator
- Drum diameter: 16 in (40.6cm)
- Wire rope length:
 - Main: 730 ft (222.5m)
 - Auxiliary: 500 ft (152.4m) or 730 ft (222.5m)
- Maximum wire rope storage: 834 ft (254.2m)
- Terminator style socket and wedge

Third wrap indicator – optional – Visually and audibly warns the operator when the wire rope is on the first/bottom layer and when the wire rope is down to the last three wraps

■ Hydraulic System

Counterbalance Valves – All hoist motors, boom extend cylinders, and boom hoist cylinders are equipped with counterbalance valves to provide load lowering and prevents accidental load drop when hydraulic power is suddenly reduced.

Hydraulic Oil Coolers – One carrier mounted cooler removes heat from the hydraulic oil. Remote mounted on right side of the carrier.

■ Counterweight

Standard – Total of 19,200 lb (8 709.0kg) counterweight consisting of two counterweights pinned to the upper with capacities for:

- 0 lb (0kg) counterweight*
- 9,600 lb (4 354.5kg) counterweight
- 19,200 lb (8 709.0kg) counterweight

Optional – 9,600 lb (4 354.5kg) in addition to standard counterweight for a total of 28,800 lb (13 063.0kg) counterweight with capacities for:

- 0 lb (0kg) counterweight*
- 9,600 lb (4 354.5kg) counterweight
- 19,200 lb (8 709.0kg) counterweight
- 28,800 lb (13 063.0kg) counterweight*

* Travel speed limited to 5 mph.

Optional – Hydraulic counterweight removal activated by a hand-held controller with enough cable to access the pins on each side of the counterweights.

Carrier

■ General

- 10 ft 9 in (3.28m) wide
- 14 ft 4 in (4.37m) wheelbase (centerline of first axle to centerline of second axle)

Frame – Box-type, torsion resistant, welded construction made of high tensile steel. Equipped with front and rear towing and tie-down lugs, tow connections, and access ladders.

Operator's Manual

■ Outriggers

Boxes – Two double box, front and rear welded to carrier frame

Beams and Jacks – Four single stage beams with Confined Area Lifting Capacities (CALC™) provide selectable outrigger extensions of full, intermediate, and retracted. Hydraulically controlled from the operator's cab with integral check valves.

Pontoons – Four lightweight, quick release, 23.5 x 23.5 in (59.7 x 59.7cm), steel pontoons with contact area of 460 in² (2 968cm²) can be stored for road travel in storage racks on the carrier.

Main Jack Reaction – 108,000 lb (48 988kg) force and 235 psi (1 620kPa) ground bearing pressure

■ Steering and Axles

Steering – Four independent modes consisting of two wheel front, two wheel rear, four wheel, and crab. Each mode is controlled from the steering wheel and is selected by a switch in the operator's cab.

Drive – Two modes: 4 x 2 and 4 x 4 for off highway travel

Axle 1 – Steered, non-driven for 4 x 2 and steered, driven for 4 x 4

Axle 2 – Steered, driven

■ Suspension

Front – Rigid mount to the carrier frame

Rear – The rear axle is suspended on the oscillation cylinders with motion of the axle controlled by a four bar linkage system. The oscillation cylinders lockout when the upper structure rotates 2.5° past centerline.

- Hydro-gas rear suspension – optional

Ride Height Adjustment – Suspension can be lowered for transport using a hand-held controller from level ground.

■ Tires and Wheels

Front and Rear – Four (single) 29.5 x 25–28 ply rating, earthmover type tires on steel disc wheels

- Spare tires and wheels – optional

■ Brakes

Service – Full hydraulic, dual circuit, disc type brakes on all wheel ends

Parking/Emergency – Spring applied type, acting on front axle

■ Electrical

Two batteries provide 12 volt starting and operation

Lights

- Front lighting includes two main headlights and two parking/directional indicators.
- Side lighting includes two parking/directional indicators per side.
- Rear lighting includes two parking/directional indicators, two parking/brake lights, and two reversing lights.
- Other equipment includes hazard/warning system, cab light, instrument panel light, and signal horn.

■ Engine

| Specification | Cummins QSB |
|--|--|
| Numbers of Cylinders | 6 |
| Cycle | 4 |
| Emissions Compliance Level: | Tier 4i/Stage IIIB |
| Bore and Stroke: inch (mm) | 4.21 x 4.88 (107 x 124) |
| Piston Displacement: in ³ (L) | 408 (6.7) |
| Max. Brake Horsepower: hp (kW) | 270 (201) @ 2,000 rpm 260 (194) @ 2,200 rpm |
| Peak Torque: ft lb (Nm) | 730 (990) @ 1,500 rpm |
| Electric/starting systems: volts | 12/12 |
| Alternator: amps | 160 |
| Crankcase Capacity: qt (L) | 18.5 (17.5) |
| <ul style="list-style-type: none">• Water/fuel separator w/ heater and water in fuel (WIF) sensor• 120-volt block heater• Grid heater – 200 amp• Mechanically driven variable speed engine control viscous fan clutch | |

■ Transmission

Powershift – Three speed with high/low range for 6 forward and 6 reverse gears. Front axle disconnect for two or four wheel drive. Front axle disconnects in high range.

Operator's Manual

■ Carrier Speeds and Gradeability

| Spicer | | Ratio | Speed | | Gradeability (@ stall) |
|--------|------------------------------|-------|-------|-----------|------------------------|
| Gear | | | mph | km/h | % Grade |
| 6th | Forward & Reverse 2WD/Hi | 0.82 | 18.2 | 29.2 9 | 2.4 |
| 5th | | 2.25 | 7.7 | 12.3 9 | 10.2 |
| 4th | | 4.67 | 3.8 | 6.12 | 23.8 |
| 3rd | Forward & Reverse 4WD/Low | 2.4 | 7.3 | 11.7 5 | 11.0 |
| 2nd | | 6.54 | 2.7 | 4.35 | 35.2 |
| 1st | | 13.6 | 1.3 | 2.09 | 101.2 |

Based on a gross vehicle weight of 105,500 lb (47 854kg).
Crane operating angle must not exceed 35° (77% grade).

■ Fuel Tank

One 75 gallon (283.9L) capacity tank

■ Hydraulic System

All functions are hydraulically powered allowing positive precise control with independent or simultaneous operation of all functions.

Main Pumps

- One two section fixed displacement gear pump for the front/rear winches and boom hoist/telescope circuits.
- One two section fixed displacement gear pump for the swing/steering and outrigger/telescope/service brake/oscillation circuits.
- One two section gear pump for an additional supply to the front/rear winch circuit and the hydraulic oil cooler fan drive.
- Combined pump capacity of 138 gpm (522.4Lpm)

Hydraulic Reservoir – 153 gal (579.2L) capacity equipped with sight level gauge. Diffusers built in for deaeration.

Filtration – One 10 micron, full flow return line filter. Accessible for easy filter replacement.

■ Pump Drive

One pump is mounted on the engine with the rest being transmission mounted. All pumps are mechanically driven by the diesel engine.

- Front/rear winches and boom hoist/telescope pump can be disconnected with a manual pump disconnect to aid in cold weather starting – optional.

Operator's Manual

Axle Loads

| Base crane with zero counterweight and full tank of fuel | Gross Vehicle Weight ⁽¹⁾ | | Upper Facing Front | | | | Upper Facing Rear | | | |
|---|-------------------------------------|--------|--------------------|--------|------------|--------|-------------------|--------|------------|--------|
| | | | Front Axles | | Rear Axles | | Front Axles | | Rear Axles | |
| | lb | kg | lb | kg | lb | kg | lb | kg | lb | kg |
| | 79,919 | 36 251 | 51,085 | 23 172 | 28,834 | 13 079 | 22,585 | 10 245 | 57,334 | 26 007 |
| Pintle hook, front | 13 | 6 | 17 | 8 | -5 | -2 | 17 | 8 | -5 | -2 |
| Pintle hook, rear | 13 | 6 | -5 | -2 | 18 | 8 | -5 | -2 | 18 | 8 |
| Rear steer indicator | 6 | 3 | 0 | 0 | 6 | 3 | 0 | 0 | 6 | 3 |
| Hydro-gas suspension | 56 | 25 | 20 | 9 | 36 | 16 | 20 | 9 | 36 | 16 |
| Pump disconnect | 39 | 18 | 7 | 3 | 32 | 15 | 7 | 3 | 32 | 15 |
| Operator in cab | 250 | 113 | 140 | 64 | 110 | 50 | 110 | 50 | 140 | 64 |
| Hoist drum follower – main | 69 | 31 | -24 | -11 | 93 | 42 | 93 | 42 | -24 | -11 |
| Auxiliary winch with 500 ft (152.4m) wire rope | 608 | 276 | -74 | -34 | 682 | 309 | 682 | 309 | -74 | -34 |
| Hoist drum follower – auxiliary | 69 | 31 | -6 | -3 | 75 | 34 | 75 | 34 | -6 | -3 |
| Substitute 500 ft (152.4m) wire rope with 730 ft (222.5m) – auxiliary | 288 | 131 | -9 | -4 | 297 | 135 | 297 | 135 | -9 | -4 |
| Remove 730 ft (222.5m) wire rope from rear (main) winch | -931 | -422 | 203 | 92 | -1,134 | -514 | -1,134 | -514 | 203 | 92 |
| Remove 500 ft (152.4m) wire rope from front (auxiliary) winch | -643 | -292 | 21 | 10 | -664 | -301 | -664 | -301 | 21 | 10 |
| Counterweight removal | 208 | 94 | -62 | -28 | 270 | 122 | 270 | 122 | -62 | -28 |
| One slab of counterweight on upper | 9,600 | 4 355 | -3,356 | -1 522 | 12,956 | 5 877 | 12,956 | 5 877 | -3,356 | -1 522 |
| Two slabs of counterweight on upper | 19,200 | 8 709 | -6,712 | -3 045 | 25,912 | 11 754 | 25,912 | 11 754 | -6,712 | -3 045 |
| Three slabs of counterweight on upper | 28,800 | 13 064 | -10,068 | -4 567 | 38,868 | 17 630 | 38,868 | 17 630 | -10,068 | -4 567 |
| Emergency steering | 255 | 116 | 39 | 18 | 216 | 100 | 216 | 100 | 39 | 18 |
| 360° mechanical swing lock | 140 | 64 | 72 | 33 | 68 | 31 | 68 | 31 | 72 | 33 |
| Air conditioning | 179 | 81 | 50 | 23 | 129 | 59 | 129 | 59 | 50 | 23 |
| Floodlight to front of boom base section | 7 | 3 | 10 | 5 | -3 | -1 | -3 | -1 | 10 | 5 |
| Fly mounting brackets to boom base section for fly options | 176 | 80 | 239 | 108 | -63 | -29 | -63 | -29 | 239 | 108 |
| 35 ft (10.67m) offsettable fly – stowed | 1,591 | 722 | 2,576 | 1 168 | -984 | -446 | -984 | -446 | 2,576 | 1 168 |
| 35–58 ft (10.67–17.68m) offsettable fly – stowed | 2,263 | 1 026 | 3,257 | 1 477 | -994 | -451 | -994 | -451 | 3,257 | 1 477 |
| Auxiliary lifting sheave | 110 | 50 | 304 | 138 | -194 | -88 | -194 | -88 | 304 | 138 |
| 90 ton (80.0mt) 6-sheave hook block at bumper | 1,554 | 705 | 2,358 | 1 070 | -804 | -365 | -804 | -365 | 2,358 | 1 070 |
| 80 ton (72.5mt) 5-sheave hook block at bumper | 1,406 | 638 | 2,134 | 968 | -728 | -330 | -728 | -330 | 2,134 | 968 |
| 60 ton (54.4mt) 4-sheave hook block at bumper | 1,109 | 503 | 1,683 | 763 | -574 | -260 | -574 | -260 | 1,683 | 763 |
| 10 ton (9.1mt) hook ball at bumper | 550 | 250 | 834 | 378 | -284 | -129 | -284 | -129 | 834 | 378 |
| 8.5 ton (7.7mt) hook ball at bumper | 360 | 163 | 546 | 248 | -186 | -84 | -186 | -84 | 546 | 248 |
| 90 ton (80.0mt) 6-sheave hook block at boom head | 1,554 | 705 | 4,138 | 1 877 | -2,584 | -1 172 | -2,584 | -1 172 | 4,138 | 1 877 |
| 80 ton (72.5mt) 5-sheave hook block at boom head | 1,406 | 638 | 3,744 | 1 698 | -2,338 | -1 061 | -2,338 | -1 061 | 3,744 | 1 698 |
| 60 ton (54.4mt) 4-sheave hook block at boom head | 1,109 | 503 | 2,953 | 1 340 | -1,844 | -836 | -1,844 | -836 | 2,953 | 1 340 |
| 10 ton (9.1mt) hook ball at boom head | 550 | 250 | 1,465 | 665 | -915 | -415 | -915 | -415 | 1,465 | 665 |
| 8.5 ton (7.7mt) hook ball at boom head | 360 | 163 | 959 | 435 | -599 | -272 | -599 | -272 | 959 | 435 |

| Tire | Maximum Allowable Axle Load @ 20 mph (32.2km/h) |
|-------------------|---|
| 29.5 x 25 (28–PR) | 55,000 lb (24 948kg) |

(1) Adjust gross vehicle weight and axle loading according to component weight.

Note: All weights are ±3%.

Table Of Contents

Fundamental Terms 6-1

Operator's Manual

Fundamental Terms

Many terms are used which refer to crane function, assembly, operation, and maintenance. The following list gives a brief definition as to how the terms are used in this Operator's Manual and how they fit this particular crane.

Accumulator: A container in which fluid is stored under pressure as a source of hydraulic energy.

Aeration: The condition when air is present in the hydraulic fluid. This causes the fluid to appear milky and components to operate erratically because of the compressibility of air trapped in the fluid.

Annually: Once a year

Anti-Two Block System: A system of electromechanical devices used to alert or prevent the crane operator from two blocking the crane. See "Two Block".

Attachment: The boom assembly, offset fly section, auxiliary lifting sheave, or the combination of them.

Audio/Visual Warning System: Alarm device that signals the operator of low engine oil pressure, high engine coolant temperature, and high hydraulic oil and transmission oil temperature. See "Rated Capacity Indicator" or "Rated Capacity Limiter".

Automatic Brake: Drum brake system that is applied automatically when the drum control lever is in neutral.

Auxiliary Lifting Sheave: A unit which connects to the boom head and is used for reeving winch rope for a second winch drum.

Backward Stability: Resistance to overturning of the crane in a rearward direction.

Base Section: The segment of the boom which attaches to the upper frame by the boom foot pin.

Boom: The assembly of the base, T1, T2, T3, and T4 sections used as the telescoping extension.

Boom Angle: The angle above or below horizontal of the longitudinal axis of the boom base section.

Boom Angle Indicator: An accessory which measures the horizontal angle of the boom.

Boom Foot: Base of boom where it attaches to the upper revolving frame.

Boom Hoist: The hydraulic method of raising and lowering the boom to different boom angles.

Boom Length: The straight line through the centerline of the boom foot pin to the centerline of the boom head sheave shaft, measured along the longitudinal axis of the boom.

Boom Section: The base, T1, T2, T3, and T4 segments which are used as the telescoping extension.

Bypass: A secondary passage of fluid flow, in addition to the main flow path.

Capacity Chart: The chart(s) in the Crane Rating Manual in the crane which give rated lifting capacities for the crane under different load conditions.

Carrier: The portion of the crane located below the turntable bearing.

Carrier Frame: The main structure of the carrier section of the crane.

Cavitation: A condition where air is induced into a cavity, line, or chamber normally filled with oil. This condition can cause damage to pumps, cylinder walls, etc.

Check Valve: A valve which permits flow in one direction only.

Circuit: A complete or partial path over which current or fluid may flow.

Closed Center Circuit: The condition where the fluid only flows through the main control valves when a control valve spool is actuated. This can be done two different ways: (1) using a pressure compensated pump, or (2) using a fixed displacement pump, unloading valve, and an accumulator.

Collector Ring (Slip Ring): A device used to transmit the electrical power from the carrier to the upper utilizing a rotating disk to allow rotation of the upper.

Compressibility: The change in volume of fluid when it is subjected to a unit change in pressure.

Counterbalance Valve (Holding Valve): A valve which regulates fluid flow by maintaining resistance in one direction, but allows free flow in the other direction.

Counterweight: Weight used to supplement the weight of the crane in providing stability for lifting loads.

Cracking Pressure: The pressure at which a pressure actuated valve begins to open to allow flow.

Crane Configuration: The relative position and arrangement of the parts or elements of the crane e.g. amount of counterweight, attachment position, etc.

Crane Control Module & Display: The computer in the operator's cab used for monitoring the engine and other controls. Also contains indicator lights for other controls.

Crane Rated Capacity: The maximum weight allowed to be lifted with the crane setup in a particular crane configuration.

Crane Rating Manual: A compilation of the necessary information needed to plan a safe lift with the crane. It includes instructions such as the allowable lifting capacity charts, Working Range Diagrams, Working Areas chart, etc.

Operator's Manual

Crane Set Up: The act or instance of preparing the crane for operation which entails the positioning of the crane and its elements. It concerns such details or items such as finding a suitable location to perform the lift, setting the outrigger position, leveling, cribbing, or blocking of the crane, etc.

Cylinder: A device which converts fluid power into mechanical force and motion. It usually consists of a moveable element such as a piston and piston rod, which operates within a cylindrical bore.

Delivery: The volume of fluid discharge by a pump in a given time, usually expressed in gallons per minute (gpm) or liters per minute (*L/min*).

Displacement: The quantity of fluid which can pass through a pump, motor, or cylinder in a single revolution or stroke.

Double Acting Cylinder: A cylinder in which fluid force can be applied in either direction.

Drum Lagging: See "Winch Drum".

Drum Rotation Indicator: A system that is used to monitor winch drum speed.

Filter: A device which functions to remove insoluble contaminants from a fluid by a porous media.

Flow Divider: A valve which divides a flow of oil into two streams.

Fly Base Section: Boom tip extension supported only at its base.

Force: Any cause which tends to produce or modify motion. In hydraulics, total force is expressed by the product of pressure (P) and the area of the surface (A) on which the pressure acts. (Formula: $F = P \times A$)

Frame: Structure on which either upper or carrier machinery is attached.

Friction: The property which tends to resist the relative motion of one surface in contact with another surface. It always exerts a "Drag" in the direction opposite of the motion, thus consumes power.

Full Flow: In a filter, the condition where all the fluid must pass through the filter element.

Full Load Speed: The speed at which an engine runs when it is delivering its full rated horsepower.

Function Limiters (Function Lockout, Hydraulic Cutoffs, Hydraulic Kickouts): Devices incorporated into the anti-two block system which will disable the crane function of winch up, telescope out, and/or boom down (as applicable) as a two block situation approaches.

Gradeability: The slope which a crane can climb expressed as a percentage.

Ground Pressure: Weight of crane divided by the area of the surface directly supporting the crane.

Guard Rails: Rails used to help provide safety (prevent falls) for personnel when required to be on the upper platforms of the crane during maintenance and/or adjustment procedures.

Head Machinery: An arrangement of sheaves on the end of an attachment used to reeve wire rope.

High Idle: Governed engine speed at full throttle and no load.

Hoist: Function of lifting and lowering loads.

Hoist Drum: See "Winch Drum".

Hoist Rope: The wire rope used to reeve the winch and the attachments for lifting loads.

Holding Valve: See "Counterbalance Valve".

Hook Ball: Ball with hook attached used in lifting service. It is used with one part of line only.

Hook Block: Block with hook attached used in lifting service. It may have a single sheave for double or triple line, or multiple sheaves for four or more parts of line.

Hydraulic Reservoir: The storage tank for hydraulic fluid.

Instability: A "tipping condition" in which the moments acting to overturn a crane exceed the moments acting to resist overturning.

Lifting Capacity: The rated load for any given load radius and boom angle under specified operating conditions.

Line Pull: The rope pull generated off a rope drum or lagging at a specified pitch diameter.

Line Speed: The rope velocity at a rope drum or lagging at a specified pitch diameter.

Load Radius: The horizontal distance from the centerline of rotation of the upper to the center of gravity of a suspended load.

Mat: Support, usually of timber or wire construction, for supporting the pontoons or tires on soft surfaces where their areas are not large enough to support the load without settling.

Motor (Hydraulic): A rotary motion device which changes hydraulic energy into mechanical energy, a rotary actuator.

Offset Fly: A hydraulic crane fly section that is capable of being pinned at different angles.

Oil Cooler: A heat exchanger used to remove heat from the hydraulic or transmission fluid.

Operator's Manual

Open Center Circuit: A circuit where the pump continuously circulates fluid through the control valves when they are in a neutral position.

Operational Aid: An accessory that provides information to facilitate operation of a crane or that takes control of particular crane functions without action of the operator when a limiting condition is sensed.

Operator's Cab (Upper Cab): A housing which covers the operator's station.

Outrigger: An extendable supporting device used to level the crane and increase stability.

Outrigger Beam: The part of the outrigger which extends horizontally and acts as the support for the outrigger jack.

Outrigger Jack: The hydraulic cylinder on the outrigger beam which extends vertically to raise and lower the crane.

Pick And Carry: The crane operation of lifting a load and traveling with it suspended.

Pilot Pressure: Auxiliary pressure used to actuate or control hydraulic components.

Pinion: Usually the small gear in a gear train which drives the other gears.

Pitch Diameter: Root diameter of drum, lagging, or sheave, plus the diameter of the rope.

Planetary: A set of gears used to either speed up or slow down the input vs the output to gain speed or power whichever is applicable.

Platform: A device (basket, work platform, bucket, cage, etc.) designed and fabricated with its intended use being to position personnel.

Pontoon: The support which attaches to the outrigger jack to increase the supporting area.

Poppet: A disc, ball, or cone shaped part of certain valves, which when closed against a seat prevents flow.

Port: The open end of a passage. May be within or at the surface of a hydraulic component housing or body.

Pressure: Force per unit of area usually expressed in pounds per square inch (psi) or Kilopascals (kPa).

Pressure Drop: The reduction in pressure between two points in a line or passage due to the energy lost in maintaining flow.

Pressure Reducing Valve: A valve which limits the maximum pressure at its outlet regardless of the inlet pressure.

Pump Disconnect: Engages and disengages the main hydraulic pump. Disengaging the pump aids in engine start-up by reducing cranking resistance.

Pump (Hydraulic): A device which converts mechanical force and motion into hydraulic fluid power.

Radius Of Load: The horizontal distance from the centerline of rotation of the crane to the center of gravity of the suspended load.

Rated Capacity Indicator (RCI): A device that automatically monitors radius, load weight, and load rating and warns the crane operator of an overload condition.

Rated Capacity Limiter (RCL): A device that automatically monitors radius, load weight, and load rating and prevents movements of the crane that would result in an overload condition.

Reeving: Passing of ropes over pulleys or sheaves.

Relief Valve: A pressure operated valve which bypasses pump delivery to the reservoir, limiting system pressure to a predetermined maximum value.

Reservoir: A container for storage of fluid in a fluid power system.

Restriction: A reduced cross-sectional area in a line which produces a pressure drop.

Rigging Switch (System Override Switch): A switch which can be used to override any or all of the function limiters (cutouts) which have been activated on the crane during crane rigging/set up.

Rope: Refers to wire rope unless otherwise specified. See "Wire Rope".

Rotating Joint: Component which transfers fluid between a stationary and a rotating member.

Schematic: A diagram or representation of a system showing everything in a simple way. No attempt is made to show the various devices in their actual relative positions. A schematic points out the operation of a circuit for troubleshooting purposes.

Seasonally: Four times per year.

Semiannually: Twice per year.

Service Brake: A foot operated brake which regulates the amount of force delivered to the brake chamber, which determines the braking force.

Shall: The word shall is to be understood as mandatory.

Should: The word should is to be understood as advisory.

Operator's Manual

Side Loading: A load applied at an angle to the vertical plane of the boom.

Single Acting Cylinder: A cylinder in which fluid power can only be used in one direction. Another force must be used to return the cylinder.

Spool: Term loosely applied to almost any moving cylindrically shaped part of a hydraulic component which moves to direct flow through the component.

Strainer: A filtering device for the removal of coarse solids from a fluid.

Stroke: The length of travel of a piston or spool.

Suction Line: The hydraulic line connecting the pump inlet port to the hydraulic reservoir.

Sump Tank: See "Hydraulic Reservoir".

Surge: A very sudden rise in hydraulic pressure in a circuit.

Swing: The rotation of the upper with the carrier remaining stationary.

Swing Brake: A foot operated brake which is used to stop the rotation of the upper over the carrier.

Swing Motor: Hydraulic device which uses a planetary to rotate the upper on the carrier.

Swing Park Brake: A self contained brake used for holding the upper, in any position, during normal, stationary crane operations.

T1 Section: The segment of the boom that is attached to the base and T2 sections.

T2 Section: The segment of the boom that is in the middle, that attaches to the T1 and T3 sections.

T3 Section: The segment of the boom which is attached to the T2 and T4 sections.

T4 Section: The outer most segment of the telescopic boom. It is attached to the T3 section and contains the head machinery of the attachment.

Tailswing: The swing radius from the centerline of rotation of the upper frame to the extreme rear of the counterweight.

Tip Section: See "T4 Section".

Torque: Turning or twisting force usually measured in foot-pounds (ft lb) or Newton meters (*Nm*).

Travel Swing Lock (2 Position Swing Lock): A mechanical lock that engages with the upper directly over either the front or the rear of the carrier only. Use of the travel swing lock is mandatory when traveling or transporting the crane and during pick and carry operations.

Turntable Bearing: A large bearing which attaches the upper to the carrier allowing the upper to rotate on the carrier.

Two Block: The situation when the crane's hook block or hook ball contacts the attachment's head machinery.

Two Block Warning System: A system of electromechanical devices used to warn the crane operator of impending two block condition.

Unloading Valve: A valve which by-passes flow to tank when a set pressure is maintained on its pilot port.

Upper: The portion of the crane located above the turntable bearing.

Upper Revolving Frame: The main structure of the upper section of the crane which serves as mounts for other components in the upper section.

Valve: A device for controlling flow rate, flow direction, or pressure of a fluid.

Viscosity: The resistance to flow. High viscosity indicates a high resistance, low viscosity, a low resistance.

Winch: Function of lifting and lowering loads.

Winch Drum: A rotating cylindrical spool with side flanges used to wrap the winch rope during the raising and lowering with the winch.

Winch Rope: The wire rope used to reeve the winch and the attachments for lifting loads.

Wire Rope: A flexible, multiwired member usually consisting of a core member around which a number of multiwired strands are helically wrapped.

Wiring Diagram: A diagram which includes all the devices in an electrical system and shows their functional relationships to each other. Such a diagram gives the necessary information for actual wiring or physically tracing circuits when troubleshooting is necessary.

Working Weight: Weight of crane with full radiator, half full fuel tank, and attachments installed.

360° Swing Lock: A positive mechanical lock against rotation of the upper over the carrier during normal, stationary crane operations.

Link-Belt Construction Equipment Company
2651 Palumbo Drive
P.O. Box 13600
Lexington, Kentucky 40583-3600
(606)-263-5200
http://www.linkbelt.com



ELECTRONIC DATA RECORDER REQUEST FORM

We, _____, hereby request
(Company Name)

Link-Belt Construction Equipment Company (LBCE) retrieve, interpret, and provide a summary of the electronic data recovered from the computer system installed by LBCE on model _____, with assigned serial number _____.

We request the following data be retrieved:
(Place check mark in box for information requested)

- Engine Performance Data (engine temperature, engine speeds, fluid temperature, etc.)
- Operational Mode (computer set-up)
- Boom Length
- Boom Angle
- Load Radius
- Counterweight Configuration
- Lifted Load(s)
- Number of Lifts
- Anti -Two Block (ATB) Status
- Status
- Other

Date(s) and Time Range(s) of data requested: _____

The time to reply to this inquiry will be three (3) weeks from the time the data is received by the LBCE Technical Product Support Department in Lexington Kentucky. The reply time may increase due to the amount of Data, and/or the Date and Time Range requested.

LBCE may assess a charge to provide the service of retrieve and interpretation of the data requested, plus travel time that may be involved by an LBCE representative to retrieve the data.

Requesting Company Representative

Date

